Optional add-on cassette

F10M option unit Instruction manual

Toshiba Schneider Inverter Corporation





NOTE

1. Make sure that this instruction manual is delivered to the end user of the the F10M option unit.
2. Read this manual before installing or operating the inverter unit, and store it in a safe place for reference.



Safety Precautions

On the inverter and in its instruction manual, important information is contained for preventing injuries to users and damages to assets and for proper use of the device. Read the instruction manual attached to the inverter along with this instruction manual for completely understanding the safety precautions and adhere to the contents of these manuals.

■ Handling in general

 Danger	
 Never Disassemble	<p>Never disassemble, modify or repair the inverter. Disassembling the inverter could cause electric shocks, fire or injuries. Request your TOSHIBA dealer for repairs.</p>
 Prohibited	<p>Do not remove connectors when the power is on. It could lead to electric shocks. ▼ Do not put or insert foreign objects such as waste cable, bars, or wires into the inverter. It could lead to electric shocks or fire. Do not splash water over the inverter. It could lead to electric shocks or fire.</p>
 Mandatory	<p>Wiring should be conducted after turning the inverter power off. Turn off the power immediately in case any abnormalities such as smokes, smells or abnormal noise are found. Neglect of these conditions could lead to fire. Ask your TOSHIBA dealer for repairs.</p>

■ Transportation and Installation

 Danger	
 Prohibited	<p>Do not install or operate the inverter if it is damaged or any part is missing from it. Operating the inverter in a defective condition could lead to electric shocks or fire. Ask your TOSHIBA dealer for repairs. Do not put any inflammable material near the inverter. It could catch fire if the inverter sparks because of a breakdown and the like. Do not install the inverter where it could be splashed with water and the like. It could lead to electric shocks or fire.</p>
 Mandatory	<p>Inverter must be used under environmental conditions prescribed in this instruction manual. Using the inverter under conditions not specified by the instruction manual could lead to breakdown.</p>

Warning



Prohibited

Do not install the inverter in any place subject to vibrations or it could fall.
Otherwise it can cause injury to people.

■ Wiring

Danger



Mandatory

▼ Be sure to perform the following preparatory work before proceeding to wiring.

- ① Turn the power off.
Wait 10 minutes or more after turning the power off and confirm that the charge lamp (on the inverter) is extinct.
- ② Using a circuit tester that has a D.C. voltage measuring capacity of more than 800V, check to see that the voltage remaining in the D.C. main circuit (between PC and PA) is below 45V.

Failure to do this preparation could lead to electric shocks.
Tighten the terminal board fixing screws at the specified torque.
Failure to do this could lead to fire.

■ About operation

Danger



Prohibited

Do not touch inverter terminals when they are energized even if the motor is halted.
Touching terminals while the power is energized could lead to electric shocks.

Do not wipe the body with a wet cloth.
It could lead to electric shocks.

Do not pull on the cable
It could cause damage or error.

■ About disposal of Inverter

Warning



Mandatory

Dispose of the inverter as an industrial waste.
Unless it is disposed of as an industrial waste, it will become risks for human injury.

Introduction

Thank you for purchasing the "F10M option unit" for industrial inverter TOSVERT VF-A7 and later series.

Read this manual carefully before using the unit.

Keep this manual near at hand of the operator who uses the "F10M option unit" for future reference in the maintenance and inspection.

For details of handling, it is requested to have the following instruction manuals.

- TOSLINE-F10M communication function manual (E6580773)

This manual describes the communication function and its use of TOSLINE-F10M.

- Serial communication function manual (E6580793)

This manual describes the details of transmission command.

< Type of F10M option unit >

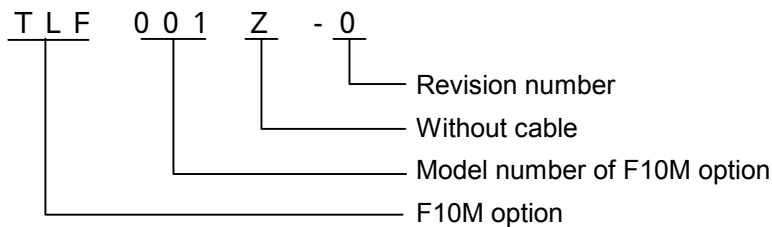

< Confirmation on accessories >

Following accessory parts are included in the F10M option unit.

Upon unpacking, confirm on the following items.

F10M option unit

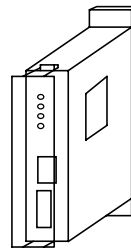

- (1) Instruction manual of F10M option unit (this manual) : one
(E6580772)



- (2) Board for connecting options



- (3) Terminal resistor (1/2W-120Ω)

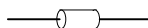

Contents

1. NAME AND FUNCTION OF EACH SECTION	5
1.1 Appearance	5
1.2 Name of each section (terminal)	6
2. CONNECTION TO THE INVERTER.....	7
2.1 Connection to the inverter	7
2.2 Wiring	9
3. FUNCTIONAL DESCRIPTION.....	10
3.1 F10M communication function	10
3.1.1 Connection of transmission cable.....	10
3.1.2 Setting of communication parameters.....	11
3.1.3 Communication parameters	12
3.2 Vector control with sensor	15
3.2.1 PG input setting	15
3.2.2 Connection of PG	16
3.2.3 Selection of encoder type	18
3.2.4 Vector control setting parameter	19
3.2.5 Monitoring method for feedback amount.....	21
3.2.6 Accuracy of speed control	21
4. EXTERNAL DIAGRAM.....	22
5. SPECIFICATION.....	23
6. WARRANTY	25

1. Name and function of each section

Following figure shows appearance and name of each section of the F10M option unit.

1.1 Appearance

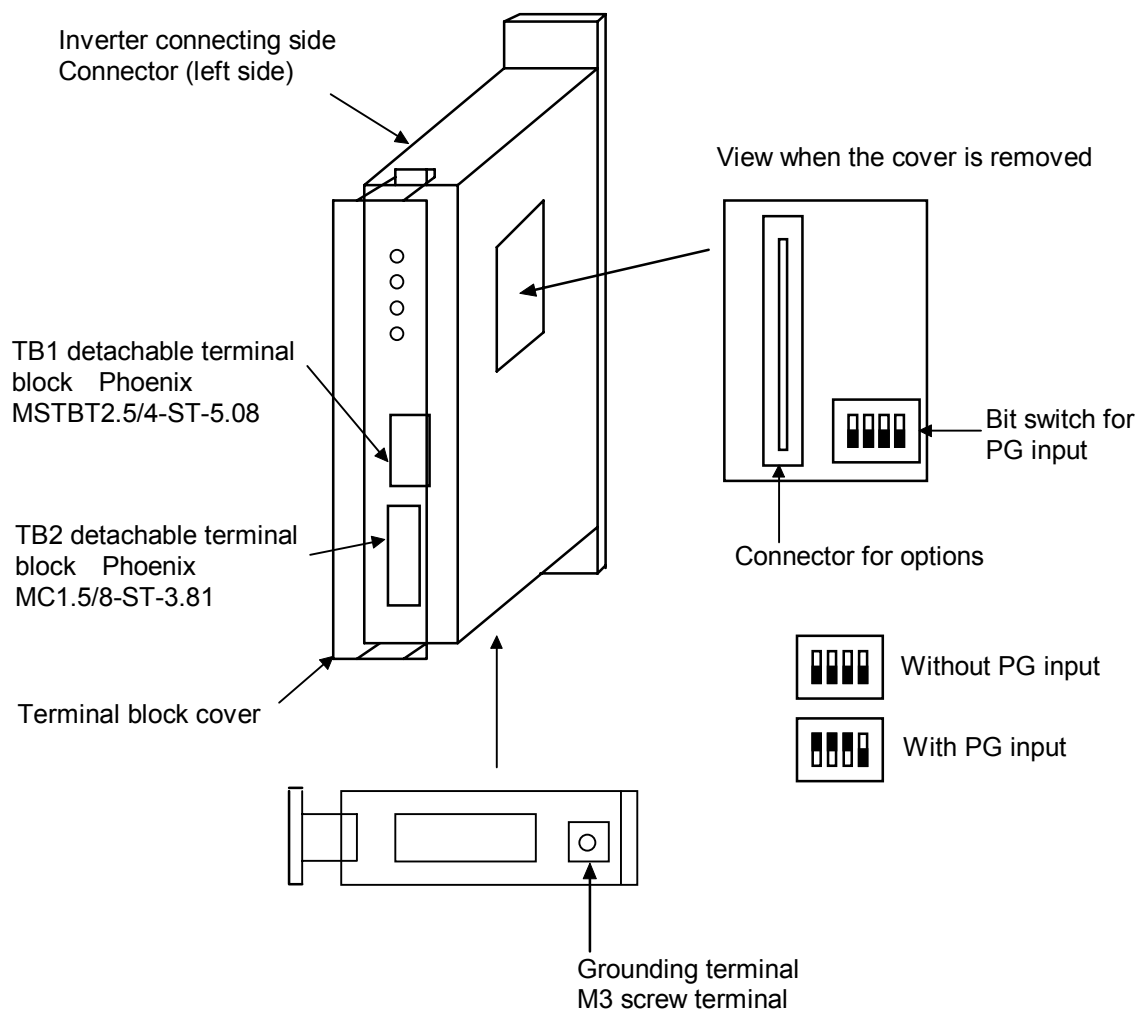

1.2 Name of each section (terminal)

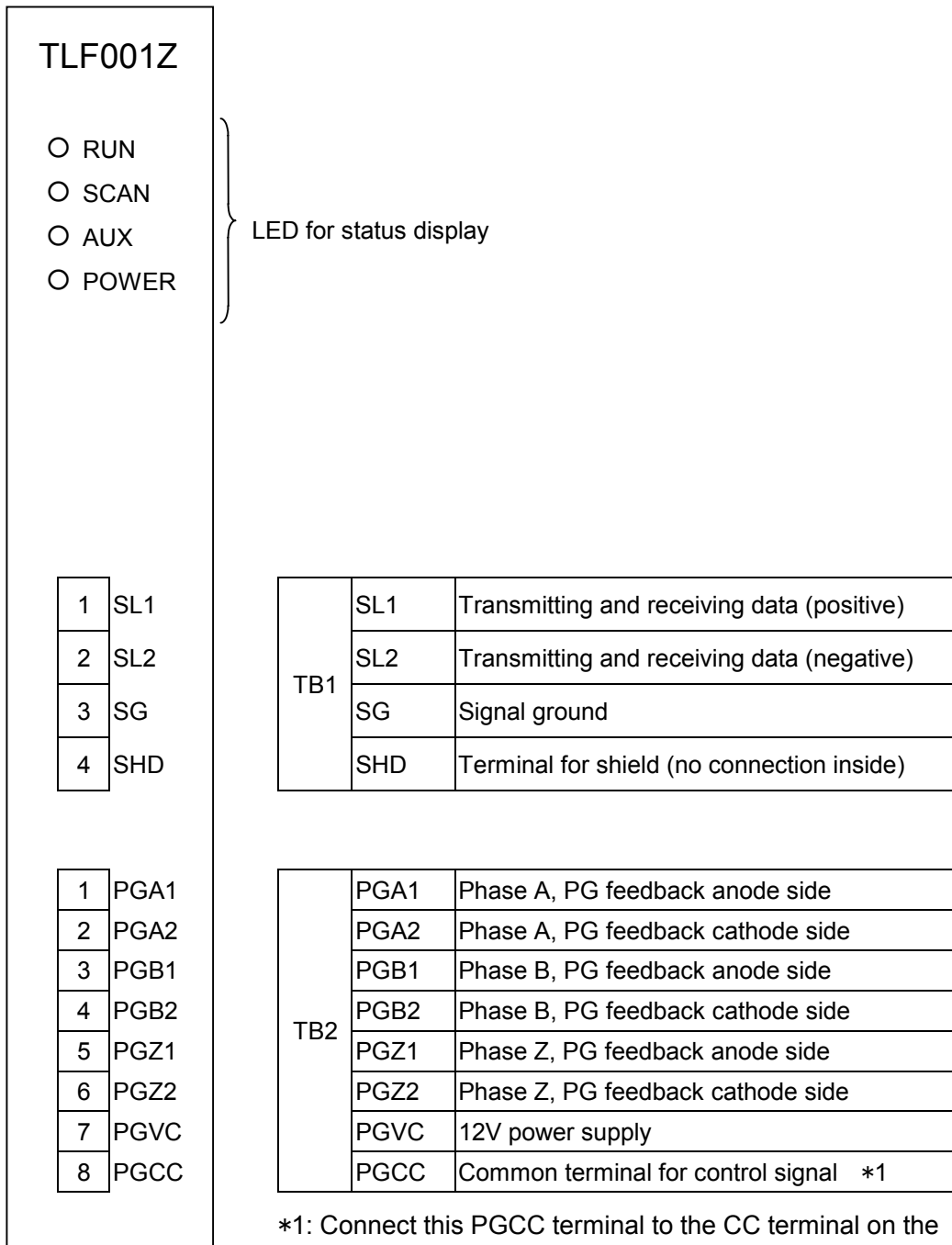

2. Connection to the inverter

Connect the F10M option unit to the inverter according to the procedures below.

2.1 Connection to the inverter

(1) Confirm that the all power to the inverter are turned off beforehand.

Note: Wait 10 minutes or more after turning the power off and confirm that the charge lamp on the inverter is unlit.

(2) Fixing the F10M option unit alone by using screws

<When the unit is installed alone>

Tighten M4x25 screws with M4 nuts to an attachment of optional add-on cassette (separately procured) to fix the unit as shown in the figure below.

<When the unit is installed with another option>

Read instructions of 'connection with options' on the following page for installation. Same procedures apply when three options are installed together.

(When plural options are installed, order of installation from the inverter side is not specified.)

(Note) Determine the initial setting of the bit switch for internal signal before connecting options.

Mount a board for option connection, then use M4x50 screws and M4 nuts to fix the options as shown below.

(When three units of option are installed, use M4x75 screws.)

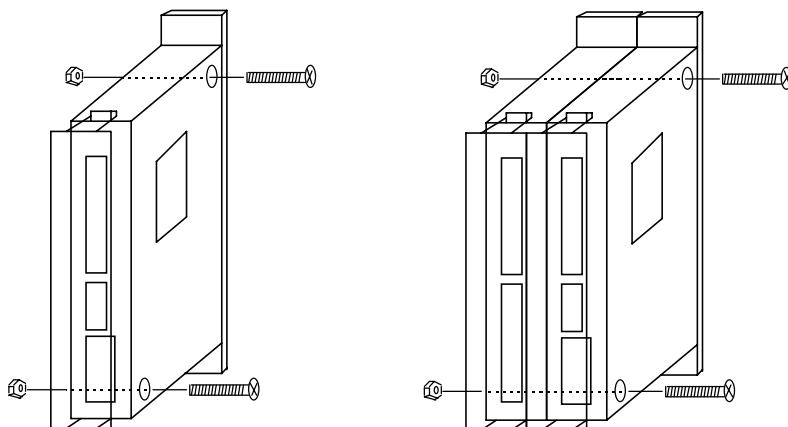

(3) Fixing the unit to the inverter

Method for fixing the unit to the inverter differs according to the type of inverter to which the unit is installed. Refer to the instruction manual of "Attachment of optional add-on cassette".

■ Connection with options

When two or more optional add-on cassettes are used, connect them with reference to the following diagram.

Mounting of relay board for connecting options

Following the diagram below mount the board which is attached to the F10M option unit onto the unit for connecting options.

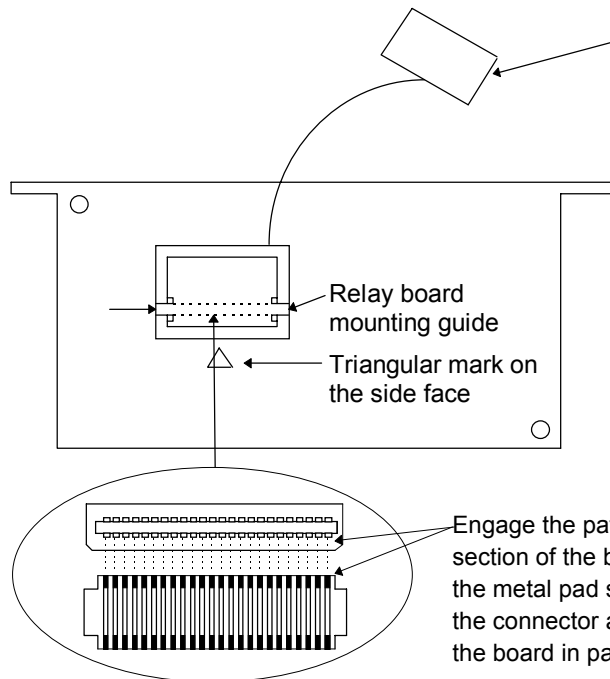

Insert a flat head screwdriver into the triangular section at the right side of the option unit and remove the small window cover.

Slide the relay board into the place according to the insertion guide.

(Note) Engage the patterned section of the board with the metal pad section of the connector and insert the board in parallel. When the insertion angle inclines, remove the board once and try again.

When the metallic parts of the relay board is touched with bare fingers, they oxidizes and the contacting failure occurs. Put on gloves for the work.

Connecting two options

Connect options with reference to the diagram below.

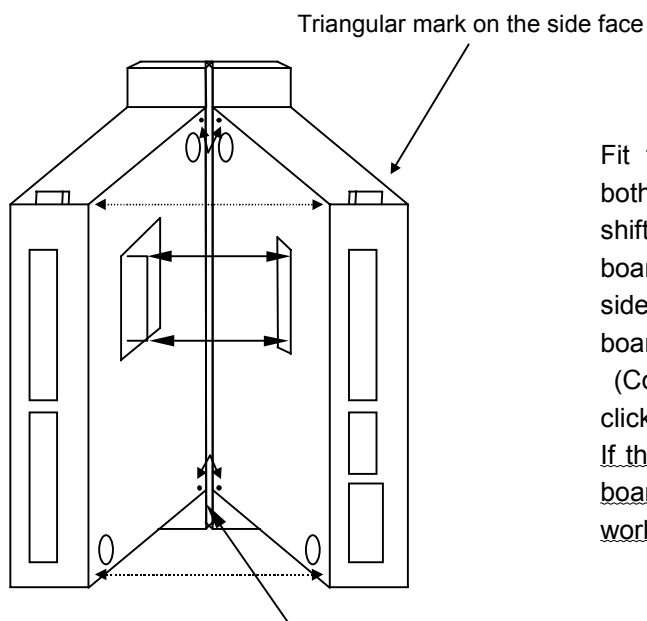

Fit two option's positioning guides on both units and connect two units not to shift the connecting position of the relay board. Hold a triangular section on the side of the unit and engage the relay boards securely.

(Connection is satisfactory when the click sound can be heard.)

If there is a gap between the units, two boards are misaligned. Carry out the work again from the beginning.

Option's positioning guide (two guides on top and bottom)

2.2 Wiring

When conduct wiring, follow the instructions below.

- Use shield wire for control signal line and ground the unit with shield wire.
- Applicable wire size for TB1 is 0.2 to 2.5mm².

For TB2, it is 0.2 to 1.5mm².

- Peel off the end of the wire by about 5mm (7mm for TB1).
- For connecting wires, use screwdriver that has a blade tip of 0.4mm thickness and 2.5mm width.

(For TB3, thickness and width should be 0.6mm and 3.5mm.)

- Tightening torque of the terminal block should be 0.22 to 0.25N·m .

(For TB1, it is 0.5 to 0.6N·m.)

- Never bind the signal line and main circuit connection wire together.

Separate the signal line and the main circuit connection wire by more than 200mm.

- Use 0.75mm² wire for the connection of PGCC terminal of the option side and CC terminal of the inverter.
- Use 0.75mm² wire for the connection of grounding terminal of the option side and that of the inverter.

■ < PG interface > [TB2 terminal]

Terminal name	Function	Specification	Internal circuit
PGA1	PG feedback input, Pulse row speed command input (Phase A input)	PG feedback <ul style="list-style-type: none"> • 15V complementary / open collector • 12V complementary / open collector 	
PGA2			
PGB1	PG feedback input Pulse row speed command input (Phase B input)	<ul style="list-style-type: none"> • Maximum input frequency 60kpps (2 phases) 120kpps (single phase) • Pulse duty 50 ± 10% 	
PGB2			
PGZ1	PG feedback input Pulse row speed command input (Phase Z input)		
PGZ2			
PGVC	PG power supply terminal	12VDC 160mA or less	
PGCC			

3. Functional description

In this section, functions added by the installation of this F10M option unit, on top of the standard inverter functions, are described.

3.1 F10M communication function

Through the communication network, drive and stop control and concentrated monitoring control of operation status can be carried out by the programmable controller and industrial computer.

3.1.1 Connection of transmission cable

- SL1, SL2, SG

Transmission path is constructed by the shielded twisted pair cables as shown in the figure below.

Be sure to connect SL1, SL2 and SG mutually to another station. Note that wrong connection will not bring the correct transmission.

- SHD

Connect a shield of twisted pair cable to the transmission terminal SHD of each station and set up a class 3 or equivalent grounding work in an arbitrary station.

- Terminal resistor

Set terminal resistors at both sides of the system for the sake of impedance matching. Connect terminal resistor ($120\ \Omega$ -1/2W) between the terminal block SL1 and SL2.

(As for the master station (MS), terminal resistor can be combined by connecting L1 and TERM.)

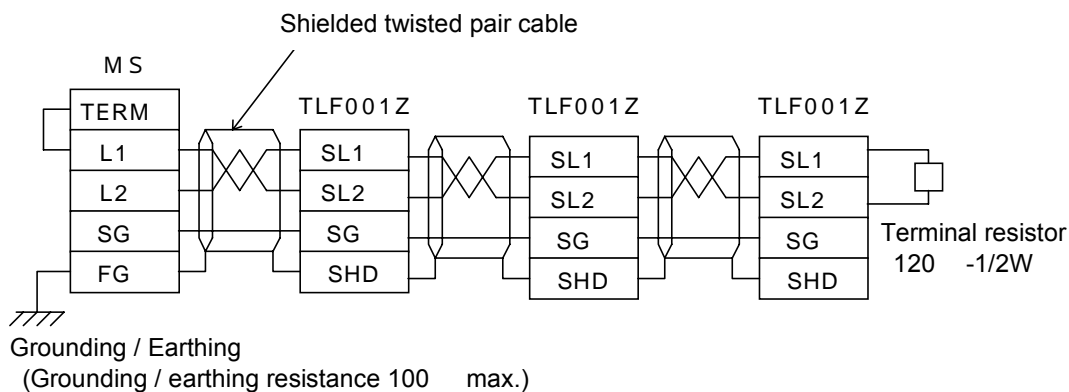

Connection of communication cable of TOSLINE F10M

Signal name	Name	Detail
SL1	Transmitting and receiving data	Positive line
SL2	Transmitting and receiving data	Negative line
SG	Signal ground	Ground of signal line

- Do not connect a grounding line of the shield and a power line earth of the inverter or so.
- Separate a transmission cable from the main circuit connection wire by more than 200mm.

3.1.2 Setting of communication parameters

To enable F10M communication, set following parameters to the inverter. The parameters will be validated by rebooting a power supply or changing a reset setting (*F899*) to *1*.

When interrupting a transmission to change the setting of command input, reboot a power supply if necessary, since the data which have been received before the interruption of transmission are stored in the inverter.

F00d	Operation command mode selection (Set this parameter to <i>4</i> to carry out run/stop with F10M communication.)
F00d	Speed setting mode selection (Set this parameter to <i>9</i> to execute frequency command with F10M communication.)
F802	Inverter number
F830	Data type selection
F831	Input reference setting 1
F832	Input reference setting 2
F833	Input reference setting 3
F834	Input reference setting 4
F835	Input reference setting 5
F836	Input reference setting 6
F841	Monitor output setting 1
F842	Monitor output setting 2
F843	Monitor output setting 3
F844	Monitor output setting 4
F845	Monitor output setting 5
F846	Monitor output setting 6
F850	Communication error selection
F851	Communication error detecting time
F899	Reset function (<i>1</i> to reset)

3.1.3 Communication parameters

■ F10M communication parameters

Parameter name	Title	Setting value	Details
Inverter number	<i>F802</i>	<i>0 to 255</i>	Sets inverter station address. (Note 1) <u>When using a message transmission, set the address of the master station to 0 and address of the inverter station to 1 or over.</u>
Data type selection	<i>F830</i>	<i>0, 1</i>	Selects type of transmitting and receiving data. <i>0</i> : VFA7 mode <i>1</i> : μ S250 mode
Input reference setting 1	<i>F831</i>	<i>0 to 16</i>	Sets scan transmission data to be received. <i>0</i> : Without setting <i>1</i> : Command <i>2</i> : Speed reference value <i>3</i> : Auxiliary speed reference value <i>4</i> : Torque limit value <i>5</i> : Positive torque limit value <i>6</i> : Negative torque limit value <i>7</i> : Torque command value <i>8</i> : Synchronized torque bias <i>9</i> : Tension torque bias <i>10</i> : Load sharing gain <i>11</i> : Drooping gain <i>12</i> : Speed loop proportional gain <i>13</i> : Speed loop accumulative gain <i>14</i> : Terminal output data <i>15</i> : Inertia moment ratio <i>16</i> : Expansion command
Input reference setting 2	<i>F832</i>		
Input reference setting 3	<i>F833</i>		
Input reference setting 4	<i>F834</i>		
Input reference setting 5	<i>F835</i>		
Input reference setting 6	<i>F836</i>		
Monitor output setting 1	<i>F841</i>	<i>0 to 16</i>	Sets scan transmission data to be sent. <i>0</i> : Without setting <i>1</i> : Status <i>2</i> : Operation frequency <i>3</i> : Speed feedback value (real time) <i>4</i> : Speed feedback value (1-second filter) <i>5</i> : Internal torque reference value <i>6</i> : Output amperage <i>7</i> : Exciting amperage <i>8</i> : Torque amperage <i>9</i> : Overload accumulative value <i>10</i> : Deleted torque of acceleration/deceleration torque <i>11</i> : Motor counter data <i>12</i> : Error code <i>13</i> : Input terminal data <i>14</i> : VI input <i>15</i> : RR input <i>16</i> : RX input
Monitor output setting 2	<i>F842</i>		
Monitor output setting 3	<i>F843</i>		
Monitor output setting 4	<i>F844</i>		
Monitor output setting 5	<i>F845</i>		
Monitor output setting 6	<i>F846</i>		

Parameter name	Title	Setting value	Details
Com. Error selection	<i>F850</i>	<i>0</i> to <i>4</i>	<p>Sets the inverter operation at time of communication error. The action of inverter will be different depending on the status (during operation or halt) of the inverter. (Note 2)</p> <p><i>0</i>: During halt Inverter stops after free run. During operation Inverter trips.</p> <p><i>1</i>: During halt Inverter stops after free run. During operation Inverter stops after free run.</p> <p><i>2</i>: Invalid (Setting is enabled with F10M option connected.)</p> <p><i>3</i>: During halt Inverter decelerates to stop. During operation Inverter decelerates to stop.</p> <p><i>4</i>: During halt Inverter continues to run. During operation Inverter continues to run.</p>
Com. Error detecting time	<i>F851</i>	<i>0</i> to <i>1000</i>	Sets the time until the communication error is detected. Setting is done by a unit of ms. (Note 3)
Reset function	<i>F899</i>	<i>0, 1</i>	<p>Resets the inverter station.</p> <p><i>0</i>: No action <i>1</i>: To reset the inverter station. After resetting, setting data returns to <i>0</i>.</p>

(Note 1) For setting the parameters, never duplicate the station address on the same communication line.

PLC rink relay register is automatically allocated according to the setting of the station address. As for the setting of station addresses, consider the allocation of rink relay register that is determined by the other station addresses and the number of words that have been set in the parameters *F831* to *F836*, and *F841* to *F846*.

The maximum setting value for station address is 255, however when 255 is set, only one word of scan data can be set. To set the scan data in its maximum value of 12 words, setting value of the station address should be: $255 - (12 - 1) = 244$.

(Note 2) Setting of “free-run stop” is valid when the “operation command mode selection” [*EN0d*] is selected to the optional add-on cassette.

Setting of “deceleration stop” is valid when the “operation command mode selection” [*EN0d*] is selected to the optional add-on cassette or when the “speed setting mode selection” [*FN0d*] is selected to the optional add-on cassette. At the same time the deceleration stop returns the command of run/stop and the speed reference value to 0. Except when the above command setting is selected, inverter cannot be stopped.

Furthermore when the “operation command mode selection” [*EN0d*] is set to other than the optional add-on cassette and when the “speed setting mode selection” [*FN0d*] is selected to the optional add-on cassette, in some cases inverter can not stop running because of the setting of the parameters (zero-speed operation setting). Torque control is valid when the “operation command mode selection” [*EN0d*] is set to the optional add-on cassette, but the inverter operation becomes “free-run stop” at that time.

Continuous operation depends on the status information that was before the communication error happens.

- Display of communication error will be [\underline{E}].
- Display of trip will be [$\underline{E} r r \underline{B}$].
- When interrupting a transmission to change the setting of command input, reboot a power supply if necessary, since the data which have been received before the interruption of transmission are stored in the inverter.
- Parameter setting of smaller communication number will be valid in case that the same setting values are allocated to the command input setting which are between 1 and 6, and also to the monitor output setting between 1 and 6.

(Note 3) The setting of communication error detection time is relating to the number of stations connected to the communication line. When changing the setting, fully consider the number of connected stations.

■ Other parameters

The following parameters reflect the transmitted data in the control of the inverter.

Parameter name	Title	Setting value	Details
Operation command mode selection	$\underline{C} \underline{r} \underline{0} \underline{d}$	4	Validates the command sent from the F10M option. Operation such as run/stop from the other station will be possible.
Speed setting mode selection	$\underline{F} \underline{r} \underline{0} \underline{d}$	9	Validates the speed reference value from the F10M option.
Torque command selection	$\underline{F} \underline{4} \underline{2} \underline{0}$	9	Validates the torque command value from the F10M option.
Selection of synchronized torque bias input	$\underline{F} \underline{4} \underline{2} \underline{2}$	5	Validates the synchronized torque bias from the F10M option.
Selection of tension torque bias input	$\underline{F} \underline{4} \underline{2} \underline{3}$	5	Validates the tension torque bias from the F10M option.
Load sharing gain input selection	$\underline{F} \underline{4} \underline{2} \underline{4}$	5	Validates the load sharing gain from the F10M option.
Power running torque limit 1 selection	$\underline{F} \underline{4} \underline{4} \underline{0}$	5	Validates power running torque limit from the F10M option.
Selection of regenerative torque limit 1	$\underline{F} \underline{4} \underline{4} \underline{2}$	5	Validates regenerative torque limit from the F10M option.

3.2 Vector control with sensor

Using the pulse-train feedback signal from the encoder installed on the motor shaft or load rotation shaft, vector control with sensor can be conducted.

Speed control operation :150% torque at 0 speed, speed control range 1:1000 (1000 ppr PG)
speed accuracy $\pm 0.02\%$ (50Hz base digital input)

Torque control operation :Torque control accuracy: $\pm 10\%$
(torque control range: -100% to 100%)

3.2.1 PG input setting

To carry out PG feedback with this F10M option, it is necessary to set the bit switches of the PG input selection. To select the PG input, open the small window cover on the right side of the option (use flat head screwdriver and the like) and set the position of the bit switches as shown in the figure below.

When the cover is removed.

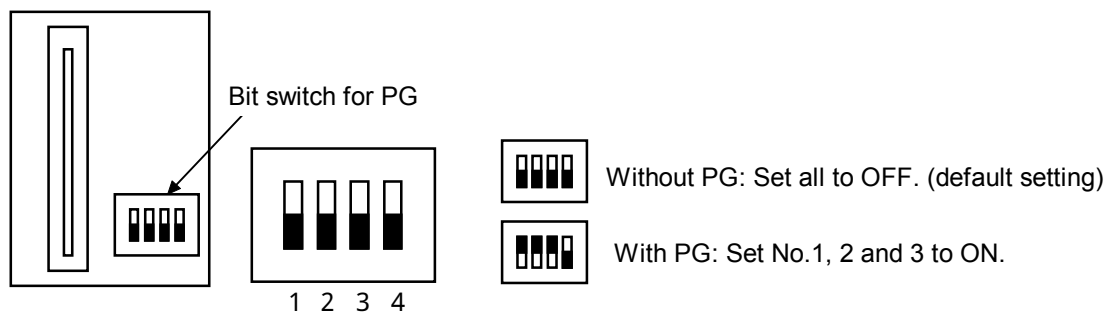

(Note) When using the PG feedback together with the vector option (VEC001Z), connect PG input to the vector option side and set all the bit switches of the PG input to OFF. If the setting of the bit switches is kept to "With PG" and the PG feedback is used together with the vector option, there is a possibility of malfunction in the PG feedback circuit and also the unit may be broken.

3.2.2 Connection of PG

As for the pulse input signals, PGA1 and PGA2 are connected for Phase A, PGB1 and PGB2 are connected for Phase B, and PGZ1 and PGZ2 are connected for Phase Z.

(The wiring for Phase Z is done only when using Z-marker is necessary.)

The polarity of the pulse input signals should be as follows:

+ side: PGA1, PGB1, PGZ1

- side: PGA2, PGB2, PGZ2

The signal which is fed back from the encoder should have the waveform of the figure below in terms of the direction of motor rotation. The encoder installation direction and signal wiring should be done accordingly.

Forward rotation or reverse rotation is judged from the feedback pulses of Phase A and Phase B (2-phase pulse that have 90 degrees of phase difference). Therefore, it should be noted that, when connections are wrong, there is possibility for abnormal rotation of the motor.

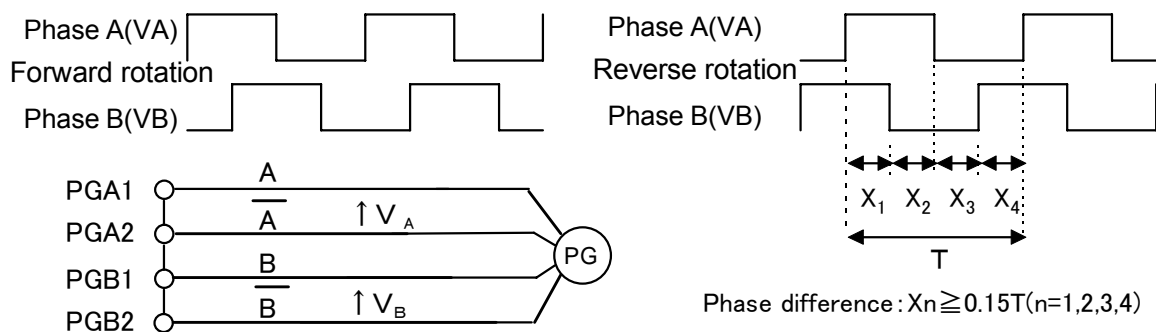

Judgement on normal and reverse rotations by the PG feedback of two phases (Phases A and B)

<When PG feedback signal is single phase>

1. For PG feedback signal, connect terminals PGA1 and PGA2.
 2. The judgement on forward rotation and reverse rotation is impossible.
- Only the speed control mode is applicable.

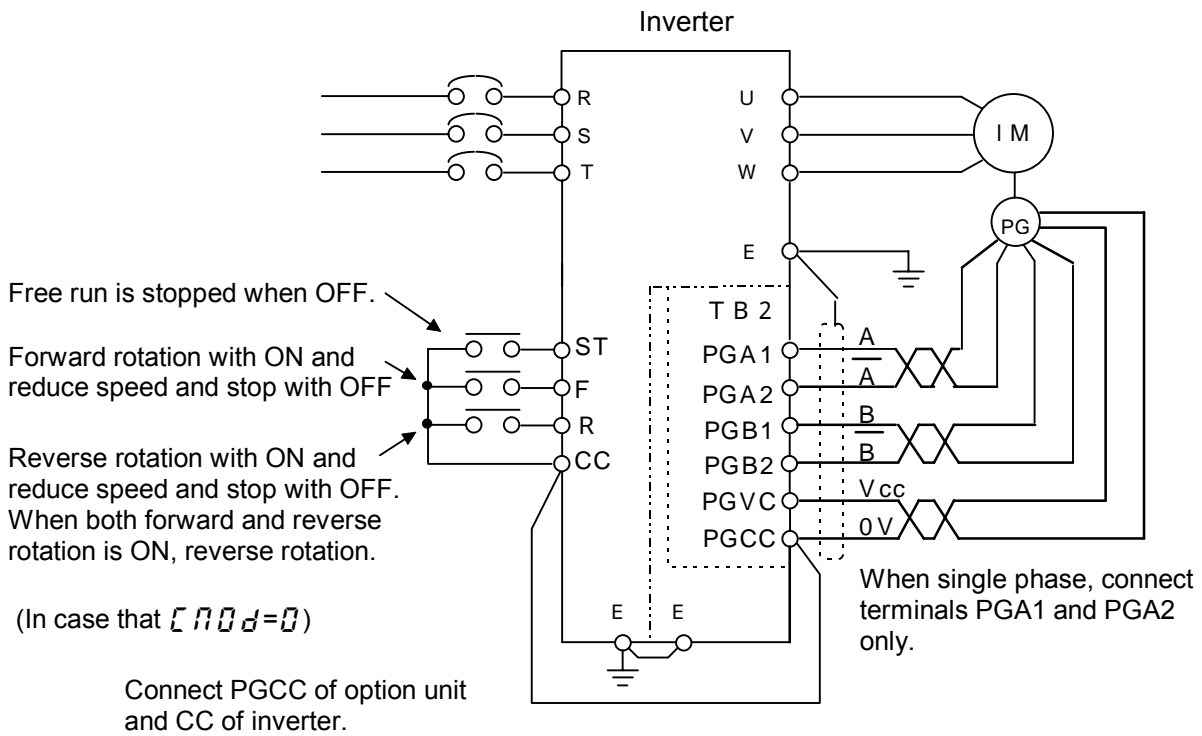

Example of complementary encoder connection

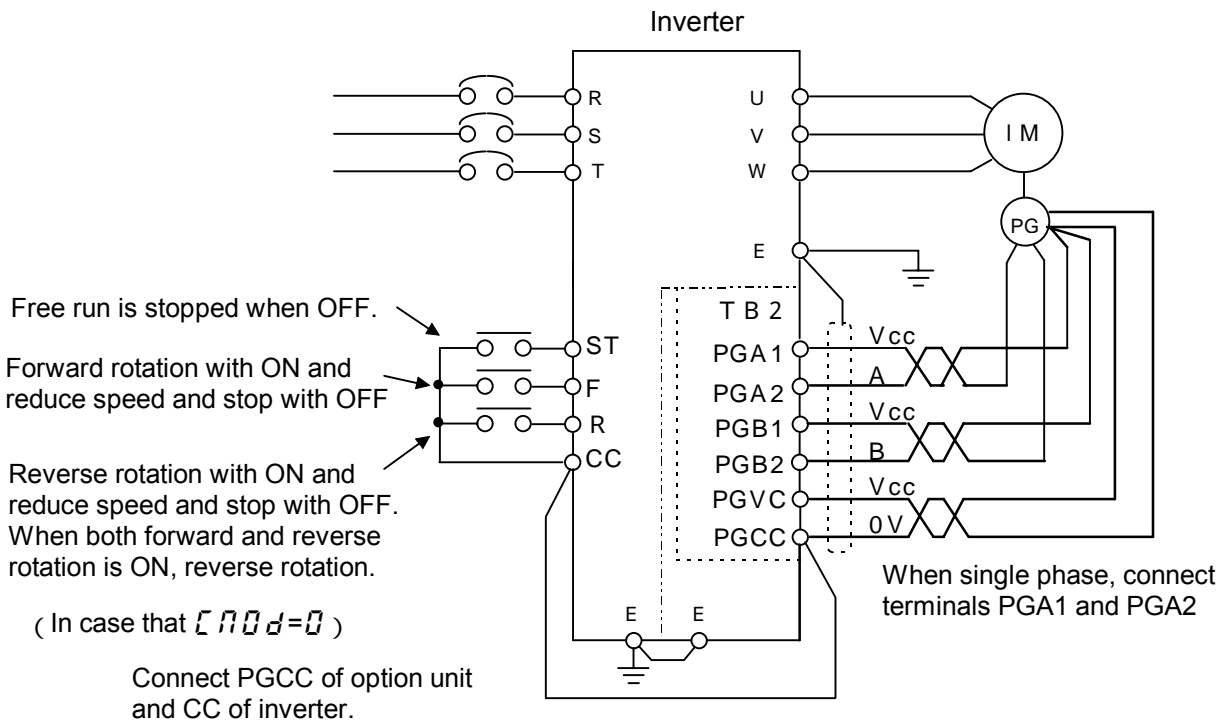

Example of open collector encoder connection

★ **Caution in case of using open collector encoder connection**

In case using pulse command oscillator and open collector encoder, the rise time of the voltage when the transistor is OFF tends to be longer than the fall time at the time when the transistor is ON. Therefore, if the maximum input frequency becomes higher, the pulse duty cannot maintain the 50±10% specification. Conduct derating on the maximum input frequency so that the pulse duty will be within the following specification range.

<Derating computation formulae of open collector's maximum input pulse frequency >

$$0.8 / (\text{Maximum input frequency} \times A) - \text{Voltage rise time} \geq 3 \times 10^{-6} \dots\dots\textcircled{1}$$

A : (single phase input: 2) (two-phase input: 4)

Voltage rise time = Encoder exclusive pulse rise time + R x C

Encoder exclusive pulse rise time (s) : Please inquire at the encoder manufacturer.

R (Ω) (Input resistance) : internal resistance 1000(Ω) + external resistance value
(In case there is external resistance)

C(F) (Cable static capacity) : Please inquire at the cable manufacturer.

<Example>

Encoder : LBJ-005-500 (SUMTAK), 2-phase input

Encoder pulse rise time : 0.35×10^{-6} (s)

Cable : ROVV-SB-0.2-5P-10m (Furukawa Electric Co., Ltd)

Static capacity : 120×10^{-12} (F/m) x 10 (m)

From Formulae $\textcircled{1}$

$$0.8 / (\text{Maximum input frequency} \times A) - \text{Voltage rise time} \geq 3 \times 10^{-6}$$

$$\begin{aligned} \text{Voltage rise time} &= (0.35 \times 10^{-6}) + 1000 \times (120 \times 10^{-12} \times 10) \\ &= 1.55 \times 10^{-6} \end{aligned}$$

$$[\text{Maximum input frequency}] \leq 87912 \text{ (Pulse/s) [Single phase input]}$$

$$\leq 43956 \text{ (Pulse/s) [Two-phase input]}$$

3.2.3 Selection of encoder type

The encoder type should be selected, following the table below.

Encoder Type	Characteristics	Maximum Wiring Length
Complementary	Rated voltage output with emitter/follower combination. High anti-noise characteristics. High-speed response. Long-distance transmission capability. Need to pay attention to waveform irregularity.	100m
Open Collector	The collector of the transistor is output directly. Low anti-noise characteristics. Low-cost. Need to pay attention to waveform irregularity and distortion.	10m

3.2.4 Vector control setting parameter

During operation with vector control with sensor, it is necessary to set the following parameters shown in the table below.

<Basic parameters>

Title	Function Name	Parameter Setting	Setting at Shipment
Pt	Motor control mode selection	0: Constant torque 1: Variable torque mode 2: Automatic torque boost 3: Sensorless vector control (speed) 4: Automatic torque boost + automatic energy-saving 5: Sensorless vector control (speed) + automatic energy-saving 6: V/F 5-points setting 7: Sensorless vector control (speed/torque switching) 8: PG feedback vector control (speed/torque switching) 9: PG feedback vector control (speed/position switching)	0 Standard : speed control

When conducting vector control with sensor (speed/torque control) with this F10M option unit is added, $Pt = 8$ should be set.

For torque control operation, it is necessary to allocate control switching (torque/position) to one of the terminal function selection $F110$ to $F118$ (input terminal selection 1 to 8) ($CNOd = 0$) or to set operation switching by communication system ($CNOd = 2$ to 4) in addition to the above parameters.

For details of adjustment methods by the speed control command and torque control command, refer to the inverter's instruction manual.

Extended Parameter

Title	Function Name	Parameter Setting	Setting at Shipment
$F367$	Number of PG input pulse	1~9999	500
$F368$	Selection of number of PG input phases	1: Single phase input 2: 2-phase input	2
$F374$	Current control proportional gain	0.1~1000	Depends on type.
$F375$	Current control integral gain	0.1~1000	Depends on type.
$F376$	Speed loop proportional gain	3.2~3270	Depends on type.
$F377$	Speed loop integral gain	0.8~125.0(rad/sec)	Depends on type.
$F400$	Auto tuning	0: No auto tuning (internal table) 1: Motor constant initialization 2: Auto tuning (0 after execution)	0
$F401$	Slip frequency gain	0.00~2.55	0.60
$F402$	Motor constant 1(primary resistance)	0.01~100000mΩ	Depends on type.
$F403$	Motor constant 2(secondary resistance)	0.01~100000mΩ	Depends on type.
$F404$	Motor constant 3(exciting inductance)	0.1~6500mH	Depends on type.
$F405$	Motor constant 4(load inertia moment)	0.1~100.0	1.0
$F410$	Motor constant 5(leak inductance)	0.01~650.0mH	Depends on type.
$F411$	Number of poles of motor	2, 4, 6, 8, 10, 12, 14, 16	4
$F412$	Rated capacity of motor	0.1~280kW	Depends on type.
$F413$	Motor type	0: TOSHIBA Standard Motor 1 1: TOSHIBA VF motor 2: TOSHIBA V3 motor 3: TOSHIBA Standard motor 2 4: Other	0

The motor constant parameter ($F400$ to $F413$) requires setting according to the motor used.

For details, refer to the inverter manual.

(1) Number of PG input pulse (F 3 5 7) is the number of encoder output pulses per one motor rotation.

(2) For selection of number of PG input phases (F 3 5 8), set as follows:

If the encoder pulse is single-phase: 1

If the encoder pulse is two-phase: 2 (Phase A and Phase B or Phase A and Pulse B + Z origin signal)

When the settings for the above (1) and (2) are wrong, the motor rotation will become abnormal.

(3) Adjustment methods for current control proportional gain (F 3 7 4) and current control integral gain (F 3 7 5):

These need to be adjusted when it is necessary to fine-tune torque responses. (Normally, standard setting should be used.) For details of adjustment, refer to the inverter manual.

(4) Adjustment method for speed loop proportional gain (F 3 7 6) and speed loop integral gain (F 3 7 7)

The principle of the feedback control is a proportional action. This action produces output in proportion to the speed deviation. It is a simple mechanism but it takes some time until the speed becomes stable. Proportional action merely produces some offset values. (The speed deviation will not be eliminated completely with reference to the command frequency.)

In order to eliminate the offset, integration action is effective where the output is calculated by the accumulation of past deviations (from start of operation until now) and added to the proportional action.

<Speed loop ratio gain>

Adjustments are necessary in accordance with the inverter capacity and load inertia ratio.

Set the ratio referring the formulae below as the rule of thumb.

Speed loop ratio gain = $(50 + A \times P_w) \times J^{0.12}$

A : Coefficient by number of motor poles (2 poles: 1.8 4 poles: 2.0 6 poles: 2.2)

P_w : Inverter capacity (Example: in case of 3.7kW unit $P_w=3.7$)

J : Load inertia/TOSHIBA standard motor inertia
(Example: In case of inertia ratio being 4, J = 4)

<Speed loop integration gain>

Standard setting at shipment should be used usually.

In case fine-tuning of speed response is necessary, adjust parameters by the following procedure.

Measurement device needed for adjustment: Waveform measurement device such as an oscilloscope.

① Connect the probe of the measurement device to the analog monitor output terminal of the inverter (between the FM terminal and CC terminal).

Set FM terminal output to Speed Feedback (real-time value). (Refer to 3.2.5 Monitoring method for feedback amount.)

② Set the acceleration time to minimum, so that there will be no over-current stall. (C blinking)

③ Set the operation command mode selection (C n o d) and speed setting mode selection (F n o d) to panel input effective. (C n o d = "1", F n o d = "5")

④ Set the speed setting to about 10Hz and press (RUN) key to measure the speed response waveform at operation start. Press (STOP) key to stop operation.

⑤ In order to improve the speed response, gradually make the speed ratio gain greater (F 3 7 6) and repeat above④ operation and adjust to immediately prior to motor oscillation.

⑥ Adjust the speed loop integral gain (F 3 7 7). Repeat the operation in④ above and adjust the parameter so that the speed deviation is contained at expected response time.

This concludes the speed loop gain setting.

3.2.5 Monitoring method for feedback amount

Motor rotation speed can be monitored.

The motor is equipped with status monitor which is displayed on the panel and analog monitor which used analog output terminals (FM, AM terminals)

Set items① and② for motor speed monitoring.

① Speed feedback (real-time value) (Unit: Hz/free unit)

The real-time display of motor speed can be made (Monitor display setting: 5).

② Speed feedback (one-second filter) (Unit: Hz/free unit)

The filtered motor speed (feedback value) is displayed. (Monitor display setting: 7).

The monitoring for the above① and② is possible also in cases except for $P \neq 2$ (PG feedback vector control operation). For example, the monitoring can be used for confirmation of the initial PG feedback amount in open loop (V/F operation and the like).

<Setting method for status monitoring>

In order to monitor motor rotation speed in condition monitoring, it is necessary to change the setting for extended parameters (F711 to F714).

Refer to <Monitoring Operating Condition> section of the inverter manual.

<Setting method for analog monitoring>

In order to monitor motor rotation speed by the analog output terminal, it is necessary to change the setting for basic parameter (F751, F7) and extended parameter (F670, F671).

Refer to (Meter Setting and Calibration) section of the inverter manual.

3.2.6 Accuracy of speed control

The accuracy of speed control with the PG feedback can be obtained by the following formulae.

Accuracy of speed control = Command frequency accuracy + feedback detection accuracy

$$\text{Command frequency accuracy} = \pm \frac{0.01(\text{Hz})}{F_c(\text{Hz})} \times 100 \times \frac{1}{2} [\%]$$

(using digital command)

$$\text{Feedback detection accuracy} = \pm \frac{1}{F_c/(P/2) \times PG \times PH \times 0.04} \times 100 \times \frac{1}{2} [\%]$$

F_c : Inverter output frequency

P : Number of motor poles

PG : Number of PG pulses/rotation

PH : Single Phase = 1, Two-Phase = 4

0.04 : Response speed of 40ms

4. External diagram

Do not forget to reserve the space for the options at time of installation.

■ External diagram of add-on options / External dimension diagram of unit with option installed

(unit: mm)

Dimension of optional unit

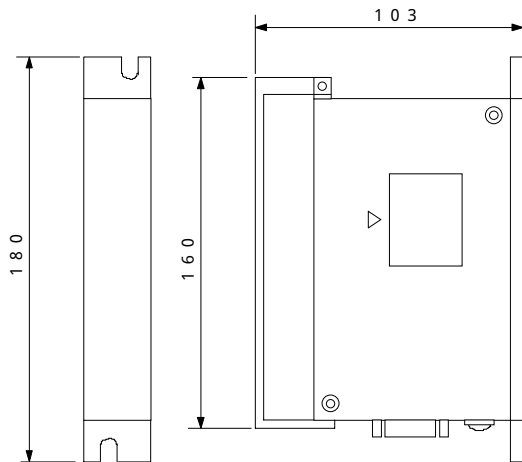

When installing optional add-on cassette, secure sufficient space on the right side and front of inverter body.

Space necessary for installing the options is different according to the type of inverter. Refer to the instruction manual of inverter.

Figure below shows the installation dimensions for VFA7 inverter.

External dimensions for installing the unit (1)

< 30kW or smaller unit >

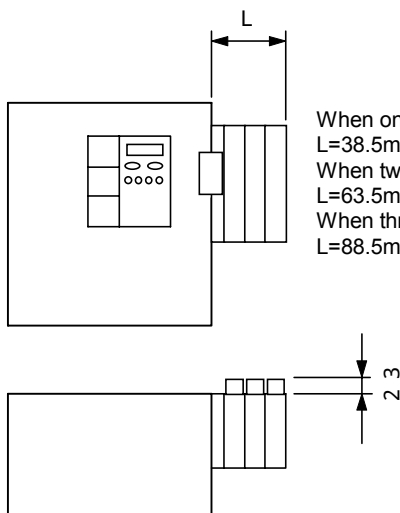

When one cassette is installed,
L=38.5mm
When two cassettes are installed,
L=63.5mm
When three cassettes are installed,
L=88.5mm

External dimensions for installing the unit (2)

< 37kW or larger unit >

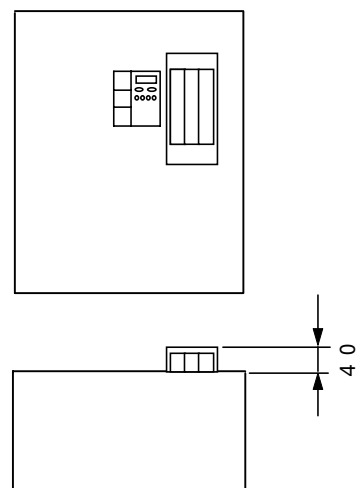

5. Specification

<Environment Specification>

Item	Specification
Use Environment	Indoor, less than 1,000 m from the sea level. No direct sunlight, corrosive or explosive gas, steam, cutting dusts or dusts, grinding solution, and grinding oil.
Ambient Temperature	-10 to +50
Storage Temperature	-25 to +65
Relative Humidity	20 to 90 % (No condensation)
Vibration	5.9m/s ² or less

< PG feedback specification >

Full-vector operation with sensor	Speed control operation: [150% torque at 0 speed, speed control range: 1:1000(1000 ppr PG), speed accuracy $\pm 0.02\%$ (50 Hz base digital input)] Torque control operation: [torque control accuracy $\pm 10\%$, (torque control range: -100 to 100%)]
PG Method	Complementary, Open-collector
PG Wiring Length	100m (Max.)(Complementary)
PG Power Supply	12V -160mA
Max. Pulse Input Frequency	120kHz or less (single-phase), 60kHz or less (two-phase) * (In case of 2-phase open collector method, derating need to be considered) Pulse duty: 50 \pm 10%
Pulse input voltage	12V dc to 15V dc
Recommended Encoder	Manufacturer: SUMTAK Co., Ltd. Type: LBJ series Supply Voltage: 12V Output Method: complementary output
Encoder Wiring (Recommended Cable)	Type of Wire: Twisted Pair Shield Cable Conductor Resistance: Conductor Resistance (Ω/m) x cable length (m) x 2 x power consumption (A) <V _D (V) V _D (V): 1.0(V) [PG for 12V] Applicable Wire: 0.2-1.5mm ² (Power Line) In case of 0.2mm ² cable: maximum of 30m [Complementary PG] maximum of 10m [Open collector PG] KURAMO Electric: KVC-36SB , Furukawa Electric: ROVV-SB

<Specifications of transmission>

Use TOSLINE-F10M as a master station. For the connection with master station TOSLINE-F10 (standard type), refer to the instruction manual of "TOSLINE-F10M Communication function" (E6580773).

■ Network (TOSLINE-F10M) specification

Item	Specification:TOSLINE-F10M (when repeater is used)
Number of transmission words	Max. 256W
Transmission distance	Max. 2Km
Valid transmission speed	100ms/256W
Number of connected station	Max. 256 stations (when 1W/1 unit)

■ Inverter side TOSLINE-F10M specification

Item	Specification
Structure of transmission path	Party-line type
Signal transmission method	Start-stop synchronization
Access method	Poling & selecting method
Coding method	Base band, NRZ, Positive logic
Checking method	CRC check
Communication standard	Complies to EIA RS485.
Data signal speed	750kbps (high speed mode)
Number of transmission words	Max. 12W per one inverter (6W input, 6W output)
Processing time (note)	Max. 10ms (when only for scan transmission)
Communication service	Scan transmission, message transmission
Applicable model	Following functions of master station are possible. <ul style="list-style-type: none"> • Function for selecting scan/message transmission • Intermittent entering/secession function • Function for selecting input data status at time of error • MS monitoring function

(Note) Processing time means a cycle that the inverter gets access to the data and not including a transmission time, etc.

■ Transmission cable specification

Item	Specification		
Transmission cable	Shielded twisted pair cable		
Connecting method	Connect SL1(L1), SL2(L2) and SG respectively. Use twisted pair cable for SL1 and SL2. (Note) Connect terminal resistors (both ends) to the end of the transmission path.		
Transmission cable length	Cable type	Cable length	Recommended manufacturer
	CPEV-CU 1.2mm ϕ (single core)	500m or shorter	
	KMPEV-SB 0.75mm ² (stranded wire)	400m or shorter	
	KMPEV-SB 0.5mm ² (stranded wire)	200m or shorter	Showa Electric Wire & Cable Co., Ltd.

Use same type of cable in one system.

6. Warranty

TOSHIBA provides warranty with the product under the following conditions.

1. If and when a trouble occurs on the option unit properly installed and handled within one year of delivery, and if the trouble is clearly attributable to defects inherent in our design and manufacture, the product will be repaired free of charge.
2. The warranty covers only the delivered option unit.
3. Even in the term of the warranty, repair/adjustment service will be charged for the following cases.
 - 1) Fault or damage resulting from misuse, unauthorized modification or repair.
 - 2) Fault or damage resulting from falling down of the product or traffic accident during transportation.
 - 3) Fault or damage originating from fire, salt water/salty breezes, some kind of gas, earthquake, storm or flood, lightning, abnormal supply voltage, other natural disasters.
 - 4) When the unit was damaged because of the application other than specified to the F10M option unit.
4. If there is another special warranty contracted for this option unit, the special warranty has priority over this warranty.