

■ EMC Guidance

- Never bundle the encoder cables and the power cables together. Failure to comply will result in encoder interference.
- The motor housing must be connected to the grounding terminal of the AC drive. Meanwhile, connect the grounding cable of the motor to the motor housing reliably.
- An STP cable is suggested. For differential encoders, perform cable connection based on the differential pairs properly and connect the shield to the grounding terminal of the AC drive.
- For large equipment application where the AC drive is far away from the motor and the motor cable is longer than 10 m, the **grounding effect is not good due to the influence of cable inductance. In this case, the encoder shield need not be connect the grounding terminal of the AC drive.**

■ Connecting Encoder to the PG Card

The following figure shows the circuit diagram of connecting the encoder to the MD38PG5/MD38PG5D.

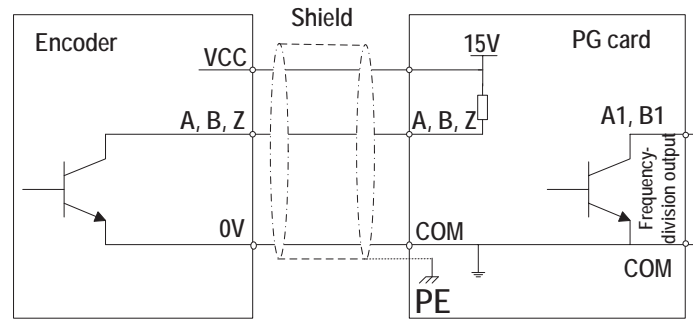

The following figure shows the circuit diagram of connecting the encoder to the MD38PG1/MD38PG6/MD38PG6D.

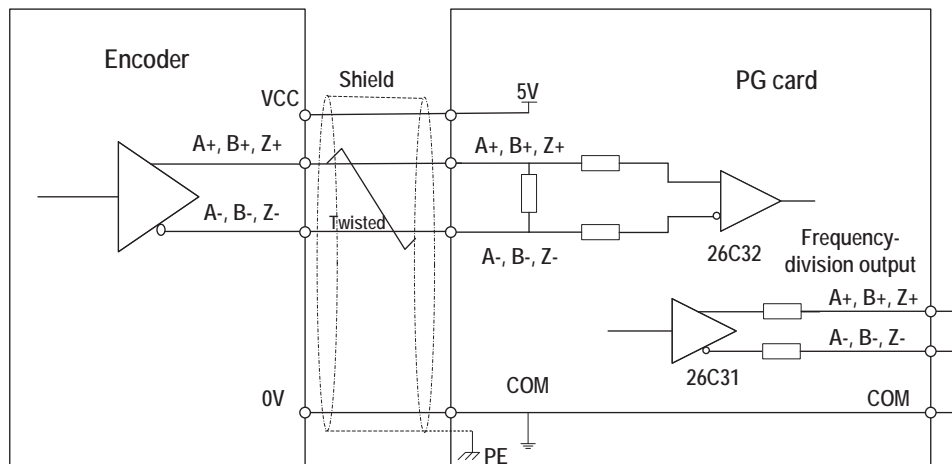

The following figure shows the circuit diagram of connecting the encoder to the MD38PG4.

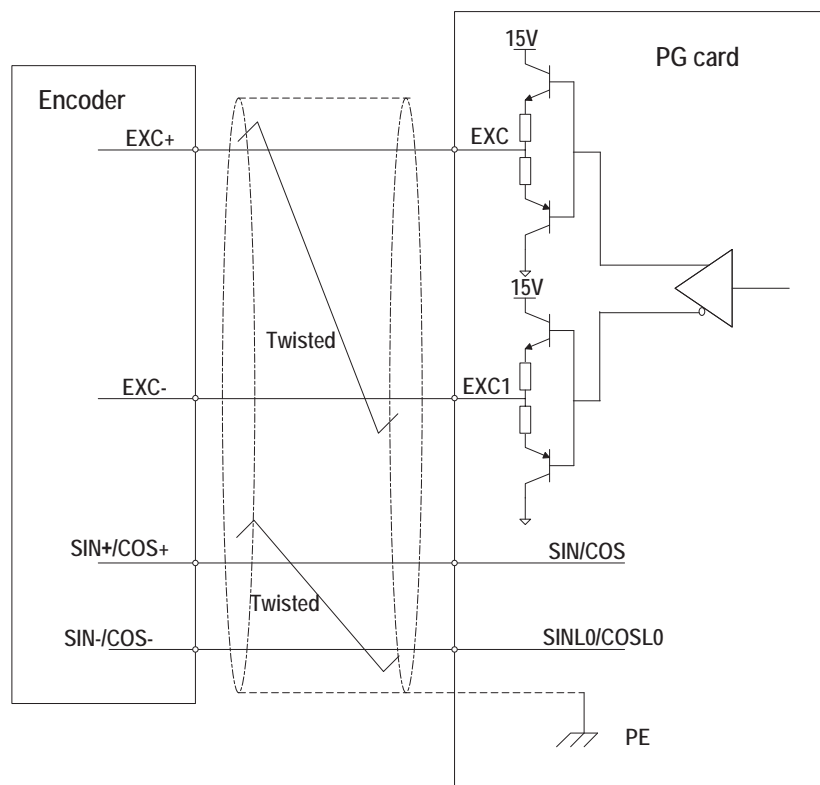

■ Description of Use of MD38PG4

1. The MD38PG4 card has two red LED indicators marked as D5 and D6. They are used to indicate the MD38PG4 state. The indicators are described in the following table.

D5	D6	MD38PG4 State	Solution
OFF	OFF	Normal	-
ON/Flashing	OFF	Phase-lock loop unlocked	Phase lag of the resolver is very large.
OFF	ON/Flashing	The SIN/COS signal exceeds the limit.	It is caused by interference. Ground the motor well and connect the ground point of the PG card to the PE terminals of the AC drive.
ON/Flashing	ON/Flashing	The SIN/COS signal is too small.	Generally, it is because the DB9 connector is not connected, connected wrongly or the wire breaks. If these caused are removed, check whether the resolver matches the MD38PG4 card.

2. Selection of the resolver must satisfy the parameter setting requirement of the MD38PG4. Especially the excited input DC resistance must be larger than 17Ω (can be measured by multimeter). Otherwise, the MD38PG4 cannot work normally.
3. It is suggested to select a resolver with a maximum of four pole-pairs. Otherwise, the MD38PG4 will be in overloaded state.
4. On the condition that the software parameters of the AC drive are set correctly, the speed or position feedback of the MD38PG4 is instable, it indicates that the MD38PG4 gets electromagnetic interference. In this cause, connect the shield of the signal lines of the encoder to the PE terminal of the AC drive.

■ Description of Shield Grounding of the MD38PG4

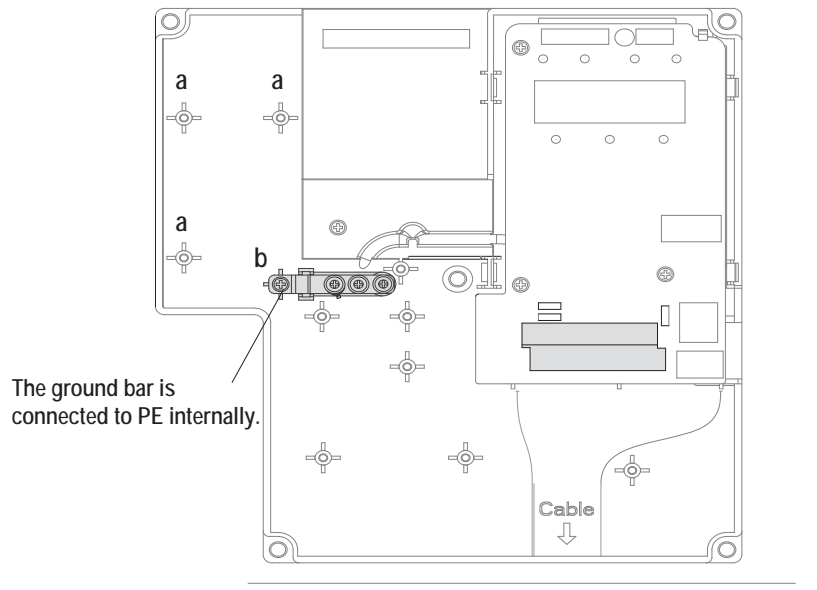

As shown in the preceding figure, grounding has been completed in position b. After installation of the PG card is done, the PE terminal of the PG card is connected automatically.

When connecting the signal lines of the encoder, connect the shield of the signal lines to the PE terminals of the PG card to complete the shield grounding.

To install the PG card, remove the screw in position b and align the mounting holes of the PG card to the four fixing holes and fix the PG card with the prepared M3 x 8 screws.

MD38PG6/ MD38PG6D Terminals		
DB9 Terminal No.	Mark	Description
1	A+	Encoder output signal A positive
2	A-	Encoder output signal A negative
3	B+	Encoder output signal B positive
4	B-	Encoder output signal B negative
5	Z+	Encoder output signal Z positive
6	Null	-
7	+5V	Encoder 5V power supply positive
8	COM	Encoder power supply negative
9	Z-	Encoder output signal Z negative
User interfaces J7, J8: MD38PG6 has the 1:1 frequency dividing output. MD38PG6D has the selectable frequency dividing output (1:4 by default).	A+	Frequency dividing output signal A positive
	A-	Frequency dividing output signal A negative
	B+	Frequency dividing output signal B positive
	B-	Frequency dividing output signal B negative
	Z+	Frequency dividing output signal Z positive
	Z-	Frequency dividing output signal Z negative
	COM	Signal power ground
PE	Shield connecting point	

■ Description of Frequency Dividing of MD38PG5D/MD38PG6D



The frequency dividing coefficient is determined by the DIP switch K1 on the PG card. The DIP switch has a total of five digits.

The coefficient is obtained by multiplying the binary number expressed by the DIP switch by 2. Bit 1 is the lowest bit, and bit 5 is the highest bit. If the bit is set to ON, it is effective. Minimum 1:4 and maximum 1:62 frequency dividing can be implemented.

The correspondence of the binary number expressed by the DIP switch and the frequency dividing coefficient is as listed in the following table.

	Binary Number	Frequency Dividing Coefficient
0	00000	No output
1	00001	No output
2	00010	22
...
i	i	i x 2
...
31	11111	31 x 2

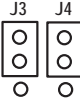

The following table describes the specification, terminals and jumpers of the MD38PG5/MD38PG5D.

MD38PG5 Specification		
User interface	Oblique terminal block	
Clearance	3.5 mm	
Screw	Flathead	
Pluggable	No	
Cable specification	16–26 AWG	
Max. frequency	100 kHz	
MD38PG5/ MD38PG5D Terminals		
No.	Mark	Description
1	A	Encoder output signal A
2	B	Encoder output signal B
3	Z	Encoder output signal Z
4	15V	Provide 15 V/100 mA power supply externally
5	COM	Power ground and frequency dividing ground
6	COM	Power ground and frequency dividing ground
7	A1	PG card frequency dividing output signal A (OC output, 0 to 24 V, 0 to 50 mA)
8	B1	PG card frequency dividing output signal B (OC output, 0 to 24 V, 0 to 50 mA)
9	PE	Shield connecting point
MD38PG5/ MD38PG5D Jumpers		
J3, J4	Jumper Position	Description
	Shorting pins 1 and 2	Not supporting the "pulse + direction" function (default setting)
	Shoring pins 2 and 3	Supporting the "pulse + direction" function

The following table describes the specification, terminals and jumpers of the MD38PG6/MD38PG6D.

MD38PG6 Specification	
User interface J3	DB9 female plug
Pluggable	Yes
Cable specification	> 22 AWG
Max. frequency	500 kHz
Differential input limit	≤ 7 V
User interfaces J7, J8	Oblique terminal block
Clearance	3.5 mm
Screw	Flathead
Pluggable	No
Frequency dividing rate	500 kHz
Frequency dividing range	4 to 62 (even number)

MD38PG1 Terminals		
No.	Mark	Description
1	A+	Encoder output signal A positive
2	A-	Encoder output signal A negative
3	B+	Encoder output signal B positive
4	B-	Encoder output signal B negative
5	Z+	Encoder output signal Z positive
6	Z-	Encoder output signal Z negative
7	5V	Provide 5 V/100 mA power supply externally
8	COM	Power ground
9	PE	Shield connecting point

MD38PG1 Jumpers		
CN3, CN4	Jumper Position	Description
	Shorting pins 1 and 2	Not supporting the "pulse + direction" function (default setting)
	Shorting pins 2 and 3	Supporting the "pulse + direction" function

The following table describes the specification and terminals of the MD38PG4.

MD38PG4 Specification	
User interface	DB9 female plug
Pluggable	Yes
Cable specification	> 22 AWG
Resolution	12-bit
Excitation frequency	10 kHz
VRMS	7 V
VP-P	3.15 ± 27%

MD38PG4 Terminals		
No.	Mark	Description
1	EXC1	Resolver excitation negative
2	EXC	Resolver excitation positive
3	SIN	Resolver feedback SIN positive
4	SINLO	Resolver feedback SIN negative
5	COS	Resolver feedback COS positive
6	-	
7	-	
8	-	
9	COSLO	Rotary encoder feedback COS negative

9.2.9 Extension Encoder Cards

The MD500 provides multiple types of encoder extension cards (PG cards) for your choice. The PG card is necessary for closed-loop vector control. Select a proper PG card according to the encoder output mode. The PG card models are listed in the following table.

PG Card	Description	Others
MD38PG1	Differential input PG card with frequency dividing output	Terminal wiring
MD38PG4	Resolver PG card with 1:1 frequency dividing output	DB9 female plug
MD38PG5	OC input PG card with 1:1 frequency dividing output	Terminal wiring
MD38PG5D	OC input PG card with selectable frequency dividing output	Terminal wiring
MD38PG6	Differential input PG card with 1:1 frequency dividing output	DB9 female plug
MD38PG6D	Differential input PG card with selectable frequency dividing output	DB9 female plug

■ Physical Appearance

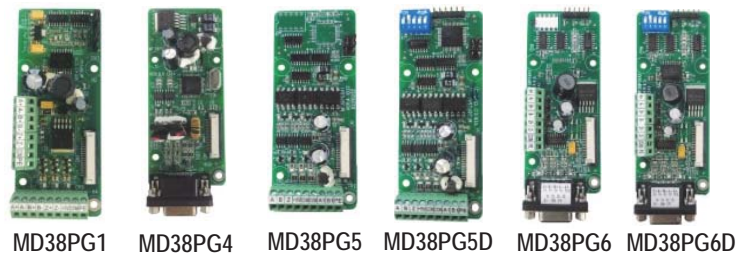

■ Mechanical Installation

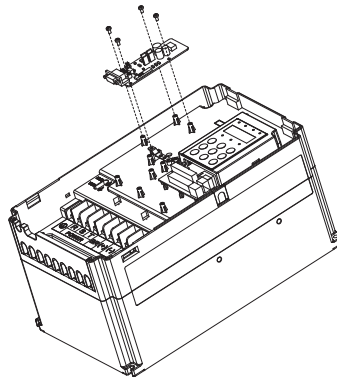

■ Description of Terminals and Jumpers

The following table describes the specification, terminals and jumpers of the MD38PG1.

MD38PG1 Specification	
User interface	Oblique terminal block
Clearance	3.5 mm
Screw	Flathead
Pluggable	No
Cable specification	16 to 26 AWG
Max. frequency	500 kHz
Differential input limit	≤ 7 V