

9.2.7 Extension CANopen Card (MD38CAN2)

■ Overview

MD38CAN2 is designed to connect the MD500 drive to the high-speed CANopen bus. The CANopen is an international field bus standard. The equipments supporting this protocol can be connected to the CANopen bus.

The MD38CAN2 supports the following five protocols:

1. The Node Guard protocol, with which the master can read the equipment status
2. The Heartbeat protocol, with which the slave reports the current state to the master regularly
3. The SDO that supports accelerated transmission mechanism only and transmits one function code (two bytes)
4. Three TPDOs and three RPDOs
5. **Emergency object.**

■ Physical Appearance

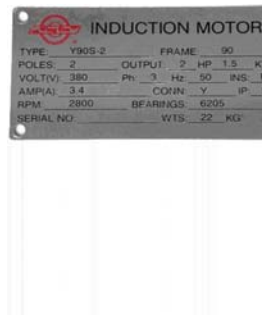

■ Mechanical Installation

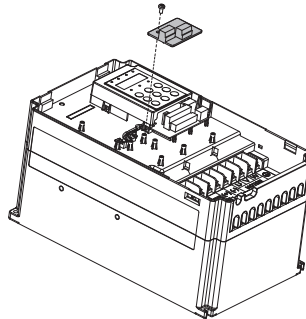

The MD38CAN2 has the same installation mode as the MD38IO2 does.

■ Description of Terminals and Jumpers

The following table describes the terminals of the MD38CAN2.

Type	Terminal	Terminal Name	Function Description
CAN communication terminal	CANH	CAN positive input	Connect to the positive pole of the CAN bus.
	CANL	CAN negative input	Connect to the negative pole of the CAN bus.
	COM	Power ground	Connect to the reference ground of all CAN nodes.

The following table describes the jumpers of the MD38CAN2.

Jumper	Description	Meaning	Setting
J2	CANopen terminal resistor matching selection	Matching the terminal resistor	
		Not matching the terminal resistor	

Note

The setting of the jumpers takes the top view with the main terminals at the bottom of the card as the visual angle. The jumpers are silk-screened on the card.

■ DIP Switch Setting

The DIP switches S2 and S3 of the MDCAN2 form a 8-bit DIP switch to set the CAN bus baud rate and communication equipment address. As shown in the following figure, bits 1 and 2 are used to set the baud rate, while bits 3 to 8 are used to set the CANopen address. When the DIP switch is set to ON, it indicates 1. When the DIP switch is set to OFF, it indicates 0.

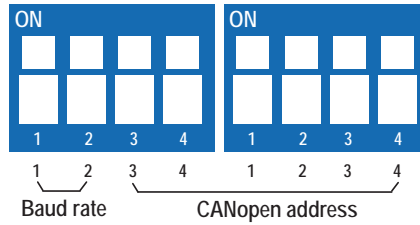

You can set the baud rate via the DIP switch according to the following table.

Bit Setting		Baud Rate
1	2	
0	0	125 kbps
0	1	250 kbps
1	0	500 kbps
1	1	1 Mbps

The bits 3 to 8 are used to set the CANopen communication address. 3 is the highest bit and 8 is the lowest bit. You can set the communication address 1 to 63 through these six bits according to the following figure.

Bit Setting						Communication Address
3	4	5	6	7	8	
0	0	0	0	0	0	Reserved
0	0	0	0	0	1	1
0	0	0	0	1	0	2
0	0	0	0	1	1	3
...						...
1	1	1	1	1	1	63

■ Indicators

Indicator	State	Description
PWR (in red)	ON	Power-on is normal.
	OFF	Power-on is abnormal. Check whether the installation is proper.
ERR (in red)	ON	The communication of the AC drive times out.
	Flashing quickly	The CANopen address is set incorrectly.
	Flashing twice	The CANopen messages emergently.
RUN (in green)	ON	The CANopen enters the "Operational" state.
	Flashing	The CANopen enters the "Pre-Operational" state.
	OFF	The CANopen enters the "Stopped" state.

■ Terminal Wiring

For wiring and use of the terminals of CANopen Card, see the terminal wiring part in the section 9.2.6 Extension CANlink Card (MD38CAN1).

If you purchase the MD38CAN2 card, the related user manual will be delivered together with the product. See the user manual for details.