

9.2.6 Extension CANlink Card (MD38CAN1)

■ Overview

MD38CAN1 is designed to connect the MD500 drive to the high-speed CANlink bus. It complies with the CANlink bus standard.

CANlink is based on CAN bus and developed by Inovance. It is an open communication protocol and the equipments supporting this protocol can be connected to the CANlink bus. The products of Inovance such as AC drive, servo drive, HMI and PLC can be connected to the CANlink bus seamlessly.

■ Physical Appearance



■ Mechanical Installation

The MD38CAN1 has the same installation mode as the MD38IO2 does.

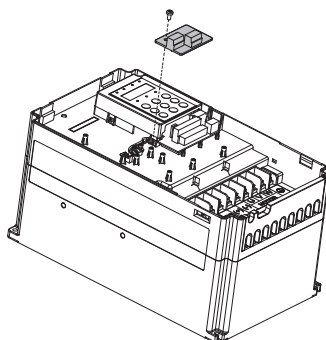

■ Description of Terminals and Jumpers

The following table describes the terminals of the MD38CAN1.

Type	Terminal	Terminal Name	Function Description
CAN communication terminal	CANH	CAN positive input	Connect to the positive pole of the CAN bus.
	CANL	CAN negative input	Connect to the negative pole of the CAN bus.
	COM	Power ground	Connect to the reference ground of all CAN nodes.

The following table describes the jumpers of the MD38CAN1.

Jumper	Description	Meaning	Setting
J2	CANlink terminal resistor matching selection	Matching the terminal resistor	<input type="checkbox"/> <input type="checkbox"/>
		Not matching the terminal resistor	<input type="checkbox"/> <input type="checkbox"/>

Note

The setting of the jumpers takes the top view with the main terminals at the bottom of the card as the visual angle. The jumpers are silk-screened on the card.

When applying the CANlink communication, connect a terminal resistor to the end AC drive and short pins 1 and 2 of the jumper J2.

■ Terminal Wiring

The CANlink bus topology is shown in the following figure.

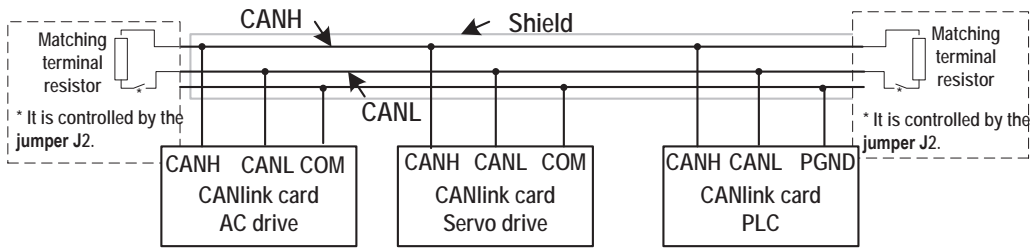

It is recommended to use an STP cable as the CAN bus and use a twisted cable to connect CANH and CANL. Connect a matching terminal resistor of 120 Ω respectively at both ends of the bus to prevent signal reflection. The CAN bus allows connection of a maximum of 64 nodes and the distance of each node branch must be smaller than 0.3 m. Connect the reference ground of all nodes together.

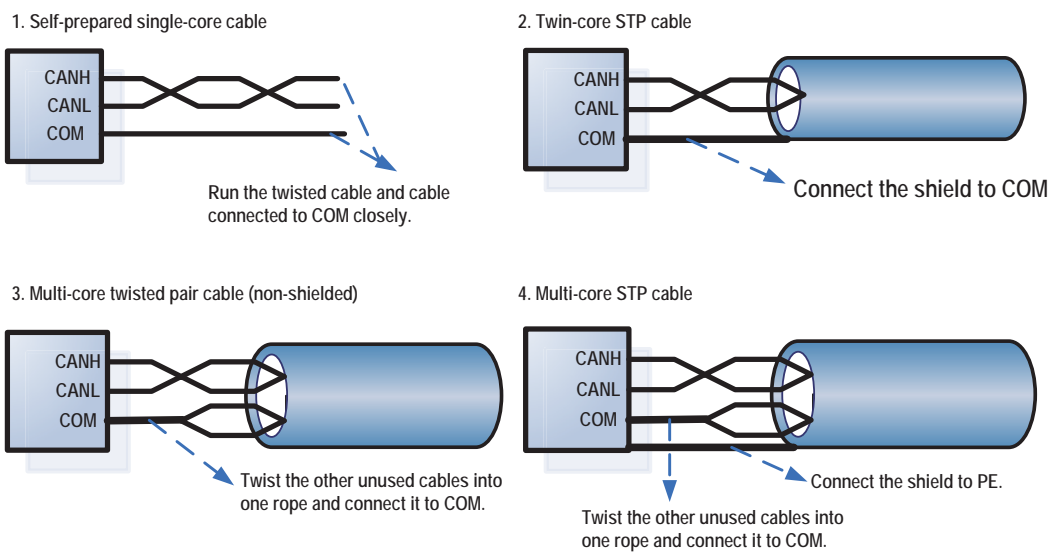

■ CANlink Transmission Distance

The transmission distance of the CANlink bus is directly related to the baud rate and communication cable. The relationship between the maximum transmission distance of the CANlink bus and the baud rate is shown in the following table.

No.	Max. Transmission Distance	Baud Rate	Number of Nodes	Cable Diameter
1	25 m	1 Mbps	64	0.205 mm ²
2	95 m	500 kbps	64	0.34 mm ²
3	560 m	100 kbps	64	0.5 mm ²
4	1100 m	50 kbps	64	0.75 mm ²