

Toshiba E3 Landies & Staefa FLN Interface Manual

**HIGH PERFORMANCE ADJUSTABLE SPEED DRIVE
QUIET ASD SERIES**

TOSHIBA



VARIABLE TORQUE ADJUSTABLE SPEED DRIVE

**LANDIS & STAEFA FLN
COMMUNICATIONS INTERFACE MANUAL**

TOSHIBA

Introduction

Thank you for purchasing the “Landis & Staefa FLN Communications Interface” for the Toshiba E3 Quiet Transistor Adjustable Speed Drive (ASD). This communications interface allows the E3 ASD to connect directly to the FLN communication network. Before using the Landis & Staefa FLN interface, please be sure to thoroughly read the instructions and precautions contained in this manual. In addition, please make sure that this instruction manual is delivered to the end user of the drive unit into which the communications interface is installed, and keep this instruction manual in a safe place for future reference or drive inspection.

This instruction manual describes the device specifications, installation and wiring methods, maintenance procedures, I/O point map and functions for the E3 FLN communications interface.

Please note that this communications interface can also be used in other Toshiba 3-series adjustable speed drives, such as the G3. Not all functions may be accessible, however, in other units. These exceptions will be noted where applicable. Also, use of this communication interface in other Toshiba 3-series drives may require the use of an additional plug-in communications option ROM. For more information regarding the required combinations of adjustable speed drives, interface boards and option ROMs, please contact your local distributor or Toshiba International Corporation.

TOSHIBA

Usage Precautions

Operating Environment

- Please use the communications interface only when the ambient temperature of the drive unit into which the interface is installed is within the following specified temperature limits:
Operation: -10 ~ +40°C (+14 ~ +104°F)
Storage: -25 ~ +65°C (-13 ~ +149°F)
- Avoid installation locations that may be subjected to large shocks or vibrations.
- Avoid installation locations that may be subjected to rapid changes in temperature or humidity.

Installation · Wiring

- Do not touch charged parts such as the terminal block while the drive's CHARGE lamp is lit. A charge will still be present in the drive unit's internal electrolytic capacitors, and therefore touching these areas may result in an electrical shock. Always turn all drive input power supplies OFF, and wait at least 5 minutes after the CHARGE lamp has gone out before wiring the communication cables or motor wiring.
- When installing the communications interface into the drive and making wiring connections, make certain that no clippings or wiring leads that could cause device failure fall into the drive or onto electronic components.
- Proper ground connections are vital for both safety and signal reliability reasons. For proper grounding procedures, please refer to the section in this manual pertaining to grounding (section 2).
- Route the communication cables separate from the drive input/output power wiring.
- To avoid the possibility of electric shock due to leakage currents, always ground the drive unit's E/GND terminal and the motor. To avoid misoperation, do not connect the communication interface's SHIELD terminal to either of the above-mentioned grounds or any other power ground.

Other Precautions

- The drive's EEPROM has a life span of 10,000 write cycles. Do not write to points #1, #30 ~ #32, points #34 ~ #37, point #61, point #63, points #66 ~ #69 or point #70 more than 10,000 times.
- Do not touch or insert a rod or any other item into the drive while power is applied, as this may lead to electrical shock or drive damage.
- Commission the disposal of the communications interface to a specialist.
- Do not assign the same address to more than one drive in the same network.
- Individual device addresses can be set from 1 ~ 98. Addresses larger than 98 are invalid and will cause the drive to trip "ErrE" (communication interface error).
- When the drive's control power supply is turned on, the drive performs initialization functions for approximately 3 seconds, during which communications capabilities are disabled. Communications capabilities will also be disabled for approximately 3 seconds after momentary control power supply outages or drive resets.

TABLE OF CONTENTS

1.	Interface Board Installation / Removal.....	4
1.1	Installation Procedure	4
1.2	Removal.....	7
2.	Grounding.....	9
3.	Environmental Specifications	9
4.	Maintenance And Inspection	10
5.	Storage And Warranty	11
5.1	Storage.....	11
5.2	Warranty	11
6.	FLN Interface Configuration	12
6.1	FLN Network Connections.....	12
6.2	Hardware Configuration.....	12
7.	E3 Parameter Settings	13
8.	Network Programming Interface.....	14
8.1	Point Summaries	14
8.2	Point Map.....	15
8.3	Individual Point Descriptions	20
8.3.1	<i>Logical Analog Input Points.....</i>	<i>20</i>
8.3.2	<i>Logical Digital Input Points.....</i>	<i>21</i>
8.3.3	<i>Logical Analog Output Points.....</i>	<i>22</i>
8.3.4	<i>Logical Digital Output Points.....</i>	<i>25</i>
9.	Drive Fault Codes	26
10.	Notes	28





TOSHIBA

1. Interface Board Installation / Removal

The E3 adjustable speed drive does not require any additional hardware components other than the Landis & Staefa FLN communications interface board in order to connect to and communicate with the FLN network. This portion of the manual will detail the procedure used to install and remove the interface board. If at any time you experience problems during the installation / removal process, please call Toshiba International Corporation for assistance.

1.1 Installation Procedure

Installation of the FLN communications interface board into an E3 drive should only be performed by a qualified technician familiar with the maintenance and operation of the E3. To install the interface board, complete the following steps:

1.  **CAUTION!** Verify that all input power sources to the drive have been turned OFF and are locked and tagged out.
2.  **DANGER!**  Wait at least 5 minutes for the drive's electrolytic capacitors to discharge before proceeding to the next step. **Do not touch any internal parts with power applied to the drive, or for at least 5 minutes after power to the drive has been removed. A hazard exists temporarily for electrical shock even if the source power has been removed.**
3.  Remove the drive's cover (open the door on units with hinged doors). Verify that the CHARGE LED has gone out before continuing the installation process.
4. Loosen the 4 screws attaching the E3's operation panel support bracket to the control board support bracket, and then remove the operation panel and support bracket as a unit (refer to Figure 1).
5. Install the 4 nylon standoffs into the holes provided in the control board support bracket (refer to Figure 2).
6. Install the FLN network cable through the access holes at the bottom of the drive and route the cable in order to make connections to the interface board connector (TB1). Take care to not route the cable near any sharp edges or in positions where it may be pinched.

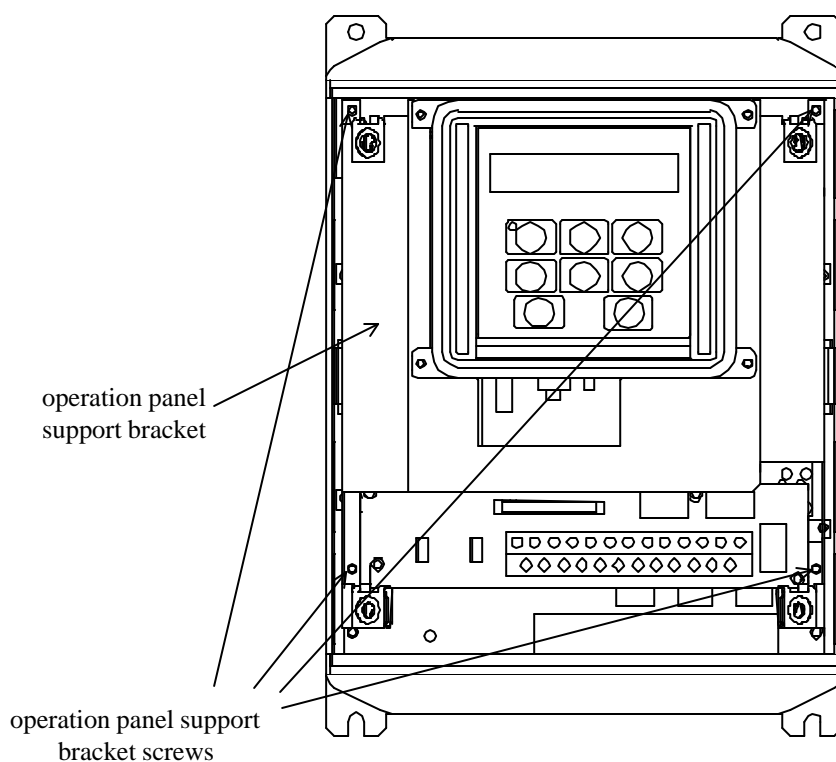

Figure 1: E3 with front cover removed

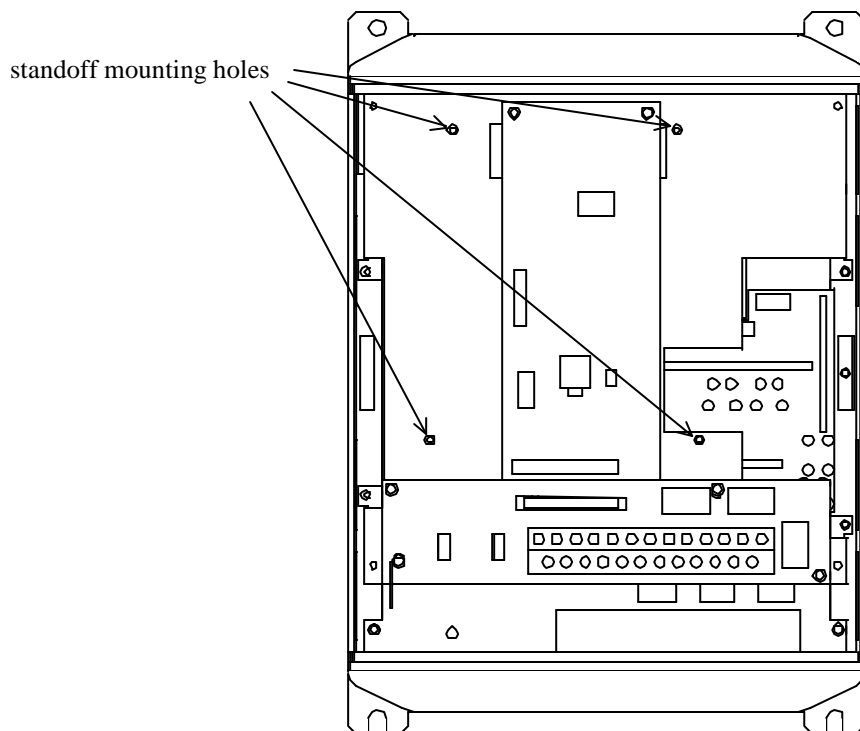





Figure 2: E111 with front cover and operation panel support bracket removed

TOSHIBA

7.  **CAUTION!** The FLN interface board is a static-sensitive device. Standard electrostatic-sensitive component handling precautions should be observed. Connect the FLN network cable to the interface board connector (TB1). For more information on making connections to the FLN network, refer to section 6.1 on page 12.

 **CAUTION!** Extremely high voltages exist in the area near the interface board and connector (TB1) once installed in the E3. Ensure that no stray wires (such as the shield on the FLN network cable) come into contact with any internal drive components. Also ensure that the FLN network cable is not routed in such a manner that it may come into contact with high-voltage drive components, or drive components that may heat up during operation and damage the cable insulation.

8. Install the interface board into the drive by carefully aligning the 4 nylon standoffs with the 4 mounting holes provided in the interface board. Ensure that connector CN5A on the back side of the interface board is aligned with connector CN5 on the front side of the control board.
9. Press the interface board firmly onto the standoffs and connector CN5 until the standoff retaining tabs lock. Ensure that CN5 and CN5A are thoroughly interlocked.
10. Carefully re-install the operation panel and support bracket and tighten the 4 screws that attach the operation panel support bracket to the control board support bracket.
11. Reinstall the drive's cover (close and latch the door on units with hinged doors).

 **DANGER!**  **Do not operate the unit with the cover off / cabinet door open.**





12. Turn all power sources to the drive unit ON, and verify that the drive functions properly. If the drive unit does not appear to power up, or does not function properly, immediately turn power OFF. **Repeat steps 1 ~ 3 to remove all power from the drive.** Then, verify all connections. Contact Toshiba International Corporation for assistance if the problem persists.



TOSHIBA

1.2 Removal

Removal of the Landis & Staefa FLN interface board from an E3 ASD should only be performed by a qualified technician familiar with the maintenance and operation of the E3. In order to protect the interface board connector's reliability, do not repeatedly connect and disconnect the interface. Use the following procedure if it becomes necessary to remove the Landis FLN interface board from the drive.

 **CAUTION!** Do not remove the interface board while power is applied to the drive. Removing the interface board with power applied may damage the drive.

1.  **CAUTION!** Verify that all input power sources to the drive have been turned OFF and are locked and tagged out.
2.  **DANGER!**  Wait at least 5 minutes for the drive's electrolytic capacitors to discharge before proceeding to the next step. **Do not touch any internal parts with power applied to the drive, or for at least 5 minutes after power to the drive has been removed. A hazard exists temporarily for electrical shock even if the source power has been removed.**
3.  Remove the drive's cover (open the door on units with hinged doors). Verify that the CHARGE LED has gone out before continuing the removal process.
4. Loosen the 4 screws attaching the operation panel support bracket to the control board support bracket and remove the operation panel and support bracket as a unit (refer to Figure 3).
5.  **CAUTION!** The Landis & Staefa FLN interface board is a static-sensitive device. Standard electrostatic-sensitive component handling precautions should be observed. Release the 4 corners of the interface board from the standoffs by pressing down on the standoff locking tabs with a small flat-headed screwdriver. Be careful to not apply any abnormal stress to the interface board while performing this, as this may damage the interface board or control board connectors.
6. Remove the interface board from the drive.
7. Disconnect the FLN network cable from the interface board connector (TB1), and pull the cable out through the access holes at the bottom of the drive.
8. Carefully re-install the operation panel and support bracket and tighten the 4 screws that attach the operation panel support bracket to the control board support bracket.
9. Reinstall the drive's cover (close and latch the door on units with hinged doors).

 **DANGER!**  Do not operate unit with the cover off / cabinet door open.

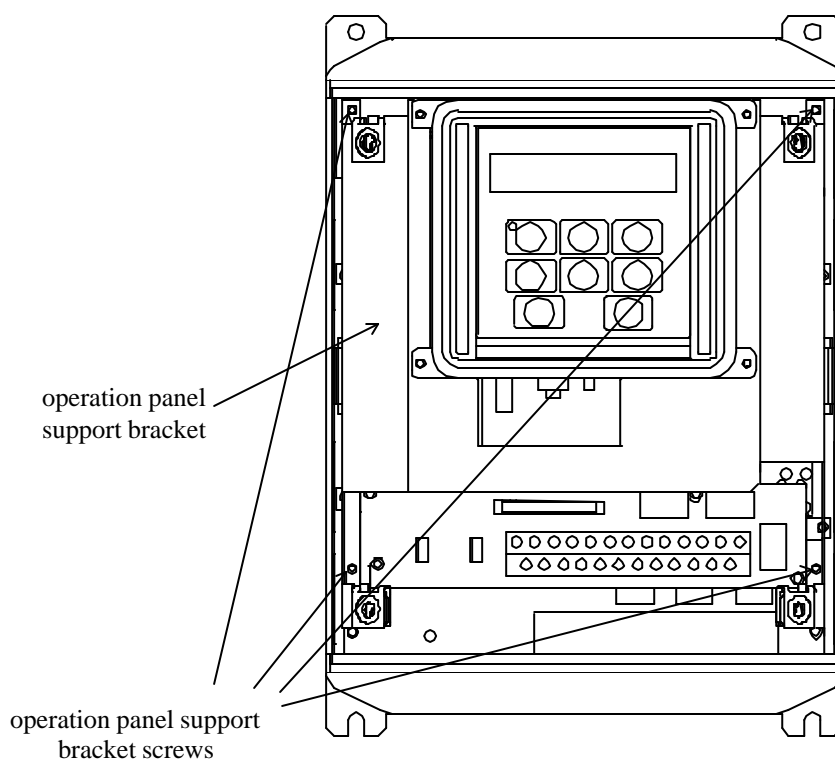

Figure 3: *EIII with front cover removed*

10. Turn all power sources to the unit ON, and verify that the drive functions properly. If the drive does not appear to power up, or does not function properly, immediately turn power OFF. **Repeat steps 1 ~ 3 to remove all power from the drive.** Then, verify all connections. Contact Toshiba International Corporation for assistance if the problem persists.

TOSHIBA

2. Grounding

Grounding is of particular importance for reliable, stable operation. Communication system characteristics may vary from system to system, depending on the system environment and grounding method used. A ground connection with impedance of less than 100Ω should be used. Please be sure to consider the following points for making proper ground connections:

Grounding method checkpoints

1. Make all ground connections such that no ground current flows through the drive's case.
2. Ensure that all grounds are connected to points that are at the same potential as drive grounds.
3. Do not connect the Landis & Staefa FLN interface board's SHIELD terminal to a power ground or any other potential noise-producing ground connection (such as the drive's E/GND terminal).
4. Do not make connections to unstable grounds (paint-coated screw heads, grounds that are subjected to inductive noise, etc.)
5. Use copper wire with a cross-sectional area of 2mm² or larger, or aluminum wire with a cross-sectional area of 2.6mm² or larger for grounding.

3. Environmental Specifications

Item	Specification
Operating Environment	Indoors, less than 1000m above sea level, do not expose to direct sunlight or corrosive / explosive gasses.
Operating Temperature	-10 ~ +40°C (+14 ~ +104°F)
Storage Temperature	-25°C ~ +65°C (-13 ~ +149°F)
Relative Humidity	20% ~ 90% (without condensation)
Vibration	5.9m/s ² {0.6G} or less (10 ~ 55Hz)
Grounding	Use a ground connection with impedance of less than 100Ω.
Cooling Method	Self-cooled

TOSHIBA

4. Maintenance And Inspection

Preventive maintenance and inspection is required to maintain the Landis & Staefa FLN communications interface in its optimal condition, and to ensure a long operational lifetime. Depending on usage and operating conditions, perform a periodic inspection once every three to six months. Before starting inspections, always turn off all power supplies to the drive unit, and wait at least five minutes after the drive's "CHARGE" lamp has gone out.

**DANGER!**

Do not touch any internal parts with power applied to the drive, or for at least 5 minutes after power to the drive has been removed. A hazard exists temporarily for electrical shock even if the source power has been removed.

Inspection Points

- Check that the wiring terminal screws are not loose. Tighten if necessary.
- Check that there are no defects in any wire terminal crimp points. Visually check that the crimp points are not scarred by overheating.
- Visually check the wiring and cables for damage.
- Clean off any accumulated dust and dirt. Place special emphasis on cleaning all installed PCBs and the ventilation ports of the drive. Always keep these areas clean, as adherence of dust and dirt can cause premature component failure.
- If use of the drive unit is discontinued for extended periods of time, turn the power on at least once every two years and confirm that the unit still functions properly.
- Do not perform hi-pot tests on the drive or Landis & Staefa FLN interface board, as they may damage the unit's internal components.

Please pay close attention to all periodic inspection points and maintain a good operating environment.

TOSHIBA

5. Storage And Warranty

5.1 Storage

Observe the following points when the Landis & Staefa FLN interface is not used immediately after purchase or when it is not used for an extended period of time.

- Avoid storing the interface board in places that are hot or humid, or that contain large quantities of dust or metallic dust. Store the interface board in a well ventilated location.
- When not using the interface board for an extended period of time, turn the power on at least once every two years and confirm that it still functions properly.

5.2 Warranty

The E3 Landis & Staefa FLN Communications Interface Kit is covered under warranty for a period of 12 months from the date of installation, but not to exceed 18 months from the date of shipment from the factory. For further warranty or service information, please contact Toshiba International Corporation.

6. FLN Interface Configuration

6.1 FLN Network Connections

Each E3 Landis & Staefa FLN interface board can be directly connected to the FLN network by using twisted-pair cable connected as shown in Figure 4. Connect the '+' wire to terminal "A", the '-' wire to terminal "B", and the network cable shield to the "SHIELD" terminal on the interface board's TB1 terminal block. Continue this connection scheme throughout the remainder of the network. Always connect each unit in a daisy-chain fashion, without drop lines, star configurations, etc. For further FLN network wiring requirements and procedures, please refer to the appropriate Landis & Staefa FLN network installation and configuration documentation.

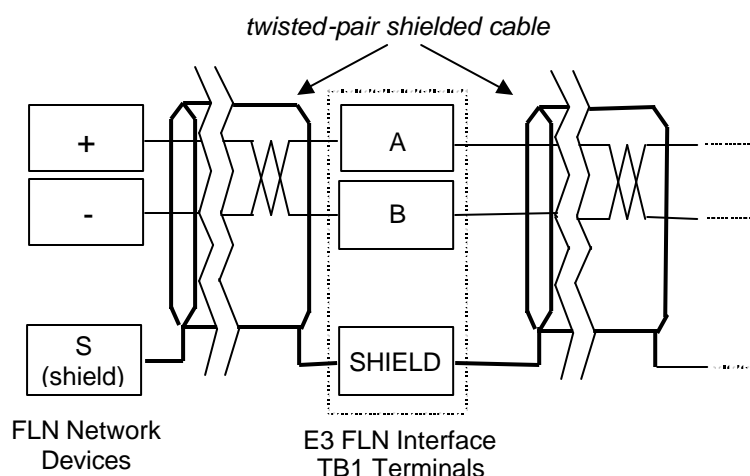

Figure 4. *FLN network Cable Connection*

6.2 Hardware Configuration

Other than installing the interface board and connecting the FLN network cable, the only other hardware configuration required is whether or not to terminate the FLN network at each individual interface board. A jumper on the interface board (labeled "JP1") determines whether or not the FLN network is terminated at the interface board (termination is a 121Ω resistor). Only the 2 devices at the extreme ends of the FLN network should have JP1 set to "TERM". All other devices should have JP1 set to "OPEN".

The 8-position DIP switch (labeled SW1) located on the right-hand side of the interface board is not used, and its switch settings are therefore irrelevant.

TOSHIBA

7. E3 Parameter Settings

FLN interface communications are enabled by setting parameter `OPt` in `GrpE` to 2 (FLN / Metasys / Modbus/ Tosline-F10). No other Tosline-F10 communication parameter settings apply when using the Landis & Staefa FLN interface. When using any communication interface on the E3 drive, the frequency command and command input received from the network can be enabled by setting parameters `FNOd` and `ENOd`, respectively, in `GrpE` to 3. For more information on methods for changing parameter settings, refer to the TOSHIBA [E3 Operation Manual](#).

IMPORTANT: *The standard factory setting for parameter `lna` is 0, which is reserved for Landis and Staefa's use. Be sure to set this value to a valid address prior to attempting to connect to the drive via a field panel. Also, if this parameter is set to a value higher than 98, the drive will trip "Err8" (communication interface card error) upon reset / initialization.*

The following is a list of the parameters settings that are required during setup to enable FLN communications:

Parameter	Group	Required Value
<code>bLnd</code>	<code>GrpE</code>	1
<code>bLEr</code>	<code>GrpE</code>	1
<code>OPt</code>	<code>GrpE</code>	2
<code>lna</code>	<code>GrpE</code>	any value less than 99

As is the same with all other communication configuration parameters, the drive must be reset after making the parameter changes described above in order for the changed settings to be enabled.

If the E3 drive into which a Landis & Staefa FLN communication interface board is installed trips "Err8" (communication interface card error) for any reason during initialization or operation, it is incapable of being reset via the FLN network. When this trip condition occurs, therefore, the drive can only be reset locally via the panel or control terminal block.

If drive control (frequency command input, RUN/STOP, etc.) is to be performed via setting Logical Analog Output (LAO) and Logical Digital Output (LDO) points from the FLN network, the following drive parameters must also be set as shown:

Parameter	Group	Required Value
<code>ENOd</code>	<code>GrpE</code>	3
<code>FNOd</code>	<code>GrpE</code>	3

TOSHIBA

8. Network Programming Interface

8.1 Point Summaries

The E3 Landis & Staefa FLN interface has a predefined set of logical analog and logical digital I/O points used for controlling the drive and for monitoring status items. These points can be summarized as follows:

- Logical Analog Input (LAI) points are used for monitoring drive status items such as output frequency, current and voltage. The E3 supports 16 different logical analog input points. Change of value (COV) of logical analog input points can be enabled (LAI points are capable of being characterized). Logical analog input points will respond to write point and memorize point commands, but will not change their actual values or indicate override active.
- Logical Analog Output (LAO) points are used for setting and monitoring control points such as the drive's frequency command and configuration parameters. The E3 supports 17 different logical analog output points (13 of them are for the E3's parameters and commands, while another 4 special ones are reserved for maintaining compliance with Landis & Staefa's products). The values of all logical analog output points can be modified by issuing write point or memorize point commands. Issuing release commands will not cause the logical analog output points to automatically return to their pre-override values, nor will the logical analog output points automatically return to their pre-override values after a certain time period of no communication. LAO points do not support COV.
- Logical Digital Input (LDI) points are used for monitoring drive status items such as terminal ON/OFF conditions and fault status. The E3 supports 19 different logical digital input points. All logical digital input points support COV (LDI points are capable of being characterized). Logical digital input points will respond to write point and memorize point commands, but will not change their actual values or indicate override active.
- Logical Digital Output (LDO) points are used for executing drive commands such as RUN/STOP and trip clear. The E3 supports 11 different logical digital output points (10 among them are for drive control, while one special point is reserved for maintaining compliance with Landis & Staefa's products). The values of all logical digital output points can be modified by issuing write point or memorize point commands. Issuing release commands will not cause the logical digital output points to automatically return to their pre-override values, nor will the logical digital output points automatically return to their pre-override values after a certain time period of no communication. LDO points do not support COV.

The device type for the E3 FLN interface is terminal equipment controller (TEC).

TOSHIBA

8.2 Point Map

LPT ¹	LPN ²	POINT DESCRIPTION	English Units	Slope	Intercept	On Text	Off Text	Factory Default	Range / Value
LAO	1	CTRL ADDRESS	-	1	0	-	-	0	0 ~ 98
LAO	2	APPLICATION	-	1	0	-	-	2714	--
{LAI}	3	FREQ.OUTPUT	HZ	0.02	0.00	-	-	-	0.00 ~ 400.00
{LAI}	4	LOAD CURRENT	PCT	1	0	-	-	-	0 ~ 255
{LAI}	6	IV TERMINAL	PCT	0.01	0.00	-	-	-	0.00 ~ 100.00
{LAI}	7	RR TERMINAL	PCT	0.01	0.00	-	-	-	0.00 ~ 100.00
{LAI}	8	RX TERMINAL	PCT	0.01	-100.00	-	-	-	-100.00~ 100.00
{LAI}	9	INPUT POWER	KW	0.2	0.0	-	-	-	0.0 ~ 6553.4
{LAI}	10	OUTPUT POWER	KW	0.2	-3276.8	-	-	-	-3276.8~3276.7
{LAI}	11	DRIVE.KWH	KWH	0.1	0.0	-	-	-	0.0 ~ 999.9
{LAI}	12	DRIVE.MWH	MWH	2	0	-	-	-	0 ~ 65535
{LAI}	13	INPUT VOLT	PCT	0.1	0.0	-	-	-	0.0 ~ 255.0
{LAI}	14	OUTPUT VOLT	PCT	0.1	0.0	-	-	-	0.0 ~ 232.0
{LAO}	20	OVRD TIME	HRS	1	0	-	-	-	0 ~ 255
{LDI}	21	REV.FWD	-	-	-	FWD	REV	REV	0=reverse 1=forward
{LDO}	22	CMD REV.FWD	-	-	-	FWD	REV	REV	0=reverse 1=forward

TOSHIBA

LPT ¹	LPN ²	POINT DESCRIPTION	English Units	Slope	Intercept	On Text	Off Text	Factory Default	Range / Value
{LDI}	23	STOP.RUN	-	-	-	RUN	STOP	STOP	0=stopped 1=running
{LDO}	24	CMD STOP.RUN	-	-	-	RUN	STOP	STOP	0=stop 1=run
{LDI}	25	ACC.DEC STAT	-	-	-	TWO	ONE	ONE	0=accel/decel #1 1=accel/decel #2
{LDO}	26	ACC.DEC 1.2	-	-	-	TWO	ONE	ONE	0=accel/decel #1 1=accel/decel #2
{LDI}	27	COAST STATUS	-	-	-	ON	OFF	OFF	0=normal 1=coast to stop
{LDO}	28	CMD COAST	-	-	-	ON	OFF	OFF	0=no gate block 1=gate block
{LDO}	29	DAY.NGT	-	-	-	NIGHT	DAY	DAY	--
LAO	30	CURRENT LIM	PCT	1	10	-	-	110	10 ~ 215
LAO	31	ACCEL TIME 1	SEC	0.1	0.1	-	-	60.0	0.1 ~ 600.0
LAO	32	DECEL TIME 1	SEC	0.1	0.1	-	-	60.0	0.1 ~ 600.0
LAO	34	COMMAND MODE	-	1	0	-	-	4	0 ~ 4
LAO	35	FREQ MODE	-	1	0	-	-	4	0 ~ 4
LAO	36	TIMEOUT TIME	SEC	0.1	0.1	-	-	1.000	0.1 ~ 1000.0
LAO	37	TIMEOUT ACT	-	1	0	-	-	0	0 ~ 4
{LDI}	38	DC INJ STAT	-	-	-	ON	OFF	OFF	0=inactive 1=active

TOSHIBA

LPT ¹	LPN ²	POINT DESCRIPTION	English Units	Slope	Intercept	On Text	Off Text	Factory Default	Range / Value
{LDO}	39	CMD DC INJ	-	-	-	ON	OFF	OFF	0=no DC braking 1=DC braking
{LDI}	49	FL CONTACT	-	-	-	ON	OFF	OFF	0=FLB-FLC shorted 1=FLA-FLC shorted
{LDI}	50	ST TERM	-	-	-	ON	OFF	OFF	0=terminal-CC open 1=terminal-CC shorted
{LDI}	51	LOW CONTACT	-	-	-	ON	OFF	OFF	0=LOWA-LOWC open 1=LOWA-LOWC shorted
{LDI}	52	RCH OUTPUT	-	-	-	ON	OFF	OFF	0=RCHA-RCHC open 1=RCHA-RCHC shorted
{LDI}	53	F TERM	-	-	-	ON	OFF	OFF	0=terminal-CC open 1=terminal-CC shorted
{LDI}	54	R TERM	-	-	-	ON	OFF	OFF	0=terminal-CC open 1=terminal-CC shorted
{LDI}	55	S1 TERM	-	-	-	ON	OFF	OFF	0=terminal-CC open 1=terminal-CC shorted
{LDI}	56	S2 TERM	-	-	-	ON	OFF	OFF	0=terminal-CC open 1=terminal-CC shorted

TOSHIBA

LPT ¹	LPN ²	POINT DESCRIPTION	English Units	Slope	Intercept	On Text	Off Text	Factory Default	Range / Value
{LDI}	57	S3 TERM	-	-	-	ON	OFF	OFF	0=terminal-CC open 1=terminal-CC shorted
{LDI}	58	S4 TERM	-	-	-	ON	OFF	OFF	0=terminal-CC open 1=terminal-CC shorted
{LDI}	59	RES TERM	-	-	-	ON	OFF	OFF	0=terminal-CC open 1=terminal-CC shorted
{LAO}	60	INPUT REF	HZ	0.02	0.00	-	-	0.00	0.00HZ~400.00HZ
LDO	61	PID CONTROL	-	-	-	ON	OFF	OFF	0=no feedback 1=feedback contl
LAO	63	P GAIN	-	0.01	0.01	-	-	0.30	0.01 ~ 2.55
{LDI}	64	PID ENA STAT	-	-	-	ENABLE	DISABL	ENABLE	0=feedback disabled 1=feedback enabled
{LDO}	65	PID ENABLE	-	-	-	DISABL	ENABLE	ENABLE	0=feedback enabled 1=feedback disabled
LAO	66	I GAIN	SEC	0.02	0.01	-	-	2.00	0.01 ~ 359.99
LAO	67	PID LO LIMIT	HZ	0.02	0.00	-	-	10.00	0~FH
LAO	68	PID DEV HI	PCT	1	0	-	-	10	0 ~ 50
LAO	69	PID DEV LO	PCT	1	0	-	-	10	0 ~ 50

LPT ¹	LPN ²	POINT DESCRIPTION	English Units	Slope	Intercept	On Text	Off Text	Factory Default	Range / Value
LDO	70	PID DEV LMT	-	-	-	ON	OFF	ON	0=PID deviation limit disabled 1=PID deviation limit enabled
{LDI}	90	FAULT STATUS	-	-	-	ON	OFF	OFF	0=E3 not faulted 1=E3 faulted
{LDI}	91	EOFF STATUS	-	-	-	ON	OFF	OFF	0=normal 1=emergency off
{LDO}	92	CMD EOFF	-	-	-	ON	OFF	OFF	0=no action 1=emergency off
{LAI}	93	PRESENTFAULT	-	1	0	-	-	-	0 ~ 82
{LAI}	95	TRIP 1 MON	-	1	0	-	-	-	0 ~ 82
{LAI}	96	TRIP 2 MON	-	1	0	-	-	-	0 ~ 82
{LAI}	97	TRIP 3 MON	-	1	0	-	-	-	0 ~ 82
{LAI}	98	TRIP 4 MON	-	1	0	-	-	-	0 ~ 82
{LAI}	99	ERROR STATUS	-	1	0	-	-	-	0 ~ 255

[NOTE 1]: LPT = Landis Point Type.

[NOTE 2]: LPN = Landis Point Number.

TOSHIBA

8.3 Individual Point Descriptions

This section gives a brief overview of each point (grouped into the four classes of LAI, LDI, LAO and LDO) including any notable behavior or settings. For those parameters outlined here that directly map to internal E3 configuration parameters, refer to the [E3 Operation Manual](#) for further information regarding their usage or behavior.

8.3.1 Logical Analog Input Points

LAI #3.....Indicates the drive's output frequency in Hz.

LAI #4.....Indicates the drive's output current in % (100% = drive rated current).

LAI #6.....Indicates the signal level currently being applied to the E3's IV analog input terminal. This can be used to monitor such items as feedback sensor outputs and other process variables.

LAI #7.....Similar to LAI #6, this object indicates the signal level currently being applied to the E3's RR analog input terminal.

LAI #8.....Similar to LAI #6, this object indicates the signal level currently being applied to the E3's RX analog input terminal.

LAI #9.....Indicates the E3's present input power usage (power consumed by the drive/motor system).

LAI #10.....Indicates the E3's present output power (power consumed by the motor).

LAI #11.....Indicates the E3/system energy consumption in KWh. This point must be used in conjunction with LAI #12 to arrive at an accurate representation of system energy consumption. Upon reaching 999.9 KWh, this point rolls over to 0.0 KWh, and the value of MWh (LAI #12) is incremented. Use this point only when the communications interface is installed in an E3 drive.

LAI #12.....Indicates the E3/system energy consumption in MWh. This point must be used in conjunction with LAI #11 to arrive at an accurate representation of system energy consumption. For example, if the value of LAI #11 is 456.3, and the value of LAI #12 is 34, the total system energy expenditure thus far is 34.4563 MWh, or 34,456.3 KWh. Use this point only when the communications interface is installed in an E3 drive.

LAI #13.....Indicates the drive's input voltage in % (100% = drive voltage class).

LAI #14.....Indicates the drive's output voltage in % (100% = drive voltage class).

LAI #93.....Indicates the present drive fault code (refer to section 9 for fault code meanings). Under normal drive operation (no faults), this value will be 0. When the FLN interface is installed in a 3-series adjustable speed drive other than the E3, the maximum value possible is 41.

LAI #95 ~ LAI #98..... Indicate the last 4 faults that occurred (refer to section 9 for fault code meanings). LAI #95 contains the fault code for the most recent saved fault and LAI #98 contains the fault code for the oldest saved fault. When a new fault occurs, the fault codes traverse down the fault stack, and the oldest fault is discarded. When the FLN interface is installed into a 3-series adjustable speed drive other than the E3, the maximum value possible for these points is 41.

TOSHIBA

8.3.2 Logical Digital Input Points

LDI #21.....Indicates whether the drive is running in the forward or reverse direction.

LDI #23.....Indicates whether the drive is running or stopped.

LDI #25.....Indicates whether the drive is currently using acceleration time #1 and deceleration time #1 or acceleration time #2 and deceleration time #2 when accelerating and decelerating.

LDI #27.....Indicates whether or not a coast-stop command was given to the E3.

LDI #38.....Indicates the status of compulsory DC injection braking. When using compulsory DC injection braking, the E3 will apply DC injection braking to the motor whenever the output frequency drops below the frequency value set in parameter d_{bF} in $\overline{C_r.P_r}$. This differs from standard DC injection braking in that with standard DC injection braking, the E3 will apply DC injection braking only when a stop command is given and the output frequency drops below the value set in parameter d_{bF} in $\overline{C_r.P_r}$.

LDI #49.....Indicates the current status of the “FL” output contacts.

LDI #50.....Indicates the current status of the “ST” input contact terminal.

LDI #51.....Indicates the current status of the “LOW” output contacts.

LDI #52.....Indicates the current status of the “RCH” output contacts. When the FLN interface is installed in a 3-series adjustable speed drive other than the E3, the RCH terminal may consist of dry contact closures. In this case, the value 0 corresponds to RCHA-RCHC open, and the value 1 corresponds to RCHA-RCHC closed.

LDI #53.....Indicates the current status of the “F” input contact terminal.

LDI #54.....Indicates the current status of the “R” input contact terminal.

LDI #55.....Indicates the current status of the “S1” input contact terminal.

LDI #56.....Indicates the current status of the “S2” input contact terminal.

LDI #57.....Indicates the current status of the “S3” input contact terminal.

LDI #58.....Indicates the current status of the “S4” input contact terminal.

LDI #59.....Indicates the current status of the “RES” input contact terminal.

LDI #64.....Indicates whether feedback control is enabled or not. Note that this LDI object does not necessarily indicate that feedback is active; in order to use feedback control, parameter FEEDBACK CONTROL SELECTION (LDO #61, or parameter F_{bP} in $\overline{C_r.F_b}$) must also be enabled. This LDI object only indicates the enable selection status of LDO #65.

LDI #90.....Indicates whether or not the E3 is currently faulted (any fault).

LDI #91.....Indicates whether or not the E3 is currently faulted “E0FF”.

TOSHIBA

8.3.3 Logical Analog Output Points

IMPORTANT: Most of the LAO objects detailed in this section map directly to E3 configuration parameters (parameters accessible via the E3's keypad). When these parameters are changed (from either the keypad or the FLN network), they are stored in the E3's non-volatile EEPROM (except those which are noted in the following point explanations). The E3's EEPROM has a life span of 10,000 write cycles per parameter; therefore do not write to any of these LAO objects more than 10,000 times.

LAO #1Accesses the E3's INVERTER NUMBER parameter (IN01 in Cr.Er).

LAO #30 ...Accesses the E3's STALL PROTECTION CURRENT LEVEL parameter (SEEL1 in Cr.Pr).

LAO #31 ...Accesses the E3's ACCELERATION TIME #1 parameter (ACCL1 in Cr.F). Note that the indicated range is different from the actual possible setting range of the E3. If the E3's panel is used to set the ACCL1 parameter to a value outside of the range indicated in the point table, the value as reported over the network will be limited to the indicated range extremes. Also, this point depends on the setting of E3 parameter dSPt in Cr.Ut. The value of dSPt is read by the FLN interface only on drive initialization; therefore, if the setting of dSPt is changed, be sure to reset the drive to validate the changed setting and provide correct network data interpretation.

LAO #32 ...Accesses the E3's DECELERATION TIME #1 parameter (dEEL1 in Cr.F). Note that the indicated range is different from the actual possible setting range of the E3. If the E3's panel is used to set the dEEL1 parameter to a value outside of the range indicated in the point table, the value as reported over the network will be limited to the indicated range extremes. Also, this point depends on the setting of E3 parameter dSPt in Cr.Ut. The value of dSPt is read by the FLN interface only on drive initialization; therefore, if the setting of dSPt is changed, be sure to reset the drive to validate the changed setting and provide correct network data interpretation.

LAO #34 ...Accesses the E3's COMMAND MODE SELECTION parameter (CMD in Cr.Ut). For FLN network commands to affect the E3's actual operation, this point must be set to a value of 3. Note that if the value of this point is changed while the E3 is running, the changed value will not take effect until the drive is stopped.

LAO #35 ...Accesses the E3's FREQUENCY MODE SELECTION parameter (FMD in Cr.Ut). For the frequency command (LAO #60) set via the FLN network to affect the E3's actual operation, this point must be set to a value of 3. Note that if the value of this point is changed while the E3 is running, the changed value will not take effect until the drive is stopped.

LAO #36 and LAO #37 ... The FLN interface provides a configurable "loss of communications" timer function, which can detect network communication losses and perform certain actions if a valid FLN packet is not received and processed within a set time period.

LAO #36 sets the loss of communication time value (adjustable from 0.1s to 1000.0s in 0.1s increments, factory setting = 1.0s). If a valid (error-free) FLN network reception-response cycle does not take place within this time limit,

TOSHIBA

the timer will expire. If the timer expires, 5 possible actions can occur, as set by the value of LAO #37 (loss of communications timeout action). These actions are summarized in the following table:

LAO #37 Setting	Action Taken Upon Timeout
0 (default)	No action: ignore timeout.
1	Flash "E" (communications warning indicator) on LED display only.
2	Flash "E" on LED display, stop E3 with decelerated stop.
3	Trip "ERR". Note that the E3 must be reset locally in this case.
4	Flash "E" on LED display, set LAO #60 (frequency command) to 400.00Hz (CAUTION!). Note that the actual internal frequency command will be limited by the UPPER LIMIT FREQUENCY parameter (UL in U.F).

Setting 0 is the default setting; when a communications timeout occurs, no action will be taken (timeout function is disabled).

For setting 1 (flash "E" on LED display only), this condition will continue until the next error-free FLN packet is received and responded to. The warning condition will then be removed and the timer value reset.

For setting 2 (flash "E" on LED display, stop drive with decelerated stop), the "E" warning will act as described in setting 1, but LDO #24 (run/stop command) will also be set to 0 (stop). Note that the drive stop condition will not be reset when an error-free FLN network packet is once again received and responded to. Also note that although LDO #24 is set to 0, this will cause the E3 to actually stop only if LAO #34 or parameter COMMAND MODE SELECTION (CMD in C.M) is set to 3 (communication interface input valid). The E3 will then remain stopped until commanded otherwise by the field panel.

Setting 3 does not depend on the COMMAND MODE SELECTION (LAO #34 or CMD in C.M) or FREQUENCY MODE SELECTION (LAO #35 or FREQ in F.F) parameters. Note that the "ERR" (communication interface card error) fault can only be cleared locally at the drive.

Setting 4 will cause the interface board to automatically change the option frequency command (LAO #60) to 400.00Hz upon a timeout occurrence. Note that the drive's actual internal frequency command will be limited by the UPPER LIMIT FREQUENCY parameter (UL in U.F). If the E3 was running at the time of the communications loss, it will then accelerate to and continuously run at the upper limit frequency; otherwise it will remain stopped even though the value of LAO #60 has been modified. Similar to the stop command issued to the E3 by the interface board with setting 2 (see above), the value of LAO #60 will not automatically return to its pre-timeout value once proper network communications are re-established. The field panel must specifically modify the value of LAO #60 once communications are re-established to cause the E3 to run at the desired frequency once again. Note that in order for this setting to actually affect the E3's operating frequency, LAO #35 or parameter FREQUENCY

TOSHIBA

MODE SELECTION (FREQ in Cr.Ut) must be set to 3 (communication interface input valid).

USE EXTREME CAUTION WHEN SELECTING THIS SETTING!

Thoroughly verify that there is no possibility of personal injury or equipment damage due to the drive running at the upper limit frequency setting, especially with the possibly that network communications may not be able to be re-established in a timely fashion (depending on what network condition caused the communications timeout in the first place).

Note that the values of LAO #36 and LAO #37 are non-volatile (stored in the E3's EEPROM). Therefore, do not write to these points more than 10,000 times. In addition, although these values may be changed via the FLN network, the interface board uses the values read upon initialization until the E3 is reset again. Therefore, the E3 must be reset after either of these values has been changed in order for them to take effect and provide the desired operation.

LAO #60 ...Used to set the drive's frequency command (note that the E3 will only use this value as its active frequency command if LAO #35 or parameter FREQ in Cr.Ut is set to 3). Although the adjustment range for this object is 0.00Hz ~ 400.00Hz, the actual frequency command will be internally limited by the values of parameters LL, LL and FH in Cr.F. This point is a RAM-based point; any drive reset causes the value of this point to become 0.00Hz, and the value must be updated by the field panel again for the desired frequency to be attained.

LAO #63 ...Accesses the E3's process (PID) control PROPORTIONAL GAIN parameter (Cr.P in Cr.Fb).

LAO #66 ...Accesses the E3's process (PID) control INTEGRAL GAIN parameter (Cr.I in Cr.Fb).

LAO #67 ...Accesses the E3's PID LOWER LIMIT FREQUENCY parameter (P.LL in Cr.Fb). Note that the adjustment range of this object depends on the setting of MAXIMUM OUTPUT FREQUENCY (FH in Cr.F). The value of MAXIMUM OUTPUT FREQUENCY is read only on drive initialization; therefore, if the setting of MAXIMUM OUTPUT FREQUENCY is changed, be sure to reset the drive to validate the changed setting and provide correct network data limit checking.

LAO #68 ...Accesses the E3's PID DEVIATION UPPER LIMIT parameter (P.U.LL in Cr.Fb).

LAO #69 ...Accesses the E3's PID DEVIATION LOWER LIMIT parameter (P.L.LL in Cr.Fb).

TOSHIBA

8.3.4 Logical Digital Output Points

IMPORTANT: LDO #61 and LDO #70 map directly to E3 configuration parameters (parameters accessible via the E3's keypad). When these parameters are changed (from either the keypad or FLN network), they are stored in the E3's non-volatile EEPROM. The E3's EEPROM has a life span of 10,000 write cycles per parameter; therefore do not write to either of these LDO objects more than 10,000 times. All other LDO points are RAM-based; any drive reset causes the values of these points to become 0, and the values must be updated by the field panel again for the desired drive operation to be achieved.

Note that the actions detailed for LDO #22, LDO #24, LDO #26, LDO #28, LDO #39, LDO #65 and LDO #92 will affect the E3's actual operation only if LAO #34 or parameter $\overline{\text{LDO}}$ in $\overline{\text{C.R.U.E}}$ is set to 3.

LDO #22...Selects forward or reverse run direction.

LDO #24...Run / stop command.

LDO #26...Selects whether the E3 will use acceleration time #1 and deceleration time #1 or acceleration time #2 and deceleration time #2 when accelerating and decelerating. This change can occur dynamically while the drive is running.

LDO #28...Issues a gate block (coast stop) command. This immediately ceases the output of both frequency and voltage to the motor.

LDO #39...Selects whether or not to use compulsory DC injection braking. When using compulsory DC injection braking, the E3 will apply DC injection braking to the motor whenever the output frequency drops below the frequency value set in parameter $\overline{\text{dbF}}$ in $\overline{\text{C.R.P.F}}$. This differs from standard DC injection braking in that with standard DC injection braking, the E3 will apply DC injection braking only when a stop command is given and the output frequency drops below the value set in parameter $\overline{\text{dbF}}$ in $\overline{\text{C.R.P.F}}$.

LDO #61...Activates/deactivates (turns on/off) process (PID) control. Maps to the E3's FEEDBACK CONTROL SELECTION parameter ($\overline{\text{FbP}}$ 1 in $\overline{\text{C.R.Fb}}$). Refer to the discussion regarding LDO #65 for more details.

LDO #65...Enables or disables process (PID) feedback control. Note that this object does not activate (turn on) feedback control; it only enables or disables feedback control once it has already been activated. To activate feedback control, LDO #61 (or parameter $\overline{\text{FbP}}$ 1 in $\overline{\text{C.R.Fb}}$) must be set to 1. Once that has been completed, LDO #65 can be used to disable and enable feedback control dynamically. The reason for this distinction is for those applications that require frequent activation/deactivation of PID control. Since LDO #61 directly maps to the E3's FEEDBACK CONTROL SELECTION parameter, which is stored in the E3's EEPROM, LDO #61 must not be written to more than a total of 10,000 times. In these applications, therefore, LDO #65 can be used to effectively enable and disable PID control. Because the value of LDO #65 is not stored in non-volatile EEPROM, it can safely be written to an unlimited number of times.

LDO #70...Accesses the E3's PID DEVIATION LIMIT SELECTION parameter ($\overline{\text{PUL}}$ in $\overline{\text{C.R.Fb}}$).

LDO #92...Causes the E3 to trip "E" (emergency off).

TOSHIBA

9. Drive Fault Codes

LED Display Message	Fault Code	Explanation
nErrr	0	No error has been recorded since the last drive reset or trip clear
OC1	1	Overcurrent during acceleration
OC2	2	Overcurrent during deceleration
OC3	3	Overcurrent during constant-speed run
OCL	4	Load-end overcurrent detected at start-up (output terminals, motor wiring etc.)
OCR1	5	U-phase IGBT short circuit
OCR2	6	V-phase IGBT short circuit
OCR3	7	W-phase IGBT short circuit
EPH1	8	Lost input phase (option)
EPH0	9	Lost output phase (option)
OP1	10	Overvoltage during acceleration
OP2	11	Overvoltage during deceleration
OP3	12	Overvoltage during constant-speed run
OL In	13	Drive overload
OLMe	14	Motor overload
OLr	15	Dynamic braking resistor overload
OH	16	Drive overheat
E	17	Emergency off
EEP1	18	EEPROM failure during write
EEP2	19	EEPROM failure during initial read
¾	20	Unused
Err2	21	RAM error
Err3	22	ROM error
Err4	23	CPU error
Err5	24	RS232C timer time-out
Err6	25	Gate array error
Err7	26	Output current detection circuit error
Err8	27	Communication interface card error (check that parameter α in α is not 0)
Err9	28	Option ROM error / option ROM not detected
UC	29	Low current
UP1	30	Main circuit undervoltage
¾	31	Unused
OLt	32	Overtorque
EF1	33	Earth fault (software)
EF2	34	Earth fault (hardware)
EFU	35	Open fuse

TOSHIBA

LED Display Message	Fault Code	Explanation
OCr	36	Dynamic braking resistor overcurrent
OC1P	37	Overcurrent in DC section during acceleration
OC2P	38	Overcurrent in DC section during deceleration
OC3P	39	Overcurrent in DC section during constant-speed run
EtE	40	Auto-tuning error
EtYP	41	Drive typeform error
¾	42 ~ 80	Unused
dRNP	81	Closed damper detected
LOSS	82	Loss of IV input detected

TOSHIBA

TOSHIBA INTERNATIONAL CORPORATION

INDUSTRIAL DIVISION

13131 West Little York Rd., Houston, TX 77041

Tel: [800] 231-1412 / [713] 466-0277 Fax: [713] 466-8773

World Wide Web <http://www.tic.toshiba.com>

Printed in U.S.A



INDUSTRIAL CONTROL COMMUNICATIONS