

## A. Mitsubishi FX Series

Configuration of the RS-422 connection is shown in the following Figure 1 .

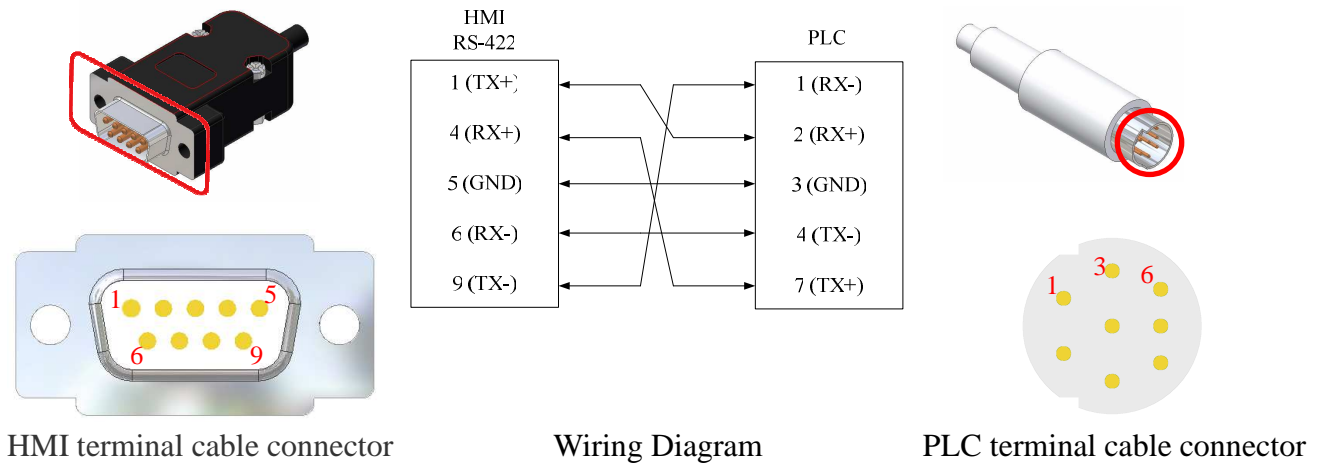

Fig. 1 RS-422 Communications Wiring

Configuration of the RS-232 and FX2 connection is shown in the following Figure 2 .

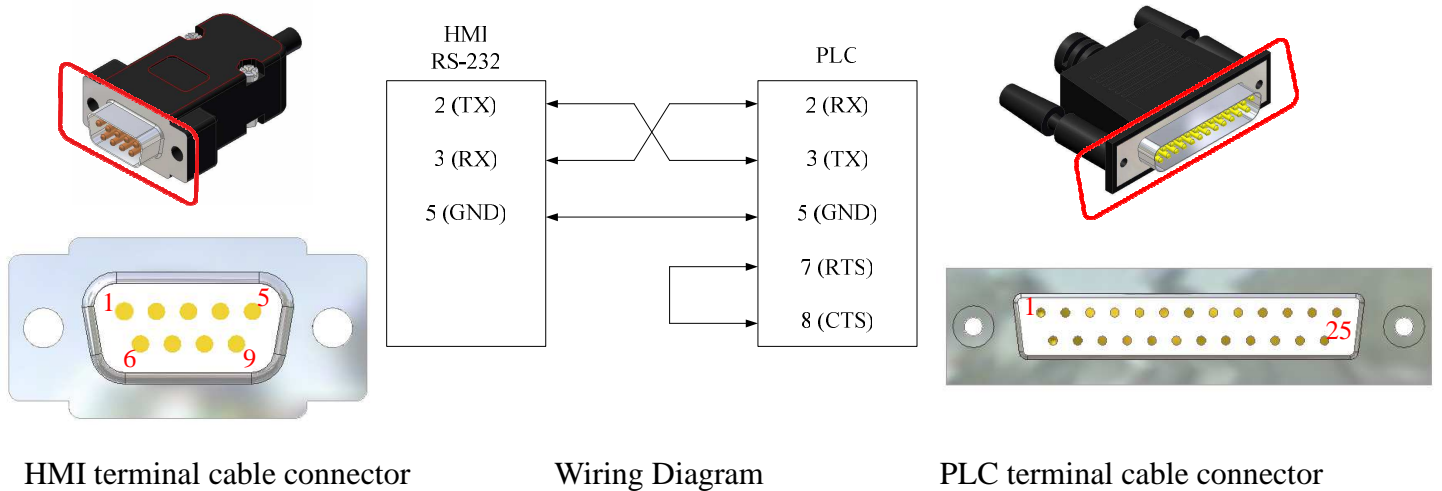

Fig. 2 FX2 Connection



- Use the AX-232AW-S data transfer cable for the connection.

## B. Mitsubishi FX Series – Computer Link

When the Mitsubishi FX Series is connected with an external 232-BD module, wire the RS-232 connection as shown in Figure 3.

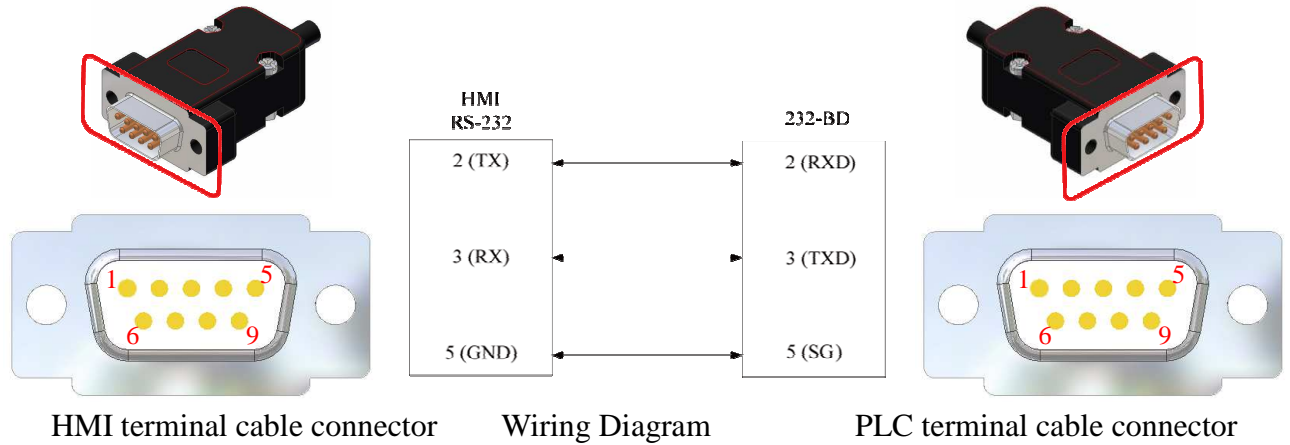

Fig. 3 RS-232 Communications Wiring



The following table 4 lists the FX series external 232-BD module serial setting example, the actual set still mainly user needs.

Table 4 Lists of 232-BD module serial setting

BD module serial setting	Baud Rate(Bps)	Parity	Data Length	Stop Bit	CR/LF Select	PLC D8120 Device
232-BD(Type1)	9600	Even	7	1	None	E886(HEX)
232-BD(Type4)					CR&LF	6886(HEX)

When the Mitsubishi FX Series is connected with an external 422-BD module, wire the RS-422 connection as shown in Figure 5 .

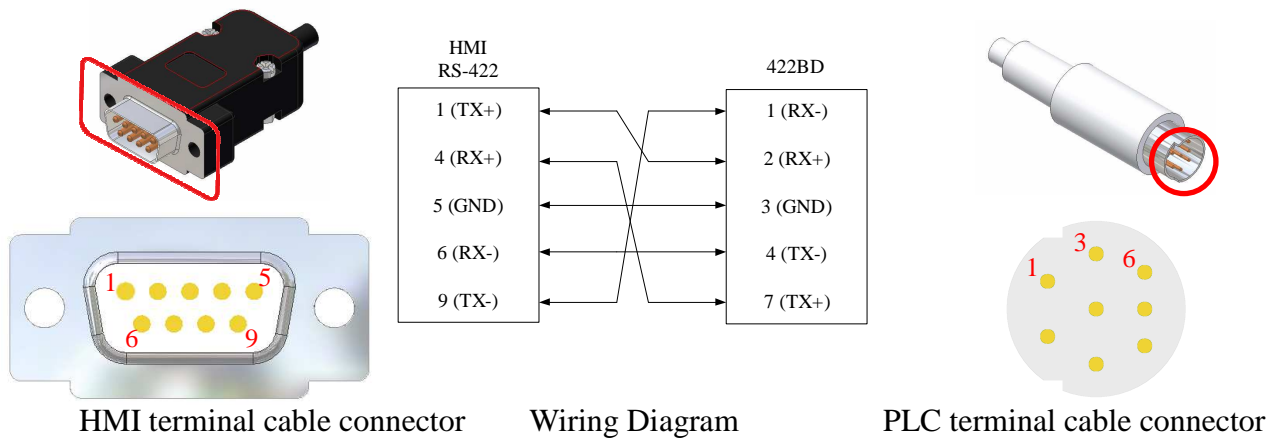

Fig. 5 RS-422 Communications Wiring

When the Mitsubishi FX Series is connected with an external 485-BD module, wire the RS-485 connection as shown in Figure 6 .

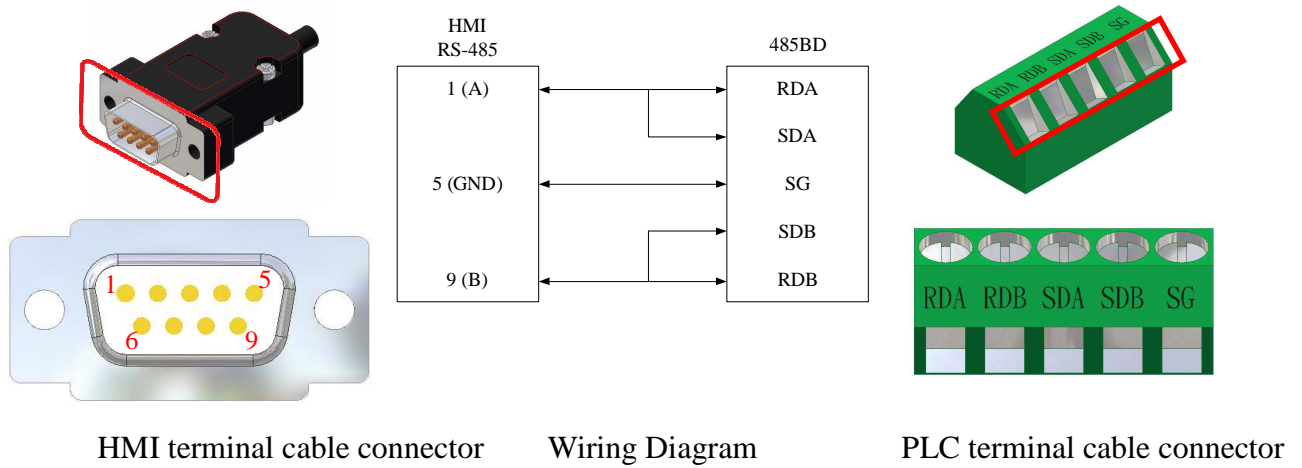

Fig. 6 RS-485 Communications Wiring

### c. Mitsubishi Q Series

Configuration for the RS-232 connection is shown in the following Figure 7 .

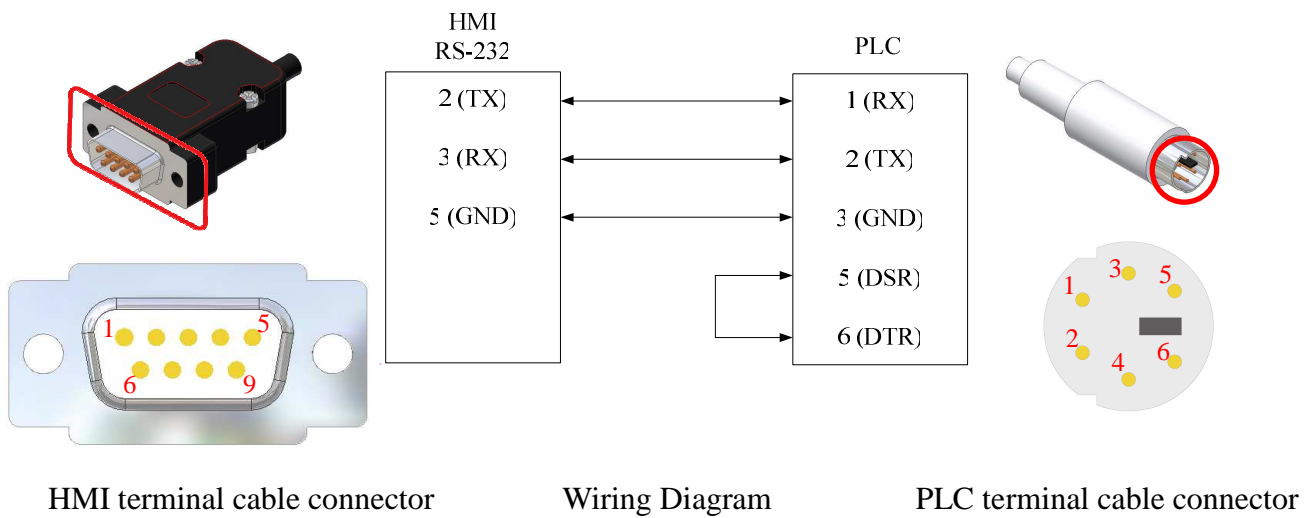

Fig. 7 Q Series Connection



- Setting of the PLC software serial parameters: configure to use serial communication, select the transmission speed, and set RUN to write mode, as shown in Figure 8 .

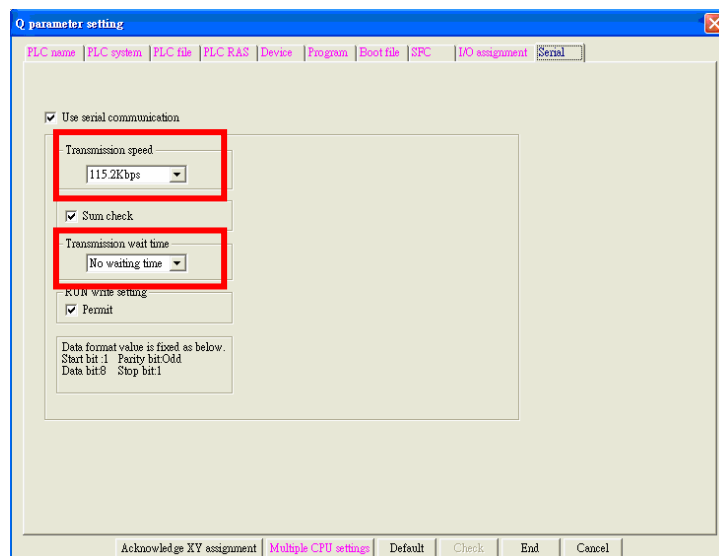

Fig. 8 Setting Parameters

#### d. Mitsubishi Q Series – Computer Link

When the Mitsubishi Q Series is connected with an external QJ71C24 expansion module, wire the RS-232 connection as shown in Figure 9 .

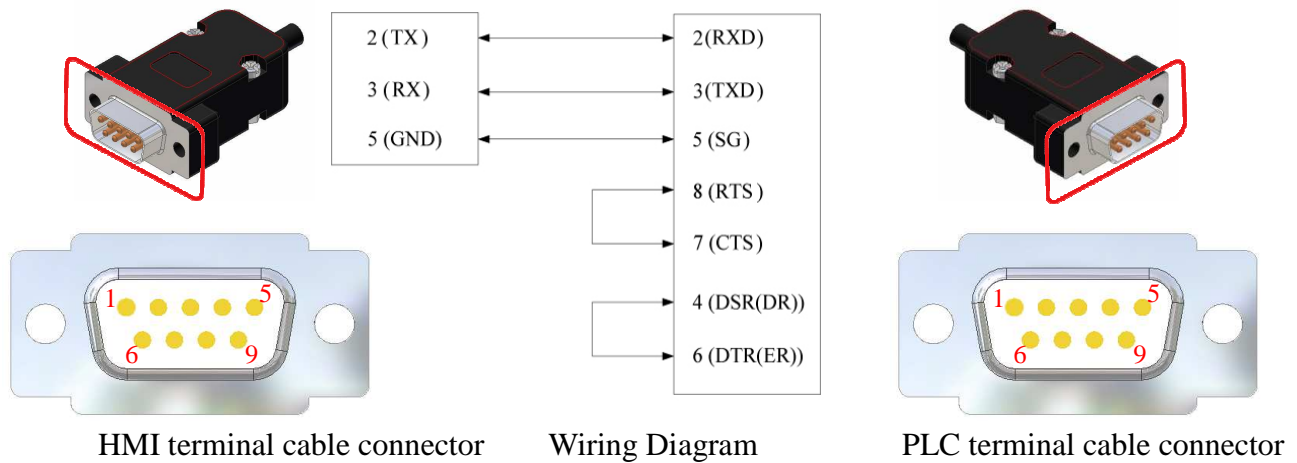

Fig. 9 RS-232 Communications Wiring

Configuration of the RS-422 connection is shown in Figure 10 .

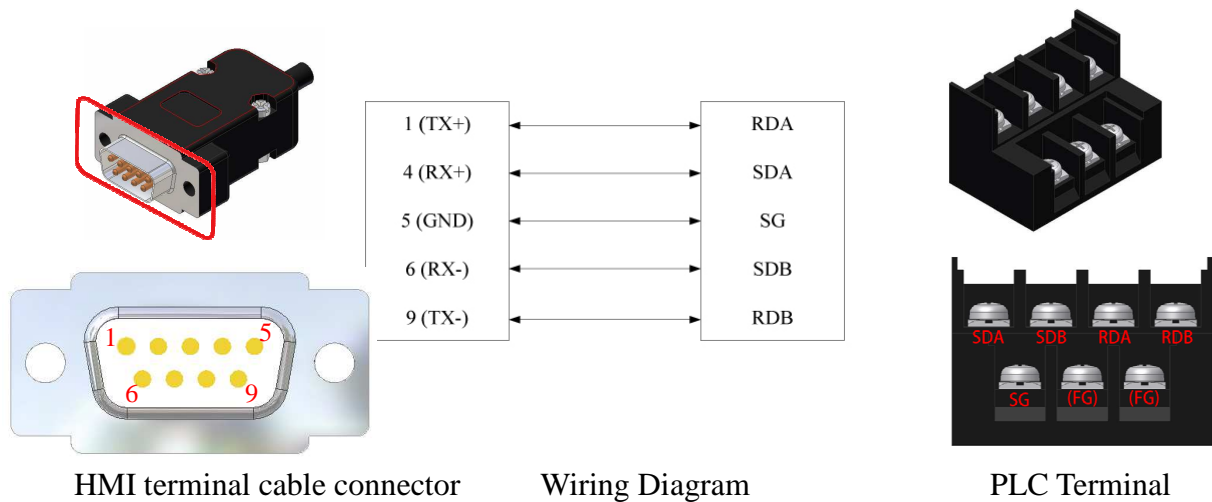
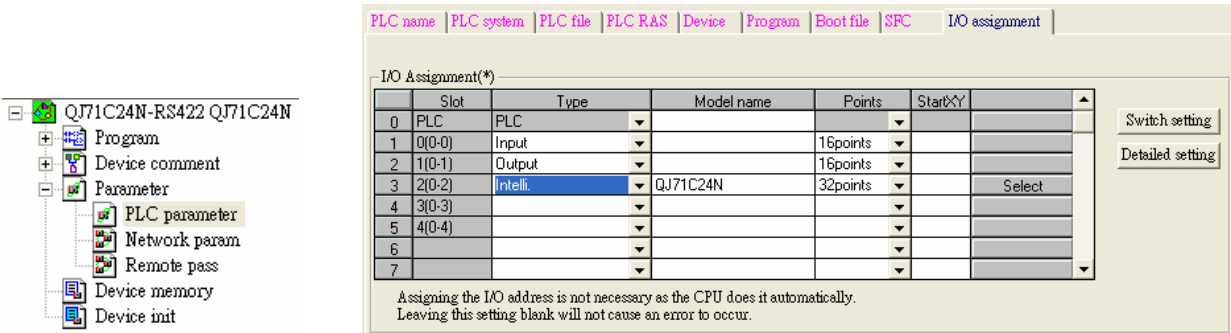

Fig. 10 RS-422 Communications Wiring

To configure the communication settings for the Mitsubishi Q serie to be connected with an external QJ71C24 expansion module, execute the GX Developer software, and follow the steps shown below.

**Step 1 :** Select the PLC parameters, and set the expansion model in the configuration column, then click the “Select” button to start the communication setting.



**Step 2 :** After the model is selected, set up the communication configuration.

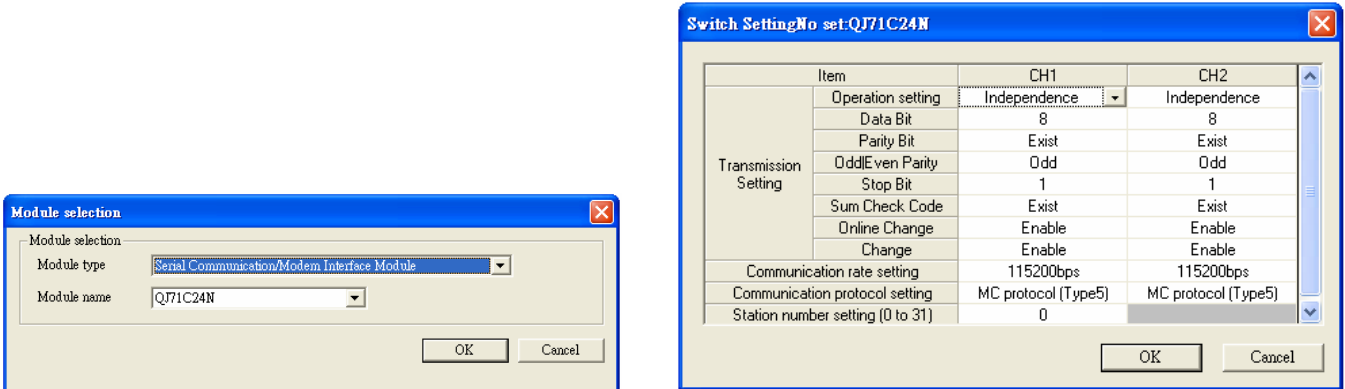

Communication Setting	Baud rate (Bps)	Parity	Data bits	Stop bit	Protocol
CH1(RS-232)	115200	Odd	8	1	MC protocol (Type5)
CH2(RS-422)					



- For configuration details of the Mitsubishi Q Series expansion module, please refer to Mitsubishi PLC manual.

### e. Mitsubishi QnA Series

Configuration for the RS-232 connection is shown in Figure 11.

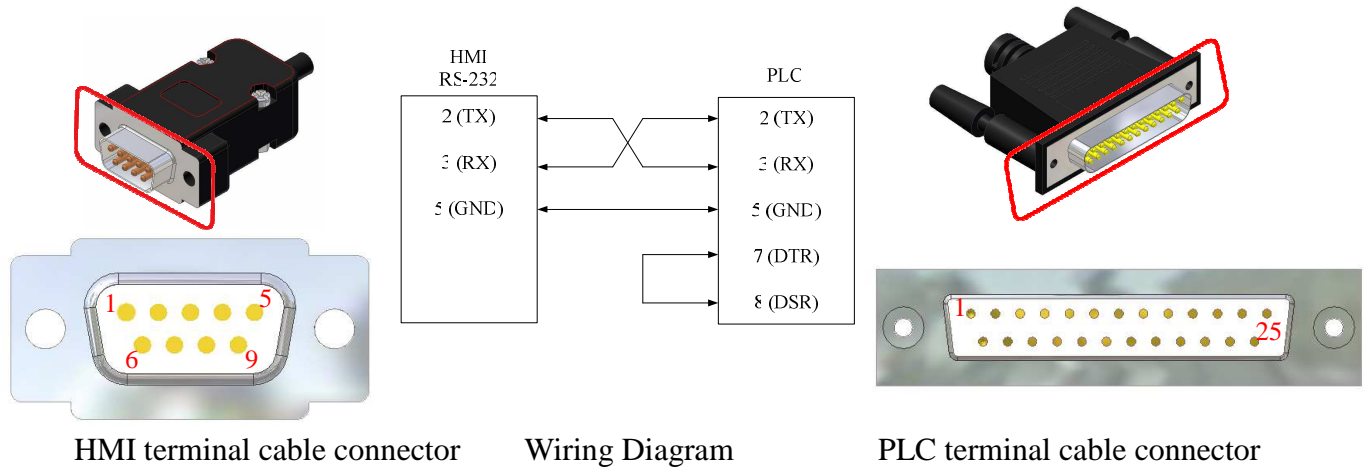

Fig. 11 QnA Series Connection



- Use AX-232AW-S data transmission cable to connect.

## f. Mitsubishi A Series

Configuration for the RS-232 connection is shown in Figure 12.

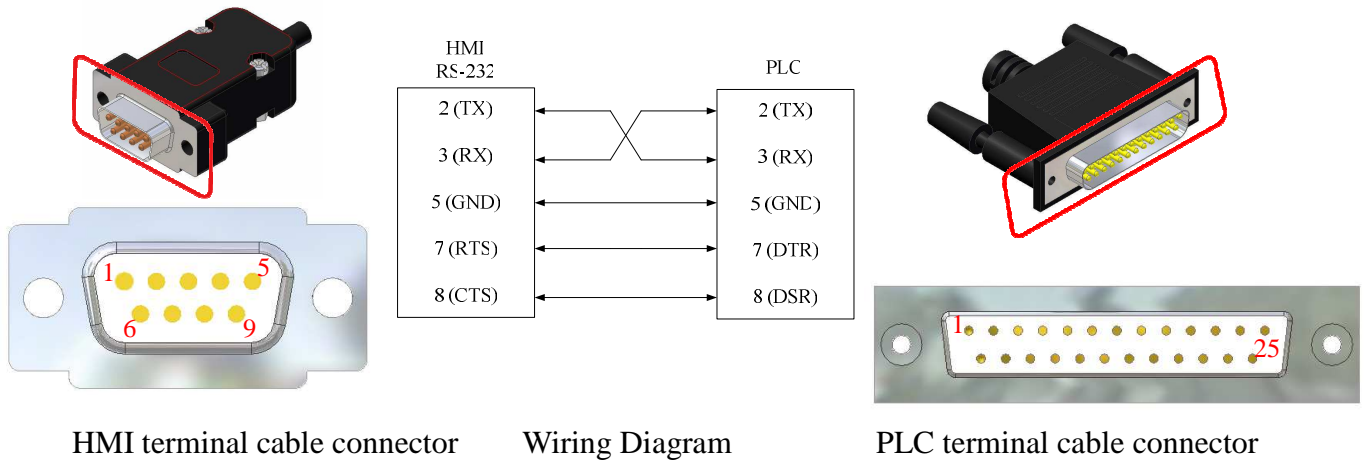

Fig. 12 A Series Connection



- Use AX-232AW-S data transmission cable for the connection.



### g. Mitsubishi A Series – Computer Link

When the Mitsubishi A Series is connected with an A1SJ71UC24-R2 expansion module, wire the RS-232 connection as shown in Figure 13.

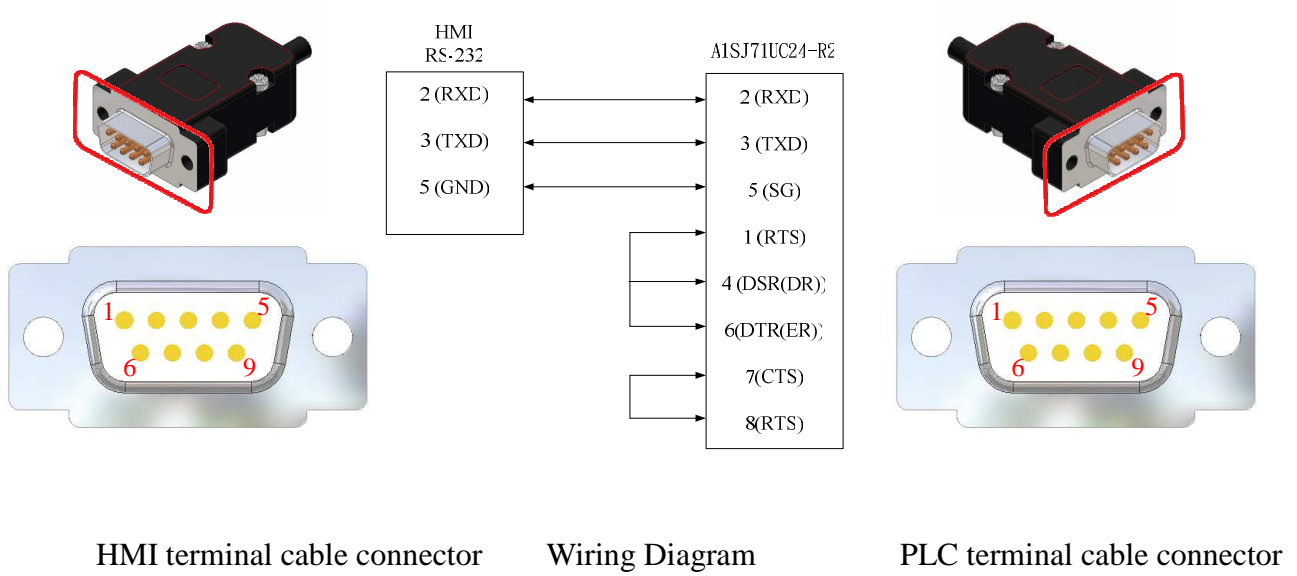

Fig. 13 Connection with A1SJ71UC24-R2 expansion module

Serial setup :

Type	Baud Rate (Bps)	Parity	Data Length (Bit)	Stop Bit (Bit)	PLC Station NO.
<b>FX Series</b>	9600	Even	7	1	N/A
<b>A Series</b>	9600	Odd	8		
<b>Q Series</b>	19200 38400 57600 115200				
	<b>QnA Series</b>				