

M90-19-R5

RS232 to RS422/RS485 Isolated Universal Converter

1. Introduction

The M90-19-R5 converts serial data from the RS232 standard to either RS422 or RS485.

Features:

- Universal converter—can be used with both Unitronics' and other manufacturer's devices.
- No 'handshake' required—automatically senses the direction of the data flow, and switches the transmission direction.
- Standard-sized housing, snap-mounts onto a 35mm DIN rail.
- Screw terminal block connections provided.
- RJ11 connector provides easy plug-in connection for Unitronics (and other) RS232-based devices.
- Supports networks containing up to 32 nodes.
- Either full or half-duplex communications.
- Stand-alone power supply.
- LED indicators.



2. Function diagram

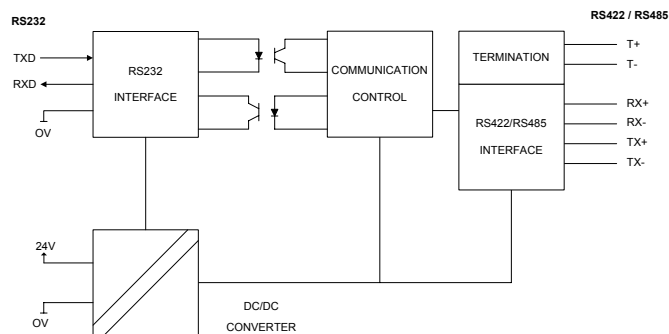

3. Wiring Connections

Before making your connections, please read the wiring considerations on the next page.

Top Connectors

Power supply terminals

Rear connector

24V	Supply voltage
0V	Reference supply voltage
Earth	Earth

RS232 terminals

Front connector

TXD	RS232 transmit signal
RXD	RS232 receive signal
0V	RS232 0V reference

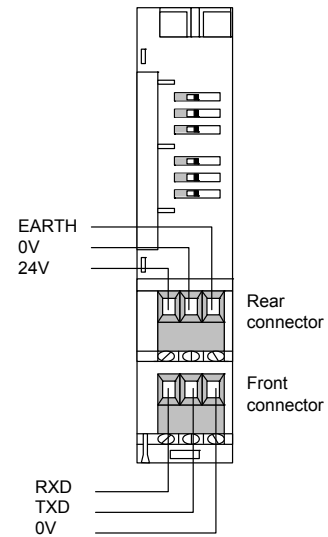

Bottom Connectors

RS422/RS485 terminals

Rear connector

TX-	RS422/RS485 negative transmit signal
RX-	RS422/RS485 negative receive signal
T-	Negative termination

Front connector

TX+	RS422/RS485 positive transmit signal
RX+	RS422/RS485 positive receive signal
T+	Positive termination

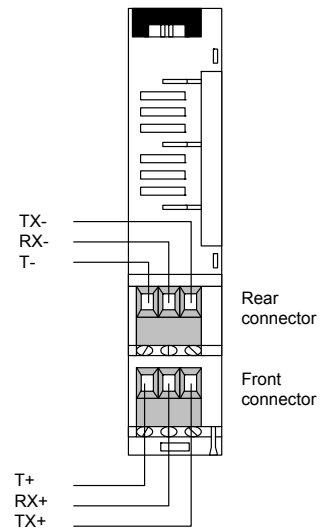

RJ11 Pin-out

RS232 terminal

<u>Pin Number</u>	<u>Function</u>
1	Not connected
2	0V reference
3	TxD signal
4	RxD signal
5	0V reference
6	Not connected

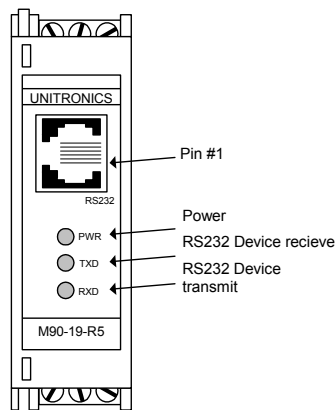

RS232 wiring considerations

- Since the RJ11 connector and the screw block terminal both use the same signal source, only one can be used for establishing RS232 communications. Connect the screw block terminal as follows:

<u>M90-19-R5</u>	<u>Device</u>
RxD	<----- TxD
TxD	-----> RxD
0V	----- 0V

- Adapters and cables configured for the RJ11 connector are available by separate order as listed in RS232 Accessories, on page 8.

RS485/422 wiring considerations

- Use shielded, twisted pair cables.
- Configure the network as a multidrop bus network.
- Minimize the stub (drop) length leading from each device to the bus. Ideally, the main cable should be run in and out of the networked device.
- Do not cross positive (A) and negative (B) signals. Positive terminals must be wired to positive, and negative terminals to negative.
- You must create network termination points by using the two end point devices integrated into your network. Connect the T- terminal to Rx-, and T+ to RX+ in each end point device as shown in Figure 1 and Figure 2.
- To support RS485, connect the Tx+ terminal to the Rx+, and the Rx- terminal to the Tx-, as shown in Figure 1 on page 4.

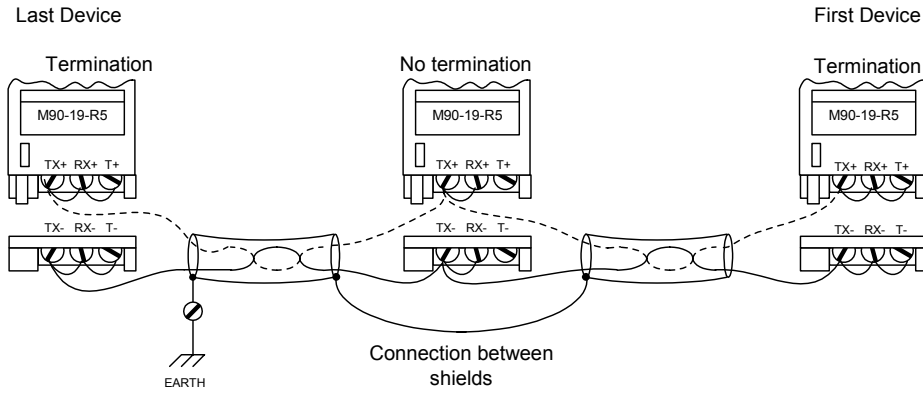

Figure 1 RS485 Terminal Wiring

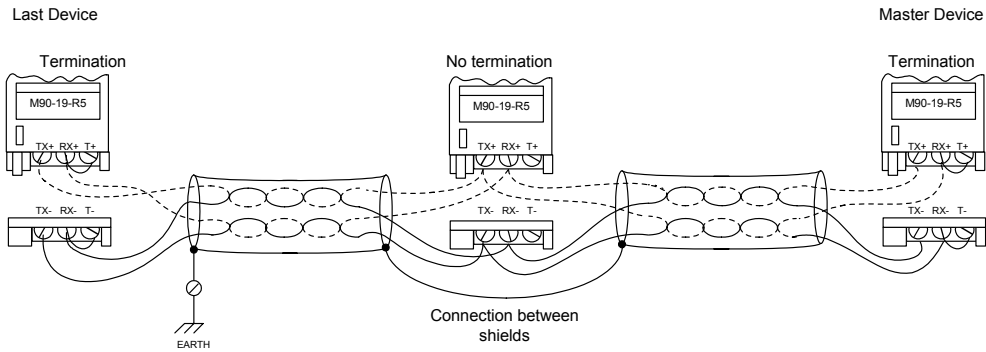

Figure 2 R422 Terminal Wiring

4. DIP Switch Settings

The DIP switches are located on the top of the device. They control data format, transmission speed, and whether communications are half or full duplex.

Data can be transmitted in either 10 or 11 bit format. Each format includes a start and stop bit.

The DIP switches are pictured below. Note that a lowered switch is 'on', a raised switch is 'off'.

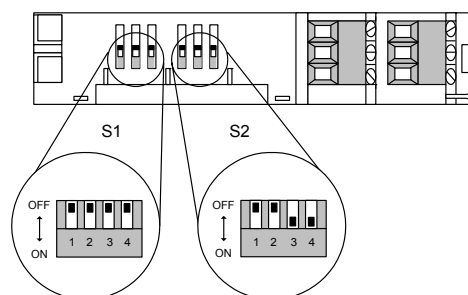

The table below shows the DIP switch setting options; note that ‘-’ is off.

		S1				S2			
		1	2	3	4	1	2	3	4
10 bit	2400	-	-	-	-	-	-	ON	
	4800	-	-	-	-	-	ON	-	
	9600	-	-	-	-	ON	-	-	
11 bit	2400	ON	-	ON	ON	-	-	ON	
	4800	-	ON	ON	-	-	ON	-	
	9600	ON	ON	-	-	ON	-	-	
Half Duplex									ON
Full Duplex									-

Note that RS485 requires a half duplex setting; RS422 can function using either half or full duplex setting.

The factory default settings, shown below, enable 10 bit communications. 10 bits might, for example, comprise one start bit, seven data bits, a parity bit, and a stop bit; half duplex, at 2400 bps. These settings suit the M90 PLC.

S1				S2			
1	2	3	4	5	6	7	8
-	-	-	-	-	-	ON	ON

5. Examples

The M90 PLC is used in both of the examples given below; the DIP switch settings used are therefore the factory default settings

Example 1

The M90-19-R5 converter serves as the RS232-to-RS485 communications interface between a Unitronics M90 controller and a P608 model PLC.

The cable used to connect the M90 to the M90-19-R5 converter is a convenient, plug-in RJ11 connector cable, which is available by separate order.

The P608 is connected to the M90-19-R5 via RS485 communication cable. One end of the cable is connected to the M90-19-R5 screw terminal block. The other end is connected, via a 9-pin D-type connector, to the RS485 communication channel of the P608.

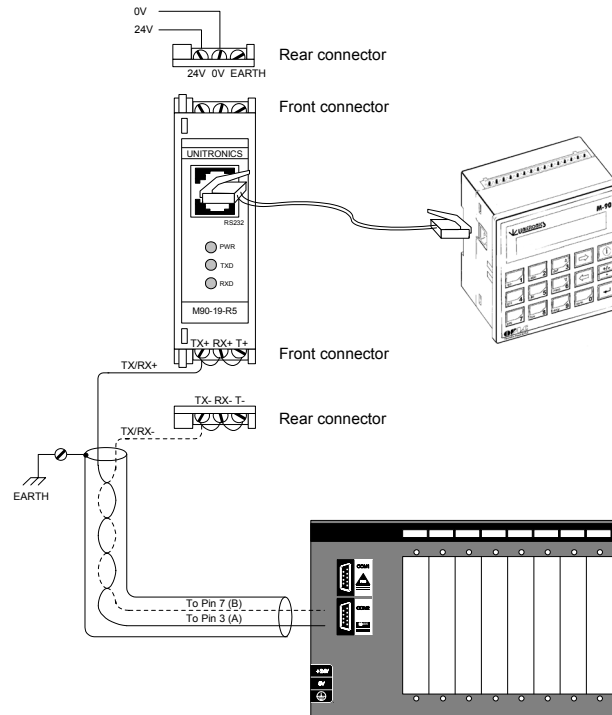

Example 1

Termination points:

- P608: the termination switch is switched ON.
- M90-19-R5: the T+ and T- terminals are interconnected as shown above, creating termination points.

Example 2

RS485 supports a network comprising 2 M90 controllers and a PC; the M90-19-R5 provides the communications interface.

In order to prevent interference in this type of configuration, we strongly recommend that the 24V power supply of the computer-connected M90-19-R5 be separate from the power supply of the other two converters.

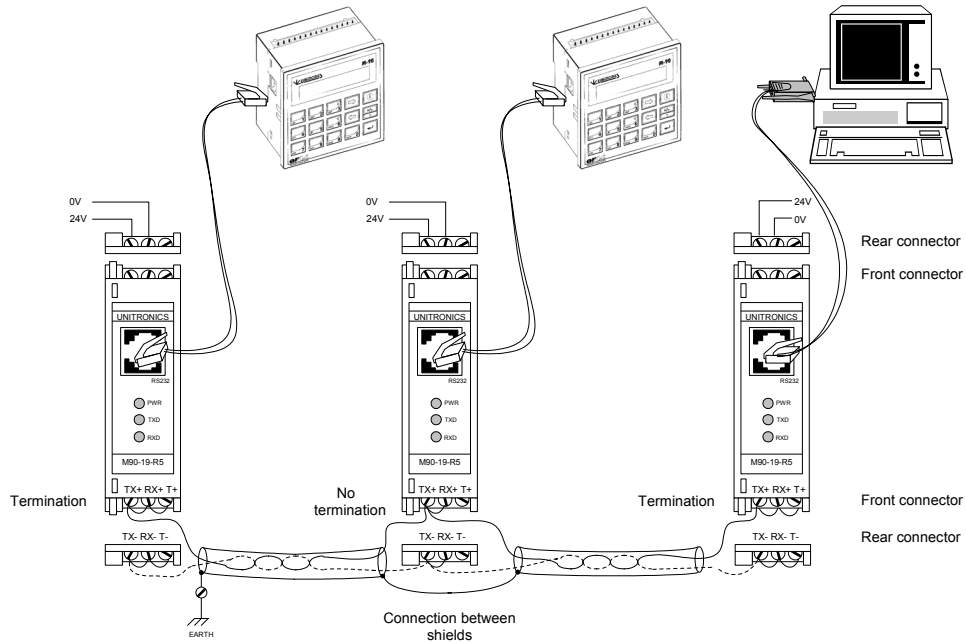

Example 2

Termination points:

- The T+ and T- termination points of the two end point devices are interconnected; those of the middle device are not.

Unitronics' RJ11 connector cables and 9-pin serial port adapter provide a convenient way to connect a PC or any other device to your network via the RS232 serial port. These items are listed under Accessories on page 8, and are available by separate order.

RS232 connections can also be made using the M90-19-R5's screw block terminal connectors.

6. Specifications

Power Supply

Input voltage	24VDC
Permissible range	20.4 to 28.8 VDC
Maximum input current	35mA @ 24VDC

RS232

Input voltage	±20VDC maximum
Cable length	15m maximum (50 feet)
Interface connectors	Either RJ11, or screw-type 2.5mm ² terminal

RS422/RS485

Input voltage	-7 to +12V differential maximum
Cable type	Shielded twisted pair, in compliance with EIA RS485
Cable length	1200m maximum (4000 feet)
Interface connector	Screw-type 2.5mm ² terminal

General

Isolation	yes
Size (L x W x H)	110.8 x 22.5 x 75 mm (4.38"x 0.89"x 2.96")
Weight	98g (3.44 oz)
Communication status indicators	Yes (see illustration in Section 3)
Baud rates	2400, 4800, 9600 bps
Mounting	Snap-mounts onto 35mm DIN rail (EN50022-35)
Flame-resistant	UL94-VO

Environmental

Storage temperature	-20 to 70°C
Operating temperature	0 to 50°C
Storage humidity	10 to 95% relative humidity
Operating humidity	30 to 90% relative humidity

7. RS232 Accessories

MJ10-22-CS30	2m cable with RJ11 terminators
MJ10-22-CS31	30cm cable with RJ11 terminators
MJ10-22-CS25	D-type 9-pin RJ11-serial port adapter

8. Mechanical Dimensions

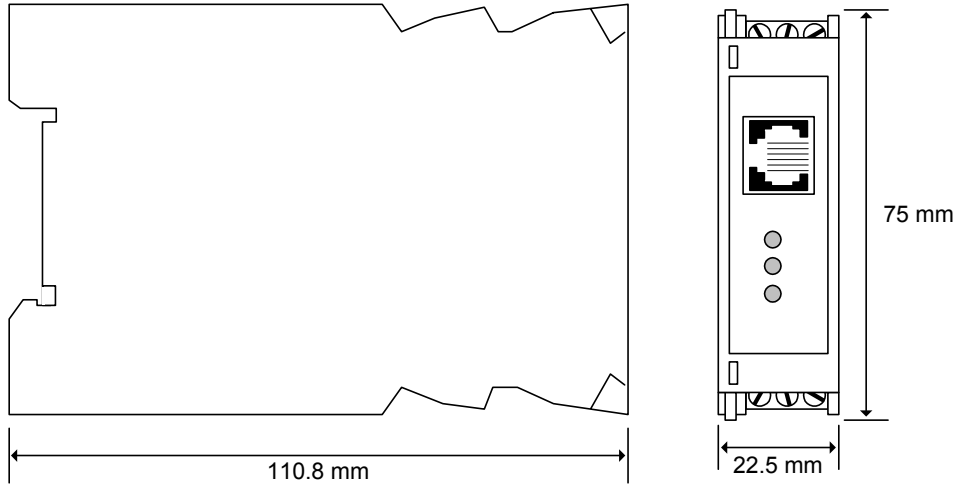

This page is intentionally left blank