

# HE-IO34-100

## Specification Sheet

This guide provides basic information for Unitronics HE-IO34-100 I/O connection kit of V570-57-T34 Vision OPLC.

### General Description

The Unitronics HE-IO34-100 kit together with the V570-57-T34 offers the following extended I/Os:

- 16 Digital Inputs
- 2 Analog Inputs
- 16 Transistor Outputs

Check the V570-57-T34 technical specifications for additional information.



### Standard Kit Contents

HE-IO34 HE-10 connector unit, with screw terminal blocks, DIN mounted.

HE1-CA100 (x2) 20-wire ribbon cable, length 1 meter, ended by HE-10 sockets.

### Danger Symbols

When any of the following symbols appear, read the associated information carefully.

Symbol	Meaning	Description
	Danger	The identified danger causes physical and property damage.
	Warning	The identified danger could cause physical and property damage.
<i>Caution</i>	Caution	Use caution.

---

- Before using this product, the user must read and understand this document.
- All examples and diagrams are intended to aid understanding, and do not guarantee operation. Unitronics accepts no responsibility for actual use of this product based on these examples.
- Please dispose of this product according to local and national standards and regulations.
- Only qualified service personnel should open this device or carry out repairs.

---



 Failure to comply with appropriate safety guidelines can cause severe injury or property damage.

---



- Do not attempt to use this device with parameters that exceed permissible levels.
- To avoid damaging the system, do not connect/disconnect the device when power is on.

### Environmental Considerations

-  Do not install in areas with: excessive or conductive dust, corrosive or flammable gas, moisture or rain, excessive heat, regular impact shocks or excessive vibration, in accordance with the standards given in the product's technical specification sheet.
- Ventilation: 10mm space required between controller's top/bottom edges & enclosure walls.
-  Do not place in water or let water leak onto the unit.
- Do not allow debris to fall inside the unit during installation.
- Install at maximum distance from high-voltage cables and power equipment.

**Mounting**

**Dimensions**

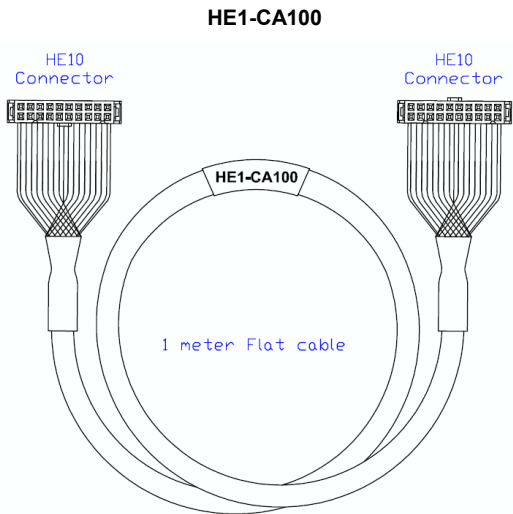
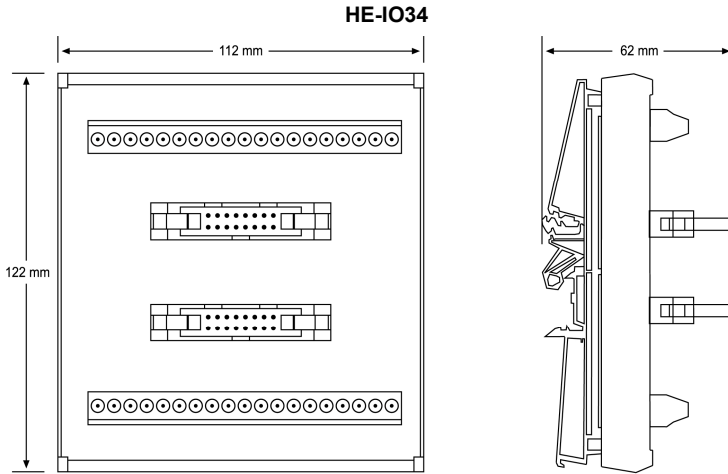

**DIN-rail mounting**

Snap the HE-IO34-100 onto the DIN rail as shown below; the device will be squarely situated on the DIN rail as shown below.

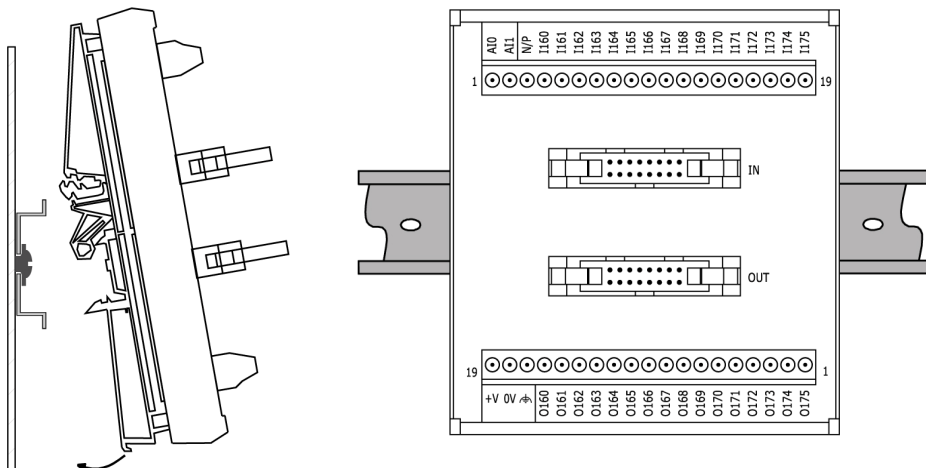

**HE-IO34 Connecting to V570-57-T34**

V570-57-T34 is connected to the HE-IO34-100 as shown below, via two HE1-CA100 cables. The cables provided with the HE-IO34-100 kit are one meter long; cables of other lengths are available by separate order.

To avoid damaging the system, do not connect or disconnect the device when the power is on.

HE-IO34

V570-57-T34

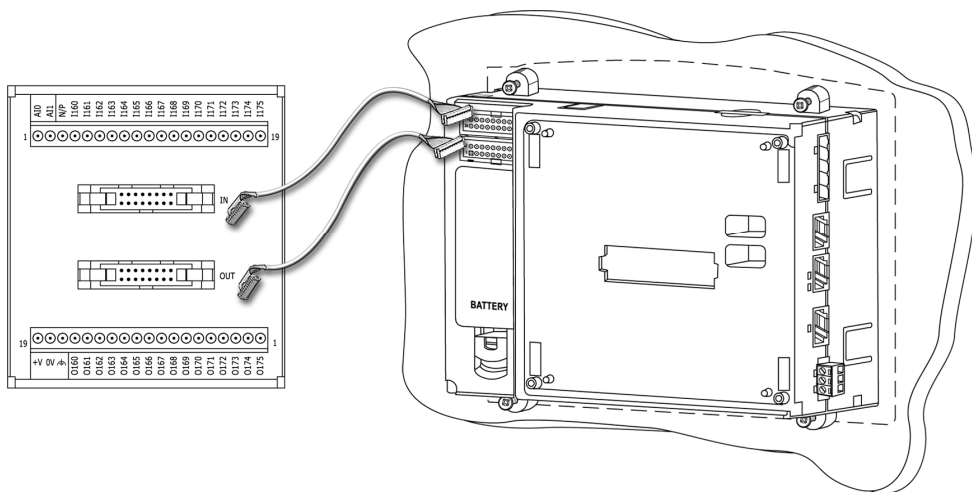

## Wiring



- Do not touch live wires.



- Install an external circuit breaker. Guard against short-circuiting in external wiring.
- Use appropriate circuit protection devices.
- Unused pins should not be connected. Ignoring this directive may damage the device.
- Double-check all wiring before turning on the power supply.

### Caution

- To avoid damaging the wire, do not exceed a maximum torque of 0.5 N·m (5 kgf·cm).
- Do not use tin, solder, or any substance on stripped wire that might cause the wire strand to break.
- Install at maximum distance from high-voltage cables and power equipment.

## Wiring Procedure

Use crimp terminals for wiring; use 26-12 AWG wire (0.13 mm<sup>2</sup>–3.31 mm<sup>2</sup>).

- Strip the wire to a length of 7±0.5mm (0.250–0.300 inches).
  - Unscrew the terminal to its widest position before inserting a wire.
  - Insert the wire completely into the terminal to ensure a proper connection.
  - Tighten enough to keep the wire from pulling free.
    - Input or output cables should not be run through the same multi-core cable or share the same wire.
- Allow for voltage drop and noise interference with input lines used over an extended distance. Use wire that is properly sized for the load.

## I/Os

This model comprises a total of 16 digital inputs, 2 analog inputs and 16 outputs.

- Input functionality can be adapted as follows:

- All 16 inputs may be used as digital inputs. All 16 may be wired in a group, via a pin on the connector, as either npn or pnp. In addition, according to jumper settings and appropriate wiring:
- Inputs 160 & 162 can function as either a high-speed counter, as part of a shaft-encoder, or as a normal digital input
  - Inputs 161 & 163 can function as either a counter reset, as part of a shaft-encoder, or as a normal digital input
  - If inputs 160 & 162 is set as a high-speed counter (without reset), inputs 161 & 163 can function as normal digital inputs

- Output functionality is as follows:

- All 15 (161-175) outputs are pnp outputs
- Output 160 is an npn - High Speed Output



- Incompatible wiring connections may seriously damage the controller

**I/O Wiring**

**npn (sink) Input Wiring**

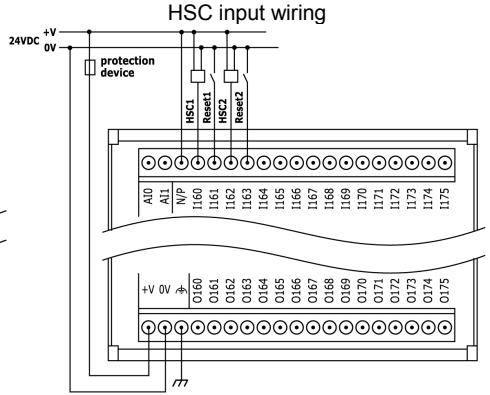
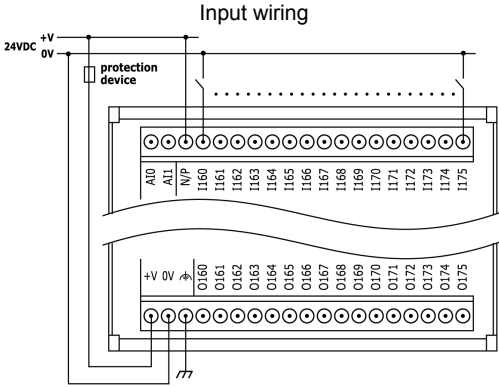

**pnp (source) Input Wiring**

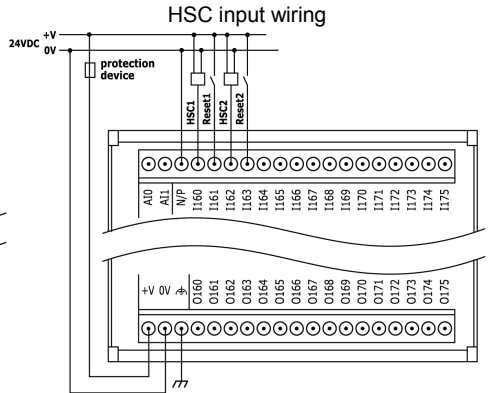
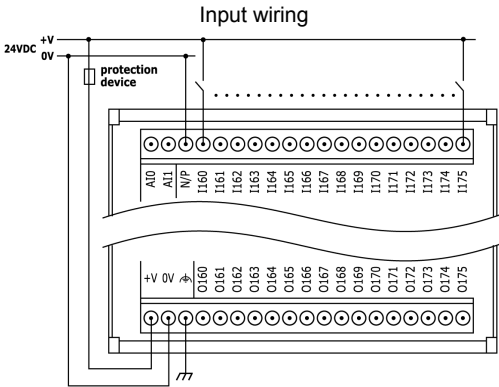

**Shaft-encoder Wiring**

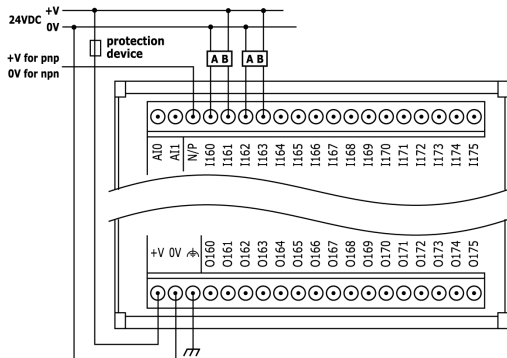

### Analog Input Wiring

Analog input wiring, current (2 wire)

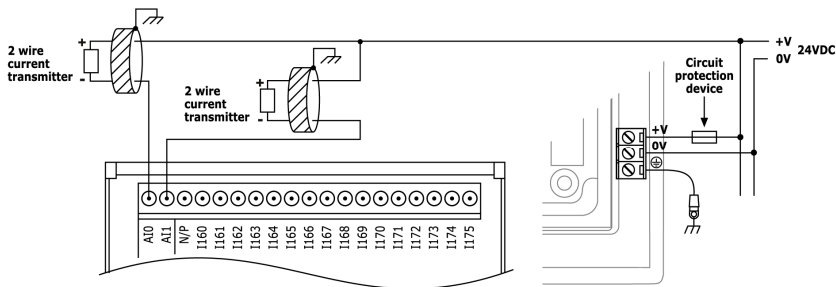

Analog input wiring, current (4-wire)

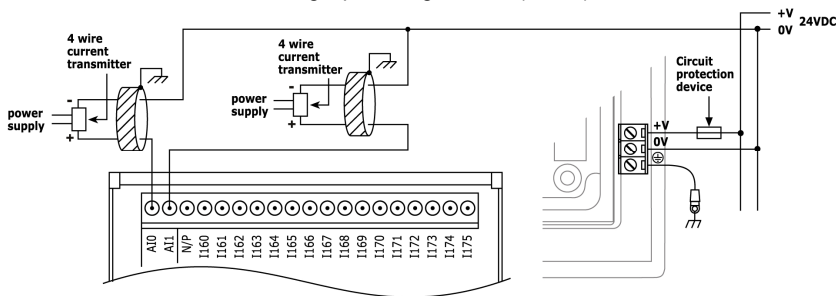

- Shields should be connected at the signal's source.
- Analog inputs are not isolated and they are relative to main Controller Power Supply.

### Output Wiring

Transistor Outputs (pnp)

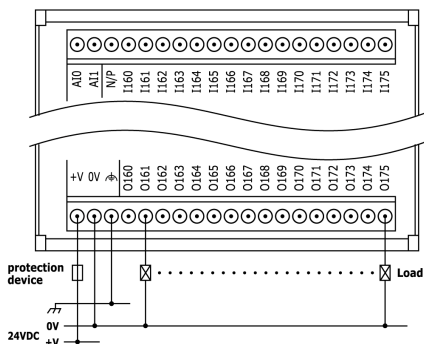

Transistor High Speed Output (npn)

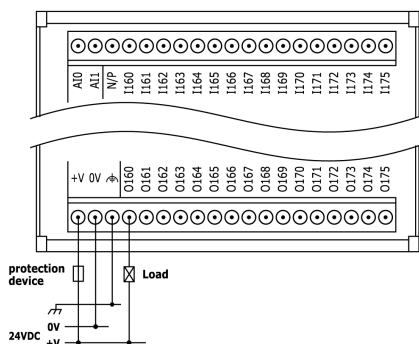

## Power Supply

Digital I/O requires an external 24VDC power supply.



- A non-isolated power supply can be used if a 0V signal is connected to the chassis.



- Install an external circuit breaker. Guard against short-circuiting in external wiring.
- Double-check all wiring before turning on the power supply.
- Do not connect either the 'Neutral' or 'Line' signal of the 110/220VAC to device's 0V pin.
- In the event of voltage fluctuations or non-conformity to voltage power supply specifications, connect the device to a regulated power supply.

## Earthing the Power Supply

To maximize system performance, avoid electromagnetic interference by:

- Mounting the controller on a metal panel.
- Earthing the controller's power supply: connect one end of a 14 AWG wire to the chassis signal; connect the other end to the panel.

**Note: If possible, the wire used to earth the power supply should not exceed 10 cm in length. However, it is recommended to earth the controller in all cases.**

The information in this document reflects products at the date of printing. Unitronics reserves the right, subject to all applicable laws, at any time, at its sole discretion, and without notice, to discontinue or change the features, designs, materials and other specifications of its products, and to either permanently or temporarily withdraw any of the foregoing from the market.

All information in this document is provided "as is" without warranty of any kind, either expressed or implied, including but not limited to any implied warranties of merchantability, fitness for a particular purpose, or non-infringement. Unitronics assumes no responsibility for errors or omissions in the information presented in this document. In no event shall Unitronics be liable for any special, incidental, indirect or consequential damages of any kind, or any damages whatsoever arising out of or in connection with the use or performance of this information.

The tradenames, trademarks, logos and service marks presented in this document, including their design, are the property of Unitronics (1989) (R"G) Ltd. or other third parties and you are not permitted to use them without the prior written consent of Unitronics or such third party as may own them.

DSP-V570-HEIO34 05/09