

# EX-D16A3-RO8

## XL I/O Expansion Module (Built-in Adapter) Installation Guide

The Unitronics® EX-D16A3-RO8 is an XL I/O expansion module for use in conjunction with specific Unitronics controllers. XL modules comprise enhanced I/O configurations and detachable I/O connectors. In addition, this module comprises a built-in adapter for communicating with the PLC and providing power to the other expansion modules in the system.

This module provides:

- 16 digital inputs, including 2 HSC
- 3 analog inputs
- 8 relay outputs

For additional information and technical specifications, visit the Technical Library at [www.unitronics.com](http://www.unitronics.com).

### Component Identification

1	Power supply connector
2	Status indicators
3	Output connector
4	Output power supply connection points
5	PLC expansion port (for communication with the PLC)
6	Input/output status indicators
7	Module-to-module connector port
8	Input connectors

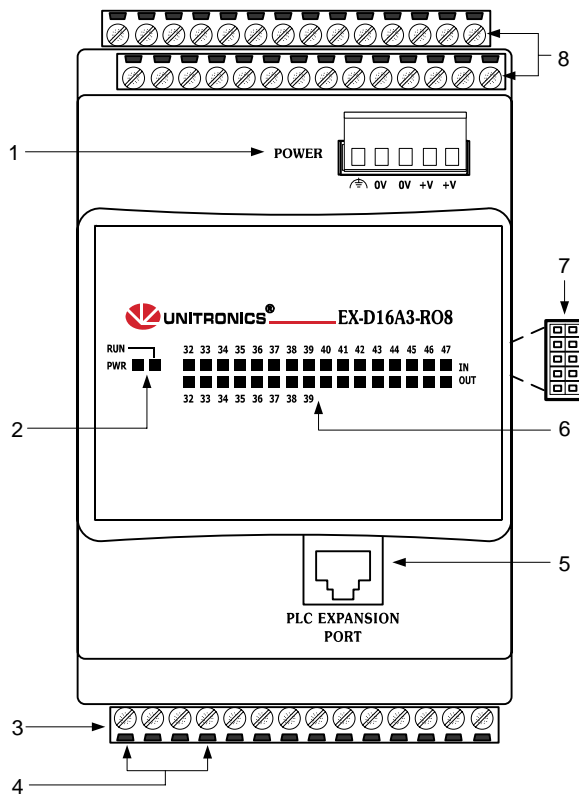

Failure to comply with appropriate safety guidelines can cause severe personal injury or damage to property.

- Only qualified personnel should service and operate this device.
- When power is turned on, do not connect or disconnect the device to avoid damaging the system.

### Mounting the Module

To mount the module on a 35mm DIN-rail, snap it squarely onto the DIN-rail, as shown below.

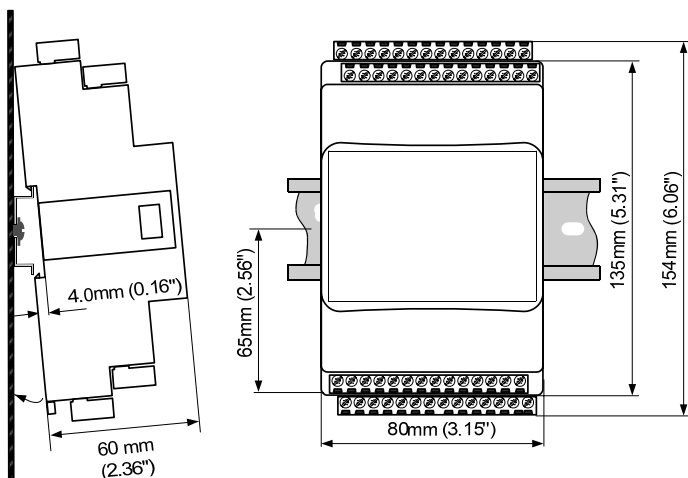

- Install the module in an upright position.
- To ensure good ventilation, leave at least 50mm between the device and all other objects above or below it.
- Install at a maximum distance from high-voltage cables and power equipment.

### Connecting Modules

To connect a module to the adapter or expansion module:

1. Push the module-to-module connector (1) into the port (2) located on the right side of the module or adapter.
2. Push the protective cap (3) into the connector port of the last module. The cap is supplied with the adapter.

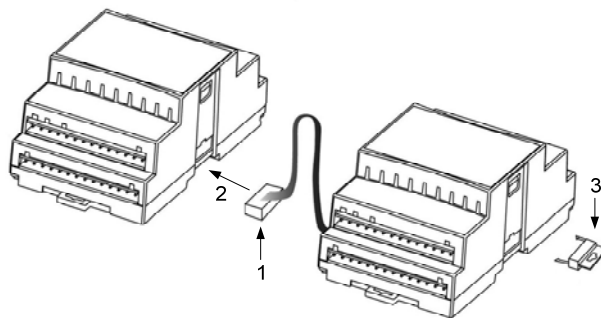

## Connecting the Module to the PLC

Use the communication cable to connect the module's PLC expansion port to the PLC.

Take care to connect the correct cable. The connectors of this cable are housed in yellow insulation. Note that one end is marked To PLC and the other To Adapter; insert accordingly.

The module is supplied with a 1-meter cable, part number EXL-CAB100. Other cable lengths are also available.

Use only an original Unitronics cable and do not make any changes to it.

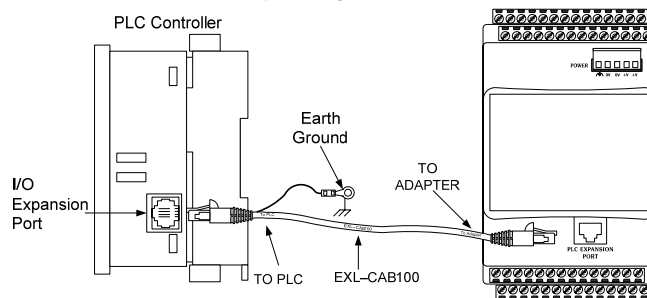

## Wiring Considerations

- Use crimp terminals for wiring and use 26-12 AWG wire (0.13mm<sup>2</sup>–3.31mm<sup>2</sup>).
- Strip the wire to a length of 7±0.5mm (0.250–0.300”).
- Do not route input cables together with output cables through the same multi-core cable or wire.
- Use wire that is correctly sized for the load. Allow for voltage drop and noise interference with extended input lines.

**Note:** Connect the adapter 0V and the I/O 0V to the same line.



- Install an external circuit breaker. Guard against short-circuiting in external wiring.
- Do not connect unused pins. Ignoring this directive may damage the device.
- To avoid damaging wires, do not exceed a maximum torque of 0.5 Nm (5 kgf·cm).
- Do not use tin, solder, or any substance on stripped wire that might cause the wire strand to break.

## Daisy Chaining

To facilitate wiring, you can wire the following pins in series (daisy chain). Use both pins provided for this purpose.

Input connector pin: n/p. Output connector pins: +V, 0V, C0. Power connector pins: +V, 0V.

Ensure that the total current drain on any single line does not exceed 10A. If a specific pin requires more than 10A, connect it with a separate wire. The following diagram demonstrates the wiring options:

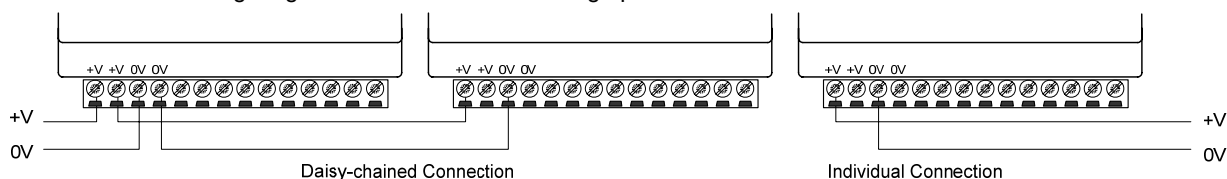

## Wiring the Power Supply

- Always connect the functional earth pin to the earth ground. Use a dedicated wire for this purpose; it must not exceed 1 meter.
- A non-isolated power supply can be used provided that the 0V signal is connected to the earth ground.
- Do not connect the neutral or line signal of the 110/220VAC to the device's 0V pin.
- In the event of voltage fluctuations or non-conformity to voltage power supply specifications, connect the device to a regulated power supply.

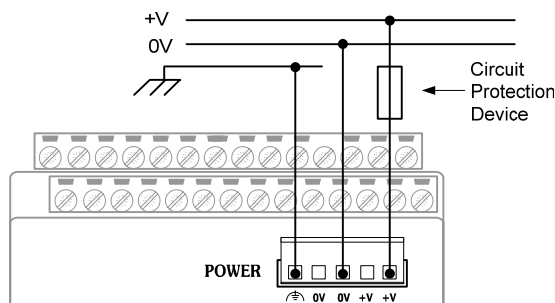

## Wiring Inputs

The following diagram shows the input connectors with pin numbers and corresponding input numbers.

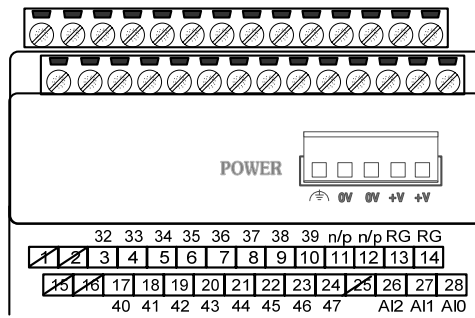

### Wiring Digital Inputs

- Inputs may be wired as either pnp (positive logic) or npn (negative logic).
- Inputs 36 and 38 can function as high-speed counters, frequency measurers, or general purpose digital inputs (set in software).
- Inputs 37 and 39 can function either as counter reset inputs or general purpose digital inputs (set in software).
- For information on connecting RG pins, refer to *Connecting RG Pins*.

#### pnp (positive logic) inputs 32-39

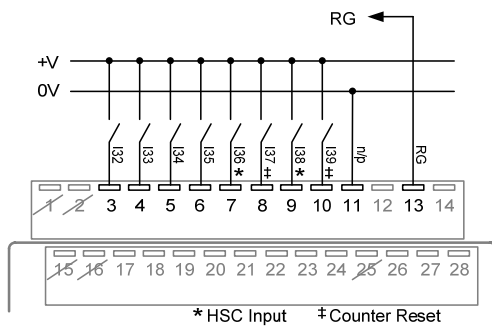

#### pnp (positive logic) inputs 40-47

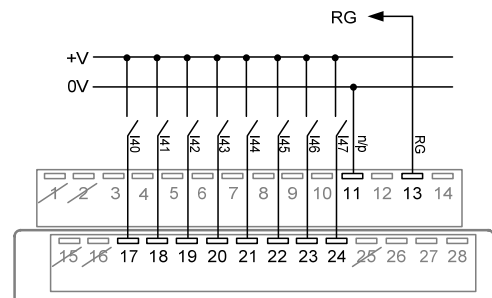

#### npn (negative logic) inputs 32-39

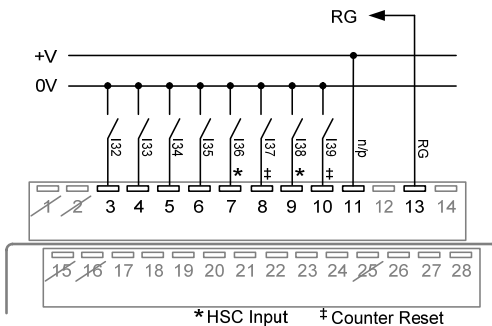

#### npn (negative logic) inputs 40-47

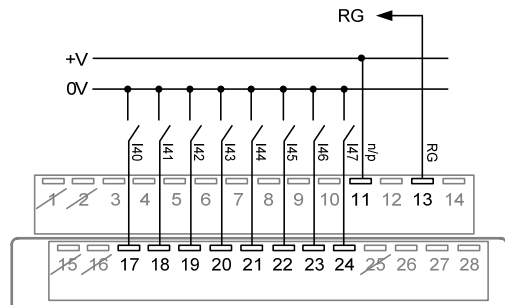

### Wiring Analog Inputs

The following diagram shows the 2-wire and 4-wire current connection.

- Use shielded twisted pair cable.
- Connect shields to the earth ground at the signal's source.

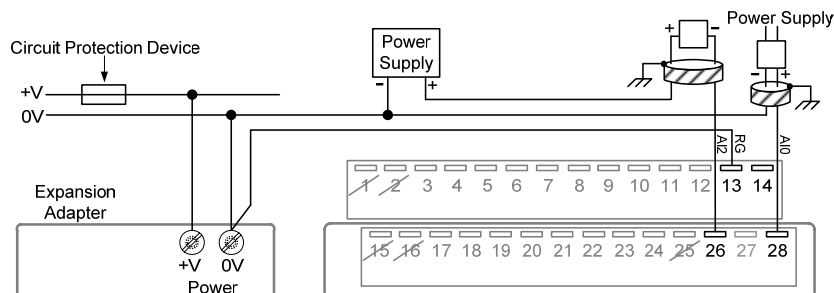

### Connecting RG Pins

For correct operation of digital and analog inputs and for EMI immunity, connect the RG pin of all the expansion modules containing RG signals to the adapter module 0V signal.

- The overall length of the wire connecting the RG pins to the adapter module 0V signal must be less than 3 meters.
- Connect the RG pins in series (daisy chain). To facilitate this, use both the RG pins.

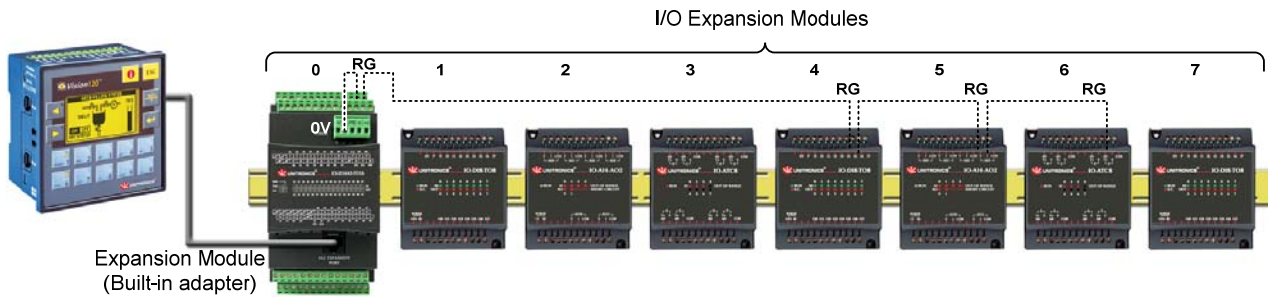

### Wiring Outputs

The following diagram shows the output connector with pin numbers and corresponding output numbers.

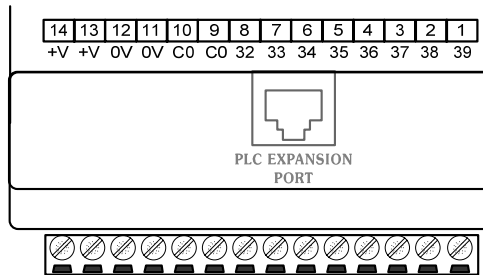

### Wiring the Output Power Supply

- A non-isolated power supply can be used provided that the 0V signal is connected to the earth ground.
- Do not connect the neutral or line signal of the 110/220VAC to the device's 0V pin.
- In the event of voltage fluctuations or non-conformity to voltage power supply specifications, connect the device to a regulated power supply.

### Wiring Relay Outputs

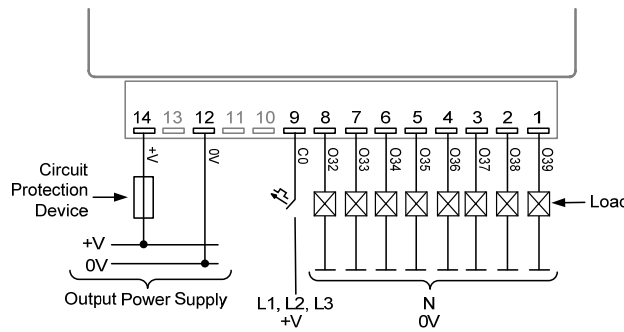

### Increasing Contact Life Span

To increase the life span of the relay contacts and protect against potential damage by reverse EMF, connect one of the following:

- A clamping diode in parallel with each inductive DC load.
- An RC snubber circuit in parallel with each inductive AC load.

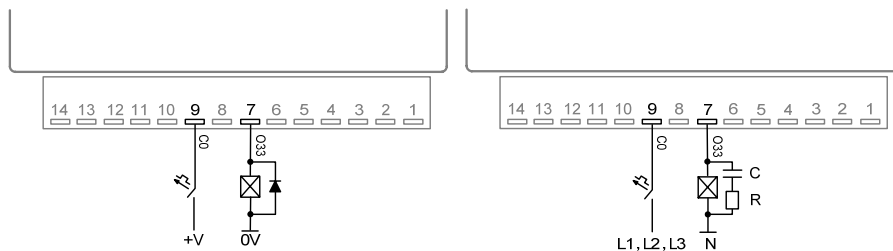

The information in this document reflects products at the date of printing. Unitronics reserves the right, subject to all applicable laws, at any time, at its sole discretion, and without notice, to discontinue or change the features, designs, materials and other specifications of its products, and to either permanently or temporarily withdraw any of the foregoing from the market. All information in this document is provided "as is" without warranty of any kind, either expressed or implied, including but not limited to any implied warranties of merchantability, fitness for a particular purpose, or non-infringement. Unitronics assumes no responsibility for errors or omissions in the information presented in this document. In no event shall Unitronics be liable for any special, incidental, indirect or consequential damages of any kind, or any damages whatsoever arising out of or in connection with the use or performance of this information. The tradenames, trademarks, logos and service marks presented in this document, including their design, are the property of Unitronics (1989) (R'G) Ltd. or other third parties and you are not permitted to use them without the prior written consent of Unitronics or such third party as may own them.