



## Maintenance and Operations Manual

[efesotomasyon.com](http://efesotomasyon.com)

# FLUXMASTER 100

## *AC Inverter*

**230 and 460 Volt  
3 Phase**

**.50 - 30 HP**



# Maintenance and Operations Manual

## Table of Contents

Foreword.....	1
Precautions for Operation .....	3
Environmental Precautions .....	5
General Information .....	7
Specifications.....	9
Wiring.....	11
Keypad Operation.....	14
Parameter List.....	15
Function Description .....	23
Fault Codes.....	53
Maintenance Section.....	58
Dimensions.....	63
Braking Resistors.....	64

## Foreword

To fully employ all the functions of this Inverter, and to ensure the safety for its users, please read through this operations manual in detail. Should you have any further questions, please contact your local TECO-Westinghouse distributor or regional sales representative.

### : Please use Precaution with this Product

The Inverter is a power electronic device. For safety reasons, please read carefully those paragraphs with “WARNING” or “CAUTION” symbols. They are important safety precautions to be aware of while transporting, installing, operating and examining the Inverter. Please follow these precautions to ensure your safety.

 <b>WARNING</b>
--

Personal injury may result from improper operation.

 <b>CAUTION</b>
--

The Inverter or mechanical system may be damaged by improper operation.

<b> WARNING</b>
--

- Do not touch the PCB or components on the PCB right after power has been turned OFF. Charging indicator light must be OFF before examining the components.
- Do not attempt to wire circuitry while power is ON. Do not attempt to examine the components and signals on the PCB while the Inverter is operating.
- Do not attempt to disassemble or modify internal circuitry, wiring, or components of the Inverter while power is ON.
- The Inverter frame must be connected to ground with a suitably rated cable, connected to the Ground Terminal on the Inverter.

<b> CAUTION</b>
--

- Do not attempt to perform dielectric strength test to internal components of the Inverter. The Inverter contains sensitive semiconductor devices that are vulnerable to high voltages.
- Do not connect the output terminals: T1, T2 and T3 to AC power input.
- The CMOS IC on the primary PCB of the Inverter is vulnerable to static electrical charges. Do not handle the primary PCB without the use of proper anti-static equipment.

## **Examination Before Installation**

Every FM100 has been fully tested and examined before shipment. Please carry out the following examination procedures after unpacking your Inverter.

- Check to see if the model number of the Inverter matches the model number of the Inverter that you have ordered.
- Check to see whether any damage occurred to the Inverter during shipment. Do not connect the Inverter to the power supply if there is any sign of damage.

Report any damage that may have occurred to the Inverter during shipment to the freight carrier and your local TECO-Westinghouse distributor or regional sales representative.

## Precautions for Operation

### Before Turning ON Power

#### CAUTION

Choose the appropriate power source with correct voltage settings for the input voltage specification of the Inverter.

#### WARNING

Special care must be taken while wiring the primary circuitry panel. The L1, L2 and L3 terminals must be connected to the input power source and must not be mistakenly connected to T1, T2 or T3 output terminals. This may damage the Inverter when the power is turned ON.

#### CAUTION

- Do not attempt to transport the Inverter by the front cover. Securely hold the Inverter by the heatsink mounting chassis to prevent the Inverter from falling. Failure to do so may cause personal injury or damage to the Inverter.
- Install the Inverter onto a firm metal baseplate or a non-flammable type material. Do not install the Inverter onto or nearby any flammable material.
- An additional cooling fan may need to be installed if several Inverters are installed into one control panel. The temperature inside an enclosed panel should be below 104°F (40°C) to avoid overheating.
- Turn OFF the power supply before performing any work in the control panel. Carry out installation procedures according to instructions. This will help avoid a situation that may result in an operational malfunction.
- This product is not provided with overspeed protection.
- This product is only intended for use in a clean dust and moisture free environment.

### When Power is Applied

#### WARNING

Do not attempt to install or remove input or output connectors of Inverter while the power supply is turned ON. Otherwise, the Inverter may be damaged due to the surge peak caused by the insertion or removal of power.

## Under Operation

### **WARNING**

Do not use a separate device to switch the motor ON or OFF during operation. The Inverter may experience an overcurrent failure.

### **WARNING**

- To avoid personal injury caused by electrical shock, do not remove the front cover of the Inverter while the power is ON.
- When the automatic restart function is enabled, the motor and machinery will restart automatically.

### **CAUTION**

- Do not touch the heatsink base during operation.
- The Inverter can be easily operated at low and high speed ranges. Please reconfirm the operating range of the motor and machinery you are controlling.
- Do not examine the signals on the PCB of the Inverter during operation.
- All Inverters are properly adjusted and factory set before delivery.

### **CAUTION**

Do not proceed with disassembly or examination of the Inverter before ensuring that the power is OFF and that the Power LED has extinguished.

## Performing an Examination or Maintenance

### **CAUTION**

The environment ambient temperature should be within 14<sup>o</sup>F ~ 104<sup>o</sup>F (-10<sup>o</sup>C ~ 40<sup>o</sup>C), with humidity under 95% non-condensing. The Inverter should be free from dripping water and metal dust.

# Environmental Precautions

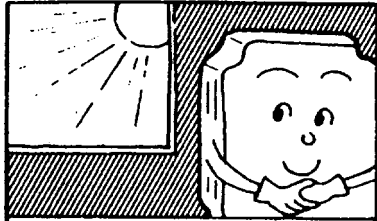

Avoid direct sunlight

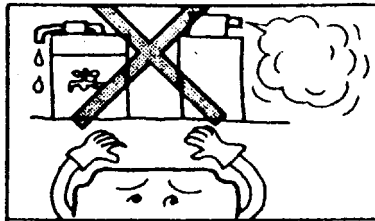

Keep away from corrosive gases and liquids

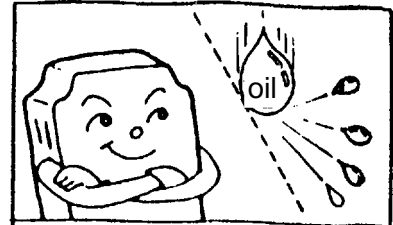

Keep away from oil, grease and gas

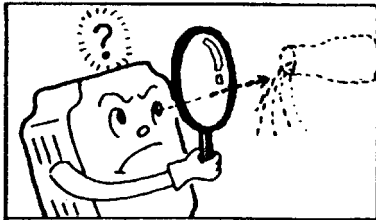

Keep away from salty environments

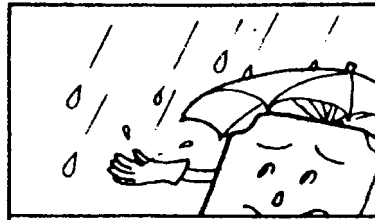

Keep away from rain and dripping water

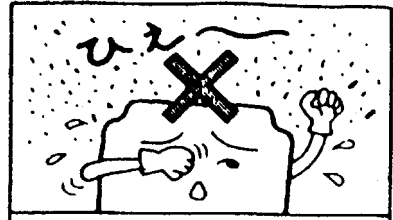

Avoid dusty environments

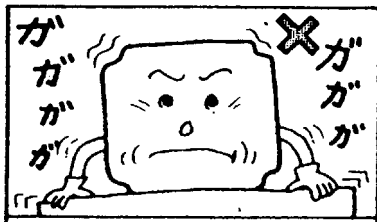

Avoid excessive vibration

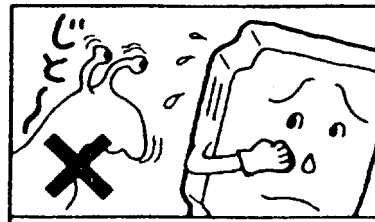

Avoid excessive direct heat

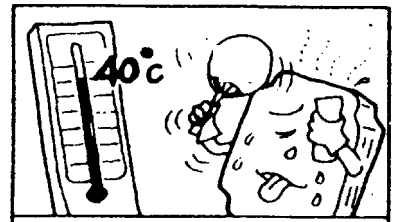

Avoid high temperature environments

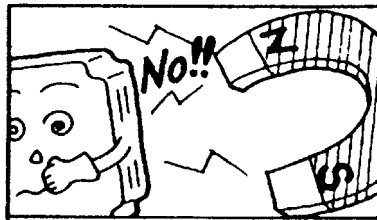

Keep away from high electrical magnetic waves

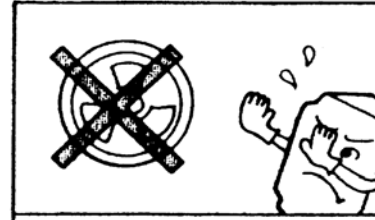

Keep away from radioactive matter

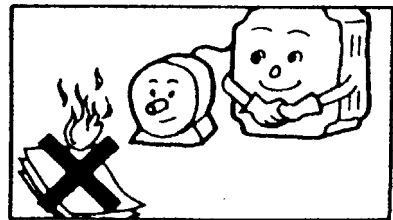

Keep away from flammable material

# Hardware Instructions and Installation

## Operating Conditions

The installation site of the Inverter is important. It has a direct relationship on the functionality and life span of your Inverter. Please carefully consider the following requirements when choosing an installation site:

- Mount the unit vertically.
- Inverter ambient temperature should be within
- Environment ambient temperature should be within 14°F ~ 104°F (-10°C ~ 40°C).
- Avoid placing the Inverter close to any heating equipment.
- Avoid dripping water and humid environments.
- Avoid direct sunlight.
- Avoid oil, grease and gas.
- Avoid contact with corrosive gases and liquids.
- Prevent foreign dusts, flocks, or metal scraps from contacting the Inverter.
- Avoid electric magnetic interference (soldering or power machinery).
- Avoid excessive vibration. If vibration cannot be avoided, an anti-vibration mounting device should be installed to reduce vibration.
- If the Inverter is installed in an enclosed control panel, please add additional cooling using an external fan. This will allow additional airflow and cooling.
- Placement of external fans should be directly over the top of the Inverter.
- For proper installation of the Inverter, you must place the front side of the Inverter facing front and the top of the Inverter in the up direction for proper heat dissipation.

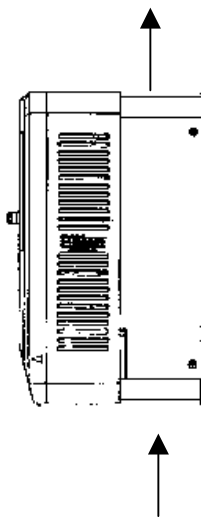
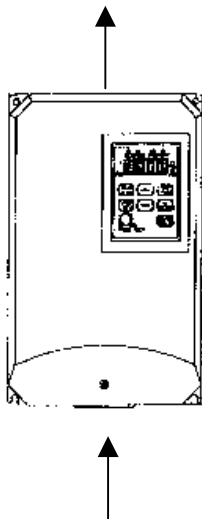

Ventilation &  
Installation Direction  
Front & Side Views

## General Information:

### General

The FM100 series is a General Purpose Inverter that incorporates a high efficiency Pulse Width Modulated (PWM) design and advanced IGBT technology. The output closely approximates a sinusoidal current waveform to allow variable speed control for any conventional squirrel cage induction motor.

### Receiving

This unit has been put through demanding tests at the factory prior to shipment.

Before unpacking please check the following:

1. Identify the description of the product found on the label with your purchase order.
2. Inspect for shipping damage. Serious damage to the carton may indicate damage to the unit.

Please check the following after unpacking:

- a. Check to see if the specifications (current & voltage) on the side of the unit match your application requirement.
- b. Check all the electrical connections and screws.
- c. Verify that there is no visible damage to any of the components.

**IMPORTANT: If any part of the Inverter or the shipping carton is damaged, please notify the carrier and your distributor immediately.**

# Installation:

## Location

Choosing the proper installation location for the Inverter is imperative in order to achieve the maximum specified performance and operation from the FM100. The Inverter should always be installed in areas where the following conditions exist:

- Good ambient operating temperature:  
14°F to 104°F (-10°C to 40°C)
- Enclosure Rating: NEMA 1 for all models. If the Inverter is placed in another enclosure, please provide additional cooling using an external fan.
- Protected from rain and moisture.
- Shielded from direct sunlight.
- Free from metallic particles and corrosive gas.
- Free from excessive vibration. (Below 0.5G)

## Positioning

For effective ventilation and maintenance of the Inverter, provide sufficient clearance (as shown in Figure 2.1) around the Inverter. The Inverter must be installed with heatsink fins oriented vertically.

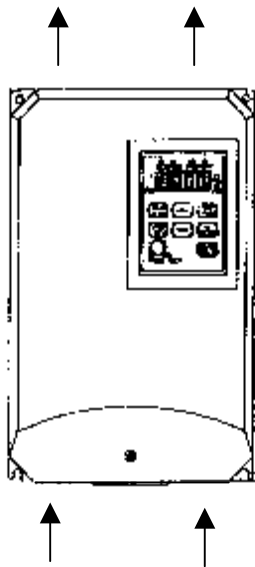

Figure 2.1

- ⇔ Allow 4.72in. (12cm) clearance on both sides of the enclosure.
- ⇔ Be sure to allow the air to move freely through the heatsink area.

**Basic Specification:**

**1 / 3 Phase 200 ~ 240 Volts**

**230 Volts**

<b>FM100-xxx-N1</b>	<b>2P5</b>	<b>201</b>	<b>202</b>	<b>203</b>	<b>205</b>	<b>208</b>	<b>210</b>	<b>215</b>	<b>220</b>	<b>230</b>
Horsepower HP	.50	1	2	3	5	7.5	10	15	20	30
Rated Current A	3.1	4.5	7.5	10.5	17.5	26	35	49	64	87
Output KVA	1.2	1.7	2.9	4.0	6.7	9.9	13.3	18.7	24.4	33.2
Input Voltage	1 / 3 Phase* 200 ~ 240 Volts, + / -10% 50 / 60Hz, + / -5%									
Output Voltage	3 Phase 200 ~ 240 (Proportional to Input Voltage)									
Weight (lbs.)	3.1	3.1	5.5	8.8	8.8	15.0	15.7	27.1	27.6	30.4
Power Loss Ride Through (s)	1	1	1	1	1	2	2	2	2	2

\* Note: .50 - 3HP are rated for 1 / 3 Phase Input. 5HP and above are 3 Phase Input only.

**3 Phase 380 ~ 460 Volts**

**460 Volts**

<b>FM100-xxx-N1</b>	<b>401</b>	<b>402</b>	<b>403</b>	<b>405</b>	<b>408</b>	<b>410</b>	<b>415</b>	<b>420</b>	<b>430</b>
Horsepower HP	1	2	3	5	7.5	10	15	20	30
Rated Current A	2.3	3.8	5.2	8.8	13	17.5	25	32	48
Output KVA	1.7	2.9	4.0	6.7	9.9	13.3	19.1	24.4	36.6
Input Voltage	3 Phase 380 ~ 460 Volts, + / -10% 50 / 60Hz, + / -5%								
Output Voltage	3 Phase 380 ~ 460 Volts (Proportional to Input Voltage)								
Weight (lbs.)	5.3	5.5	8.4	8.8	15.4	16.1	27.1	27.6	29.8
Power Loss Ride Through (s)	1	1	1	1	2	2	2	2	2

## Functional Specification:

<b>Control Characteristics</b>	Carrier Frequency	1 - 12KHz	
	Frequency Control Range	0.1 - 400Hz	
	Frequency Accuracy	Digital: 0.01%; Analog: 0.4%	
	Frequency Resolution	Digital Keypad Reference: 0.01Hz (0 - 99.9Hz); 0.1Hz (100 - 400Hz)	
	Frequency Setting Signal	0 - 5VDC, 0 - 10VDC, 0 - 20mA, 4 - 20mA	
	Accel / Decel Time	0.1 - 3600 Seconds (Two Independent Accel / Decel or S-Curve Settings)	
	Braking Torque	Approx. 20% (Braking Transistor Unit is built-in to 10HP units and below)	
	V/F Pattern	18 Preprogrammed Patterns (One Custom Pattern)	
<b>Protection Function</b>	Instantaneous Overcurrent	Approximately 200% of Rated Current	
	Overload Protection	150% Rated Output Current for 60 Seconds	
	Motor Overload	Electronic Thermal Overload Relay	
	Overvoltage	230V Series: (DC Bus exceeds 427V) 460V Series: (DC Bus exceeds 854V)	
	Undervoltage	230V Series: (DC Bus Voltage drops below 200V) 460V Series: (DC Bus Voltage drops below 400V)	
	Momentary Power Loss	.7 - 2 Seconds: FM100 can be restarted with Speed Search	
	Heatsink Overheat	Protected by Thermostat	
<b>Operating Conditions</b>	Input Signals	Operation Signal	Forward / Reverse Operation, by Keypad or Hardwired Contact, Multiple Individual Commands
		Reset	Released Protection while the Protect Function is Operating
		Multi-Functional Inputs	Refer to Function Illustration in <b>Fn_56</b>
	Output Signal	Multi-Functional Output	Refer to Function Illustration in <b>Fn_61</b>
		Fault Contact	250VAC 1A, 30VDC 1A or less
	Built-in Function	Frequency Reference Bias / Gain; Upper and Lower Limit; Manual Torque Boost; Frequency Meter Gain; Auto Restart; Skip Frequency; S-Curve Accel / Decel; Carrier Frequency Adjust; Communication Link Function	
	Digital Keypad Monitor	4 Digit 7 Segment LED Display Indicates: Frequency; Output Frequency; Speed; Output Current; Output Voltage; Bus Voltage; Rotating Direction	
	Analog Output Monitor	0 - 10VDC Analog Output, Possible to Select: Output Frequency; Setting Frequency; Output Voltage; Bus Voltage	
<b>Environmental Conditions</b>	Location	Indoor (Protected from Corrosive Gases and Dust)	
	Ambient Temperature	+14°F ~ 104°F (-10°C ~ 40°C)	
	Humidity	0 - 95% (Non-Condensing)	
	Vibration	0.5G (4.9m/s <sup>2</sup> )	
Enclosure	NEMA 1		
UL	UL508C		

# Wiring & Remote Operating Functions:

## External Connections

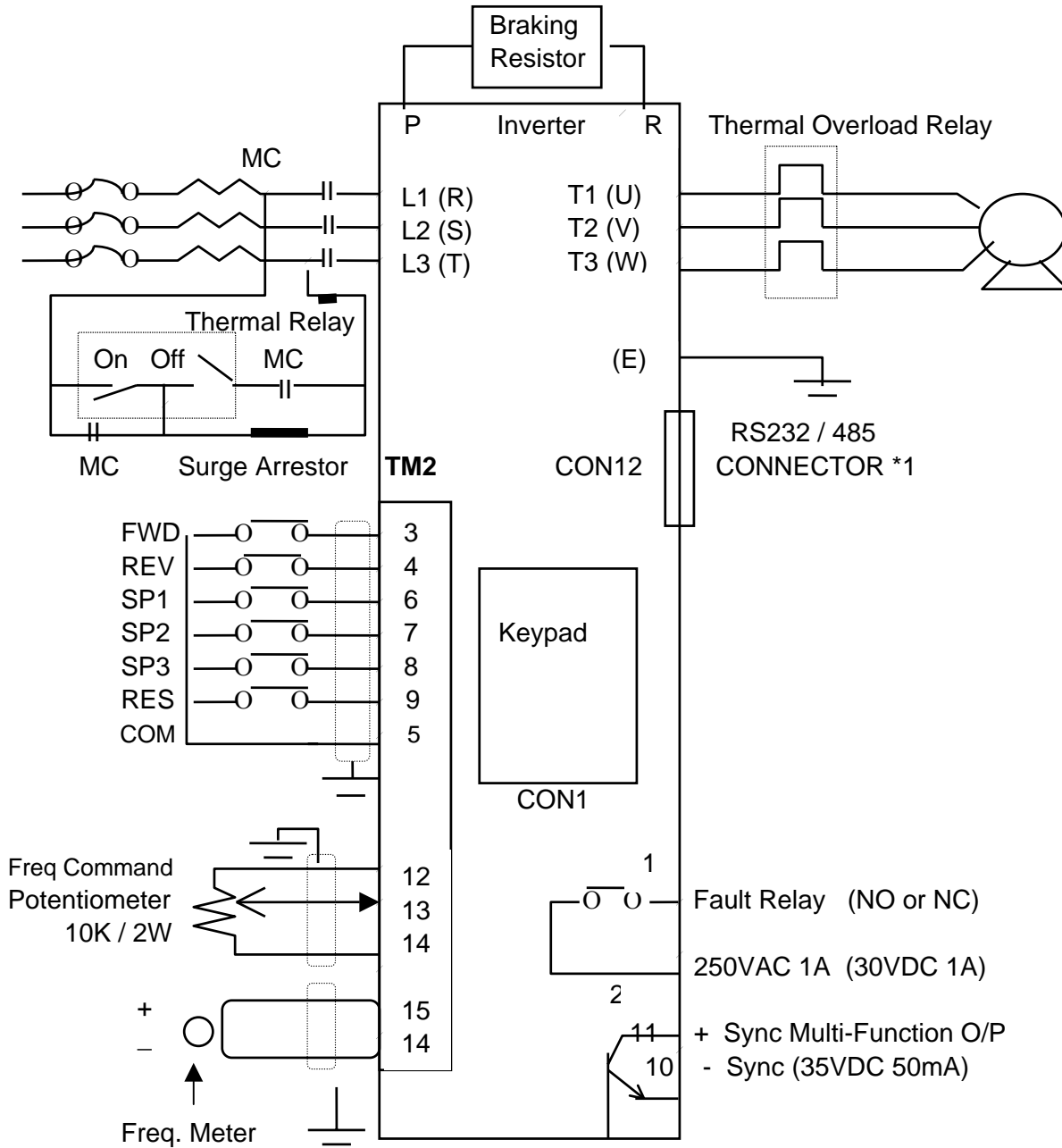

\*1: For .50HP 230 Volt Units, please use Jumper to short Pin 1 and Pin 2 of CON12 when CON12 is not used.

# General Wiring Instructions:

Note:

The FM100 can be completely controlled by the Digital Keypad. If you chose to use the **TM2** control terminal strip, please see the following instructions.

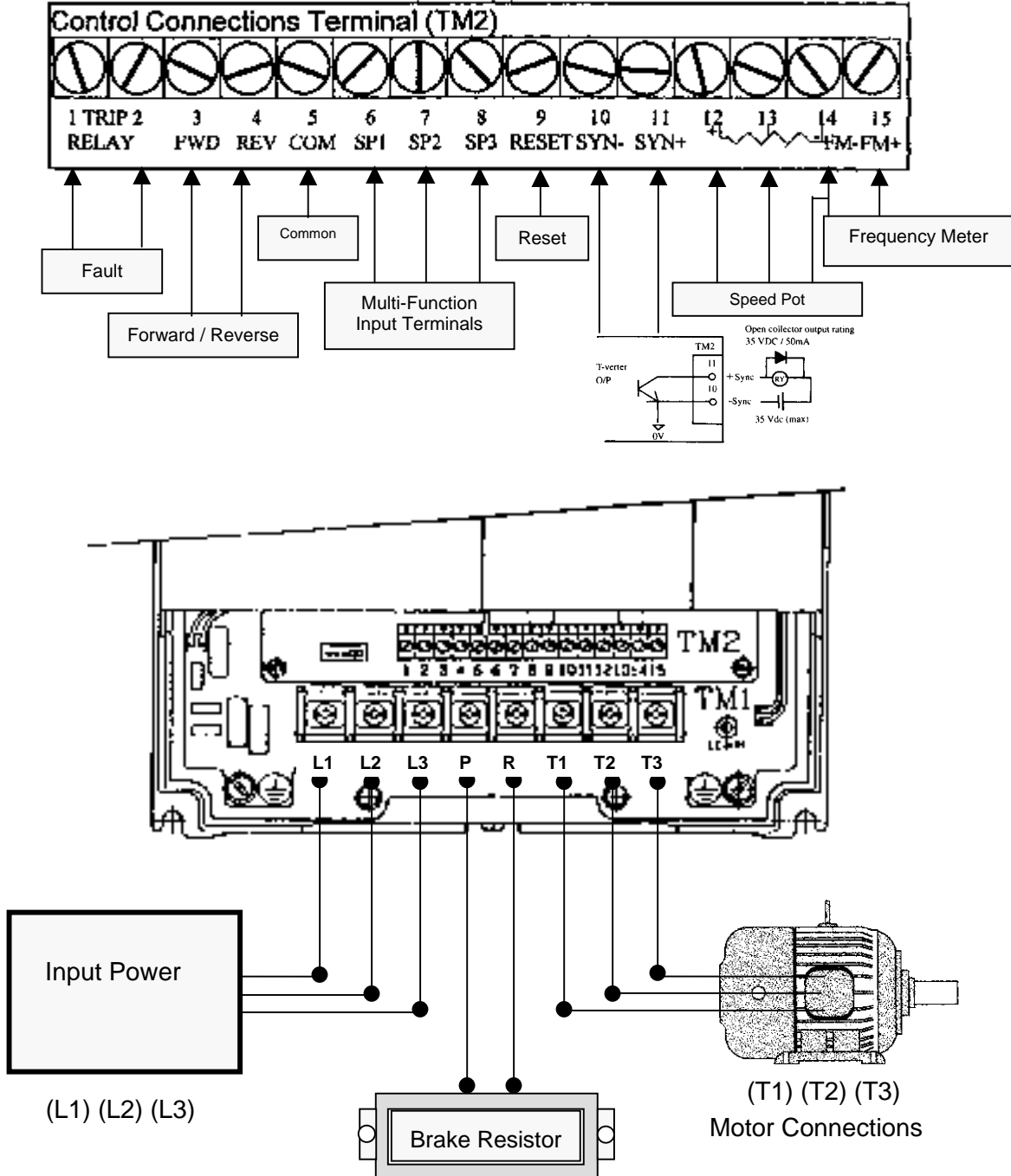

## Function Description for the Main Circuit Power Terminals (TM1)

SYMBOL	FUNCTION DESCRIPTION
L1 (R)	Input Terminals of AC Line Power: 230 or 460 Volt Single Phase: L1 / L2 Three Phases: L1 / L2 / L3
L2 (S)	
L3 (T)	
P	External Braking Resistor Terminals
R	
T1 (U)	Output Terminals to Motor
T2 (V)	
T3 (W)	

## Function Description for the Control Terminals (TM2)

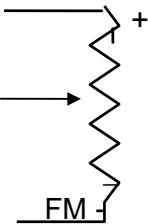
	SYMBOL	FUNCTION DESCRIPTION
1	TRIP	Fault Relay Output Terminals: (Fn_97, 98) Contact Rating: 250VAC / 1A (30VDC / 1A)
2	RELAY	
3	FWD	Operation Control Terminals (Fn_03)
4	REV	
5	COM	Ground Common for Terminals 3 / 4 / 6 / 7 / 8 / 9
6	SP1	
7	SP2	
8	SP3	Multi-Function Input Terminals (Fn_56)
9	RESET	Reset Terminal (Fn_16)
10	SYN-	Negative Terminal for Multi-Function Output (Fn_61)
11	SYN+	Positive Terminal for Multi-Function Output (Fn_61)
12		+5V Power Terminal of Potentiometer (Pin 3)
13		Analog Input Positive Terminal (Fn_26) 0 - 5VDC, 0 - 10VDC, 4 - 20mA
14		Analog Common Negative Terminal (Fn_46) 0 - 5VDC, 0 - 10VDC, 4 - 20mA
15	FM +	Analog Output (+) Multi-Function Output Terminal (Fn_46) Range of Output Signal: 0 - 10VDC

## Keypad Operations:

### Keypad Illustration

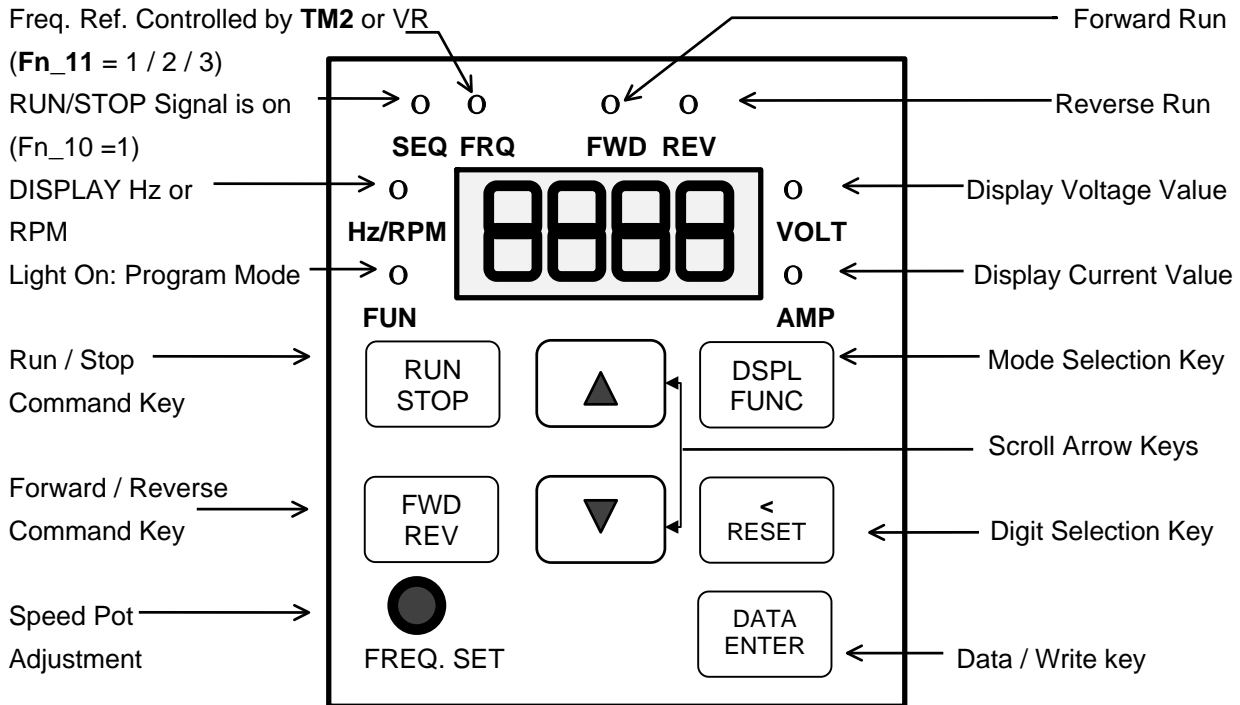

### Keypad Function:

	⇔ RUN / STOP Button used for START / STOP Commands from the Keypad
	⇔ DSP / FUN Button used for Displaying Functions and Monitors
	⇔ FWD / REV Button used for Forward / Reverse Commands from the Keypad
	⇔ < / RESET Button used for moving Diagonally and Resetting the Drive
	⇔ DATA / ENTER used for Reading and Entering Functions
	⇔ ▲ ▼ Arrows are used for Navigating and Changing Parameters

## Parameter List

Function	Fn_ xx	Description	Engineering Units	Range	Factory Setting	Page
Drive Capacity	0	Drive Capacity Selection	1	1 - 18	*3	23
Accel Time	1	Accel Time 1	0.1 sec	0.1 - 3600 sec	10 sec	23
Decel Time	2	Decel Time 1	0.1 sec	0.1 - 3600 sec	10 sec	23
Stop / Start Control <b>TM2</b>	3	xx00 : FWD / STOP, REV / STOP xx01 : FWD / REV, RUN / STOP xx10 : 3-Wire Start / Stop Control x0xx : REV Command Enable x1xx : REV Command Disable 0xxx : Setting Frequency will remain at last Output Frequency when Inverter stops and <b>Fn_11 = 3</b> 1xxx : Setting Frequency will be 0 (zero) when Inverter stops and <b>Fn_11 = 3</b>			0000	24
Parameter Lockout	4	xxx0 : Enable ( <b>Fn_17 - 25</b> ) xxx1 : Disable ( <b>Fn_17 - 25</b> ) xx0x : Enable (Functions except <b>Fn_17 - 25</b> ) xx1x : Disable (Functions except <b>Fn_17 - 25</b> )			0000	25
V/Hz Pattern	5	V/Hz Pattern Selection	1	0 - 18	9 / 0	25
Frequency Limit	6	Frequency Upper Limit	0.01Hz	0 - 400Hz	60 / 50	27
	7	Frequency Lower Limit	0.01Hz	0 - 400Hz	0Hz	27
Target Speed	8	Target Frequency Setting	0.01Hz	0 - 400Hz	0Hz	27
Target Speed Bandwith	9	Frequency Setting Detection Width (+ / - F9 / 2)	0.01Hz	0 - 30Hz	0Hz	27
START / STOP Selection	10	0 : Keypad 1 : <b>TM2</b>			0	28
Frequency Command Selection	11	0 : Controlled by ( <b>Fn_25</b> ) Master Reference at Keypad 1 : Controlled by Keypad Frequency Setting Potentiometer 2 : Controlled by <b>TM2</b> (Speed Pot) 3 : Controlled by Preset Speeds or Multi-Function Inputs (Terminals 6 / 7 / 8)			0	28

Function	Fn_ xx	Description	Engineering Units	Range	Factory Setting	Page
Stall Prevention	12	xxx0 : Stall Prevention during Accel enable xxx1 : Stall Prevention during Accel disable xx0x : Stall Prevention during Decel enable xx1x : Stall Prevention during Decel disable x0xx : Stall Prevention during Run enable x1xx : Stall Prevention during Run disable 0xxx : Stall Prevention Decel Time set by <b>Fn_02</b> 1xxx : Stall Prevention Decel Time set by <b>Fn_15</b>			0000	29
Stall Prevention	13	Stall Prevention starting level during Accel	1%	30 - 200%	110%	29
	14	Stall Prevention Level during Run	1%	30 - 200%	160%	29
	15	Decel Time during Stall Prevention	0.1 sec	0.1 - 3600 sec	3 sec	29
Direct Start & Reset and Numbers of Input Signal Scanning	16	xxx0 : Direct Start enable when remote RUN command ON xxx1 : Direct Start disable when remote RUN command ON xx0x : Reset effective only if remote RUN command OFF xx1x : Reset effective disregard of remote RUN command condition 00xx : <b>TM2</b> will scan 10 times 01xx : <b>TM2</b> will scan 5 times 10xx : <b>TM2</b> will scan 3 times 11xx : <b>TM2</b> will scan 1 time			0000	30
Preset Speeds	17	Preset Speed 1	0.01Hz	0 - 400Hz	5.00Hz	30
	18	Preset Speed 2	0.01Hz	0 - 400Hz	10.00Hz	30
	19	Preset Speed 3	0.01Hz	0 - 400Hz	20.00Hz	30
	20	Preset Speed 4	0.01Hz	0 - 400Hz	30.00Hz	30
	21	Preset Speed 5	0.01Hz	0 - 400Hz	40.00Hz	30
	22	Preset Speed 6	0.01Hz	0 - 400Hz	50.00Hz	30
	23	Preset Speed 7	0.01Hz	0 - 400Hz	60.00Hz	30
Jog Speed	24	Jog Frequency Reference	0.01Hz	0 - 400Hz	2.00Hz	31
Master Frequency	25	Master Frequency Reference from the Keypad	0.01Hz	0 - 400Hz	5.00Hz	31
Analog Input Frequency Command	26	Frequency Reference	0.01Hz	0.0 - 400Hz	0Hz	32
	27	Voltage Reference Ratio 1	0.1%	0 - 100.0%	0%	32
	28	Voltage Reference Ratio 2	0.1%	0 - 999.9%	100%	32

Function	Fn_xx	Description	Engineering Units	Range	Factory Setting	Page
Direction + / -	29	Positive / Negative Direction	1	0 : Positive 1 : Negative	0	32
Power Voltage	30	Input Voltage of Power Supply	0.1V	200 - 480V	*3	33
Momentary Power Loss Ride Through	31	Momentary Power Loss Ride Through Time	0.1 sec	.7 - 2 sec	0.5 sec	33
	32	xxx0 : Disable xxx1 : Enable			0	33
	33	Reserved for Future Use				33
Auto Restart	34	Auto Restart Time	0.1 sec	0 - 800 sec	0 sec	33
	35	No. of Auto Restart Attempts	1	0 - 10	0	33
Motor Poles	36	No. of Motor Poles	2P	2 - 8 pole	4P	33
V/Hz Pattern	37	Max. Frequency	0.01Hz	50 - 400Hz	60 / 50Hz	34
	38	Max. Voltage Ratio	0.1%	0 - 100%	100%	34
	39	Mid. Frequency	0.01Hz	0.11 - 400Hz	3.0 / 2.5Hz	34
	40	Mid. Voltage Ratio	0.1%	0 - 100%	7.5%	34
	41	Voltage Ratio at 0.1Hz	0.1%	0 - 100%	7.5%	34
Starting Freq.	42	Start Frequency Adjustment	0.01Hz	0.1 - 10Hz	1Hz	35
Carrier Freq.	43	Carrier Frequency Adjustment	1	0 - 15	14	35
Stopping Mode and Braking Resistor Protection	44	xxx0 : Decel to Stop xxx1 : Coast to Stop xx0x : Braking Resistor Thermal Protection disable xx1x : Braking Resistor Thermal Protection enable			0000	35
Multi-Function Analog Output Selection (Terminals) (14 & 15)	45	Gain : Analog Output	1%	0 - 200%	100%	36
	46	0 : Output Frequency ( <b>Fn_6</b> Max.) 1 : Set Frequency ( <b>Fn_6</b> Max.) 2 : Output Voltage 3 : Bus Voltage			0	36
Display Mode	47	xxx0 : Output Voltage (VAC) Display disable xxx1 : Output Voltage (VAC) Display enable xx0x : Bus Voltage (VDC) Display disable xx1x : Bus Voltage (VDC) Display enable x0xx : Output Current (IAC) Display disable x1xx : Output Current (IAC) Display enable			0000	36

Function	Fn_ xx	Description	Engineering Units	Range	Factory Setting	Page
Dynamic Braking and Priority of Stopping and Speed Search & AVR Control	48	xxx0 : Enhanced Braking Capacity xxx1 : Standard Braking Capacity xx0x : STOP Key effective in Remote Control Mode xx1x : STOP Key ineffective in Remote Control Mode x0xx : Speed Search controlled by Terminals on <b>TM2</b> x1xx : Speed Search effective during Inverter Start 0xxx : AVR Function effective 1xxx : AVR Function ineffective			0000	37
Accel / Decel	49	Accel Time 2	0.1 sec	0.1 - 3600 sec	10.0 sec	37
Time 2	50	Decel Time 2	0.1 sec	0.1 - 3600 sec	10.0 sec	37
Display mode	51	Display Mode Selection	1	0 - 5	0	37
	52	Engineering Units	1	0 - 9999	1800	37
DC Braking	53	DC Braking Time	0.1 sec	0 - 25.5 sec	0.5 sec	38
	54	DC Braking Injection Freq.	0.1Hz	0.1 - 10Hz	1.5Hz	38
	55	DC Braking Level	0.1%	0 - 20%	8%	38
Multi-Function Inputs	56	Multi-Function Input 1 (Terminal 6)	00 : SP1 01 : SP2 02 : SP3		00	38
	57	Multi-Function Input 2 (Terminal 7)	03 : Jog 04 : Accel / Decel Time Selection 05 : External Emergency Stop		01	38
	58	Multi-Function Input 3 (Terminal 8)	06 : External Coast Stop 07 : Speed Search		02	38
	59,60	Reserved for Future Use				38
Multi-Function Output	61	Multi-Function Output 1 (Terminals 10 & 11)	00: Run Mode		00	40
			01: At Target Speed 02: Set Frequency (Fn_08/09)			40
				03 Frequency Detection (Fn_08)		40
		62	Reserved for Future Use	04 Frequency Detection (Fn_08)		40
		63	Reserved for Future Use	05 Overcurrent Detection		40
				06 Change 00 - 05 (NO) (NC)		40

Function	Fn_xx	Description	Engineering Units	Range	Factory Setting	Page
Skip Frequency Control	65	Setting Prohibited Freq. 1	0.01Hz	0 - 400Hz	0Hz	41
	66	Setting Prohibited Freq. 2	0.01Hz	0 - 400Hz	0Hz	41
	67	Setting Prohibited Freq. 3	0.01Hz	0 - 400Hz	0Hz	41
Bandwidth	68	Setting Prohibited Freq. Range	0.01Hz	0 - 10Hz	0Hz	41
Electronic Thermal Overload Protection	69	xxx0 : Electronic Thermal Motor Protection enable xxx1 : Electronic Thermal Motor Protection disable xx0x : Electronic Thermal Characteristics in accordance with a Standard Motor xx1x : Electronic Thermal Characteristics in accordance with a Special Motor x0xx : <u>Constant Torque</u> Inverter Protection OL : 103% Continuous 150% for 60 seconds x1xx : <u>Variable Torque</u> Inverter Protection OL : 113% Continuous 123% for 60 seconds 0xxx : Coast to Stop after Electronic Thermal Motor Protection is energized 1xxx : Operation continued after Electronic Thermal Motor Protection is energized			0000	41
Reference Amps	70	Motor Rated Current	0.1A	-	Specs.	41
Torque Boost	71	Torque Boost Selection				44
	72	Torque Boost Gain	0.1%	0.0 - 10.0%	0.0%	44
	74	Reserved for Future Use				44
	75	Motor No Load Current				44
Slip Compensation	76	Motor Rated Slip	0.01Hz	0.00 - 6.00Hz	0.00Hz	44
Overtorque Control	77	xxx0 : Overtorque Detection disable xxx1 : Overtorque Detection enable xx0x : Enable only if at Set Frequency xx1x : Enable during Operation x0xx : Operation continued after Overtorque is Detected x1xx : Coast to Stop after Overtorque is Detected			0000	44
	78	Overtorque Detection Level	1%	30 - 200%	160%	45
	79	Overtorque Detection Time	0.1 sec	0 - 25 sec	0.1 sec	45

Function	Fn_ xx	Description	Engineering Units	Range	Factory Setting	Page
S-Curve	80	S-Curve Time 1 in the period of Accel / Decel Time 1	0.1 sec	0 - 4 sec	0.2 sec	46
	81	S-Curve Time 2 in the period of Accel / Decel Time 2	0.1 sec	0 - 4 sec	0.6 sec	46
Energy Savings	82	xx00: Energy Savings disable xx01: Energy Savings controlled by Multi-Function Input Terminals using the Preset Speed Functions xx0x: Set Freq. Output after Process Timer finishes counting			0000	47
	83	Energy Saving Gain	1%	0 - 100%	80%	47
Sequence Control	84	xxx0 : Process Timer disable xxx1 : Process Timer enable xx0x : Set Freq. Output after Process Timer finishes counting xx1x : Zero Speed Output after Process Timer finishes counting			0000	48
Process Timers	85	Process Timer 1	0.1 sec	0 - 3600 sec	0 sec	49
	86	Process Timer 2	0.1 sec	0 - 3600 sec	0 sec	49
	87	Process Timer 3	0.1 sec	0 - 3600 sec	0 sec	49
	88	Process Timer 4	0.1 sec	0 - 3600 sec	0 sec	49
	89	Process Timer 5	0.1 sec	0 - 3600 sec	0 sec	49
	90	Process Timer 6	0.1 sec	0 - 3600 sec	0 sec	49
	91	Process Timer 7	0.1 sec	0 - 3600 sec	0 sec	49
Vibration Control	92	Vibration Control Times	1	1 - 100	5	49
	93	Vibration Control Gain	0.1%	0 - 100%	0%	49
	94	Vibration Control Bias	1%	0 - 30%	0%	49
	95	Parameters for Factory Adjustment				50
	96	Do Not Change				50
Fault Contact Control	97	xxx0 : Fault Contact is Not energized during Auto Restart Operation xxx1 : Fault Contact is energized during Auto Restart Operation xx0x : Fault Contact is Not energized during Momentary Power Loss Detection xx1x : Fault Contact is energized during Momentary Power Loss Detection			0000	50

Function	Fn_ xx	Description	Engineering Units	Range	Factory Setting	Page
Fault Contact Control (Continued)	97	x0xx : Fault Contact is Not energized during External Emergency Stop x1xx : Fault Contact is energized during External Emergency Stop 0xxx : Fault Contact is Not energized during External Base Block 1xxx : Fault Contact is energized during External Base Block			0000	50
Fault Contact Control	98	xxx0 : Fault Contact is Not energized after Overtorque is Detected xxx1 : Fault Contact is energized after Overtorque is Detected xx0x : Fault Contact is Not energized after Electronic Thermal Motor Protection is activated xx1x : Fault Contact is energized after Electronic Thermal Motor Protection is activated x0xx : Fault Contact is Normally Open (NO) x1xx : Fault Contact is Normally Closed (NC) 0xxx : Fault Contact is Not energized after Electronic Thermal Inverter Protection is activated 1xxx : Fault Contact is energized after Electronic Thermal Inverter Protection is activated			0000	50
Parameter Control for Communication	99	Reserved for Future Use				50
	100	Communication Address	1	1 - 32	*3	51
	101	Baud Rate of Communication	1	0 : 4800 bps 1 : 9600 bps 2 : 19200 bps 3 : 38400 bps	*3	51
Parameter Control for Communication	102	xxx0 : 1 Stop Bit xxx1 : 2 Stop Bits xx0x : Even Parity xx1x : Odd Parity x0xx : With Parity x1xx : Without Parity 0xxx : 8 Bits Data 1xxx : 7 Bits Data	*3	52		51

Function	Fn_ xx	Description	Engineering Units	Range	Factory Setting	Page
	103	For Factory Setting Only				0
	106	Reserved for Future Use				0
	107	Reserved for Future Use				0
	108	Reserved for Future Use				0
	109	Reserved for Future Use				0
	110	Reserved for Future Use				0
	111	Reserved for Future Use				0
	112	Reserved for Future Use				0
	113	Reserved for Future Use				0
	114	Reserved for Future Use				0
	115	Reserved for Future Use				0
	116	Reserved for Future Use				0
	117	Reserved for Future Use				0
	118	Reserved for Future Use				0
	119	Reserved for Future Use				0
	120	Reserved for Future Use				0
	121	Reserved for Future Use				0
	122	Reserved for Future Use				0
Return to Factory Setting	123	1111 : Reset to Factory Setting (for 60Hz Power System) 1110 : Reset to Factory Setting (for 50Hz Power System)			0000	52
CPU Version	124	CPU Software Version			*3	52
Fault Log	125	Fault Log for Last Three Faults			1. --- 2. --- 3. ---	53

#### SETTING THE RANGE:

The setting of the Accel & Decel Times along with the frequency are only 4 digits when set by the Keypad (for example: 3599 sec / 399.9Hz).

5 digits (for example: 3599.9 sec or 399.99 Hz) are available when controlled by a programmable controller (PLC) or computer communication mode.

## Function Description

**Fn\_00: Drive Capacity Selection = 1 - 18**

FN_00	MODEL NUMBER	FN_00	MODEL NUMBER
01	230 Volt .50HP	10	460 Volt 1HP
02	230 Volt 1HP	11	460 Volt 2HP
03	230 Volt 2HP	12	460 Volt 3HP
04	230 Volt 3HP	13	460 Volt 5HP
05	230 Volt 5HP	14	460 Volt 7.5HP
06	230 Volt 7.5HP	15	460 Volt 10HP
07	230 Volt 10HP	16	460 Volt 15HP
08	230 Volt 15HP	17	460 Volt 20HP
09	230 Volt 20/30HP	18	460 Volt 30HP

**Fn\_01: Acceleration Time = 0.1 - 3600 Sec.**

Acceleration time equals the time it takes the Inverter to go from 0 speed to target speed. The Keypad on the Inverter will set the acceleration time.

Press the  (Key), press the up and down arrow keys to find (**Fn\_01**).

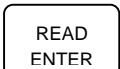
Press the  (Key), press the up and down arrows to change the acceleration time.

Press the  (Key), again to store the setting.

**Fn\_02: Deceleration Time = 0.1 - 3600 Sec.**

Deceleration time equals the time it takes the Inverter to go from one target speed to a slower target speed. The programming of the Deceleration function is the same as the Acceleration function above.

## Fn\_03: START / STOP Control From TM2

### Fn-03: START / STOP Control for Remote Operation

xxx0: FWD / STOP, REV / STOP

xx01: FWD / REV, RUN / STOP

xx10: 3-Wire Control

x0xx: REV Command enable

x1xx: REV Command disable

0xxx: During **Fn\_11** = 3 (**TM2** up / down control).

The setting frequency will remain at the last operational frequency when stopped.

x1xx: During **Fn\_11** = 3 (**TM2** up / down control).

Note: 1: **Fn\_03** will be enabled only when **Fn\_10** = 1 (Remote Control).  
 2: The STOP" key on the Keypad can be use for Emergency Stopping at any time.  
 (Refer to Fn\_48 for additional stopping functions)

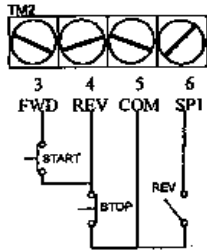

Momentary START / STOP Switch:

Maintained FORWARD and REVERSE Switch:

Set: (**Fn\_10** to 1)

Set: (**Fn\_03** to 3-Wire Control) (XX10)

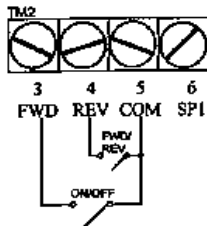

Maintained ON / OFF Switch:

Maintained FORWARD / REVERSE Switch:

Set: (**Fn\_10** to 1)

Set: (**Fn\_03** to (XX01))

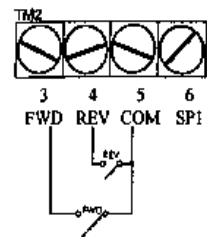

Maintained FORWARD Switch:

Maintained REVERSE Switch:

Set: (**Fn\_10** to 1)

Set: (**Fn\_03** to (0000))

## Fn\_04: Parameter Lockout

Parameter Lock Select	xxx0	Disable (Fn_17-25)
	xx01	Enable (Fn_17-25)
	xx0x	Disable (Functions except Fn_17-25)
	xx1x	Enable (Functions except Fn_17-25)

## Fn\_05: V/Hz Pattern Setting / Custom or Preprogrammed

V/F Pattern Selection = 0 - 18 (See Page 24)

Fn_30: Voltage of Input Power Supply	= 200 - 480 Volts
Fn_37: Maximum Frequency	= 50 - 400Hz
Fn_38: Maximum Voltage Ratio	= 0 - 100%
Fn_39: Middle Frequency	= 0.11 - 400Hz
Fn_40: Middle Voltage Ratio	= 0 - 100%
Fn_41: Voltage Ratio at 0.1Hz	= 0 - 100%
Fn_48: AVR Control	= 0xxx, AVR Function effective = 1xxx, AVR Function ineffective

In order to build Custom V/Hz Patterns, (Fn\_05) must be set at 18.  
Please refer to (Fn\_37) and (Fn\_41).

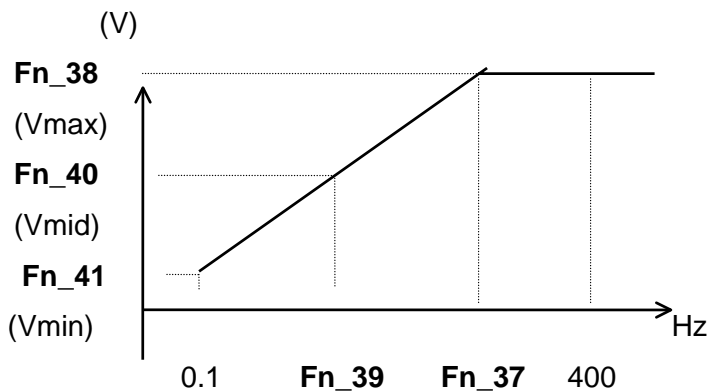

**Fn\_05:**

**= 0 - 17 V/Hz Curves**

	Fn_05	50Hz	Fn_05	60Hz
General Purpose	0		9	
	1		10	
High Starting Torque	2		11	
	3		12	
Variable Torque Operation	4		13	
	5		14	
Constant HP Operation	6		15	
	7		16	
	8		17	

Fn_05	B	C
0/9	7.5%	7.5%
1/10	10.0%	7.5%
2/11	15.0%	7.5%
3/12	20.0%	7.5%

Fn_05	B	C
4/13	17.5%	7.5%
5/14	25.0%	7.5%
6/15	15.0%	7.5%
7/16	20.0%	7.5%
8/17	25.0%	7.5%

Note: The Automatic Voltage Regulator (AVR) will determine the actual output voltage when (Fn\_05) is set to 18.

**Fn\_06: Frequency Upper Limit**

The maximum speed of the motor is adjusted by raising the Frequency Upper Limit at (Fn\_06).

**Fn\_07: Frequency Lower Limit**

The minimum speed for the motor is adjusted by the Frequency Lower Limit at (Fn\_07).

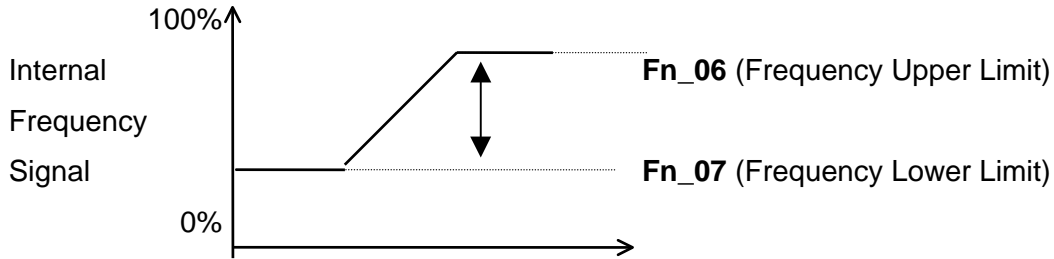

**Fn\_08: At Target Speed**

**0 - 400Hz**

The Multi-Function Output (Terminals 10 & 11) can be programmed to close at a predetermined target speed. (Fn\_65) must be programmed to 1 and (Fn\_08) must be programmed with the desired target speed.

**Fn\_09: Target Speed Bandwidth**

**0 - 30Hz**

The Target Speed Bandwidth function can be used to close the Multi-Function Output (Terminals 10 & 11) at (Fn\_61). See Page 47

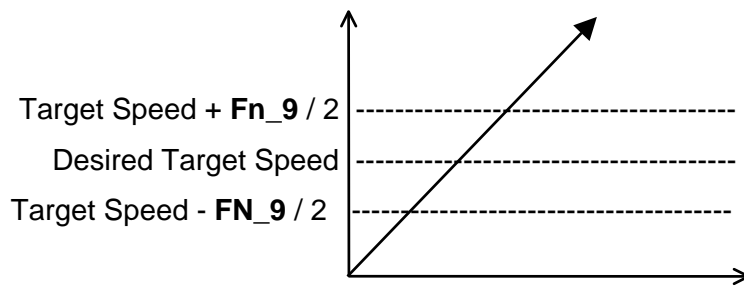

Note: Terminals 10 and 11 are Normally Open during Power OFF, and Normally Closed during Power ON.

## Fn\_10: START / STOP Control

This parameter is used to decide if the Start and Stop function will be controlled by the Keypad or by Remote Operation (**TM2**).

**0:** Keypad Control

**1:** Remote Operation (**TM2**)

### Note:

The STOP Key on the Keypad can still be used for Emergency Stopping even if the START / STOP Control is from **TM2** (**Fn\_10** = 1). (Refer to **Fn\_48**)

## Fn\_11: Frequency Command Selection

**0:** Run by **Fn\_25** Master Reference

**1:** Run by Frequency Setting Potentiometer on Keypad

**2:** Run by Speed Pot on **TM2** or Remote Signal (Terminals (12 / 13 / 14))

**3:** Run by Multi-Function Input Frequency Command (Terminals 6 / 7 / 8))

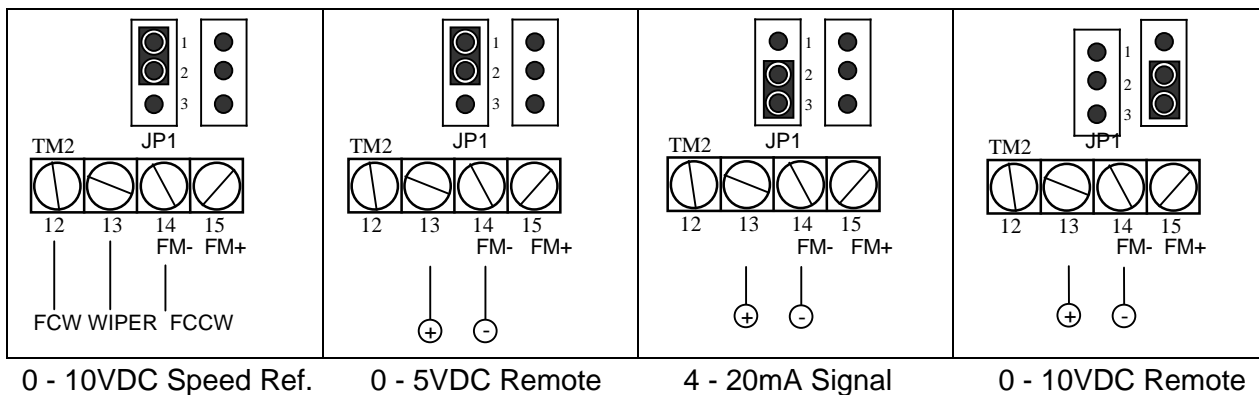

<p><b>(Fn_11)</b> to 2 Use a (10K, 2 Watt) Pot with the wiper in Terminal 13. Jumper (<b>JP1</b>) Pins 1 &amp; 2.</p>	<p><b>(Fn_11)</b> to 2 For a Remote 5VDC Signal, Jumper (<b>JP1</b>) Pins 1 &amp; 2.</p>	<p><b>(Fn_11)</b> to 2 For a Remote 4 - 20mA Signal, Jumper (<b>JP1</b>) Pins 2 &amp; 3.</p>	<p><b>(Fn_11)</b> to 2 For a Remote 0 - 10VDC Signal, Jumper (<b>JP2</b>) Pins 2 &amp; 3.</p>
---	--	--	---

## **Fn\_12: Stall Prevention**

<b>xxx0:</b>	Stall Prevention during Acceleration enable
<b>xxx1:</b>	Stall Prevention during Acceleration disable
<b>xx0x:</b>	Stall Prevention during Deceleration enable
<b>xx1x:</b>	Stall Prevention during Deceleration disable
<b>x0xx:</b>	Stall Prevention during Running enable
<b>x1xx:</b>	Stall Prevention during Running disable
<b>0xxx:</b>	Stall Prevention Decel Time set in ( <b>Fn_02</b> )
<b>1xxx:</b>	Stall Prevention Decel Time set in ( <b>Fn_15</b> )

**Fn\_13: Stall Prevention Level during Accel: 30% - 200%**

**Fn\_14: Stall Prevention Level during Run: 30% - 200%**

**Fn\_15: Stall Prevention Level during Decel: 0.1 – 3600 sec**

### **Note:**

1. If the Acceleration Time in (**Fn\_01**) is set too fast for the size of the load, an Overcurrent Trip “OC-A” may occur during the acceleration period. Setting the proper Stall Prevention Level (**Fn\_13**) during acceleration can automatically extend the ramp time to prevent Overcurrent Trip when acceleration time is too short.
2. If the Deceleration Time in (**Fn\_02**) is set too short, an Overvoltage “OV” condition may occur on the DC BUS. Setting the proper Stall Prevention Level (**Fn\_15**) during deceleration can prevent an “OV” trip when deceleration time is too short.
3. In order to prevent abnormal overload trips during heavy running periods, the Inverter can lower the output frequency in accordance with the Deceleration Time set by (**Fn\_02**) or (**Fn\_15**) when (**Fn\_12**) is (1xxx) or when operational current is over the value set in (**Fn\_14**). The Inverter will return to its normal operating frequency automatically after the current is back to normal conditions.

## Fn\_16: Direct Start / Scanning / Reset Options

- xxx0: Direct Start enable when Remote RUN Command is ON
- xxx1: Direct Start disable when Remote RUN Command is ON
- xx0x: Reset effective only if Remote RUN Command is OFF
- xx1x: Reset effective regardless of the Remote RUN Command condition
- 00xx: **TM2** Terminal will scan 10 times
- 01xx: **TM2** Terminal will scan 5 times
- 10xx: **TM2** Terminal will scan 3 times
- 11xx: **TM2** Terminal will scan once

### Note:

1. When (**Fn\_16**) is set at (xxx1) and the operation mode is set for **TM2** Control (**Fn\_10**), the Inverter cannot start if the RUN switch is ON when the power is engaged. The “STP1” LED will flash. On the Keypad, the RUN switch must be turned OFF and ON again, in order for the Inverter to start.
  
2. Scanning the input signals at **TM2** on Terminals (3) (4) (5) (6) (7) (8) (9) (FWD) (REV) (SP1) (SP2) (SP3) (RESET) are set at (**Fn\_16**). If **TM2** detects the same input signals for the programmed number of times in a row, the Inverter will recognize the signal as a normal signal and execute it.

On the other hand, if **TM2** detects the same input signals that are less than the number of times programmed, **TM2** will ignore the signal. Remark: The scan time is 2ms.

## Preset Speeds and Timer Controls

<b>Fn_17: Preset Speed 1:</b>	<b>0.01Hz ~ 0 - 400Hz</b>
<b>Fn_18: Preset Speed 2:</b>	<b>0.01Hz ~ 0 - 400Hz</b>
<b>Fn_19: Preset Speed 3:</b>	<b>0.01Hz ~ 0 - 400Hz</b>
<b>Fn_20: Preset Speed 4:</b>	<b>0.01Hz ~ 0 - 400Hz</b>
<b>Fn_21: Preset Speed 5:</b>	<b>0.01Hz ~ 0 - 400Hz</b>
<b>Fn_22: Preset Speed 6:</b>	<b>0.01Hz ~ 0 - 400Hz</b>
<b>Fn_23: Preset Speed 7:</b>	<b>0.01Hz ~ 0 - 400Hz</b>

<b>Fn_24: Jog Speed Reference</b>	<b>= 0 - 400Hz</b>
-----------------------------------	--------------------

<b>Fn_25: Master Speed Reference from Keypad</b>	<b>= 0 - 400Hz</b>
--	--------------------

**Note:**

1. The Inverter will operate under the Jog Speed function at **(Fn\_24)**. You can assign either **(Fn\_56)** **(Fn\_57)** or **(Fn\_58)** to handle the Jog function.
2. The Inverter will operate under the Preset Speed frequencies when **(Fn\_56)** **(Fn\_57)** or **(Fn\_58)** are assigned to this function.
3. If the Process Timer **(Fn\_84)** is turned ON and either **(Fn\_56)** **(Fn\_57)** or **(Fn\_58)** has been assigned for input function, and if a pulse signal or contact closure is received on the Multi-Function Input, the Inverter will run at the preset time based on the setting in **(Fn\_85)** **(Fn\_86)** **(Fn\_87)** **(Fn\_88)** **(Fn\_89)** **(Fn\_90)** and **(Fn\_91)**. The sequence will continue until all Process Timers are finished. The Inverter will then return to the frequency set by the Keypad or by the External Speed Pot or jump back to 0 speed to receive the next sequence.
4. A new Speed Setting or Timer Sequence cannot be inserted during an active sequence.

<b>Preset Speed Terminal 8</b>	<b>Preset Speed Terminal 7</b>	<b>Preset Speed Terminal 6</b>	<b>Jog Terminal</b>	<b>Output Frequency (Hz)</b>	<b>Operation Time</b>
X	X	X	X	<b>Fn_25</b>	
X	X	O	X	<b>Fn_17</b>	<b>Fn_85</b>
X	O	X	X	<b>Fn_18</b>	<b>Fn_86</b>
X	O	O	X	<b>Fn_19</b>	<b>Fn_87</b>
O	X	X	X	<b>Fn_20</b>	<b>Fn_88</b>
O	X	O	X	<b>Fn_21</b>	<b>Fn_89</b>
O	O	X	X	<b>Fn_22</b>	<b>Fn_90</b>
O	O	O	X	<b>Fn_23</b>	<b>Fn_91</b>
--	--	--	O	<b>Fn_24</b>	

O: TERMINAL ON

X: TERMINAL OFF

--: NO EFFECT

<b>Fn_26:</b>	<b>Frequency Reference:</b>	<b>0.0 - 400Hz</b>	
<b>Fn_27:</b>	<b>Voltage Reference Offset</b>	<b>0.0 - 100%</b>	
<b>Fn_28:</b>	<b>Voltage Reference Gain</b>	<b>0.0 - 999.9%</b>	
<b>Fn_29:</b>	<b>Positive or Negative Direction</b>	<b>0: Proportional</b>	<b>1: Inverse</b>

Percentage Frequency Setting Signal

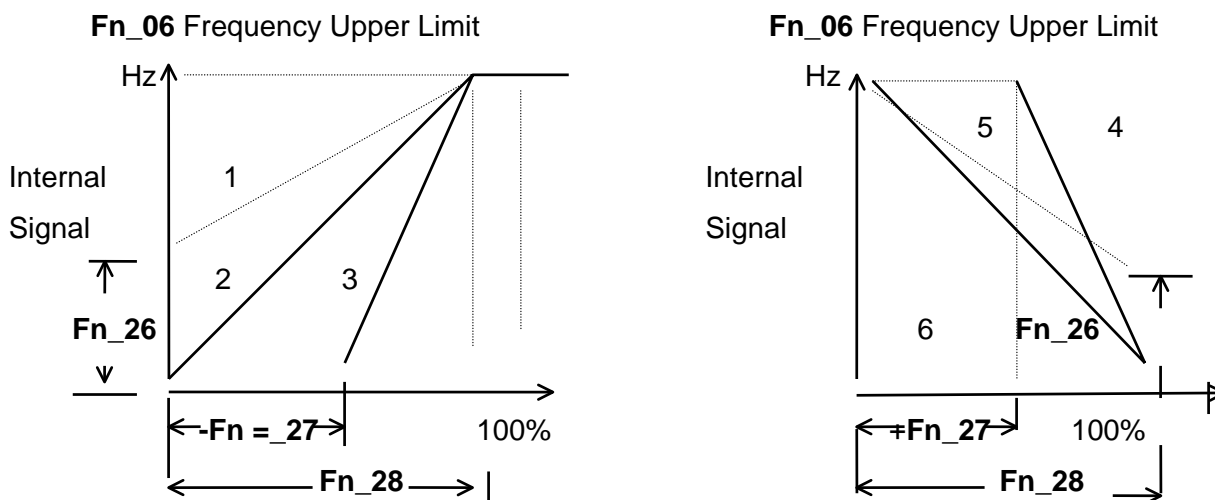

Curves	Fn_26	Fn_27	Fn_28	Fn_29
Curve 1	Set Frequency	Set 0	Set %	0
Curve 2	Set 0	Set 0	Set %	0
Curve 3	Set 0	Set %	Set %	0
Curve 4	Set Frequency	Set 0	Set %	1
Curve 5	Set 0	Set 0	Set %	1
Curve 6	Set 0	Set %	Set %	1

Note: (Fn\_26) (Fn\_27) (Fn\_28) and (Fn\_29) will only work with (Fn\_11) set at 1 or 2.  
(Speed Controlled by Keypad or TM2)

Remarks: Signals from a Voltage Reference on TM2 or the Keypad are 0 - 5VDC. The Analog Input Terminal of TM2 can accept the following signals: 0 - 5VDC, 0 - 10VDC, 0 - 20mA. (Fn\_28) must be greater than (Fn\_27).

<b>Fn_30: Input Voltage of Power Supply Selection</b>	<b>200 - 480 Volts</b>
---	------------------------

<b>Fn_31: Momentary Power Loss Ride Through Time:</b>	<b>.7 - 2 sec</b>				
<b>Fn_32: Power Loss Ride Through</b>	<table border="1"><tr><td><b>xxx0:</b></td><td><b>Disable</b></td></tr><tr><td><b>xxx1:</b></td><td><b>Enable</b></td></tr></table>	<b>xxx0:</b>	<b>Disable</b>	<b>xxx1:</b>	<b>Enable</b>
<b>xxx0:</b>	<b>Disable</b>				
<b>xxx1:</b>	<b>Enable</b>				

1. Inverter will stop when the voltage is lower than the low voltage protection level. The Inverter can restart automatically by using the speed search function.
2. During a Momentary Power Loss, the response time may vary slightly between each model, the response range will be restored accordingly from 0.7 sec to 2 sec.
3. The Inverter will trip after a power disturbance if (**Fn\_32**) is disabled. LV-C will be displayed on the digital Keypad and the Inverter will need to be reset. (**Fn\_34**) (**Fn\_35**) are ineffective.
4. If (**Fn\_32**) is turned ON, the number of Auto Restarts will be transparent if the time of power loss is less than the setting in (**Fn\_31**).

<b>Fn_34: Auto Restart Interval:</b>	<b>0.1 - 800 sec</b>
--------------------------------------	----------------------

<b>Fn_35: Number of Auto Restart Attempts</b>	<b>(0 - 10) Restarts</b>
---	--------------------------

1. In order for Auto Restart to be effective, a value must be assigned to (**Fn\_35**).
2. During Auto Restart, the Inverter will use Speed Search to pull the frequency back to the frequency before the trip from free run status in 0.5 sec and then Accel or Decel to target frequency.
3. Auto Restart is ineffective during the Decel period after a stop command or DC braking.
4. The number of Auto Restarts will be reset under the following conditions:
  - (1). Fault is not detected for 10 minutes (either in Run or Stop Mode).
  - (2). Press "RESET" Key or reset terminal of **TM2**.

<b>Fn_36: Numbers of Motor Poles</b>	<b>= 2 - 8 Poles</b>	<b>(Meters)</b>
--------------------------------------	----------------------	-----------------

<b>Fn_47 = Meter Display Mode</b>		
xxx0:	Output Voltage Display	disable
xxx1:	Output Voltage Display	enable
xx0x:	Bus Voltage Display	disable
xx1x:	Bus Voltage Display	enable
x0xx:	Output Current	disable
x1xx:	Output Current	enable
		(Meters)

<b>Fn_51: Displays Frequency in (Hz); (Preset Frequency) (Operation Frequency)</b>	
0.	Displays Frequency in (Hz)
1.	Displays RPM of Motor; Numbers of Poles set by Fn_36.
2.	Line Speed Display Mode: zero decimal (xxxx)
3.	Line Speed Display Mode: to one decimal place (xxx.x)
4.	Line Speed Display Mode: to two decimal places (xx.xx)
5.	Line Speed Display Mode: to three decimal places (x.xxx) (Meters)

<b>Fn_37: Maximum Frequency</b>	<b>0.01Hz ~ 50 to 400Hz</b>
---------------------------------	-----------------------------

<b>Fn_38: Maximum Voltage Ratio</b>	<b>0.1% ~ 0 to 100%</b>
-------------------------------------	-------------------------

<b>Fn_39: Middle Frequency</b>	<b>0.01Hz ~ 0.11 to 400Hz</b>
--------------------------------	-------------------------------

<b>Fn_40: Middle Voltage</b>	<b>0.1% ~ 0 to 100%</b>
------------------------------	-------------------------

<b>Fn_41: Minimum Voltage Ratio</b>	<b>0.1% ~ 0 to 100%</b>
-------------------------------------	-------------------------

In order to build a Custom V/Hz Pattern, (Fn\_05) must be set at 18.

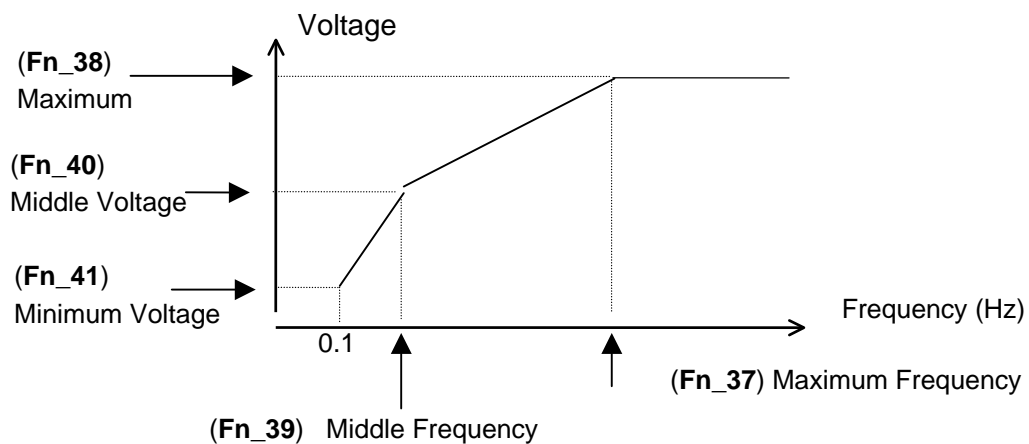

**Fn\_42: Starting Frequency = 0.1 - 10Hz**

The Inverter can start at 5Hz and still have an operational control range of 0.1 - 60Hz. To accomplish this, (Fn\_07) will need to be set at 0Hz and (Fn\_42) at 5Hz.

**Fn\_43: Carrier Frequency = 1 - 12KHz**

Fn_43	Carrier Freq.	Fn_43	Carrier Freq.	Fn_43	Carrier Freq.	Fn_43	Carrier Freq.
0	1KHz	4	2.4KHz	8	4.8KHz	12	8KHz
1	1.2KHz	5	3KHz	9	5KHz	13	9KHz
2	1.8KHz	6	3.6KHz	10	6KHz	14	10KHz
3	2KHz	7	4KHz	11	7.2KHz	15	12KHz

**Fn\_44: Stopping Mode and Brake Resistor Protection**

**xxx0** : Decel to Stop

**xxx1** : Coast to Stop

**xx0x** : Braking Resistor Overheat Protection disable

**xx1x** : Braking Resistor Overheat Protection enable

**Note:**

If (Fn\_44) is set for Coast to Stop, the Inverter will cut off the output after receiving a stop instruction and the motor will coast to a stop.

If (Fn\_44) is set for Decel to Stop, the Inverter will decelerate to the frequency set by (Fn\_54) after receiving deceleration instructions. The output voltage level set at (Fn\_55) the Inverter will stop after the time period set by (Fn\_53).

If (Fn\_44) is set for protection of the Built-in Braking Transistor, and the Inverter decelerates too frequently, the braking transistor and braking resistor may overheat causing the Inverter to trip. (OH1 will be indicated on the Keypad display). The Inverter can be manually restarted after the braking resistor has cooled off. If the braking resistor is damaged and leads to OV-C trip, deceleration time must be increased or the external braking resistor replaced.

**Fn\_45: Multi-Function Adjustment for Analog Output    0 - 200%    (Meters)**

**Fn\_46: Multi-Function Analog Output Meter Selection    0 - 3**

**Meter Scale Factor**

- 0: Output Frequency (Fn\_06 Max.)    10VDC / (Fn\_06)
- 1: Set Frequency (Fn\_06 Max.)    10VDC / (Fn\_06)
- 2: Output Voltage (VAC)    10VDC / (Fn\_30)
- 3: Bus Voltage (10VDC / 450VDC: for 230V Series)  
(10VDC / 900VDC: for 460V Series)

**Fn\_47: Meter Display Mode**

- xxx0: Output Voltage Display    disable
- xxx1: Output Voltage Display    enable
- xx0x: Bus Voltage Display    disable
- xx1x: Bus Voltage Display    enable
- x0xx: Output Current    disable
- x1xx: Output Current    enable    (Meters)

The Display contents can be switched back and forth using the DSPL  
FUNC Key. This can be accomplished in either the RUN or STOP mode.

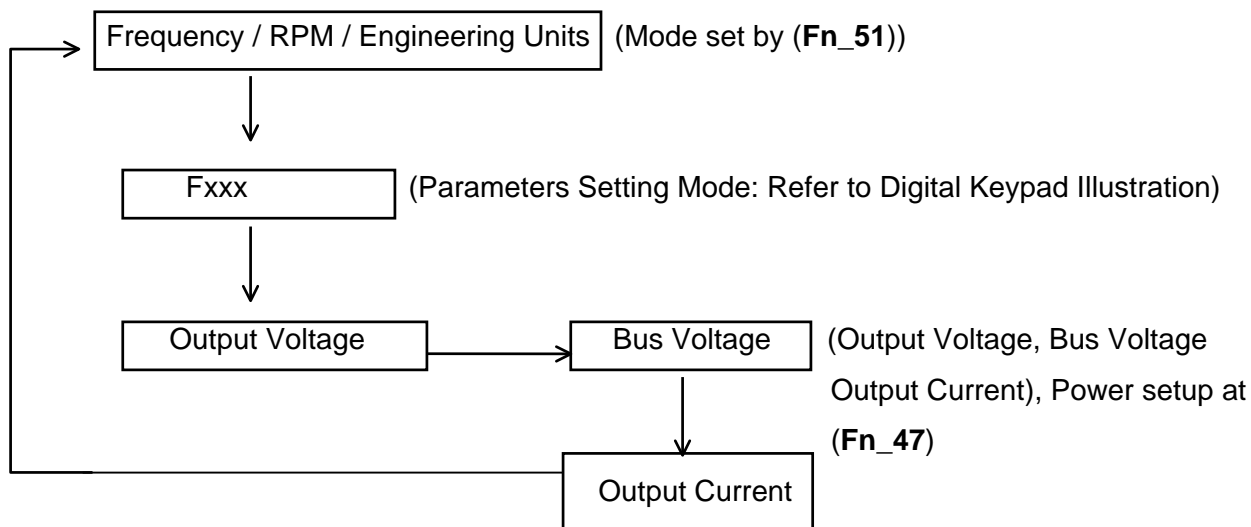

<b>Fn_48: Dynamic Braking, Priority Stopping, Speed Search and AVR Control</b>
--

- |       |
|-------|
| xxx0: |
|-------|

 Enhanced Braking Capacity
- |       |
|-------|
| xxx1: |
|-------|

 Standard Braking Capacity
- |       |
|-------|
| xx0x: |
|-------|

 Stop Key effective in Remote Operation Mode
- |       |
|-------|
| xx1x: |
|-------|

 Stop Key ineffective in Remote Operation Mode
- |       |
|-------|
| x0xx: |
|-------|

 Speed Search controlled by Terminals on **TM2**
- |       |
|-------|
| x1xx: |
|-------|

 Speed Search effective when Inverter Start
- |       |
|-------|
| 0xxx: |
|-------|

 AVR Function effective
- |       |
|-------|
| 1xxx: |
|-------|

 AVR Function ineffective

1. When selecting (**Fn\_48**) for Enhanced Braking Capacity, the inertia of the load can be absorbed by using the Output Voltage Adjustment for deceleration.
2. When selecting (**Fn\_48**) for STOP Key effective in Remote Operation, the “STOP” Key on the Keypad can be used for Emergency Stopping even when using **TM2** for Remote Control Operation. (Stopping mode set by **Fn\_44**). The external switch must be turned OFF and ON again to restart the Inverter.
3. When selecting (**Fn\_48**) for Speed Search from **TM2**, the Speed Search will be effective if the Multi-Function Inputs are used (**Fn\_56**) (**Fn-57**) (**Fn\_58**) (**Fn\_59**) (**Fn\_60**), otherwise the Inverter will start based on Start Frequency (**Fn\_42**).
4. Speed Search will search from preset frequency during operation.

<b>Fn_49: Acceleration Time 2</b>	<b>0.1 ~ 0.1 - 3600 sec</b>
-----------------------------------	-----------------------------

<b>Fn_50: Deceleration Time 2</b>	<b>0.1 ~ 0.1 - 3600 sec</b>
-----------------------------------	-----------------------------

<b>Fn_51: Display Mode Selection</b>	<b>0 - 5</b>
--------------------------------------	--------------

<b>Fn_52: Line Speed Display</b>	<b>1 ~ 0 - 9999</b>
----------------------------------	---------------------

(RPM) =  $\frac{120 \times \text{Frequency}}{\text{Fn}_{36}}$  ; Engineering Units =  $\frac{\text{Frequency} \times \text{Fn}_{52}}{\text{Fn}_{06} \text{ (Fn}_{51} \text{ Display Mode)}}$

<b>Fn_53:</b>	<b>DC Braking Time</b>	<b>0.1 ~ 0 - 25.5 sec</b>
<b>Fn_54:</b>	<b>DC Injection Braking Frequency</b>	<b>0.1 ~ 0.1 - 10Hz</b>
<b>Fn_55:</b>	<b>DC Braking Level</b>	<b>0.1% ~ 0 - 20%</b>
<b>Fn_56 - Fn_60:</b>	<b>DC Braking Level</b>	<b>0.1% ~ 0 - 20%</b>

The application parameters in the Multi-Function Input list are all assignable on **TM2**.

Terminals (6) (7) and (8) are the designated application terminals for the following features:

<b>00:</b>	SP1 (Multi-Speed 1) :	Please refer to <b>(Fn_17)</b>
<b>01:</b>	SP2 (Multi-Speed 2) :	Please refer to <b>(Fn_17)</b>
<b>02:</b>	SP3 (Multi-Speed 3) :	Please refer to <b>(Fn_17)</b>
<b>03:</b>	Jog Operation	Please refer to <b>(Fn_17)</b>
<b>04:</b>	Accel / Decel Time Selection	Please refer to <b>(Fn_01)</b>
<b>05:</b>	External Emergency Stop	
<b>06:</b>	External Base Block Command	
<b>07:</b>	Speed Search:	Please refer to <b>(Fn_48)</b>
<b>08:</b>	Energy Savings Mode:	Please refer to <b>(Fn_82)</b>
<b>19:</b>	Control Signal Selection	
<b>10:</b>	Communication Control Mode Selection	
<b>11:</b>	Accel / Decel Prohibit	
<b>12:</b>	UP Command	
<b>13:</b>	DOWN Command	
<b>14:</b>	Sequence Control:	Please refer to <b>(Fn_17) (Fn_84) - (Fn_91)</b>
<b>15:</b>	Master / Auxiliary Speed Selection:	Please refer to <b>(Fn_11)</b>
<b>16:</b>	(NO - Normally Open Contact) to (NC - Normally Closed Contact)	

Remarks: **(Fn\_56)** will be ineffective when Terminal (6) is used for 3-Wire Control

There are 32 combinations that can be selected as above by

Terminals (6), (7), (8), (21), (22) **(Fn\_56) (Fn\_57) (Fn\_58)**.

### Note:

The Inverter will stop accelerating or decelerating when Accel / Decel Prohibit Signal is activated. When the signal is removed, the Inverter continues accelerating or decelerating.

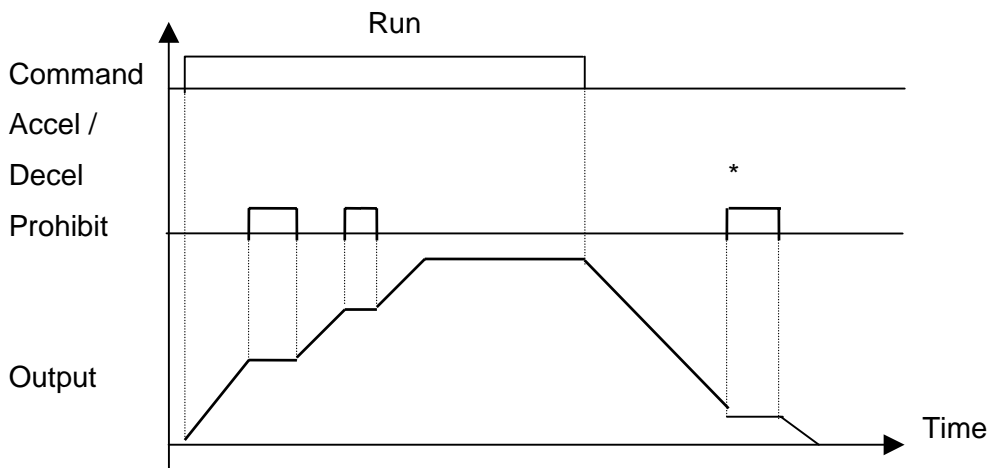

\* : When the "Run" Command is OFF, the Accel and Decel Prohibit Command is inactive.

### External Emergency Stop

As soon as an External Emergency Stop signal is received, the Inverter will Decel to a stop. (Regardless of the setting in **(Fn\_44)**, the display will blink "E.S." After this signal is removed, either turn OFF and ON the RUN Command again to reset. The Inverter will restart from the Start Frequency. If the Emergency Stop Signal is removed before the Inverter stops, the Inverter will still execute the Emergency Stop.

### Fault Contacts are Controlled by **(Fn\_97)**

### External Base Block Command

The Base Block Command can be found in the Multi-Function Input assignment group, (6). As soon as Base Block signal is applied, the Inverter output is shut off regardless of the setting in **(Fn\_44)** and the display will blink "b.b.". After the Base Block input is removed, either turn OFF and ON again Run Command, or press the RUN Key and the Inverter will restart from the Start Frequency.

## UP / DOWN Command

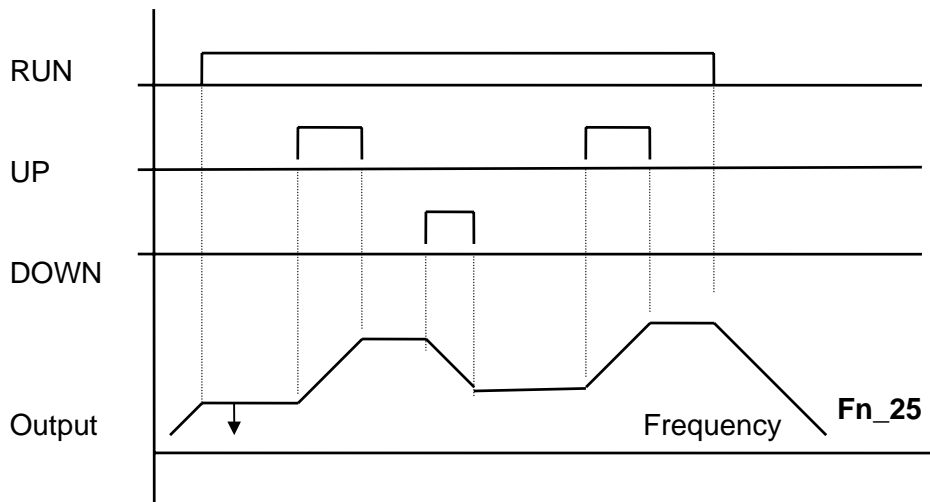

To utilize the Up and Down function, (**Fn\_11**) must be set to terminal control.

When using this function, set (**Fn\_03**) to the (0xxx) position. The Inverter will accelerate to the Target Frequency set at (**Fn\_25**) after the designated terminal is turned ON. The drive will remain at what ever speed it was at when the contact terminal was released.

When the (UP) or (DOWN) terminal is engaged, the Inverter starts accelerating or decelerating. When the UP or DOWN signal disappears, the Inverter will stay at the current frequency. Once the operating signal is OFF, the Inverter will decelerate to a stop or stop immediately (decided by (**Fn\_44**)), the operation frequency will be recorded in (**Fn\_25**).

Terminal UP or DOWN control is inactive during the stop mode. The Target Frequency must be changed at (**Fn\_25**) through the Keypad.

## Fn\_61: Multi-Function Output: Terminals 10 / 11

- 00: Run Mode
- 01: At Target Speed
- 02: Set Frequency (**Fn\_08**) (**Fn\_09**)
- 03: Frequency Detection (**Fn\_08**) 1
- 04: Frequency Detection (**Fn\_08**) 2
- 05: Overcurrent Detection
- 06: Change From NO to NC Contact

<b>Fn_65: Skip Frequency 1</b>	<b>0.01Hz ~ 0 - 400Hz</b>
--------------------------------	---------------------------

<b>Fn_66: Skip Frequency 2</b>	<b>0.01Hz ~ 0 - 400Hz</b>
--------------------------------	---------------------------

<b>Fn_67: Skip Frequency 3</b>	<b>0.01Hz ~ 0 - 400Hz</b>
--------------------------------	---------------------------

<b>Fn_68: Frequency Band Width</b>	<b>0.01Hz ~ 0 - 10Hz</b>
------------------------------------	--------------------------

**Example:**

When (**Fn\_65**) is set at 10.0Hz, (**Fn\_66**) is set at 20.0Hz, (**Fn\_67**) is at 30.0Hz, (**Fn\_68**) Skip bandwidth at 2.0Hz

The Skip Frequency Ranges are:

10Hz ± 2Hz = 8 - 12Hz
20Hz ± 2Hz = 18 - 22Hz
30Hz ± 2Hz = 28 - 32Hz

<b>Fn_69: Electronic Overload Protection</b>
--

- xxx0:** Electronic Thermal Motor Protection activated
- xxx1:** Electronic Thermal Motor Protection deactivated
- xx0x:** Electronic Thermal characteristics in accordance with Standard Motor
- xx1x:** Electronic Thermal characteristics in accordance with Special Motor
- x0xx:** Motor Protection OL: 103% continuous, 150% for 60 seconds
- x1xx:** Motor Protection OL: 113% continuous, 123% for 60 seconds
- 0xxx:** Coast to Stop after Electronic Thermal Motor Protection is energized
- 1xxx:** Operation continued after Electronic Thermal Motor Protection is energized

<b>Fn_70: Motor Rated Current</b>	<b>(- - - -)</b>
-----------------------------------	------------------

The motors Rated Nameplate Current must be entered in function (**Fn\_70**) for proper thermal protection.

**Constant Torque Loads.** When the motors output current exceeds 103% of the motors protective electronic thermal characteristics during the start operation, the Inverters protective (OL1) will allow operation of the drive for 150% of rated current for 60 seconds before shutting the Inverters output off.

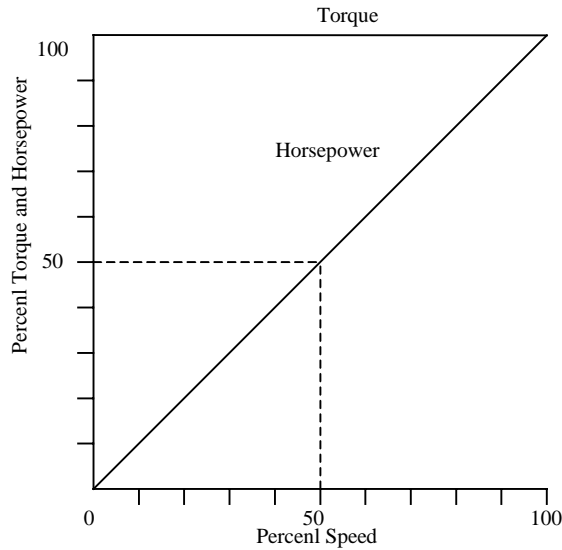

Constant Torque Loads:

With a Constant Torque Load, the torque loading is not a function of speed. This is a characteristic of traction drives, conveyors, positive displacement pumps, etc.

As the speed changes, the load torque will remain constant and the horsepower will change linearly with the speed.

**Variable Torque Loads (Fans, Pumps...etc.)** When the motors output current exceeds 113% of the motor’s protective electronic thermal characteristics during the start operation, the Inverters protective (OL1) will allow the drive to operate at 123% for 60 seconds before shutting the Inverters output off.

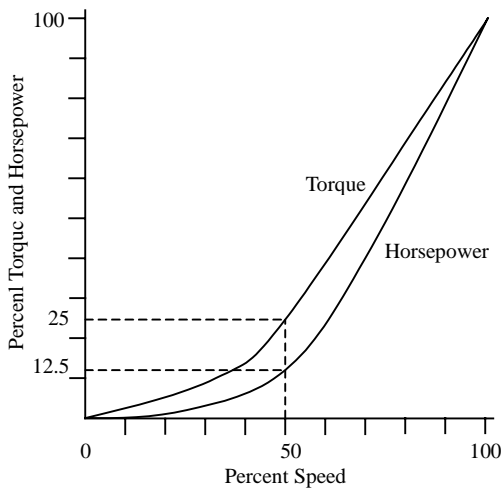

Variable Torque Loads:

With a Variable Torque Load, torque loading is a function of speed. This is characteristic of centrifugal pumps, and certain types of fans and blowers. As the speed is increased, typically the torque will increase with the square of the speed and the horsepower will increase with the cube of the speed.

During operational conditions where the motor must run at low speeds, it's important to pay attention to the motors' capacity to dissipate heat. Most motors are designed to cool themselves at 60Hz and full voltage. Proper setup of the thermal functions should be observed.

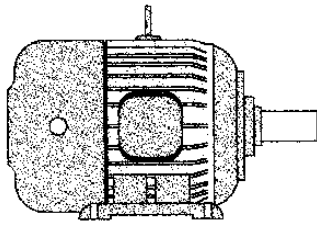

The motor's ability to cool itself is dependent of its on board fan. Low speeds and high currents can reduce the life of the motor. Use the Inverter's thermal protections and setup features to help with these types of situations.

When the Electronic Thermal Motor Protection is ON in (Fn\_69) during an overload condition, the Inverter will continue running while displaying a blinking "OL1". The blinking "OL1" will continue until the running current is lower than 103% or 113% (depending on the setting in (Fn\_69).

**The functions of the Electronic Thermal Inverter Protection are as follows:**

**The Inverter will continue to run when the current is under 110%. If the inverter continues above 110%, the Inverter will time out proportionally to 150% at 60 seconds.**

In (Fn\_71), if the setting is (xxx0) after the Electronic Thermal Inverter Protection is energized, the Inverter Base Block immediately shuts down the drive and a "OL2" is displayed on the Keypad.

**To Restart the Inverter, it is necessary to press the RESET Key**

In (Fn\_71), if the setting is (xxx1) after the Electronic Thermal Inverter Protection is energized, the Inverter will continue to run and display a blinking "OL2" until the current is lower than 110% of the rating.

Setup & Derating

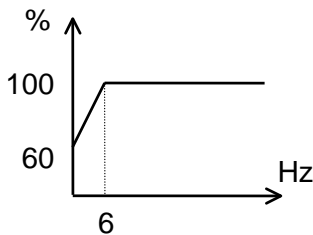

(Fn\_69) is (xx1x)

Special Motor

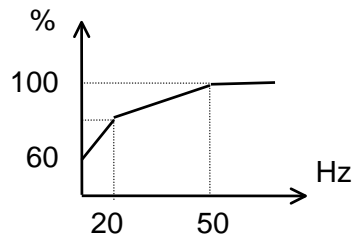

(Fn\_69) is (xx0x)

(Fn\_05) is (0-8)

50Hz Standard Motor

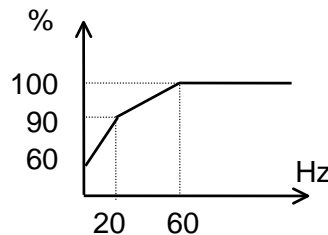

(Fn\_69) is (xx0x)

(Fn\_05) is (9-17)

60Hz Standard Motor

**Fn\_71: Torque Boost**

- x0xx:** Torque Boost enable
- x1xx:** Torque Boost disable
- 1xxx:** Manual Torque Boost

**Fn\_72: Torque Boost Gain: 0.0 to 10.0%****Note:**

In (**Fn\_71**), when using the setting (x1xx), both Auto and Manual Torque Boost are inactive.

When using the setting (0xxx), the Inverter adjusts the Torque Boost by automatically adjusting to the Inverters output current.

When using the setting (1xxx), the Torque Boost is adjusted according to the settings in V/F pattern (**Fn\_05**) and (**Fn\_72**).

**Fn\_75: Motor No Load Current**      - - - - -**Fn\_76: Motor Rated Slip: 0.0 - 6.00Hz****Fn\_77: Overtorque Control**

- xxx0:** Overtorque Detection disable
- xxx1:** Overtorque Detection enable
- xx0x:** Enable only if at Set Frequency
- xx1x:** Enable during Operation
- x0xx:** Operation continued after Overtorque is detected
- x1xx:** Coast to Stop after Overtorque is detected

<b>Fn_78: Overtorque Detection Level:</b>	<b>30 - 200%</b>
---	------------------

<b>Fn_79: Overtorque Detection Time:</b>	<b>0 - 25 sec</b>
--	-------------------

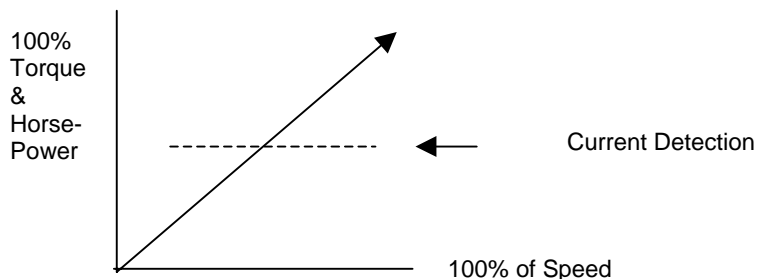

1. An Overtorque condition exists when the output current (rated current is 100%) remains above Overtorque Detection Level (**Fn\_78**) for a period greater than the Overtorque Detection Time (**Fn\_79**).
2. When Overtorque occurs and (**Fn\_77**) is set to (x0xx), the Inverter continues to run and displays a blinking “OL3” light until the output current is lower than the (**Fn\_78**) setting.  
When Overtorque occurs and (**Fn\_77**) is set to (x1xx), the Inverter Base Blocks immediately and the display blinks “OL3”. To restart the Inverter, press RESET key.
3. When (**Fn\_61**) (**Fn\_62**) or (**Fn\_63**) (Multi-Function Output Terminal Control) is set to 05, the Multi-Function Output provides an Overtorque Detection Signal. The Overtorque Detection Output signal is available if (**Fn\_77**) is set to (xxx1).

**Fn\_80: S-Curve Setup: Time (1) Acceleration & Deceleration: 0 - 4 sec**

**Fn\_81: S-Curve Setup: Time (1) or (2) Acceleration & Deceleration: 0 - 4 sec**

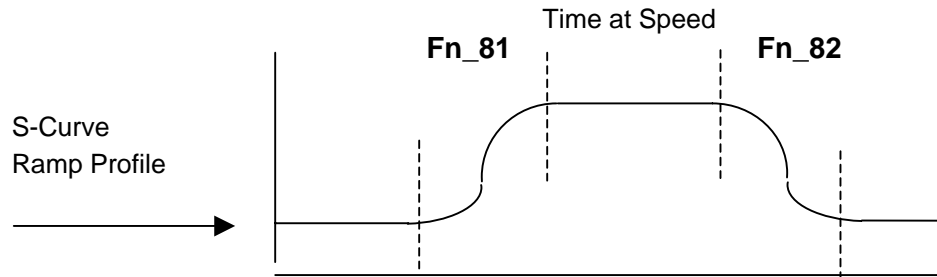

Formula for Calculating Acceleration and Deceleration Time.

$$\text{Accel Time} = (\mathbf{Fn\_01}) \text{ or } (\mathbf{Fn\_49}) \times \frac{\text{Preset Frequency}}{60 \text{ Hz}}$$

$$\text{Decel Time} = (\mathbf{Fn\_02}) \text{ or } (\mathbf{Fn\_50}) \times \frac{\text{Preset Frequency}}{60 \text{ Hz}}$$

**Note:**

1. Accel & Decel S-Curves (1 or 2) can be selected by using the Multi-Functional Input Terminals along with the programming of (**Fn\_56**) (**Fn\_57**) or (**Fn\_58** to (4)).
2. The S-Curve function is disabled when (**Fn\_80**) (**Fn\_81**) are set to (0).
3. The S-Curve Ramp pattern will reflect the ramp pattern above if the S-Curve time in (**Fn\_80**) (**Fn\_81**) are greater than (0).
4. Total actual Accel and Decel times are calculated by adding the actual Accel (**Fn\_01**) and (**Fn\_02**) Decel times with the S-Curve time.

## Fn\_82: Energy Savings

xx00: Energy Savings disable

xx01: Energy Savings controlled by Multi-Function Input Terminals using Preset Speed functions.

## Fn\_83: Energy Savings Gain: 0 - 100%

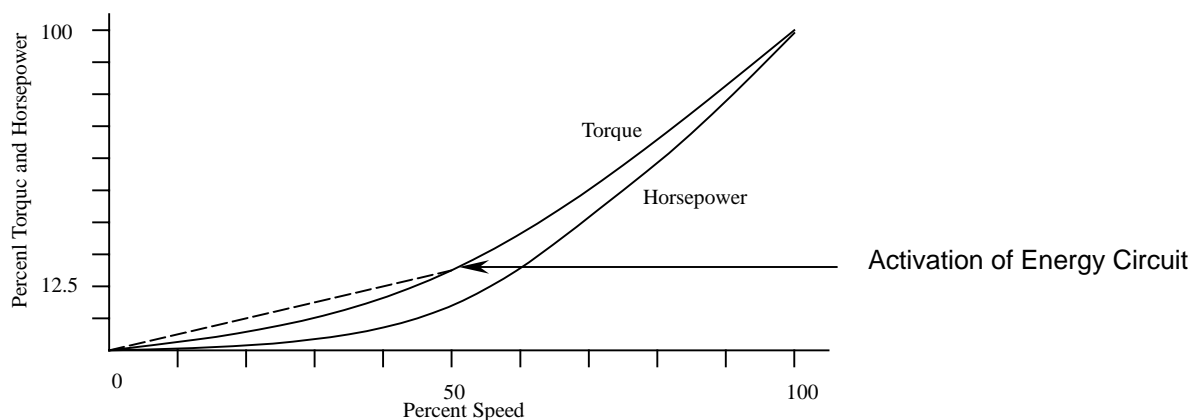

1. This function can be applied to Fans or Pumps that have loads with high starting inertias. In these types of applications, where the load is heavy during start-up but tapers off to a variable torque type load at some point in the ramp curve, using function (Fn\_83) to adjust the suitable gain (voltage level) at the target speed will reduce the V/Hz ratio saving energy.
2. The Energy Savings function is available only if (Fn\_56) (Fn\_57) or (Fn\_58) Multi-Function Inputs are set to (08) or (24).
3. When the Multi-Function Input Terminal is turned ON, and (Fn\_82) is set to (xx01) and (Fn\_56) (Fn\_57) or (Fn\_58) are set to (08), the output voltage will decrease gradually to the previous output voltage x (Fn\_83). When the input terminal is turned OFF, the output voltage will gradually increase to the previous voltage.

**Fn\_84: Sequence Control**

- xxx0:** Process Timer disabled
- xxx1:** Process Timer enabled
- xx0x:** Set Frequency Output after Process Timer ends count
- xx1x:** Zero Speed Output after Process Timer ends count
- xx1x:** Process Sequence Auto Repeat

SP1	SP2	SP3	Frequency output
OFF	OFF	OFF	Set by external signal or Digital operator control ①
ON	OFF	OFF	Frequency of Fn_17 ②
OFF	ON	OFF	Frequency of Fn_18 ③
ON	ON	OFF	Frequency of Fn_19 ④
OFF	OFF	ON	Frequency of Fn_20 ⑤
ON	OFF	ON	Frequency of Fn_21 ⑥
OFF	ON	ON	Frequency of Fn_22 ⑦
ON	ON	ON	Frequency of Fn_23 ⑧

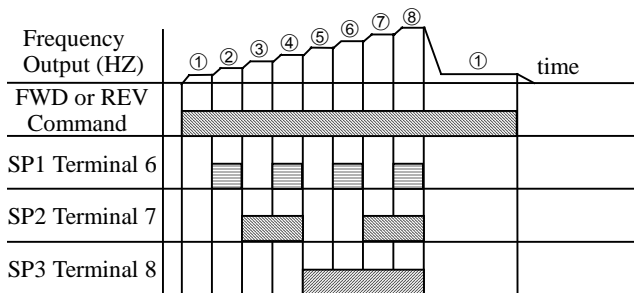

**Note:**

If **(Fn\_84)** is set to (xxx1) and **(Fn\_56)** **(Fn\_57)** and **(Fn\_58)** are set to (0) (1) or (2) when the contact pulse is closed on one of the designated terminals the drive will run for the programmed amount of time set in **(Fn\_85)** through **(Fn\_91)** and at a the programmed frequency set in **(Fn\_17)** through **(Fn\_23)**. At the end of the sequence if there is no other command, the Inverter will resume its frequency command by the Keypad, Remote Speed Pot, or back to **(Fn\_84)**.

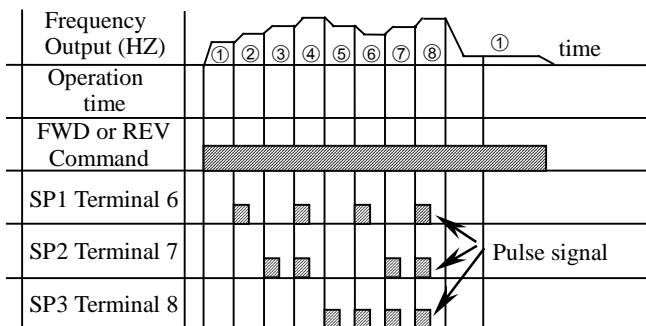

For Process Sequence Control, use the Process Timers and the Preset Speed functions.  
**(Fn\_85)** Through **(Fn\_91)**  
**(Fn\_17)** Through **(Fn\_23)**

**Note:**

When **(Fn\_84)** is set to (xxx0), the Inverter will operated under the Multi-Speed Frequency when **(Fn\_56)** **(Fn\_57)** and **Fn\_58** are set to (0) (1) or (2).

<b>Fn_85:</b>	<b>Process Timer:</b>	<b>1</b>	<b>0.1 sec ~ 0 - 3600 sec</b>
<b>Fn_86:</b>	<b>Process Timer:</b>	<b>2</b>	<b>0.1 sec ~ 0 - 3600 sec</b>
<b>Fn_87:</b>	<b>Process Timer:</b>	<b>3</b>	<b>0.1 sec ~ 0 - 3600 sec</b>
<b>Fn_88:</b>	<b>Process Timer:</b>	<b>4</b>	<b>0.1 sec ~ 0 - 3600 sec</b>
<b>Fn_89:</b>	<b>Process Timer:</b>	<b>5</b>	<b>0.1 sec ~ 0 - 3600 sec</b>
<b>Fn_90:</b>	<b>Process Timer:</b>	<b>6</b>	<b>0.1 sec ~ 0 - 3600 sec</b>
<b>Fn_91:</b>	<b>Process Timer:</b>	<b>7</b>	<b>0.1 sec ~ 0 - 3600 sec</b>
<b>Fn_92:</b>	<b>Vibration Control Time:</b>		<b>1 - 100</b>
<b>Fn_93:</b>	<b>Vibration Prevention Gain:</b>		<b>0 - 100%</b>
<b>Fn_94:</b>	<b>Vibration Prevention Bias:</b>		<b>0 - 30%</b>

**Note:**

1. Adjusting (**Fn\_92**) (unit = 2 ms) to 1/4 of machine's vibration cycle can provide the optimal performance.
2. Adjusting (**Fn\_93**) according to the amplitude of vibration can reduce vibration to a minimum.

<b>Fn_95:</b>	<b>Factory Adjustments only</b>
<b>Fn_96:</b>	<b>Factory Adjustments only</b>

**Fn\_97: Fault Control Setup**

- xxx0: Fault Contact is Not energized during Auto Restart Operation
- xxx1: Fault Contact is energized during Auto Restart Operation
- xx0x: Fault Contact is Not energized during Momentary Power Loss Detection
- xx1x: Fault Contact is energized during Momentary Power Loss Detection
- x0xx: Fault Contact is Not energized after External Emergency Stop signal is received
- x1xx: Fault Contact is energized after External Emergency Stop signal is received
- 0xxx: Fault Contact is Not energized during External Base Block
- 1xxx: Fault Contact is energized during External Base Block

**Fn\_98: Fault Contact Setup**

- xxx0: Fault Contact is Not energized after Overtorque (OL3) is detected
- xxx1: Fault Contact is energized after Overtorque (OL3) is detected
- xx0x: Fault Contact is Not energized after Electronic Overload (OL1) is activated
- xx1x: Fault Contact is energized after Electronic Overload (OL1) is activated
- x0xx: Fault Contact is Normally Open (NO)
- x1xx: Fault Contact is Normally Closed (NC)
- 0xxx: Fault Contact is Not energized after Electronic Overload (OL2) is activated
- 1xxx: Fault Contact is energized after Electronic Overload (OL2) is activated

**Note:**

If (**Fn\_97**) is set to (xxx0). During the Auto Restart operation, the fault contact will not be energized until (**Fn\_35** (Auto Restart Times) decreases to 0. (OL1 / OL2 / OL3)

**Fn\_100: Communication Address: 1 ~ 32****Fn\_101: Baud Rate of Communication: (bps)**

- 0: = 4800
- 1: = 9600
- 2: = 19200
- 3: = 38400

## Fn\_102: Communication Parameters

xxx0:	1 Stop Bit
xx0x:	Even Parity
x0xx:	Without Parity
0xxx:	8 Bits Data
xxx1:	2 Stop Bits
xx1x:	Odd Parity
x1xx:	With Parity
1xxx:	7 Bits Data

Note:

### To use RS-485, the optional RS-485 Interface Card is required.

- For one to one control: Using a PC, PLC or some sort of control device to control one drive, set (**Fn\_100**) to (1).
- When controlling multiple Inverters using a PC, PLC or some sort of control device to control multiple Inverters, set up (**Fn\_100**) according to the number of Inverters you are controlling. Each number will identify and be used as the address for the Inverters identification and parameter setup change.
- Up to 32 Inverters can be controlled simultaneously using the communication interface function.
- If the PC sends the code 33 to the Inverters, all linked Inverters (up to 32) can be controlled simultaneously. All receiving the same signal or parameter change.

**To use RS-232 Communications, the optional RS-232 Interface Card is required.**

- a. For one to one control: Using a PC, PLC or some sort of control device to control one Inverter, set (**Fn\_100**) to (1).
- b. An ASCII CODE is used for FM100 communication.
- c. (**Fn\_10**) and (**Fn\_11**) will be ineffective for Inverter operation and frequency control while in the communication mode.
- d. The frequency signals Upper and Lower Limits are controlled by (**Fn\_06**) (**Fn\_07**) while in the communication mode.
- e. The PC will request data from the Inverter automatically to obtain information on the (STATUS\_LED, VAC, VPN, IAC, Frequency, RPM).
- f. The Inverter will confirm the validity of the new parameters when set by the PC.
- g. Please refer to the RS-232 and RS-485 communications manual for detailed function and protocol information.

**Fn\_123: Default to Factory Settings**

(1111) Returns Drive to Factory Settings for 60Hz operation:

(1110) Returns Drive to Factory Settings for 50Hz operation:

**Fn\_124: CPU Software Version**

**Fn\_125: Fault Log:**

**Last 3 Faults**

In order to simplify any troubleshooting, the Inverter records the last three fault codes automatically in its EEPROM memory. Press the Up & Down arrows on the Keypad to review the recorded faults.

**Sample:**

- 1. (LV-C) The first fault code. The latest is Low Voltage.
- 2. (OC-d) Overcurrent during deceleration.
- 3. (- - -) No Fault Recorded. Only two faults occurred.

**Failure Indication:****Faults which cannot be reset by Manual Operation:**

<b>Fault Code</b>	<b>Content</b>	<b>Probable Cause</b>	<b>Action Item</b>
CPF	CPU Software Error	1. Excessive electrical noise	1. Install RC type suppresser on all contactor / brake coils
EPR	EEPROM Error	1. EEPROM is damaged	1. Change EEPROM
- OV -	Overvoltage in Stop Mode	1. Detection circuit is damaged	1. Contact factory
- LV -	Low Voltage in Stop Mode	1. Input voltage is too low 2. Current limit resistor (R1) or fuse burned out - 460V Series 3. Detection circuit is damaged	1. Correct input voltage 2. Change current limit resistor or fuse 3. Contact factory
- OH -	Heatsink Over-Heat in Stop Mode	1. Detection circuit is damaged 2. Ambient temperature is too high or ventilation is poor	1. Contact factory 2. Lower ambient temperature or improve ventilation
OH1*	Braking Resistor Overload	1. Decel Time is too short 2. Frequent RUN / STOP operation 3. Excessive load	1. Increase Decel Time 2. Increase RUN / STOP cycle 3. Set <b>Fn_44</b> to xx0x and increase resistance of braking resistor

When the braking resistor is overloaded during deceleration, the Inverter will stop braking and display “OH1”. When the heat is dissipated, the “OH1” will disappear and the Inverter will start braking again.

**Faults which can be Auto-Reset by Manual Operation:**

<b>Fault Code</b>	<b>Content</b>	<b>Probable Cause</b>	<b>Action Item</b>
OC-S	Overcurrent during Starting	<ol style="list-style-type: none"> <li>1. Motor is short circuited</li> <li>2. Motor has ground fault</li> <li>3. Inverter transistor module is damaged</li> </ol>	<ol style="list-style-type: none"> <li>1. Check and fix motor</li> <li>2. Remove the grounding point</li> <li>3. Change transistor module</li> </ol>
OC-A	Overcurrent during Accel.	<ol style="list-style-type: none"> <li>1. Accel Time is set too short</li> <li>2. Inappropriate V/F pattern selection</li> <li>3. Motor capacity exceeds the Inverter rating</li> </ol>	<ol style="list-style-type: none"> <li>1. Extend Accel Time</li> <li>2. Select the optimum V/F pattern</li> <li>3. Select an Inverter with larger HP</li> </ol>
OC-C	Overcurrent during Constant Speed	<ol style="list-style-type: none"> <li>1. Load changes excessively</li> <li>2. Input voltage fluctuates excessively</li> </ol>	<ol style="list-style-type: none"> <li>1. Check load condition</li> <li>2. Install a reactor between power supply and Inverter</li> </ol>
OC-d	Overcurrent during Decel	<ol style="list-style-type: none"> <li>1. Decel Time is set too short</li> </ol>	<ol style="list-style-type: none"> <li>1. Extend Decel Time</li> </ol>
OC-b	Overcurrent during Braking	<ol style="list-style-type: none"> <li>1. Braking frequency is set too high</li> <li>2. Braking voltage is set too high</li> <li>3. Braking time is set too long</li> </ol>	<ol style="list-style-type: none"> <li>1. Reduce braking frequency</li> <li>2. Lower braking voltage</li> <li>3. Shorten braking time</li> </ol>
OV-C	Overvoltage during Constant Speed	<ol style="list-style-type: none"> <li>1. Decel Time is set too short or load inertia is too high</li> <li>2. Input voltage fluctuates</li> </ol>	<ol style="list-style-type: none"> <li>1. Extend Decel Time</li> <li>2. Set <b>Fn_48</b> = xxx0</li> <li>3. Add external braking resistor or module</li> <li>4. Install a reactor between power supply and Inverter</li> <li>5. Select an Inverter with larger HP</li> </ol>

LV-C	Low Voltage during Constant Speed	<ol style="list-style-type: none"> <li>1. Input voltage is too low</li> <li>2. Input voltage fluctuates excessively</li> </ol>	<ol style="list-style-type: none"> <li>1. Correct input voltage or extend <b>Fn_31</b></li> <li>2. Extend Accel Time</li> <li>3. Select an Inverter with larger HP</li> <li>4. Install a reactor between power supply and Inverter</li> </ol>
OH-C	Overheat during Constant speed	<ol style="list-style-type: none"> <li>1. Load is too high</li> <li>2. Ambient temperature is too high or ventilation is poor</li> </ol>	<ol style="list-style-type: none"> <li>1. Investigate load condition</li> <li>2. Select an Inverter with larger HP</li> <li>3. Lower ambient temperature or improve ventilation</li> </ol>
OH1	Braking Resistor Overload	<ol style="list-style-type: none"> <li>1. Decel Time is too short</li> <li>2. Frequent Run / Stop operation</li> <li>3. Load is too high</li> </ol>	<ol style="list-style-type: none"> <li>1. Increase Decel Time.</li> <li>2. Increase Run / Stop cycle</li> <li>3. Set <b>Fn_44</b> to xx0x and increase resistance of braking resistor</li> </ol>

**Faults which can be Reset by Manual Operation, but cannot be Auto-Reset :**

<b>Fault Code</b>	<b>Content</b>	<b>Probable Cause</b>	<b>Action Item</b>
- OC -	Overcurrent during Stop Mode	<ol style="list-style-type: none"> <li>1. Detecting circuit failure</li> <li>2. CT Signal cable failure</li> </ol>	<ol style="list-style-type: none"> <li>1. Send Inverter back to factory for repair</li> </ol>
OL1	Motor Overload	<ol style="list-style-type: none"> <li>1. Load is too high</li> <li>2. Inappropriate V/F pattern selection</li> <li>3. Incorrect <b>Fn_69, Fn_70</b> setting</li> </ol>	<ol style="list-style-type: none"> <li>1. Select an Inverter with larger HP</li> <li>2. Select optimum V/F pattern</li> <li>3. Select correct <b>Fn_69 &amp; Fn_70</b> setting</li> </ol>
OL2	Inverter Overload	<ol style="list-style-type: none"> <li>1. Load is too high</li> <li>2. Inappropriate V/F pattern selection</li> </ol>	<ol style="list-style-type: none"> <li>1. Select a larger HP Inverter</li> <li>2. Select optimum V/F pattern</li> </ol>
OL3	Overtorque	<ol style="list-style-type: none"> <li>1. Load is too high</li> <li>2. Inappropriate V/F pattern selection</li> <li>3. <b>Fn_78, Fn_79</b> are set too low</li> </ol>	<ol style="list-style-type: none"> <li>1. Select a larger HP Inverter</li> <li>2. Select optimum V/F pattern selection</li> <li>3. Select appropriate <b>Fn_78 &amp; Fn_79</b> settings</li> </ol>

## Special Condition Indication

Fault Code	Content	Illustration
STP0	Zero Speed Stop	<p>1. <b>Fn_11</b> = 0 or 3, <b>Fn_07</b> &lt; 0.1Hz, and setting freq.&lt; 0.1Hz;  <b>Fn_11</b> = 1 or 23, <b>Fn_07</b> &lt; (<b>Fn_06</b> / 100), and setting freq. &lt; 0.1Hz</p>
STP1	Direct Start disable	<p>1. Power switched on while remote RUN switched ON (<b>Fn_10</b>)  Direct Start is prohibited (<b>Fn_16</b>= xxx1). Inverter can not be started and will display STP1. (Refer to <b>Fn_16</b>)  Inverter can be started directly when <b>Fn_16</b> = xxx0.</p>
STP2	Emergency Stop Command by STOP Key	<p>1. Emergency Stop via Digital Keypad in remote control mode (<b>Fn_10</b> = 1) by pressing STOP key (<b>Fn_48</b> = xx0x). Once STOP key is pressed during operation, Inverter will stop according to the setting of <b>Fn_44</b> and display STP2. Inverter will not restart until power is turned OFF and ON again.</p> <p>2. If the Inverter is under communications control and <b>FN_48</b> = xx0x, Once STOP key is pressed, Inverter will stop according to the setting of <b>Fn_44</b> and display STP2. Inverter will not restart until computer sends Stop command followed by a RUN command.</p> <p>3. STOP key cannot be used for Emergency Stop when <b>Fn_48</b>=xx1x.</p>
E.S.	Emergency Stop Command by Remote Control	<p>1. Emergency stop via remote control mode (Multi-Function Input terminals), The Inverter will decelerate to stop and display E.S.</p>
b.b.	External Base Block	<p>External signal Base Blocks Inverter via Multi-Function Input Terminals (please refer to <b>Fn_56-60</b>).</p>

**Digital Keypad Operation Failure Indication:**

<b>Fault Code</b>	<b>Content</b>	<b>Probable Cause</b>	<b>What to do</b>
LOC	Parameter / Freq. / REV Direction Lock	<ol style="list-style-type: none"> <li>1. Attempt to change parameter / freq. When Fn_04 = xxx1 or xx1x</li> <li>2. Attempt to RUN in REV direction when Fn_03 = x1xx</li> </ol>	<ol style="list-style-type: none"> <li>1. Set Fn_04 = xxx0 or xx0x</li> <li>2. Set Fn_03 = x0xx</li> </ol>
Err1	Operation Error	<ol style="list-style-type: none"> <li>1. Attempt to change freq. by pressing <math>\wedge</math> or <math>\vee</math> when Fn_11 &gt; 0</li> <li>2. Attempt to change Fn_124</li> <li>3. Attempt to change functions which cannot be changed during operation</li> </ol>	<ol style="list-style-type: none"> <li>1. Set Fn_11 = 0</li> <li>2. Fn_124 (CPU version) cannot be changed</li> <li>3. Change functions in stop mode</li> </ol>
Err2	Setting Error	<ol style="list-style-type: none"> <li>1. Fn_07 is in the range of Fn_65 <math>\pm</math> Fn_68, Fn_66 <math>\pm</math> Fn_68 or Fn_67 <math>\pm</math> Fn_68</li> <li>2. Fn_06 <math>\leq</math> Fn_07</li> <li>3. Fn_70 <math>\leq</math> Fn_75</li> <li>4. Fn_27 <math>\geq</math> Fn_28</li> </ol>	<ol style="list-style-type: none"> <li>1. Adjust Fn_65 - Fn_68 or Fn_07 setting</li> <li>2. Fn_06 &gt; Fn_07</li> <li>3. Fn_70 &gt; Fn_75</li> <li>4. Fn_27 &lt; Fn_28</li> </ol>
Err3	Setting Error	<ol style="list-style-type: none"> <li>1. V/F curve is set too steep when Fn_05 = 18</li> <li>2. Analog freq. signal is set too steep</li> </ol>	<ol style="list-style-type: none"> <li>1. (Fn_38 - Fn_40) / (Fn_37 - Fn_39) <math>\leq</math> 65, (Fn_40 - Fn_41) / (Fn_39 - 0.1) <math>\leq</math> 65</li> </ol>
Err4	Setting Error	<ol style="list-style-type: none"> <li>1. Incorrect settings of Fn_37 - Fn_41</li> </ol>	<ol style="list-style-type: none"> <li>1. Fn_37 &gt; Fn_39 &gt; 0.1 Hz Fn_38 <math>\geq</math> Fn_40 <math>\geq</math> Fn_41</li> </ol>
Err5	Parameters Setting Error	<ol style="list-style-type: none"> <li>1. Under disable condition</li> <li>2. Amend Fn_101 or Fn_102 during communication</li> </ol>	<ol style="list-style-type: none"> <li>1. Set enable before communication Fn_101, Fn_102 should be amended before communication.</li> </ol>
Err6	Communication Error	<ol style="list-style-type: none"> <li>1. Connection error</li> <li>2. Improper parameters</li> <li>3. Checksum error</li> <li>4. Agreement error</li> </ol>	<ol style="list-style-type: none"> <li>1. Investigate connection</li> <li>2. Check Fn_101, Fn_102</li> <li>3. Check communication agreement</li> <li>4. Check communication</li> </ol>

Err7	Parameter Setting Error	1. Attempt to change <b>Fn_00</b> or <b>Fn_96</b> 2. The value in <b>Fn_96</b> is far from the value of detected voltage	1. Refer to 2.3 “Changing control boards” 2. Check PN voltage circuit
------	----------------------------	---	---

### Maintenance Section:

This Inverter requires few routine checks. It will function efficiently and its normal operational lifetime will be longer if it is kept clean, cool and dry. Periodically check the Inverter for tightness of electrical connections, discoloration or other signs of overheating. ***During service inspection, turn off the AC main circuit power and wait for the charging indicator LED 101 to extinguish (for at least 10 minutes) before touching any circuit components. Failure to adhere to this warning could result in serious or lethal injuries.***

- (1) Clean up internal dust and dirt
- (2) Check for tightness of electrical connection.
- (3) Perform Meg test
  - (a) Remove all connection wires from the complete unit when performing Meg test.
  - (b) Meg test only can be applied on main circuit.

**NOTE!!** Never perform Meg test on control circuit.

The insulation resistance of DC-500V tester should be more than 5M ohm.

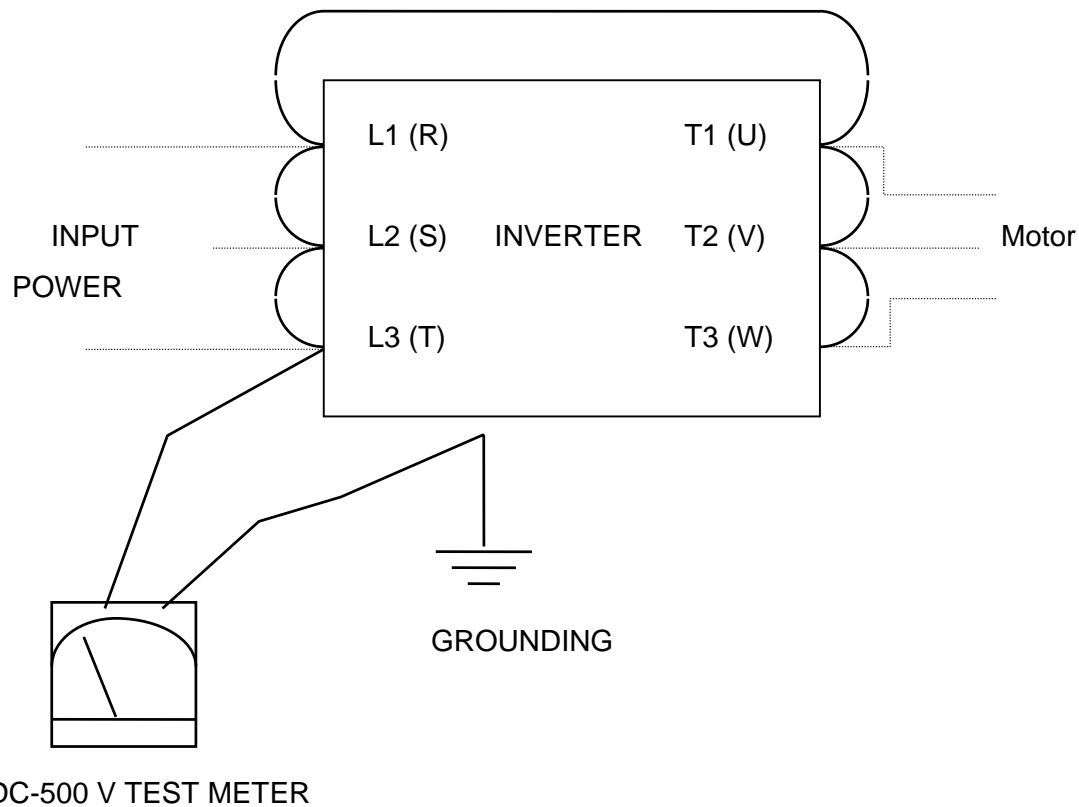

### **COMPATIBILITY (EMC) Filters:**

All modern PWM variable speed drives use fast switching power devices to achieve high efficiency and to reduce motor noise. This results in electromagnetic interference (EMI) and radio frequency interference (RFI). For operational reasons the interference may need to be suppressed.

### **EMC DIRECTIVES**

This Inverter is able to comply with the EMC Directives 89/336/EEC on limits to EMI and RFI with the use of an optional filter. Independent testing has demonstrated compliance to the following standards when the optional filters are used.

## EMI Emission

EN 50081-1 1992

EN 50081-2 1993

230 Volt Class .50HP - 3HP are compliant with class B filters

460 Volt Class 1HP - 5HP are compliant with class B filters

## EMS Immunity and LVD Safety Compliant

### FILTERING SELECTION

MODEL #	RATING	INVERTER MODEL
FM100-2EMI1	1 $\phi$ 220 - 250V/10A	FM100-2P5-N1, FM100-201-N1
FM100-2EMI2	1 $\phi$ 220 - 250V/20A	FM100-202-N1
FM100-2EMI3	1 $\phi$ 220 - 250V/20A	FM100-203-N1
FM100-4EMI1	3 $\phi$ 380 - 460V/10A	FM100-401-N1, FM100-402-N1
FM100-4EMI3	3 $\phi$ 380 - 460V/10A	FM100-403-N1, FM100-405-N1

### Interconnection Diagrams for 230 and 460 Filters

230 Volt Single Phase

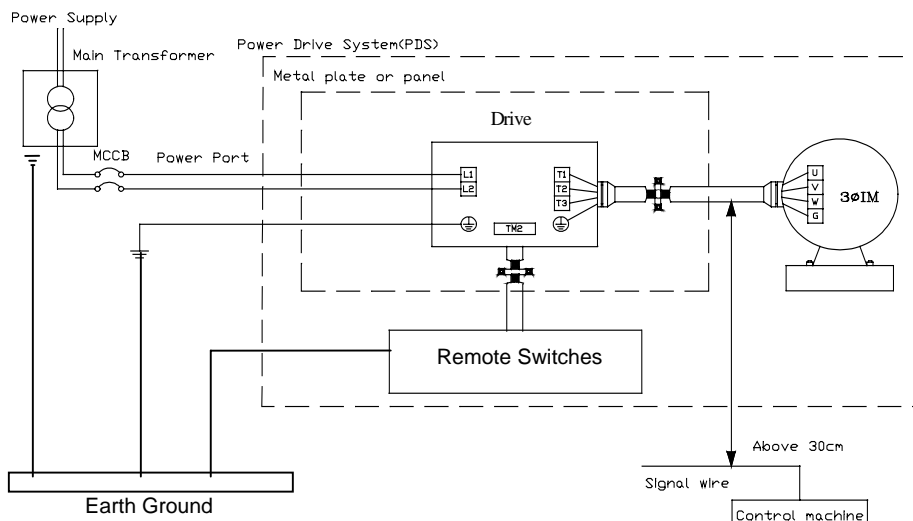

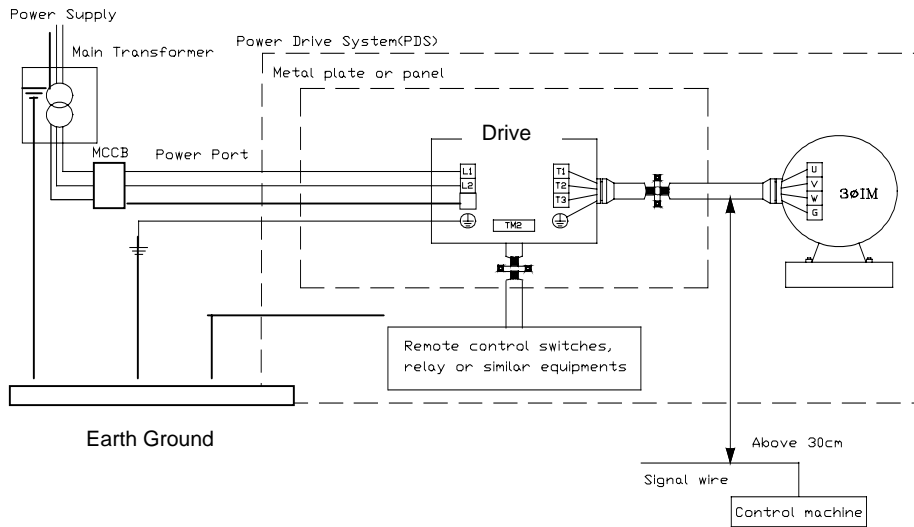

**ADDITIONAL PRECAUTIONS TO LIMIT EMI AND RFI**

Grounding Practices

**For Inverters:**

The Inverter must be grounded to earth independently. No other equipment should share the earth connection of the Inverter (except the motor). All circuits have to be connected to external earth through copper bars.

Note: The system should be checked periodically to ensure earth ground connection is complete.

**For Induction Motors:**

For safety reasons, motors must be connected to earth ground with a cable even if the motor is fixed on a metal baseplate. A green line 4-conductor motor cable is recommended to connect between the frame of the motor and the earth ground of the Inverter.

### **For Control Circuit:**

If the control circuit of Inverter is linked to any control switches, relays or other similar equipment, be sure the screened control line is put to earth ground on only one end.

### **For Shielding System:**

In order to have very low HF impedance, shielded cable with a metal clamp and special adapters are required. Remove paint on the surface of metal before grounding.

### **Shielding:**

The Inverter will emit EMI noise via the connection cable; therefore, all motor cables, control cables and signal cables must be shielded unless the length of the cable is less than 1 meter.

The shielded motor cable must be put to the earth ground. To reduce stray inductance and capacitance, the length of motor cable should be minimized.

### **Cable Routing**

All signal and control cable must be separated from unshielded or protected motor cable and unfiltered power lines. The distance should be more than 12in. (30cm). The control and power cables should be perpendicular to one another.

## **WARNING**

EMI filter can be used only in 3 phase supplies which are nominally balanced with respect to earth. Never apply EMI filter in a grounded delta supply system.

## Dimensions

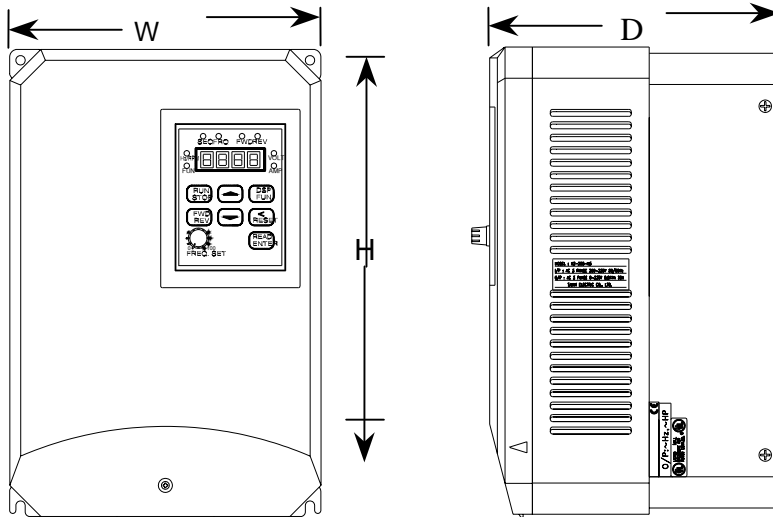

### 230 Volt Series    Units = Inches

Horsepower	.50	1	2	3	5	7.5	10	15	20	30
Dimensions (W) (H) (D)	4.22x6.38x 5.51		5.87x7.25x 6.22	7.28x8.46x 6.57	7.87x11.81x 7.83	9.84x15.75x9.45				
Mounting Dim. (W <sub>1</sub> ) (H <sub>1</sub> )	3.78x5.91		5.43x6.85	6.85x8.07	7.32x11.26	9.29x15.16				

### 460 Volt Series    Units = Inches

Horsepower	1	2	3	5	7.5	10	15	20	30
Dimensions (W) (H) (D)	5.87x7.25x6.22		7.28x8.46x 6.57	7.87x11.81x 7.83	9.84x15.75x9.45				
Mounting Dim. (W <sub>1</sub> ) (H <sub>1</sub> )	5.43x6.85		6.85x8.07	7.32x11.26	9.29x15.16				

## Braking Resistor and AC Reactors

MODEL	Built in Braking Transistor	Built in Braking Resistor	Braking Torque	Braking Resistor Code. No.	AC REACTOR	
					CURRENT (A)	Inductance(mH)
<b>230 Volt Units</b>						
FM100-2P5-N1	○	X	20%	FM100-2BR1	2.5	4.2
FM100-201-N1	○	X	20%	FM100-2BR1	5.0	2.1
FM100-202-N1	○	X	20%	FN100-2BR2	10.0	1.1
FM100-203-N1	○	X	20%	FM100-2BR3	15.0	0.71
FM100-205-N1	○	X	20%	FM100-2BR5	20.0	0.53
FM100-207-N1	○	X	20%	FM100-2BR7	30.0	0.35
FM100-210-N1	○	X	20%	FM100-2BR10	40.0	0.265
FM100-215-N1	X	X	20%	X	60.0	0.18
FM100-220-N1	X	X	20%	X	80.0	0.13
FM100-230-N1	X	X	20%	X	120.0	0.09
<b>460 Volt Units</b>						
FM100-401-N1	○	X	20%	FM100-4BR1	2.5	8.4
FM100-402-N1	○	X	20%	FM100-4BR2	5.0	4.2
FM100-403-N1	○	X	20%	FM100-4BR3	7.5	3.6
FM100-405-N1	○	X	20%	FM100-4BR5	10.0	2.2
FM100-407-N1	○	X	20%	FM100-4BR7	15.0	1.42
FM100-410-N1	○	X	20%	FM100-4BR10	20.0	1.06
FM100-415-N1	X	X	20%	X	30.0	0.7
FM100-420-N1	X	X	20%	X	40.0	0.53
FM100-430-N1	X	X	20%	X	60.0	0.36

○: as standard, X: as optional.