

SIMOREG DC Master

6RA70 Series

Microprocessor-Based Converters from 6kW to 2500kW
for Variable-Speed DC Drives

Application
SIMOREG for DC-Motor
Generator Set Control



NOTE

This application documentation does not purport to handle or take into account all of the equipment details or versions or to cover every conceivable operating situation or application. If you require more detailed information, or if special problems occur, which are not handled in enough detail in this document, please contact your local Siemens office.

The contents of this application documentation are not part of an earlier or existing agreement or legal contract and neither do they change it. The actual purchase contract represents the complete liability of the A&D Variable-Speed Drives Group of Siemens AG. The warranty conditions, specified in the contract between the two parties, is the only warranty which will be accepted by the A&D Variable-Speed Drives Group. The warranty conditions specified in the contract are neither expanded nor changed by the information provided in this application documentation.

**WARNING**

These converters contain hazardous electrical voltages and control rotating mechanical components (drives). Death, serious bodily injury or substantial damage to property will occur if the instructions in the relevant operating manuals are not observed.



Only qualified personnel who are thoroughly familiar with all safety notices contained in the operating instructions as well as erection, operating and maintenance instructions must be allowed to work on these devices.

Successful and safe operation of this equipment is dependent on careful transportation, proper storage and installation as well as correct operation and maintenance.

The reproduction, transmission or use of this document or contents is not permitted without express written authority. Offenders will be liable for damages. All rights, including rights created by patent grant or registration of a utility model or design, are reserved.

We have checked that the contents of this publication agree with the hardware and software described herein. Nonetheless, differences might exist and therefore we cannot guarantee that they are completely identical. The information given in this publication is reviewed at regular intervals and any corrections that might be necessary are made in the subsequent printings. Suggestions for improvement are welcome at all times..

SIMOREG ® is a registered trademark of Siemens

Contents

	Page
1 Introduction.....	4
2 Typical Connections	5
3 Selection of Components	6
4 Overview Block Diagram for Open and Closed Loop Control and Monitoring.....	8
5 Starting and Stopping Operation – Function of Control.....	10
6 Motor Field Converter Parameter Settings	12
7 Generator Field Converter Parameter Settings	13
8 Start-Up	20

1 Introduction

Until the early 1960's, DC motor variable speed control was obtained using an M-G set (Motor - Generator set). This involved a DC generator powered by a synchronous AC motor in combination with a DC motor. The generator armature voltage was controlled through the generator field circuit to provide a variable voltage source for the motor armature. In this sense, the generator acted as a high power variable voltage armature supply for the DC motor. The armature voltage of the generator was controlled using a low power generator field exciter and thus variable speed control of the motor was possible.

In the mid 1960's high power thyristor armature supplies became available and all new installations quickly changed to the new technology because it cost less, was more efficient, and required less maintenance.

Today there is still a relatively large installed base of large M-G set controlled motors that are in need of modernization. These are high horsepower applications mostly used in the metal industry. In some cases the system is upgraded by removing the generator and AC motor and replaced them with a thyristor armature supply which provides improved performance, efficiency, and maintainability.

In other situations, where the performance of the M-G set system is acceptable, and the condition of the M-G set is good, the cost of a complete upgrade to thyristor armature control can not be justified and the user may wish to simply upgrade the control system used with the M-G set for improved reliability and maintainability.

For these installations, a 4 quadrant 6RA70 SIMOREG can be configured using its standard features and freely programmable function blocks to perform a complete M-G set controller that provides the following main functions:

- Generator field current control
- Armature current control
- Motor speed control
- Motor field crossover control (with an additional motor field 6RA70)

The resulting control structure is a multi-loop system with 3 control loops. The inner most loop uses the normal armature current controller to control the generator field current. The second loop uses the normal technology controller to control the generator armature current and the third loop uses the normal speed controller to control motor speed. If field weakening is required an additional single quadrant 6RA70 must be used for the motor field exciter.

This application note describes the parameter settings necessary to implement a basic M-G set controller in the 6RA70 power module using the freely selectable function blocks. This description is intended to provide general guidelines to aid the user in implementing a typical M-G set control system and does not describe every possible implementation method. Depending on the application, some of the described features may not be required in which case the unused function blocks can be used to implement other application specific functions.

For the 6RA70 used for field control of generator following options are required:

CUD2 terminal expansion board: Option code K00

Technology Software (free function blocks): Option code S00

Limitations

1. Only the motor and generator field current loop and field characteristic curve can be self tuned.
2. Motor - Generator loop protection should be considered in the case of a 6RA70 fault. If a fault occurs in the generator controller the generator field current is brought to zero and if the motor is turning at the time it can circulate high armature current through the generator. This fault current can not be controlled by the 6RA70 and the generator since it is in a fault condition. Use of independent loop breakers or contactors can be used to protect the M-G set from excessive current. For that case of fault on SIMOREG for generator field under fault condition field reference for SIMOREG of motor field will be set to zero. That function is available with use of minimum software version of V2.13.
3. The 6RA70 has been designed as a motor armature controller but due to its flexible design it is able to be adapted to many other applications such as a M-G set controller. These special applications however require that the user be more knowledgeable in integrating the new

6RA70 into an existing custom system. A thorough understanding of the 6RA70 and its capabilities is recommended before attempting to apply it to complex custom systems.

The M-G set control described in this application note should only be implemented by skilled personnel knowledgeable in the areas of M-G set operation and the application of the 6RA70.

2 Typical Connections

SIMOREG 6RA70 for generator field

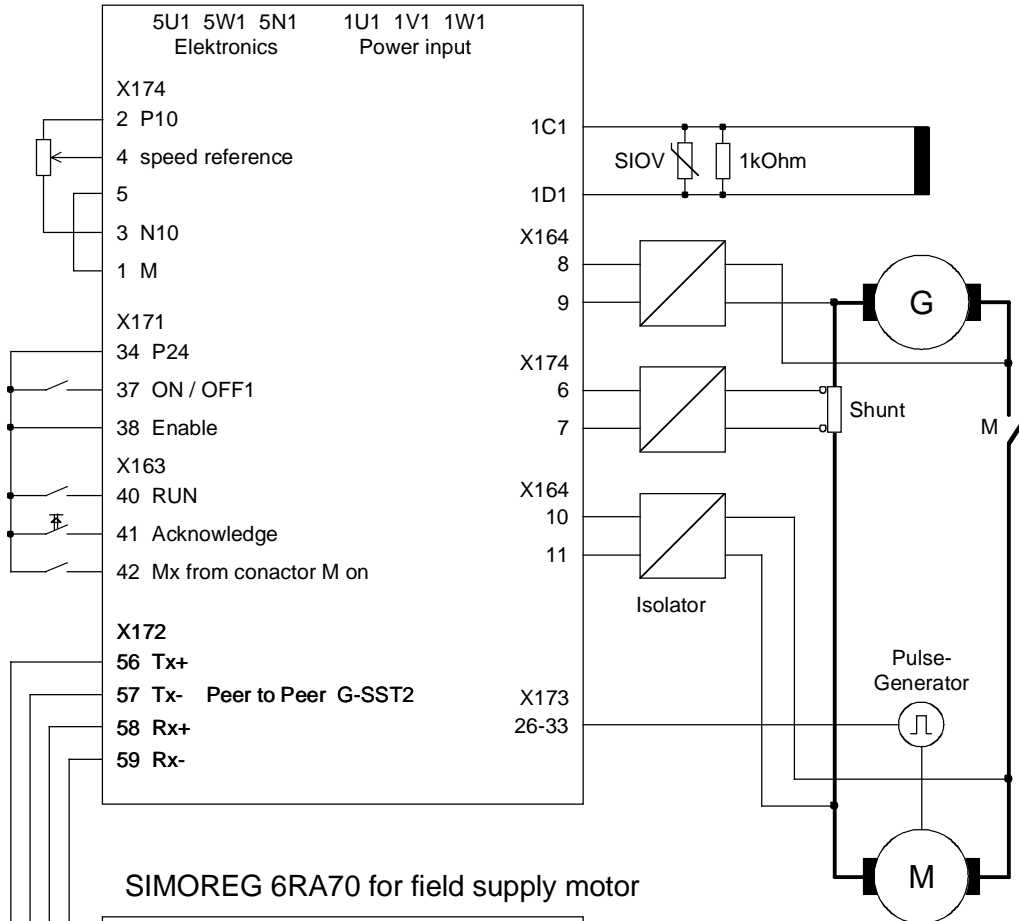

SIMOREG 6RA70 for field supply motor

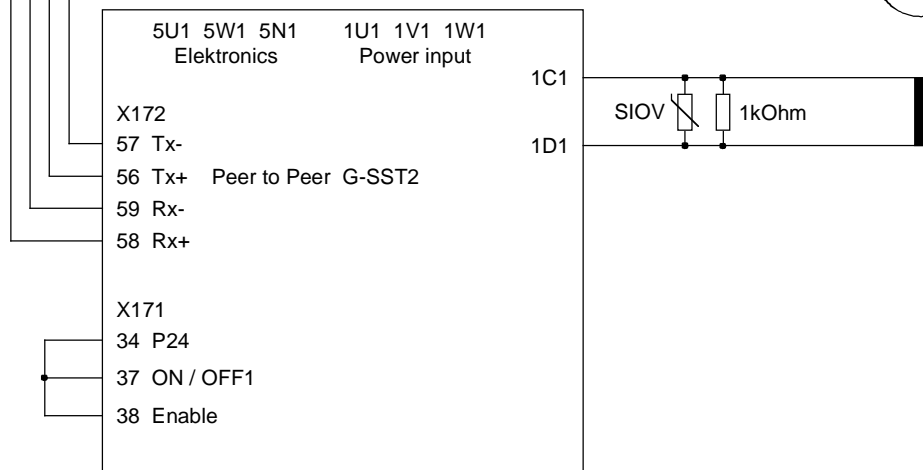

3 Selection of Components

3.1 SIMOREG for Generator Field Supply

The generator field 6RA70 converter should be selected as a 4 quadrant power module. The 4 quadrant design is necessary to allow the generator to produce both positive and negative output voltage to allow motor operation in either direction. Use of a power module is recommended since it is usually not desirable to have a contactor in a field circuit. Any of the normal armature converters can be used as a field supply without the need for modifications. The rated converter current should be selected to match the rated generator field current at maximum generator power.

For use SIMOREG as field supply long pulses for gating shall be selected, for safety firing of thyristors on high inductive load (Set parameter P079 = 1). For circulating free current on change over of torque direction on high inductive load, additional alpha W pulses are necessary (Set P179 = 3 to 7 depending on inductance of field coil). This allows the current on the active torque direction to zero before change direction of current.

Order SIMOREG with Option Z = K00 + S00

Minimum Software Version of SIMOREG shall be V2.13.

Order number for SIMOREG is SIMOREG: 6RA70..-6.V62-0-Z; Z = K00+S00

3.2 SIMOREG for Motor Field Supply

If a separate 6RA70 motor field converter is needed it should be selected as a single quadrant 3 phase power module. Since motor speed reversal takes place through armature control the field is not required to reverse. The rated converter current should be selected to match the rated motor field current.

Order number of SIMOREG: 6RA70..-6.S22-0

3.3 Isolators

Isolators are required to condition and isolate the current and voltage feedback from the M-G set. Since these isolators are in the main feedback circuits they must be responsive and should not be heavily filtered. The isolators must be able to provide output voltages of ± 10 VDC depending on the applied input quantity.

Armature Current Isolator

Armature current isolator should be high speed without filtering for high dynamic of current control. This isolator should be selected to operate with the current shunt located in the armature circuit of the M-G set. Although the isolator input will be less than 100 mv it must be insulated and rated for the total expected M-G set armature voltage from input to output and to ground. The scaling of the isolator should provide approximately ± 8 VDC at motor current limit. The output range from 8 VDC to 10 VDC is used for possible transient current overshoots.

Motor and Generator Isolators

These isolators must be rated for the expected M-G set armature voltage and provide approximately ± 8 VDC at rated motor or generator voltage. The output range from 8 VDC to 10 VDC is used for possible transient voltage overshoots.

3.4 Converter Output Pre-Load Resistors

When current of thyristors is lower as holding current, thyristors will get blocked. That under that condition overvoltage protection will not get active a preload resistor of ≤ 1 kOhms in parallel to field winding shall be used. The wattage of the resistors must be selected based on the rated generator or motor field voltage. ($P_v = U \cdot U/R$)

3.5 Converter Output SIOV Suppressor

An output SIOV suppressor is recommended to provide back-up over voltage protection in the event of a sudden power outage to help dissipate the energy stored in the field circuit. The energy is $L \cdot I^2 / 2$.

For 230/400 volt operation following suppressors are recommended:

Up to 400 Ws: Varistor SIOV-B32K460 (From Epcos company: www.epcos.com)

Up to 2000 Ws: Varistor SIOV-B80K460

> 2000 Ws: E89110-F2439-L1 (Overvoltage protection with thyristor from Siemens)

For 460/500 V operation following suppressors are recommended:

Up to 400 Ws: Varistor SIOV-B32K550

Up to 2000 Ws: Varistor SIOV-B80K550

> 2000 Ws: E89110-B2350-L1 (Overvoltage protection for 1Q with thyristor, from Siemens, for 4Q use two of them connected antiparallel)

3.6 Input Line Fuses and Commutating Reactors

Input line fuses should be selected based on the converter rating. Fuse selection information is located in the 6RA70 instruction manual. Use Commutating Reactor regarding catalog DA21.1 or isolating transformer for line voltage.

4 Overview Block Diagram for Open and Closed Loop Control and Monitoring

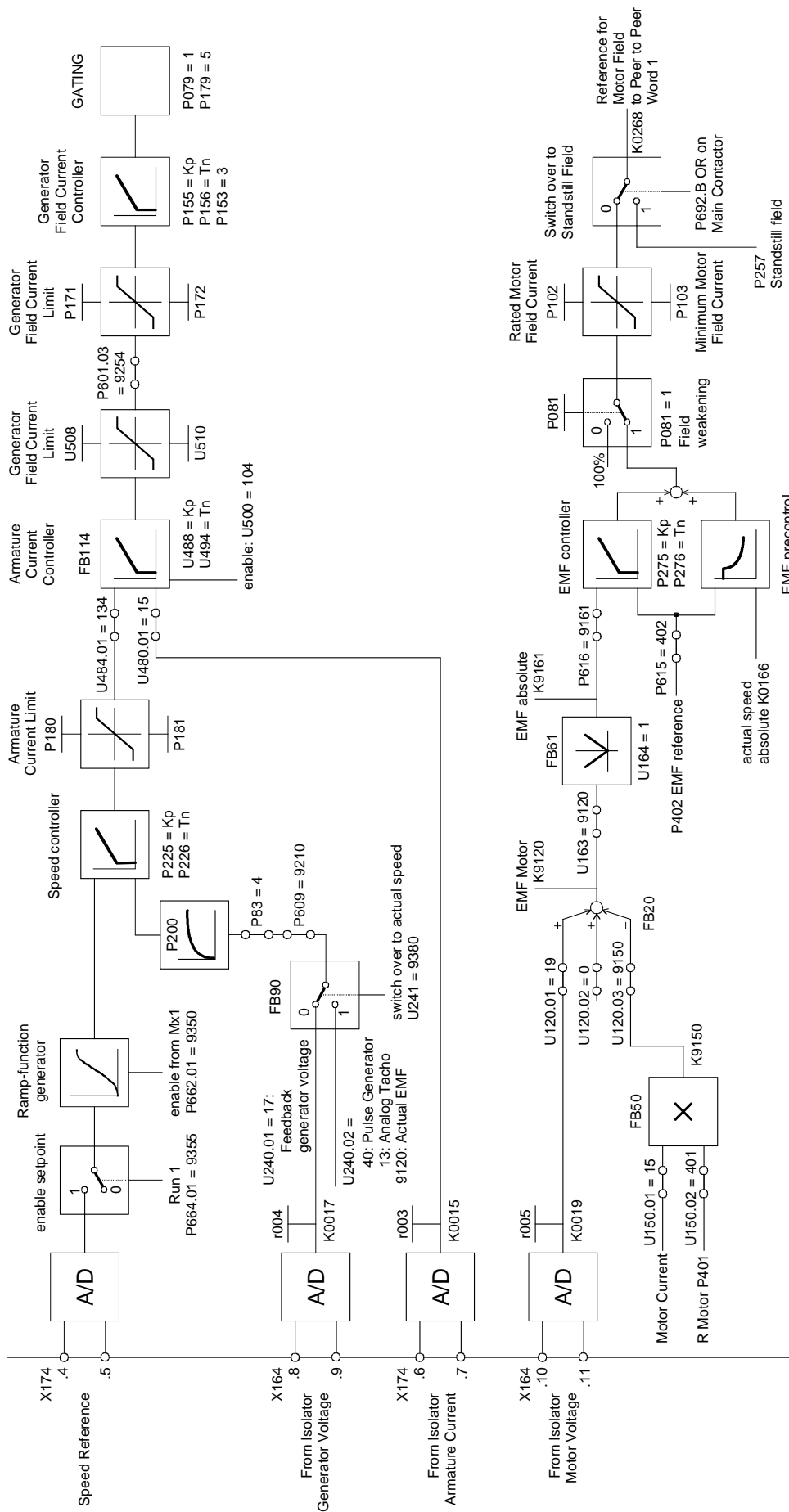

Zero Speed Detector

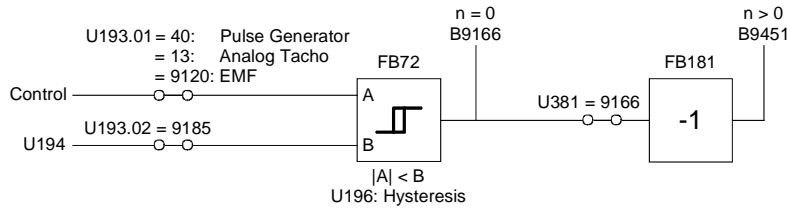

Armature Over Current Fault Detector

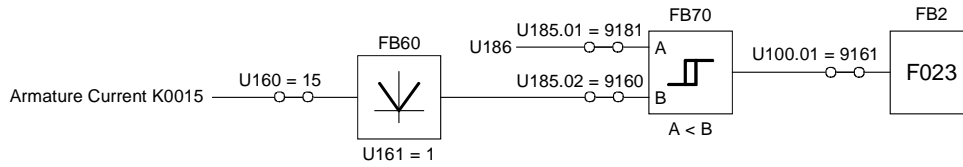

Tacho Loss Fault Detector

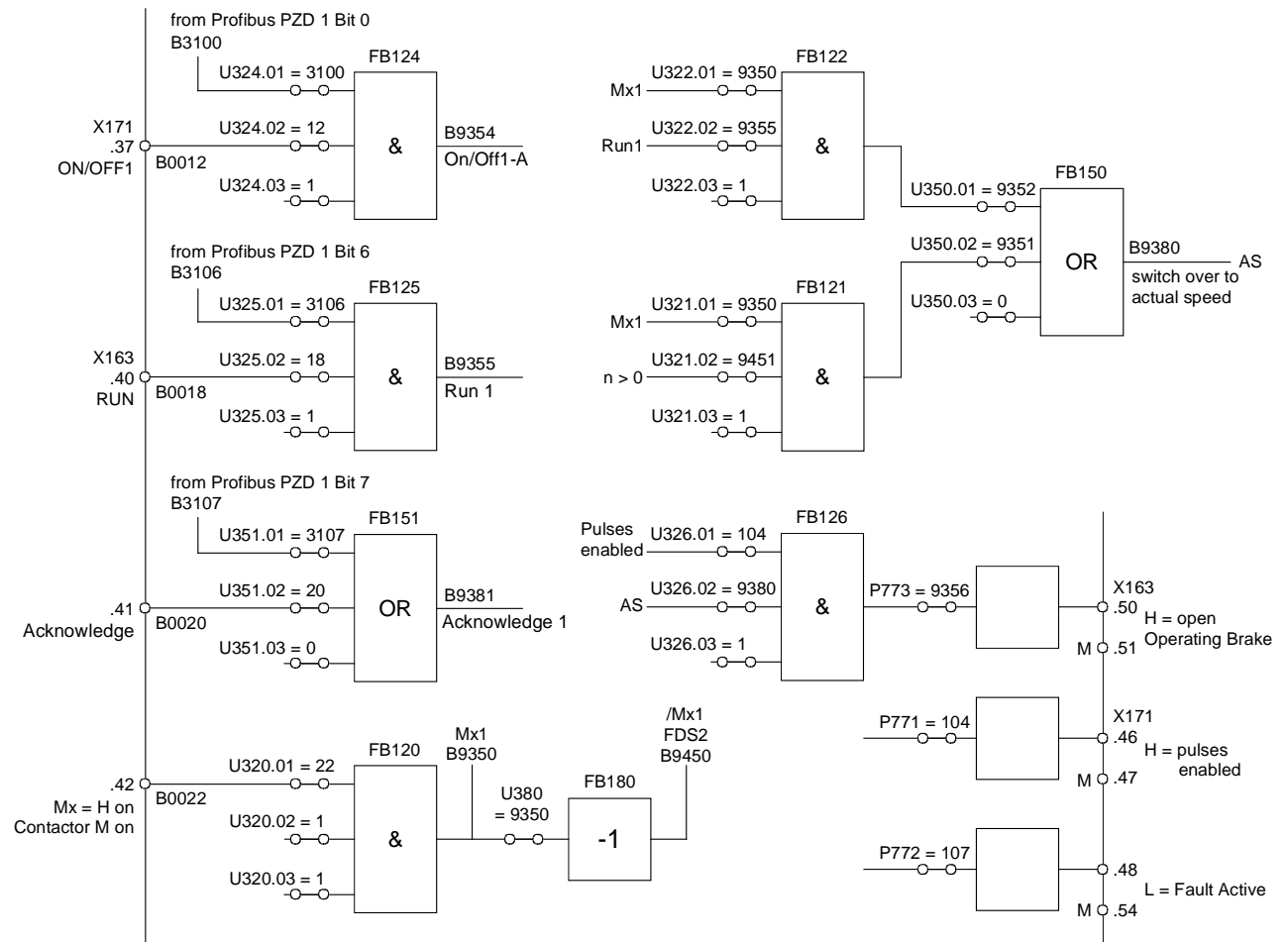
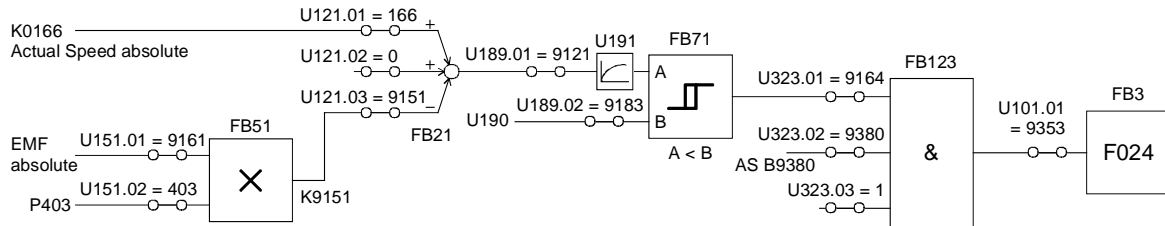

5 Starting and Stopping Operation – Function of Control

5.1 Recommended Starting Sequence

	Action	Comments
1	Close „On/Off1“ contact	The field converter for motor and generator switch on. That enable controller and regulate for zero generator voltage. The actual value for the speed controller is the generator voltage and the main reference for speed is zero
2	Close the armature loop circuit, Contacter „M“	This closes the armature loop while the generator voltage is regulated for zero so current will not flow.
3	Close the „Run“ contact	This will release the speed reference in front of the ramp generator and select speed feedback. The motor should begin to accelerate up to speed following the selected ramp rate.
4	Vary the speed reference to get the desired operating speed	Motor speed will follow the changes in the speed reference

5.2 Recommended Stopping Sequence

	Action	Comments
1	Either bring the external speed reference to zero or open the “Run” contact.	When the “Run” contact is opened the speed reference before the ramp generator will be set to zero and the motor will decelerate to zero speed following the internal ramp rate. When zero speed is reached zero voltage regulation will be selected.
2	At any time, if the main loop contactor opens the generator control will be switched to a zero voltage regulator. This is necessary for generator protection.	Voltage feedback will be selected when the speed is less than minimum or when the “Mx” contact is opened indicating that the main armature loop is open. The system will now regulate for zero generator voltage.
3	Open the “On/Off1” contact	This will turn the controllers off and block gate pulses.
4	Open the armature main contactor “M”	This opens the armature circuit and prevents current flow due to generator residual voltage.

5.3 Functions of Control and Monitoring

	Function	Comments
1	„On/Off1“	Can be given by terminal 37 and Profibus When Profibus used: terminal 37 & Bit from Profibus Will also be given via Peer to Peer to SIMOREG for motor field. “On” enables controllers, a separate signal for enable shall not be used for that application. Set terminal 38 permanent to High. „Off1“ disable controllers, make current to zero and block gating pulse
2	„Off2“	„Off1“ on that application has same effect as „Off2“ Do not use „Off2“
3	„Off3“	„Off3“ fast stop can not be used for that application Remedy: Switch off “Run” command and switch over ramp function generator to fast ramp-down time for fast stop
4	„Run“	„Run“ can come from terminal 40 or Profibus Enable speed reference on input of ramp function generator
5	„Acknowledge“	Can come from terminal 41 or Profibus Will also be given via Peer to Peer to SIMOREG for motor field. After Acknowledge fault set “On/Off1” to Low to get status: “Ready to switch on”.
6	„Mx“	Signal back from armature contactor „M“ to terminal 42 “Mx” = High-signal, contactor “M” is switched on <u>Mx = Low</u> : Switch over to generator voltage regulation Disable ramp function generator (set output to zero) for reference zero for voltage control, select FDS 2 for armature current controller of generator
7	„Switch over to actual speed“	Switch over when: “Mx” = High and “Run” = High Or when “Mx” = High and “n > 0”, (Signal “AS”) When “Switch over to actual speed” tacho loss monitoring will get active
8	„n = 0“	The monitoring „n < nmin“ of SIMOREG can not be used because of need of special „Off1“ function. Set parameter for n < nmin limit to high value. For “n = 0” a extra limit value monitor will be used.
9	Fault indication	On fault indication of SIMOREG for generator field, field current will be set to zero (no field current control possible), in that case high armature current can happen. Therefore on that condition also field current reference for motor will become zero.
10	„Pulses enabled“	On message „Pulses enabled“ binary output terminal 46 = High
11	„Fault“	On message „Fault“ binary output terminal 48 = Low On fault indication of SIMOREG of motor field, actual current signal over Peer to Peer back to generator control will become zero and F005 will happen on SIMOREG for generator.
12	Brake control	The brake control implemented in SIMOREG can not be used for that application. For control of a operating brake following can be used: Close brake when: pulses blocked, contactor „M“ open, „Run“ is Low and “n = 0”. Open brake with binary output terminal 50 = High
13	Profibus	The 1 st Process Data Word from Profibus must be Control word 1 and Bit 10 of it must be set to High, for getting Process Data active. For control not complete Control word 1 is used, only the relevant Bits for that application are selected Bit by Bit. Speed reference can come from Process Data Word 2. The parameter example is for use of terminals or Profibus for control.

6 Motor Field Converter Parameter Settings

Unless the drive has been pre-set at the factory, the first step in adjusting the SIMOREG motor field converter is to perform the factory default procedure. This configures the converter for the correct voltage and current rating and assures that all other parameters are at the factory default values.

Setting parameters to default values: P051 = 21.

After "Setting of General Parameters" do optimization of current controller. That can be done by self tuning with parameter P051 = 25. For optimization use terminal 37 for "On/Off1".

After that do setting of the additional parameters.

Setting of General Parameters

Parameter	Comments
P051 = 40	Key parameter for access to parameter values
P076.01 =	Reduction of converter rated DC current
P078.01 =	Rated input voltage armature (voltage for 1U1/1V1/1W1)
P079 = 1	Select Long pulses for gating
P082 = 0	Internal field is not used
P083 = 4	Actual speed value is wired up freely
P086 = 0	No automatic restart
P100 =	Rated current of motor field
P110 =	Resistance of motor field, will be set by self tuning of current controller
P111 =	Inductance of motor field, will be set by self tuning of current controller
P153 = 3	Armature precontrol for large inductance load
P155 =	Kp current controller, will be set by self tuning of current controller
P156 =	Tn current controller, will be set by self tuning of current controller
P179 =	Additional alpha W pulses: set 3 to 7 depending of inductance of motor field
P609 = 0	Source for actual speed
P820.07 = 42	Disable tachometer fault indication

Setting of additional parameters

Parameter	Comments
P084 = 2	Operation under closed loop current control
P601.03 = 6001	Current reference from word 1 over Peer To Peer
P790 = 5	Select Peer to Peer over G-SST2
P791 = 2	Set number of process data is two for Peer to Peer
P793 = 13	Baud rate is 187.5 kBd for Peer to Peer
P794.01 = 116	Absolute value of actual current as first word to Peer to Peer
P794.02 = 32	Status word 1 as second word to Peer to Peer
P795.01 = 1	Bus terminator on
P797 = 0.3	Telegram failure time for Peer to Peer is 0.3 s
P654.01 =	P654.01 = 6200: "On/Off1-A" from Peer to Peer word 2 Bit 0 for "On/Off1" Receive data word 2 Bit 0 & terminal 37: for "On/Off1" P654.01 = 1: „On/Off1“ only by terminal 37
P665.01 = 6201	Fault Acknowledge: from Peer to Peer word 2 Bit 1 (from Acknowledge1 Generator)
P666.01 = 10	Fault Acknowledge from terminal 36 Only necessary when no Acknowledge over Peer to Peer

7 Generator Field Converter Parameter Settings

Unless the drive has been pre-set at the factory, the first step in adjusting the SIMOREG generator field converter is to perform the factory default procedure. This configures the converter for the correct voltage and current rating and assures that all other parameters are at the factory default values. Reset to default values: set P051 = 21.

After setting of "General Setup Parameters" and parameters for "Generator Field Current Controller" first optimize current controller for field current of generator. That can be done by using the self tuning with P051 = 25. After that do setting of all further parameters.

Set all parameters of function data set 1 (FDS 1) and after that optimize further controllers. Then copy FDS 1 to FDS 2 (P055 = 112: copy FDS 1 to FDS 2). When copy is finished set specific parameters for FDS 2

General Setup Parameters

Parameter	Comments
P051 = 40	Key parameter for access to parameter values
P076.01 =	Reduction of converter rated DC current
P078.01 =	Rated input voltage armature (voltage for 1U1/1V1/1W1)
P079 = 1	Select Long pulses for gating
P086 = 0	No automatic restart
P082 = 21	Use extern SIMOREG for field supply of motor, Field reference enable on „On/Off1-A“ = High
P097 = 0	Under fault condition: set reference for field current of motor to zero Available from software version 2.13
P100 =	Rated field current generator
P102 =	Rated field current motor
U838 =	Set to value of parameter r072.02 from SIMOREG of motor field
P179 =	Additional alpha W pulses :P179 = 3 to 7 depend on inductance of generator field

Generator Field Current Controller

Parameter	Comments
P110 =	Resistance for generator field, will be set by self tuning of current controller
P111 =	Inductance for generator field, will be set by self tuning of current controller
P155 =	Kp current controller, will be set by self tuning of current controller
P156 =	Tn current controller, will be set by self tuning of current controller
P153 = 3	Armature precontrol for large inductance load
P601.03 = 9254	Output of technology controller for reference of current controller of generator field (Armature current controller SIMOREG). That shall be set AFTER the optimization of the current controller SIMOREG with P051 = 25

Armature Current Controller with Technology Controller FB114

Parameter	Comments
U488.01 = 0.1	Kp armature current controller, shall be tuned manually
U494.01 = 0.5	Tn armature current controller, shall be tuned manually
U508 =	Positive generator field current limit. Scaling 100% = r072.02 current, U508.F = P100 / r072.02 * 100%
U510 =	Negative generator field current limit. Scaling 100% = r072.02 Strom U510.F = P100 / r072.02 * 100% (set positive value)
U480.01 = 15	Select K0015 actual armature current generator from terminal 6/7 as input for FB114
U484.01 = 134	Output speed controller as reference for armature current controller
U500 = 104	Enable technology controller when pulses enabled

Armature Current Controller Function Dataset 2

Parameter	Comments
U488.02 = 1	Kp armature current controller FDS 2, used on voltage control of generator when contactor „M“ open
U504.02 = 0	Set I component to zero, used on voltage control of generator when contactor „M“ open

Speed Reference and Ramp Function Generator

Parameter	Comments
P433 =	P433 = 11 Speed reference from terminal 4&5 (factory setting) P433 = 3002 Speed reference from Process Data Word 2 from Profibus, Scaling 14 Bit (4000Hex) for +100%. Bit No. 15 (MSB) = High for negative reference (C000Hex = -100%)
P639.01 = 0	Set ramp function generator output to zero at moment of switch on
P662.01 = 9350	„Mx1“ = High of B9350: enable ramp function generator
P664.01 = 9355	Enable speed reference on input of ramp function generator when „Run1“ = High
P303 = 20	Ramp-up time 1, depend on application
P304 = 10	Ramp-down time 1 depend on application
P305 = 2	Lower transition rounding 1, depend on application
P306 = 2	Upper transition rounding 1, depend on application

Motor Speed Controller

Parameter	Comments
P083 = 4	Actual speed value is wired up freely (selected in P609)
P169 = 0	P180 / P181 as current limit for armature current limit of generator
P180 =	Positive armature current limit, 100 % is scaling of 100 % from shunt
P181 =	Negative armature current limit, 100% is scaling of 100 % from shunt
P200 = 20	Filter time for speed feedback is 20 ms. Depend on application.
P225 = 10	Kp for speed controller, shall be tuned manually
P226 = 0.5	Tn speed controller, shall be tuned manually
P609 = 9210	Select actual speed from FB90: Connector change over switch
U240.01 = 17	Actual armature voltage of generator from terminal 8&9 to input 0 of FB90 Adjusted by Isolator on terminal 8&9 and P721
U240.02 =	Select actual speed for input 1 of FB90 U240.02 = 40: Actual speed from impulse generator K0040, set P140 - P148 U240.02 = 13: Actual speed from analog tacho terminal 103&104, Normalization with P741 U240.02 = 9120 No tacho used. For control motor armature voltage from terminal 10&11 minus I * R drop is used for actual speed (actual EMF, K9120). EMF control has higher accuracy as only voltage control because I * R drop will be compensated.

EMF Calculation

Parameter	Comments
U120.01 = 19	Armature voltage motor from terminal 10&11 to +input 1 of adder FB20
U120.02 = 0	Signal zero on +input 2 of FB20
U120.03 = 9150	I*R drop calculated by multiplier FB50 on -input 3 of FB20
U150.01 = 15	Armature current generator from terminal 6&7 on 1. input of FB50
U150.02 = 401	Fixed value K0401. Setting by P401 for R part to input 2 of FB50
P401 = 4	Typical value 4%. Value of armature resistance factor. This equals the % of I*R drop. Depend on motor armature resistance.
U163 = 9120	Output K9120 of FB20 is EMF bipolar, will be set as input of absolute value generator FB61
U164 = 1	Positive absolute value for output of FB61 selected. K9161 is EMF

Motor Field Weakening Controller

Parameter	Comments
P081 =	P081 = 0 No field weakening operation, Parameters for field weakening controller and field characteristic not used. P081 = 1 Field weakening by internal closed-loop EMF control used. Set after self tuning of field characteristic with P051 = 27.
P275 = 0.6	Kp EMF controller, set by self tuning with P051 = 27
P276 = 0.2	Tn EMF controller, set by self tuning with P051 = 27
P616 = 9161	EMF K9161 from FB61, as actual EMF for EMF controller
P615 = 402	Fixed value K0402, setting by P402 as reference for EMF controller
P402 = 96	EMF reference, set to rated motor voltage minus I*R, typical 96 %, depend on armature resistance of motor.

Field Characteristic

Parameter	Comments
P117 =	Control word for field characteristic. 1 for valid field characteristic, Will be set automatically after P051 = 27
P118 =	Motor rated EMF, will be set by P051 = 27 The value for that application is not correct, because it depend on parameter P078.
P119 =	Motor base speed in % of maximum speed, will be set by P051 = 27
P120 bis P139	Points for field characteristics, will be set by P051 = 27

Generator Armature Over Current Fault Detector, Fault Indication F023

Parameter	Comments
U160 = 15	Actual armature current K0015 to absolute value generator FB60
U161 = 1	Select positive absolute value
U185.01 = 9181	Limit for over current detector to input A of Limiter FB70
U185.02 = 9160	Actual armature current , output of FB60 to input B of FB70
U186 = 115	Limit for overcurrent detection, set to appr. 115%, With given scaling max. 125% possible.
U100.01 = 9161	Output of FB70 connected to input FB2 free fault indication, On overcurrent F023 happen.

Tacho Loss Fault Detector, Fault Indication F024

Parameter	Comments
U121.01 = 166	Absolute value of actual speed to +input 1 of adder FB21
U121.02 = 0	+input 2 of FB21 not used
U121.03 = 9151	Output of multiplier FB51 to -input3 of FB21
U151.01 = 9161	EMK to input 1 of FB51
U151.02 = 403	K0403, (setting of value by P403) to input 2 of FB51
P403 =	This is equal to: $1 / \text{field speed range} * 100\%$ On no field weakening used set to 100% For example on field speed range is 3 : 1 it is: $1 / 3 * 100 = 33\%$ for P403
U189.01 = 9121	Output of FB21 to input A of limiter FB71. For normal operation this signal is zero or positive. A negative signal less than U190 is a tach fault. On fault utput $A < B$ of FB71 = High.
U189.02 = 9183	Fixed value K9183 (setting by U190) to input B of FB71
U190 = -5	Select -5% as the threshold for tachometer loss. For example -10% is less sensitive as -5%
U191 = 10	Filtering 10 ms for detector input.
U323.01 = 9164	Output of FB71 to AND-element FB123 input 1
U323.02 = 9380	Signal „AS“: B9380 to FB123 input 2, Activate monitoring of tacho loss when tacho for actual speed is selected
U323.03 = 1	High-Signal to FB123 input 3
U101.01 = 9353	Output of FB123: B9353 = High indicate tacho loss F024 with FB3

Fault Suppression

Parameter	Comments
P820.07 = 42	Suppress the internal tacho loss function. The internal tacho loss function will not work correctly for that application because output of SIMOREG is used for supply of the field winding.
U100.01 = 0	Suppress F023 armature over current of generator
U101.01 = 0	Suppress F024 tacho loss

Zero Speed Detector

Parameter	Comments
U193.01 =	Actual speed to input A of limiter FB72 U193.01 = 40 for use of impulse generator U193.01 = 13 for use of analog tacho U193.01 = 9120 for EMF control, operation without tacho (only guilty when field current for motor is active)
U193.02 = 9185	K9185 (Setting with U194) as limit to input B of FB72
U194 =	Limit for "n = 0" detection, set to appr. 0,5 – 3 % Set to higher value for operation without tacho.
U196 = 0.5	Hysteresis for zero speed detector appr. set to 0,5%
U381 = 9166	Output of FB72: $ A < B$: B9166 (High on "n = 0") to inverter FB181 B9451 output of FB181 (High on "n > 0")

Analog Input Scaling

Parameter	Comments
P711 = 125%	Scaling for analog select input 1 for +100 % at r003 when +8 V is applied to terminal 6&7
P717 = 14	High resolution 14 Bit and 3,5 ms measurement time, for smooth control
P721 = 125%	Scaling for analog select input 2 for +100% at r004 when +8 V is applied to terminal 8&9
P731 = 125%	Scaling for analog select input 3 for +100% at r005 when +8 V is applied to terminal 10&11

Control: On/Off1

Parameter	Comments
U324.01 =	U324.01 = 3100: „On/Off1“ from Profibus Controlword 1 Bit 0 to input 1 of AND-element FB124 „On/Off1“ from Profibus & terminal 37 U324.01 = 1: „On/Off1“ only from terminal 37
U324.02 = 12	On-signal from terminal 37 to input 2 of FB124
U324.03 = 1	Set input 3 of FB124 to High signal
P654.01 = 9354	“ON” with output FB124: B9354 = High (On/Off1-A)
P370 = 199.99	Set n < nmin limit to large value, necessary for correct reaction of „Off1“ on that application

Control: „Run“ (Speed Reference Enable)

Parameter	Comments
U325.01 / .02 =	U325.01 = 3106 and U325.02 = 18: „Run“ from Profibus Controlword 1 Bit 6 & terminal 40 U325.01 = 1 and U325.02 = 18: „Run“ only from terminal 40 U325.01 = 3106 and U325.02 = 1: „Run“ only from Profibus
U325.03 = 1	High-signal to input 3 of FB125

Control: Fault Acknowledge

Parameter	Comments
U351.01 = 3107	Select Controlword 1 Bit7 of Profibus as input 1 of OR-element FB151
U351.02 = 20	Select terminal 41 as input 2 of FB151
U351.03 = 0	Low-signal to input 3 of FB151
P665.01 = 9381	Output of FB151: B9381 (Acknowledge 1) to SIMOREG Controlword 1 Bit 7 Acknowledge from Profibus OR terminal 41

Control: Switch Over to Actual Speed and FDS 2

Parameter	Comments
U320.01 = 22	Signal „Mx“ from terminal 42 to input 1 of AND-element FB120
U320.02 = 1	High-Signal to input 2 of FB120
U320.03 = 1	High-Signal to input 3 of FB120
U380 = 9350	Output of FB120: B9350 to input INVERTER-element FB180
P676.01 = 9450	Output of FB180: “/Mx1”, B9450 to SIMOREG Controlword 2 Bit 16 “/Mx1” = High select FDS 2
U321.01 = 9350	Output of FB120 „Mx1“ to input 1 of AND-element FB121
U321.02 = 9451	Output of FB181 “n > 0“ to input 2 of FB121
U321.03 = 1	High-signal to input 3 of FB121
U322.01 = 9350	Output of FB120 „Mx1“ to input 1 of AND-element FB122
U322.01 = 9355	Output of FB125 „Run1“ to input 2 of FB122
U322.03 = 1	High-signal to input 3 of FB122
U350.01 = 9352	Output of FB122 to input 1 of OR-element FB150
U350.02 = 9351	Output of FB121 to input 2 of FB150
U350.03 = 0	Low-signal to input 3 of FB150
U241 = 9380	„AS“ output from FB150: B9380 = High for switch over to actual speed with Connector changeover switch FB90

efesotomasyon.com

Parameter for Peer to Peer Over G-SST2

Parameter	Comments
P790 = 5	Select Peer to Peer for G-SST2
P791 = 2	Use of two words for Peer to Peer
P793 = 13	Baud rate 187,5 kBd
P795.01 = 1	Bus terminator ON
P797 = 0.3	Telegram failure time 0,3 s for Peer to Peer
P794.01 = 268	Select reference for motor field current as first word for transmit data over Peer to Peer
P612.01 = 6001	Select actual motor field current from receive data word 1 over Peer to Peer. Used for tuning of motor field characteristic and monitoring of motor field current. When fault on SIMOREG for motor occur, F005 on SIMOREG for generator will be indicated.
U117.01 = 9354	„On/Off1-A“: B9354 to binector/connector converter Bit 0
U117.02 = 9381	„Acknowledge1“: B9381 to binector/connector converter Bit 1
P794.02 = 6020	K6020 from binector/connector converter as second transmit data word over Peer to Peer

Parameter for Binary Outputs

Parameter	Comments
P771 = 104	Indication „Pulses enabled“ with binary output: terminal 46 = High
P772 = 107	Indication „Fault“ with binary output terminal 48 Terminal 48 = Low for “Fault active”
U326.01 = 104	Signal „Pulses enabled“ to input 1 of AND-element FB126
U326.02 = 9380	Signal „AS“ to input 2 of FB126
U326.03 = 1	High-signal to input 3 of FB126
P773 = 9356	Output of FB126 selected for binary output terminal 50 Terminal 50 = High for: “Open operating brake”

Parameter for Free Function Modules in Software FBxxx

Parameter	Comments
U950 – U952	Select time slice 1 for sampling time is $1 \cdot T_0$ for all used free function modules Following free function modules are used: FB2, FB3, FB20, FB21, FB50, FB51, FB60, FB61, FB70, FB71, FB72, FB90, FB114, FB120, FB121, FB122, FB123, FB124, FB125, FB126, FB150, FB151, FB180, FB181
U969 = 2	Set optimum sequence of function modules
U969 = 4	Automatic activation / deactivation

Parameter for Profibus

Parameter	Comments
P918 =	Select Profibus address
P927 = 7	Parameter changes possible from PMU or G-SST1 or Profibus
U722.01 = 500	Telegram failure time is set to 500 ms. Fault message F082 is displayed if no process data exchanged. When U722.01 = 0 no fault message on bus failure, old values for process data are frozen and drive can only be switched off by terminal 37. We recommend to set a telegram failure time > 0
U734.01 = 32	Transmit data word 1 to Profibus is status word 1 from SIMOREG of generator1.
U734.02 = 167	Transmit data word 2 to Profibus is actual speed.
U734.03 = 6002	Transmit data word 3 to Profibus is status word 1 of SIMOREG for Motor field. From Peer to Peer receive data word 2

Display Parameter

Parameter	Comments
r003	Armature current of generator
r004	Armature voltage generator
r005	Armature voltage of motor
r029	Speed reference before reference enable
r028	Speed reference on input of ramp function generator
r027	Speed reference on input speed controller
r025	Actual speed before filtering with P200
r021	Reference for armature current controller after limit P180
n017	Reference for armature current controller FB114
n016	Actual value for armature current controller FB114
n019	Field current reference generator after limit U508
r020	Field current reference after limit P171
r018	Firing angle armature current SIMOREG
r019	Actual armature current SIMOREG (actual field current generator)
r036	Field current reference for motor field

8 Start-Up

8.1 Check Old System

Run old system – note polarities and levels:

- a) Polarity and rated current of field for generator and motor
- b) Armature voltage
- c) Armature current
- d) Speed feedback
- e) Speed reference

8.2 Connections

Shut Down Generator-Prime Mover

Disconnect wiring from existing and wire to new Siemens controller regarding chapter 2 "Typical Connections"

8.3 Isolator Calibration

The isolators need to be calibrated and have the polarity verified before they can be used. Calibrate and verify isolator output polarity using appropriate test voltages to simulate actual feedback signals

Armature Current Isolator

Disconnect one of the shunt cable leads at the isolator and apply a mv test signal, equal to the shunt mv at maximum armature current (current limit), between the isolator terminal and the disconnected lead. This technique will compensate for any IxR drop in the cable between the shunt and the isolator. The polarity of the test signal needs to agree with the polarity from the shunt when forward armature current is flowing. The output of the isolator must be positive for forward current.

Adjust the isolator to get an output equal to 8 VDC when the mv test signal is set to the required current limit value. Terminal 6 must be positive with respect to terminal 7 for this condition.

Verify parameter r003 = +100% at this time. If necessary, adjust parameter P711 to get exactly +100% at parameter r003.

Reverse the polarity of the test signal and verify r003 becomes -100%

Remove the test voltage and reconnect the isolator circuit.

Generator Voltage Isolator

Disconnect the input voltage cable leads from the isolator and apply a test voltage equal to the rated generator armature voltage. The polarity of the test voltage must agree with the polarity of the generator voltage when forward generator voltage is present. Adjust the isolator to get +8 VDC output.

Verify parameter r004 = +100% at this time. If necessary, adjust parameter P721 to get exactly +100% at parameter r003.

Reverse the polarity of the test signal and verify r004 becomes -100%

Remove the test voltage and reconnect the isolator circuit.

Motor Voltage Isolator

Disconnect the input voltage cable leads from the isolator and apply a test voltage equal to the rated motor armature voltage. The polarity of the test voltage must agree with the polarity of the motor voltage when forward voltage is present. Adjust the isolator to get +8 VDC output.

Verify parameter r005 = +100% at this time. If necessary, adjust parameter P731 to get exactly +100% at parameter r005.

Reverse the polarity of the test signal and verify r005 becomes -100%.

Remove the test voltage and reconnect the isolator circuit.

8.4 Set Parameters

Determine the exact configuration of the drive and enter the required parameters. First set only the "General parameter" and "Parameter for generator field", then do the optimization of the current controller of generator and motor field. After that set all other required parameters, then the drive is ready to be commissioned.

The following guidelines will help get the unit started in an orderly fashion.

8.5 Optimization Field Current Controller Motor and Generator

For that Generator is Shut Down and "M" contactor shall be open.

Self Tuning

The field current controller must be tuned for optimum performance. This can be accomplished without running the motor or generator and by using the self tuning procedure available for this controller, (P051 = 25). When self tuning the current controller, fault indication F050 can happen. In that case acknowledge fault and read out diagnostics parameter r047.01. If it show value = 29 or 30 or 31, no further action necessary, the current controller is tuned correctly for medium dynamic. After the self tuning the response of the motor or generator field current loop should be verified and if possible improved with manual tuning. Since this is a 3 loop system it is important to make the inner most loop as responsive as possible to assure good performance of the outer speed loop.

Manual Tuning

Temporarily set parameter P601.01 to set a base generator field current level of 25% of rated generator field current and inject additional 2% current steps. Adjust the current controller gain, P155, and time constant, P156, to achieve a current rise time, 0 to 63% of final value, of approximately 20 ms. Typical values are P155 = 10, P156 = 0.1 seconds.

Following test signal can be used: Set P601.03 = 208 oscillating circuit output (see chapter 8 sheet G128 of SIMOREG manual) for test reference. 100% is rated converter current r072.02. Measure the current response on terminal 12&13.

After tuning set back P601.03 to correct value for control. For the generator field current controller, when tuning is complete, verify proper field current reversal takes place by reversing the reference several times. Adjust P179 to a safe value that there is no circulating current occurs.

Verify polarity of signal for forward operation/motoring armature current.
Stop Siemens Drive and prepare to step armature current loop.

8.6 Optimization Armature Current Controller

The armature current controller must be manually tuned. This can be accomplished using the test reference described for the generator field current controller. To perform the armature current controller tuning the M-G set must be running and the armature loop contactors must be closed. The motor field converter must be turned off so that when motor current flows little or no torque will be produced. It may be necessary to block the motor so that the torque developed from the residual flux will not cause the motor to rotate. It will also be necessary to defeat the field loss function by temporarily setting P082 = 0 (On SIMOREG for generator field).

Proceed with caution during the armature current tuning. Start SIMOREG and make a small current step 0 to 1%. Verify that it does not integrate to a high level. Polarity mistakes at the isolator can result in excessive generator current and possible generator flashing. Adjust the current controller gain, U488, and time constant, U494, to achieve a current rise time, 0 to 63% of final value, of approximately 35 ms. The recommended starting place for the controller gain and time constant are U488 = 0.1, U494 = 0.5 seconds.

Verify the current limit.

When complete reset P082 (on SIMOREG for generator field) to the correct value and switch on SIMOREG for motor field.

8.7 Optimization Speed Controller

The speed controller must be manually tuned. This can be accomplished using the test reference described for the generator field current controller. To perform the speed loop tuning the M-G set must be running and the armature loop contactors must be closed. The motor field converter must be turned on and operating.

Make small command and verify that it does not run away. Adjust speed to reference and make sure speed is correct.

Adjust the speed controller gain, P225, and time constant, P226, to achieve a step speed response rise time, 0 to 63% of final value, of approximately 250 ms. The recommended starting place for the speed controller gain and time constant are P225 = 10, P226 = 0.5 seconds.

Verify operation of the zero voltage regulator with the armature loop contactor closed.

8.8 Motor EMF Controller

The EMF controller and motor field characteristics can be manually tuned or automatically set using the self tuning feature with P051 = 27. When P051 = 27 is used the motor field characteristics will be automatically measured taking approximately 1 minute to complete the measurement. During this procedure the motor will be run up to approximately 80% speed. For that application an analog tachogenerator or pulse generator will be necessary.

8.9 Zero Voltage regulator when Contactor „M“ is Open

After the above adjustments have been made copy function parameter set 1 (FDS1) parameters to FDS2 using P055. Set U488.02 = 1 and U504.02 = 0 and verify operation of the zero voltage regulator with the armature loop contactor open.

