



Leading the World in  
Industrial Networking  
and Communications

## PROFIBUS + PROFINET

Strategic overview

[efesotomasyon.com](http://efesotomasyon.com)

---

### Table of Contents

EXECUTIVE SUMMARY .....	2
PROFIBUS, THE WORLD'S MOST POPULAR FIELDBUS.....	3
<b>PROFIBUS IN ACTION: ADAPTABILITY IN PROCESS AND DISCRETE ENVIRONMENTS</b> .....	5
PROFINET, THE OPEN AND ALL-ENCOMPASSING INDUSTRIAL ETHERNET SOLUTION.....	7
<b>PROFINET IN ACTION: FULL STEAM AHEAD!</b> .....	9
POWERFUL TECHNOLOGIES, COMMON INFRASTRUCTURE, COMMON APPLICATIONS .....	11
<b>PROFIBUS AND PROFINET IN ACTION: HANDLING STEEL COILS SAFELY</b> .....	13
IN PARTNERSHIP, FOR THE FUTURE .....	15

## EXECUTIVE SUMMARY

PROFIBUS, the world's most popular fieldbus has more than 24,000,000 installed devices making it the most successful fieldbus in history. Its comprehensive coverage of automation domains across factory, discrete and process applications makes it ideal for use in all industries.

PROFINET, the open and all-encompassing Industrial Ethernet solution, has many features in common with PROFIBUS, including shared profiles, engineering and support. Its innovative IO solution makes it perfect for modern real-time applications – including advanced Motion Control - while its ability to integrate with higher level networks is ideal for bringing the plant floor into harmony with enterprise-wide IT systems.

PROFINET can integrate PROFIBUS networks easily. It can integrate almost all other existing plant networks too. PROFINET thus provides the ideal way to evolve plant assets and equipment into an Ethernet-based future, without making equipment and skills redundant.

PI, the organization responsible for both PROFIBUS and PROFINET, is the largest of its type in the world. It is made up of 25 regional offices, over 1400 member companies, and a global network of certified support, certification and training operations.

Proven technologies, global support and industry-wide coverage make PROFIBUS and PROFINET the perfect partners for automating all kinds of discrete manufacturing and process automation lines.



## PROFIBUS, THE WORLD'S MOST POPULAR FIELDBUS

PROFIBUS today towers over industrial networking markets with in excess of 24,000,000 million installed nodes - probably more than all its competitors added together. PROFIBUS is the undisputed leader in PLC-based factory automation applications. It also dominates in process automation, with about 4,000,000 installed nodes. The total value of the PROFIBUS market is believed to be \$50Billion, and all indications are that growth will continue. PI expects PROFIBUS to pass 30,000,000 installed nodes before 2010 and for widespread use to continue well after that.

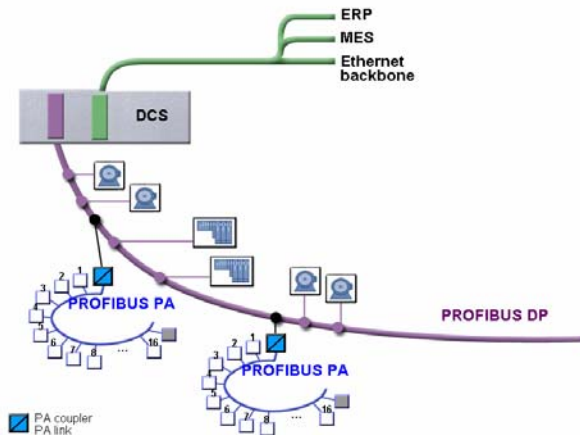

Part of the value proposition of PROFIBUS is its ability to cut costs and improve operations across the life cycle of a plant, from design right through ongoing maintenance and even revamps. It does this in many ways: at the engineering stage it simplifies plant design, eliminates hard wiring and requires less hardware, leading to faster commissioning and lowered costs. It supports better diagnostics, so commissioning is much faster. PROFIBUS also helps achieve better productivity and higher product quality through the delivery of better and more timely data to operations and management staff. In addition,

it supports advanced asset management strategies that allow plants and equipment to be better managed and maintained.

A huge number of vendor companies have developed PROFIBUS-capable devices for discrete and process automation, so system integrators and end users have massive choice. Not only does this lead to security and flexibility of supply; it also means healthy competition amongst vendors, leading to pricing that is highly favorable to end users.

The success of PROFIBUS is underpinned by the global technical and administrative network of PI, which has carefully-managed its development to ensure users' needs continue to be met. The applications coverage has been continuously extended to include new and relevant functionality such as integrated Functional Safety and advanced Motion Control. Users have made substantial investments in training, tools, inventories and plant. In short, the value proposition of PROFIBUS has become commandingly high. That's why PROFIBUS is the most successful fieldbus in history.

### 10 reasons for choosing PROFIBUS

- Preferred fieldbus for most end users and used in the largest number of applications worldwide.
- Huge vendor and product choice.
- Openness and interoperability, allowing changes/updates at low cost
- Protocol optimized for factory and process control using standardized interfaces, and therefore ideal for hybrid applications too.
- Less hardware needed, which means less weight and space also lowered installation and life cycle costs.
- Easy and consistent integration of functional safety and motion control for factory **and** process automation.
- Flexible media redundancy.
- Stringently-managed technology development, including test & certification processes.
- Supported by PI, the world's largest fieldbus organization.
- Easy migration to PROFINET.



## PROFIBUS IN ACTION: ADAPTABILITY IN PROCESS AND DISCRETE ENVIRONMENTS

To meet the increasing demand for mica-based pigments, Merck KGaA of Darmstadt, Germany, recently commissioned a €60 million pigment production facility at its Gernsheim plant. Nearly 2,500 field devices were planned for the new plant.

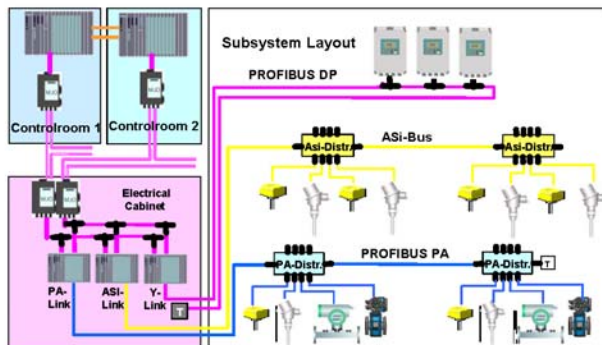

Merck's modular networked architecture uses multiple subsystems consisting of a standardized electrical mini-cabinet containing PROFIBUS DP, PA and AS-i links, local I/O blocks, and power supplies.

Merck's engineers had not previously used fieldbus but they looked at available solutions and chose PROFIBUS. due to the large number of devices available as well as its high rate of acceptance. The need was for a solution that would handle both process and discrete applications without having to use multiple networks. The company claims that no other fieldbus came close to matching PROFIBUS' adaptability in both environments.

Merck's engineers performed a cost analysis, comparing the use of PROFIBUS to hard-wired I/O in terms of device, installation and engineering. While the overall purchase costs of devices and Plant Automation System (PAS) hardware were slightly higher (due to the additional network interface), the analysis concluded that substantial cost savings would be realized. They estimated a 19 percent saving on installation due to the reduced wiring

necessary for networked field devices, and as much as 36 percent on engineering.

PROFIBUS enabled the use of 2-wire networks throughout most of the plant, augmented by fiber optic cabling for noise immunity and ring redundancy. Pre-fabricated cables and T-connectors helped reduce wiring errors as well as speeding up installation. The substantial savings in engineering and shorter planning time resulted from greatly simplified CAD drawings due to the reduced wiring requirements.

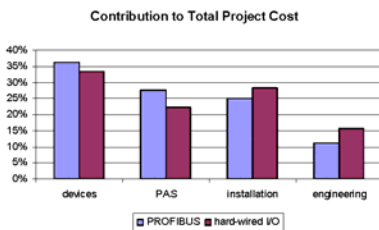

**Using PROFIBUS, installation costs per device were 19 percent lower and engineering costs 36 percent lower than with hard-wired I/O.**

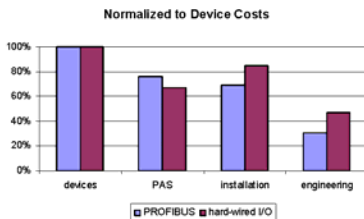

**PROFIBUS' lower installation and engineering costs more than made up the difference for higher purchase costs.**

Source: ARC Advisory

Major cost savings also resulted from the decision to employ a decentralized PROFIBUS architecture of around 60 sub-systems, each comprising a standardized electrical mini-cabinet containing PROFIBUS DP and PA links, local I/O blocks and power supplies. Devices such as drives, field instruments and other I/O devices were connected to redundant PCS 7 controllers via the network. By designing these sub-systems around a standardized PROFIBUS architecture, engineers were able to 'copy and paste' much of the plant design, simplifying the engineering and greatly reducing costs.

Using centrally-located diagnostic and configuration tools, plant engineers can now configure a replacement field device or quickly locate wiring faults from either of two redundant control rooms. The standardized sub-systems support identical wiring in all parts of the plant, meaning shorter downtime during repairs. Finally, when field devices need to be repaired or replaced, most can be 'hot-swapped' without having to shut down the process.



## PROFINET, THE OPEN AND ALL-ENCOMPASSING INDUSTRIAL ETHERNET SOLUTION

If PROFIBUS is so successful in automating factories and process plants, what convincing business advantages does PROFINET offer? The answer is that it draws on the experience of PROFIBUS while opening the way forward to ever more flexible automation strategies, delivering even higher performance and enabling the total integration of manufacturing operations. With PROFINET, enterprise-wide connectivity is a 'given', helping realize big operational benefits and compelling business advantages over the life cycle of a plant.

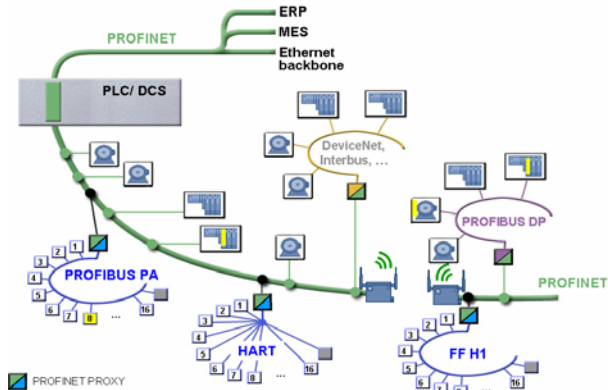

PROFINET is based on the standardized Ethernet used in offices and IT departments, but its move into industrial environments has required care because of the special needs of automation. PROFINET extends basic Ethernet with features that meet the needs of industrial real-time operations and the ruggedization expected by industry.

Technically, Ethernet's larger address space means more devices can be included in plant networks, with almost unlimited scalability. More bandwidth is available too, for data-intensive functions such as machine vision working alongside measurement and control. There's also more capacity for advanced applications like Motion Control.

Ethernet is easily cabled and installed. Many diagnostic tools are available to support PROFINET engineering, network management and maintenance and Internet technologies can be deployed easily. Thus, production enterprises become globally-accessible using standard web browsers. For managers this means better managed facilities that can be fully integrated into the enterprise, enabling faster responses, better productivity and higher profitability.

PROFINET is modular and scalable, so a PROFINET system can be updated at any time. Modularity makes the adoption of PROFINET systems more manageable. It also means they are future proofed, because PROFINET will handle ALL automation and enterprise functions easily.

A unique 'proxy' solution allows PROFIBUS networks – including PROFIBUS PA - to be easily integrated with PROFINET. The 'proxy' solution accommodates other fieldbuses too, for example FOUNDATION Fieldbus, DeviceNet, HART, Interbus and AS-i. In short, existing systems, skills and equipment are protected in any migration to PROFINET.

### **10 reasons for choosing PROFINET**

- All the above reasons for choosing PROFIBUS, plus ...
- Seamless enterprise-wide integration, global accessibility.
- Unlimited node count, powerful capabilities, greater scalability.
- Full TCP/IP, internet and web compatibility, with real-time determinism
- Ethernet cabling eases installation, and familiar IT and Internet tools help during operation, maintenance and diagnostics.
- Wireless and functional safety easily added.
- Protects investments in plant and people by easily integrating all popular automation networks.
- Strategic links with PROFIBUS include common infrastructure, common engineering platforms, common quality assurance and common application profiles.
- Modular, flexible, comprehensive – use only what you need now.
- Easily extended and expanded as enterprise needs change.



## PROFINET IN ACTION: FULL STEAM AHEAD!

eL-Tec Elektrotechnologie, located in Hattem in the Netherlands, is building an alarm system for an extremely luxurious sailing yacht, the 52 meter, single-master 'Boreas'. The company has a lot of experience in control and monitoring systems for ships but up to now has used separate control and service systems. For this ship, a more powerful and extensive system was needed, so the engineering team explored new possibilities. The answer lay with S-MAX, a powerful Phoenix Contact PLC with an integrated touch-screen service panel (HMI) and a PROFINET interface.



Four S-MAX controllers are being used in the 'Boreas'. Using PROFINET these exchange data transparently with other equipment such as the motor management and fire alarm systems. PROFINET is certified for shipping and it handles the data transported between the PLC and the I/O modules and the normal

Ethernet data simultaneously in real-time. The system has the required reaction speed, and it supports very fast visualization. With the HMI integrated into the S-MAX, costs and programming hours are much reduced.

The monitoring system controls and communicates with all vital functions of the ship – the motor, the valves in the bilge pump, fuel and ballast tanks, fresh water tanks, the heating and cooling installations, fire alarms, battery system, the navigation lights and the deck lights.

The simplest, and the most complicated, systems are handled with PROFINET IO, from the dimming of the lights in the accommodation area to the hydraulic system for reefing and hoisting the sails. Everything is done with a strong emphasis on energy saving. An important reason for choosing PROFINET was the savings realised in cabling. The whole system

communicates via one PROFINET fiber network, which delivers a big commercial advantage together with considerable weight savings – important in ship design.

The ship is divided into six segments, each with its own managed PROFINET switch which connects to the I/O devices around the ship. A separate glass fiber cable has been installed which will only be used for this system, and the whole network is tightly secured against interference.

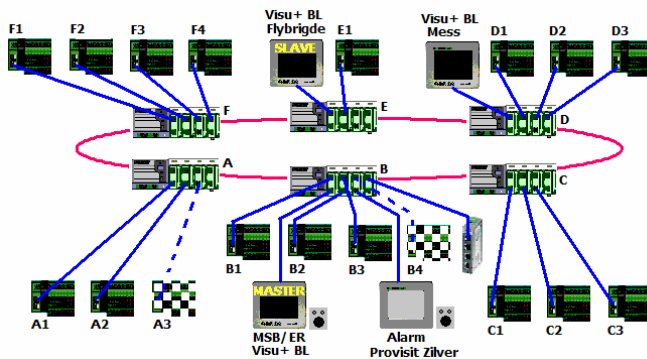

The yacht will sail around the world, so eL-Tec has proposed that a fully redundant system be installed. The primary system would then have a back up, which PROFINET supports easily and without too many extra costs. If the customer agrees, eL-Tec will also implement the software needed to let its support engineers in Hassen help the crew remotely solve any problems that arise via the internet.

## POWERFUL TECHNOLOGIES, COMMON INFRASTRUCTURE, COMMON APPLICATIONS



The synergy between PROFINET and PROFIBUS is based on innovative technology and a high degree of engineering commonality. Both solutions play well together to bring substantial benefits for end users.

PROFIBUS and PROFINET deliver powerful answers to the communications challenges faced by modern manufacturing plants. Both offer genuine real-time capability, plus redundancy for high integrity operations. Both feature IO solutions optimized for factory and process control.

Engineering is replicated as much as possible to enable existing PROFIBUS skills and tools to be re-used with PROFINET. For example, the GSD files used for PROFINET configuration are similar, and handled in the same way, as with PROFIBUS.

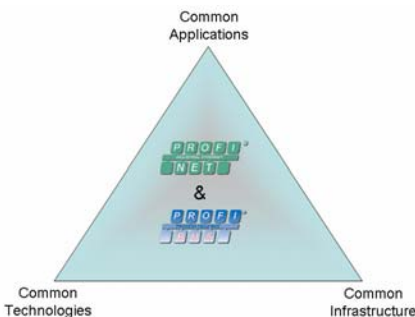

The global infrastructure of PI and its associate organizations underpin the secure investment proposition of PROFIBUS and PROFINET. The PI infrastructure includes the largest Technical Committee hierarchy in this field, with over 550 experts currently supporting PI Working Groups. The global network of

Competence Centers, Training Centers and Test Labs deliver high quality end user training and provide a consistent base for helping vendors develop and certify products.

PI has based many of PROFINET's capabilities on its 20-year experience of PROFIBUS. Common application and device profiles deliver the same functionality and a similar 'look & feel' for both technologies in most applications domains. The goal has been to embrace all applications areas presently served by PROFIBUS.

Both PROFIBUS and PROFINET support process industry needs by ensuring factory and process solutions can be intermingled easily. This recognizes that most process plants today are 'hybrid' – that is, they have discrete manufacturing functions working alongside field-based instrumentation and control. The PROFIBUS PA protocol is exactly the same as the PROFIBUS DP protocol used in factory automation, so engineering, tools and functionality are identical. Only the physical interface is different, because of the need for power-on-the-bus and Intrinsically Safe operations when used in hazardous areas.

For PROFINET, process automation integration is made simple by means of 'proxies', which allow existing fieldbus-based networks to be accommodated easily inside PROFINET architectures. Legacy investments in skills and equipment are fully protected when migrating plants to a PROFINET-based future since PROFIBUS PA can be used unchanged within PROFINET applications.

## PROFIBUS AND PROFINET IN ACTION: HANDLING STEEL COILS SAFELY



ArcelorMittal, the largest steel corporation in the world, recently looked for a safe and reliable automation solution for transporting steel coils at their flat carbon steel products plant in Ghent, Belgium. Coils, which can weigh 30 tons, first need to be lifted safely and securely from incoming rail wagons and then be placed on 'saddles' in the stockyard (a temporary storage area). Later, they are picked up and delivered 'just in time' to the right

production line.

The coils have razor sharp edges and can often be at high temperatures, so there are critical personnel and equipment safety issues to contend with. They are carried by overhead gantry cranes which use 'tongs' to pick a coil. Cranes weigh up to 180 tons and can reach speeds up to 1.6 m/s so, if a safety hazard occurs, a crane must stop immediately. The economic consequences of late or wrong delivery of a coil are also high, as is coil damage. ArcelorMittal's requirement was to transform an existing, 1970's, manually-operated crane into fully automated operation. As well as the safety improvements sought, a Return on Investment (ROI) of less than 2 years was specified along with a robust, reliable and open solution.

One of the first things the crane has to do is locate the exact position of a coil. Coil locations are stored in the company's MES system but minor variations in the actual location of a coil are common. The position of train wagons is also uncertain, so the automated solution has to cope with many variables. This meant building a new system from scratch.

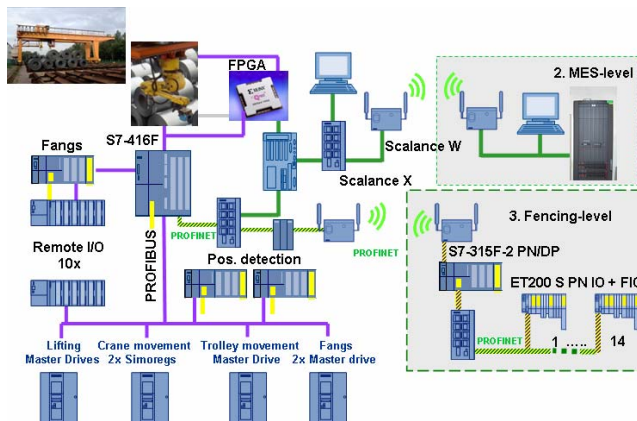

The 'brain' of the chosen solution is an HMI system linked to the company's LAN, and a PLC capable of performing a combination of regular control tasks as well as failsafe functionality. Regular control tasks and safety tasks are handled across PROFIBUS and PROFINET together, using both copper and wireless. The MES database prioritizes all coil movements, transmitting data wirelessly to the crane via the PROFINET network.

To ensure safe operation, the crane has a laser scanner to survey its environment. Data from this scanner is used to create a 3D image of the surroundings, which is stored in an industrial PC on the crane and used to determine if there are any obstacles within operating range. It's also used to pinpoint the exact location of a coil, and it further allows the shape and condition of the coil to be monitored. This can be important if, for example, a coil's seal is broken and a flap is hanging down that could damage other coils or cause mechanical problems elsewhere. The pick-up 'tongs' of each crane are also fitted with sensors to monitor activity, with a local PLC sending data to the failsafe PLC on the crane in case of problems.

To prevent unauthorized access to the stockyard, fences surround the entire area. There are 14 entrances, each fitted with safety interlocks and other sensors linked to a local safety PLC through PROFINET. Whenever a door needs to be opened during crane activity, this safety PLC transmits a signal to the crane's failsafe PLC, stopping all crane activity immediately.

The result at ArcelorMittal is a crane that can perform its task without human intervention thus reducing costs and improving safety for both man and machinery. ArcelorMittal reports that not only was its ROI target met but that the installation was also brought in at minimum cost.

Wireless systems can also be useful when slip-rings are involved because they can eliminate maintenance-intensive mechanical components, significantly improving reliability and delivering big savings.

## IN PARTNERSHIP, FOR THE FUTURE



PROFIBUS is the world's most popular fieldbus, and is used in the largest number of applications and by the most end-users. Its reputation as the 'fieldbus of choice' is unchallenged and its crucial role in automation will continue for many years.

PROFINET and PROFIBUS play well together, with many 'added values' coming from their synergies. Technical overlaps and complementary technologies extend the value proposition. Both PROFIBUS and PROFINET support real-time performance. PROFINET is fully-Ethernet compatible. Further, PROFINET offers unprecedented performance opportunities in Motion Control. Like PI's Functional Safety technology, the Motion Control solution is common to both PROFINET and PROFIBUS.

PROFINET opens the door to new automation opportunities by leveraging the reach and scale of the Web to make managers better informed and plants easier to manage. PROFINET is providing a single point of convergence for enterprise systems and the end-point devices that drive modern automation. PROFINET can support plant-wide Ethernet networks as they are increasingly used for multiple purposes. Yet PROFINET never obsoletes existing systems or equipment.

The modularity of PROFINET means not everything has to be used at once, so there is strong evolutionary energy in a PROFINET solution. Additional devices and functionality can be added easily to meet the advancing needs of plants and enterprises. Migratory options mean that PROFIBUS devices can be used today with the assurance that they will fit in with a PROFINET system later. Other networks can just as easily be integrated too.

With its larger address space, greater bandwidth, enterprise connectivity, and peer-to-peer integration capability PROFINET is on the way to become the leading Industrial Ethernet Standard in automation. However, the conservative nature of manufacturing industry, particularly for process automation, means that PROFIBUS has a secure future. Remember, Ethernet itself is now more than 30 years old.

The success of PROFIBUS is the base on which PROFINET is now building its own success. Market momentum and the credibility provided by PROFIBUS helps this process. The innovative PROFINET solution protects legacy investments and offers an easy migration path. PROFINET is a great partner for PROFIBUS, a factor that will support continued growth for PROFIBUS systems as PROFINET's own popularity grows.

**©2008 PROFIBUS and PROFINET International.** All rights reserved. The PROFINET Logo is a registered trademark. Members of PROFIBUS and PROFINET International are entitled to use the logo in all their written or electronic publications and promotional material. The use of the PROFINET Logo in connection with PROFINET products is allowed only under the conditions of the PROFINET Runtime Software license. All other trademarks and registered trademarks are the property of their respective owners.

**Published by:** PROFIBUS Nutzerorganisation e.V. Haid-und-Neu-Str. 7, 76131 Karlsruhe, Germany.  
Phone: +49 721 / 96 58 590; Fax: +49 721 / 96 58 589; E-mail: info@profibus.com