

Product Information on the Reference Manual

Programmable Logic Controllers S7-300 Module Data Release 3

1 Position Decoder Module SM 338; POS-INPUT; (6ES7338-4BC01-0AB0)

Order number

6ES7338-4BC01-0AB0

Characteristics

The position decoder module SM 338; POS-INPUT is distinguished by the following features:

- 3 inputs for the connection of maximum three absolute value encoders (SSI) and 2 digital inputs to freeze the encoder values
- Direct reaction possible to encoder values in moving systems
- Processing of acquired encoder values of the SM 338 in user program
- Supports clocked operation
- Type of encoder value acquisition (see chapter 1.1.2.1) can be selected:
 - Free running
 - Clocked
- 24 VDC rated input voltage
- Non-isolated against the CPU
- Fast mode selectable; with faster encoder recording and compressed checkback interface

Fast mode is available as of SM 338; POS-INPUT firmware version V2.0.0 and as of STEP 7 V5.3+SP2 selectable.

Supported encoder types

The following encoder types are supported by the SM 338; POS-INPUT:

- Absolute value encoder (SSI) with 13-bit message length
- Absolute value encoder (SSI) with 21-bit message length
- Absolute value encoder (SSI) with 25-bit message length

Supported data formats

The SM 338; POS-INPUT supports the gray code and binary code data formats.

Firmware update¹⁾

You can use STEP 7 HW Config firmware update to load POS-INPUT in the operating system memory of the SM 338 in order to extend the functionality and trouble-shooting.

Note

The old firmware is deleted with the start of the firmware update. If the firmware update is interrupted or canceled for any reason, the SM 338; POS-INPUT is no longer functional. Restart the firmware update and wait until it has been successfully completed.

¹⁾ The function is only possible in distributed configuration if the header module (slave interface) supports the necessary system services

1.1 Synchronous Operation

Warning

The basics of synchronous operation are described in a separate manual.

Hardware requirements

For the synchronous operation of the SM 338, you require:

- CPU which supports clocked operation
- DP master which supports the equidistant bus cycle
- Slave interface (IM 153-x) which supports synchronous operation

Characteristics

Depending on the system parameterization, the SM 338 works in either non-synchronous or synchronous mode.

In synchronous operation, the data exchange between DP master and SM 338 is synchronous to the PROFIBUS DP cycle.

In synchronous operation all 16 bytes of the checkback interface are consistent.

If synchronicity is lost due to faults or failure or delay of Global Control (GC), the SM 338 goes back into synchronous operation in the next cycle without error response.

If synchronicity is lost, the checkback interface is not updated.

1.1.1 Terminal Connection Diagram and Block Diagram

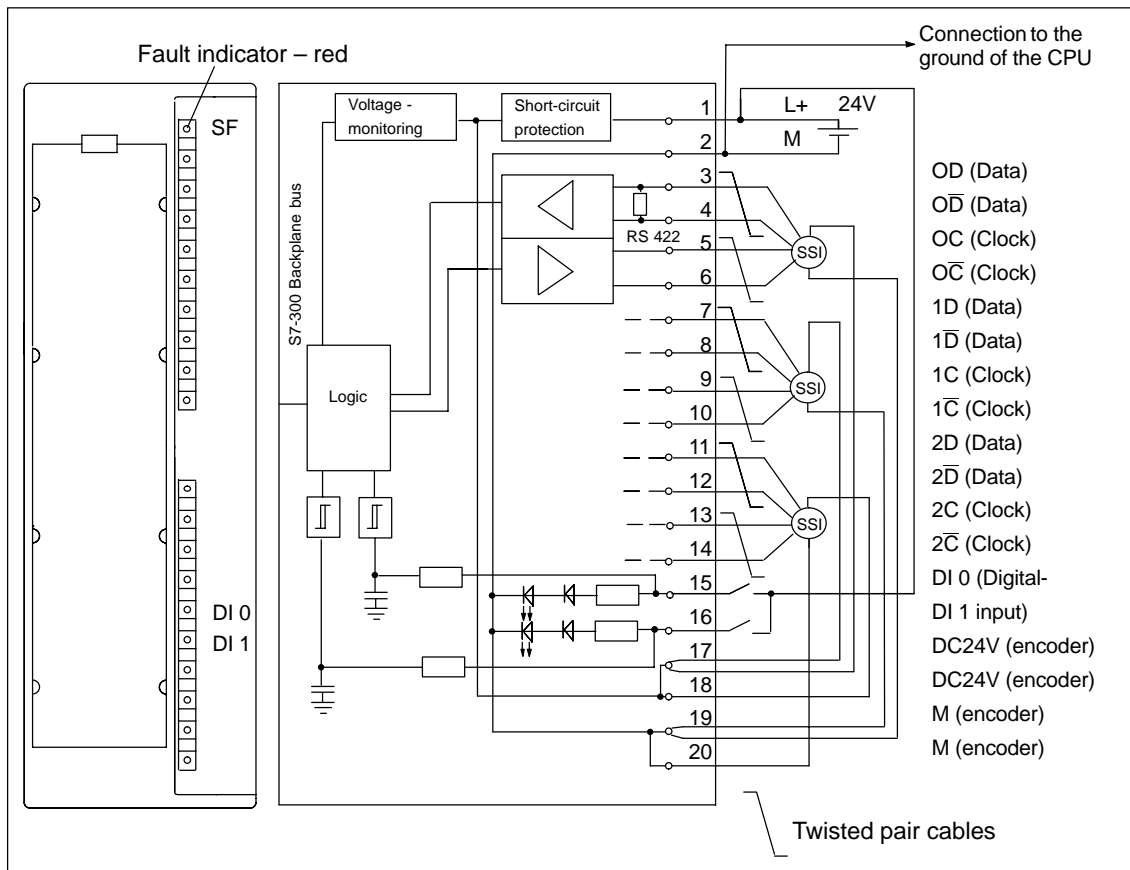

Figure 1-1 Module View and Block Diagram of the SM 338; POS-INPUT

Wiring rules

Please observe the following important rules of the wiring of the module:

- The ground of the encoder supply is connected non-isolated to the ground of the CPU. Thus, connect pin 2 of the SM 338 (M) with low impedance with the ground of the CPU.
- The encoder lines (pins 3 to 14) must be twisted pairs and shielded. Apply the shield to both sides.
For the shield connection to the SM 338, use the shield connection element (order number 6ES7390-5AA00-0AA0).
- If the output current (900 mA) of the encoder supply is exceeded, then you must connect an external power supply.

1.1.2 Functions of the SM 338; POS INPUT

1.1.2.1 Encoder value acquisition

The absolute value encoder transfers its encoder values in messages to the SM 338. The transfer of the message is initiated by the SM 338.

- In non-synchronous operation, the encoder values are acquired while it is free running.
- In synchronous operation the encoder values are acquired synchronized to the PROFIBUS DP cycle at each T_i .

Free running encoder value acquisition

The SM 338 always initiates the transfer of a message after the end of the parameterized monoflop time.

Asynchronous to these free running messages, the SM 338 processes the acquired encoder values during the cycle of its updating rate (see Technical Data).

Thus, in the case of free running encoder value acquisition, encoder values of different ages result. The difference between the maximum and minimum age is the jitter (see Technical Data).

Synchronous encoder values acquisition

Synchronous encoder values acquisition is automatically set if, in the DP master system, the equidistant bus cycle is activated and the DP Slave is synchronized to the DP cycle.

The SM 338 initiates the transfer of a message in each PROFIBUS DP cycle at the time T_i .

Synchronous to the PROFIBUS DP cycle, the SM 338 processes the transferred encoder values.

1.1.2.2 Gray/Dual Converter

In the Gray setting, the encoder values provided by the absolute value encoder in gray code is converted into Dual code. In the Dual setting, encoder values provided by the absolute value encoder remain unchanged.

Warning

If you have selected the Gray setting, the SM 338 always converts the entire encoder value (13, 21, 25 bits). As a result, preceding special bits affect the encoder values and following bits could be falsified under certain circumstances.

1.1.2.3 Transferred Encoder Value and Normalization

The transferred encoder value contains the encoder position of the absolute value encoder. Depending on the encoder used, additional bits which are located before and after the encoder position are also transferred in addition to the encoder position.

So that the SM 338 can detect the encoder position, make the following settings:

- Normalization, places (0..12), or
- Normalization, units / revolution

Normalization, places

The normalization determines the position of the encoder values in the checkback interface.

- If "Places" = 1, 2....12, this indicates that the following non relevant bits in the encoder values are removed and the encoder value is right justified in the address range (see following example).
- If "Places" = 0, this indicates that the following bits are retained and available for evaluation.
This can be useful if you use an absolute value encoder which transfers information in the following bits (see manufacturer information) and you want to evaluate these (see also chapter 1.1.2.2).

Parameter units / revolution

A maximum of 13 bits are available for the units/revolution. According to the "Places" data, the resulting number of units/revolution is automatically displayed.

Example of normalization of an encoder value

You are using a single-turn encoder with 2^9 units= 512 units/ revolution (resolution/360°).

In *STEP 7* you have set the following parameters:

- Absolute encoder: 13 bits
- Normalization: 4 places
- Units / revolution: 512

Before the normalization: cyclically acquired encoder values 100

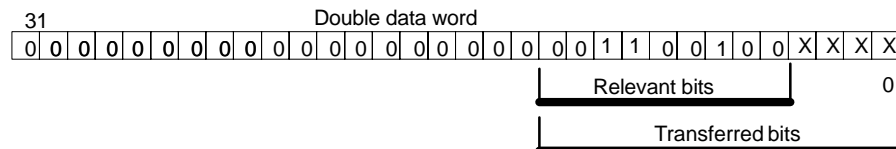

After the normalization: encoder values 100

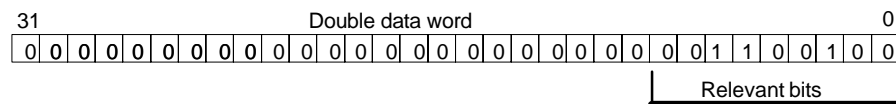

Result: Bits 0 to 3 (4 places, marked with “x”) are omitted.

1.1.2.4 Freeze Function

The freeze function “freezes” the current encoder values of the SM 338. The freeze function is coupled to the digital inputs DI 0 and DI 1 of the SM 338.

The freeze is triggered by an edge change (rising edge) on DI 0 or DI 1. A frozen encoder value is identified by the bit 31 (output address) being set. With a digital input you can freeze one, two or three encoder values.

You must switch on the freeze function, i.e. set the corresponding parameters in *STEP 7*. The freeze function is not possible in fast mode.

The encoder values are retained until the freeze function is ended and can thus be evaluated dependent on the event.

Ending the freeze function

The freeze function must be ended at every encoder input. You acknowledge the function in the user program by setting the bit 0, 1 or 2 depending on the channel with the *STEP 7*-Operation T PAB “xyz” (for a program example, see chapter 1.1.4).

After exiting, bit 31 of the corresponding encoder value is again deleted and the encoder values are again updated. A renewed freezing of the encoder values is again possible as soon as you have deleted the acknowledgment bit in the output address of the module.

In synchronous operation the acknowledgment is processed at time T_0 . From this point in time a renewed freezing of the encoder values can take place via the digital inputs.

Warning

The freeze function is automatically acknowledged if you newly parameterize the corresponding channel with different parameters (see 1.1.3 chapter). If the parameters remain identical, the freeze function remains unaffected.

1.1.3 SM 338; POS-INPUT Parameterization

You parameterize the SM 338; POS-INPUT with *STEP 7*. You must perform parameter assignment in STOP mode of the CPU.

As soon as you have set all the parameters, download the parameters from the programming device to the CPU. On a transition from STOP to → RUN mode, the CPU then transfers the parameters to the SM 338.

The parameters cannot be changed by the user program.

Parameters of the SM 338; POS-INPUT

You will find an overview of the parameters that you can set and their default settings for the SM 338 in the table below.

The default settings apply if you have not performed parameter assignment in *STEP 7* (default setting bold).

Table 1-1 Parameters of the SM 338; POS-INPUT

Parameter	values Range	Note
Enable • Fast mode	Yes/no	Release parameter. Affects all 3 channels.
Enable • Diagnosis interrupt	Yes/no	Release parameter. Affects all 3 channels.
Absolute value encoder (SSI) ¹⁾ Code type ¹⁾ Baud rate ^{1),3)} Monoflop time ^{1),2),3)}	none; 13 bits ; 21 bits; 25 bits Gray ; Binary 125 kHz ; 250 kHz; 500 kHz; 1 MHz 16 µs; 32 µs; 48 µs; 64 µs	none: The encoder input is switched off. Code provided by encoder. Data transfer rate of the SSI position decoder. Observe the relationship between the cable length and baud rate (see Technical Data) The monoflop time is the minimum time interval between 2 SSI message frames. The parameterized monoflop time must always be greater than the monoflop time of the absolute value encoder.
Normalization • Places • Units / revolution ⁴⁾	0 to 12 2 to 8192	Normalizing right justifies the encoder values of the encoder absolute; non-relevant places are discarded.
Switching on freeze	off ; 0; 1	Designation of the digital input whose rising edge causes a freezing of the encoder value.

1) See technical data of the absolute value encoder

2) The monoflop time is the time interval between 2 SSI message frames. The parameterized monoflop time must be greater than the monoflop time of the absolute value encoder (see technical data of the manufacturer). The time $2 \times \times (1 / \text{baud rate})$ is added to the value parameterized in HW config. At a baud rate of 125 kHz with a parameterized monoflop time of 16 µs, an effective monoflop time of 32 µs is actually achieved.

3) The following restriction applies to the monoflop time of the absolute value encoder:
 $(1 / \text{baud rate}) < \text{Monoflop time of the absolute value encoder} < 64 \mu\text{s} + 2 \times \times (1 / \text{baud rate})$

4) to the power of two

Warning

Please note that in non synchronous operation the baud rate and the monoflop time affect the accuracy and actuality of the encoder values.

In synchronous operation the baud rate and the monoflop time affect the accuracy of the freeze function.

1.1.4 SM 338; POS-INPUT Addressing

Data range for the encoder values

The inputs and outputs of the SM 338 are addressed as of the initial module address. The input and output address is determined at the configuration of the SM 338 in *STEP 7*.

Input Addresses

Table 1-2 SM 338; POS-INPUT: Input Addresses

Encoder input	Input address (from the configuration) + address offset
0	"Initial module address"
1	"Module start address" + 4 bytes address offset
2	"Module start address" + 8 bytes address offset

Structure of the double data word in Standard Mode

For each encoder input the double data word is made up as follows:

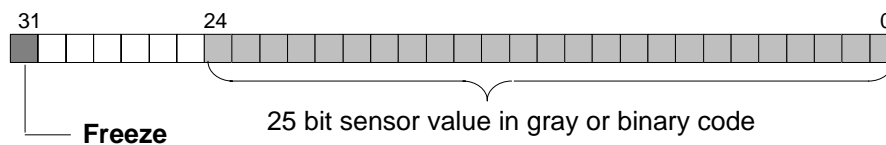

0 = encoder value is not frozen. The value is constantly updated.

1 = encoder value is frozen. The value remains constant until acknowledgment.

Structure of the double data word in Fast Mode

For each encoder input the double data word is made up as follows:

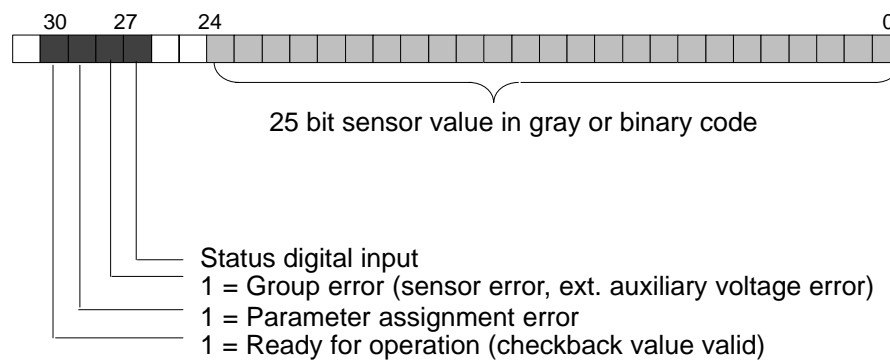

In the double data word of channel 0, the status of the I0 is set in bit 27 (status digital input) and in the double data word of channel 1, the status of the digital input I1 is set.

The bit is always = 0 in the double data word of channel 2.

Output Address im Standard Mode

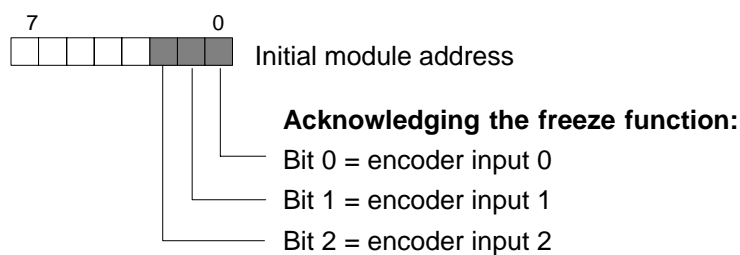

Reading out data areas

You can read out the data areas in your user program with the *STEP 7-Operation* L PED "xyz".

Example of access to encoder values and use of the freeze function

You want to read out and evaluate the value of the encoder at the encoder inputs. The module start address is 256.

No output data are supported in fast mode.

AWL				Explanation
L	PED	256	//	Read encoder value in the address range for encoder input 0
T	MD	100	//	Store encoder value in marker double word
U	M	100.7	//	Acquire and store freeze status for later acknowledgment
=	M	99.0	//	
L	PED	260	//	Read encoder value in the address range for encoder input 1
T	MD	104	//	Store encoder value in marker double word
U	M	104.7	//	Acquire and store freeze status for later acknowledgment
=	M	99.1	//	
L	PED	264	//	Read encoder value in the address range for encoder input 2
T	MD	108	//	Store encoder value in marker double word
U	M	108.7	//	Acquire and store freeze status for later acknowledgment
=	M	99.2	//	
L	MB	99	//	Load and acknowledge freeze condition
T	PAB	256	//	(SM 338: output address 256)

Afterwards you can further process the encoder values from the marker range MD 100, MD 104 and MD 108. The encoder value is contained in bits 0 to 30 of the marker double word.

1.1.5 Diagnosis of the SM 338; POS-INPUT

The SM 338 makes diagnostic messages available, i.e., all diagnostic messages are always provided by the SM 338 without your assistance.

Actions following diagnostic message in *STEP 7*

Each diagnostic message leads to the following actions:

- The diagnostic message is entered in the diagnosis of the module and forwarded to the CPU.
- The SF LED on the module lights.
- If you have programmed "Enable Diagnostic Interrupt" in *STEP 7*, a diagnostic interrupt is triggered and OB 82 is called.

Reading out diagnostic messages

You can read out detailed diagnostic messages by means of SFCs in the user program (refer to the Appendix "Diagnostic Data of Signal Modules").

You can view the cause of the error in *STEP 7*, in the module diagnosis (refer to online Help for *STEP 7*).

Diagnostic message via SF LED

The SM 338 indicate errors for you by means of their SF LED (group error LED). The SF LED lights as soon as a diagnostic message is triggered by the SM 338. It goes out when all errors have been rectified.

The group fault (SF) LED also lights up in case of external errors (short circuit of encoder supply), independent of the operating status of the CPU (if power is on).

The SF LED lights up temporarily at startup during the self test of the SM 338.

Diagnostic messages of the SM 338; POS INPUT

The table below gives an overview of the diagnostic messages for the SM 338.

Table 1-3 Diagnostic messages of the SM 338; POS INPUT

Diagnostics Message	LED	Scope of the Diagnostics
Module problem	SF	Module
Internal malfunction	SF	Module
External malfunction	SF	Module
Channel error present	SF	Module
External auxiliary supply missing	SF	Module
Module not parameterized.	SF	Module
Wrong parameters	SF	Module
Channel information available	SF	Module
Time monitoring triggered	SF	Module
Channel error present	SF	Channel (encoder input)
Configuring/parameter assignment error	SF	Channel (encoder input)
External channel error (encoder fault)	SF	Channel (encoder input)

Causes of errors and remedial measures

Table 1-4 Diagnostics Messages of the SM 338, Causes of Errors and Remedial Measures

Diagnostics Message	Possible Error Cause	Remedy
Module fault	An error detected by the module has occurred.	
Internal error	Module has detected an error within the automation system.	
External error	Module has detected an error outside of the automation system.	
Channel error present	Indicates that only specific channels are faulty.	
External auxiliary supply missing	The power supply L+ to the module is missing	Feed supply L+
Module not parameterized	Module requires information whether it should work with parameters preset by the system or with your parameters.	Message present after network active until transfer of the parameters by the CPU complete; parameterize module if necessary.
Wrong parameters	One parameter or the combination of parameters is not plausible	Reassign module parameter
Channel information present	Channel error present; module can provide additional channel information.	
Watchdog tripped	Temporary high electromagnetic interference	Eliminate interference
Channel error present	An error detected by the module has occurred at the encoder input.	
Configuration / parameterization error	Illegal parameter had been transferred to module	Reassign module parameter
External channel error (encoder error)	Broken wire in encoder cable, encoder cable not connected or encoder defective.	Check connected encoder

1.1.6 Interrupts of the SM 338; POS INPUT

Introduction

In this Section, the interrupt behavior of the SM 338; POS-INPUT is described. The SM 338 can trigger diagnostic interrupts.

The OBs and SFCs mentioned below can be found in the online Help for *STEP 7*, where they are described in greater detail.

Enabling interrupts

The interrupts are not preset – in other words, they are inhibited without appropriate parameter assignment. Assign parameters to the Interrupt Enable in *STEP 7* (refer to Section 1.1.3).

Diagnostic interrupt

If you have enabled diagnostic interrupts, then incoming active error events (initial occurrence of the error) and departing error events (message after troubleshooting) are reported by means of interrupts.

The CPU interrupts execution of the user program and processes the diagnostic interrupt block (OB 82).

In the user program, you can call SFC 51 or SFC 59 in OB 82 to obtain more detailed diagnostic information from the module.

The diagnostic information is consistent until such time as OB 82 is exited. When OB 82 is exited, the diagnostic interrupt is acknowledged on the module.

1.1.7 Technical Specifications of the 338; POS-INPUT

Dimensions and Weight	
Dimensions B x H x T (mm)	40 x 125 x 120
Weight	Approx. 235 g
Voltages, Currents, Potentials	
Rated load voltage L+	24 VDC
<ul style="list-style-type: none"> Range 	20.4 ... 28.8 V
<ul style="list-style-type: none"> Reverse polarity protection 	No
Isolation	no, only against shield
Permitted potential difference	1 VDC
<ul style="list-style-type: none"> between input (M connection) and central grounding point of the CPU 	
Encoder supply	
<ul style="list-style-type: none"> Output voltage 	L+ -0.8 V
<ul style="list-style-type: none"> Output current 	max. 900 mA, short circuit-proof
Current dissipation	
<ul style="list-style-type: none"> From the backplane bus 	max. 160 mA
<ul style="list-style-type: none"> From the load voltage L+ (no load) 	max. 10 mA
Power dissipation of the module	typ. 3 W
Encoder inputs POS INPUT 0 to 2	
Position decoding	absolute
Difference signals for SSI data and SSI clock	according to RS422
Data transfer rate and cable length of absolute value encoders (twisted pair and shielded)	<ul style="list-style-type: none"> 125 kHz max. 320 m 250 kHz max. 160 m 500 kHz max. 60 m 1 MHz max. 20 m
Message duration of the SSI transmission	13 bits 21 bits 25 bits
<ul style="list-style-type: none"> 125 kHz 	112 μs 176 μs 208 μs
<ul style="list-style-type: none"> 250 kHz 	56 μs 88 μs 104 μs
<ul style="list-style-type: none"> 500 kHz 	28 μs 44 μs 52 μs
<ul style="list-style-type: none"> 1 MHz 	14 μs 22 μs 26 μs
Monoflop time ²	16 μs, 32 μs, 48 μs, 64 μs

Digital inputs DI 0, DI 1	
Isolation	no, only against shield
Input voltage	0-Signal: -3 V ... 5 V 1-Signal: 11 V ... 30.2 V
Input current	0-Signal: ≤ 2 mA (quiescent current) 1-Signal: 9 mA (typ.)
Input delay	0 > 1: max. 300 μs 1 > 0: max. 300 μs
Maximum repeat frequency	1 kHz
Connection of a two-wire BEROS, type 2	Possible
Shielded line length	600 m
Unshielded line length	32 m
Status, Interrupts, Diagnostics	
Interrupts	
<ul style="list-style-type: none"> Diagnostic interrupt 	Parameters can be assigned
Status display of digital inputs	LED (green)
Group error/fault	LED (red)
Inaccuracy of the encoder value	
Free running encoder value acquisition (Standard Mode)	
<ul style="list-style-type: none"> Maximum age ¹⁾ 	(2 × Message duration) + monoflop time + 580 μs
<ul style="list-style-type: none"> Minimum age ¹⁾ 	Message duration + 130 μs
<ul style="list-style-type: none"> Jitter 	Message duration + monoflop time + 450 μs
Update rate	Evaluation of the message every 450 μs
Free-wheeling sensor value detection (Fast Mode)	
<ul style="list-style-type: none"> Maximum age ¹⁾ 	(2 × Message duration) + monoflop time + 400 μs
<ul style="list-style-type: none"> Minimum age ¹⁾ 	Message duration + 100 μs
<ul style="list-style-type: none"> Jitter 	Message duration + monoflop time + 360 μs
Update rate	Evaluation of the message every 360 μs
Synchronous encoder value acquisition	
<ul style="list-style-type: none"> Age 	Encoder value at time T _i of the current PROFIBUS DP cycle

Inaccuracy of the frozen encoder value (freeze)	
Free running encoder value acquisition	
• Maximum age ¹⁾	(2 × Message duration) + monoflop time + 580 μs
• Minimum age ¹⁾	Message duration + 130 μs
• Jitter	Message duration + monoflop time + 450 μs
Synchronous encoder value acquisition	
• Jitter	Max (message duration _n + param. Monoflop time _n) n = 0, 1, 2, (Channel)

Isochrone time of the module		
In Standard Mode	TWE	850 μs
	TWA	620 μs
	ToiMin	90 μs
	TDPMIn	1620 μs
In Fast Mode	TWE	700 μs
	TWA	0 μs
	ToiMin	0 μs
	TDPMIn	900 μs

- 1) Age of the encoder values determined by the transfer process and the processing
- 2) The following restriction applies to the monoflop time of the absolute value encoder:
 $(1 / \text{baud rate}) < \text{Monoflop time of the absolute value encoder} < 64 \mu\text{s} + 2 \times (1 / \text{baud rate})$