



**Communication Settings for  
Siemens S7-200 (CPU 212)**

**and**

**IDEC Touchscreens  
(5.7" HG2F, 10.4" HG3F, 12.1" HG4F)**

**Introduction**

The information here will help you configure IDEC touchscreens (5.7” HG2F, 10.4” HG3F, or 12.1” HG4F) and the Siemens S7-200 PLC using S7-200(PPI) protocol. For other supported Siemens PLCs and communication settings/range of addresses, please refer to the WindO/I-NV2 manual (click the link below). Select “Host Interface,” then Connection to a PLC.

<http://www.idec.com/Products/ENG/PDF/manuals/WindOI/V282/English/mainmenu.pdf>

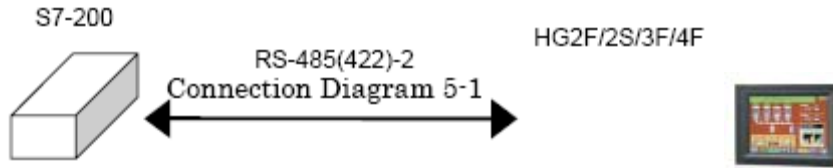

**Cable information between S7-200 (CPU 212) to HG2F/3F/4F**

Part number: HG9Z-2C155A

Wiring Diagram:

S7-200 (RS-485) to HG2F/2S/3F/4F

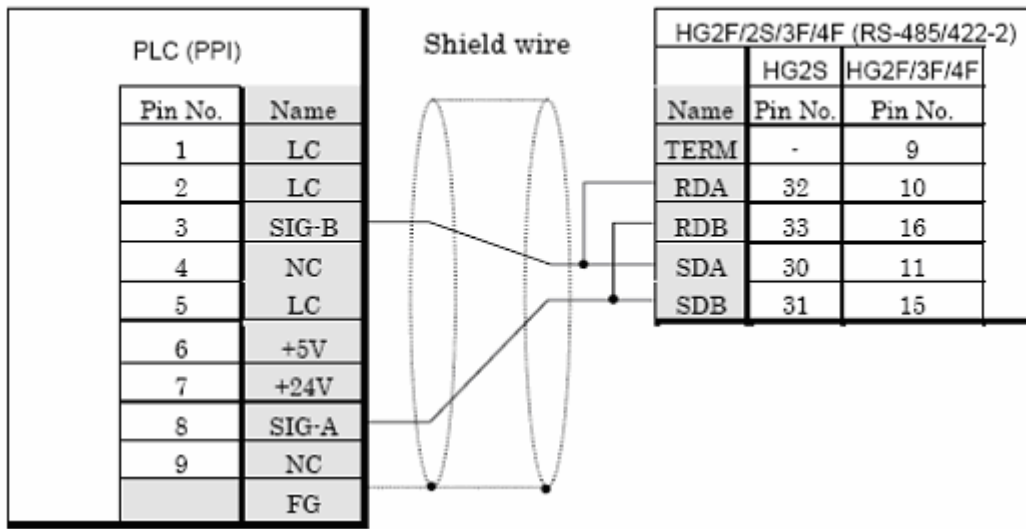

9 Pin Male Connector

25 Pin Male Connector

## Communication Settings

### 5.4.1 S7-200

The communication port settings for S7-200 and HG series host port are as follows.

Items	Details
PLC Address	1 to 126(Dec) (0 to 7e (Hex) ) Set the value to same value as ADDRESS(PLC) in WindO/I-NV2.
Highest Address (Highest Station Address)	1 to 126(Dec) (0 to 7e(Hex) ) Set the value to same value as HSA in WindO/I-NV2.
Baud Rate(bps)	9600 / 19200 Set the value to same value as Baud Rate in WindO/I-NV2.
HG Address	0 to 7e (Hex) (0 to 126(Dec) ) Set the value as ADDRESS(HG) in WindO/I-NV2.
Data Bits(bit)	8 (fixed) Set the value in WindO/I-NV2.
Parity	EVEN (fixed) Set the value in WindO/I-NV2.
Stop bit(bit)	1 (fixed) Set the value in WindO/I-NV2.



- Set the communication port that communicates with HG2F/2S/3F/4F to PPI/Slave mode. Please make sure to set SMB30 or SMB130 values to 0 in order to select proper communication port settings. Refer to the manual of S7-200 for details.
- We checked the following problems in some versions of S7-200.  
When S7-200 is set as the master and the address of S7-200 is the same as HSA, token path does not work correctly.  
This problem can be solved by setting HSA as a larger value than Address actually used.  
This problem does not occur when one HG2F/2S/3F/4F is connected to one S7-200 PLC.

## Available Addressing

### S7-200

#### Bit Device

Device Name	HG Device Symbol	PLC Device Symbol	Address range	Read /Write	Address Gradual
Variable memory	V	V	0 to 102397	R/W	(*1)
Process-image-input-register	I	I	0 to 157	R	(*1)
Process-image-output-register	Q	Q	0 to 157	R/W	(*1)
Bit memory	M	M	0 to 317	R/W	(*1)
Special Memory	SM	SM	0 to 5497	R	(*1)
Timer (Bit)	T	T	0 to 255	R	Dec
Counter (Bit)	C	C	0 to 255	R	Dec
Sequential control relay	S	S	0 to 317	R/W	(*1)

#### ● Word Device

Device Name	HG Device Symbol	PLC Device Symbol	Address range	Read /Write	Address Gradual
Variable memory	VW	VW	0 to 10238	R/W	(*2)
Timer (Current Value)	TW	T	0 to 255	R/W	Dec
Counter (Current Value)	CW	C	0 to 255	R/W	Dec
Process-image-input-register	IW	IW	0 to 14	R	(*2)
Process-image-output-register	QW	QW	0 to 14	R/W	(*2)
Bit memory	MW	MW	0 to 30	R/W	(*2)
Special Memory	SMW	SMW	0 to 548	R	(*2)
Analog input	AIW	AIW	0 to 62	R	(*2)
Analog output	AQW	AQW	0 to 62	R/W	(*2)
Sequential control relay	SW	SW	0 to 30	R/W	(*2)
High speed counter	HC	HC	0 to 51	R	(*3)



- The devices (V, I, Q, M, SM, S) which include a period in the address in S7-200 are written without a period in HG2F/2S/3F/4F.
- For example, V10.1 is written as V101 in HG2F/2S/3F/4F.
- AC(Accumulator registers),L(Local memory) of PLC Devices can not use in HG2F/2S/3F/4F.  
The value of High speed counter which is a double word value is divided into two, and is treated as WORD device in HG2F/2S/3F/4F.  
The higher word is written by adding 0 to the lowest digit of the address, the lower word is written by adding 1 to the lowest digit of the address.  
For example, the lower word of HC1 is written as HC11 in HG2F/2S/3F/4F.  
If you read in a double word value, The lowest digit of the address write 0 . For example, HC2 is written as HC20 in HG2F/2S/3F/4F.

- (\*1) The 1st figure is written with the number of octal number,  
and the 2nd [ or more ] figure is written with the number of decimal.
- (\*2) Only even number can be specified.
- (\*3) The 1st figure is written with the number of binary number,  
and the 2nd [ or more ] figure is written with the number of decimal.

## Requirements for testing

1. Cable part no. HG9Z-XCM1A (programming cable between PC and HG2F/3F/4F)
2. Cable part no. HG9Z-2C155A (cable between Siemens S7-200 and HG2F/3F/4F)
3. Cable part no. PC/PP1 ( programming cable between PC and Siemens S7-200 )
4. HG9Y-ZSS2W (WindO/I-NV2 programming software for HG2F/3F/4F)
5. Siemens programming software called Step 7 Micro/WIN 32 (Windows-based )

## Step 1: Software for Siemens S7-200 (Step 7 Micro/Win 32)

1. Siemens PLC used in this program: S7-200 CPU212
  - a) Connect part number PC/PPI cable from PC to Siemens S7-200.  
The cable dip switches are set to 1=off, 2=on, 3=off, 4=off, 5=off.
2. Launch Siemens programming software.
3. Select PLC – Type.
4. Next, click on the Read PLC button to read your PLC type.
5. Click on the Communications button and the settings should appear.

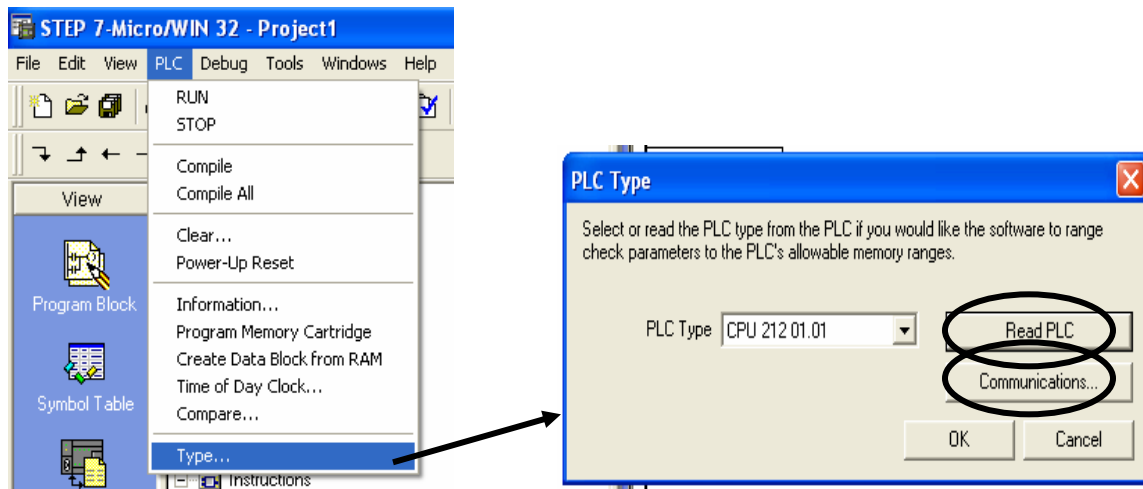

6. Assign the Remote Address ( in this testing, #2 is assigned).

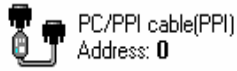

7. Double click

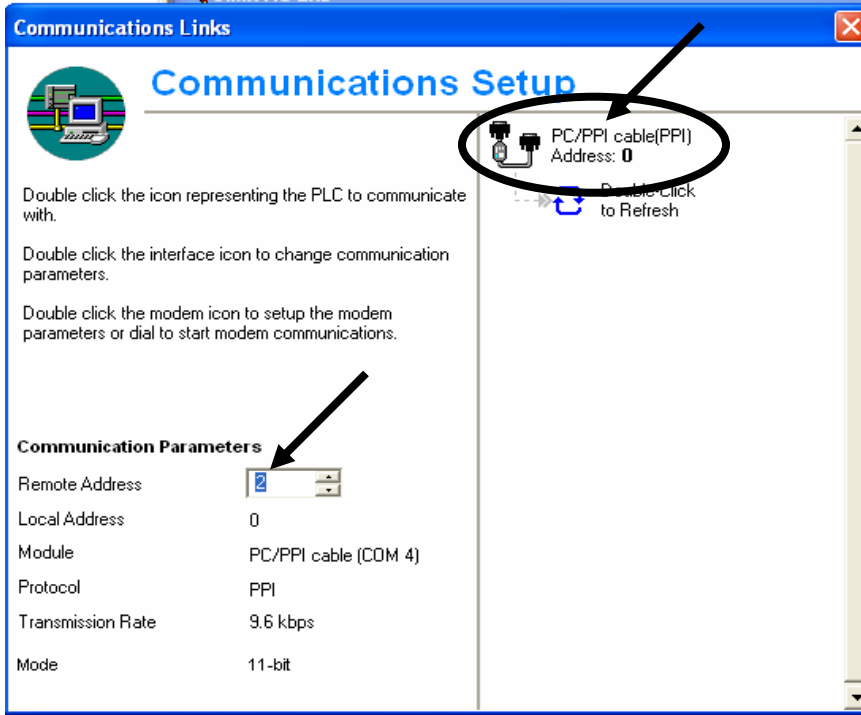

8. In the Access Path, select PC/PPI cable (PPI).  
a) Click the Properties button.

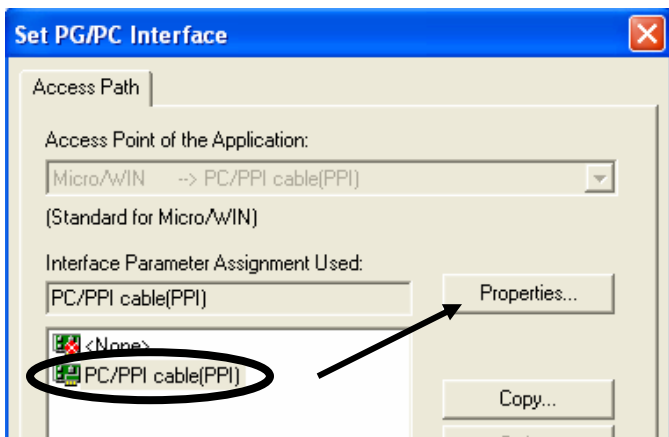

9. Local Connection:

- a) Assign the COM Port. Check your COM port before assigning the number.

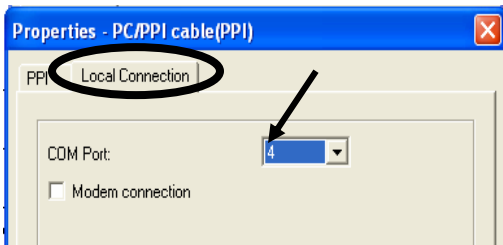

10. PPI :

- a) Assign the station address (#0 is assigned for this test)
- b) Set the transmission rate at 9.6kbps
- c) Highest node address is 31
- d) Click the OK button to exit from the Properties dialogue box

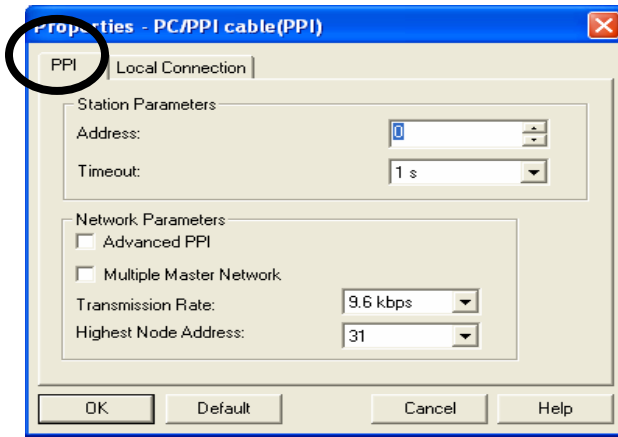

11. Now, create a simple logic by clicking on the normally open contact / output coil

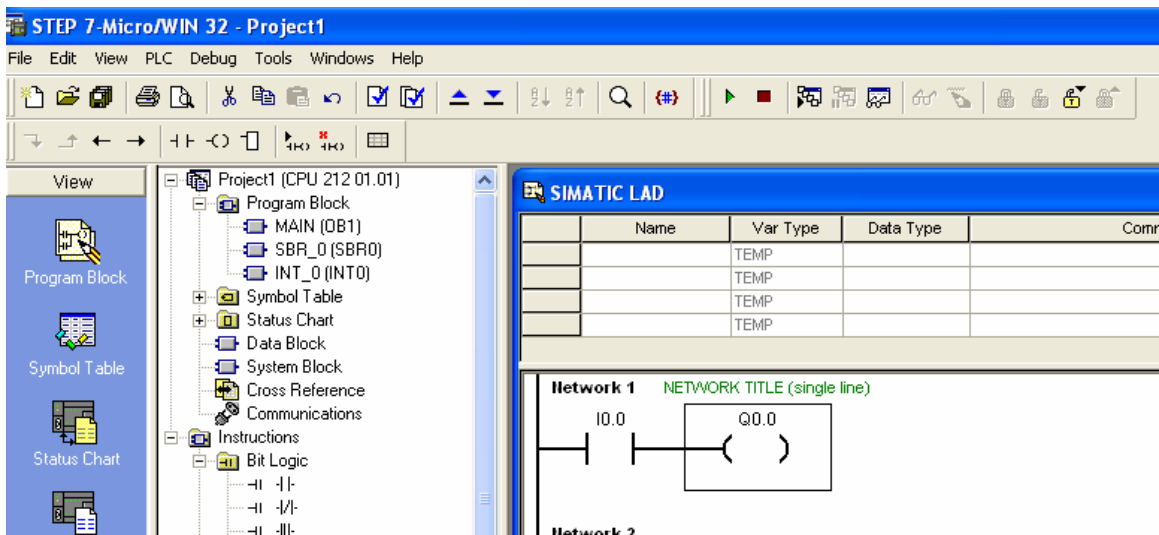

12. Download the project by selecting File-Download.

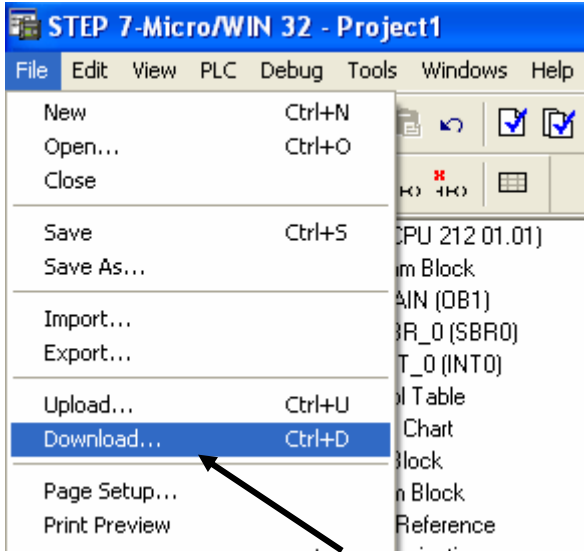

13. In the Download dialog box, follow all settings as shown in the image below and then click the OK button to download.

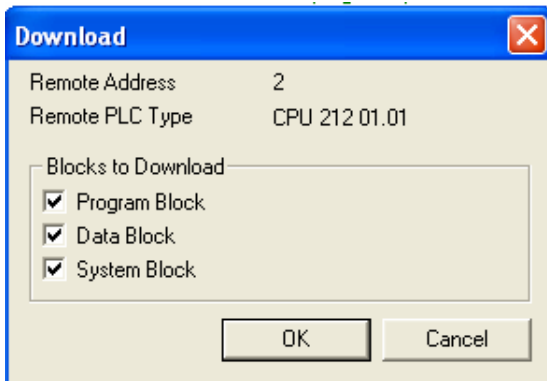

### Step 2: WindO/I-NV2 Software

1. Connect programming cable to PC and HG2F/3F/4F
2. Launch WindO/I-NV2
3. Select File/New Project

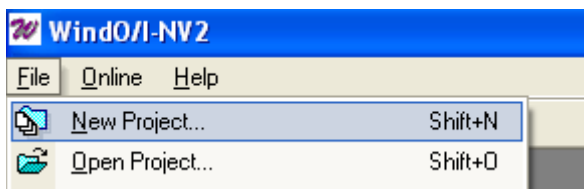

4. Create a project name. In this example, the project name is Siemens HG program. Select the Next button to continue. It will tell you to “create project.” Select the OK button.

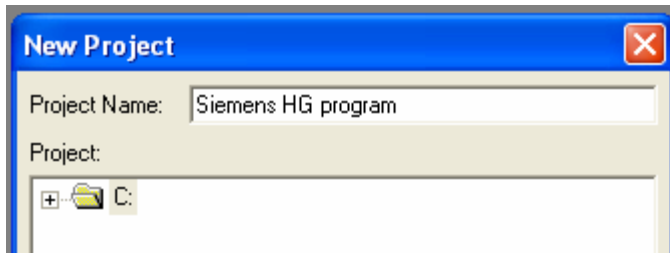

5. Select the O/I and Model type. For testing purposes, HG2F is selected. Select the Next button to continue.

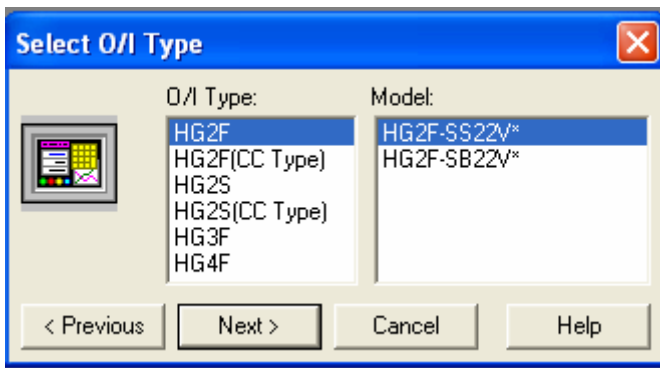

6. In the Host I/F Driver, Siemens is selected for manufacturer and S7-200(PPI) for protocol. Click the OK button.

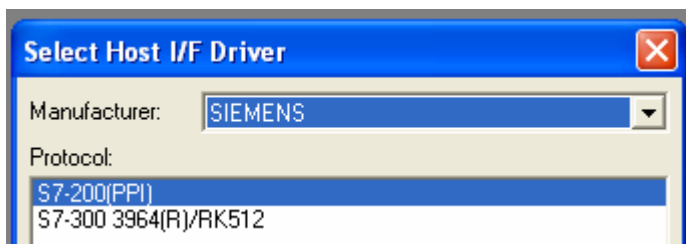

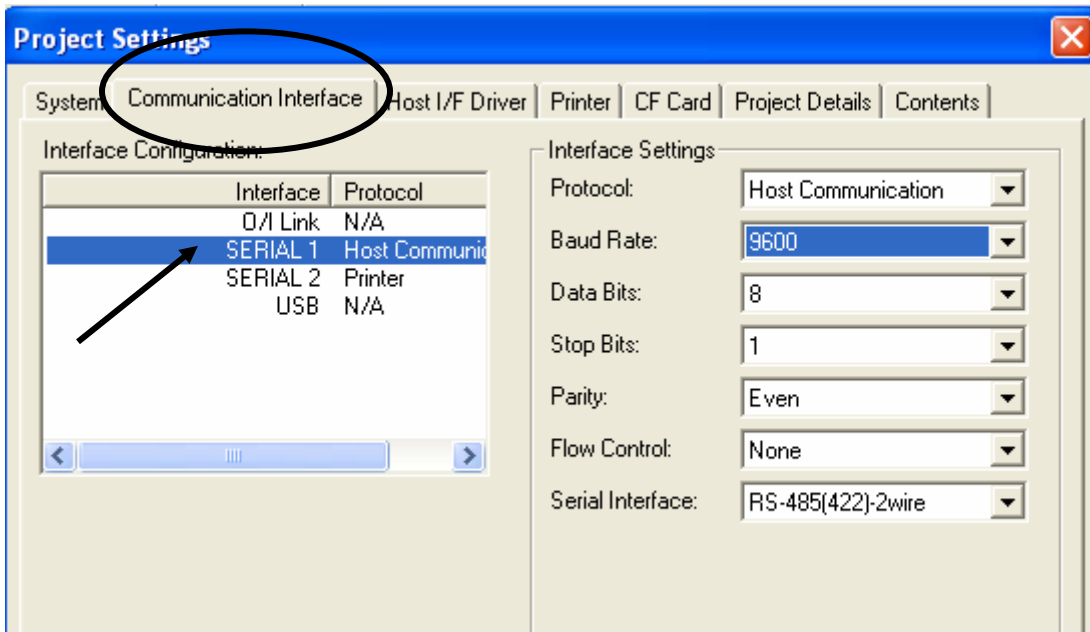

7. In the Project Settings, select the Communication Interface tab.
  - Under the Interface Configuration, select Serial 1 Host Communication.
  - The Interface Settings are shown in the image below.

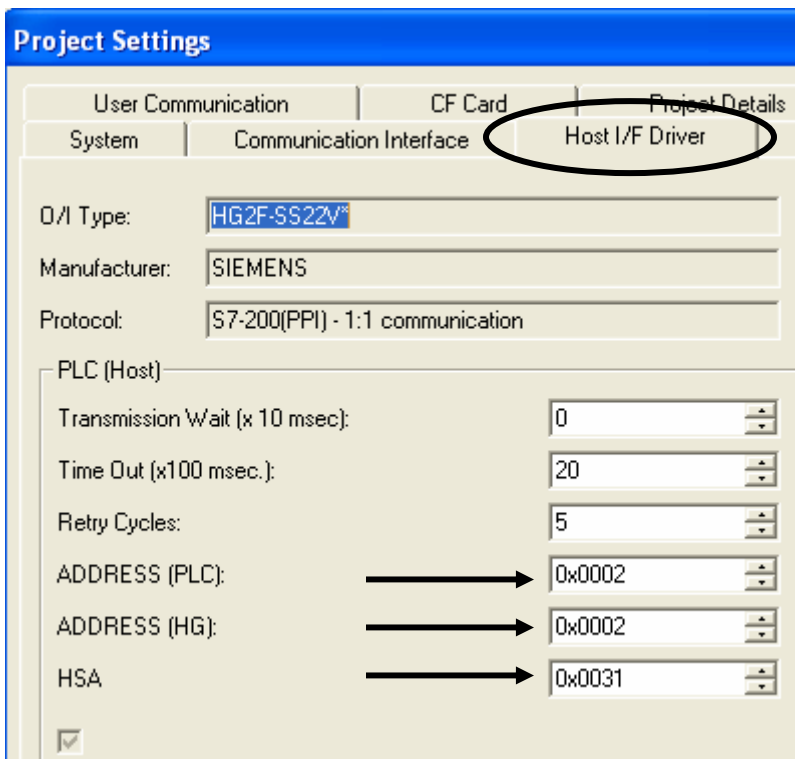

7. Next, select the Host/IF Driver tab. Make sure the settings in the Address [PLC], Address [HG] and HSA match with the settings in the Siemens PLC. In this example, the Address PLC and HG are assigned #2 and the HSA is # 31. These are the settings from the PLC (see Step 7 & 10 above).

8. Select OK button to continue.



9. In Base Screen 1, select Pilot Lamp device  and drop it on the screen. Double click on the device to set the properties. In the General tab under Operation Mode, select No Blink.

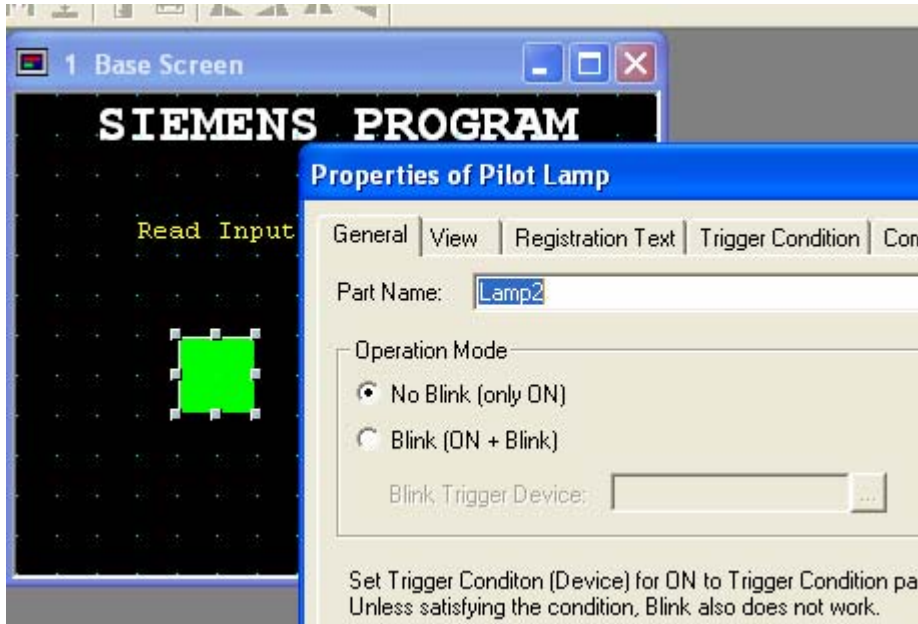

10. In the Trigger Condition tab, select While ON and for Device select I0.

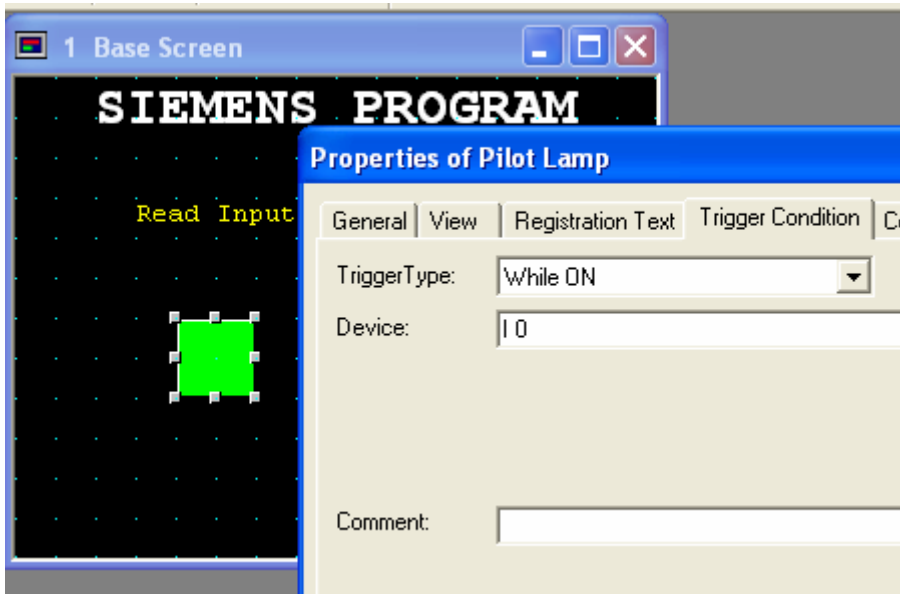

11. Once the settings are done, select the OK button to exit.
12. DOWNLOAD the project to the HG2F/3F/4F. Select Online-Download.
13. Now connect cable partnumber HG9Z-2C155A between the HG2F/3F/4F to Siemens PLC.

If you are able to view the pilot lamp switching on/off based on the Input from the PLC then the communication is successful. You may now continue with your project.

[efesotomasyon.com](http://efesotomasyon.com)

---