

MICRO MASTER Junior

Operating Instructions



WARNING

This equipment contains hazardous voltages and controls hazardous rotating mechanical parts. Loss of life, severe personal injury or property damage can result if the instructions contained in this manual are not followed.

Only suitable qualified personnel should work on this equipment, and only after becoming familiar with all safety notices, installation, operation and maintenance procedures contained in this manual. The successful and safe operation of this equipment is dependent upon its proper handling, installation, operation and maintenance.

The MICRO MASTER Junior operates at high voltages.

Only permanently-wired input power connections are allowed. This equipment must be grounded (IEC 536 Class 1, NEC and other applicable standards). Machines with a three phase power supply must not be connected to a supply via an ELCB (Earth Leakage Circuit-Breaker - see DIN VDE 0160, section 6.5). The power and motor terminals (see Fig. 2) can carry dangerous voltages even if the inverter is inoperative.

Only qualified personnel may connect, start the system up and repair faults. These personnel must be thoroughly acquainted with all the warnings and operating procedures contained in this manual.

Certain parameter settings may cause the motor to restart automatically upon restoration of power after a mains failure.

This equipment must not be used as an 'emergency stop' mechanism (see EN 60204, 9.2.5.4).

- (3) Wherever possible, use screened leads for connections to the control circuitry. Terminate the ends of the cable neatly, ensuring that long strands of unscreened wire are not left visible.
- (4) Separate the control cables from the power connections as much as possible, using separate trunking, etc. If control and power cables cross, arrange the cables so that they cross at 90° if possible. Also ensure that the mains input cables are kept separate from the motor output cables.
- (5) Ensure that contactors in the cubicle are suppressed, either with R-C suppressors for AC contactors or 'flywheel' diodes for DC contactors, **fitted to the coils**. Varistor suppressors are also effective. This is particularly important if the contactors are controlled from the relay on the inverter.
- (6) Use screened or armoured cables for the power connections and ground the screen at the earthing points on the inverter (see Fig. 2).
- (7) Select the lowest switching frequency possible. This will reduce the amount of EMI generated by the inverter.

On no account must safety regulations be compromised when installing inverters!

INSTALLATION

WARNING

To guarantee the safe operation of the equipment it must be installed and commissioned by qualified personnel only.

Take particular note of the general and regional installation and safety regulations regarding work on high voltage installations (e.g. VDE), as well as the relevant regulations regarding the correct use of tools and personal protective gear.

Make sure that the unobstructed clearance for each of the cooling inlets and outlets above and below the inverter is at least 100 mm.

Ensure that the temperature does not exceed the specified level when the inverter is installed in a cubicle.

Avoid excessive vibration and shaking of the equipment.

Mechanical Installation

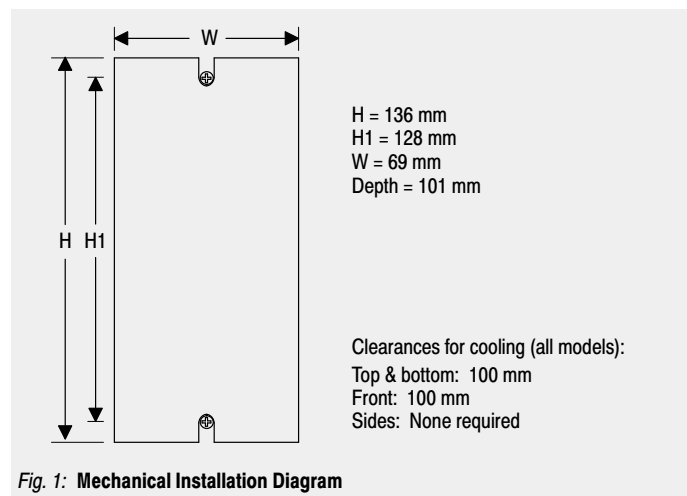

Fig. 1: Mechanical Installation Diagram

Wiring Guidelines

The inverters are designed to operate in an industrial environment where a high level of Electro-Magnetic Interference (EMI) can be expected. Usually, good installation practices will ensure safe and trouble-free operation. However, if problems are encountered, the following guidelines may prove useful. In particular, grounding of the system 0V at the inverter, as described below, may prove effective.

- (1) Ensure that all equipment in the cubicle is well earthed using short, thick earthing cable connected to a common star point or busbar. It is particularly important that any control equipment that is connected to the inverter (such as a PLC) is connected to the same earth or star point as the inverter via a short, thick link. Flat conductors (e.g. metal brackets) are preferred as they have lower impedance at high frequencies.

The return earth from motors controlled by the inverters should be connected directly to the earth connection (PE) on the associated inverter.

- (2) Use saw-tooth washers when mounting the inverter and ensure that a good electrical connection is made between the heatsink and the panel, removing paint if necessary.

Electrical Installation

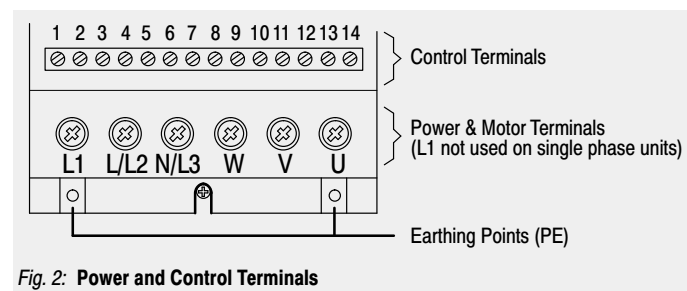

Fig. 2: Power and Control Terminals

CAUTION

The control and power supply cables must be laid separately. They must not be fed through the same cable conduit/trunking.

Power and Motor Connections

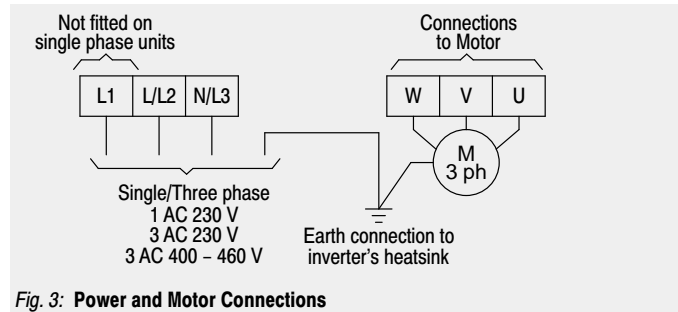

Fig. 3: Power and Motor Connections

WARNING

Ensure that motor is configured for the correct supply voltage. **Do not connect 230 V inverters to a 400 V mains supply.**

Use Class 1 60/75°C copper wire only.

Use a 4-core screened cable.

The total length of the motor lead should not exceed 50 m. If a screened motor lead is used or if the cable channel is well grounded, the maximum length should be 25 m. Consult your service department if you wish to use longer leads.

Asynchronous and synchronous motors can be connected to the inverter either individually or in parallel. Note that if a synchronous motor is connected to the inverter, the motor current may be two and a half to three times greater than that expected.

Use a 4 - 5 mm cross-tip screwdriver to tighten the power terminal screws.

Control Cable Connections

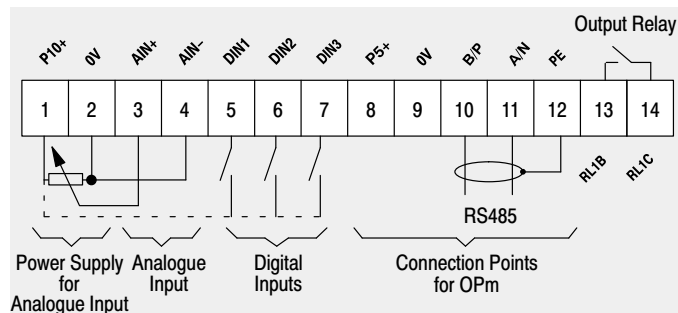

Fig. 4: Control Terminal Connections

Terminal	Description	Value	Function	Notes
1	P10+	+10 V	Power supply	Max. 5 mA
2	0V	0 V	Power supply	Ground
3	AIN+	0/2 - 10 V	Analogue input	+ connection
4	AIN-		Analogue input	- connection
5	DIN1		Digital input 1	7.5 - 33 V, max. 5 mA
6	DIN2		Digital input 2	7.5 - 33 V, max. 5 mA
7	DIN3		Digital input 3	7.5 - 33 V, max. 5 mA
8	P5+		Power supply	max. 250 mA
9	0V		Power supply	Ground
10	B/P		RS485 'B' (+)	For USS protocol
11	A/N		RS485 'A' (-)	For USS protocol
12	PE		Protective earth	
13	RL1B		Relay 1	Normally open 30 V dc / 1.0 A max.
14	RL1C		Relay 1	Common

Use a small blade screwdriver (2 - 2.5 mm) to tighten the control terminal screws.

FRONT PANEL CONTROLS

WARNING

After the power has been turned off, you must always wait five minutes so that the dc-link capacitors can discharge. As a precautionary measure, the digital frequency setpoint has been set at 0.0 Hz in the factory. This prevents inadvertent and uncontrolled running of the motor occurring at initial start-up. Before the motor will run it is necessary to enter a frequency setpoint via parameter P000 with the Δ button, or to set it with parameter P005. All settings must only be entered by qualified personnel, paying particular attention to the safety precautions and warnings.

The parameter settings required can be entered using the three parameterisation buttons (P, Δ and ∇) on the front panel of the inverter (Figure 5 contains a flowchart for the procedure for setting parameter values). The parameter numbers and values are indicated on the four digit LED display.

	RUN Button	Press to start the inverter. The operation of this button can be selectively disabled by setting P121 = 0.
	STOP Button	Press to stop the inverter.
	Parameterisation Button	Press to toggle between parameter number and parameter value.
	UP Button	Press to set parameter numbers and parameter values to <i>higher</i> values. The operation of this button can be selectively disabled by setting P124 = 0.
	DOWN Button	Press to set parameter numbers and parameter values to <i>lower</i> values. The operation of this button can be selectively disabled by setting P124 = 0.
	JOG Button	Pressing this button while the inverter is stopped causes it to start and run at the preset frequency. The inverter stops as soon as the button is released. Pressing this button while the inverter is running has no effect. The operation of this button can be selectively disabled by setting P123 = 0.
	FORWARD/REVERSE Button	Press to change the direction of rotation of the motor. If REVERSE is selected, the LED display will indicate this by prefixing a minus sign (-) to the value displayed up to 99.9, or will display a flashing decimal point after the left-hand digit for values of 100.0 or greater.

e.g. 60.0 Hz in reverse mode =

120.0 Hz in reverse mode =

The operation of this button can be selectively disabled by setting P122 = 0.

4-digit LED display

Displays parameter number (P000 - P971), parameter value (000.0 - 999.9) or fault code (F001 - F188).

Note: Although the LED display only displays frequency values to a resolution of 0.1 Hz, you can increase the resolution to 0.01 Hz (see Note [6] in Figure 5 for the procedure).

IMPORTANT: Parameters above P009 cannot be adjusted unless P009 is first set to 002 or 003.

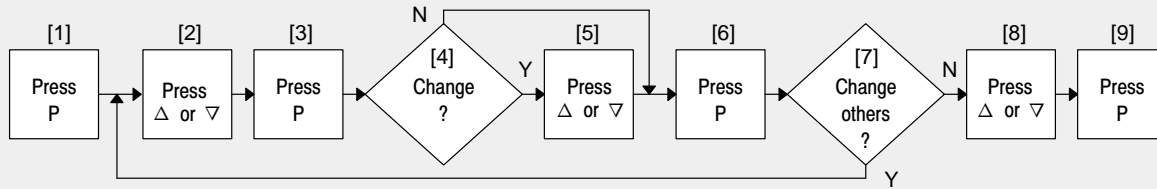

Notes

- [1] Display changes to 'P000'.
- [2] Select the parameter to change.
- [3] View the value of the parameter currently selected.
- [4] Do you wish to change the value? If not, go to [6].
- [5] Increase (Δ) or decrease (∇) the value of the parameter.
- [6] 'Lock' the new value into memory (if changed) and return to the parameter display.
- Note**
To increase the resolution to 0.01 when changing frequency parameters, instead of pressing P momentarily to return to the parameter display, keep the button pressed until the display changes to '-.n0' (n = the current tenths value, e.g. if the parameter value = '055.8' then n = 8). Press Δ or ∇ to change the value and then press P twice to return to the parameter display.
- [7] Do other parameters need changing? If so, return to [2].
- [8] Scroll up or down until 'P971' or 'P000' is displayed. If you scroll upwards, the display stops automatically at P971. However, pressing the Δ button again causes the display to 'wrap around' to P000.
- [9] Exit from the procedure and return to the normal operating display.

If parameters are changed accidentally, all parameters can be reset to their default values by setting parameter **P944** to **001** and then pressing **P**.

Fig. 5: Procedure for Changing Parameter Values

OPERATING INFORMATION

General

The inverter does not have a main power switch and is therefore live when the mains supply is connected. It waits with the output disabled for the RUN button to be pressed, or an ON signal via terminal 5 or 6 (rotate right or left), or a RUN command from the serial link.

If output frequency (P001 = 0) is selected as the display, the corresponding setpoint is displayed approximately every 1.5 seconds while the inverter is stopped.

The inverter is programmed at the factory for standard applications on Siemens four-pole standard motors. When using other motors it is necessary to enter the specifications from the motor's rating plate into parameters P081 to P085. Note that access to these parameters is not possible unless P009 has been set to 002 or 003.

When delivered, the inverter's frequency setpoint is set to 0.00 Hz, which means that the motor will not rotate! To make it start up, a setpoint must be entered using the Δ button or entering a value in P005 or setting a setpoint via the analogue or serial interfaces.

When a parameter value has been set, it is stored automatically in the internal memory.

Basic Operation

The most basic method of setting up the inverter for use is described below. This method uses a digital frequency setpoint and requires only the minimum number of parameters to be changed from their default settings.

- (1) Apply mains power to the inverter. Set parameter P009 to 002 or 003 to enable all parameters to be adjusted (see Figure 5 for the procedure).

- (2) Set parameter P005 to the desired frequency setpoint.

- (3) Press the RUN button (I) on the inverter's front panel. The inverter will now drive the motor at the frequency set by P005.

If required, the motor's speed (i.e. frequency) can be varied directly by using the Δ ∇ buttons. (Set P011 to 001 to enable the new frequency setting to be retained in memory during periods when the inverter is not running.)

Operation – Digital Control

- (1) Connect control terminal 5 to terminal 1 via a simple on/off switch. This sets up the inverter for clockwise rotation (default).
- (2) Apply mains power to the inverter. Check that parameter P006 is set to 000 to specify digital setpoint.
- (3) Set parameter P007 to 000 to specify digital input and disable the front panel controls.
- (4) Set parameter P005 to the desired frequency setpoint.
- (5) Set P011 to 001 to enable the new frequency setting to be retained in memory during periods when the inverter is not running.
- (6) Set the external on/off switch to ON. The inverter will now drive the motor at the frequency set by P005.

Operation – Analogue Control

- (1) Connect control terminal 5 to terminal 1 via a simple on/off switch. This sets up the inverter for clockwise rotation (default).
- (2) Connect a 10 kΩ potentiometer to the control terminals as shown in Figure 4 or connect a 0 – 10 V signal from pin 2 (0V) to pin 3.
- (3) Apply mains power to the inverter.
- (4) Set parameter P006 to 001 to specify analogue setpoint.
- (5) Set parameter P007 to 000 to specify digital input and disable the front panel controls.

- (6) Set parameters P021 and P022 to specify the minimum and maximum output frequency settings.
- (7) Set the external on/off switch to ON. Turn the potentiometer (or adjust the analogue control voltage) until the desired frequency is displayed on the inverter.

Stopping the Motor

Stopping can be achieved in several ways:

- Going down to 0.0 Hz (lowering the setpoint to 0.0 with the ∇ button causes the motor to come to a controlled stop in accordance with the selected ramp down rate (P003)).
- Cancelling the ON command, pressing the OFF button (O) on the front panel or setting the external on/off switch to OFF causes the inverter to ramp down at the selected ramp down rate (see P003).
- DC injection braking up to 250% causes an abrupt stop after cancellation of the ON command (braking is controlled via P073).
- Compound braking (braking is controlled via P066).

If the Motor Does Not Start Up

If the motor does not start up when the ON command has been given, check that the ON command is valid, check if a frequency setpoint has been entered in P005 and check that the motor specifications have been entered correctly.

If the inverter is configured for operation via the front panel (P007 = 001) and the motor does not start when the RUN button is pressed, check that P121 = 001 (RUN button enabled).

If the motor does not run after parameters have been changed accidentally, reset the inverter to the factory default parameter values by setting parameter **P944** to **001** and then pressing **P**.

Remote Control

The inverter can be controlled remotely via a USS data line connected to the serial interface terminals. If full remote control is required, parameter P910 must be set to 1.

Up to 31 inverters can be connected to an external control unit. Each inverter can be addressed individually by allocating a slave address (P091) to it.

EUROPEAN LOW VOLTAGE & EMC DIRECTIVES

European Low Voltage Directive



The MICRO MASTER Junior product complies with the requirements of the Low Voltage Directive 73/23/EEC.

The units are certified for compliance with the following standards:

- EN 60204-1 Safety of machinery – Electrical equipment of machines
- EN 60146-1-1 Semiconductor converters – General requirements and line commutated converters

European Machinery Directive

The MICRO MASTER Junior inverter series does not fall under the scope of the Machinery Directive. However, the products have been fully evaluated for compliance with the essential Health & Safety requirements of the directive when used in a typical machine application. A Declaration of Incorporation is available on request.

European EMC Directive

When installed according to the recommendations described in the operator's handbook, the MICRO MASTER Junior fulfils all requirements of the EMC Directive as defined by the EMC Product Standard for Power Drive Systems IEC 22G-WG4 (CV) 21.

ELECTRICAL DATA

Model	MMJ12	MMJ25	MMJ37	MMJ55	MMJ75	MMJ110	MMJ150
Order no.: 1 AC 230 V, Class A filter 1/3 AC 230 V, without filter 3 AC 380 – 460 V, without filter	6SE9110-7BA53 6SE9110-7CA13	6SE9111-5BA53 6SE9111-5CA13	6SE9112-0BA53 6SE9112-0CA13 6SE9111-1JA13	6SE9112-6BA53 6SE9112-6CA13 6SE9111-4JA13	6SE9113-4BA53 6SE9113-4CA13 6SE9113-4JA13	- - 6SE9112-7JA13	- - 6SE9113-7JA13
Motor output rating	120 W	250 W	370 W	550 W	750 W	1.1 kW	1.5 kW
Input voltage	230 V +/-15%		230 V +/-15% or 400 – 460 V +/-10%			400 – 460 V +/-10%	
Input frequency	47 – 63 Hz						
Output frequency range	0 – 200 Hz						
Max. continuous output	450 VA	660 VA	880 VA	1.14 kVA	1.5 kVA	2.1 kVA	2.8 kVA
Current: Output (nominal) Output (max. continuous) Input (max.)	0.76 A 0.85 A 1.5 A	1.5 A 1.6 A 3.0 A	2.0 A 2.3 A 3.8 A	2.6 A 3.3 A 5.5 A	3.4 A 3.9 A 6.5 A	2.0 A 2.2 A 3.0 A	2.8 A 3.0 A 4.1 A
Operating temperature	0°C to 40°C						
Mains fuse	10 A				16 A	10 A	
Min. lead cross-section: Input Output	1.0 mm ² 1.0 mm ²			1.5 mm ² 1.0 mm ²		1.0 mm ² 1.0 mm ²	
Max. lead cross-section: Control	1.5 mm ² single core / 1.0 mm ² multi-core						

OPTIONS / ACCESSORIES

DIN Rail Adapter Kit	6SE9190-0XX87-8DN0	NEMA1 Accessory Kit	6SE9190-0XX87-8NA0	PROFIBUS Module (OPmP)	6SE3190-0XX87-8PB0
Enhanced Operator Panel (OPm)	6SE3190-0XX87-8BF0	OPm/OPmP Interface Cable	6SE9190-0XX87-8SK0		

FAULT CODES

Code	Cause	Corrective Action
F001	Overvoltage in the DC link	(1) Check whether supply voltage is within the limits indicated on the rating plate. (2) Increase the ramp down time (P003). (3) Check whether the required braking power is within the specified limits.
F002	Overcurrent in the motor	(1) Check whether the motor power corresponds to the inverter power. (2) Check that the cable length limits have not been exceeded. (3) Check motor lead and motor for short-circuits and earth faults. (4) Check whether the motor parameters (P081 – P086) correspond with the motor being used. (5) Increase the ramp-up time (P002). (6) Reduce the boost set in P078 and P079. (7) Check whether the motor is obstructed or overloaded.
F003	Overload on the motor	(1) Check whether the motor is overloaded. (2) Increase the maximum motor frequency if a motor with high slip is used.
F005	Overtemperature in the inverter	(1) Check that the ambient temperature is not too high. (2) Check that the air inlet and outlet are not obstructed.
F008	Message timeout on the serial interface	(1) Check the serial interface. (2) Check the settings of the bus master and P091 – P093. (3) Check whether the timeout interval is too short (P093).
F009	Undervoltage in the DC link	Check the supply voltage.
F010	Initialisation fault	Check the entire parameter set. Set P009 to '0000' before power down.
F011	Internal interface fault	Switch off power and switch on again.
F012	Externally-activated trip	-
F013	Internal program fault	Switch off power and switch on again.
F074	Overtemperature in the motor	Check whether the motor is overloaded.
F106	P006 set incorrectly	Parameterise fixed frequency(ies) and/or motor potentiometer on the digital inputs.
F112	Value of P012 > value of P013	Set parameter P012 < P013.
F151-F153	P051 – P053 set incorrectly	Change the settings of digital inputs P051 to P053.
F188	Boost voltage calibration failure	(1) Motor not connected to inverter – connect motor. (2) See P088.

SYSTEM PARAMETERS



• = Parameter can be changed during operation.

☆☆☆ = Value depends on the rating of the motor.

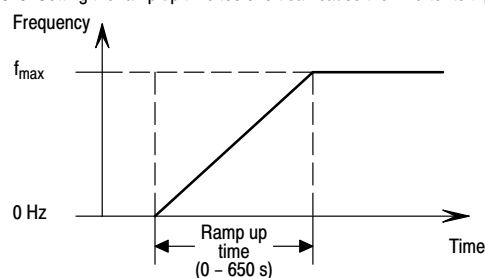
Parameter	Function	Range [Default]	Description / Notes
P000	Operating display	-	This displays the output selected in P001. In the event of a failure, the relevant error message (Fnnn) is displayed. In the event of a warning the display flashes. If output frequency has been selected (P001 = 0), the display alternates between the selected frequency and the actual frequency.
P001 •	Display selection	0 – 7 [0]	Display selection: 0 = Output frequency (Hz) 1 = Frequency setpoint (i.e. speed at which inverter is set to run) (Hz) 2 = Motor current (A) 3 = DC-link voltage (V) 4 = Not used 5 = Motor RPM 6 = USS status 7 = Not used
P002 •	Ramp up time (seconds)	0 – 650.00 [10.00]	This is the time taken for the motor to accelerate from standstill to the maximum frequency as set in P013. Setting the ramp up time too short can cause the inverter to trip (fault code F002 – overcurrent).

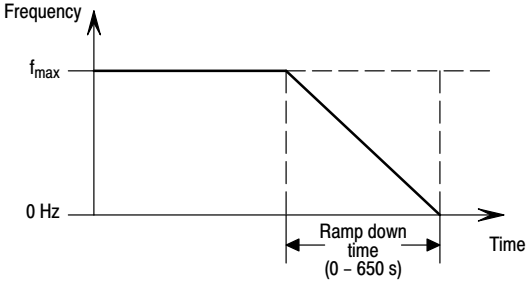
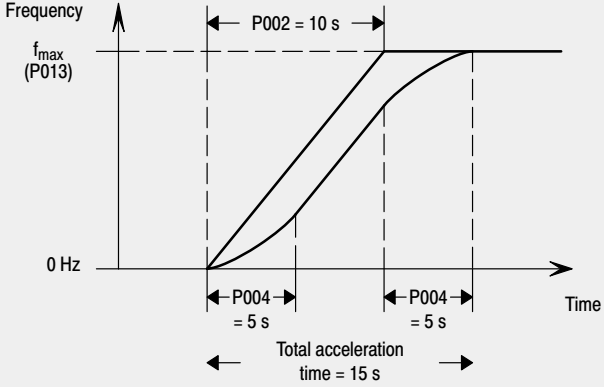

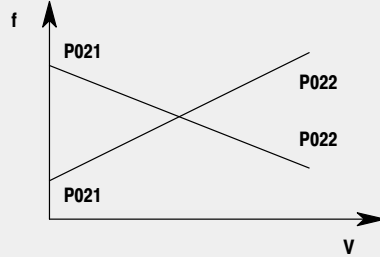
Parameter	Function	Range [Default]	Description / Notes
P003 •	Ramp down time (seconds)	0 – 650.00 [10.00]	This is the time taken for the motor to decelerate from maximum frequency (P013) to standstill. Setting the ramp down time too short can cause the inverter to trip (fault code F001 – overvoltage). 
P004 •	Smoothing (seconds)	0 – 40.00 [0.00]	Used to smooth the acceleration/deceleration of the motor (useful in applications where it is important to avoid 'jerking', e.g. conveyor systems, textiles, etc.). Smoothing is only effective if the ramp up/down time exceeds 0.3 s.  <p>Note: The smoothing curve for deceleration is based on the ramp up gradient (P002) and is added to the ramp down time set by P003.</p>
P005 •	Digital frequency setpoint (Hz)	0 – 200.00 [0.00]	Sets the frequency that the inverter will run at when operated in digital mode. Only effective if P006 set to '0'.
P006	Frequency setpoint type selection	0 – 2 [0]	Sets the control mode of the inverter: <ul style="list-style-type: none"> 0 = Digital. The inverter runs at the frequency set in P005 and can be adjusted using the Δ and ∇ buttons. Alternatively, if P007 is set to zero, the frequency may be controlled by setting any two of binary inputs P051 – P053 to values of 11 and 12. 1 = Analogue. Control via analogue input signal. 2 = Fixed frequency or motor potentiometer. Fixed frequency is only selected if the value of at least one binary input (P051 – P053) = 6, 17 or 18. Also, the Δ and ∇ buttons can be used to change the fixed frequency setpoint (as with P006 = 0), but note that the new setpoint selected in this manner is <u>not</u> retained in memory when P011 is set to 1. <p>Note: If P006 = 1 and the inverter is set up for remote control operation, the analogue inputs remain active.</p>
P007	Enable/disable front panel buttons	0 – 1 [1]	<ul style="list-style-type: none"> 0 = RUN, JOG and REVERSE are disabled. Control is via digital inputs (see parameters P051 – P053). Δ and ∇ may still be used to control frequency provided that P124 = 1 and a digital input has not been selected to perform this function. 1 = Front panel buttons can be selectively enabled or disabled depending on the setting of parameters P121 – P124.
P009 •	Parameter protection setting	0 – 3 [0]	Determines which parameters can be adjusted: <ul style="list-style-type: none"> 0 = Only parameters from P001 to P009 can be read/set. 1 = Parameters from P001 to P009 can be set and all other parameters can only be read. 2 = All parameters can be read/set but P009 automatically resets to 0 when power is removed. 3 = All parameters can be read/set.
P011	Frequency setpoint memory	0 – 1 [0]	<ul style="list-style-type: none"> 0 = Disabled 1 = Enabled after switch-off. i.e. The setpoint alterations made with the Δ / ∇ buttons are stored even when power has been removed from the inverter.
P012 •	Minimum motor frequency (Hz)	0 – 200.00 [0.00]	Sets the minimum motor frequency (must be less than the value of P013).
P013 •	Maximum motor frequency (Hz)	0 – 200.00 [50.00]	Sets the maximum motor frequency.
P014 •	Skip frequency 1 (Hz)	0 – 200.00 [0.00]	A skip frequency can be set with this parameter to avoid the effects of resonance of the inverter. Frequencies within ± 2 Hz of this setting are suppressed. Stationary operation is not possible within the suppressed frequency range – the range is just passed through.
P015 •	Automatic restart	0 – 1 [0]	Setting this parameter to '1' enables the inverter to restart automatically after a mains break or 'brownout', provided the run/stop switch is still closed. <ul style="list-style-type: none"> 0 = Disabled 1 = Automatic restart

Parameter	Function	Range [Default]	Description / Notes
P016 •	Start on the fly	0 – 4 [0]	Allows the inverter to start onto a spinning motor. Under normal circumstances the inverter runs the motor up from 0 Hz. However, if the motor is still spinning or is being driven by the load, it will undergo braking before running back up to the setpoint – this can cause an overcurrent trip. By using a flying restart, the inverter 'homes in' on the motor's speed and runs it up from that speed to the setpoint. 0 = Normal restart 1 = Flying restart after power up, fault or OFF2 (if P018 = 1). 2 = Flying restart every time (useful in circumstances where the motor can be driven by the load). 3 = As P016 = 1. 4 = As P016 = 2. Note: Also see P020.
P017 •	Smoothing type	1 – 2 [1]	1 = Continuous smoothing (as defined by P004). 2 = Discontinuous smoothing. This provides a fast unsmoothed response to STOP commands. Note: P004 must be set to a value > 0.0 for this parameter to have any effect.
P018 •	Automatic restart after fault	0 – 1 [0]	Automatic restart after fault: 0 = Disabled 1 = The inverter will attempt to restart up to 5 times after a fault. If the fault is not cleared after the 5th attempt, the inverter will remain in the fault state.
P020 •	Flying start ramp time (seconds)	0.50 – 25.00 [5.00]	Used in conjunction with P016. (Set longer times if persistent F002 trips occur.)
P021 •	Minimum analogue frequency (Hz)	0 – 200.00 [0.00]	Frequency corresponding to the lowest analogue input value, i.e. 0 V or 2 V, determined by P023. This can be set to a higher value than P022 to give an inverse relationship between analogue input and frequency output (see diagram in P022).
P022 •	Maximum analogue frequency (Hz)	0 – 200.00 [50.00]	Frequency corresponding to the highest analogue input value, i.e. 10 V, determined by P023. This can be set to a lower value than P021 to give an inverse relationship between analogue input and frequency output. i.e. 
P023 •	Analogue input function	0 – 2 [0]	0 = 0 V to 10 V 1 = 2 V to 10 V 2 = 2 V * to 10 V * The inverter will come to a controlled stop if V < 1 V. Note: Setting P023 = 2 will not work unless the inverter is under full local control (i.e. P910 = 0 or 4).
<div style="border: 1px solid black; padding: 5px; display: inline-block;">  <p>WARNING Setting P023 = 2 with no connections between control terminals 3 and 4 will cause the inverter to run immediately.</p> </div>			
P024 •	Analogue setpoint addition	0 – 2 [0]	If the inverter is not in analogue mode (P006 = 0 or 2), setting this parameter to '1' causes the analogue input value to be added. 0 = No addition 1 = Addition of the analogue setpoint to the fixed frequency or the motor potentiometer frequency. 2 = Scaling of digital/fixed setpoint by analogue input in the range 0 – 100%. Note: By selecting a combination of reversed negative fixed frequency settings and analogue setpoint addition, it is possible to configure the inverter for 'centre zero' operation with a +/-5 V supply or a 0 – 10 V potentiometer so that the output frequency can be 0 Hz at any position, including the centre position.
P027 •	Skip frequency 2 (Hz)	0 – 200.00 [0.00]	See P014.
P028 •	Skip frequency 3 (Hz)	0 – 200.00 [0.00]	See P014.
P029 •	Skip frequency 4 (Hz)	0 – 200.00 [0.00]	See P014.
P031 •	Jog frequency right (Hz)	0 – 200.00 [5.00]	Jogging is used to advance the motor by small amounts. It is controlled via the JOG button or with a non-latching switch on one of the digital inputs (P051 to P053). If jog right is enabled (DINn = 7), this parameter controls the frequency at which the inverter will run when the switch is closed. Unlike other setpoints, it can be set lower than the minimum frequency.
P032 •	Jog frequency left (Hz)	0 – 200.00 [5.00]	If jog left is enabled (DINn = 8), this parameter controls the frequency at which the inverter will run when the switch is closed. Unlike other setpoints, it can be set lower than the minimum frequency.
P041 •	1st fixed frequency (Hz)	0 – 200.00 [5.00]	Valid if (a) P006 = 2 and P051 = 6 or 18. or (b) P006 = 2 and P051 = P052 = 17.
P042 •	2nd fixed frequency (Hz)	0 – 200.00 [10.00]	Valid if (a) P006 = 2 and P051 = 6 or 18. or (b) P006 = 2 and P051 = P052 = 17.

Parameter	Function	Range [Default]	Description / Notes
-----------	----------	--------------------	---------------------

P043 • 3rd fixed frequency (Hz) 0 – 200.00 [20.00] Valid if (a) P006 = 2 and P051 = P052 = 17.
or (b) P006 = 2 and P053 = 6 or 18.

P045 Inversion fixed setpoints for fixed frequencies 1 – 3 0 – 7 [0] Sets the direction of rotation for the fixed frequency:

	FF 1	FF 2	FF 3
P045 = 0	⇒	⇒	⇒
P045 = 1	⇐	⇒	⇒
P045 = 2	⇒	⇐	⇒
P045 = 3	⇒	⇒	⇐
P045 = 4	⇒	⇒	⇒
P045 = 5	⇐	⇐	⇒
P045 = 6	⇐	⇐	⇐
P045 = 7	⇐	⇐	⇐

⇒ Fixed setpoints not inverted
⇐ Fixed setpoints inverted

P051 Selection control function, DIN1 (terminal 5), fixed frequency 1 or binary fixed frequency bit 1. 0 – 19 [1]

P052 Selection control function, DIN2 (terminal 6), fixed frequency 2 or binary fixed frequency bit 0. 0 – 19 [2]

P053 Selection control function, DIN3 (terminal 7), fixed frequency 3. 0 – 19 [6]

Value	Function of P051 to P053	Function, low state	Function, high state
0	Input disabled	-	-
1	ON right	Off	On right
2	ON left	Off	On left
3	Reverse	Normal	Reverse
4	OFF2	OFF2	On
5	OFF3	OFF3	On
6	Fixed frequencies 1 – 3	Off	On
7	Jog right	Off	Jog right
8	Jog left	Off	Jog left
9	Remote operation	Local	Remote
10	Fault code reset	Off	Reset on rising edge
11	Increase frequency *	Off	Increase
12	Decrease frequency *	Off	Decrease
13	Disable analogue input (setpoint is 0.0 Hz)	Analogue on	Analogue disabled
14	Disable 'P' button	'P' enabled	'P' disabled
15	Enable dc brake	Off	Brake on
16	<i>Do not use</i>	-	-
17	Binary fixed frequency control (fixed frequencies 1 – 3, see table below)	Off	On
18	As 6, but input high will also request RUN when P007 = 0.	Off	On
19	External trip / PTC input	Yes (F012)	No

* Only effective when P007 = 0.

Binary Fixed Frequency Map

	DIN1 (P051)	DIN2 (P052)
STOP	0	0
RUN to FF1 (P041)	0	1
RUN to FF2 (P042)	1	0
RUN to FF3 (P043)	1	1

P056 Digital input debounce time 0 – 2 [0] 0 = 12.5 ms
1 = 7.5 ms
2 = 2.5 ms

Parameter	Function	Range [Default]	Description / Notes
-----------	----------	--------------------	---------------------

P061 Selection relay output 0 – 13
[6]

Value	Relay function	Active
0	No function assigned (relay not active)	Low
1	Inverter is running	High
2	Inverter frequency 0.0 Hz	Low
3	Motor running direction right	High
4	External brake on (see parameters P063/P064)	Low
5	Inverter frequency less than or equal to minimum frequency	Low
6	Fault indication	Low
7	Inverter frequency greater than or equal to setpoint	High
8	Warning active (see P931 for type)	Low
9	Not used	-
10	Motor current limit (warning)	Low
11	Motor over temperature (warning)	Low
12, 13	Not used	-

Note: 'Active low' = relay OFF. 'Active high' = relay ON.

P062 Combination stop mode 0 – 4
[0]

This operates in the same manner as P061 = 4, except that a relay output is not provided. It allows a specified period of DC injection after stopping the motor to ensure that the motor shaft is locked (see P064).

0 = Normal stop mode
1 = Do not use
2 = Do not use
3 = Do not use
4 = Combination stop mode

P063 External brake release delay (seconds) 0 – 20.00
[1.00]

Only effective if the relay output is set to control an external brake (P061/P062 = 4). In this case when the inverter is switched on, it will run at the minimum frequency for the time set by this parameter before releasing the brake control relay and ramping up (see illustration in P064).

P064 External brake stopping time (seconds) 0 – 20.00
[1.00]

As P063, only effective if the relay output is set to control an external brake or if P062 = 4. This defines the period for which the inverter continues to run at the minimum frequency after ramping down and while the external brake is applied.

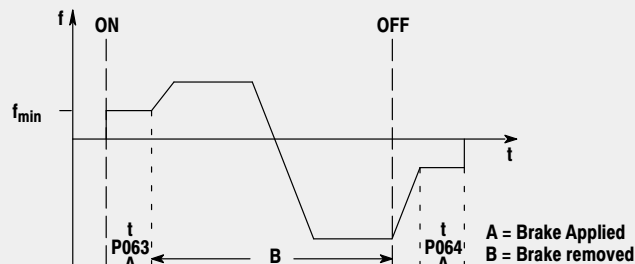

- Notes:**
- (1) Settings for P063 and P064 should be slightly longer than the actual time taken for the external brake to apply and release respectively.
 - (2) Setting P063 or P064 to too high a value, especially with P012 set to a high value, can cause an overcurrent warning or trip as the inverter attempts to move a locked motor shaft.

P066 Compound braking 0 – 1
[1]

0 = Off
1 = On. Permits faster ramp-down times and enhances stopping capability.

P073 • DC injection braking (%) 0 – 250
[0]

This stops the motor by applying a DC current. This causes heat to be generated in the motor rather than the inverter and holds the shaft stationary until the end of the braking period. Braking is effective for the period of time set by P003.

This function is disabled if P061/P062 = 4 (brake relay). The DC brake can be activated using DIN1 – DIN3 (see P051 – P053).

WARNING: Frequent use of long periods of dc injection braking can cause the motor to overheat.

P074 I^2t motor protection 0 – 1
[1]

0 = Disabled
1 = Enabled. Causes an F074 trip if the motor temperature exceeds the I^2t calculation.

P076 • Pulse frequency 0 – 10
[0 or 4]

Sets the pulse frequency (from 2 to 16 kHz) and the PWM mode. If silent operation is not absolutely necessary, the losses in the inverter as well as the RFI emissions can be reduced by selecting lower pulse frequencies.

- 0/1 = 16 kHz (230 V default)
- 2/3 = 8 kHz
- 4/5 = 4 kHz (400 V default)
- 6/7 = 2 kHz
- 8 = 16 kHz
- 9 = 8 kHz
- 10 = 4 kHz

Parameter	Function	Range [Default]	Description / Notes
P077	Voltage/frequency curve selection	0 – 2 [0]	Controls the relationship between the speed of the motor and the voltage supplied by the inverter. One of three modes can be selected: 0 or 1 = Linear voltage/frequency Use this curve for synchronous motors or motors connected in parallel. 2 = Quadratic voltage/frequency relationship This is suitable for pumps and fans.
P078 •	Continuous boost (%)	0 – 250 [100]	Operates continuously over the whole frequency range. For many applications it is necessary to increase low frequency torque. This parameter sets the start-up boost voltage at 0 Hz to adjust the available torque for low frequency operation. Range 0 – 250% of the motor current rating. WARNING: If P078 is set too high, overheating of the motor can occur.
P079 •	Starting boost (%)	0 – 250 [0]	For drives which require a high initial starting torque, it is possible to set an extra voltage increase by boosting the starting current by 0 – 250% of the nominal motor current. This increase is only effective during initial start up and until the frequency setpoint is reached. Note: This increase is in addition to P078.
P081	Nominal frequency for motor (Hz)	0 – 200.00 [50.00]	These parameters must be set for the motor used. Read the specifications on the motor's rating plate. Note: The inverter's default settings vary according to the power rating.
P082	Nominal speed for motor (RPM)	0 – 9999 [☆☆☆]	
P083	Nominal current for motor (A)	0.1 – 99.9 [☆☆☆]	
P084	Nominal voltage for motor (V)	0 – 1000 [☆☆☆]	
P085	Nominal power for motor (kW)	0 – 50.00 [☆☆☆]	
P088	Automatic calibration	0 – 1 [0]	The stator resistance is used in the inverter's current monitoring calculations. This function allows the inverter to perform an automatic measurement of stator resistance, stores it in P089 and then resets P088 to '0'. If the measured resistance is too high for the size of inverter (e.g. motor not connected or unusually small motor connected), the inverter will trip (fault code F188) and will leave P088 set to '1'. If this happens, set P089 manually and then set P088 to '0'.
P089 •	Stator resistance (Ω)	0.01 – 200.00 [☆☆☆]	Can be used instead of P088 to set the stator resistance manually. The value entered should be the resistance between any two phases. Note: If the value of P089 is too high then an overcurrent trip (F002) may occur.
P091 •	Slave address	0 – 30 [0]	Up to 31 inverters can be connected via the serial link and controlled by a computer or PLC using the USS protocol. This parameter sets a unique address for the inverter.
P092 •	Baud rate	3 – 7 [6]	Sets the baud rate of the RS485 serial interface (USS protocol): 3 = 1200 baud 4 = Do not use 5 = 4800 baud 6 = 9600 baud 7 = 19200 baud Note: Some RS232 to RS485 converters are not capable of baud rates higher than 4800.
P093 •	Timeout (seconds)	0 – 240 [0]	This is the maximum permissible period between two incoming data telegrams. In applications where the inverter is usually controlled or monitored constantly via the serial link, this feature is used to turn off the inverter in the event of a communications failure. Timing starts after a valid data telegram has been received and if a further data telegram is not received within the specified time period, the inverter will trip and display fault code F008. Setting the value to zero switches off the control.
P094 •	Serial link nominal system setpoint (Hz)	0 – 200.00 [50.00]	Setpoints are transmitted to the inverter via the serial link as percentages. The value entered in this parameter represents 100% (4000Hz).
P095 •	USS compatibility	0 – 2 [0]	0 = Compatible with 0.1 Hz resolution 1 = Enable 0.01 Hz resolution 2 = PZD is not scaled but represents the actual frequency value to a resolution of 0.01 Hz (e.g. 5000 = 50 Hz).
P101 •	Operation for Europe or USA	0 – 1 [0]	This sets the inverter for European or USA supply and motor frequency: 0 = Europe (50 Hz) 1 = USA (60 Hz)

Parameter	Function	Range [Default]	Description / Notes
P111	Inverter power rating (kW/hp)	0 – 50.00 [☆☆☆]	Read-only parameter that indicates the power rating of the inverter in kW. e.g. 0.55 = 550 W Note: If P101 = 1 then the rating is displayed in hp.
P121	Enable/disable RUN button	0 – 1 [1]	0 = RUN button disabled 1 = RUN button enabled (only possible if P007 = 1)
P122	Enable/disable FORWARD/REVERSE button	0 – 1 [1]	0 = FORWARD/REVERSE button disabled 1 = FORWARD/REVERSE button enabled (only possible if P007 = 1)
P123	Enable/disable JOG button	0 – 1 [1]	0 = JOG button disabled 1 = JOG button enabled (only possible if P007 = 1)
P124	Enable/disable Δ and ∇ buttons	0 – 1 [1]	0 = Δ and ∇ buttons disabled 1 = Δ and ∇ buttons enabled (only possible if P007 = 1) Note: This applies for frequency adjustment only.
P131	Frequency setpoint (Hz)	0 – 200.00 [-]	Read-only parameters. These are copies of the values stored in P001 but can be accessed directly via the serial link.
P132	Motor current (A)	0 – 99.9 [-]	
P134	DC link voltage (V)	0 – 1000 [-]	
P135	Motor RPM	0 – 9999 [-]	
P137	Motor voltage (V)	0 – 1000 [-]	
P910 •	Local/Remote mode	0 – 4 [0]	Sets the inverter for local control or remote control over the serial link: 0 = Local control 1 = Remote control (and setting of parameter values) 2 = Local control (but remote control of frequency) 3 = Remote control (but local control of frequency) 4 = Local control (but remote read and write access to parameters and facility to reset trips) Note: When operating the inverter via remote control (P910 = 1 or 3), the analogue input remains active when P006 = 1 and is added to the setpoint.
P922	Software version	0 – 9999 [-]	Contains the software version number and cannot be changed.
P923 •	Equipment system number	0 – 255 [0]	You can use this parameter to allocate a unique reference number to the inverter. It has no operational effect.
P930	Most recent fault code	0 – 9999 [-]	The last recorded fault code is stored in this parameter. It is cleared when the inverter is reset. Note: The warning may be cleared by attempting to change its value.
P931	Most recent warning type	0 – 9999 [-]	The last recorded warning is stored in this parameter until power is removed from the inverter: 002 = Current limit active 003 = Voltage limit active 004 = Slip limit exceeded 005 = Motor overtemperature Note: The warning may be cleared by attempting to change its value.
P944	Reset to factory default settings	0 – 1 [0]	Set to '1' and then press P to reset all parameters except P101 to the factory default settings.
P971 •	EEPROM storage control	0 – 1 [1]	0 = Changes to parameter settings are lost when power is removed. 1 = Changes to parameter settings are retained during periods when power is removed.