

efesotomasyon.com



cm-eib FOR LOGO!

Communication with LOGO!
with EIB and the Konnex standard

SIEMENS

SIEMENS

CM EIB/KNX

LOGO! Expansion Module

Manual

Chapters

- Safety Notices
- 1 Getting to know CM EIB
- 2 Mounting and wiring the CM EIB
- 3 Putting the CM EIB into operation
- 4 Supported functions
- 5 CM EIB specifications
- INDEX

Copyright - Siemens AG 1996 to 2002 All rights reserved

You may not transfer or duplicate this document or utilize or reveal its contents, unless expressly authorized in writing. In the case of a violation, you will be obliged to pay damages. All rights reserved, in particular in the event that a patent is granted or that a utility model is registered.

Disclaimer of liability:

We have checked that the contents of this document correctly describe the associated hardware and software. Nonetheless, it is impossible to exclude the possibility of deviations and therefore we cannot guarantee that there are no errors in this document. The information in this document is checked regularly and any necessary corrections are then made in the next release issued. We are of course thankful for any suggestions for improvements.

Table of Contents

Safety Notices

1	Getting to know CM EIB	5
1.1	What is the CM EIB?	5
1.2	The construction of the CM EIB	6
2	Mounting and wiring the CM EIB/KNX.....	7
2.1	General guidelines	7
2.2	Wiring the CM EIB	9
2.2.1	Connecting the power supply	10
2.2.2	Connecting the <i>EIB</i>	11
3	Putting the CM EIB into operation	12
3.1	Step-by-step.....	12
3.2	The CM EIB - operational status.....	13
3.3	Behavior in case of a fault.....	15
4	Supported functions.....	16
4.1	Inputs / Outputs.....	16
4.2	Available communication objects.....	18
4.3	<i>EIB</i> configuration.....	19
5	CM EIB - Specifications.....	22

Safety Notices



DANGER

Indicates that **death, severe bodily injury or substantial material damage** will occur, if the corresponding safety measures are not taken.



WARNING

Indicates that **death or severe bodily injury may occur**, if the corresponding safety measures are not taken.



CAUTION

With the warning triangle, this indicates that **minor bodily injury may occur**, if the corresponding safety measures are not taken.

CAUTION

Without the warning triangle, this indicates that **material damage may occur**, if the corresponding safety measures are not taken.

WARNING

This indicates that an **undesirable result or condition may occur**, if the corresponding instructions are not observed.

1 Getting to know CM EIB

1.1 What is the CM EIB?

This is the communications module (CM) for connecting the LOGO! to the EIB bus.

The LOGO! communications module has been implemented as a Slave module for the LOGO control module (12/24 or 115/240 Volt).

The module supports communication between the LOGO! Master and external EIB devices via an *EIB*.

The CM is a bus participant on the *EIB* and allows the LOGO! to communicate with other EIB devices using EIB telegrams.

What are the capabilities of the CM EIB?

The CM transfers EIB telegrams to the LOGO! and LOGO! functions to the *EIB*.

The CM presents the current states of the EIB devices to the LOGO!, which is thus able to use its logical functions and timers to join them together. In the process, the EIB signals can also be combined with the signals of the local LOGO! inputs and outputs. The CM then transmits every change of the output signal via the *EIB*.

The combination of LOGO! and CM EIB gives the user a decentralized controller functionality for the *EIB* with the capability of setting or changing parameters or operations quickly, simply and without a programming device.

1.2 The construction of the CM EIB

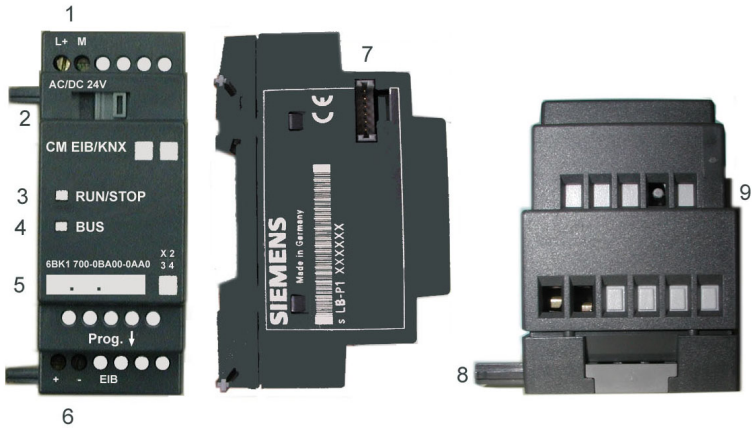

1. Power supply
2. Bus lock slide, interface to the LOGO!
3. The RUN/STOP LED for communication with LOGO!
4. The BUS LED, EIB communications
5. Label for the physical address
6. Inputs - EIB connection
7. Expansion interface to the LOGO!
8. Mechanical coding - pin
9. Programming button

2 Mounting and wiring the CM EIB/KNX

2.1 General guidelines

- The following guidelines must be observed when mounting and wiring your CM EIB:
- When wiring the CM EIB, make certain that you follow all of the applicable and legally binding standards. Observe all of the relevant national and regional regulations when installing and operating the device. Check with the local authorities regarding the standards and regulations that must be observed in your special case.
- Make certain that the device is de-energized.
- Use only approved bus cables.
- The EIB bus cables may also be laid parallel to other lines.
- The CM EIB must always be installed as the last module on the right of the LOGO!, since you may not install other expansion modules onto the CM EIB.

Please note:

- The CM EIB must have its own voltage supply (24V).
-

NOTE

This module may only be mounted and wired by qualified personnel, who know and observe the generally applicable guidelines and applicable regulations and standards.

Observe the assembly and disassembly instructions in the LOGO! manual.



WARNING

The expansion module may only inserted or removed when the power is off.

2.2 Wiring the CM EIB

To wire the CM EIB, use a screwdriver with a 3 mm wide blade.

There is no difference between the terminals of the LOGO! and the *EIB*.

NOTE

To protect personnel against unintentional contact with the portions of the CM EIB that are conducting electricity, the appropriate national and local standards must be observed. The CM EIB is a double-insulated switching device. A protective grounding conductor is not necessary.

2.2.1 Connecting the power supply

The CM EIB has been designed to serve as a Slave module for the LOGO! controller. It must be connected to a 24 V AC/DC supply voltage.

Please observe the relevant instructions that are found in product information that was included with your equipment as well as the technical data regarding the permissible voltage tolerances, mains frequency and current consumption.

Connecting

How to connect the CM EIB to the power:

CM EIB with
DC supply

CM EIB with
AC supply

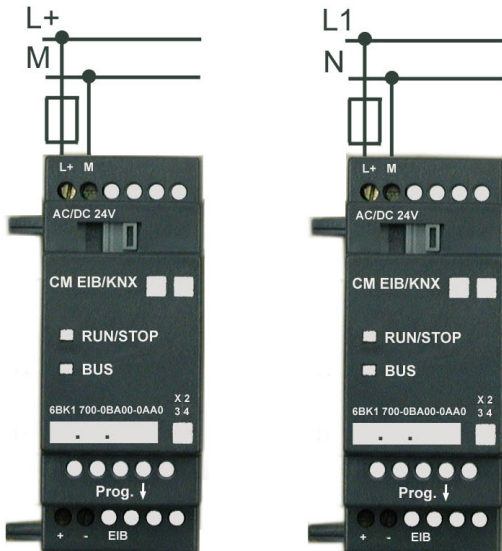

Protect with a
80 mA/slow action fuse, if desired (recommended).

2.2.2 Connecting the *EIB*

This connection is made using the two screw terminals (+ and -).

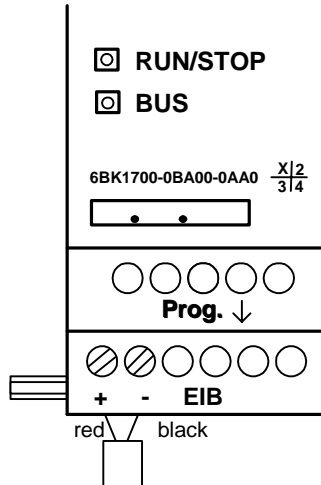

Only the red – black pair is used, the white – yellow pair is not connected.

You can set the CM EIB in the programming mode by pressing on the “Prog ↓” button.

NOTE

Don't apply too much force when pressing the “Prog ↓” button.
When contact has been made, the LED will light up in orange.

3 Putting the CM EIB into operation

3.1 Step-by-step

1. Both the BUS and supply voltage must be present.
2. Connect a PC to the serial EIB interface.
3. Start ETS. Use ETS2 Version 1.2.
4. Use ETS2, V.1.2 to configure the application program.
5. The application program is loaded into the devices via the EIB interface. The application program is available for downloading from the LOGO! homepage (<http://www.siemens.de/logo>).
6. In ETS, click on "Program Physical Address".
7. Press the button on the CM EIB to set the CM EIB in programming mode; the LED will light up in orange.
8. When the LED goes out, the physical address has been programmed. You can now note the physical address on the device.

The syntax of the physical address:

Area	/	Line	/	Device
XX	/	XX	/	XXX

9. The application program can now be loaded. Afterwards, the device is ready for operation.

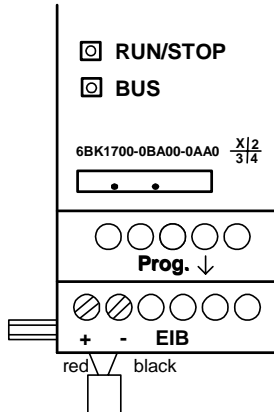

10. If multiple CM EIBs have been installed in an EIB system, repeat Steps 1 to 9 for each CM EIB.
11. For further details regarding the EIB installation, please read the corresponding documentation.

3.2 The CM EIB - operational status

The CM EIB is a LOGO! expansion module. This module has two LED displays:

- | | |
|-------------------|------------------------------|
| 1. "RUN/STOP" LED | Communication with the LOGO! |
| 2. "BUS" LED | EIB-Bus status |

The “**RUN/STOP**” LED will light in green, red or orange.

LED Lights In		
Green (RUN)	Red (STOP)	Orange
The expansion module is communicating with the device on the left.	The expansion module is not communicating with the device on the left.	The expansion module's initialization phase

The “**BUS**” LED will light in green, red or orange.

LED Lights In		
Green	Red	Orange
Bus connection OK, communication OK, not programming mode	Bus connection fault	Programming mode active and bus connection OK

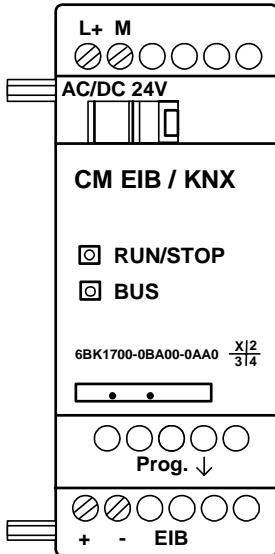

3.3 Behavior in case of a fault

LOGO! - Power failure

If the power to the LOGO! fails or the communications with the LOGO! Master or the communications partner to the left is interrupted, the outputs will be set to 0. The “RUN/STOP” LED will light in RED after one second.

LOGO! - Power returns

The LOGO! will startup and the CM will send the parameterized status.

CM - Power failure

All of the inputs of the *EIB's* LOGO! Master will be set by the LOGO! Master to 0.

CM - Power returns

All of the LOGO!Master outputs on the *EIB* will be updated. The inputs will be – depending on the *EIB* parameters – read.

BUS - Short-circuit or interruption

The inputs and outputs will retain their last value until they receive a new one. After 5 seconds, the Bus LED will light in red.

BUS - Restored

When the BUS is restored, the CM remains neutral, i.e. it does not send any telegrams.

4 Supported functions

The CM EIB supports the communications between the LOGO! and *EIB* and supplies the I/O necessary for the communication via the *EIB*.

4.1 Inputs / Outputs

The standard CM EIB application fills the complete LOGO! process image.

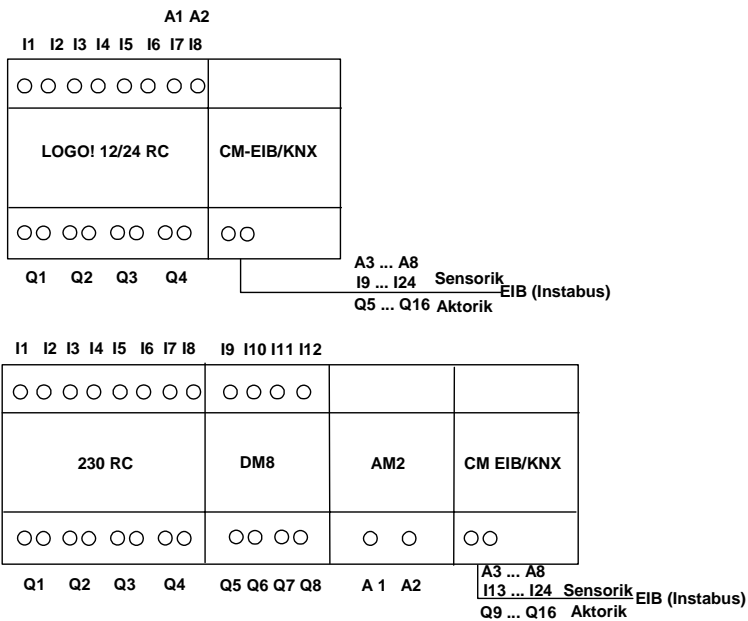

Sample application:

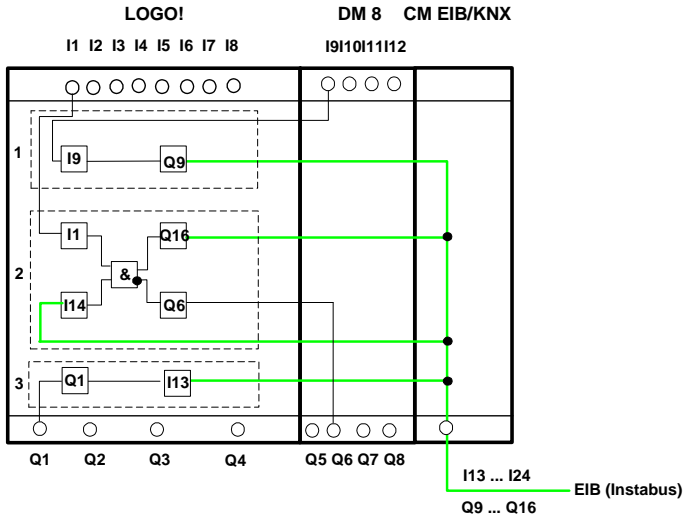

1. To map the LOGO! inputs (I1 to I8 and I9 to I12) as outputs on the *EIB*, these must be joined with free EIB outputs (Q9 to Q16) in the LOGO! application.
2. Operations (basic functions BF / special functions SF) useable within the LOGO! application (e.g. as a feedback signal).
3. To access the LOGO! application (Q1 to Q4 and Q5 to Q8) directly via the bus communications, these must be joined with free EIB inputs (I13 to I24) in the LOGO! application.

4.2 Available communication objects

An example of the basic variant – LOGO! CPU and CM EIB without an expansion module:

The following communication objects will be available on the EIB / KNX Bus:

EIB-Object No.	Type	(Size)	EIS	IN / OUT
0	UINT1	EIS1	I9	Input
1	UINT1	EIS1	I10	Input
2	UINT1	EIS1	I11	Input
3	UINT1	EIS1	I12	Input
4	UINT1	EIS1	I13	Input
5	UINT1	EIS1	I14	Input
6	UINT1	EIS1	I15	Input
7	UINT1	EIS1	I16	Input
8	UINT1	EIS1	I17	Input
9	UINT1	EIS1	I18	Input
10	UINT1	EIS1	I19	Input
11	UINT1	EIS1	I20	Input
12	UINT1	EIS1	I21	Input
13	UINT1	EIS1	I22	Input
14	UINT1	EIS1	I23	Input
15	UINT1	EIS1	I24	Input
16	UINT1	EIS1	Q5	Output
17	UINT1	EIS1	Q6	Output
18	UINT1	EIS1	Q7	Output
19	UINT1	EIS1	Q8	Output
20	UINT1	EIS1	Q9	Output
21	UINT1	EIS1	Q10	Output
22	UINT1	EIS1	Q11	Output
23	UINT1	EIS1	Q12	Output
24	UINT1	EIS1	Q13	Output
25	UINT1	EIS1	Q14	Output
26	UINT1	EIS1	Q15	Output
27	UINT1	EIS1	Q16	Output
28	UINT16 / UINT8	EIS5 / EIS6	A11	Input
29	UINT16 / UINT8	EIS5 / EIS6	A12	Input
30	UINT16 / UINT8	EIS5 / EIS6	A13	Input
31	UINT16 / UINT8	EIS5 / EIS6	A14	Input
32	UINT16 / UINT8	EIS5 / EIS6	A15	Input
33	UINT16 / UINT8	EIS5 / EIS6	A16	Input
34	UINT16 / UINT8	EIS5 / EIS6	A17	Input
35	UINT16 / UINT8	EIS5 / EIS6	A18	Input

EIS1 (switches) 1 Bit

EIS 5 (EIB floating) 2 byte value

EIS 6 (EIB floating) 1 byte value

4.3 EIB configuration

The following application parameters can be set in ETS2, V.1.2:

- The number of digital I/Os on the LOGO! Master or expansion modules
- The number of analog inputs on the LOGO! Master or expansion modules
- The data type for each analog input EIS6 (scaling/8-bit with sign) or EIS5 (EIB-Value Temp/8-bit without sign).

In the parameter dialog, you can set the number of inputs and outputs that are already on the LOGO! (including expansion modules) and how many are available via the *EIB*.



The EIS5 values are converted to a fixed point numerical value with a resolution of 0.1, which equates to a value range of -3276.8 (FFFFh) to $+3276.7$ (7FFFh).

EIS6 values for scaling are accepted, i.e. 0 to 100 % corresponds to an analog value of 0 to 255.

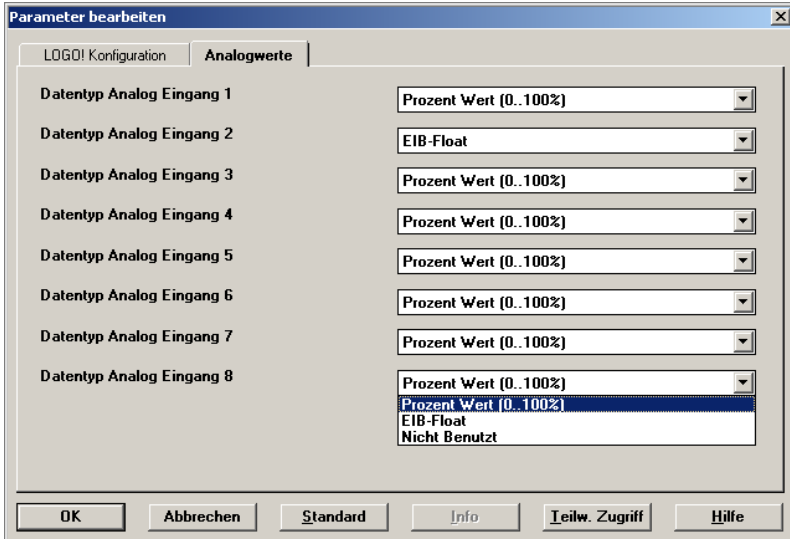

Unused analog inputs must be set to "Not Used".

Inputs/Outputs – Special Considerations

When using the LOGO! I/O on the CM EIB, you must consider the following.

To access the LOGO! outputs (Q1 to Q4) directly via communication over the bus, these must be joined in the LOGO! application with free EIB inputs.

To map the LOGO! inputs (I1 to I8) as outputs on the bus, these must be joined in the LOGO! application with free EIB outputs.

The outputs on additional I/O modules can also be transferred in parallel via the *EIB*.

5 CM EIB - Specifications

Electrical Data

Supply voltage	24 V AC	24 V DC
Permissible range	-15% +10%	-15% +20%
Current consumption (power supply)	max. 25 mA	
Current taken from BUS	5 mA	
EIB data transfer rate	9600 Baud	

Physical Construction

Standard width	2 SU
Dimensions (W x H x D)	36 x 90 x 55 mm
Weight	approx. 50 g
Mounting options	35 mm rail wall mounting
Operational status display	RUN/STOP LED - communications with LOGO! BUS LED – communications with EIB/KNX
Controls	EIB/KNX programming button S1

Connections

LOGO! connection	Standard expansion interface for LOGO! 12/24 V and 115/240 V
EIB connection (TP 256)	2 screw terminals (0.5 – 2.5 mm ²)
max. torque	0.5 Nm
Power supply	2 screw terminals (0.5 – 2.5 mm ²)
max. torque	0.5 Nm
Standard bus lines to use	YCYM or J-Y(ST)Y (2 x 2 x 0.8 mm ²)
Digital inputs (I) - virtual	max. 16
Digital outputs (Q) - virtual	max. 12
Analog inputs (AI) - virtual	max. 8
Max. group addresses	64
Max. associations	64

Environmental Conditions

Permissible operating temperature	0°C to +55°C free convection
Storage and transport temperatures	-40°C to +70°C
Humidity	95% at +25°C

Safety

Protection standard	IP 20
Radio interference suppression	EN 55011 (Limit Value Class B)
Certification	CE EIB/KNX UL 508 VDE 0631 IEC 61131-2
Overvoltage protection	
Fuse	80 mA slow action fuse

Order Data

LOGO! Expansion Module	
EIB/KNX CM	6BK1700-0BA00-0AA0

INDEX

<i>EIB</i>	European Installation Bus
EIS	EIB Interoperability Standard
ETS	EIB Tool Software
KNX	Standard of the Konnex Association

Siemens Aktiengesellschaft

Automation and Drives
Systems Engineering
PO. 2355, D-90713 Fürth

www.siemens.com

Order No. J31069-D1262-U002-A4-7618