

SIEMENS

efesotomasyon.com

SIMATIC

S7-300 CPU 31xT

Manual

Preface

Product Overview

1

Operator controls and
indicators

2

Setting up an S7-300 with a
Technology CPU

3

Communication with S7-300

4

Memory concept

5

Cycle and response times

6

Technical data

7

Appendix

A

03/2008

A5E01672599-01

Safety Guidelines

This manual contains notices you have to observe in order to ensure your personal safety, as well as to prevent damage to property. The notices referring to your personal safety are highlighted in the manual by a safety alert symbol, notices referring only to property damage have no safety alert symbol. These notices shown below are graded according to the degree of danger.

| |
|--|
| ⚠ DANGER |
| indicates that death or severe personal injury will result if proper precautions are not taken. |
| ⚠ WARNING |
| indicates that death or severe personal injury may result if proper precautions are not taken. |
| ⚠ CAUTION |
| with a safety alert symbol, indicates that minor personal injury can result if proper precautions are not taken. |
| CAUTION |
| without a safety alert symbol, indicates that property damage can result if proper precautions are not taken. |
| NOTICE |
| indicates that an unintended result or situation can occur if the corresponding information is not taken into account. |

If more than one degree of danger is present, the warning notice representing the highest degree of danger will be used. A notice warning of injury to persons with a safety alert symbol may also include a warning relating to property damage.

Qualified Personnel

The device/system may only be set up and used in conjunction with this documentation. Commissioning and operation of a device/system may only be performed by **qualified personnel**. Within the context of the safety notes in this documentation qualified persons are defined as persons who are authorized to commission, ground and label devices, systems and circuits in accordance with established safety practices and standards.

Prescribed Usage

Note the following:

| |
|--|
| ⚠ WARNING |
| This device may only be used for the applications described in the catalog or the technical description and only in connection with devices or components from other manufacturers which have been approved or recommended by Siemens. Correct, reliable operation of the product requires proper transport, storage, positioning and assembly as well as careful operation and maintenance. |

Trademarks

All names identified by ® are registered trademarks of the Siemens AG. The remaining trademarks in this publication may be trademarks whose use by third parties for their own purposes could violate the rights of the owner.

Disclaimer of Liability

We have reviewed the contents of this publication to ensure consistency with the hardware and software described. Since variance cannot be precluded entirely, we cannot guarantee full consistency. However, the information in this publication is reviewed regularly and any necessary corrections are included in subsequent editions.

Preface

Purpose of this manual

This manual contains all the essential information about:

- The configuration
- Communication
- The memory concept
- Cycle and response times
- CPU technical data.

Finally you will learn the points to consider when upgrading to one of the CPUs discussed in this manual.

Required basic knowledge

Knowledge required to understand this manual:

- General knowledge of automation
- Knowledge of motion control
- Knowledge of the STEP 7 basic software.

Required configuration tools

To configure the Technology CPU you require STEP 7, Version V5.4 SP2 or higher and the optional package S7 Technology, Version V4.1 or higher.

Scope of this manual

Table 1 Scope of this manual

| CPU | Order No. | As of Version firmware |
|---------------|---------------------|------------------------|
| CPU 315T-2 DP | 6ES7 315-6TH13-0AB0 | V2.6/V4.1.1 |
| CPU 317T-2 DP | 6ES7 317-6TK13-0AB0 | V2.6/V4.1.1 |

This manual describes

- The differences of the Technology CPU compared with the Operating Instructions S7-300 CPU 31xC and 31x: Installation
- The properties of the Technology CPU

Note

For new modules, or modules of a more recent version, we reserve the right to include Product Information containing latest information.

Changes since with the previous edition

The previous editions of this manual are the manuals S7-300 CPU data: CPU 315T-2 DP and S7-300 CPU data: CPU 317T-2 DP. These have been combined to form the current manual S7-300 CPU 31xT.

The following changes have been made since the previous editions:

- Isochronous mode on PROFIBUS DP
- Variable process image
- Extension of block-specific messages (SFC 105 - SFC -108)
- Time synchronization over DP
- Updating the firmware online (via networks)
- Reset of the CPU to delivery state
- Measuring proximity switch for diagnostic repeater, for DP CPUs (SFC 103)
- I&M of the CPU (e.g. higher-level and location IDs)

Standards and certificates

Refer to section General technical data > Standards and certificates.

Recycling and disposal

The devices described in this manual can be recycled, because their components contain a minimum of harmful substances

. For environment-friendly recycling and disposal of your old equipment, contact a certified disposal facility for electronic scrap.

Further support

Refer to the Product Information Technical Support, Contacts and Training for more information. You will find the product information on the Internet at:

<http://support.automation.siemens.com>, article ID 19293011

Table of contents

| | | |
|----------|--|-----------|
| | Preface | 3 |
| 1 | Product Overview | 9 |
| 2 | Operator controls and indicators | 13 |
| 3 | Setting up an S7-300 with a Technology CPU | 17 |
| 3.1 | Overview | 17 |
| 3.2 | S7-300 components | 17 |
| 3.3 | Configuring | 18 |
| 3.3.1 | Single-tier configuration | 18 |
| 3.3.2 | Subnets | 18 |
| 3.4 | Addressing | 19 |
| 3.5 | Commissioning | 20 |
| 3.6 | Operating system | 20 |
| 3.7 | Status and error displays | 21 |
| 4 | Communication with S7-300 | 25 |
| 4.1 | Interfaces | 25 |
| 4.1.1 | Overview | 25 |
| 4.1.2 | MPI/DP interface (X1) | 26 |
| 4.1.3 | PROFIBUS DP (DRIVE) interface (X3) | 29 |
| 4.1.4 | Information about interface X3 DP(DRIVE) | 30 |
| 4.2 | Communication services | 30 |
| 4.2.1 | Overview | 30 |
| 4.2.2 | PG communication | 31 |
| 4.2.3 | OP communication | 32 |
| 4.2.4 | S7 basic communication | 32 |
| 4.2.5 | S7 communication | 33 |
| 4.2.6 | Global data communication (MPI only) | 33 |
| 4.2.7 | Routing | 34 |
| 4.2.8 | Data consistency | 37 |
| 4.3 | S7 connections | 38 |
| 4.3.1 | S7 connection as communication path | 38 |
| 4.3.2 | Assignment of S7 connections | 39 |
| 4.3.3 | Distribution and availability of S7 connection resources | 40 |
| 4.4 | DPV1 | 42 |
| 4.4.1 | General information about DPV1 | 42 |

| | | |
|----------|--|-----------|
| 5 | Memory concept | 45 |
| 5.1 | Memory areas and retentive address areas | 45 |
| 5.1.1 | Technology CPU memory areas | 45 |
| 5.1.2 | Retentive address areas of the load memory, system memory and technology system data | 47 |
| 5.1.3 | Retentivity of memory objects | 48 |
| 5.1.4 | Address areas of system memory | 50 |
| 5.1.5 | Properties of the SIMATIC Micro Memory Card | 54 |
| 5.2 | Memory functions | 55 |
| 5.2.1 | General: Memory functions | 55 |
| 5.2.2 | Load user program from SIMATIC Micro Memory Card to the CPU | 56 |
| 5.2.3 | Handling blocks | 57 |
| 5.2.3.1 | Downloading new blocks or delta downloads | 57 |
| 5.2.3.2 | Uploading blocks | 57 |
| 5.2.3.3 | Deleting blocks | 57 |
| 5.2.3.4 | Compressing blocks | 58 |
| 5.2.3.5 | Promming (RAM to ROM) | 58 |
| 5.2.4 | CPU memory reset and restart | 58 |
| 5.2.5 | Backup of project data to SIMATIC Micro Memory Card | 59 |
| 5.3 | Recipes | 60 |
| 5.4 | Measured value log files | 61 |
| 5.5 | Technology data blocks | 63 |
| 5.6 | Memory of the integrated technology of the CPU | 64 |
| 6 | Cycle and response times | 67 |
| 6.1 | Overview | 67 |
| 6.2 | Cycle time | 68 |
| 6.2.1 | Overview | 68 |
| 6.2.2 | Calculating the cycle time | 70 |
| 6.2.3 | Different cycle times | 73 |
| 6.2.4 | Communication Load | 74 |
| 6.2.5 | Cycle time extension as a result of testing and commissioning functions | 76 |
| 6.3 | Response time | 77 |
| 6.3.1 | Overview | 77 |
| 6.3.2 | Shortest response time | 79 |
| 6.3.3 | Longest response time | 80 |
| 6.3.4 | Reducing the response time with direct I/O access | 81 |
| 6.4 | Calculating method for calculating the cycle/response time | 81 |
| 6.5 | Interrupt response time | 83 |
| 6.5.1 | Overview | 83 |
| 6.5.2 | Reproducibility of Time-Delay and Watchdog Interrupts | 84 |
| 6.6 | Sample calculations | 85 |
| 6.6.1 | Example of cycle time calculation | 85 |
| 6.6.2 | Example of response time calculation | 86 |
| 6.6.3 | Example of interrupt response time calculation | 88 |

| | | |
|----------|--|------------|
| 7 | Technical data | 91 |
| 7.1 | General technical data | 91 |
| 7.1.1 | Rated voltages of S7-300 | 91 |
| 7.1.2 | Technical specifications of the Micro Memory Card | 91 |
| 7.1.3 | Standards and certifications | 92 |
| 7.1.4 | Electromagnetic compatibility | 96 |
| 7.1.5 | Shipping and storage conditions for modules and backup batteries | 98 |
| 7.1.6 | Mechanical and climatic environmental conditions for S7-300 operation | 99 |
| 7.1.7 | Specification of dielectric tests, protection class, degree of protection, and rated voltage of S7-300 | 101 |
| 7.1.8 | Dimension drawing | 102 |
| 7.2 | CPU 315T-2 DP and CPU 317T-2 DP | 103 |
| 7.3 | Integrated Inputs/Outputs for Technology | 114 |
| 7.3.1 | Arrangement of integrated inputs/outputs for integrated technology | 114 |
| A | Appendix..... | 115 |
| A.1 | Information for the Changeover to the Technology CPU | 115 |
| A.1.1 | Scope | 115 |
| A.1.2 | Changed behavior of certain SFCs | 115 |
| A.1.3 | Interrupt events from distributed I/Os while the CPU status is in STOP | 117 |
| A.1.4 | Runtimes that change while the program is running | 117 |
| A.1.5 | Converting the diagnostic addresses of DP slaves | 118 |
| A.1.6 | Reusing existing hardware configurations | 118 |
| A.1.7 | Replacement of a Technology CPU | 119 |
| A.1.8 | Using consistent data areas in the process image of a DP slave system | 119 |
| A.1.9 | Load memory design for the Technology CPU | 120 |
| A.1.10 | PG/OP functions | 120 |
| A.1.11 | Routing for the CPU 31xC/31x as an intelligent slave | 120 |
| A.1.12 | Altered retentive response with a Technology CPU | 120 |
| A.1.13 | FMs/CPs with their own MPI address in a Technology CPU central configuration | 121 |
| | Glossary | 123 |
| | Index..... | 137 |

Product Overview

Introduction

The current trend in the field of automation is toward PLC-integrated solutions. This also applies to technology and motion control applications.

Integrated technology of Technology CPU

With the Technology CPU, technology and motion control functions are integrated in one SIMATIC CPU.

The Technology CPU incorporates:

- SIMATIC CPU 31x-2 DP
- PLCopen-compliant motion control functions
- Technological configurations (technology objects, axis configurations, tools)

The Technology CPU is completely integrated in the SIMATIC family and thus in the TIA environment.

Field of application

The Technology CPU is especially suited to solving the following control tasks:

- Control tasks and technology requirements primarily relating to motion control in the SIMATIC S7-300
- Motion tasks for up to eight coupled axes or single axes
- Technological tasks, e.g. gearing and camming, position-controlled positioning (operating modes: Absolute, relative, additive and superimposed), travel to fixed stop, probe-based print mark correction, position- or time-dependent cam control).

The Technology CPU is designed for use with flow machines, processing/assembly lines, flying shears, labeling equipment, drum feeds or simple gantries (without interpolation).

Interfaces

The Technology CPU has two interfaces:

- One MPI / DP interface, parameterizable as an MPI or DP interface (master or slave).
- one DP(DRIVE) interface for connection of drive systems

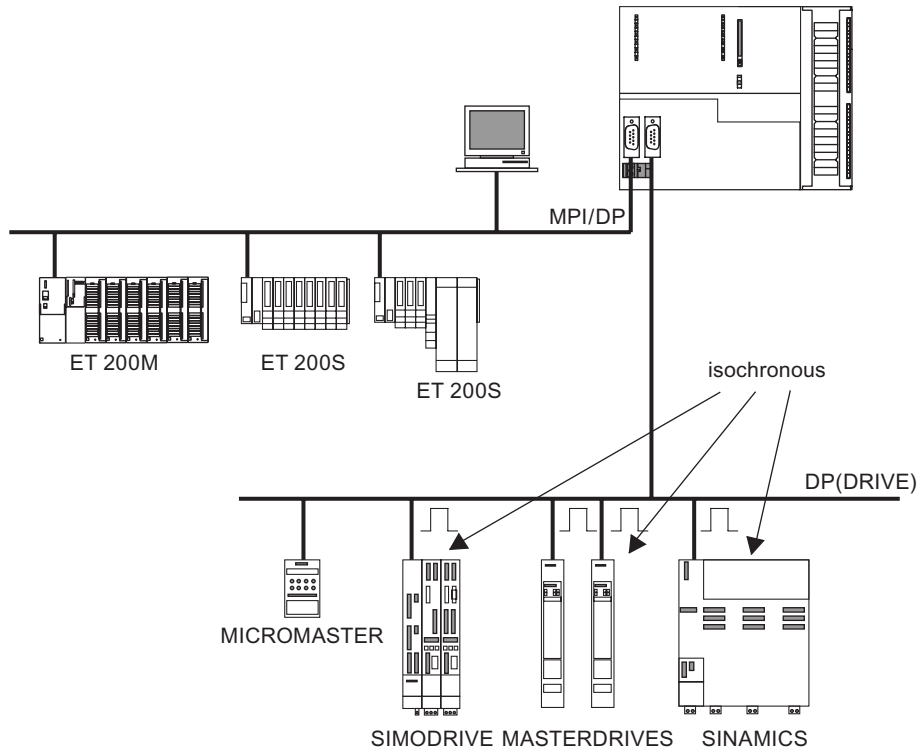

Figure 1-1 Typical configuration with the Technology CPU

MPI / DP interface

The MPI / DP interface is used to connect additional SIMATIC components, such as programming device, OP, S7 controllers and distributed I/O. Extensive networks can be built up in DP interface mode.

DP(DRIVE) interface

The DP(DRIVE) interface is optimized for the connection of drives. It supports all the major SIEMENS drive types:

- MICROMASTER 420/430/440 and COMBIMASTER 411
- SIMODRIVE 611 universal
- SIMODRIVE POSMO CD/SI/CA
- MASTERDRIVES MC/VC
- ET 200M with IM 153-2 (isochronous!) and SM 322 for additional cam output
- ET 200S with IM 151-1 high feature
- SINAMICS S120 (optional with TM15 or TM17 high feature for high-speed cams)
- ADI4 and IM 174 analog drive interfaces (interface for analog drives and stepper motors)
- Isochronous PROFIBUS encoder "SIMODRIVE sensor isochronous"

The components configured in HW Config are displayed in the "Hardware Catalog" window in HW Config. To show the screen, select profile "SIMATIC Technology CPU" in HW Config.

To ensure that the profile's selection list is complete, you must have installed the most recent version of S7-Technology.

The isochronous mode means that even high-speed processes can be controlled with excellent precision.

Integrated inputs and outputs for integrated technology

The Technology CPU has 4 digital inputs and 8 digital outputs integrated. You use these inputs and outputs for technology functions, e.g. reference point acquisition (reference cams) or high-speed output cam switching signals. The inputs and outputs can also be used with technology functions in the *STEP 7* user program.

Configuring and programming

The Technology CPU is configured and programmed completely in *STEP 7* and optional package *S7 Technology* (the *S7 Technology* optional package is integrated after installation in *STEP 7*).

STEP 7 HW Config is the tool used to configure all hardware components of the system (e.g. to create subnets on the two interfaces MPI / DP and DP(DRIVE)) including the drive equipment.

You will need optional package *S7-Technology* to parameterize the so-called "technology objects", e.g. axes, cams, output cams and probes.

The objects are parameterized in specially provided screens. The technology object data are stored in data blocks for use by the *STEP 7* user program.

S7-Technology also includes a library containing PLCopen-compliant standard function blocks which are used to program the motion control tasks themselves. You call these standard FBs in your *STEP 7* user program.

STEP 7 languages LAD, FBD and STL and all the required engineering tools, e.g. S7-SCL or S7-GRAPH are provided to enable you to create the *STEP 7* user program (incl. motion control tasks).

Single-tier configuration

The Technology CPU supports only single-tier configurations.

Operator controls and indicators

Operator controls and indicators of the CPU

The following diagram shows the operator controls and indicators on the Technology CPU.

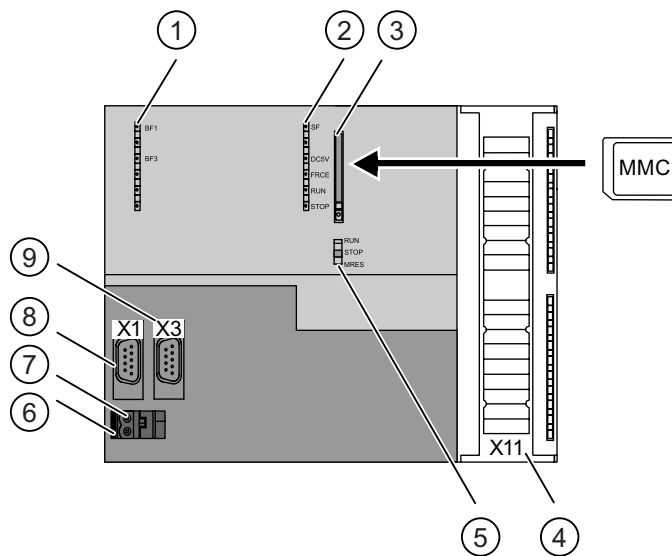

Figure 2-1 Operator controls and indicators of the Technology CPU

Table 2-1 Operator controls and indicators of the Technology CPU

| The number in the diagram | points to the following element on the Technology CPU |
|---------------------------|--|
| 1 | Bus error indicators |
| 2 | Status and error displays |
| 3 | Slot for the SIMATIC Micro Memory Card incl. the ejector |
| 4 | Connection of the integrated I/Os |
| 5 | Mode selector switch |
| 6 | Power supply connection |
| 7 | Grounding slide |
| 8 | Interface X1 MPI / DP |
| 9 | Interface X3 DP(DRIVE) |

Integrated inputs and outputs for integrated technology

You can use the integrated technology inputs and outputs for technology functions and configure them using *S7T Config* (included in the optional package *S7-Technology*).

The digital outputs are provided for high-speed camming functions. They can be programmed with technology functions in the STEP 7 user program. Digital inputs can be used with technology functions such as reference point acquisition (reference cam) as well as with technology functions in the STEP 7 user program.

You use the integrated inputs and outputs for applications in which rapid technological processing is of prime importance.

If you wish to evaluate other inputs and outputs in the STEP 7 user program, they can be interconnected in the usual way by means of supplementary input/output modules.

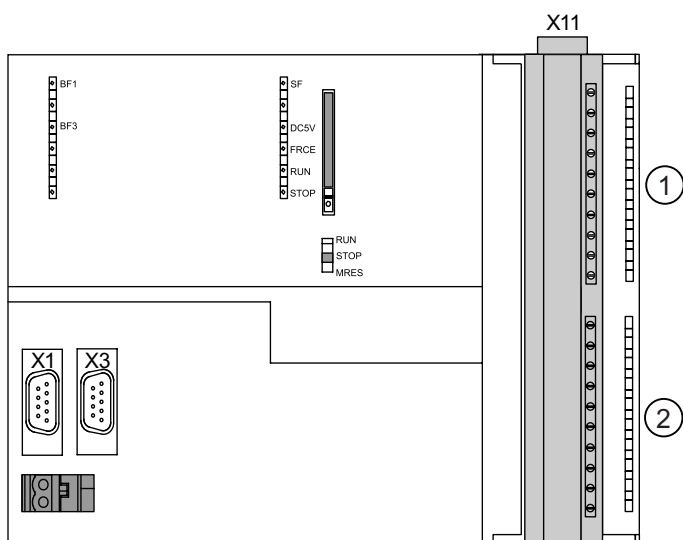

Figure 2-2 Integrated technology inputs and outputs on the Technology CPU with open front door

Table 2-2 Integrated technology inputs and outputs on the Technology CPU

| The number in the diagram | points to the following integrated I/Os |
|---------------------------|---|
| 1 | 4 digital inputs |
| 2 | 8 digital outputs |

Slot for the SIMATIC Micro Memory Card

Memory module is a SIMATIC Micro Memory Card. This can be used as load memory and as a transportable data medium.

Note

The Technology CPU does not have an integrated load memory and therefore requires a SIMATIC Micro Memory Card for operation.

Mode selector switch

You can use the mode selector switch to set the current mode of the CPU.

Table 2-3 Mode selector switch settings

| Position | Meaning | Description |
|----------|------------------|---|
| RUN | RUN mode | The CPU executes the user program. |
| STOP | STOP mode | The CPU does not execute a user program. |
| MRES | CPU memory reset | Mode selector switch position with pushbutton function for CPU memory reset. A CPU memory reset by means of mode selector switch requires a specific sequence of operation. |

Power supply connection

Each CPU is equipped with a double-pole power supply socket. The connector with screw terminals is inserted into this socket when the CPU is delivered.

Status and error displays

The CPU is equipped with the following LEDs:

Table 2-4 Status and error displays of the CPU

| LED designation | Color | Meaning |
|-----------------|--------|---|
| SF | red | Hardware or software error |
| BF1 | red | Bus error at interface (X1) |
| BF3 | Red | Bus error at interface (X3) |
| 5 VDC | Green | 5V power supply for the CPU and the S7-300 bus |
| FRCE | Yellow | LED lights up: Active force job LED flashes at 2 Hz: Node flash test function (only CPUs with firmware V2.2.0 or higher) |
| RUN | green | CPU in RUN. The LED flashes during STARTUP at a rate of 2 Hz, and in HOLD state at 0.5 Hz. |
| STOP | yellow | CPU in STOP, or HOLD, or STARTUP. The LED flashes <ul style="list-style-type: none"> At 0.5 Hz on general reset request At 2 Hz during general reset At 2 Hz during shutdown (LED RUN lit). |

Shutdown

What happens during shutdown?

1. The control of the Technology CPU is already in STOP mode during "shutdown". The outputs of the centralized and distributed I/Os on the MPI / DP are deactivated. The "STOP" LED flashes at 2 Hz. The "RUN" LED lights up.
2. The integrated inputs/outputs for integrated technology and the distributed I/Os on DP(DRIVE) are still active during shutdown.
3. The integrated technology of the Technology CPU shuts down the drives on PROFIBUS DP(DRIVE) in a controlled manner.
4. The integrated technology then also switches to STOP. The integrated inputs/outputs for integrated technology and the distributed I/Os on DP(DRIVE) are deactivated. The "STOP" LED lights up.

The maximum duration of shutdown depends on your configuration in S7T Config.



CAUTION

The distributed I/Os on DP(DRIVE) cannot be controlled from the user program during "shutdown". The outputs which can be controlled with technology function "MC_WritePeripherie" retain their last current setting.

Reference

Further information

- about CPU operating modes can be found in the *STEP 7 Online Help*.
- for operating the mode selector switch for resetting, refer to the S7-300, CPU 31xC, and CPU 31x Operating Instructions: Configuration, section *Commissioning*
- for evaluating the LEDs in the event of an error / diagnostics, refer to the S7-300, CPU 31xC, and CPU 31x Operating Instructions: Configuration, section *Debugging functions, diagnostics and troubleshooting*.
- to use the SIMATIC MMCs and the memory concept refer to the section *Memory Concept*.

Setting up an S7-300 with a Technology CPU

3.1 Overview

This section gives you additional information to that covered in the S7-300, CPU 31xC and CPU 31x Operating Instructions: Configuration, deviations, etc. that you will also require.

3.2 S7-300 components

Sample configuration of an S7-300:

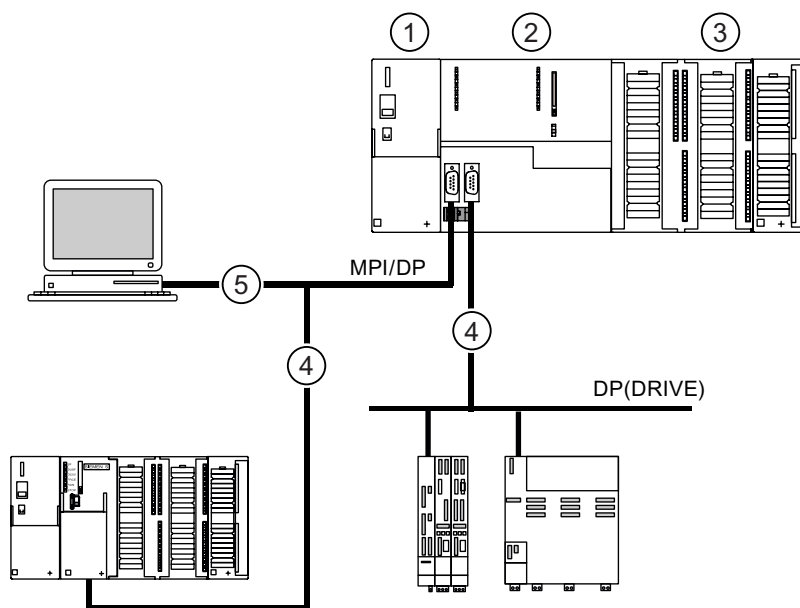

Table 3-1 S7-300 components

| The number in the diagram | points for the following component of an S7-300 system |
|---------------------------|--|
| (1) | Power supply (PS) module |
| (2) | Central processing unit (CPU) |
| (3) | Signal module (SM) |
| (4) | PROFIBUS cable |
| (5) | Cable for connecting a programming device (PG) or for networking with other SIMATIC controls |

3.3 Configuring

You use a programming device (PG) to program the S7-300. You connect the programming device to the CPU by means of a programming device cable.

Using the PROFIBUS bus cable, you connect the CPU

- To other SIMATIC controls via the MPI / DP interface
- To the drives via the DP(DRIVE) interface.

No programming device / OP on DP(DRIVE)

We recommend that you do not connect a programming device / OP to DP(DRIVE).

Reason: If you connect a programming device / OP to DP(DRIVE), the properties of DP(DRIVE) change (for example isochronism), and the synchronism between drives may be lost as a result. Always therefore connect a programming device / OP to the MPI / DP interface and access the DP(DRIVE) via the "Routing" function.

3.3 Configuring

3.3.1 Single-tier configuration

The Technology CPU supports only single-tier configurations.

3.3.2 Subnets

Overview: Subnets with the Technology CPU

The Technology CPU provides the following subnets:

- Multi Point Interface (MPI) or PROFIBUS DP
- DP(DRIVE): Optimized for drives

Transmission rate

Maximum transmission rates:

- MPI/PROFIBUS DP: 12 Mbaud
We recommend that you set 12 Mbaud for the Technology CPU
- DP(DRIVE): 12 Mbaud

Note

Before you transfer projects to the Technology CPU via the MPI/DP interface, you should increase the baud rate to at least 1.5 Mbaud or else the data transmission can take a very long time (up to 15 minutes at 187.5 kbaud).

Number of nodes

Maximum number of nodes per subnet:

Table 3-2 Subnet nodes

| Parameters | MPI | PROFIBUS DP | PROFIBUS DP (DRIVE) |
|------------|---|---|--|
| Number | 127 | 126 | 33 |
| Addresses | 0 to 126 | 0 to 125 | 1 to 125 |
| Comments | Default: 32 addresses Reserved addresses: <ul style="list-style-type: none"> • Address 0 for PG • Address 1 for OP | of which: 1 master (reserved) 1 PG connection (address 0 reserved) 124 slaves or other masters | of which: <ul style="list-style-type: none"> • 1 master (reserved) and 32 slaves or drives |

3.4 Addressing

Slot-specific addressing of modules

The Technology CPU is assigned to two slot numbers: 2 and 3.

The input and output addresses for I/O modules begin at the same module start address.

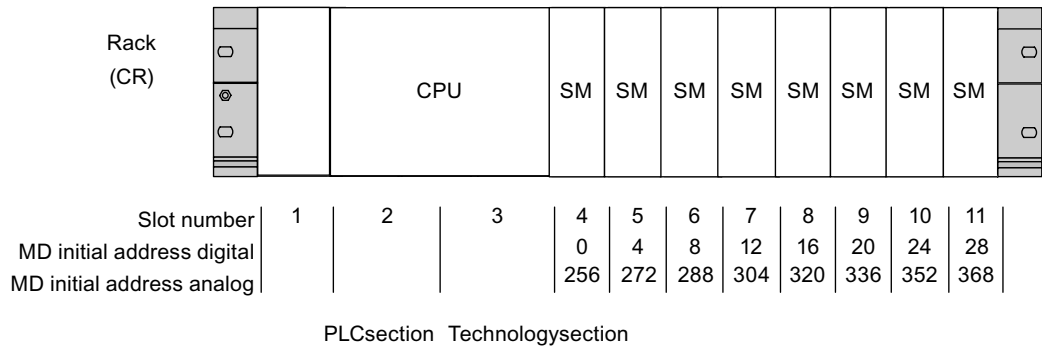

Figure 3-1 Slots of the S7-300 with Technology CPU and associated module start addresses

Integrated inputs and outputs for integrated technology

The Technology CPU has 4 integrated digital inputs and 8 integrated digital outputs for integrated technology. You use these integrated inputs and outputs for technology functions, e.g. reference point acquisition (reference cams) or high-speed output cam switching signals.

The integrated inputs and outputs can also be used with technology function in the STEP 7 user program.

You use the integrated inputs and outputs for applications in which rapid technological processing is of prime importance.

3.5 Commissioning

Requirements

If you wish to utilize the full scope of CPU functions, you will require

- STEP 7 and the *S7-Technology* optional package
- S7-300 is installed
- S7-300 is wired
- For a networked S7-300:
 - MPI/PROFIBUS addresses are set
 - Terminating resistors on the segments are enabled

3.6 Operating system

Technology CPU operating system

To meet the requirements of the integrated technology, technology functions have been added to the standard CPU operating system to obtain the technology operating system.

The technology operating system is included in the project and the configuration. In other words, if you load a project created with S7-Technology to the Technology CPU, the technology operating system is automatically transferred at the same time.

Updating the operating system

You can order the latest operating system versions from your Siemens contact or download it from the Internet at (Siemens Homepage; Industrial Automation, Customer Support).

3.7 Status and error displays

Status and error displays of the Technology CPU

Table 3-3 Status and error displays of the Technology CPU

| LED | | | | | Meaning |
|---------|---------|-------------------------|------------------|------------------|---|
| SF | 5 VDC | FRCE | RUN | STOP | |
| Off | Off | Off | Off | Off | CPU power supply missing. Remedy: Check whether the power supply module is connected to mains and switched on. Check whether the CPU is connected to the power supply and switched on. |
| Off | On | X (see the description) | Off | On | The CPU is in STOP mode. Remedy: Start the CPU. |
| On | On | X | Off | On | The CPU is in STOP mode as a result of error. Remedy: refer to the tables below, evaluation of the SF LED |
| X | On | X | Off | Flashes (0.5 Hz) | The CPU requests memory reset. |
| X | On | X | Off | Flashes (2 Hz) | The CPU executes memory reset. |
| X | On | X | Flashes (2 Hz) | On | The CPU is in startup mode. |
| X | On | X | Flashes (0.5 Hz) | On | The CPU was halted by a programmed break point. For details, refer to the Programming Manual <i>Programming with STEP 7</i> . |
| On | On | X | X | X | Hardware or software error Remedy: refer to the tables below, evaluation of the SF LED |
| X | X | On | X | X | You enabled the Force function For details refer to the Programming Manual <i>Programming with STEP 7</i> . |
| X | X | X | On | Flashes (2 Hz) | STOP/shutdown What happens during shutdown? The control of the Technology CPU is already in STOP mode during "shutdown". The outputs of the centralized and distributed I/Os are deactivated. The integrated inputs/outputs for integrated technology and the ET 200M on the DP(DRIVE) are still active during shutdown. The integrated technology of the Technology CPU shuts down the drives on PROFIBUS DP(DRIVE) in a controlled manner. The integrated technology of the CPU then also goes into STOP. The integrated inputs/outputs for integrated technology and the ET 200M on the DP(DRIVE) are deactivated. The maximum duration of shutdown depends on your configuration in S7TConfig. |
| X | X | X | Flashes (0.5 Hz) | Flashes (2 Hz) | HOLD/shutdown |
| Flashes | Flashes | Flashes | Flashes | Flashes | Internal errors in Technology CPU. Contact your local SIEMENS partner. |

Status and error displays for DP or DP(DRIVE)

Table 3-4 LEDs BF1 and BF3

| LED | | Meaning |
|-------------|-------------|--|
| BF1 | BF3 | |
| On/ flashes | X | Error on the PROFIBUS DP interface of the Technology CPU. Remedy: See table LED BF1 illuminated |
| X | On/ flashes | Error on the DP(DRIVE) interface Remedy: See table LED BF1 flashing |

Description of status X:

The LED can assume the On or Off state. This status, however, is irrelevant for the current CPU function. For example, the states Force On or Off do not influence the CPU STOP status

Table 3-5 LED BF1 illuminated

| Possible Errors | CPU reaction | Possible Remedies |
|---|---|---|
| <ul style="list-style-type: none"> • Bus fault (hardware fault) • DP interface error • Different transmission rates in multiple DP master mode. • If the DP slave / master interface is active: Short-circuit on the bus. • With passive DP slave interface: transmission rate search, i.e. there are no other active nodes on the bus (a master, for example) | Call of OB 86 (when CPU is in RUN mode). CPU switches to STOP if OB 86 is not loaded. | <ul style="list-style-type: none"> • Check the bus cable for short-circuit or breaks. • Evaluate the diagnostics. Reconfigure or correct the configuration. |

Table 3-6 LED BF1 flashes

| Possible errors | CPU reaction | Possible remedies |
|---|---|---|
| The CPU is DP master / active slave: <ul style="list-style-type: none"> • Failure of a connected station • At least one of the configured slaves cannot be accessed. • Incorrect configuration | Call of OB 86 (when CPU is in RUN mode). CPU switches to STOP if OB 86 is not loaded. | Verify that the bus cable is connected to the CPU, or that the bus is not interrupted. Wait until the CPU has completed its startup. If the LED does not stop flashing, check the DP slaves or analyze the diagnostic data of the DP slaves. |
| The CPU is a DP slave The CPU parameters are incorrectly set. Possible causes: <ul style="list-style-type: none"> • The response monitoring period has elapsed. • PROFIBUS DP communication is down. • Wrong PROFIBUS address. • Incorrect configuration | Call of OB 86 (if CPU is in RUN mode). CPU switches to STOP if OB 86 is not loaded. | <ul style="list-style-type: none"> • Check the CPU. • Verify that the bus connector is properly seated. • Check whether the bus cable to the DP master has been disconnected. • Check the configuration and parameter assignment. |

Table 3-7 LED BF3 illuminated

| Possible errors | CPU reaction | Possible remedies |
|---|---|---|
| <ul style="list-style-type: none">• Bus fault (hardware fault)• DP interface error | Error message in the technology DB configured by you. | Check for short-circuit or interruption in the bus cable. |

Table 3-8 LED BF3 flashes

| Possible Errors | CPU reaction | Possible Remedies |
|--|---|---|
| <ul style="list-style-type: none">• Failure of a connected station• At least one of the configured slaves cannot be accessed.• Incorrect configuration | Error message in the technology DB configured by you. | Verify that the bus cable is connected to the CPU, or that the bus is not interrupted. Wait until the CPU has completed its startup. If the LED does not stop flashing, check the DP slaves or analyze the diagnostic data of the DP slaves. |

Communication with S7-300

4.1 Interfaces

4.1.1 Overview

The Technology CPU has two interfaces:

- MPI / DP interface (X1)
- PROFIBUS DP(DRIVE) interface (X3)

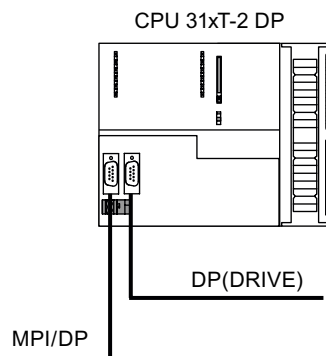

Figure 4-1 Technology CPU interfaces

4.1 Interfaces

4.1.2 MPI/DP interface (X1)

Availability

The Technology CPU features an MPI / DP interface (X1). A CPU with MPI / DP interface is supplied with default MPI parameter settings. Depending on your requirements, you may need to reconfigure the interface as a DP interface in STEP 7.

Operating modes

Possible interface operating modes:

- MPI
- DP master
- DP slave

Time Synchronization using MPI

The CPU's MPI interface supports time synchronization. The CPU can be programmed for operation as time master (with default synchronization intervals) or time slave.

Default setting: No time synchronization

The synchronization mode is set in the "Clock" tab of the CPU or interface properties dialog box in HW Config.

When operated as **time slave**, the CPU receives a synchronization message frame from one time master and sets its internal time accordingly.

When operated as **time master**, the CPU broadcasts time synchronization message frames at programmed synchronization intervals at the MPI interface to other node stations of the MPI subnet.

In order for the CPU to synchronize the connected time slaves, you must set the CPU time at least once.

You can set the time of day by means of:

- Programming device functions
- SFC call or
- A different time master

Please note that in the supply state or after a firmware update the CPU is not yet set and therefore no synchronization of the connected time slaves can take place.

Time synchronization at the MPI interface is also available at:

- At the DP Interface
- In the AS of the central configuration

Note

The CPU may only be operated as time slave at one of these interfaces.

Example

A CPU operating as time slave on the MPI interface can only operate as time master within the AS.

MPI properties

The MPI (Multi-Point Interface) represents the CPU interface for PG/OP connections, or for communication on an MPI subnet.

The default transmission rate of all CPUs is 187.5 kbps. You can also set 19.2 kbps for communication with an S7-200. You can set baud rates of up to 12 Mbaud.

The CPU automatically broadcasts its bus configuration via the MPI interface (the transmission rate, for example). A PG, for example, can thus receive the correct parameters and automatically connect to a MPI subnet.

Note

You may only connect PGs to an MPI subnet which is in RUN. Other stations (for example, OP, TD, ...) should not be connected to the MPI subnet while the system is in RUN. Otherwise, transferred data might be corrupted as a result interference, or global data packages may be lost.

Note

Before you transfer data to the CPU via the MPI interface, you should increase the baud rate to 1.5 Mbaud or else the data transmission can take a very long time (up to 15 minutes at 187.5 kbaud)!

Devices capable of MPI communication

- PG/PC
- OP/TP
- S7-300 / S7-400 with MPI interface
- S7-200 (with 19.2 kbaud only)

Properties of PROFIBUS DP

The PROFIBUS DP interface is mainly used to connect distributed I/O. PROFIBUS DP allows you to create extensive subnets, for example.

The PROFIBUS DP interface can be set for operation in master or slave mode, and supports transmission rates up to 12 Mbaud.

The CPU broadcasts its bus parameters (transmission rate, for example) via the PROFIBUS DP interface when master mode is set. A PG, for example, can thus receive the correct parameters and automatically connect to a PROFIBUS subnet. In your configuration you can specify to disable bus parameter broadcasting.

Devices capable of PROFIBUS DP communication

- PG/PC
- OP/TD
- DP slaves
- DP master
- Actuators/sensors
- S7-300/S7-400 with PROFIBUS DP interface

Time synchronization via PROFIBUS DP

Time synchronization is possible via the CPU's PROFIBUS interface. The CPU can be programmed for operation as time master (with default synchronization intervals) or time slave.

Default setting: No time synchronization

The synchronization mode is set in the "Clock" tab of the CPU or interface properties dialog box in HW Config.

When operated as **time slave**, the CPU receives a synchronization message frame from one time master and sets its internal time accordingly.

When operated as **time master**, the CPU on the PROFIBUS DP interface broadcasts time synchronization message frames at programmed synchronization intervals to other node stations in the connected PROFIBUS DP subnet. In order for the CPU to synchronize the connected times slaves, you must set the CPU time at least once.

You can set the time of day by means of:

- Programming device functions
- SFC call or
- A different time master

Please note that in the supply state or after a firmware update the CPU is not yet set and therefore no synchronization of the connected time slaves can take place.

Alongside the time synchronization on the PROFIBUS DP interface, time synchronization is also available at:

- the MPI Interface
- In the AS of the central configuration

Note

The CPU may only be operated as time slave at one of these interfaces

Example

If the CPU is operating as time slave on the DP interface, it can only operate as time master within the automation system.

4.1.3 PROFIBUS DP (DRIVE) interface (X3)

Properties

The PROFIBUS DP (DRIVE) interface is used to connect to drive systems. You can connect drive systems in accordance with the PROFIdrive.

The PROFIBUS DP(DRIVE) interface is configured as a master and supports transmission rates up to 12 Mbaud.

The PROFIBUS DP (DRIVE) interface support isochronous mode.

The CPU sends its bus parameter settings (e.g. baud rate) via the PROFIBUS DP (DRIVE) interface. In your configuration you can specify to disable bus parameter broadcasting.

Using the "Routing" function, you can access the drive parameters of the slaves in the DP(DRIVE) line for the purposes of commissioning and diagnostics. However, diagnostics cannot be performed via PROFIBUS DP (DRIVE) from the *STEP 7* user program.

Note

If you deselect "Startup with different target / actual configurations" in the Technology CPU properties in STEP 7, then the Technology CPU will boot even if the stations configured on DP-DRIVE are missing.

Connectable devices

You can connect drives to PROFIBUS DP (DRIVE), e.g.:

- MICROMASTER 420/430/440 and COMBIMASTER 411
- SIMODRIVE 611 universal
- SIMODRIVE POSMO CD/SI/CA
- MASTERDRIVES MC/VC
- ET 200M with IM 153-2 (isochronous!) and SM 322 for additional cam output
- ET 200S with IM 151-1 high feature
- SINAMICS S120/G120 (optional with TM15 or TM17 high feature for high-speed cams)
- PROFIBUS module IM 174 (interface for analog drives and stepper motors)
- ADI4 (analog drive interface)
- Isochronous PROFIBUS encoder "SIMODRIVE sensor isochronous"

The components configured in HW Config are displayed in the "Hardware Catalog" window in HW Config. To show the screen, select profile "SIMATIC Technology CPU" in HW Config.

To ensure that the profile's selection list is complete, you must have installed the most recent version of S7-Technology.

Non-connectable devices

We would not recommend operating active PROFIBUS stations (PGs, PCs, OPs, TDs, etc.) on PROFIBUS DP(DRIVE). The DP cycle will be burdened by additional access times if you do operate these PROFIBUS stations on DP(DRIVE). In this case, isochronous processing of drive information cannot be guaranteed.

Always therefore connect a PG/OP to the MPI / DP interface and access the DP(DRIVE) via the "Routing" function.

4.1.4 Information about interface X3 DP(DRIVE)

Interface X3 assigned to DP(DRIVE)

Note that the 2nd interface on the Technology CPU is assigned to PROFIBUS DP(DRIVE), i.e. it cannot be used as the second interface for PROFIBUS DP.

No diagnostics on DP(DRIVE)

Remember that you cannot evaluate diagnostic data from DP(DRIVE) in your STEP 7 user program if you are using the Technology CPU.

However, with your PC/PG connected to PROFIBUS DP, you can use the "routing" function to access drive parameters in the DP(DRIVE) line (in conjunction with appropriate drive tools) for commissioning and diagnostic purposes.

4.2 Communication services

4.2.1 Overview

Selecting the communication service

You need to decide on a communication service, based on functionality requirements. Your choice of communication service will influence

- the functionality available,
- whether an S7 connection is required or not, and
- the connection timing.

The user interface can vary considerably (SFC, SFB, ...), and is also determined by the hardware used (SIMATIC CPU, PC, ...).

Overview of communication services

The table below provides an overview of communication services offered by the CPU.

Table 4-1 CPU communication services

| Communication service | Functionality | Time at which the S7 connection is established ... | via MPI | via DP | to DP(DRIVE) |
|---------------------------|---|---|---------|--------|--------------|
| PG communication | Commissioning, test, diagnostics | from the PG, starting when the service is being used | X | X | - |
| OP communication | Operator control and process monitoring | from the OP at Power ON | X | X | - |
| S7 basic communication | Data exchange | is programmed at the blocks (SFC parameters) | X | - | - |
| S7 communication | Data exchange | as server only, communication link is set up by the communication partner | X | X | - |
| Global data communication | Cyclic data exchange (for example, flag bits) | does not require an S7 connection | X | - | - |
| Routing PG functions* | for example testing, diagnostics on other networks also | from the PG, starting when the service is being used | X | X | X |

* Functions can be routed only to DP(DRIVE), but not on DP(DRIVE)!

4.2.2 PG communication

Properties

PG communication is used to exchange data between engineering stations (for example programming device, PC) and SIMATIC modules that are capable of communication. This service is available for MPI, PROFIBUS and Industrial Ethernet subnets. Transition between subnets is also supported.

PG communication provides the functions needed to download / upload programs and configuration data, to run tests and to evaluate diagnostic information. These functions are integrated in the operating system of SIMATIC S7 modules.

A CPU can maintain several simultaneous online connections to one or multiple PGs.

4.2.3 OP communication

Properties

OP communication is used to exchange data between operator stations (for example OP, TP) and SIMATIC modules that are capable of communication. This service is available for MPI, PROFIBUS and Industrial Ethernet subnets.

OP communication provides functions you require for monitoring and modifying. These functions are integrated in the operating system of SIMATIC S7 modules.

A CPU can maintain several simultaneous connections to one or several OPs.

4.2.4 S7 basic communication

Properties

S7-based communication is used to exchange data between S7 CPUs and the communication-capable SIMATIC modules within an S7 station (acknowledged data communication). Data are exchanged across non-configured S7 connections. The service is available via MPI subnet, or within the station to function modules (FM).

S7-based communication provides the functions you require for data exchange. These functions are integrated into the CPU operating system.

You can utilize this service by means of "System function" (SFC) user interface.

Reference

Further information

- on SFCs can be found in the *Instruction list*, for more details refer to the *STEP 7 online help* or to the *System and Standard Functions* reference manual.
- on communication can be found in the *Communication with SIMATIC* manual.

4.2.5 S7 communication

Properties

A CPU can always operate in server or client mode in S7 communication: We distinguish between

- Communication with unilateral configuration (for PUT/GET only)
- Communication with bilateral configuration (for USEND, URCV, BSEND, BRCV, PUT, GET)

However, the functionality depends on the CPU. A CP is therefore required in certain situations.

Table 4-2 Client and server in S7 communication, using connections with unilateral / bilateral configuration

| CPU | Use in server mode for connections with unilateral configuration | Use in server mode for connections with bilateral configuration | Use as client |
|------------|--|---|---|
| 31x T-2 DP | Generally possible on MPI / DP interface without configuration of user interface | Only possible with CP and loadable FBs. | Only possible with CP and loadable FBs. |

The user interface is implemented using standard function modules (FBs) from the standard library of STEP 7, under communication blocks.

Further information on communication can be found in the *Communication with SIMATIC Manual*.

4.2.6 Global data communication (MPI only)

Properties

Global data communication is used for cyclic exchange of global data (for example, I, Q, M) between SIMATIC S7 CPUs (data exchange without acknowledgement). One CPU broadcasts its data to all other CPUs on the MPI subnet. This function is integrated in the CPU operating system.

Reduction factor

The reduction ratio specifies the cyclic intervals for GD communication. You can set the reduction ratio when you configure global data communication in *STEP 7*. For example, if you set a reduction ratio of 7, global data are transferred only with every 7th cycle. This reduces CPU load.

Send and receive conditions

Conditions which should be satisfied for GD communication:

- The transmitter of a GD packet must meet the following requirement:
Reduction ratio_{transmitter} x cycle time_{transmitter} ≥ 60 ms
- The receiver of a GD packet must meet the following requirement:
Reduction factor_{receiver} x cycle time_{receiver}
< reduction factor_{transmitter} x cycle time_{transmitter}

A GD packet may be lost if there requirements are not met. The reasons being:

- the performance of the "smallest" CPU in the GD circuit
- asynchronous transmitting / receiving of global data at the stations

When setting in *STEP 7*: "Transmit after each CPU cycle", and the CPU has a short scan cycle time (< 60 ms), the operating system might overwrite a GD packet of the CPU before it is transmitted. The loss of global data is indicated in the status box of a GD circuit, if you set this function in your *STEP 7* configuration.

GD resources of the CPUs

Table 4-3 GD resources of the CPUs

| Parameters | CPU 31xT-2 DP |
|---|---------------|
| Number of GD circuits per CPU | Max. 8 |
| GD packets transmitted per GD circuit | Max. 1 |
| GD packets transmitted by all GD circuits | Max. 8 |
| GD packets received per GD circuit | Max. 1 |
| GD packets received by all GD circuits | Max. 8 |
| Data length per GD packet | Max. 22 bytes |
| Consistency | Max. 22 bytes |
| Min. reduction ratio (default) | 1 (8) |

4.2.7 Routing

Definition

The routing function enables you to attach a PG/PC at any point in the network and establish a connection to all drives accessible via gateways.

Accessing drives in a DP(DRIVE) subnet from a PG/PC

Test, diagnostic and parameterizing functions can be routed via the MPI / DP interface (X1) to the DP(DRIVE) subnet with the Technology CPU.

The Technology CPU provides a certain number of connection resources for routing. These connections are available in addition to the S7 connection resources.

The number of routing connections can be found in the Technical Specifications.

Network gateway

Gateways between subnets are routed in a SIMATIC station that is equipped with interfaces to the respective subnets. The figure below shows the Technology CPU (DP master) acting as router for subnets 1 and 2.

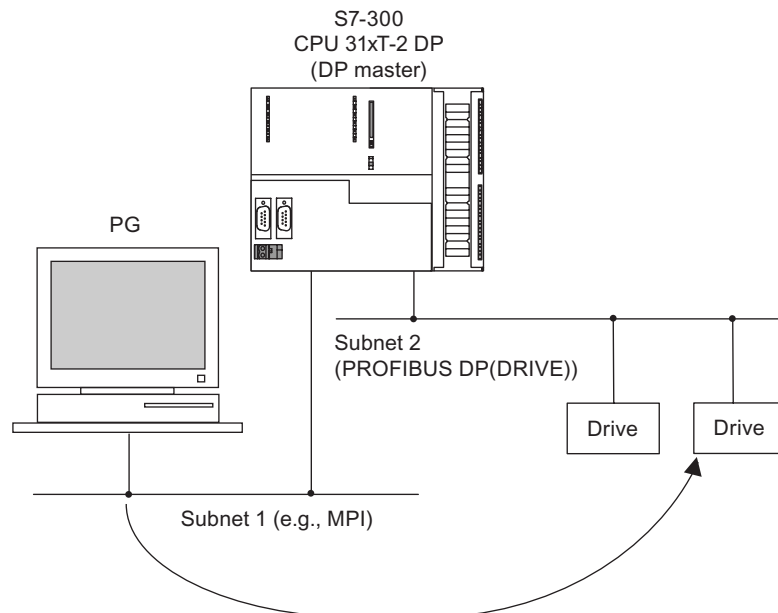

Figure 4-2 Routing - network gateway

Requirements for routing

- The station modules are "capable of routing" (CPUs or CPs).
- The network configuration does not exceed project limits.
- The modules have loaded the configuration data containing the latest "knowledge" of the entire network configuration of the project.

Reason: All modules participating in the network transition must receive the routing information defining the paths to other subnets.

- In your network configuration, the PG/PC you want to use to establish a connection via network node must be assigned to the network it is physically connected to.

Example of an application: TeleService

The figure below shows the example of an application for remote maintenance of an S7 station using a PG. The connection to other subnets is here established via modem connection.

The lower section of the figure shows how to configure this in *STEP 7*.

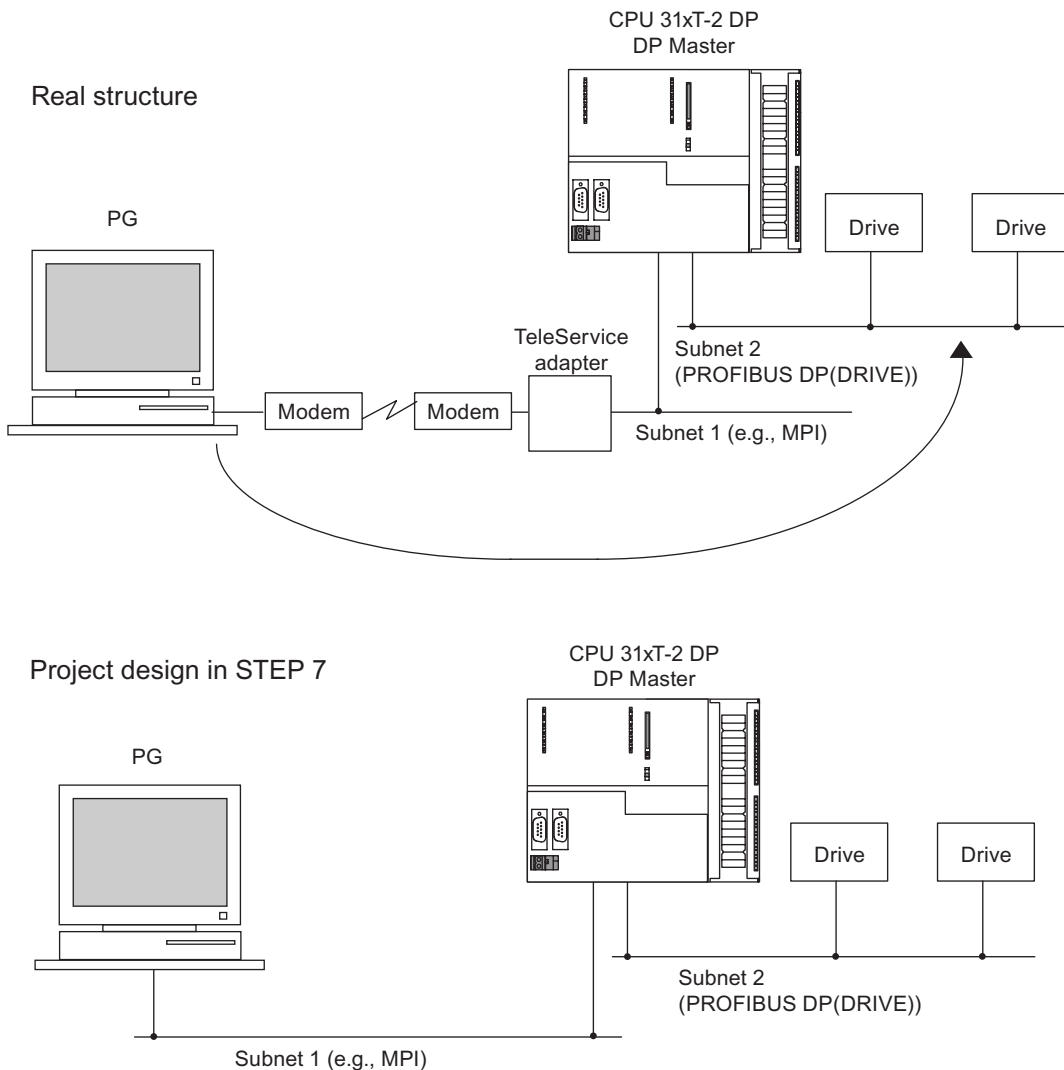

Figure 4-3 Routing - example of TeleService application

Reference

Further information

- about setting the PG/PC interface for routing can be found in Getting Started *CPU 317T-2 DP: Controlling a SINAMICS S120* in chapter *Configuring the PG/PC Interface*.
- about routing can be found in the *Programming with STEP 7* manual, or directly to the *STEP 7* online help.
- about configuring with *STEP 7* can be found in the *Configuring Hardware and Connections in STEP 7* manual
- fundamentals can be found in the *Communication with SIMATIC* Manual.
- about TeleService adapters can be found at Internet website <http://www.ad.siemens.de/support> with article ID 14053309 (documentation).
- on SFCs can be found in the *Instruction list*, for more details refer to the *STEP 7 online help* or to the *System and Standard Functions* reference manual.
- on communication can be found in the *Communication with SIMATIC* manual.

4.2.8 Data consistency

Properties

A data area is consistent if it can be read or written to from the operating system as a consistent block. Data exchanged collectively between the stations should belong together and originate from a single processing cycle, that is, be consistent.

If the user program contains a programmed communication function, for example, access to shared data with XSEND/ XRCV, access to that data area can be coordinated by means of the "BUSY" parameter itself.

With PUT/GET functions

For S7 communication functions, such as PUT/GET or write / read via OP communication, which do not require a block in the user program on the CPU (operating in server mode), allowances must be made in the program for the extent of the data consistency.

The PUT/GET functions for S7 communication, or for reading/writing variables via OP communication, are executed at the CPU's scan cycle checkpoint.

In order to ensure a defined process interrupt reaction time, communication variables are copied consistently in blocks of maximum 160 bytes to/from the user memory at the scan cycle check point of the operating system. Data consistency is not guaranteed for larger data areas.

Note

Where defined data consistency is required, the length of communication variables in the CPU's user program may not exceed 160 bytes.

4.3 S7 connections

4.3.1 S7 connection as communication path

An S7 connection is established when S7 modules communicate with one another. This S7 connection is the communication path.

Note

Global data communication and the communication via PROFIBUS DP do not require S7 connections.

Every communication link requires S7 connection resources on the CPU for the entire duration of this connection.

Hence, every S7 CPU provides a specific number of S7 connection resources. These are used by various communication services (PG/OP communication, S7 communication or S7 basic communication).

Connection points

An S7 connection between modules with communication capability is established between connection points. The S7 connection always has two connection points: The active and passive connection points:

- The active connection point is assigned to the module that establishes the S7 connection.
- The passive connection point is assigned to the module that accepts the S7 connection.

Any module that is capable of communication can thus act as an S7 connection point. At the connection point, the established communication link always uses **one** S7 connection of the module concerned.

Transition point

If you use the routing functionality, the S7 connection between two modules capable of communication is established across a number of subnets. These subnets are interconnected via a network transition. The module that implements this network transition is known as a router. The router is thus the point through which an S7 connection passes.

Any CPU with a DP interface can be the router for an S7 connection. You can establish a certain maximum number of routing connections. This does not limit the data volume of the S7 connections.

The number of routing connections can be found in the Technical Specifications.

4.3.2 Assignment of S7 connections

There are several ways to allocate S7 connections on a communication-capable module:

- Reservation during configuration
- Assigning connections in the program
- Allocating connections during commissioning, testing and diagnostics routines
- Allocating connection resources to OCMS services

Reservation during configuration

One connection resource each is automatically reserved on the CPU for PG and OP communication. Whenever you need more connection resources (for example, when connecting several OPs), this increases in the CPU properties dialog box in STEP 7.

Connections must also be configured (using NetPro) for the use of S7 communication. For this purpose, connection resources have to be available that are not allocated to PG/OP or other connections. The required S7 connections are then permanently allocated for S7 communication when the configuration is uploaded to the CPU.

Assigning connections in the program

In the case of S7 basic communication, the connection is set up by the user program. The CPU operating system initiates connection setup and the relevant S7 connections are assigned.

Using connections for commissioning, testing and diagnostics

An active online function on the engineering station (PG/PC with *STEP 7*) occupies S7 connections for PG communication:

- An S7 connection resource for PG communication which was reserved in your CPU hardware configuration is assigned to the engineering station, that is, it only needs to be allocated.
- If all reserved S7 connection resources for PG communication are allocated, the operating system assigns a free S7 connection resource which has not yet been reserved. If no more connection resources are available, the engineering station cannot go online to the CPU.

Allocating connection resources to OCMS services

An online function of the OCM station (OP/TD/... with *WinCC*) allocates S7 connections for the OP communication:

- An S7 connection resource for OP communication you have reserved in your CPU hardware configuration is therefore assigned to the OCM station engineering station, that is, it only needs to be allocated.
- If all reserved S7 connection resources for OP communication are allocated, the operating system automatically assigns a free S7 connection resource which has not yet been reserved. If no more connection resources are available, the OCM station cannot go online to the CPU.

Time sequence for allocation of S7 connection resources

When you program your project in *STEP 7*, the system generates parameter assignment blocks which are read by the modules in the startup phase. This allows the module's operating system to reserve or allocate the relevant S7 connection resources. That is, for instance, OPs cannot access a reserved S7 connection resource for PG communication.

The module's (CPU) S7 connection resources which were not reserved can be used freely. These S7 connection resources are allocated in the order they are requested.

Example

If there is only one free S7 connection left on the CPU, you can still connect a PG to the bus. The PG can then communicate with the CPU. The S7 connection is only used, however, when the PG is communicating with the CPU.

If you connect an OP to the bus while the PG is not communicating, the OP can establish a connection to the CPU. Since an OP maintains its communication link at all times, in contrast to the PG, you cannot subsequently establish another connection via the PG.

4.3.3 Distribution and availability of S7 connection resources

Distribution of connection resources

The distribution of the S7 connections of the CPUs can be found in the following table:

Table 4-4 Distribution of connections

| Communication service | Distribution |
|---|--|
| PG communication OP communication S7 basic communication | In order to avoid allocation of the S7 connections being dependent only on the chronological sequence in which various communication services are requested, connections can be reserved for these services. For PG and OP communication respectively, at least one connection resource is reserved by default. In the table below, and in the technical data of the CPUs, you can find the configurable connection resources and the default settings for each CPU. You "redistribute" connection resources by setting the relevant CPU parameters in <i>STEP 7</i> . |
| S7 communication Other communication connections (e.g. via CP 343-1, with a data lengths of > 240 bytes) | Available connection resources that are not specially reserved for a service (programming device / OP communication, S7 basic communication) are used for this. |
| Routing PG functions | The CPU provides a certain number of connection resources for routing. These connections are available in addition to the connection resources. The number of routing connections can be found in the Technical Specifications. |
| Global data communication | These communication services do not use S7 connections. |
| PROFIBUS DP | This communication service requires no S7 connection resources. |

Availability of connection resources

The following table shows the available connection resources.

Table 4-5 Availability of connection resources

| CPU | Total number connection resources | Reserved for | | | Free S7 connections |
|-----------|-----------------------------------|--------------------|--------------------|------------------------|---|
| | | PG communication | OP communication | S7 basic communication | |
| 315T-2 DP | 16 | 1 to 15, default 1 | 1 to 15, default 1 | 0 to 12, default 0 | Displays all non-reserved S7 connections as free connections. |
| 317T-2 DP | 32 | 1 to 31, default 1 | 1 to 31, default 1 | 0 to 30, default 0 | |

Note

When using a CPU 315T-2 DP, you can configure up to 14 connection resources for S7 communication in NetPro. These connections are then reserved. When using a CPU 317T-2 DP, you can configure up to 16 connection resources for S7 communication in NetPro.

4.4 DPV1

4.4.1 General information about DPV1

New automation and process engineering tasks require the range of functions performed by the existing DP protocol to be extended. In addition to cyclical communication functions, acyclical access to non-S7 field devices is another important requirement of our customers, and was implemented in the standard EN 50170. In the past, acyclical access was only possible with S7 slaves. The distributed I/O standard EN 50170 has been further developed. All the changes concerning new DPV1 functions are included in IEC 61158/ EN 50170, volume 2, PROFIBUS.

Definition DPV1

The term DPV1 is defined as a functional extension of the acyclical services (to include new interrupts, for example) provided by the DP protocol.

Availability

All CPUs with DP interface(s) and serving as DP masters feature the enhanced DPV1 functionality.

Note

If you want to use the CPU as an intelligent slave, remember that it does not have DPV1 functionality.

Requirement for using the DPV1 functionality with DP slaves

For DPV1 slaves from other vendors, you will need a GSD file conforming to EN 50170, revision 3 or later.

Extended functions of DPV1

- Use of any DPV1 slaves from external vendors (in addition to the existing DPV0 and S7 slaves, of course).
- Selective handling of DPV1-specific interrupt events by new interrupt blocks.
- Reading/writing SFBs that conform to standards to the data record (although this can only be used for centralized modules).
- User-friendly SFB for reading diagnostics.

Interrupt blocks with DPV1 functionality

Table 4-6 Interrupt blocks with DPV1 functionality

| OB | Functionality |
|-------|---------------------------|
| OB 40 | Process interrupt |
| OB 55 | Status interrupt |
| OB 56 | Update interrupt |
| OB 57 | Vendor-specific interrupt |
| OB 82 | Diagnostic interrupt |

Note

You can now also use organizational blocks OB40 and OB82 for DPV1 interrupts.

System blocks with DPV1 functionality

Table 4-7 System function blocks with DPV1 functionality

| SFB | Functionality |
|--------|--|
| SFB 52 | Read data record from DP slave/IO device or centralized module |
| SFB 53 | Write data record to DP slave/IO device or centralized module |
| SFB 54 | Read additional alarm information from a DP slave/IO device or a centralized module in the relevant OB |
| SFB 75 | Send alarm to the DP master |

Note

You can also use SFB 52 to SFB 54 for centralized I/O modules.

Reference

For further information on the blocks mentioned earlier, refer to the reference manual *System Software for S7-300/400: System and Standard Software*, or directly to the *STEP 7 Online Help*.

Memory concept

5.1 Memory areas and retentive address areas

5.1.1 Technology CPU memory areas

Introduction

The memory of the Technology CPU is divided into three areas:

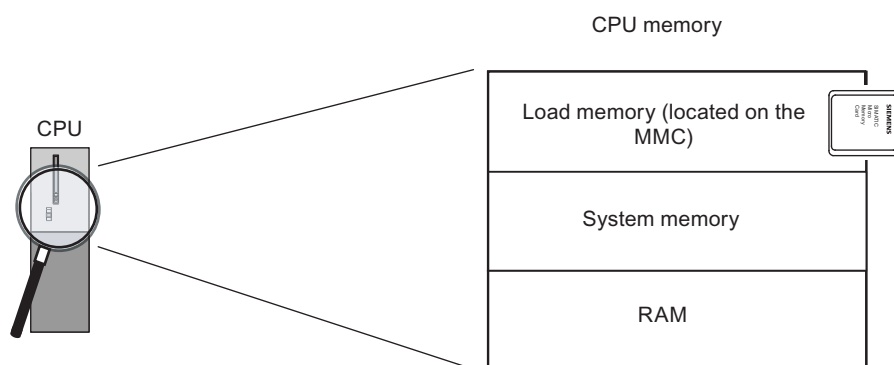

Figure 5-1 Technology CPU memory areas

Load memory

The load memory is located on the SIMATIC micro memory card (MMC). It is used to store code blocks, data blocks and system data (configuration, connections, module parameters, technology system data etc.).

For the Technology CPU, the size of the load memory corresponds to the size of the SIMATIC MMC minus approx. 3 MB. The 3 MB are required for the integrated technology and are therefore not available to the user.

Blocks that are identified as not relevant for the execution are stored exclusively in the load memory.

You can also store all the configuration data for your project on the SIMATIC Micro Memory Card.

 **CAUTION**

Downloading user programs and hence operating the CPU is only possible if a SIMATIC MMC is inserted.

If you pull out the SIMATIC MMC while the CPU is in RUN mode, the CPU then goes into STOP mode and the drives are shut down in accordance with your programming in the *STEP 7* user program.

This is why you should only remove the SIMATIC Micro Memory Card when the CPU is in STOP.

Work memory

The work memory is integrated in the CPU and cannot be extended. It is used to run the code and process user program data. Programs only run in the work memory and system memory. The work memory is always retentive.

System memory

The system memory is integrated in the CPU and cannot be expanded.

It contains

- the operand areas for flags, times and counters
- the process image of the inputs and outputs
- the local data

5.1.2 Retentive address areas of the load memory, system memory and technology system data

Introduction

Your CPU is equipped with a maintenance-free retentive memory, i.e., its operation does not require a buffer battery. The retentivity is realized via the SIMATIC Micro Memory Card. Data is also retained in the retentive memory throughout POWER OFF and restart (warm restart).

Retentive data in load memory

Your program in the load memory is always retentive: it is already stored on the SIMATIC Micro Memory Card, where it is protected against power failure or memory restart.

Retentive data in system memory

In your configuration (Properties of CPU, Retentive address areas tab), specify which parts of the tags, timers and counters should be retentive and which of them are to be initialized with "0" on restart (warm restart).

The diagnostics buffer, MPI address (and transmission rate) and operating hour counter data are generally written to the retentive memory area on the CPU. Retentivity of the MPI address and baud rate ensures that your CPU can continue to communicate, even after a power loss, memory reset or loss of communication parameters (e.g. due to removal of the SIMATIC Micro Memory Card or deletion of communication parameters).

Retentive data in the work memory

Therefore, the contents of retentive DBs are always retentive at restart and POWER ON/OFF. Retentive data blocks can be uploaded to the work memory in accordance with the maximum limit allowed by the work memory.

In the case of the Technology CPU, non-retentive DBs are also supported. Non-retentive DBs are initialized from the load memory with their initial values whenever a restart is performed or when the power is switched off and then on again. Non-retentive data blocks and code blocks can be loaded in accordance with the maximum work memory limit.

Technology system data

The technology system data are always stored as retentive data in the load memory of the CPU.

5.1.3 Retentivity of memory objects

Retentive behavior of the memory objects

The table below shows the retentive behavior of memory objects during specific operating state transitions.

Table 5-1 Retentive behavior of the memory objects

| Memory object | Operating state transition | | |
|---|--|---------------|---------------------|
| | POWER ON / POWER OFF | STOP → RUN | CPU memory reset |
| User program/data (load memory) | X | X | X |
| <ul style="list-style-type: none"> • Retentive behavior of the DBs (without technology DB) • Retentive behavior of the technology DBs | Can be set in the Properties of the DBs. | | - |
| | - | - | - |
| Flags, timers and counters configured as retentive data | X | X | - |
| Diagnostics buffer, operating hour counters | X | X | X |
| MPI/DP address, transmission rate (or also DP address, transmission rate of the Technology CPU MPI/DPinterface, if this is parameterized as DP node). | X | X | X |
| Technological parameters <ul style="list-style-type: none"> • Changed with FB "MC_WriteParameter" • Changed with <i>S7TConfig</i> | - | X | - |
| | X | X | X |

x = retentive; - = non-retentive

Retentive behavior of a DB

These CPUs support the generation of data blocks with "NON-Retain" (not retentive) property. Data blocks assigned the "NON-Retain" property are initialized with their start values when power is cycled off and on and when the CPU goes from STOP to RUN. You have two options of assigning the "NON-Retain" property to a DB:

- STEP 7, V5.2 + SP1 or higher: Activate the NON-Retain function in the DB properties
- SFC 82 "Crea_DBL" (generation of a DB in load memory): Set bit 2 = "1" at the ATTRIB parameter

Table 5-2 Retentive behavior of the DBs for the Technology CPU

| At POWER ON/OFF or restart of the CPU, the DB should ... | |
|--|--|
| ... receive the initial values (non-retentive DB) | ... retain the last actual values (retentive DB) |
| Reason: At POWER ON/OFF and restart (STOP-RUN) of the CPU, the actual values of the DB are non-retentive. The DB receives the initial values from the load memory. | Reason: At POWER OFF/ON and restart (STOP-RUN) of the CPU, the actual values of the DB are retained. |
| Condition in STEP 7: <ul style="list-style-type: none"> • The "Non-retain" check box must be activated in the block properties of the DB, or • a non-retentive DB was generated with SFC 82 "CREA_DBL" and the associated block attribute (ATTRIB -> NON_RETAIN bit). | Condition in STEP 7: <ul style="list-style-type: none"> • The "Non-retain" check box must be deactivated in the block properties of the DB, or • a retentive DB was generated with SFC 82. |

Retentive behavior of a technology data block

Technology data blocks are non-retentive.

5.1.4 Address areas of system memory

Overview

The system memory of the S7 CPUs is organized in address areas (refer to the table below). In a corresponding operation of your user program, you address data directly in the relevant address area.

Table 5-3 Address areas of system memory

| Operand areas | Description |
|----------------------|---|
| Process input image | At every start of an OB1 cycle, the CPU reads the values at the input of the input modules and saves them the process input image. |
| Process output image | During its cycle, the program calculates the values for the outputs and writes these to the process output image. At the end of the OB1 cycle, the CPU writes the calculated output values to the output modules. |
| Flag | This area provides memory for saving the intermediate results of a program calculation. |
| Times | Timers are available in this area. |
| Counters | Counters are available in this area. |
| Local data | Temporary data in a code block (OB, FB, FC) is saved to this memory area while the block is being edited. |
| Data blocks | See <i>recipes</i> , <i>measurement value logs</i> and <i>technology data blocks</i> . |

Reference

The address areas of your CPU are listed in the *Instruction list for CPUs 31xC and 31x*.

Process image of inputs/outputs

When the user program addresses the input (I) and output (O) address areas, it does not query the signal states of digital signal modules. Instead, it rather accesses a memory area in CPU system memory. This particular memory area is the process image.

The process image is organized in two sections: The process input image, and the process output image.

Advantages of the process image

Process image access, compared to direct I/O access, offers the advantage that a consistent image of process signals is made available to the CPU during cyclic program execution. When the signal status at an input module changes during program execution, the signal status in the process image is maintained until the image is updated in the next cycle. Moreover, since the process image is stored in CPU system memory, access is significantly faster than direct access to the signal modules.

Process image update

The operating system updates the process image periodically. The figure below shows the sequence of this operation within a cycle.

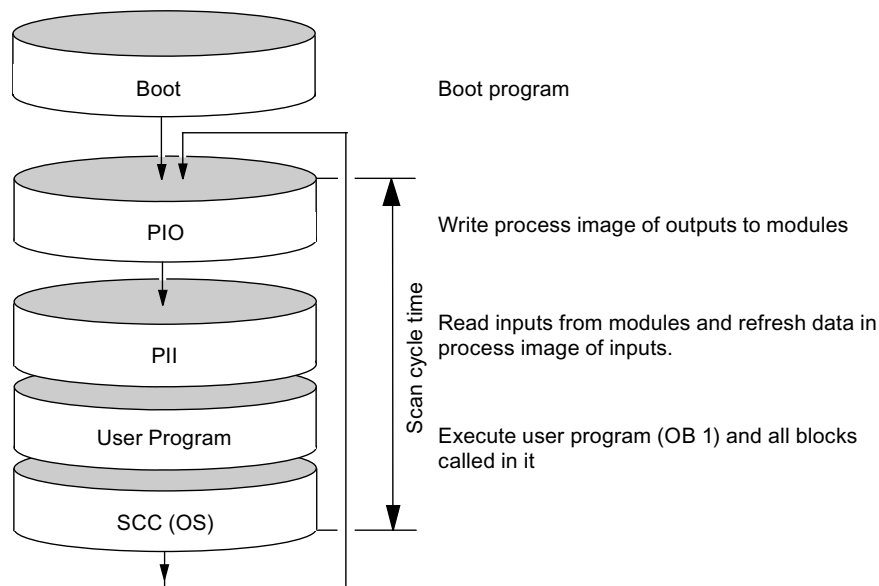

Figure 5-2 Sequence of operation within a cycle

Configurable process image of the CPUs

STEP 7 lets you define a user-specific size of the process image of the inputs/outputs between 0 to 2048 for the following CPUs:

| CPU | Firmware |
|---------------|----------------|
| CPU 315T-2 DP | V2.6 or higher |
| CPU 317T-2 DP | V2.6 or higher |

Note the information below:

Note

Currently, the dynamic setting of the process image only affects its update at the scan cycle control point. That is, the process input image is only updated up to the set PII size with the corresponding values of the peripheral input modules existing within this address area, or the values of the process output image up to the set POI size are written to the peripheral output modules existing within this address area.

This set size of the process image is ignored with respect to STEP 7 commands used to access the process image (for example U I100.0, L EW200, = Q20.0, T AD150, or corresponding indirect addressing commands also). However, up to the maximum size of the process image (that is, up to I/O byte 2047), these commands do not return any synchronous access errors, but rather access the permanently available internal memory area of the process image.

The same applies to the use of actual parameters of block calls from the I/O area (area of the process image).

Particularly if these process image limits were changed, you should check to which extent your user program accesses the process image in the area between the set and the maximum process image size. If access to this area continues the user program may not detect changes at the inputs of the I/O module, or actually fails to write output data to the output module and does not generate an error message.

You should also note that certain CPs may only be addressed outside of the process image.

Local data

Local data store:

- the temporary variables of code blocks
- the start information of the OBs
- transfer parameters
- intermediate results

Temporary Variables

When you create blocks, you can declare temporary variables (TEMP) which are only available during block execution and then overwritten again. These local data have fixed length in each OB. Local data must be initialized prior to the first read access. Each OB also requires 20 bytes of local data for its start information. Local data access is faster compared to access to data in DBs.

The CPU is equipped with memory for storing temporary variables (local data) of currently executed blocks. The size of this memory area depends on the CPU. It is distributed in partitions of equal size to the priority classes. Each priority class has its own local data area.

CAUTION

All temporary variables (TEMP) of an OB and its nested blocks are stored in local data. When using complex nesting levels for block processing, you may cause an overflow in the local data area.

The CPUs will change to STOP mode if you exceed the permissible length of local data for a priority class.

Make allowances for local data space required for synchronous error OBs. This is assigned to the respective triggering priority class.

5.1.5 Properties of the SIMATIC Micro Memory Card

The SIMATIC Micro Memory Card as memory module for the CPU

The memory module used on your CPU is a SIMATIC Micro Memory Card. It can be used as load memory or as a portable storage medium.

Note

The CPU requires the SIMATIC Micro Memory Card for operation.

What is stored on the SIMATIC Micro Memory Card

The following data can be stored on the SIMATIC Micro Memory Card:

- User program, i.e., all blocks (OBs, FCs, FCs, DBs) and system data
- Archives and recipes
- Configuration data (STEP 7 projects)
- Data for operating system update and backup

Note

You can either store user and configuration data or the operating system on the SIMATIC Micro Memory Card.

Properties of a SIMATIC Micro Memory Card

The SIMATIC Micro Memory Card ensures maintenance-free and retentive operation of these CPUs.

| |
|--|
|  CAUTION |
|--|

| |
|---|
| Data on a SIMATIC Micro Memory Card can be corrupted if you remove the card while it is being accessed by a write operation. In this case, you may have to delete the SIMATIC Micro Memory Card on your programming device, or format the card in the CPU. Never remove a SIMATIC Micro Memory Card in RUN mode. Always remove it when power is off, or when the CPU is in STOP state, and when the programming device is not writing to the card. If the CPU is in STOP mode and you cannot determine whether or not a programming device function is active (e.g. load/delete block), disconnect the communication lines. |
|---|

SIMATIC Micro Memory Card copy protection

Your SIMATIC Micro Memory Card has an internal serial number that implements an MMC copy protection. You can read this serial number from the SSL partial list 011C_H index 8 using SFC 51 "RDSYSST." If the reference and actual serial number of your SIMATIC Micro Memory Card are not the same, program a STOP command in a know-how-protected module, for example.

Service life of a SIMATIC Micro Memory Card

The service life of a SIMATIC Micro Memory Card essentially depends on the following factors:

- The number of delete or programming operations,
- external influences such as the ambient temperature.

At ambient temperatures up to 60 °C, a maximum of 100,000 delete/write operations can be performed on a SIMATIC Micro Memory Card.

| |
|--|
|  CAUTION |
|--|

| |
|---|
| In order to prevent data losses, do not exceed this maximum of delete/write operations. |
|---|

Reference

Further information:

- on the *SSL parts list*, refer to the *CPU 31xC and CPU 31x Instruction List*, or to the *S7-300/400 System Software, System and Standard Functions Reference Manual*.
- on resetting the CPU, refer to the *Operating Instructions CPU 31xC and CPU31x, Commissioning, Commissioning Modules, CPU Memory Reset by means of Mode Selector Switch*

5.2 Memory functions

5.2.1 General: Memory functions

Memory functions

Memory functions are used to generate, modify or delete entire user programs or specific blocks. You can also ensure that your project data are retained by archiving these. If you created a new user program, use a programming device / PC to download the complete program to the SIMATIC Micro Memory Card.

5.2.2 Load user program from SIMATIC Micro Memory Card to the CPU

User program download

The entire user program data are downloaded from your programming device / PC to the CPU by means of the SIMATIC Micro Memory Card. The previous content of the Micro Memory Card is deleted in the process. Blocks use the load memory area as specified under "Load memory requirements" in "General block properties".

The figure shows the load and work memory of the CPU

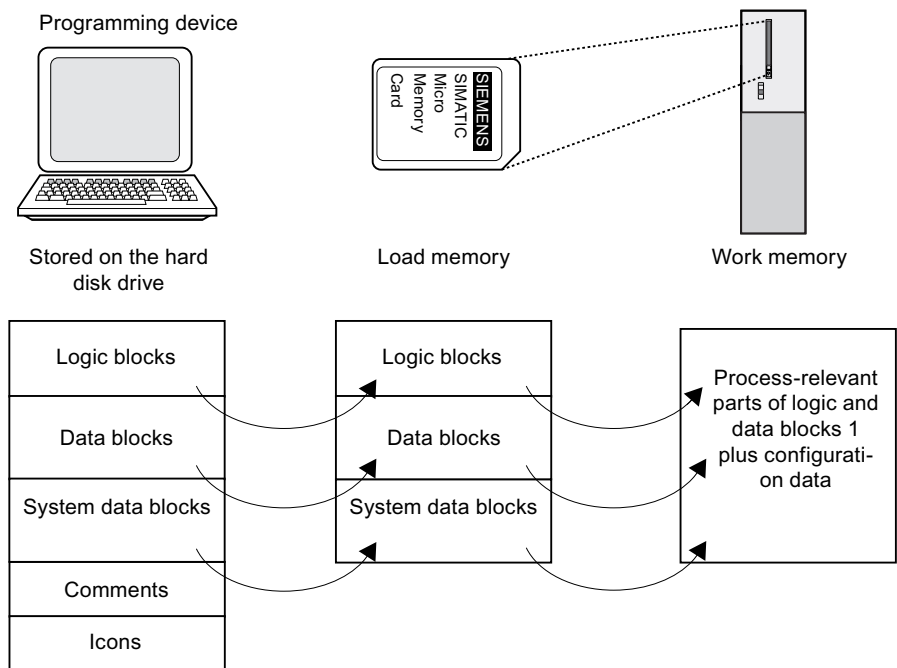

¹: If not all of the work memory area is retentive, the retentive area is indicated in STEP 7 module status as retentive memory. You cannot run the program until all the blocks are downloaded.

Note

This function is only permitted when the CPU is in STOP mode. Load memory is cleared if the load operation could not be completed due to power loss or illegal block data.

5.2.3 Handling blocks

5.2.3.1 Downloading new blocks or delta downloads

There are two ways to download additional user blocks or download deltas:

- Download of blocks: You already created a user program and downloaded it to the CPU via the SIMATIC Micro Memory Card. You then want to add new blocks to the user program. In this case you do not need to reload the entire user program to the MCC. Instead you only need to download the new blocks to the SIMATIC Micro Memory Card (this reduces the download times for highly complex programs.)
- Delta download: In this case, you only download the deltas in the blocks of your user program. In the next step, perform a delta download of the user program, or only of the changed blocks to the SIMATIC Micro Memory Card, using the PG/PC.

| |
|--|
|  WARNING |
|--|

| |
|--|
| The delta down of block / user programs overwrites all data stored under the same name on the SIMATIC Micro Memory Card. |
|--|

The data of dynamic blocks are transferred to RAM and activated after the block is downloaded.

5.2.3.2 Uploading blocks

Uploading blocks

Unlike download operations, an upload operation is the transfer of specific blocks or a complete user program from the CPU to the PG/PC. The block content is here identical with that of the last download to the CPU. Dynamic DBs form the exception, because their actual values are transferred. An upload of blocks or of the user program from the CPU in STEP 7 does not influence CPU memory.

5.2.3.3 Deleting blocks

Deleting blocks

When you delete a block, it is deleted from load memory. In STEP 7, you can also delete blocks with the user program (DBs also with SFC 23 "DEL_DB"). RAM used by this block is released.

5.2.3.4 Compressing blocks

Compressing blocks

When data are compressed, gaps which have developed between memory objects in load memory/RAM as a result of load/delete operations will be eliminated. This releases free memory in a continuous block. Data compression is possible when the CPU is in RUN or in STOP.

5.2.3.5 Promming (RAM to ROM)

Promming (RAM to ROM)

When writing the RAM content to ROM, the actual values of the DBs are transferred from RAM to load memory to form the start values for the DBs.

Note

This function is only permitted when the CPU is in STOP mode. Load memory is cleared if the function could not be completed due to power loss.

5.2.4 CPU memory reset and restart

CPU memory reset

After the insertion/removal of a Micro Memory Card, a CPU memory reset restores defined conditions for CPU restart (warm start).

Technology CPU:

- The CPU's memory management is rebuilt.
- Blocks in load memory are retained.
- All runtime-related blocks are transferred from the load memory to the work memory again.
- The data blocks in the work memory are initialized (are thus reset to their initial values).

Integrated technology of Technology CPU:

The CPU waits until the integrated technology has reached the STOP state.

- The integrated technology is parameterized again.
- The retentive memory of the integrated technology is rebuilt.
- Any distributed I/Os connected to DP(DRIVE) are parameterized again.
- The integrated technology is initialized again.

Reference

Also refer to CPU memory reset by means mode selector switch in the Commissioning section in the CPU 31xC and CPU 31x Operating Instructions.

Warm Restart

What happens during a warm restart:

- All retentive DBs retain their current values.
- Non-retentive DBs are reset to their initial values.
- The values of all retentive M, C, T are retained.
- All non-retentive user data are initialized:
 - M, C, T, I, O with "0"
- All run levels are initialized.
- The process images are deleted.

5.2.5 Backup of project data to SIMATIC Micro Memory Card

Function principle

Using the **Save to Memory Card** and **Retrieve from Memory Card** functions, you can save all project data to a SIMATIC Micro Memory Card, and retrieve these at a later time. For this operation, the SIMATIC Micro Memory Card can be located in a CPU or in the MMC adapter of a PG or PC.

Project data are compressed before they are saved to a SIMATIC Micro Memory Card, and uncompressed when retrieved.

The volume of project data to be saved corresponds with the size of the project's archive file.

Note

In addition to project data, you may also have to store your user data on the MMC. You must therefore make sure beforehand that you select an MMC with sufficient memory capacity.

A message warns you if the memory capacity on your SIMATIC Micro Memory Card is insufficient

Even though you can load technology configuration data from the Micro Memory Card, you cannot edit the data.

For technical reasons, you can only transfer the entire contents (user program and project data) using the **Save to memory card** action.

5.3 Recipes

Introduction

A recipe represents a collection of user data. You can implement a simple recipe concept using static DBs. In this case, the recipes should have the same structure (length). One DB should exist per recipe.

Processing sequence

Recipe is written to load memory:

The various data records of recipes are created as static DBs in STEP 7 and then downloaded to the CPU. Therefore, recipes only use load memory, rather than the work memory.

Working with recipe data:

SFC83 "READ_DBL" is called in the user program to copy the data record of a current recipe from the DB in load memory to a static DB that is located in work memory. As a result, the work memory only has to accommodate the data of one record. The user program can now access data of the current recipe. The figure below shows how to handle recipe data:

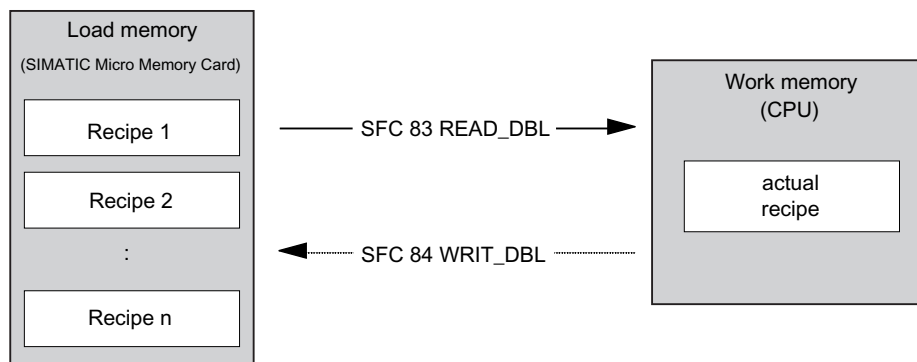

Figure 5-3 Handling recipes

Saving a modified recipe:

The data of new or modified recipe data records generated during program execution can be written to load memory. To do this, call SFC 84 "WRIT_DBL" in the user program. The data written to load memory are portable and retentive on Memory reset. You can backup modified records (recipes) by uploading and saving these in a single block to the PG/PC.

Note

Active system functions SFC82 to 84 (active access to the SIMATIC Micro Memory Card) have a distinct influence on programming device functions (for example, block status, variable status, download block, upload, open.) This typically reduces performance (compared to passive system functions) by a factor of 10.

Note

In order to prevent data losses, do not exceed this maximum of delete/write operations. Also refer to the SIMATIC Micro Memory Card (MMC) section in the "Configuration and Communication Connections of a CPU" chapter.

CAUTION

Data on a SIMATIC Micro Memory Card can be corrupted if you remove the card while it is being accessed by a write operation. In this case, you may have to delete the SIMATIC Micro Memory Card on your programming device, or format the card in the CPU. Never remove a SIMATIC Micro Memory Card in RUN mode. Always remove it when power is off, or when the CPU is in STOP state, and when the programming device is not writing to the card. If the CPU is in STOP mode and you cannot determine whether or not a programming device function is active (e.g. load/delete block), disconnect the communication lines.

5.4 Measured value log files

Introduction

Measured values are generated when the CPU executes the user program. These values are to be logged and analyzed.

Processing sequence

Acquisition of measured values:

The CPU writes all measured values to a DB (for alternating backup mode in several DBs) which is located in the work memory.

Measured value logging:

- Before the data volume can exceed work memory capacity, you should call SFC 84 "WRIT_DBL" in the user program to swap measured values from the DB to load memory. The figure below shows how to handle measured value log files:

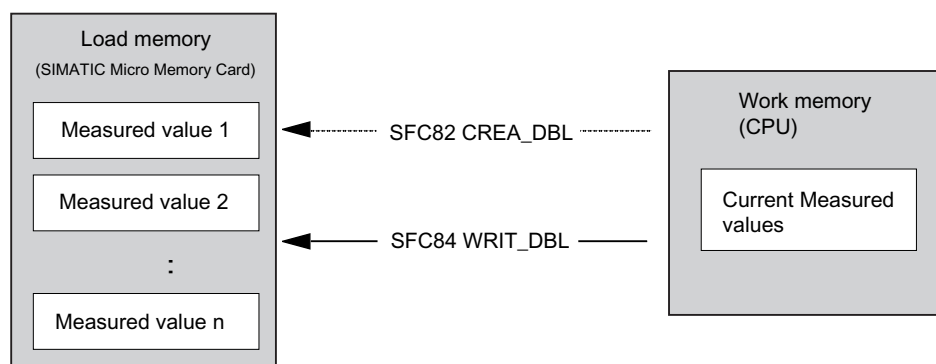

- You can call SFC 82 "CREA_DBL" in the user program to generate new (additional) static DBs in load memory which do not require work memory space.

Reference

For detailed information on SFC 82, refer to the *System Software for S7-300/400, System and Standard Functions Reference Manual*, or directly to the STEP 7 Online Help.

Note

SFC 82 is terminated and an error message is generated if a DB already exists under the same number in load memory and/or work memory.

The data written to load memory are portable and retentive on Memory reset.

Evaluation of measured values:

Measured value DBs saved to load memory can be uploaded and evaluated by other communication partners (PG, PC, for example).

Note

Active system functions SFC82 to 84 (active access to the SIMATIC Micro Memory Card) have a distinct influence on programming device functions (for example, block status, variable status, download block, upload, open.) This typically reduces performance (compared to passive system functions) by a factor of 10.

Note

For CPUs with firmware V2.0.12 or higher, you can also generate non-retentive DBs using SFC 82 (parameter ATTRIB -> NON_RETAIN bit.)

Note

In order to prevent data losses, do not exceed this maximum of delete/write operations. For further information, refer to the Technical Data of the SIMATIC Micro Memory in the General Technical Data of your CPU.

CAUTION

Data on a SIMATIC Micro Memory Card can be corrupted if you remove the card while it is being accessed by a write operation. In this case, you may have to delete the SIMATIC Micro Memory Card on your programming device, or format the card in the CPU. Never remove a SIMATIC Micro Memory Card in RUN mode. Always remove it when power is off, or when the CPU is in STOP state, and when the programming device is not writing to the card. If the CPU is in STOP mode and you cannot determine whether or not a programming device function is active (e.g. load/delete block), disconnect the communication lines.

5.5 Technology data blocks

Introduction

The integrated technology of the Technology CPU provides current information on the status and on the values of the technology objects via the technology data blocks. To achieve especially short response times, the technology data blocks can be evaluated in OB 65.

Processing sequence

When technology objects are configured, *S7-Technology* creates data blocks in the block folder.

If you initiate jobs to drives using a technology function, you read the states and values in the associated technology data block. A job is active if the block signals busy.

The CPU can execute a maximum of 210 active jobs simultaneously.

The following technology functions occupy additional memory space:

- MC_ReadPeriphery
- MC_WritePeriphery
- MC_ReadRecord
- MC_WriteRecord
- MC_ReadDriveParameter
- MC_WriteDriveParameter
- MC_CamSectorAdd
- MC_ReadCamTrackData
- MC_WriteCamTrackData

The maximum number of job data compartments occupied simultaneously is limited to 100.

Reference

For further information, refer to the *S7-Technology* manual.

5.6 Memory of the integrated technology of the CPU

Memory utilization

The following table contains typical values for the memory utilization in the integrated technology. The values refer to a Technology CPU with firmware Version of the integrated technology of V4.1 of higher:

| | CPU 315T-2 DP (6ES7 315-6TH13-0AB0) as of E version 01 | CPU 317T-2 DP (6ES7 317-6TK13-0AB0) as of E version 01 |
|--|--|--|
| Base load of the integrated technology | 25 % | 15 % |
| Speed-controlled axis | 1,25 % | 0,75 % |
| Positioning axis | 1,5 % | 0,9 % |
| Following axis (with one following object) | 2,5 % | 1,5 % |
| Following axis (with two following objects) | 3,5 % | 2 % |
| External encoders | 0,6 % | 0,35 % |
| Output cams | 0,25 % | 0,15 % |
| Cam track as of S7 Technology V4.1 | 2,8 % | 1,5 % |
| Measuring input | 0,25 % | 0,15 % |
| Cam (empty) | 0,25 % | 0,15 % |
| Cam interpolation points* | 0,0046 % | 0,0008 % |
| Cam interpolation points to be interpolated* | 0,0027 % | 0,0016 % |
| Maximum memory utilization | | |
| Recommended | 80 % | 80 % |

* Further explanations can be found in the following calculation example.

Note

With insufficient memory, the Technology CPU goes into STOP mode. Note that these listed values are only typical values and some commands may temporarily require more memory during runtime.

If the memory utilization is excessive, online monitoring from S7T Config may no longer be possible.

Therefore, the recommended calculated maximum memory utilization should not be exceeded.

Calculation example

The table shows the memory utilization for a sample configuration with a CPU 315T-2 DP (6ES7 315-6TH13-0AB0) with hardware version 01. The maximum memory utilization is 77% and is therefore less than the recommended maximum memory utilization.

| Quantity | Description | Memory utilization | Memory utilization (total) |
|----------|---|--------------------|----------------------------|
| 1 | Base load of the integrated technology | 25 % | 25 % |
| 6 | Following axis (with one following object) | 2,5 % | 15 % |
| 2 | External encoder | 0,6 % | 1,2 % |
| 6 | Output cams | 0,25 % | 1,5 % |
| 2 | Measuring input | 0,25 % | 0,5 % |
| 14 | Cam (empty) | 0,25 % | 3,5 % |
| 6000* | Cam interpolation points | 0,0046 % | 27,6 % |
| 1000** | Cam interpolation points to be interpolated | 0,0027 % | 2,7 % |
| | Total | | 77 % |

* The maximum possible number of cam interpolation points must be taken into account as value in the Technology CPU. Example:

10 cams each with 300 cam interpolation points

2 cams each with 500 cam interpolation points

2 cams each with 1000 cam interpolation points

This is a total of 6000 cam interpolation points (10x300 + 2x500 + 2x1000).

** Additional memory is used during the interpolation of a cam. As only one cam can be interpolated at one time, in this case the cam with the largest number of cam interpolation points must be taken into account (this is 1000 cam interpolation points in the calculation example).

Reference

More detailed information on determining the actual memory assignment in the integrated technology can be found in the *S7-Technology* manual.

Retentive address areas of the memory of the CPU integrated technology

The values for the absolute encoder calibration are stored in a non-volatile memory in the integrated technology of the CPU.

With the technology function "MC_ReadSysParameter" you can read out the absolute encoder calibration values and store them retentively in a data block in the load memory on the SIMATIC MMC. If a CPU is replaced, you can write these stored values back to the integrated technology via the FB "MC_WriteParameter".

I/O image DP(DRIVE)

Part of the address areas of the DP(DRIVE) is listed in the integrated technology as I/O image DP(DRIVE). You can read this area in the user program with the technology function "MC_ReadPeriphery" and write with the technology function "MC_WritePeriphery".

The update of the I/O image DP(DRIVE) is described in the *S7-Technology* manual at the technology functions "MC_ReadPeriphery" and "MC_WritePeriphery".

Cycle and response times

6.1 Overview

Overview

This section contains detailed information about the following topics:

- Cycle time
- Response time
- Interrupt response time
- Sample calculations

Reference: Cycle time

You can view the cycle time of your user program on the PG.

Reference: Execution time

You can find information in the *S7-300 Instruction List for CPUs 31xC and 31x*. This tabular list contains the execution times for all

- *STEP 7* instructions the relevant CPUs can execute,
- the SFCs / SFBs integrated in the CPUs,
- the IEC functions which can be called in *STEP 7*.

Reference: Motion Control runtimes

You can find information about runtimes on PROFIBUS DP(DRIVE) in the *S7-Technology manual*.

6.2 Cycle time

6.2.1 Overview

Introduction

This chapter explains what we mean by the term "cycle time", what it consists of, and how you can calculate it.

Meaning of the term cycle time

The cycle time represents the time that an operating system needs to execute a program, that is, one OB 1 cycle, including all program sections and system activities interrupting this cycle.

This time is monitored.

Time-Sharing Model

Cyclic program processing, and therefore user program execution, is based on time shares. To clarify these processes, let us assume that every time share has a length of precisely 1 ms.

Process image

During cyclic program processing, the CPU requires a consistent image of the process signals. To ensure this, the process signals are read/written prior to program execution. Subsequently, the CPU does not address input (I) and output (Q) address areas directly at the signal modules, but rather accesses the system memory area containing the I/O process image.

Sequence of cyclic program processing

The table and figure below show the phases in cyclic program processing.

Table 6-1 Cyclic program processing

| Step | Operational sequence |
|------|---|
| 1 | The operating system initiates cycle time monitoring. |
| 2 | The CPU copies the values of the process output image to the output modules. |
| 3 | The CPU reads the status at the inputs of the input modules and then updates the process input image. |
| 4 | The CPU processes the user program in time shares and executes program instructions. |
| 5 | At the end of a cycle, the operating system executes pending tasks, such as the loading and clearing of blocks. |
| 6 | The CPU then returns to the start of the cycle, and restarts cycle time monitoring. |

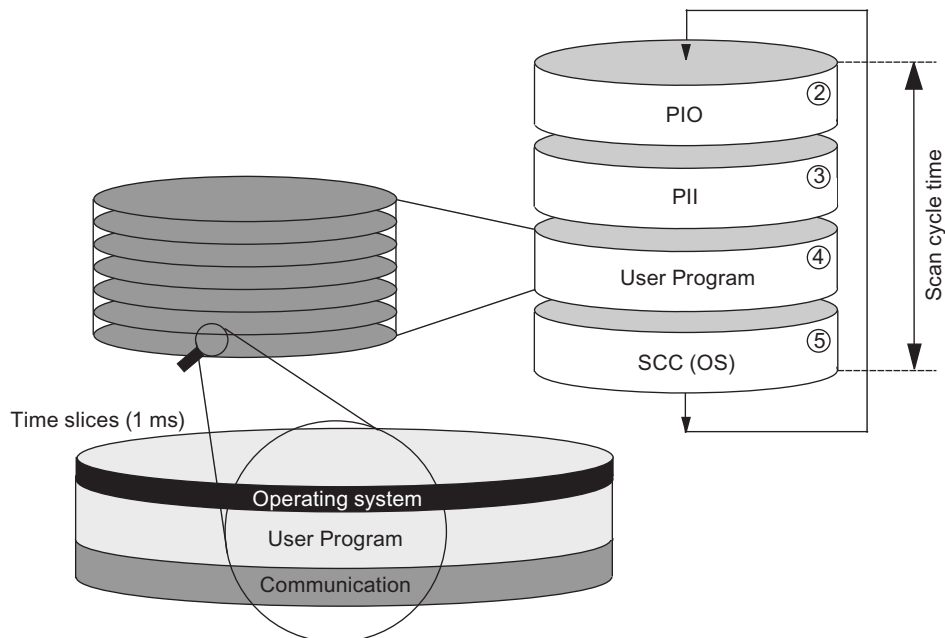

Figure 6-1 Time-Sharing Model

- PIO: Process output image
- PII: Process input image
- SCC: Scan cycle check point

In contrast to S7-400 CPUs (and the CPU 318-2 DP), the S7-300 CPUs data only allow data access from an OP / TD (monitor and modify functions) at the scan cycle check point (Data consistency, see the Technical Specifications). Processing of the user program is not interrupted by the monitor and modify functions.

Increasing the Cycle Time

Always make allowances for the extension of the cycle time of a user program due to:

- Time-based interrupt processing
- Process interrupt processing
- Diagnostics and error handling
- Communication with PGs, Operator Panels (OPs) and connected CPs (for example, Ethernet, PROFIBUS DP)
- Testing and commissioning such as, e.g. status/controlling of variables or block status functions.
- Transfer and deletion of blocks, compressing user program memory
- Describe, read the SIMATIC Micro Memory Card using SFC 82 to 84 in the user program

6.2.2 Calculating the cycle time

Introduction

The cycle time is derived from the sum of the following influencing factors.

Process image update

The table below shows the CPU times for the process image update (process image transfer time). The times specified might be prolonged as a result of interrupts or CPU communication.

The transfer time for the process image update is calculated as follows

Base load K
 + number of bytes in the PI in the rack 0 × (A)
 + number of bytes in the PI via DP × (D)
 = **transfer time for the process image**

Table 6-2 Data for calculating the process image (PI) transfer time

| Constant | Components | CPU 315T-2 DP | CPU 317T-2 DP |
|----------------|---|---------------|---------------|
| K | Base load | 100 µs | 50 µs |
| A | Per byte in the rack 0 | 37 µs | 15 µs |
| D (DP only) | Per WORD in the DP area for the integrated DP interface | 1 µs | 1 µs |

Extending the user program processing time

In addition to actually working through the user program, your CPU's operating system also runs a number of processes in parallel, such as timer management for the core operating system. These processes extend the processing time of the user program.

The table below lists the multiplication factors required to calculate your user program processing time.

Table 6-3 Extending the user program processing time

| CPU | Factor |
|---------------|--------|
| CPU 315T-2 DP | 1,10 |
| CPU 317T-2 DP | 1,07 |

Operating system processing time at the scan cycle checkpoint

The following table shows the operating system processing time at the cycle checkpoint of the CPUs. These times are calculated without taking into consideration times for:

- Testing and commissioning routines, e.g. status/controlling of variables or block status functions
- Transfer and deletion of blocks, compressing user program memory
- Communication
- Writing, reading of the SIMATIC Micro Memory Card with SFC 82 to 84

Table 6-4 Operating system processing time at the scan cycle checkpoint

| CPU | Cycle control in the cycle checkpoint |
|---------------|---------------------------------------|
| CPU 315T-2 DP | 500 μ s |
| CPU 317T-2 DP | 150 μ s |

Extension of the cycle time due to nested interrupts and due to errors

Enabled interrupts also extend cycle time. Details are found in the table below.

Table 6-5 Increase in cycle time by nesting interrupts

| CPU | Process interrupt | Diagnostic interrupt | Time-of-day interrupt | Time-delay interrupt | Cyclic interrupt |
|---------------|-------------------|----------------------|-----------------------|----------------------|------------------|
| CPU 315T-2 DP | 500 µs | 600 µs | 400 µs | 300 µs | 150 µs |
| CPU 317T-2 DP | 190 µs | 240 µs | 200 µs | 150 µs | 90 µs |

You have to add the program execution time at the interrupt level to this increase.

Table 6-6 Cycle time extension as a result of errors

| CPU | Programming error | I/O access errors |
|---------------|-------------------|-------------------|
| CPU 315T-2 DP | 400 µs | 400 µs |
| CPU 317T-2 DP | 100 µs | 100 µs |

You have to add the program execution time of the interrupt OB to this increase.

The times required for multiple nested interrupt/error OBs are added accordingly.

6.2.3 Different cycle times

Overview

The length of the cycle time (T_{cyc}) is not identical in each cycle. The following figure shows different cycle times, T_{cyc1} and T_{cyc2} . T_{cyc2} is longer than T_{cyc1} , because the cyclically scanned OB 1 is interrupted by a time-of-day interrupt OB (here, OB10).

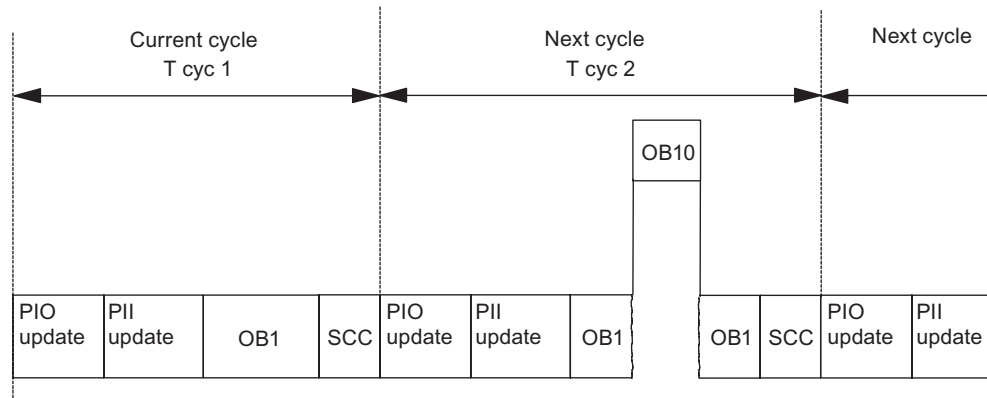

Figure 6-2 Different cycle times

Block processing times may fluctuate

Fluctuation of the block processing time (e.g. OB 1) may also be a factor causing cycle time fluctuation, due to:

- Conditional instructions,
- Conditional block calls,
- Different program paths,
- Loops, etc.

Maximum Cycle Time

In *STEP 7* you can modify the default maximum cycle time. If this time has expired, OB 80 is called, and in it you can define how you want the CPU to respond to the time error.

The CPU switches to STOP mode if OB80 does not exist in its memory.

6.2.4 Communication Load

Configured communication load (PG/OP communication)

The CPU operating system continuously provides a specified percentage of total CPU processing performance (time-sharing technology) for communication tasks. Processing performance not required for communication is made available to other processes.

In the hardware configuration, you can set the load due to communications between 5% and 50%. Default value is 20%.

You can use the following formula for calculating the cycle time extension factor:

$$100 / (100 - \text{configured communication load in \%})$$

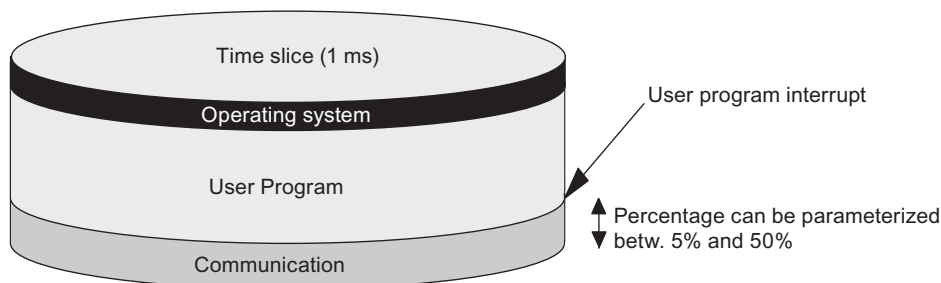

Figure 6-3 Breakdown of a time slice

Example: 20% communication load

You have configured a communication load of 20% in the hardware configuration.

The calculated cycle time is 10 ms.

Using the above formula, the cycle time is extended by the factor 1.25.

Example: 50 % communication load

You have configured a communication load of 50 % in the hardware configuration.

The calculated cycle time is 10 ms.

Using the above formula, the cycle time is extended by the factor 2.

Physical cycle time depending on communication load

The figure below describes the non-linear dependency of the physical cycle time on communication load. As an example, we have chosen a cycle time of 10 ms.

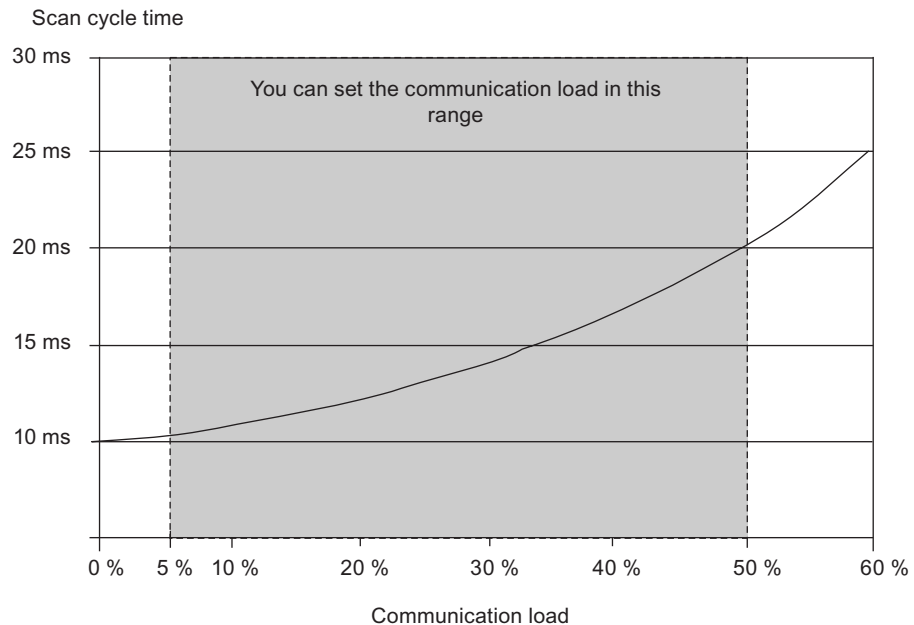

Figure 6-4 Dependency of the Cycle Time on the Communication Load

Influence on the physical cycle time

Due to the increase in the cycle time as a result of the communications component, even more asynchronous events occur, from a statistical point of view, within an OB 1 cycle than, say, interrupts. This further extends the OB1 cycle. This extension depends on the number of events that occur per OB1 cycle and the time required to process these events.

Note

Change the value of the "communication load" parameter to check the effects on the cycle time at system runtime. You must consider the communication load when you set the maximum cycle time, otherwise timing errors may occur.

Tips

- If possible, apply the default value.
- Increase this value only if the CPU is used primarily for communications and if the user program is not time critical.
- In all other situations you should only reduce this value.

6.2.5 Cycle time extension as a result of testing and commissioning functions

Technology CPU runtimes

The runtimes of the testing and commissioning functions are operating system runtimes, so they are the same for every CPU. Initially, there is no difference between process mode and testing mode.

How the cycle time is extended as a result of active testing and commissioning functions is shown in the table below.

Table 6-7 Cycle time extension as a result of testing and commissioning functions

| Function | Technology-CPU |
|------------------|--------------------------------|
| Status variable | 50 µs for each variable |
| Control variable | 50 µs for each variable |
| Block status | 200 µs for each monitored line |

Configuration during parameter assignment

For **Process Operation**, the maximum permissible cycle load by communication is not specified in "Cycle load by communication", but rather in "Maximum permitted increase of cycle time as a result of testing functions during process operation". Thus, the configured time is monitored absolutely in process mode and data acquisition is stopped if a timeout occurs. This is how *STEP 7* stops data requests in loops before a loop ends, for example.

When running in **Testing Operation**, the complete loop is executed in every cycle. This can significantly increase cycle time.

6.3 Response time

6.3.1 Overview

Definition of Response Time

The response time is the time from an input signal being detected to changing an output signal linked to it.

Variation

The actual response time lies somewhere between a minimum and maximum response time. For configuring your system, you must always reckon with the longest reaction time.

The shortest and longest response times are analyzed below so that you can gain an impression of the variation of the reaction time.

Factors

The reaction time depends on the cycle time and on the following factors:

- Delay of the inputs and outputs of signal modules or integrated I/O.
- Additional DP cycle times on the PROFIBUS DP network
- Execution of the user program

Reference

Further information

- about delay times can be found in the Technical Specifications of the signal modules (*Module data Reference Manual*).
- about delay times for the integrated inputs and outputs can be found in chapter *Technical Specifications of Integrated Technology Inputs and Outputs*

DP Cycle Times on the PROFIBUS-DP Network

If you have configured your PROFIBUS DP network with *STEP 7*, then *STEP 7* will calculate the typical DP cycle time that must be expected. You can then view the DP cycle time of your configuration on the PG.

The figure below gives you an overview of the DP cycle time. We assume in this example that each DP slave has 4 bytes of data on average.

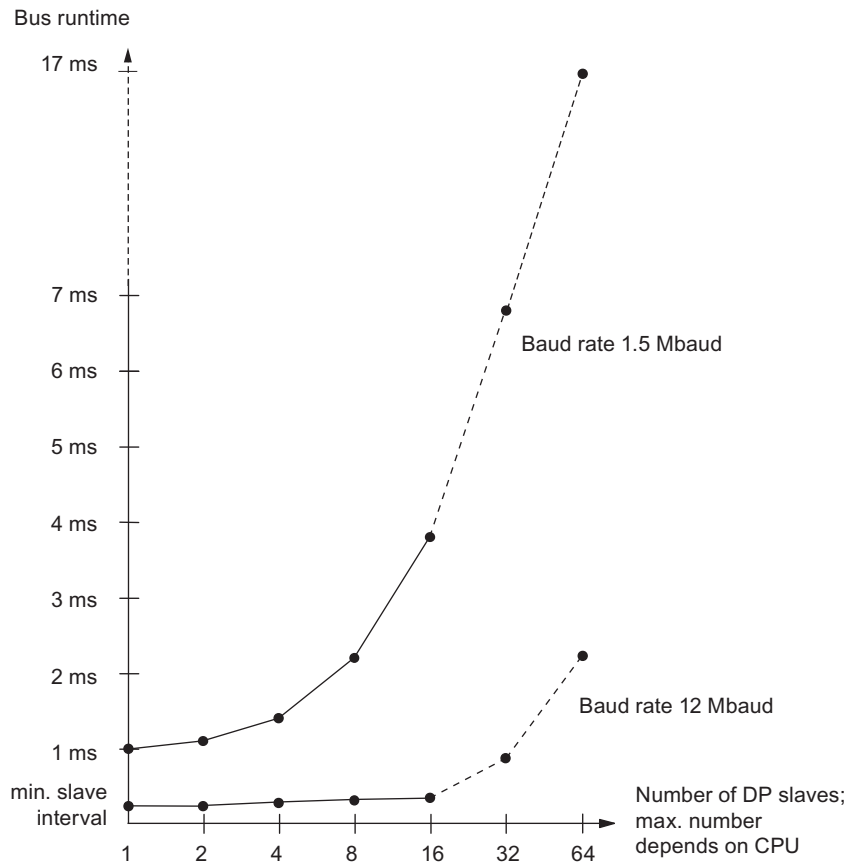

Figure 6-5 DP Cycle Times on the PROFIBUS-DP Network

With multi-master operation on a PROFIBUS-DP network, you must make allowances for the DP cycle time at each master. That is, you will have to calculate the times for each master separately and then add up the results.

6.3.2 Shortest response time

Conditions for the shortest response time

The following figure illustrates the conditions under which the shortest response time can be achieved.

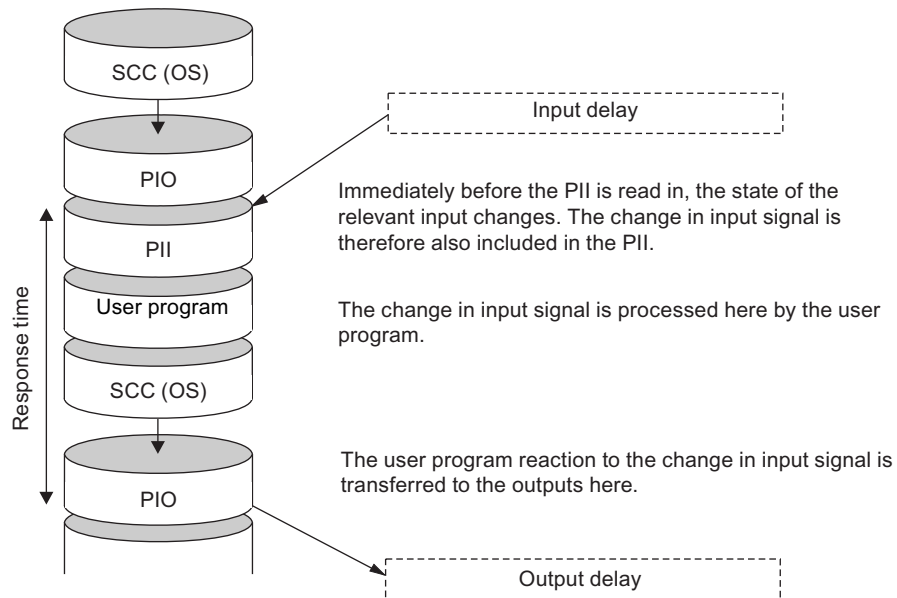

Figure 6-6 Shortest response time

Calculation

The (shortest) reaction time is made up as follows:

- 1 x process image transfer time for the inputs +
- 1 x process image transfer time for the outputs +
- 1 x program processing time +
- 1 x operating system processing time at the SCC +
- Delay in the inputs and outputs

The result is equivalent to the sum of the cycle time plus the I/O delay times.

6.3.3 Longest response time

Conditions for the longest response time

The following figure shows you how the longest response time results.

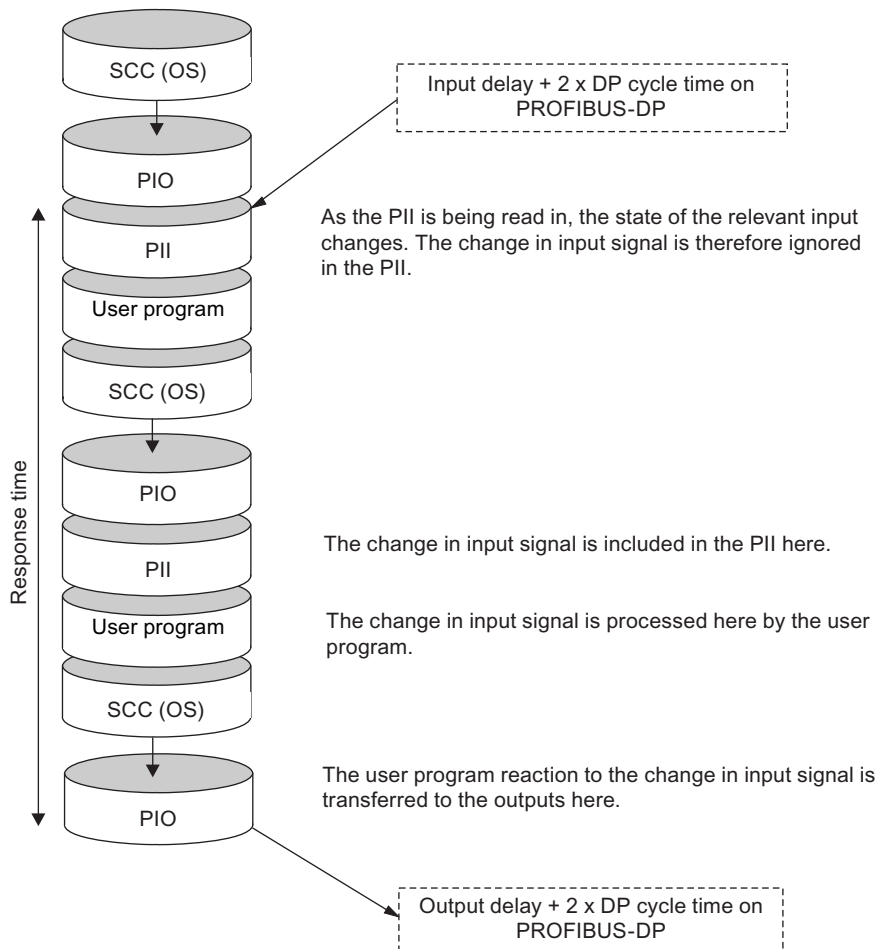

Figure 6-7 Longest response time

Calculation

The (longest) response time is made up as follows:

- 2 x process image transfer time for the inputs +
- 2 x process image transfer time for the outputs +
- 2 x program processing time +
- 2 x operating system processing time at the SCC +
- 4 x runtime of the DP slave frame (including processing in the DP master) +
- Delay in the inputs and outputs

This is equivalent to the sum of twice the cycle time and the delay in the inputs and outputs plus four times the DP cycle time.

6.3.4 Reducing the response time with direct I/O access

Reducing the Response Time

You can reach faster response times with direct access to the I/O in your user program, e.g. with

- L PIB or
- T PQW

you can partially avoid the response times described above.

Note

You can also achieve fast response times by using process interrupts (see next chapter).

6.4 Calculating method for calculating the cycle/response time

Introduction

This section gives you an overview of how to calculate the cycle/response time.

Cycle time

1. Determine the user program runtime with the help of the instruction list.
2. Multiply the calculated value by the CPU-specific factor from the table *Extension of user program processing time*.
3. Calculate and add the process image transfer time. Corresponding guide values are found in table *Data for calculating process image transfer time*.
4. Add the processing time at the scan cycle checkpoint. Corresponding guide values are found in the table *Operating system processing time at the scan cycle checkpoint*.
5. Include the extensions as a result of testing and commissioning functions. These values are found in the table *Cycle time extension due to testing and commissioning functions*.
The result you achieve is the
6. **cycle time**.

Extension of the cycle time as a result of interrupts and communication load

$$100 / (100 - \text{configured communication load in \%})$$

1. Multiply the cycle time by the factor as in the formula above.
2. Using the Instruction List, calculate the runtime of the program sections that hardware interrupts. Add the corresponding value from section *Calculating the cycle time*, table *Cycle time extension by interrupt nesting*.
3. Multiply both values by the CPU-specific extension factor of the user program processing time (see table "CPU communication services").
4. Add the value of the interrupt-processing program sequences to the theoretical cycle time, multiplied by the number of triggering (or expected) interrupt events within the cycle time.

The result you obtain is approximately the **actual cycle time**. Make a note of the result.

Response time

Table 6-8 Calculating the response time

| Shortest response time | Longest response time |
|---|---|
| - | Multiply the actual cycle time by a factor of 2. |
| Now add I/O delay. | Then, calculate the delays in the inputs and outputs and the DP cycle times on the PROFIBUS DP network. |
| The result is the shortest response time. | The result is the longest response time. |

6.5 Interrupt response time

6.5.1 Overview

Definition of the interrupt response time

The interrupt response time is the time that expires between the first occurrence of an interrupt signal and the call of the first interrupt OB statement. Generally, the following is valid: Interrupts having a higher priority take precedence. This means that the interrupt response time is increased by the program processing time of the higher-priority interrupt OBs and the interrupt OBs of equal priority which have not yet been executed (queued).

Process/diagnostic interrupt response times of the CPU

Table 6-9 Process/diagnostic interrupt response times

| CPU | Process interrupt response times | | | Diagnostic interrupt response times | |
|---------------|----------------------------------|---------------|--|-------------------------------------|--------|
| | External min. | External max. | Integrated inputs/outputs for integrated technology* | min. | Max. |
| CPU 315T-2 DP | 0.4 ms | 0.7 ms | - | 0.4 ms | 1.0 ms |
| CPU 317T-2 DP | 0.3 ms | 0.4 ms | - | 0.3 ms | 0.4 ms |

* The integrated inputs/outputs for integrated technology do not have interrupt capability.

Calculation

The formulae below show how you can calculate the minimum and maximum interrupt response times.

Table 6-10 Process/diagnostic interrupt response times

| Calculation of the minimum and maximum interrupt reaction time | |
|---|--|
| Minimum interrupt reaction time of the CPU + Minimum interrupt reaction time of the signal modules + DP cycle time on the PROFIBUS DP = Quickest interrupt reaction time | Maximum interrupt reaction time of the CPU + Maximum interrupt reaction time of the signal modules +2 x DP cycle time on the PROFIBUS DP The maximum interrupt reaction time is longer when the communication functions are active. The extra time is calculated using the following formula: tv: 200 µs + 1000 µs × n% Significant extension possible with n = cycle time extension through communication |

Signal modules

The **process interrupt response time** of signal modules is determined by the following factors:

- Digital input modules

Process interrupt response time = internal interrupt preparation time + input delay

You will find the times in the data sheet of the digital input module concerned.

- Analog input modules

Process interrupt response time = internal interrupt preparation time + conversion time

The internal interrupt processing time of the analog input modules is negligible. The conversion times can be taken from the data sheet of the analog input module concerned.

The **diagnostic interrupt response time** of signal modules is equivalent to the period that expires between the time a signal module detects a diagnostic event and the time this signal module triggers the diagnostic interrupt. This time is so small that it can be ignored.

Process interrupt processing

When the process interrupt OB 40 is called, the process interrupt is processed. Interrupts with higher priority interrupt process interrupt processing and direct access to the I/O is made when the statement is executed. When process interrupt processing is completed, either cyclic program processing is continued or other interrupt OBs with the same or a lower priority are called and processed.

6.5.2 Reproducibility of Time-Delay and Watchdog Interrupts

Definition of "Reproducibility"

Delay interrupt:

The period between the call of the first instruction in the interrupt OB and the programmed time of interrupt.

Watchdog interrupt:

The variation in the time interval between two successive calls, measured between the first instructions of the interrupt OB in each case.

Reproducibility

The following times apply for the CPUs described in this manual:

- Delay interrupt: +/- 200 µs
- Watchdog interrupt: +/- 200 µs

These times only apply if the interrupt can actually be executed at this time and if not interrupted, for example, by higher-priority interrupts or queued interrupts of equal priority.

6.6 Sample calculations

6.6.1 Example of cycle time calculation

Configuration

You have configured an S7-300 and equipped it with following modules in rack "0":

- 1 CPU 315T-2 DP
- 2 digital input modules SM 321; DI 32 x 24 VDC (4 bytes each in the PI)
- 2 digital output modules SM 322; DO 32 x 24 VDC / 0.5 A (4 bytes each in the PI)

User program

According to the Instruction List, your user program has a runtime of 5 ms. There is no active communication.

Calculating the cycle time

The cycle time for the example results from the following times:

- User program execution time:
approx. 5 ms x CPU-specific factor 1.10 = approx. 5.5 ms
- Process image transfer time
Process input image: $100 \mu\text{s} + 8 \text{ bytes} \times 37 \mu\text{s} = \text{Approx. } 0.396 \text{ ms}$
Process output image: $100 \mu\text{s} + 8 \text{ bytes} \times 37 \mu\text{s} = \text{Approx. } 0.396 \text{ ms}$
- Operating system runtime at scan cycle checkpoint:
approx. 0.5 ms

Cycle time = 5.5 ms + 0.396 ms + 0.396 ms + 0.5 ms = 6.792 ms.

Calculation of the actual cycle time

- There is no active communication.
- There is no interrupt handling.

Therefore, the **actual cycle time** is also 6.792 ms.

Calculation of the longest response time

Longest response time:

$6.792 \text{ ms} \times 2 = 13.584 \text{ ms}$.

- The delay in the inputs and outputs is negligible.
- All the components are plugged into rack 0; DP cycle times do not therefore have to be taken into account.
- There is no interrupt handling.

6.6.2 Example of response time calculation

Structure

You have configured an S7300 and equipped it with the following modules on a rack:

- One CPU 315T-2 DP
Configuration of the cycle load as a result of communication: 40 %
- 2 digital input modules SM 321; DI 32 x 24 VDC (4 bytes each in the PI)
- 3 digital output modules SM 322; DO 16 x 24 VDC/0.5 A (2 bytes each in the PI)
- 1 analog input module SM 331; AI 8 x 12-bit (not in the PI)
- 1 analog output module SM 332; AO 4 x 12-bit (not in the PI)

User program

According to the Instruction List, the user program has a runtime of 10.0 ms.

Cycle time calculation

The cycle time for the example results from the following times:

- User program execution time:
approx. $10 \text{ ms} \times \text{CPU-specific factor } 1.10 = \text{approx. } 11.0 \text{ ms}$
- Process image transfer time
Process image of inputs: $100 \mu\text{s} + 8 \text{ bytes} \times 37 \mu\text{s} = \text{approx. } 0.396 \text{ ms}$
Process image of outputs: $100 \mu\text{s} + 6 \text{ bytes} \times 37 \mu\text{s} = \text{approx. } 0.322 \text{ ms}$
- Operating system runtime at scan cycle checkpoint:
approx. 0.5 ms

The cycle time for the example results from the sum of the times listed:

Cycle time = $11.0 \text{ ms} + 0.396 \text{ ms} + 0.322 \text{ ms} + 0.5 \text{ ms} = 12.218 \text{ ms}$.

Calculation of the actual cycle time

Allowance for communication load:

$$12.218 \text{ ms} * 100 / (100-40) = 20.36 \text{ ms.}$$

Thus, under consideration of time slots, the **actual cycle time** is approx. **20 ms**.

Calculation of the longest response time

- Longest response time = 20 ms * 2 = 40 ms.
- Delays in the inputs and outputs
 - The maximum input delay of the digital input module SM 321; DI 32 x 24 VDC is **4.8 ms** per channel.
 - The output delay of the digital output module SM 322; DO 16 x 24 VDC / 0.5 A **can be neglected**.
 - The analog input module SM 331; AI 8 x 12 bit was configured for interference suppression at 50 Hz. This results in a conversion time of 22 ms per channel. Since 8 channels are active, a cycle time of **176 ms** results for the analog input module.
 - The analog output module SM 332; AO 4 x 12-bit was programmed for the measuring range of 0 ...10 Hz. This gives a conversion time of 0.8 ms per channel. Since 4 channels are active, a cycle time of 3.2 ms results. The settling time for the resistive load of 0.1 ms must still be added. The result is a response time of **3.3 ms** for an analog output.
- All the components are plugged into the central rack; DP cycle times do not therefore have to be taken into account.
- Response times plus I/O delay:
 - **Case 1:** An output channel of the digital output module is set when a signal is received at the digital input. The result is a response time of:
Response time = 40 ms + 4.8 ms = 44.8 ms.
 - **Case 2:** An analog value is fetched, and an analog value is output. The result is a response time of:
Longest response time = 40 ms + 176 ms + 3.3 ms = 219.3 ms.

6.6.3 Example of interrupt response time calculation

Structure

You have assembled an S7-300, consisting of one CPU 315T-2 DP and four digital modules in the central rack. One of the digital input modules is an SM 321; DI 16 x 24 VDC; with process/diagnostic interrupt function.

In the parameter assignment of the CPU and the SM, you have only enabled the process interrupt. You do not require time-driven processing, diagnostics and error handling. You have set a cycle load caused by communication of 20%.

You have set an input delay of 0.5 ms for the digital input module.

No activities are necessary at the cycle checkpoint.

Calculation

The process interrupt response time for the example results from the following times:

- Process interrupt response time of CPU 315T-2 DP: approx. 0.7 ms
- Extension by communication according to the formula:
 $200 \mu\text{s} + 1000 \mu\text{s} \times 20 \% = 400 \mu\text{s} = 0.4 \text{ ms}$
- Process interrupt response time of SM 321; DI 16 x 24 VDC:
 - Internal interrupt preparation time: 0.25 ms
 - Input delay: 0.5 ms
- Since the signal modules are plugged into the central rack, the DP cycle time on the PROFIBUS DP is not relevant.

The process interrupt response time results from the sum of the listed times:

Process interrupt response time = 0.7 ms + 0.4 ms + 0.25 ms + 0.5 ms = approx. 1.85 ms.

This calculated process interrupt response time is the time from a signal being applied across the digital input to the first statement in OB 40.

Technical Data

7.1 General technical Data

7.1.1 Rated voltages of S7-300

Rated operating voltages

The S7-300 modules operate at different rated voltages. The table shows the rated voltages and corresponding tolerances.

| Rated voltages | Tolerance |
|----------------|----------------------|
| 24 VDC | 20.4 VDC to 28.8 VDC |
| 120 VAC | 93 VAC to 132 VAC |
| 230 VAC | 187 VAC to 264 VAC |

7.1.2 Technical specifications of the Micro Memory Card

Plug-in SIMATIC Micro Memory Cards

Memory modules available:

Table 7-1 Available SIMATIC Micro Memory Cards

| Type | | | Order No. | Comment |
|-------------------|---|----|---------------------|---|
| Micro memory card | 4 | MB | 6ES7 953-8LMxx-0AA0 | With V2.6/V4.1.1, if possible |
| Micro memory card | 8 | MB | 6ES7 953-8LPxx-0AA0 | Required for an operating system update |

7.1.3 Standards and certifications

Introduction

Contents of general technical data:

- standards and test values satisfied by modules of the S7-300 automation system
- test criteria of S7-300 modules.

The Technology CPU orientates itself on the planned standards

- PLCopen - Technical Committee 2 – Task Force Function blocks for motion control Version 1.0
- PROFIdrive Profile 3.1 (Firmware Version 4.1)

CE approval



The S7-300 automation system satisfies requirements and safety-related objectives according to EC Directives listed below and conforms with the harmonized European standards (EN) for programmable controllers announced in the Official Journals of the European Community:

- 73/23/EEC "Electrical Equipment Designed for Use within Certain Voltage Limits" (Low-Voltage Directive)
- 89/336/EEC "Electromagnetic Compatibility" (EMC Directive)
- 94/9/EC "Equipment and protective systems intended for use in potentially explosive atmospheres" (Explosion Protection Directive)

The EC declaration of conformity is held on file available to competent authorities at:

Siemens Aktiengesellschaft
Automation & Drives
A&D AS RD ST PLC
PO Box 1963
D-92209 Amberg

UL approval



Underwriters Laboratories Inc. complying with

- UL 508 (Industrial Control Equipment)

CSA approval



Canadian Standards Association to

- C22.2 No. 142 (Process Control Equipment)

or



Underwriters Laboratories Inc. complying with

- UL 508 (Industrial Control Equipment)
- CSA C22.2 No. 142 (Process Control Equipment)

or



HAZ. LOC.

Underwriters Laboratories Inc. complying with

- UL 508 (Industrial Control Equipment)
- CSA C22.2 No. 142 (Process Control Equipment)
- UL 1604 (Hazardous Location)
- CSA-213 (Hazardous Location)

APPROVED for use in
Class I, Division 2, Group A, B, C, D Tx;
Class I, Zone 2, Group IIC Tx

Note

Currently valid approvals can be found on the rating plate of the relevant module.

FM approval



Factory Mutual Research (FM) to
Approval Standard Class Number 3611, 3600, 3810
APPROVED for use in Class I, Division 2, Group A, B, C, D Tx;
Class I, Zone 2, Group IIC Tx

ATEX approval



to EN 60079-15:2003 (Electrical apparatus for potentially explosive atmospheres; Type of protection "n")



II 3 G EEx nA II Parts 4 to 6

Tick-mark for Australia



The S7-300 automation system satisfies requirements of standards to AS/NZS 2064 (Class A).

IEC 61131

The S7-300 automation system satisfies requirements and criteria to IEC 61131-2 (Programmable Controllers, Part 2: Equipment requirements and tests).

Marine approval

Classification societies:

- ABS (American Bureau of Shipping)
- BV (Bureau Veritas)
- DNV (Det Norske Veritas)
- GL (Germanischer Lloyd)
- LRS (Lloyds Register of Shipping)
- Class NK (Nippon Kaiji Kyokai)

Use in industrial environments

SIMATIC products are designed for industrial applications.

Table 7-2 Use in industrial environments

| Field of application | Noise emission requirements | Noise immunity requirements |
|----------------------|-----------------------------|-----------------------------|
| Industry | EN 61000-6-4: 2001 | EN 61000-6-2: 2001 |

Use in residential areas

To operate an S7-300 in a residential area, its RF emission must comply with Limit Value Class B to EN 55011.

The following measures are recommended to ensure the interference complies with limit value class B:

- S7-300 installation in grounded switch cabinets / cubicles
- Use of noise filters in the supply lines

 **WARNING**

Personal injury and damage to property may occur.

In potentially explosive environments, there is a risk of injury or damage if you disconnect any connectors while the S7-300 is in operation.

Always isolate the S7-300 operated in such areas before you disconnect and connectors.

7.1.4 Electromagnetic compatibility

Definition

Electromagnetic compatibility (EMC) is the ability of an electrical installation to function satisfactorily in its electromagnetic environment without interfering with that environment.

The S7-300 modules also satisfy requirements of EMC legislation for the European domestic market. Compliance of the S7-300 system with specifications and directives on electric configuration is prerequisite.

Pulseshaped disturbance

The table below shows the EMC compatibility of S7 modules in areas subject to pulse-shaped disturbance.

| Pulse-shaped disturbance | Test voltage | corresponds with degree of severity |
|--|--|-------------------------------------|
| Electrostatic discharge to IEC 61000-4-2 | Air discharge: ± 8 kV | 3 |
| | Contact discharge ± 4 kV | 2 |
| Burst pulses (high-speed transient disturbance) to IEC 61000-4-4. | 2 kV (power supply lines) | 3 |
| | 2 kV (signal lines > 3 m) | 3 |
| | 1 kV (signal lines < 3 m) | |
| High-energy single pulse (surge) to IEC 61000-4-5 External protective circuitry required (Refer to S7-300 CPU 31xC and CPU 31x Operating Instructions: Configuration, section "Protection against lightning and overvoltages") | | 3 |
| • asymmetric coupling | 2 kV (power supply lines) DC with protective elements 2 kV (signal/ data line only > 3 m), with protective elements as required | |
| • symmetric coupling | 1 kV (power supply lines) DC with protective elements 1 kV (signal/ data line only > 3 m), with protective elements as required | |

Additional measures

When connecting an S7-300 system to the public network, always ensure compliance with Limit Value Class B to EN 55022.

Sinusoidal disturbance

The table below shows the EMC compatibility of S7-300 modules in areas subject to sinusoidal disturbance.

| Sinusoidal disturbance | Test values | corresponds with degree of severity |
|---|--|-------------------------------------|
| RF radiation (electromagnetic fields) to IEC 61000-4-3 | 10 V/m, with 80% amplitude modulation of 1 kHz in the 80 MHz to 1000 MHz range 10 V/m, with 50% pulse modulation at 900 MHz | 3 |
| RF conductance on cables and cable shielding to IEC 61000-4-6 | Test voltage 10 V, with 80% amplitude modulation of 1 kHz in the 9 MHz to 80 MHz range | 3 |

Emission of radio interference

Electromagnetic interference to EN 55011: Limit Class A, Group 1 (measured at a distance of 10 m.)

| Frequency | Noise emission |
|---------------------|-----------------------|
| 30 MHz to 230 MHz | < 40 dB (μ V/m)Q |
| 230 MHz to 1000 MHz | < 47 dB (μ V/m)Q |

Noise emission via AC mains to EN 55011: Limit value class A, Group 1.

| Frequency | Noise emission |
|---------------------|--|
| 0.15 MHz to 0.5 MHz | < 79 dB (μ V/m)Q < 66 dB (μ V/m)M |
| 0.5 MHz to 5 MHz | < 73 dB (μ V/m)Q < 60 dB (μ V/m)M |
| 5 MHz to 30 MHz | < 73 dB (μ V/m)Q < 60 dB (μ V/m)M |

7.1.5 Shipping and storage conditions for modules and backup batteries

Introduction

The shipping and storage conditions of S7-300 modules surpass requirements to IEC 61131-2. The data below apply to modules shipped or put on shelf in their original packing.

The modules are compliant with climatic conditions to IEC 60721-3-3, Class 3K7 (storage), and with IEC 60721-3-2, Class 2K4 (shipping.)

Mechanical conditions are compliant with IEC 60721-3-2, Class 2M2.

Shipping and storage conditions for modules

| Type of condition | Permissible range |
|---|---|
| Free fall (in shipping package) | ≤ 1 m |
| Temperature | - 40 °C to + 70 °C |
| Barometric pressure | 1080 hPa to 660 hPa (corresponds with an altitude of -1000 m to 3500 m) |
| Relative humidity | 10% to 95%, no condensation |
| Sinusoidal oscillation to IEC 60068-2-6 | 5 Hz to 9 Hz: 3.5 mm 9 Hz to 150 Hz: 9.8 m/s ² |
| Shock to IEC 60068-2-29 | 250 m/s ² , 6 ms, 1000 shocks |

7.1.6 Mechanical and climatic environmental conditions for S7-300 operation

Operating conditions

S7-300 systems are designed for stationary use in weather-proof locations. The operating conditions surpass requirements to DIN IEC 60721-3-3.

- Class 3M3 (mechanical requirements)
- Class 3K3 (climatic requirements)

Use with additional measures

The S7-300 may not be used under the conditions outlined below without taking additional measures:

- at locations with a high degree of ionizing radiation
- in aggressive environments caused, for example, by
 - the development of dust
 - corrosive vapors or gases
 - strong electric or magnetic fields
- in installations requiring special monitoring, for example
 - elevators
 - electrical plants in potentially hazardous areas

An additional measure could be an installation of the S7-300 in a cabinet or housing.

Mechanical environmental conditions

The table below shows the mechanical environmental conditions in the form of sinusoidal oscillations.

| Frequency band | Continuous | Infrequently |
|--------------------|-----------------------------|---------------------------|
| 10 Hz ≤ f ≤ 58 Hz | 0.0375 mm amplitude | 0.75 mm amplitude |
| 58 Hz ≤ f ≤ 150 Hz | 0.5 g constant acceleration | 1 g constant acceleration |

Reducing vibrations

If your S7-300 modules are exposed to severe shock or vibration, take appropriate measures to reduce acceleration or the amplitude.

We recommend the installation of the S7-300 on damping materials (for example, rubber-bonded-to-metal mounting.)

Test of mechanical environmental conditions

The table below provides important information with respect to the type and scope of the test of ambient mechanical conditions.

| Condition tested | Test Standard | Comment |
|------------------|--|--|
| Vibration | Vibration test to IEC 60068-2-6 (sinusoidal) | Type of oscillation: Frequency sweeps with a rate of change of 1 octave/minute. 10 Hz ≤ f ≤ 58 Hz, constant amplitude 0.075 mm 58 Hz ≤ f ≤ 150 Hz, constant acceleration 1 g Duration of oscillation: 10 frequency sweeps per axis at each of three vertically aligned axes |
| Shock | Shock, tested to IEC 60068-2-27 | Type of shock: half-sine Severity of shock: 15 g peak value, 11 ms duration Direction of shock: 3 shocks in each direction (+/-) at each of three vertically aligned axes |
| Continuous shock | Shock, tested to IEC 60068-2-29 | Type of shock: half-sine Severity of shock: 25 g peak value, 6 ms duration Shock direction: 1000 shocks in each direction (+/-) at each of three vertically aligned axes |

Climatic environmental conditions

The S7-300 may be operated on following environmental conditions:

| Environmental conditions | Permissible range | Comments |
|--|--|---|
| Temperature: horizontal mounting position: vertical mounting position: | 0°C to 60°C 0°C to 40°C | |
| Relative humidity | 10 % to 95 % | No condensation, corresponds to relative humidity (RH) Class 2 to IEC 61131, Part 2 |
| Barometric pressure | 1080 hPa to 795 hPa | Corresponds with an altitude of -1000 m to 2000 m |
| Concentration of pollutants | SO ₂ : < 0.5 ppm; RH < 60 %, no condensation H ₂ S: < 0.1 ppm; RH < 60 %, no condensation | Test: 10 ppm; 4 days Test: 1 ppm; 4 days |

7.1.7 Specification of dielectric tests, protection class, degree of protection, and rated voltage of S7-300

Test voltage

Proof of dielectric strength must be provided in the type test at a test voltage to IEC 61131-2:

| Circuits with rated voltage V_e to other circuits or ground. | Test voltage |
|--|--------------|
| < 50 V | 500 VDC |
| < 150 V | 2500 VDC |
| < 250 V | 4000 VDC |

Protection class

Protection class I to IEC 60536, i.e., a protective conductor must be connected to the mounting rail!

Protection against the ingress of foreign matter and water

- Degree of protection IP 20 to IEC 60529, i.e., protection against contact with standard probes.

No protection against the ingress of water.

7.1.8 Dimension drawing

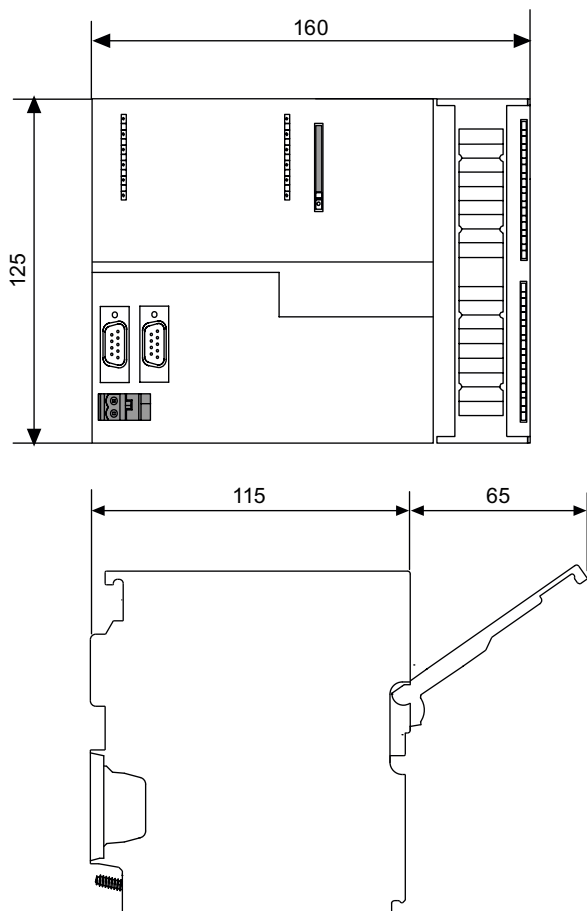

Dimension drawing of Technology CPU

7.2 CPU 315T-2 DP and CPU 317T-2 DP

Technical data

- CPU 315T-2 DP, order number 6ES7315-6TH13-0AB0 and
- CPU 317T-2 DP, order number 6ES7317-6TK13-0AB0

| | 6ES7315-6TH13-0AB0 | 6ES7317-6TK13-0AB0 |
|--|---|---|
| Product status | | |
| Hardware product status | 01 | 01 |
| Firmware version | CPU: V 2.6; integrated technology: V 4.1.1 | CPU: V 2.6; integrated technology: V 4.1.1 |
| associated programming package | STEP 7 V 5.4 SP2 or higher and S7-Technology option package V4.1 | STEP 7 V 5.4 SP2 or higher and S7-Technology option package V4.1 |
| Supply voltages | | |
| Rated value | | |
| • DC 24 V | Yes | Yes |
| • permissible range, lower limit (DC) | 20.4 V | 20.4 V |
| • permissible range, upper limit (DC) | 28.8 V | 28.8 V |
| Voltages and currents | | |
| Load voltage L+ | | |
| • Rated value (DC) | 24 V | 24 V |
| • reverse polarity protection | Yes | Yes |
| external protection for supply cables (recommendation) | Min. 2 A | Min. 2 A |
| Current consumption | | |
| Inrush current, max. | 2.5 A | 2.5 A |
| I^2t | 1 A ² s | 1 A ² s |
| Current consumption (in no-load operation), typ. | 200 mA | 200 mA |
| Power loss, typ. | 6 W | 6 W |
| Technology objects | | |
| • Total | 32 (axes, cams, output cams, cam tracks, measuring inputs, external encoders) | 64 (axes, cams, output cams, cam tracks, measuring inputs, external encoders) |
| • Axes | 8 axes (virtual or real axes) | 32 axes (virtual or real axes) |
| • Cams | 16 output cams 8 output cams can be output as "high-speed output cams" on the integrated outputs of the Technology CPU. A further 24 output cams can be implemented via the distributed I/Os (e.g. on the ET 200M or ET 200S). These can be implemented as "high-speed output cams" on the TM15 and TM17 High Feature. | 32 output cams 8 output cams can be output as "high-speed output cams" on the integrated outputs of the Technology CPU. A further 24 output cams can be implemented via the distributed I/Os (e.g. on the ET 200M or ET 200S). These can be implemented as "high-speed output cams" on the TM15 and TM17 High Feature. |
| • Cam tracks | 16 | 32 |

Technical Data

7.2 CPU 315T-2 DP and CPU 317T-2 DP

| | 6ES7315-6TH13-0AB0 | 6ES7317-6TK13-0AB0 |
|--|--|--|
| <ul style="list-style-type: none"> • Cams, total in cam tracks • Cam disks • Measuring inputs • External encoders | 512 (32 cams per cam track) 16 8 8 | 1024 (32 cams per cam track) 32 16 16 |
| Memory | | |
| Type of storage | | |
| <ul style="list-style-type: none"> • RAM <ul style="list-style-type: none"> – integrated – expandable • Load memory <ul style="list-style-type: none"> – pluggable (MMC) – pluggable (MMC), max. – Data management on MMC (after last programming), min. | 256 KByte No Yes 8 MByte 10 years | 1024 KByte No Yes 8 MByte 10 years |
| Backup | | |
| <ul style="list-style-type: none"> • present | Yes; maintenance-free | Yes; maintenance-free |
| CPU/blocks | | |
| Number of blocks (total) | 1,024 | 2,048 |
| FB | | |
| <ul style="list-style-type: none"> • Number, max. • Size, max. | 1,023; See Operation List 64 KByte | 2,047; See Operation List 64 KByte |
| FC | | |
| <ul style="list-style-type: none"> • Number, max. • Size, max. | 1,024; See Operation List 64 KByte | 2,048; See Operation List 64 KByte |
| OB | | |
| <ul style="list-style-type: none"> • Size, max. • Number of free cycle OBs • Number of time alarm OBs • Number of delay alarm OBs • Number of watchdog interrupts • Number of process alarm OBs • Number of DPV1 OBs • Number of synchronous cycle interrupt OBs • Number of technology synchronization interrupt OB • Number of startup OBs • Number of asynchronous error OBs • Number of synchronous error OBs • Number of diagnostic interrupts | 64 KByte 1 1 1 1 1 3 1 1 1 5 2 1 | 64 KByte 1 1 2 4 1 3 1 1 1 5 2 1 |

| | 6ES7315-6TH13-0AB0 | 6ES7317-6TK13-0AB0 |
|---|--|--|
| Nesting depth | | |
| • per priority class | 8 | 16 |
| • additional within an error OB | 4 | 4 |
| CPU/processing times | | |
| for bit operations, min. | 0.1 µs | 0.05 µs |
| for word operations, min. | 0.2 µs | 0.2 µs |
| for fixed point arithmetic, min. | 2 µs | 0.2 µs |
| for floating point arithmetic, min. | 3 µs | 1 µs |
| Times/counters and their retentivity | | |
| S7 counter | | |
| • Number | 256 | 512 |
| • Retentivity | | |
| – adjustable | Yes | Yes |
| – preset | 8 | 8 |
| • Counting range | | |
| – adjustable | Yes | Yes |
| – lower limit | 0 | 0 |
| – upper limit | 999 | 999 |
| IEC counter | | |
| • present | Yes | Yes |
| • Type | SFB | SFB |
| • Number | Unlimited (limited only by RAM capacity) | Unlimited (limited only by RAM capacity) |
| S7 times | | |
| • Number | 256 | 512 |
| • Retentivity | | |
| – adjustable | Yes | Yes |
| – preset | No retentivity | No retentivity |
| • Time range | | |
| – lower limit | 10 ms | 10 ms |
| – upper limit | 9,990 s | 9,990 s |
| IEC timer | | |
| • present | Yes | Yes |
| • Type | SFB | SFB |
| • Number | Number unlimited (limited only by work memory) | Number unlimited (limited only by work memory) |
| Data areas and their retentivity | | |
| Size of retentive data area, max. | All DBs, max. 128 kByte | All DBs, max. 256 kByte |
| Flag | | |
| • Number, max. | 2,048 Byte | 4,096 Byte |
| • Retentivity available | Yes; MB 0 to MB 2047 | Yes; MB 0 to MB 4.095 |
| • Retentivity preset | MB 0 to MB 15 | MB 0 to MB 15 |
| • Number of clock memories | 8; 1 memory byte | 8; 1 memory byte |

| | 6ES7315-6TH13-0AB0 | 6ES7317-6TK13-0AB0 |
|--|--------------------------|--------------------------|
| Data blocks | | |
| • Number, max. | 1,023; DB 0 reserved | 2,047; DB 0 reserved |
| • Size, max. | 64 KByte | 64 KByte |
| • Remanence adjustable | Yes | Yes |
| • Retentivity preset | Yes | Yes |
| Local data | | |
| • per priority class, max. | 1,024 Byte | 1,024 Byte |
| Address area | | |
| I/O address area | | |
| • Inputs | 2 KByte | 2 KByte |
| • Outputs | 2 KByte | 2 KByte |
| • of which, distributed | | |
| – Inputs | 2 KByte | 2 KByte |
| – Outputs | 2 KByte | 2 KByte |
| Process image | | |
| • Inputs, adjustable | 2048 Byte | 2048 Byte |
| • Outputs, adjustable | 2048 Byte | 2048 Byte |
| • Inputs, preset | 128 Byte | 256 Byte |
| • Outputs, preset | 128 Byte | 256 Byte |
| Digital channels | | |
| • Inputs | 16,384 | 65,536 |
| • Outputs | 16,384 | 65,536 |
| • Inputs, of which central | 512 | 512 |
| • Outputs, of which central | 512 | 512 |
| Analog channels | | |
| • Inputs | 1,024 | 4,096 |
| • Outputs | 1,024 | 4,096 |
| • Inputs, of which central | 64 | 64 |
| • Outputs, of which central | 64 | 64 |
| Hardware config. | | |
| CPUs in the central rack, max | 1 | 1 |
| CPUs in the extension rack | 0 | 0 |
| Racks, max. | 1 | 1 |
| Modules per rack, max. | 8 | 8 |
| Number of DP masters | | |
| • integrated | 2; 1 DP and 1 DP (drive) | 2; 1 DP and 1 DP (drive) |
| • via CP | 2; for DP | 2; for DP |
| Number of operable FMs and CPs (recommended) | | |
| • FM | 8 | 8 |
| • CP, point-to-point | 8 | 8 |
| • CP, LAN | 10 | 10 |

| | 6ES7315-6TH13-0AB0 | 6ES7317-6TK13-0AB0 |
|--|--|--|
| Time | | |
| Clock | | |
| • Hardware clock (real-time clock) | Yes | Yes |
| • buffered and synchronizable | Yes | Yes |
| • Backup time | 6 weeks; at 40 °C ambient temperature | 6 weeks; at 40 °C ambient temperature |
| • Deviation per day, max. | 10 s | 10 s |
| Operating hours counter | | |
| • Number | 1 | 4 |
| • Number/Number range | 0 | 0 to 3 |
| • Range of values | 0 to 2 ³¹ hours (when using SFC 101) | 0 to 2 ³¹ hours (when using SFC 101) |
| • Granularity | 1 hour | 1 hour |
| • Retentive | Yes; Must be restarted at each restart | Yes; Must be restarted at each restart |
| Clock synchronization | | |
| • supported | Yes | Yes |
| • to MPI, Master | Yes | Yes |
| • to MPI, Slave | Yes | Yes |
| • to DP, Master | Yes | Yes |
| • to TO, Slave | Yes | Yes |
| • in AS, Master | Yes | Yes |
| • in AS, Slave | Yes | Yes |
| S7 message functions | | |
| Number of login stations for message functions, max. | 16; Depending on the configured connections for PG/OP and S7 basic communication | 32; Depending on the configured connections for PG/OP and S7 basic communication |
| Process diagnostic messages | Yes | Yes |
| simultaneously active Alarm-S blocks, max. | 40 | 60 |
| Test commissioning functions | | |
| Status/control | | |
| • Status/control variable | Yes | Yes |
| • Variables | Inputs, outputs, memory bits, DB, times, counters | Inputs, outputs, memory bits, DB, times, counters |
| • Number of variables, max. | 30 | 30 |
| • of which status variable, max. | 30 | 30 |
| • of which control variable, max. | 14 | 14 |
| Forcing | | |
| • Forcing | Yes | Yes |
| • Force, variables | Inputs, outputs | Inputs, outputs |
| • Number of variables, max. | 10 | 10 |
| Status block | Yes | Yes |
| Single step | Yes | Yes |
| Number of breakpoints | 2 | 2 |
| Diagnostic buffer | | |

| | 6ES7315-6TH13-0AB0 | 6ES7317-6TK13-0AB0 |
|--|---|---|
| <ul style="list-style-type: none"> present Number of entries, max. adjustable | <p>Yes 100 No</p> | <p>Yes 100 No</p> |
| Communication functions | | |
| PG/OP communication | Yes | Yes |
| Routing | Yes | Yes |
| Global data communication | | |
| <ul style="list-style-type: none"> supported Number of GD loops, max. Number of GD packets, max. Number of GD packets, transmitter, max. Number of GD packets, receiver, max. Size of GD packets, max. Size of GD packet (of which consistent), max. | <p>Yes 8 8 8 8 22 Byte 22 Byte</p> | <p>Yes 8 8 8 8 22 Byte 22 Byte</p> |
| S7 basic communication | | |
| <ul style="list-style-type: none"> supported Useful data per job, max. Useful data per job (of which consistent) max. | <p>Yes 76 Byte 76 Byte; 76 bytes (with X_SEND or X_RCV); 64 bytes (with X_PUT or X_GET as server)</p> | <p>Yes 76 Byte 76 Byte; 76 bytes (with X_SEND or X_RCV); 64 bytes (with X_PUT or X_GET as server)</p> |
| S7 communication | | |
| <ul style="list-style-type: none"> supported as server as client User data per job, max. User data per job, of which consistent, max. | <p>Yes Yes Yes; via CP and loadable FB 180 Byte; With PUT/GET 64 Byte; as server</p> | <p>Yes Yes Yes; via CP and loadable FB 180 Byte; With PUT/GET 160 Byte; as server</p> |
| S5-compatible communication | | |
| <ul style="list-style-type: none"> supported | Yes; via CP and loadable FC | Yes; via CP and loadable FC |
| Number of connections | | |
| <ul style="list-style-type: none"> overall usable for PG communication reserved for PG communication adjustable for PG communication, min. adjustable for PG communication, max. usable for OP communication reserved for OP communication adjustable for OP communication, min. adjustable for OP communication, max. usable for S7 basic communication | <p>16 15 1 1 15 15 1 1 15 14</p> | <p>32 31 1 1 31 31 1 1 31 30</p> |

| | 6ES7315-6TH13-0AB0 | 6ES7317-6TK13-0AB0 |
|---|---|---|
| <ul style="list-style-type: none"> reserved for S7-Basic communication | 0 | 0 |
| <ul style="list-style-type: none"> adjustable for S7-Basic communication, min. | 0 | 0 |
| <ul style="list-style-type: none"> adjustable for S7-Basic communication, max. | 14 | 30 |
| 1st interface | | |
| Type of interface | integrated RS 485 interface | integrated RS 485 interface |
| Physics | RS 485 | RS 485 |
| isolated | Yes | Yes |
| Power supply to interface (15 to 30 V DC), max. | 200 mA | 200 mA |
| Functionality | | |
| <ul style="list-style-type: none"> MPI | Yes | Yes |
| <ul style="list-style-type: none"> DP master | Yes | Yes |
| <ul style="list-style-type: none"> DP slave | Yes | Yes |
| <ul style="list-style-type: none"> Point-to-point coupling | No | No |
| MPI | | |
| <ul style="list-style-type: none"> Services <ul style="list-style-type: none"> PG/OP communication Routing Global data communication S7 basic communication S7 communication S7 communication, as client S7 communication, as server | <ul style="list-style-type: none"> Yes Yes Yes Yes Yes Yes; via CP and loadable FB Yes | <ul style="list-style-type: none"> Yes Yes Yes Yes Yes Yes; via CP and loadable FB Yes |
| <ul style="list-style-type: none"> Transmission speeds, max. | 12 Mbit/s | 12 Mbit/s |
| DP master | | |
| <ul style="list-style-type: none"> Services <ul style="list-style-type: none"> PG/OP communication Routing Global data communication S7 basic communication S7 communication Equidistance support Synchronous cycle SYNC/FREEZE DPV1 | <ul style="list-style-type: none"> Yes Yes No Yes Yes Yes Yes, OB 61 Yes Yes | <ul style="list-style-type: none"> Yes Yes No Yes Yes Yes Yes, OB 61 Yes Yes |
| <ul style="list-style-type: none"> Transmission speeds, max. | 12 Mbit/s | 12 Mbit/s |
| <ul style="list-style-type: none"> Number of DP slaves, max. | 124 | 124 |

| | 6ES7315-6TH13-0AB0 | 6ES7317-6TK13-0AB0 |
|--|---|---|
| <ul style="list-style-type: none"> Address area <ul style="list-style-type: none"> Inputs, max. Outputs, max. | 2 KByte; 244 bytes per DP slave 2 KByte; 244 bytes per DP slave | 2 KByte; 244 bytes per DP slave 2 KByte; 244 bytes per DP slave |
| DP slave | | |
| <ul style="list-style-type: none"> Services <ul style="list-style-type: none"> Routing Global data communication S7 basic communication S7 communication direct data exchange (cross traffic) DPV1 Transmission speeds, max. automatic baud rate search Transfer memory <ul style="list-style-type: none"> Inputs Outputs Address areas, max. User data per address area, max. | Yes No No Yes, only as server Yes No 12 Mbit/s Yes, only with passive interface 244 Byte 244 Byte 32 32 Byte | Yes No No Yes, only as server Yes No 12 Mbit/s Yes, only with passive interface 244 Byte 244 Byte 32 32 Byte |
| 2nd interface | | |
| Type of interface | integrated RS 485 interface | integrated RS 485 interface |
| Physics | RS 485 | RS 485 |
| isolated | Yes | Yes |
| Power supply to interface (15 to 30 V DC), max. | 200 mA | 200 mA |
| Functionality <ul style="list-style-type: none"> MPI DP master DP slave Point-to-point coupling | No Yes; DP(DRIVE)-Master No No | No Yes; DP(DRIVE)-Master No No |
| DP master <ul style="list-style-type: none"> Services <ul style="list-style-type: none"> PG/OP communication Routing Global data communication S7 basic communication S7 communication Equidistance support Synchronous cycle SYNC/FREEZE Activation/deactivation of DP slaves DPV1 Transmission speeds, max. Number of DP slaves, max. Address area | No Yes No No No Yes Yes No Yes No 12 Mbit/s 64 | No Yes No No No Yes Yes No Yes No 12 Mbit/s 64 |

| | 6ES7315-6TH13-0AB0 | 6ES7317-6TK13-0AB0 |
|--|---|---|
| - Inputs, max. | 1 KByte; 244 bytes per DP slave | 1 KByte; 244 bytes per DP slave |
| - Outputs, max. | 1 KByte; 244 bytes per DP slave | 1 KByte; 244 bytes per DP slave |
| GSD file | http://www.automation.siemens.com/csi/gsd | http://www.automation.siemens.com/csi/gsd |
| CPU/programming | | |
| Programming language | | |
| • LAD | Yes | Yes |
| • FUP | Yes | Yes |
| • AWL | Yes | Yes |
| Operational stocks | See instruction list | See instruction list |
| Nesting levels | 8 | 8 |
| User program protection/password protection | Yes | Yes |
| System functions (SFC) | See instruction list | see instruction list |
| System function blocks (SFB) | see instruction list | see instruction list |
| Cycle time monitoring | | |
| • lower limit | 1 ms | 1 ms |
| • upper limit | 6,000 ms | 6,000 ms |
| • adjustable | Yes | Yes |
| • preset | 150 ms | 150 ms |
| Digital inputs | | |
| Number of digital inputs | 4 | 4 |
| Cable length | | |
| Cable length, shielded, max. | 1,000 m | 1,000 m |
| Cable length unshielded, max. | 600 m | 600 m |
| Input characteristic curve to IEC 1131, Typ 1 | Yes | Yes |
| Input voltage | | |
| • Rated value, DC | 24 V | 24 V |
| • for signal "0" | -3 to +5 V | -3 to +5 V |
| • for signal "1" | 15 to 30 V | 15 to 30 V |
| Input current | | |
| • for signal "1", typ. | 7 mA | 7 mA |
| Input delay (for rated value of input voltage) | | |
| • for counter/technological functions | | |
| - at "0" to "1", max. | 10 µs; typically | 10 µs; typically |
| - at "1" to "0", max. | 10 µs; typically | 10 µs; typically |
| Digital outputs | | |
| Number of digital outputs | 8 | 8 |
| Cable length | | |
| • Cable length, shielded, max. | 1,000 m | 1,000 m |
| • Cable length unshielded, max. | 600 m | 600 m |
| Short-circuit protection of the output | Yes | Yes |
| • Response threshold, typ. | 1.0 A | 1.0 A |

Technical Data

7.2 CPU 315T-2 DP and CPU 317T-2 DP

| | 6ES7315-6TH13-0AB0 | 6ES7317-6TK13-0AB0 |
|--|------------------------------|------------------------------|
| Limitation of inductive shutdown voltage to | 2L+ (-48 V) | 2L+ (-48 V) |
| Lamp load, max. | 5 W | 5 W |
| Controlling a digital input | Yes | Yes |
| Output voltage | | |
| • for signal "0" DC, max. | 3 V | 3 V |
| • for signal "1", min. | 2L+ (-2.5 V) | 2L+ (-2.5 V) |
| Output current | | |
| • for signal "1" rated value | 0.5 A | 0.5 A |
| • for signal "1" permissible range, 0 to 60 °C, min. | 5 mA | 5 mA |
| • for signal "1" permissible range, 0 to 60 °C, max. | 0,6 A | 0,6 A |
| • for signal "0" residual current, max. | 0.3 mA | 0.3 mA |
| Parallel switching of 2 outputs | | |
| • for increased power | No | No |
| • for redundant control of a load | No | No |
| Switching frequency | | |
| • with resistive load, max. | 100 Hz | 100 Hz |
| • with inductive load, max. | 0.2 Hz; to IEC 947-5-1, DC13 | 0.2 Hz; to IEC 947-5-1, DC13 |
| • on lamp load, max. | 100 Hz | 100 Hz |
| Aggregate current of the outputs (per group) | | |
| • horizontal installation | | |
| – up to 40 °C, max. | 4 A | 4 A |
| – up to 60 °C, max. | 3 A | 3 A |
| Load impedance range | | |
| • lower limit | 48 Ω | 48 Ω |
| • upper limit | 4 kΩ | 4 kΩ |
| Encoder | | |
| Connectable encoders | | |
| • 2-wire BEROS | No | No |
| Status information/alarms/diagnostics | | |
| Alarms | | |
| • Alarms | No | No |
| Diagnoses | | |
| • Diagnostic functions | No | No |
| Diagnostics indication LED | | |
| • Status indicator digital output (green) | Yes | Yes |
| • Status indicator digital input (green) | Yes | Yes |

| | 6ES7315-6TH13-0AB0 | 6ES7317-6TK13-0AB0 |
|--|--------------------|--------------------|
| Isolation | | |
| Isolation checked with | 500 VDC | 500 VDC |
| Isolation | | |
| Galvanic isolation, digital inputs | | |
| • between the channels and the backplane bus | Yes | Yes |
| Isolation, digital outputs | | |
| • between the channels and the backplane bus | Yes | Yes |
| Permissible potential difference | | |
| between different circuits | 75 VDC / 60 VAC | 75 VDC / 60 VAC |
| Dimensions | | |
| Dimensions | | |
| Width | 160 mm | 160 mm |
| Height | 125 mm | 125 mm |
| Depth | 130 mm | 130 mm |
| Weights | | |
| Weight, approx. | 750 g | 750 g |

7.3 Integrated Inputs/Outputs for Technology

7.3.1 Arrangement of integrated inputs/outputs for integrated technology

Introduction

The Technology CPU has 4 digital inputs and 8 digital outputs integrated. You use these inputs and outputs for technology functions, e.g. reference point acquisition (reference cams) or high-speed output cam switching signals.

You can also use the digital inputs / outputs with the technology functions "MC_ReadPeriphery" and "MC_WritePeriphery" in the STEP 7 user program.

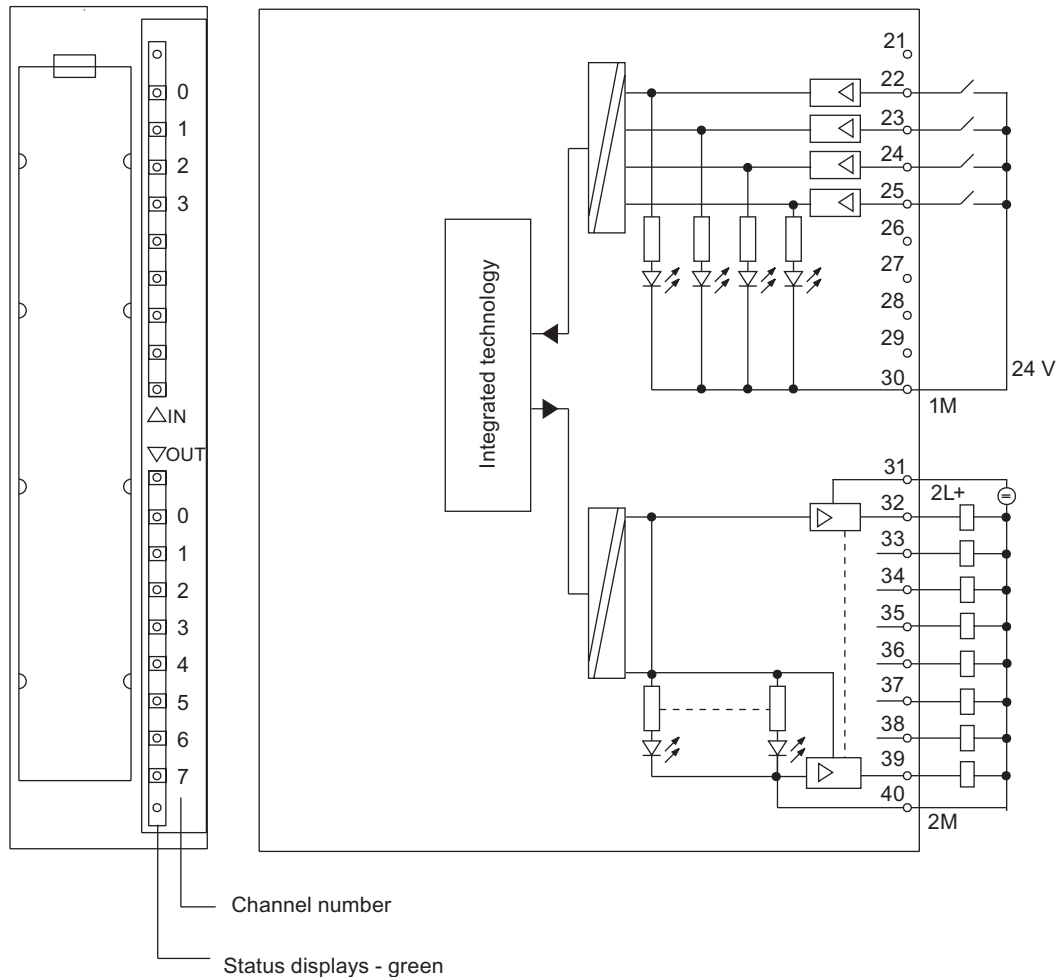

Figure 7-1 Block diagram of integrated inputs/outputs for integrated technology

Appendix

A.1 Information for the Changeover to the Technology CPU

A.1.1 Scope

Who should read this information?

Are you already using a CPU 31x, a CPU 31x IFM or a CPU 31x-2 DP from the SIMATIC S7-300 series and now want to upgrade to a Technology CPU?

Please note that problems may occur when you download your user program to the "new" CPU.

Please read the following information regarding migration to the Technology CPU.

A.1.2 Changed behavior of certain SFCs

SFC 13, SFC 56 and SFC 57 which work asynchronously...

Some of the SFCs that work asynchronously, when used on CPUs 312 IFM to 318-2 DP, were always, or under certain conditions, processed after the first call ("quasi-synchronous").

On the Technology CPU, these SFCs actually run asynchronously. Asynchronous processing may cover multiple OB1 cycles. As a result, a wait loop may turn into an endless loop within an OB.

The following are affected:

- SFC 13 "DPNRM_DG"

On CPUs 312 IFM to 318-2 DP, this SFC always works "quasi synchronously" when it is called in OB 82. On the Technology CPU, it generally works asynchronously.

Note

In the user program, the job should merely be started in OB 82. The data should be evaluated in the cyclical program, taking account of the BUSY bits and the value returned in RET_VAL.

Tip

If you are using a Technology CPU, we recommend that you use SFB 54, rather than SFC 13 "DPNRM_DG".

- SFC 56 "WR_DPARM"; SFC 57 "PARM_MOD"

On CPUs 312 IFM to 318-2 DP, these SFCs always work "quasi-synchronously" during communication with centralized I/O modules and always work synchronously during communication with distributed I/O modules.

Note

If you are using SFC 56 "WR_DPARM" or SFC 57 "PARM_MOD", you should always evaluate the SFCs' BUSY bit.

SFC 20 "BLKMOV"

In the past, this SFC could be used with CPUs 312 IFM to 318-2 DP to copy data from a non runtime-related DB.

SFC 20 no longer has this functionality with the **Technology CPU** SFC 83 "READ_DBL" must now be used instead.

SFC 54 "RD_DPARM"

This SFC is no longer available on the **Technology CPU**. Use SFC 102 "RD_DPARA" instead, which works asynchronously.

SFCs that may return other results

You can ignore the following points if you only use logical addressing in your user program.

When using address conversion in your user program (SFC 5 "GADR_LGC", SFC 49 "LGC_GADR"), you must check the assignment of the slot and logical start address for your DP slaves.

- In the past, the diagnostic address of a DP slave was assigned to the slave's virtual slot 2. Since DPV1 was standardized, this diagnostic address has been assigned to virtual slot 0 (station proxy) for the **Technology CPU**
- If the slave has modeled a separate slot for the interface module (e.g. **Technology CPU** as an intelligent slave or IM 153), then its address is assigned to slot 2.

Activating / deactivating DP slaves via the SFC 12

With the **Technology CPU**, slaves that were deactivated via SFC 12 are no longer automatically activated at the RUN to STOP transition. Now they are not activated until they are restarted (STOP to RUN transition).

A.1.3 Interrupt events from distributed I/Os while the CPU status is in STOP

Interrupt events from distributed I/Os while the CPU status is in STOP

With the new DPV1 functionality (IEC 61158/ EN 50170, volume 2, PROFIBUS), the handling of incoming interrupt events from the distributed I/Os while the CPU status is in STOP has also changed.

Previous response by the CPU in the STOP state:

With CPUs 312 IFM to 318-2 DP, an interrupt event was initially noted while the CPU was in STOP mode. When the CPU status subsequently returned to RUN, the interrupt was then fetched by an appropriate OB (e.g. OB 82).

New response by the CPU:

With the **Technology CPU**, an interrupt event (process or diagnostic interrupt, new DPV1 interrupts) is acknowledged by the distributed I/O while the CPU is still in STOP status, and is entered in the diagnostic buffer if necessary (diagnostic interrupts only). When the CPU status subsequently returns to RUN, the interrupt is no longer fetched by the OB. Possible slave faults can be read using suitable SSL queries (e.g. read SSL 0x692 via SFC51).

A.1.4 Runtimes that change while the program is running

Runtimes that change while the program is running

If you have created a user program that has been fine-tuned in relation to certain processing times, please note the following points if you are using a **Technology CPU**:

- The program will run much faster on the **Technology CPU**.
- Functions that require MMC access (e.g. system start-up time, program download in RUN, return of DP station, etc), may sometimes run slower on the **Technology CPU**.

A.1.5 Converting the diagnostic addresses of DP slaves

Converting the diagnostic addresses of DP slaves

If you are using a **Technology CPU** as the master, please note that you may have to reassign the diagnostic addresses for the slaves since the changes to the DPV1 standard sometimes require two diagnostic addresses per slave.

- The virtual slot 0 has its own address (diagnostic address of the station proxy). The module status data for this slot (read SSL 0xD91 with SFC 51 "RDSYSST") contains IDs that relate to the entire slave/station, e.g. the "station error ID". Failure and restoration of the station are also signaled in OB 86 on the master via the diagnostic address of the virtual slot 0.
- The interface module is also modeled as a separate, virtual slot for some slaves (e.g. CPU as intelligent slave or IM 153) in which case it is assigned to virtual slot 2 with a separate address.
When the **Technology CPU** is used as an intelligent slave, for example, the operating status change is signaled in diagnostic interrupt OB 82 of the master via this address.

Note

Reading diagnostics data with SFC 13 "DPNRM_DG":

The originally assigned diagnostics address still works. Internally, *STEP 7* assigns this address to slot 0.

When using SFC51 "RDSYSST", for example, to read module status information or module rack/station status information, you must also consider the change in slot significance as well as the additional slot 0.

A.1.6 Reusing existing hardware configurations

Reusing existing hardware configurations

If you reuse the configuration of a CPU 312 IFM to 318-2 DP for a **Technology CPU**, the CPU may not run correctly.

If this is the case, you will have to replace the CPU in the STEP 7 hardware configuration editor. When you replace the CPU, STEP 7 will automatically accept all the settings (if appropriate and possible).

A.1.7 Replacement of a Technology CPU

Replacement of a Technology CPU

The Technology CPU is supplied with a connector inserted in the power supply port.

You do not need to disconnect the cables of the CPU when you replace a Technology CPU: Insert a screwdriver with 3.5 mm blade into the right side of the connector to open the interlock mechanism, then unplug it from the CPU. Once you have replaced the CPU, simply plug the connecting plug back into the power supply connector.

A.1.8 Using consistent data areas in the process image of a DP slave system

Consistent data

The table below illustrates the points to consider with respect to communication in a **DP master system** if you want to transfer I/O areas with "Total length" consistency. You can transfer a maximum of 128 bytes of consistent data.

Table A-1 Consistent data

| CPU 315-2 DP (as of firmware 2.0.0), CPU 317, CPU 319 CPU 31xC | CPU 315-2 DP (as of firmware 1.0.0), CPU 316-2 DP, CPU 318-2 DP (firmware < 3.0) | CPU 318-2 DP (firmware >= 3.0) |
|---|---|--|
| The address area of consistent data in the process image is automatically updated. | Even if it exist in the process image, consistent data is not automatically updated. | You can choose whether or not to update the address area of consistent data in the process image. |
| In order to read and write consistent data you can also use the SFCs 14 and 15 If the address area of consistent data is outside the process image, you have to use the SFCs 14 and 15 to read and write consistent data. Direct access to consistent areas is also possible (e.g. L PEW or T PAW). | To read and write consistent data, you must use SFC14 and 15. | To read and write consistent data, you can also use SFC 14 and SFC 15. If the address area of consistent data is not in the process image, you must use SFC 14 and SFC 15 to read and write consistent data. Direct access to consistent areas is also possible (e.g. L PEW or T PAW): |

A.1.9 Load memory design for the Technology CPU

Load memory design for the Technology CPU

On CPUs 312 IFM to 318-2 DP, the load memory is integrated into the CPU and may be extended with a memory card,

The load memory of the **Technology CPU** is located on the Micro Memory Card (MMC). and is retentive. When blocks are downloaded to the CPU, they are stored on the MMC and cannot be lost even in the event of a power failure or memory reset.

Note

User programs can only be downloaded and thus the CPU can only be used if the MMC is inserted.

A.1.10 PG/OP functions

PG/OP functions

With CPUs 315-2 DP (6ES7315-2AFx3-0AB0), 316-2DP and 318-2 DP, PG/OP functions at the DP interface were only possible if the interface was set to active. With CPUs 31xC/31x, these functions are possible at both active and passive interfaces. The performance of the passive interface is considerably lower, however.

A.1.11 Routing for the CPU 31xC/31x as an intelligent slave

Routing for the CPU 31xC/31x as an intelligent slave

If you use the CPU 31xC/31x as an intelligent slave, the routing function can only be used with an actively-configured DP interface.

In the properties of the DP interface in STEP 7, select the "Test, Commissioning, Routing" check box of the "DP-Slave" option.

A.1.12 Altered retentive response with a Technology CPU

Altered retentive response with a Technology CPU

With data blocks for the **Technology CPU**

- you can set the retentive response in the block properties of the DB.
- Using SFC 82 "CREA_DBL" -> Parameter ATTRIB, NON_RETAIN bit, you can specify if the actual values of a DB should be maintained at POWER OFF/ON or STOP-RUN (retentive DB) or if the start values should be read from the load memory (non-retentive DB).

A.1.13 FMs/CPs with their own MPI address in a Technology CPU central configuration

FMs/CPs with their own MPI address in a Technology CPU central configuration

Table A-2 Behavior of FMs/CPs with their own MPI address

| All CPUs apart from CPU 315-2 PN/DP, CPU 315T- 2 DP, CPU 317, CPU 318-2 DP and CPU 319-3 PN/DP | CPU 315-2 PN/DP, CPU 315T-2 DP, CPU 317 ,CPU 318-2 DP and CPU 319-3 PN/DP |
|---|--|
| If there are FMs/CPs with their own MPI address in the central rack of an S7-300, then they are in the exact same CPU subnet as the CPU MPI stations. | If there are FMs/CPs with their own MPI address in the central rack of an S7-300, then the CPU forms its own communication bus via the backplane bus with these FMs/CPs, which are separated from the other subnets. The MPI address of such an FM/CP is no longer relevant for the stations on other subnets. The communication to the FM/CP is made via the MPI address of the CPU. |

When you replace your existing CPU with a Technology CPU, therefore,

- you must replace the existing CPU by the Technology CPU in the STEP 7 project,
- Reconfigure the OPs. you must re-assign the control and the destination address (= the MPI address of the Technology CPU and the slot of the respective FM)
- Reconfigure the project data for FM/CP to be loaded to the CPU.

This is necessary to ensure that the FM/CP can still be "addressed" by the OP/PG in this rack.

Glossary

ACCU

Accumulators represent CPU register and are used as buffer memory for download, transfer, comparison, calculation and conversion operations.

Address

An address represents the identifier of a specific operand or operand range. Examples: input I 12.1; flag word MW 25; data block DB 3.

Analog module

Analog modules convert analog process values (for example, temperature) into digital values that can be processed by the CPU, or convert digital values into analog manipulated variables.

Automation system

An automation system is a programmable controller for SIMATIC S7.

Back-up memory

The backup memory ensures buffering of the memory areas of a CPU without backup battery. It backs up a configurable number of timers, counters, flags and data bytes, the retentive timers, counters, flags and data bytes.

Baud rate

Speed of the data transmission (bps)

Bus

A transfer medium that interconnects several nodes. Data can be transferred via serial or parallel circuits, that is, via electrical or fiber optic conductors.

Bus segment

Self-contained part of a bus system. Bus segments are interconnected by way of repeaters, for example, in PROFIBUS DP.

Clock flag

Flag which can be used to generate clock pulses in the user program (1 flag byte).

Note

When operating with S7-300 CPUs, make sure that the clock flag byte is not overwritten in the user program!

Code block

A SIMATIC S7 code block contains elements of the STEP 7 user program. (In contrast to a data block: This contains only data.)

Cold restart

On CPU startup (e.g. after it is switched from STOP to RUN via the mode selector or with POWER ON), OB100 (restart) is initially executed, prior to cyclic program execution (OB1). On restart, the process input image is read in and the STEP 7 user program is executed, starting at the first command in OB1.

Configuration

Assignment of modules to racks/slots and (for example with signal modules) addresses.

Consistent data

Data that belongs together in terms of its content and must not be separated is designated as consistent data.

As an example, the values of analog modules must always be treated as consistent data; i.e. the value of an analog module must not be corrupted by reading it out at two different times.

Counters

Counters are part of CPU system memory. The content of "counter cells" can be modified by STEP 7 statements (for example, up/down count.)

CPU

Central processing unit = CPU of the S7 automation system with a control and arithmetic unit, memory, operating system, and interface for the programming device.

Cycle time

The cycle time represents the time a CPU requires for one execution of the user program.

Cyclic interrupt

→ interrupt, cyclic interrupt

Data block

Data blocks (DB) are data areas in the user program and contain the user data. There are global data blocks which can be accessed by all code blocks, and instance data blocks which are assigned to a specific FB call.

Data, static

Static data are data that are used only within a function block. These data are stored in an instance data block belonging to the function block. Data stored in an instance data block are retained until the next function block call.

Data, temporary

Temporary data represent local data of a block. They are stored in the L-stack when the block is executed. After the block has been processed, these data are no longer available.

Diagnostic interrupt

Modules capable of diagnostics report detected system errors to the CPU by means of diagnostic interrupts.

Diagnostics

System diagnostics

Diagnostics buffer

The diagnostics buffer is a buffered memory area in the CPU. It stores diagnostic events in the order of their occurrence.

DP master

A master which behaves in accordance with EN 50170, Part 3 is known as a DP master.

DP slave

A slave operated on the PROFIBUS with PROFIBUS DP protocol and which behaves in accordance with EN 50170, Part 3 is referred to as DP slave.

DP(DRIVE)

PROFIBUS interface that is controlled by the integrated technology of the CPU isochronously (and therefore also equidistant).

DPV1

The designation DPV1 means extension of the functionality of the acyclical services (to include new interrupts, for example) provided by the DP protocol. The DPV1 functionality is integrated in IEC 61158 / EN 50170, Volume 2, PROFIBUS.

Engineering station

PC workplace, at which configuration work is performed on a control system.

Error display

One of the possible reactions of the operating system to a runtime error is to output an error message. The other possible reactions include: Error reaction in the user program, CPU in STOP.

Error handling via OB

After the operating system has detected a specific error (e.g. an access error with STEP 7), it calls a dedicated organization block (error OB) in which the subsequent behavior of the CPU can be defined.

Error reaction

Reaction to a runtime error. The operating system can react in the following ways: It sets the automation system to STOP, indicates the error, or calls an OB in which the user can program a reaction.

Execution level

Execution levels form the interface between the operating system of the CPU and the user program. The sequence for executing the blocks of the user program is specified in the execution levels.

Flag

Flags are part of the CPU's system memory. They store intermediate results of calculations. They can be accessed in bit, byte, word or double word operations.

Force

The force function can be used to assign fixed values to specific variables of a user program or CPU (also: inputs and outputs).

In this context, please note the limitations listed in the *Overview of the test functions section in the Test Functions, Diagnostics and Troubleshooting chapter in the S7-300 Installation manual.*

Function

According to IEC 1131-3, a function (FC) is a code block without static data. A function allows transfer of parameters in a user program. Functions are therefore suitable for programming frequently occurring complex functions, e.g. calculations.

Function block

According to IEC 1131-3, a function block (FB) is a code block with static data. An FB enables the transfer of parameters in the user program. Function blocks are therefore suitable for programming frequently occurring complex functions, e.g. controls, mode selections.

GD circuit

A GD circuit comprises a number of CPUs sharing data by means of global data communication, and is used as follows:

- A CPU sends a GD packet to the other CPUs.
- A CPU sends and receives a GD packet from another CPU.

A GD circuit is identified by a GD circuit number.

GD element

A GD element is generated by assigning shared global data. It is identified by a unique global data ID in the global data table.

GD packet

A GD packet can consist of one or more GD elements transmitted in a single message frame.

Global data

Global data can be addressed from any code block (FC, FB, OB). In particular, this refers to bit memory M, inputs I, outputs Q, timers, counters and data blocks DB. Global data can be accessed either absolutely or symbolically.

Global data communication

Global data communication is a method of transferring global data between CPUs (without CFBs).

GSD file

The device data file (GSD file) contains all slave-specific properties. The format of GSD files is specified in EN 50170, Volume 2, PROFIBUS.

Instance data block

The STEP 7 user program assigns an automatically generated DB to every call of a function block. The instance data block stores the values of input, output and in/out parameters, as well as local block data.

Integrated inputs/outputs for integrated technology

The Technology CPU has 4 digital inputs and 8 digital outputs integrated. You use these inputs and outputs for technology functions, e.g. reference point acquisition (BERO) or high-speed output cam switching signals. The integrated inputs and outputs can also be used with technology functions in the *STEP 7* user program.

Integrated technology

In addition to the standard PLC functions, the Technology CPU has been expanded with integrated technology functions. The operating system of the Technology CPU has also been expanded in order to guarantee fast processing times for these technology functions.

Intelligent DP slave

Signal preprocessing field device. One of its features is that the input/output range provided for the DP master does not correspond to an actually existing I/O, but an input/output range that is mapped by a preprocessing CPU.

Interrupt

The CPU's operating system knows different priority classes for controlling user program execution. These priority classes include interrupts, e.g. process interrupts. When an interrupt is triggered, the operating system automatically calls an assigned OB. In this OB the user can program the desired response (e.g. in an FB).

Interrupt, cyclic interrupt

A cyclic interrupt is generated periodically by the CPU in a configurable time pattern. A corresponding OB will be processed.

See also Organization Block

Interrupt, delay

The time-delay interrupt belongs to one of the priority classes in SIMATIC S7 program processing. It is generated on expiration of a time started in the user program. A corresponding OB will be processed.

Interrupt, diagnostic

→ diagnostics interrupt

Interrupt, process

→ process interrupt

Interrupt, status

A status interrupt can be generated by a DPV1 slave and causes OB 55 to be called on the DPV1 master. For detailed information on OB 55, see the *Reference Manual System software for S7-300/400: System and Standard Functions*.

Interrupt, time-of-day

The time-of-day interrupt is one of the priority classes in SIMATIC S7 program processing. SIMATIC S7. It is generated at a specific date (or daily) and time-of-day (e.g. 9:50 or hourly, or every minute). A corresponding OB will be processed.

Interrupt, update

An update interrupt can be generated by a DPV1 slave and causes OB56 to be called on the DPV1 master. For detailed information on OB56, see the *Reference Manual System software for S7-300/400: System and Standard Functions*.

Interrupt, vendor-specific

A vendor-specific interrupt can be generated by a DPV1 slave. It causes OB57 to be called on the DPV1 master.

For detailed information on OB 57, refer to the *Reference Manual System Software for S7-300/400: System and Standard Functions*.

Load memory

Load memory is part of the CPU. It contains objects generated by the programming device. It can be implemented either as a plug-in memory card or as integrated memory.

Local data

Data, temporary

Master

When a master is in possession of the token, it can send data to other nodes and request data from other nodes (= active node).

Micro memory card

Micro memory cards are memory media for CPUs and CPs. When compared with a → memory card, a Micro Memory Card is smaller.

Module parameter

Module parameters are values with which the behavior of the module can be set. A distinction is made between static and dynamic module parameters.

MPI

The multi-point interface (MPI) is the SIMATIC S7 interface for programming devices. It allows simultaneous operation of several nodes (programming devices, text displays, operator panels) on one or more CPUs. Each node is identified by a unique address (MPI address).

Nesting depth

Using block calls, one block can be called from within another. Nesting depth is referred to as the number of simultaneously called code blocks.

OB priority

The CPU operating system distinguishes between different priority classes, for example, cyclic program execution, process interrupt controlled program processing. Each priority class is assigned organization blocks (OBs) in which the S7 user can program a response. Per default, OBs have different priorities and they are processed and interrupt each other according to their priority classes.

Operating mode

SIMATIC S7 automation systems know the following operating modes: STOP, STARTUP, RUN.

Operating system

The operating system of the CPU organizes all the functions and processes of the CPU that are not connected to a special control task.

→ CPU

Organization block

Organization blocks (OBs) form the interface between CPU operating system and the user program. The sequence for executing the user program is specified in the organization blocks.

Parameters

1. Variable of a STEP 7 code block
2. Variable for setting the response of a module (one or several per module). As delivered, each module has an appropriate default setting that can be changed via configuration in STEP 7. The parameters are divided into static and dynamic parameters.

Parameters, dynamic

In contrast to static parameters, the dynamic parameters of modules can be changed during operation by calling an SFC in the user program, for example limit values of an analog signal input module.

Parameters, static

Unlike dynamic parameters, static parameters of modules cannot be changed by the user program. You can only modify these parameters by editing your configuration in STEP 7, for example, modification of the input delay parameters of a digital signal input module.

Priority class

The S7 CPU operating system provides up to 26 priority classes (or "Program execution levels"). Specific OBs are assigned to these classes. The priority classes determine which OBs interrupt other OBs. Multiple OBs of the same priority class do not interrupt each other. In this case, they are executed sequentially.

Process image

The process image is a component of the system memory of the CPU. At the start of the cyclic program the signal states of the input modules are transferred to the process input image. At the end of the cyclic program the process output image is transferred as a signal state to the output modules.

Process interrupt

A process interrupt is triggered by interrupt-triggering modules as a result of a specific event in the process. The process interrupt is signaled to the CPU. The assigned organization block will be processed according to interrupt priority.

PROFIBUS DP

Digital, analog and intelligent modules, as well as a wide range of field devices in accordance with EN 50170, Part 3, such as drives or valve terminals are moved to the local process by the automation system across distances of up to 23 km.

The modules and field devices are interconnected with the automation system via the PROFIBUS DP field bus and are addressed in the same way as the centralized I/O.

Programming device

Programming devices are essentially personal computers suitable for industry that have a compact design and can be transported. Their distinguishing feature is the special hardware and software for SIMATIC programmable logic controllers.

RAM

RAM (Random Access Memory) is a semiconductor read/write memory.

Reduction factor

The reduction factor determines the send/receive frequency for GD packets on the basis of the CPU cycle.

Reference ground

→ Ground

Reference potential

Voltages of participating circuits are referenced to this potential when they are viewed and/or measured.

Retentive address areas

A memory area is considered retentive if its contents are retained even after a power loss and transitions from STOP to RUN. The non-retentive area of the flags, timers and counters is reset following a power failure and a transition from the STOP mode to the RUN mode.

Retentive can be the:

- Flag
- S7 timers
- S7 counters
- Data areas

Revision level

Differentiates products of the same order number. The product version is incremented when forward-compatible functions are enhanced, after production-related modifications (use of new parts/components) and for bug fixes.

Runtime error

Errors that occur during execution of the user program on the automation system (in other words, not in the process).

S7T Config

With S7T Config you configure the technology objects required to implement your motion control task. The STARTER for the drives from the MICROMASTER and SINAMICS families is integrated in S7T Config.

Segment

→ Bus segment

Shutdown

What happens during shutdown?

1. The control of the Technology CPU is already in STOP mode during shutdown. The outputs of the centralized and distributed I/Os are deactivated.
2. The integrated inputs/outputs for integrated technology and the ET 200M on the DP(DRIVE) are still active during shutdown.
3. The integrated technology of the Technology CPU shuts down the drives on the PROFIBUS DP(DRIVE) in a controlled manner.
4. The integrated technology of the CPU then also goes into STOP. The integrated inputs/outputs for integrated technology and the ET 200M on the DP(DRIVE) are deactivated.

The maximum duration of shutdown depends on your configuration in S7T Config.

Signal module

Signal modules (SMs) form the interface between the process and the automation system. There are digital input and output modules (input/output module, digital) and analog input and output modules (input/output module, analog).

Signal status list

The system status list contains data that describes the current status of an S7-300. You can always use this list to obtain an overview of:

- The configuration of the S7-300
- The current CPU configuration and configurable signal modules
- The current states and processes in the CPU and in configurable signal modules.

Slave

A slave can only exchange data with a master after being requested to do so by the master.

STARTUP

The STARTUP mode is executed at the transition from STOP to RUN mode. It can be triggered by means of the mode selector switch, or after power on, or by an operator action on the programming device. An S7-300 performs a restart.

STEP 7

Programming software for the creation of user programs for SIMATIC S7 controllers.

Substitute value

Substitute values are parameterizable values which output modules transfer to the process when the CPU switches to STOP mode.

In the event of an I/O access error, a substitute value can be written to the accumulator instead of the input value which could not be read (SFC 44).

System diagnostics

System diagnostics is the detection, evaluation, and indication of faults/errors which occur within the automation system. Examples of such error/faults are program errors or failures on modules. System errors can be indicated by LEDs or in STEP 7.

System function

A system function (SFC) is a function integrated in the operating system of the CPU that can be called when necessary in the STEP 7 user program.

System function block

A system function block (SFB) is a function block integrated in the operating system of the CPU that can be called when necessary in the STEP 7 user program.

System memory

System memory is an integrated RAM memory in the CPU. System memory contains the address areas (e.g. timers, counters, flags) and data areas that are required internally by the operating system (for example, communication buffers).

Technology configuration data

The configuration that you have created with *STEP 7* is stored in the technology configuration data.

Technology data block

The integrated technology provides current information on the status and on the values of the technology objects via the technology data blocks.

Technology objects

Technology objects are the logical representation of axes, output cams, measuring inputs, cams and external encoders, with which the drive components can be controlled. The technology objects configured with the *SIMATIC S7-Technology* option package contain definitions for the physical properties of the mechanical system, for limits, monitoring and control.

Technology system data

Technology system data are the data of the technology objects, such as drive axis, output cam, ...

Terminator

The terminating resistor is used to avoid reflections on data links.

Time-delay interrupt

→ interrupt, delay

Time-of-day interrupt

Interrupt, time-of-day

Timer

Timers

Timers

Timers are part of CPU system memory. The content of "timer cells" is automatically updated by the operating system, asynchronously to the user program. STEP 7 statements are used to define the precise function of the timer cell (for example, ON delay) and to initiate their execution (for example, start).

User memory

The user memory contains the code blocks and data blocks of the user program. User memory can be integrated in the CPU, or stored on plug-in memory cards or memory modules. However, the user program is principally processed from the work memory of the CPU.

User program

In SIMATIC, a distinction is made between the operating system of the CPU and user programs. The user program contains all the instructions, declarations and data for signal processing required to control a plant or a process. It is assigned to a programmable module (for example CPU or FM) and can be structured in smaller units (blocks).

→ operating system

→ STEP 7

Work memory

The work memory is integrated in the CPU and cannot be extended. It is used to run the code and process user program data. Programs run exclusively in work memory and system memory.

Index

5

5 VDC, 15, 21

A

Activation/deactivation, 116

Addressing, 19

ADI4

Analog drive interface, 29

Alarm event, 117

Analog drive interface

ADI4, 29

Analog drives, 29

Application

in industrial environments, 95

in residential areas, 95

Approval

CE, 92

CSA, 93

FM, 94

Marine, 94

UL, 92

Approvals, 4

Standards, 92

Area of application, 9

Assignment

S7 connection, 39

Availability

S7 connection, 41

Axis configurations, 9

B

basic knowledge

required, 3

Basic knowledge

Required, 3

BF1, 15, 22

BF3, 15, 22

Blocks

Load, 55

Upload, 57

Breakpoints, 21

Burst pulses, 96

Bus fault, 22

BUSF

LED, 22

BUSF1

LED, 22

C

CE

Approval, 92

Central processing unit, 17

Code block, 45

COMBIMASTER, 11, 29

Commissioning, 20

Communication, 25

Data consistency, 37

S7 communication, 33

Communication Load

configured, 74

Dependency of physical cycle time, 75

Influence on the physical cycle time, 75

Communication path

S7 connection, 38

Communication services, 30

Communication variable, 37

Compression, 58

Configuration, 17

S7 communication, 38

single-tier, 11

Configuration data, 45

Technology, 47

Configuring, 11

Connectable devices, 29

PROFIBUS DP, 28

Connection

Voltage supply, 15

Connection point, 38

Continuous shock, 100

Control, 19

Control tasks, 9

Counters, 46

CPU
 Elements, 13
 Operating system, 20
CPU memory reset, 58
CSA
 Approval, 93
Cycle time
 Calculation, 70
 Definition, 68
 Extension, 70
 Maximum Cycle Time, 73
 Process image, 68
 Sample calculation, 85
 Sequence of cyclic program processing, 69
 Time-Sharing Model, 68
Cyclic interrupt, 84

D

Data block (DB), 45
 Non-retentive, 46
 Retentive, 46
 Retentive behavior, 48
Data consistency, 37
Definition
 Electromagnetic Compatibility, 96
Degree of protection IP 20, 101
Delay interrupt, 84
Devices
 connectable, 28, 29
 non-connectable, 30
Diagnosis
 Address, 118
Diagnostics, 29
 DP(DRIVE), 30
Dimension drawing, 102
Distribution
 S7 connection, 40
DP interface error, 22
DP(DRIVE)
 Diagnostics, 30
 OP, 18
 Programming device, 18
DP(DRIVE) interface, 11
DPV1, 42
Drive interface
 analog, 29

E

Electromagnetic Compatibility, 96

Electrostatic discharge, 96
Elements
 CPU, 13
EMC, 96
Emission of radio interference, 97
Error display, 15, 21
 DP-capable CPUs, 22
ET 200M, 29

F

Field of application, 9
Fields of application, 9
Flag, 46
FM
 Approval, 94
Force function, 21
FRCE, 15, 21

G

GD circuit, 34
GD packet, 34
General technical specifications, 92
Global data communication, 31, 33

H

Hardware catalog, 29
Hardware configuration
 reuse, 118
Hardware interrupt
 Response time, 37

I

Identification code for Australia, 94
IEC 61131, 94
IM 174 interface for analog drives and stepper motors, 29
Indicators, 13
Information
 SFCs, 115
Inputs and outputs for technology
 integrated, 11, 14, 19
 Integrated, 11
Insulation test, 101
Integrated inputs and outputs for technology, 11, 14, 19
Integrated Inputs/Outputs for Technology
 Layout, 113, 114

Integrated technology, 19
 Interface, 10, 25
 Interrupt response time
 Calculation, 83
 Definition, 83
 Of signal modules, 84
 Of the CPUs, 83
 Process interrupt processing, 84
 Sample calculation, 88
 Isochronism, 18
 Isochronous mode, 11, 13, 29

J

Job data compartment, 63

L

Layout
 Integrated Inputs/Outputs for Technology, 113, 114
 Memory, 45
 LED, 21, 22
 Display, 15
 Load
 of blocks, 55
 Load memory, 45
 Size, 45
 Load memory design
 Technology-CPU, 120
 Local data, 46, 53
 Longest response time
 Calculation, 80
 Conditions, 80

M

Manual
 Purpose, 3
 Scope, 3
 Marine
 Approval, 94
 MASTERDRIVES, 29
 Maximum Cycle Time, 73
 Mechanical environmental conditions, 99
 Memory
 Compression, 58
 Layout, 45
 Retentive, 47
 Memory area, 45
 Memory concept, 45

Memory functions
 Compression, 58
 Download of blocks, 55
 Promming, 58
 RAM to ROM, 58
 Uploading blocks, 57
 Memory module, 14
 Memory objects
 Retentive behavior, 48
 Micro memory card
 Micro memory card, 54
 Micro Memory Card - Useful life, 55
 Micro memory card (MMC), 45
 Slot, 14
 Technical specifications, 91
 MICROMASTER, 11
 MICROMASTER 4, 29
 Migration
 Technology CPU, 115
 Mode selector switch, 15
 Module
 Start address, 19
 Motion control, 9
 Motion Control, 9
 Motion tasks, 9
 MPI, 19
 Properties, 27
 MPI / DP interface, 10, 25, 26
 MPI interface
 Time synchronization, 28
 MRES, 15

N

Network gateway, 35
 Non-connectable devices, 30
 Non-retentive data block, 46
 Number of nodes, 19

O

OP
 on DP(DRIVE), 18
 OP communication, 31, 32
 Operand area, 46, 50
 Operating mode, 15
 Operating system, 20
 Of the CPU, 20
 Technology, 20
 updating, 20
 Operator controls, 13

Optional package
 S7-Technology, 20

P

PG
 on DP(DRIVE), 18
 PG communication, 31
 PLCopen, 9
 Power supply, 17
 Process image, 46
 of inputs and outputs, 51
 Process interrupt
 Processing, 84
 Processing sequence
 Data block, 63, 64, 67
 PROFIBUS cable, 17
 PROFIBUS DP, 19
 Connectable devices, 28
 Properties, 27
 PROFIBUS DP (DRIVE), 19
 PROFIBUS DP(DRIVE), 25, 29
 PROFIdrive, 29
 Program execution
 Runtime, 117
 Programming, 11
 Programming device cable, 18
 Properties
 MPI, 27
 PROFIBUS DP, 27
 Protection class, 101
 Pulseshaped disturbance, 96
 Purpose
 Manual, 3
 PUT/GET function, 37

R

RAM to ROM, 58
 Reduction factor, 34
 Replacement of a Technology CPU, 119
 Required basic knowledge, 3
 Requirement
 Commissioning, 20
 Routing, 35
 Reservation
 S7 connection, 39

Response time
 Calculating the longest, 80
 Calculating the shortest, 79
 Conditions for the longest, 80
 Conditions for the shortest, 79
 Definition, 77
 DP cycle times, 78
 Factors, 77
 Reduction with direct I/O access, 81
 Sample calculation, 86
 Variation, 77
 Retentive address areas, 47
 Retentive behavior
 DB, 48, 49
 Memory objects, 48
 Technology data block, 48, 49
 Retentive data block, 46
 Retentive memory, 47
 reuse
 Hardware configurations, 118
 Routing, 34
 Access to stations on other subnets, 34
 Example of an application, 36
 PG functions, 31
 Requirements, 35
 RUN, 15, 21
 Runtime
 Program execution, 117

S

S7 basic communication, 31, 32
 S7 communication, 31, 33
 Configuration, 38
 S7 connection
 Assignment, 39
 Availability, 41
 Communication path, 38
 Distribution, 40
 Reservation, 39
 S7 connections
 Time sequence for allocation, 40
 S7T Config, 14
 S7-Technology, 11, 63
 Optional package, 20
 Sample calculation
 For the cycle time, 85
 Of interrupt response time, 88
 Of the response time, 86
 Scope
 Manual, 3
 SF, 15, 21

- SFC
 - Information, 115
 - Shipping conditions, 98
 - Shock, 100
 - Shortest response time
 - Calculation, 79
 - Conditions, 79
 - Shutdown, 16, 21
 - Signal module, 17
 - SIMATIC Micro Memory Card
 - Plug-in MMCs, 91
 - Properties, 54
 - SIMODRIVE, 11
 - SIMODRIVE 611 universal, 11, 29
 - SIMODRIVE POSMO, 29
 - SINAMICS, 29
 - Single-tier configuration, 11
 - Sinusoidal disturbance, 97
 - Size
 - Load memory, 45
 - Slot, 19
 - Micro memory card (MMC), 14
 - Standards and approvals, 92
 - Start address
 - Module, 19
 - Status display, 15, 21, 45
 - DP-capable CPUs, 22
 - Stepper, 29
 - Stepper motors, 29
 - STOP, 15, 21
 - Storage conditions, 98
 - Subnets, 18
 - support, 4
 - Support, 4
 - System memory, 46, 50
 - Local data, 53
 - Operand areas, 50
 - Process image of inputs/outputs, 51
- T**
- Technical specifications
 - Electromagnetic Compatibility, 96
 - Micro memory card (MMC), 91
 - Shipping and storage conditions, 98
 - Technological configurations, 9
 - Technological tasks, 9
 - Technology, 9
 - Configuration data, 47
 - Integrated inputs and outputs, 11, 14, 19
 - Operating system, 20
 - Technology CPU, 9
 - Technology CPU
 - Migration, 115
 - Technology, 9
 - Technology data block
 - Processing sequence, 63, 64, 65
 - Retentive behavior, 49
 - Technology DB
 - Retentive behavior, 48
 - Technology objects, 9
 - Technology system data, 45
 - Technology-CPU
 - Load memory design, 120
 - Temperature, 98
 - Test voltage, 101
 - TIA environment, 9
 - Time synchronization
 - MPI interface, 28
 - Timers, 46
 - Transition point, 38
 - Transmission rate, 18
- U**
- UL
 - Approval, 92
 - Updating
 - Operating system, 20
 - Upload, 57
 - Useful life of a Micro Memory Card, 55
 - User program
 - Upload, 57
- V**
- Vibration, 100
 - Voltage supply
 - Connection, 15
- W**
- Work memory, 46
- X**
- X1, 25, 26
 - X3, 25

