

# SIEMENS

[efesotomasyon.com](http://efesotomasyon.com)

## Micro System SIMATIC S7-200

Two Hour Primer

Edition 01/2000

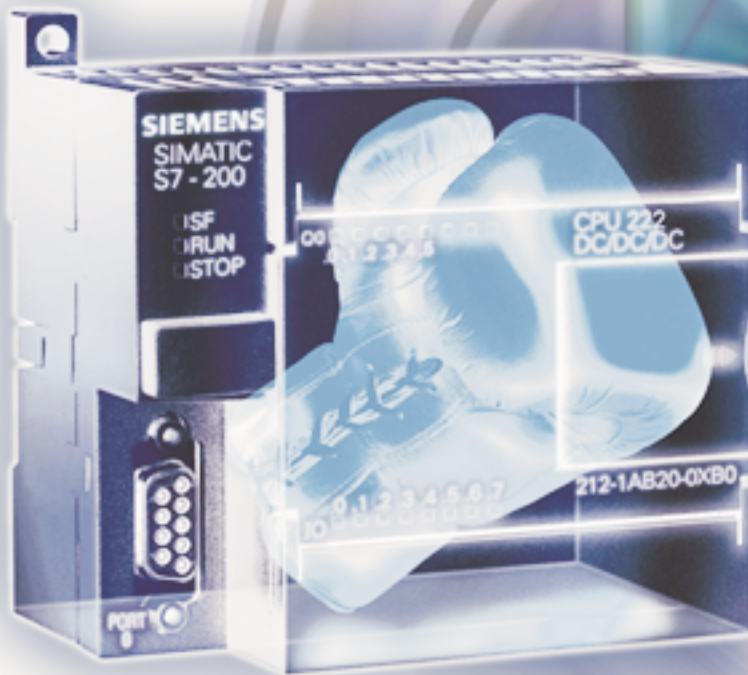

microsystems

**Safety Guidelines**

The Two Hour Primer was created as a quick introduction to the world of S7-200 and has deliberately been kept short. It is not a substitute for the S7-200 manual.

Therefore, please observe the instructions given in the S7-200 manual, especially the safety guidelines.

---

**Trademarks**

SIMATIC<sup>®</sup> and SIMATIC NET<sup>®</sup> are registered trademarks of Siemens AG.

Third parties using for their own purposes any other names in this document which refer to trademarks might infringe upon the rights of the trademark owners.

Copyright © Siemens AG 2000 All rights reserved

The reproduction, transmission or use of this document or its contents is not permitted without express written authority. Offenders will be liable for damages. All rights, including rights created by patent grant or registration of a utility model or design, are reserved.

Siemens AG  
Automation and Drives  
Industrial Automation Systems  
P.O. Box 4848, D-90327 Nuremberg  
Federal Republic of Germany

**Disclaimer of Liability**

We have checked the content of this manual for agreement with the hardware and software described. Since deviations cannot be precluded entirely, we cannot guarantee full agreement. However, the data in this manual are reviewed regularly and any necessary corrections included in subsequent editions. Suggestions for improvement are welcomed.

© Siemens AG 2000

Subject to change without prior notice

## Contents

Revision	A Few Words of Revision	5
	Here are the Bits	6
	Current Flow in the Ladder Diagram	7
	The PLC Cycle5	9
Latching	Introduction	13
	Normally-Closed (NC) Contact	14
	Solution Description and Test	16
	A Different Take on Latching...	17
Pulse-Operated Switch	Introduction	21
	Solution Overview	22
	Edge Detection	23
	Bit Memories	25
	Solution Description and Test	27
Off-Delay Timer	Introduction	29
	Save As...	31
	Insert Network	32
	Solution Description	33
	Enter Comments	36
Sequencer	Introduction	39
	Basics	41
	Working with Sequencers	45
	Modification	50
	Solution Description, Example	51
	Test	55
Appendix	Appendix	A1
	Index	B1



You will find this breakdown of the Two-Hour Primer in the footer of each page. The chapter you are currently in is highlighted in each case.

## Preface

Dear S7-200 user,

Efficiency in the use of micro controllers depends primarily on how quickly and safely you can learn to use a controller. We created the 1-and 2-hour primers so that even beginners can learn to handle the S7-200 quickly and easily.

Building on the 1-hour primer, this 2-hour primer will familiarize you in a short time with the principle of operation of the S7-200 controller. Using a few example tasks, the primer shows you how the controller operates and how it can be used effectively for simple tasks.

After working through the 2-hour primer, you will find it easy to solve typical controller tasks on your own.

Enjoy reading your primer!

You can load the examples mentioned above from the enclosed diskette.



The S7-200 team wishes  
you every success!

2

Revision



Latching



Pulse-Oper-  
ated Switch



Off-Delay  
Timer



Sequencer



Appendix

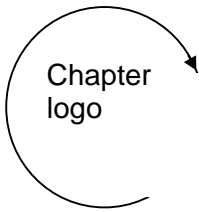

## Primer symbols

Certain symbols and text highlights are used frequently in the 2-hour primer. Their meanings are explained on this page.

Check out the page header first! Each page has an identical page header design. The blue heading in large letters indicates the current sub-header of the chapter. The area "New" in the right-hand side of the header shows the contents of the preceding pages with the contents of the current page highlighted in blue followed by the contents of the following page(s).

*Text on a gray background prompts you to some action such as an input.*



This symbol shows you that the left mouse key must be clicked once for an action (e.g. mark field).



2 x

This symbol shows you that the left mouse key must be double-clicked for an action.



Here you are prompted to press the ENTER (or RETURN) key on your keyboard.



This indicates that you can select list points provided onscreen using the mouse or optionally the keyboard (function keys, arrow keys).

F2

This means you must press function key "F2" (function keys F1 ... F12 are available). You will discover that, despite user-friendly mouse operation, you can work faster with the keyboard in certain cases.



In combination with a page reference, you will find here further details on a specific topic.



At these points, you will be requested to make entries in text fields on the screen, or you will be reminded that in your own projects you should make notes here.



Menu

A menu point on the screen is activated step-by-step (heading, sub-heading) with the left mouse key.

4

Revision



Latching



Pulse-Operated Switch



Off-Delay  
Timer



Sequencer



Appendix

- A Few Words of Revision
- Here are the Bits
- Current Flow in the Ladder Diagram
- The PLC Cycle



## A Few Words of Revision ...

In the 1-hour primer, you saw that the circuit diagram for contactor controllers is related to the ladder diagram for programming programmable controllers.

It is simply a representation with other symbols.

In addition, you were already able to program small logic operations yourself. You even learned to recognize timers in that short time.



Compare with Page 24 in the 1-hour primer

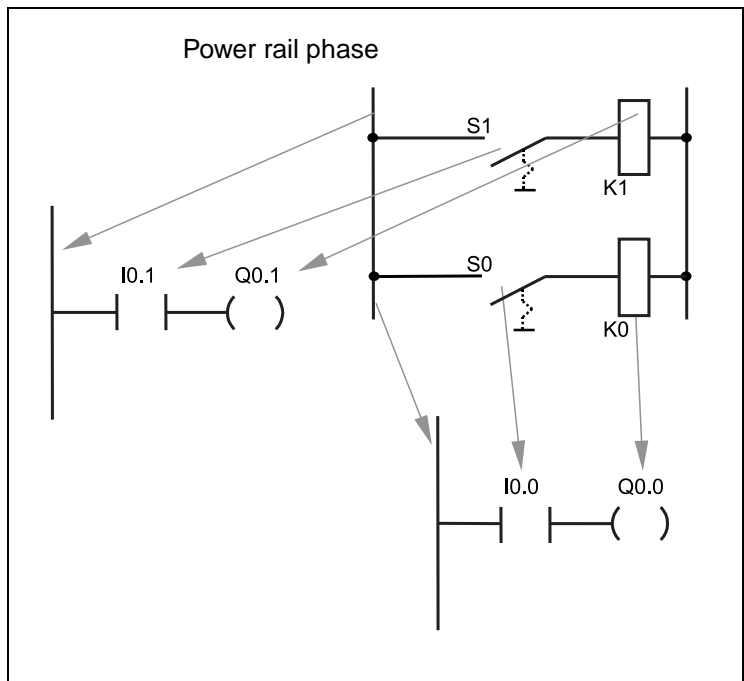

- A Few Words of Revision
- **Here are the Bits**
- Current Flow in the Ladder Diagram
- The PLC Cycle



## Here are the Bits

The smallest unit to be processed is the bit!

The bit can assume two states:

- 1) "1" meaning "bit set" or state is "true",
- 2) "0" meaning "bit not set" or state is "untrue",

In a method familiar to you, the two binary states "1" and "0" can be represented as electrical circuits, that is, they can be represented by switches.

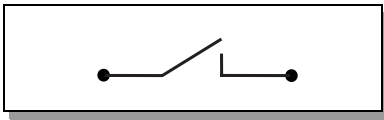

A closed switch:

Current flows so bit state = "1"

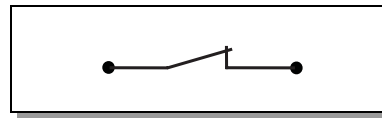

"1" = "true" =  
Current flows

and an open switch:

No current flows so bit state = "0".

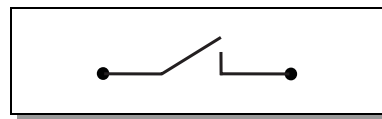

"0" = "untrue" =  
No current  
flows

From here it requires only a short step to the representation of logic operations as circuits, e.g. series connection of two contacts.

The AND operation of inputs I0.0 and I0.1 is represented as shown on the right.

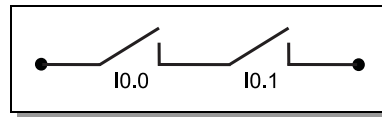

AND operation

This is represented as follows in LAD:

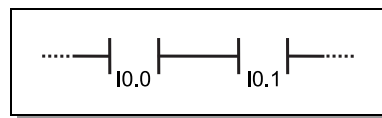

Finally, a small convention.

The following applies for positive logic:

24V = high-level = "1" und

0V = low-level = "0".

positive logic

The following applies for negative logic:

0V = low-level = "1"

24V = high-level = "0".

negative logic

- A Few Words of Revision
- Here are the Bits
- Current Flow in the Ladder Diagram
- The PLC Cycle



## Current Flow in the Ladder Diagram (1)

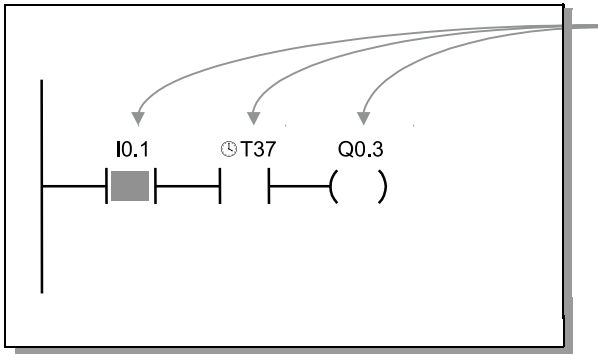

In this example, output Q0.3 is active or "1", if the contact at I0.1 is closed, i.e. "1" (24 V DC at input I0.1) AND simultaneously, the timer bit T37 is active, i.e. "1".

Input I0.1 is now "1", i.e. contact I0.1 is closed. T37 is not active in the figure, i.e. it is "0". For this reason, Q0.3 remains inactive, i.e. "0".

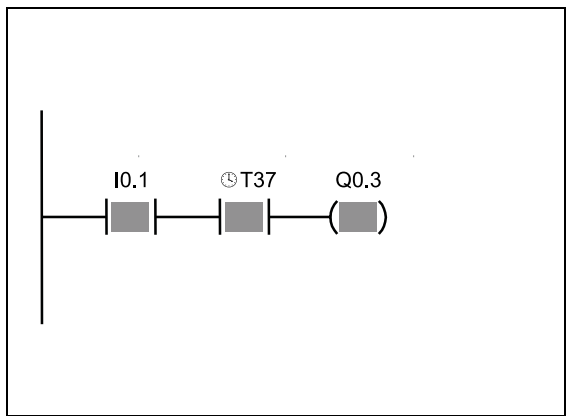

If timer T37 is also "1" (T37 has elapsed), the result of the AND operation is "1" and so output Q0.3 is also "1".

The output bit is then also "true", in other words, it takes the value "1" (gray background).

This corresponds to the LAD status view that you have already used in the 1-hour primer for debugging your program.

- A Few Words of Revision
- Here are the Bits
- Current Flow in the Ladder Diagram
- The PLC Cycle



## Current Flow in the Ladder Diagram (2) (Using the Help Function)

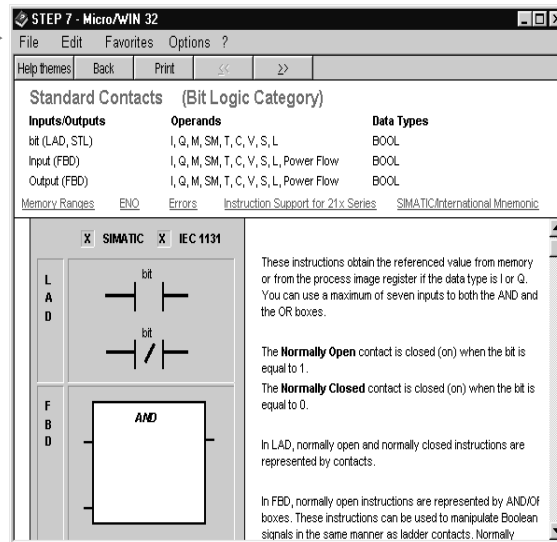
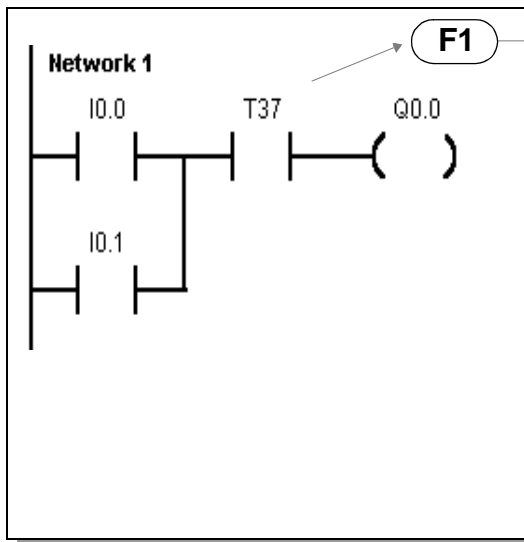

Help displays

1. Mark element

2. F1

If you want to see again the on-line help for a contact symbol or for other functions:

Mark the contact:

- in the Ladder Diagram (LAD) or
- in the Function Block Diagram (FBD) resp.
- mark the contact in your STEP 7-Micro/WIN ladder diagram

with a simple click of the mouse and then press F1.

F1 On-line-help



- A Few Words of Revision
- Here are the Bits
- Current Flow in the Ladder Diagram
- The PLC Cycle



## The PLC Cycle (1)

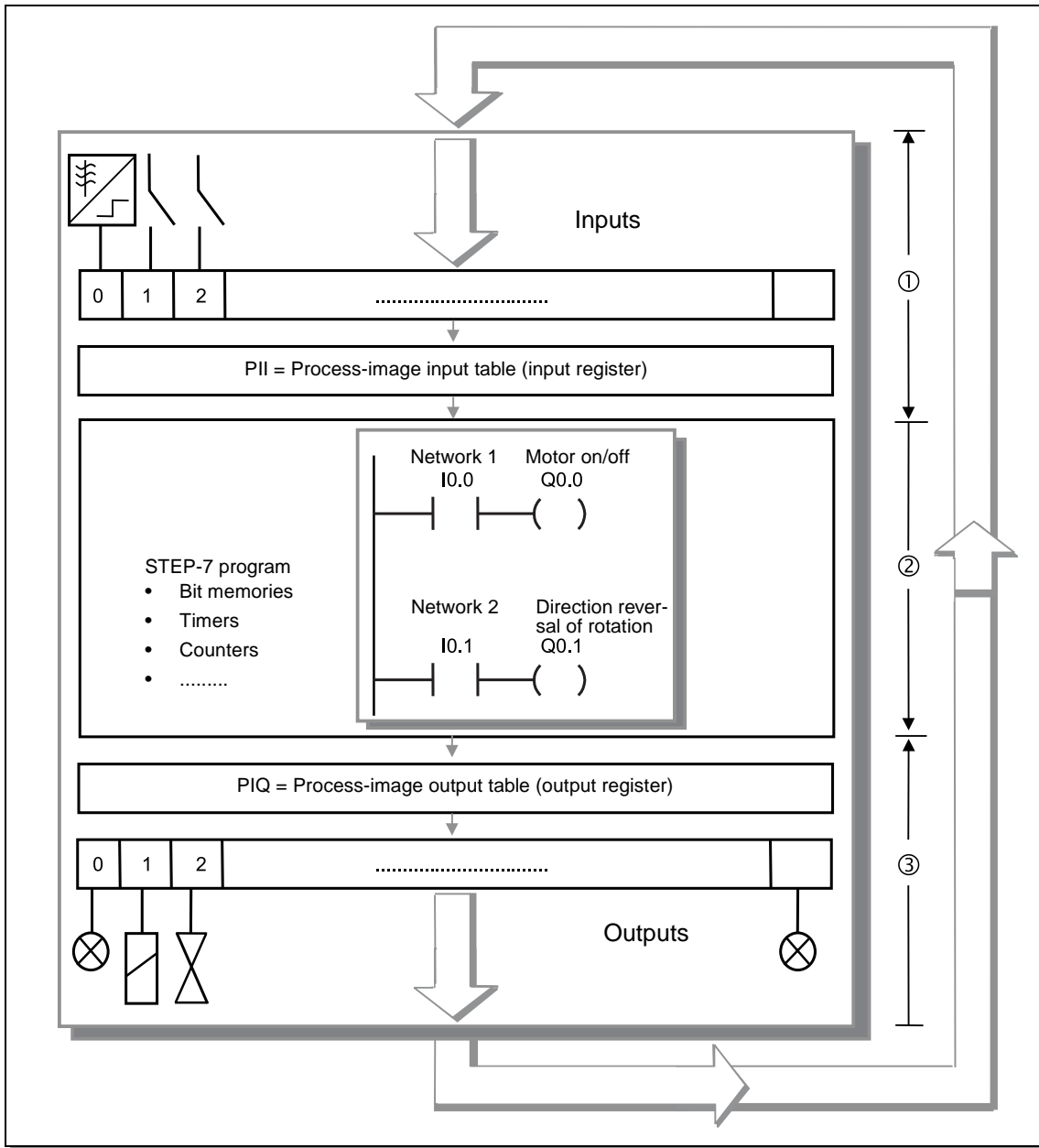

All SIMATIC programmable controllers usually work in a cyclical manner. In this cyclical operation the switch statuses are read at the inputs and stored in the process input image (PII). This information is subsequently used to feed and process the control program.

Process Input Image: PII

- A Few Words of Revision
- Here are the Bits
- Current Flow in the Ladder Diagram
- The PLC Cycle



## The PLC Cycle (2)

The outputs in the process-image output table (PIQ) are overwritten in accordance with the switching logic in the program. The statuses in the PIQ are transferred to the physical outputs in the final step. The cycle then begins again from the start.

Process-image  
output table:  
PIQ

A typical cycle takes between 3 and 10 ms. The duration depends on the number and type of the statements used.

The cycle consists of two main components:

- 1) Operating system time, typ. 1 ms; corresponding to phase ① and ③ Page 9.
- 2) Time for processing the commands; corresponding to phases ②, Page 9.

In addition, cycles are only processed when the PLC is operating, in other words, it is in the "RUN" operating state.



- A Few Words of Revision
- Here are the Bits
- Current Flow in the Ladder Diagram
- The PLC Cycle



## The PLC Cycle (3)

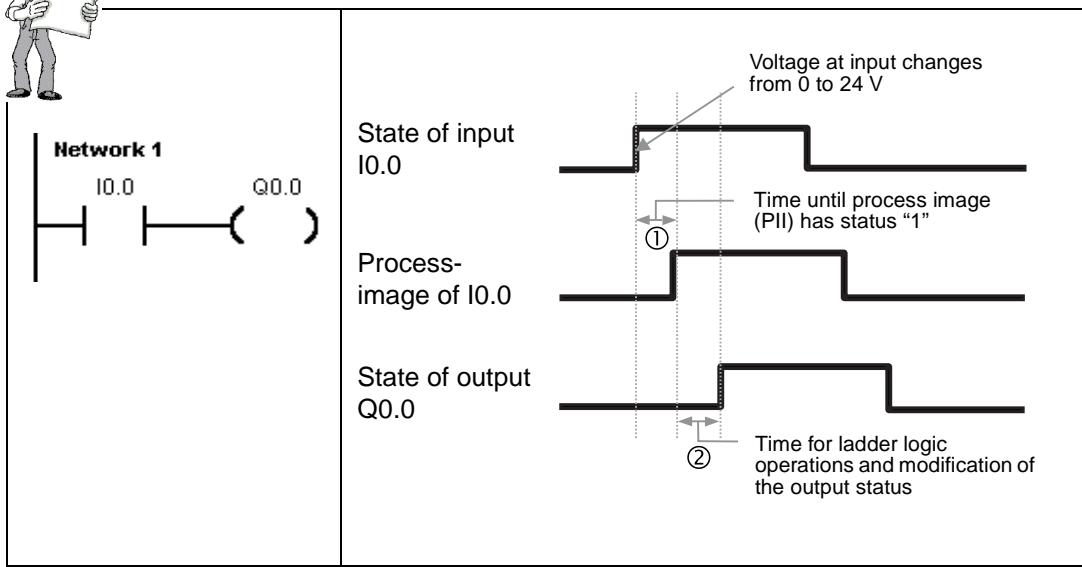

Signal changes at inputs taking place during a cycle are transferred to the input register in the next cycle. There, the signal states for this cycle are "frozen". This is the process-image input table PII (see ①).

In the next cycle, the transferred states are combined in accordance with the ladder diagram (see ②) and the outputs are updated in accordance with the results of the logic operations.

Outputs modified only at the end of the next cycle

Revision

Notes

- Introduction
- Normally-Closed (NC) Contact
- Solution Description and Test
- A Different Take on Latching

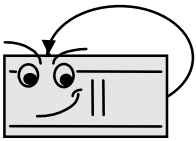

## Introduction

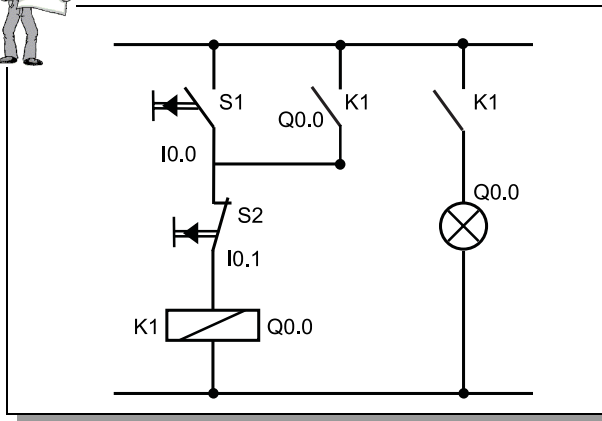

You are sure to be familiar with the standard latching function and here you will learn how to program it. Standard Locking

The example:

Output Q0.30 is to be activated as soon as S1 at input I0.0 is operated. With latching, Q0.0 is to remain active until S2 at input I0.1 is operated and thus interrupts the latch.



In STEP 7-Micro/WIN open the first practice project "a:ld01.prj" from the diskette. There are still a few elements missing in the program. Add the missing LAD elements now as a short exercise.

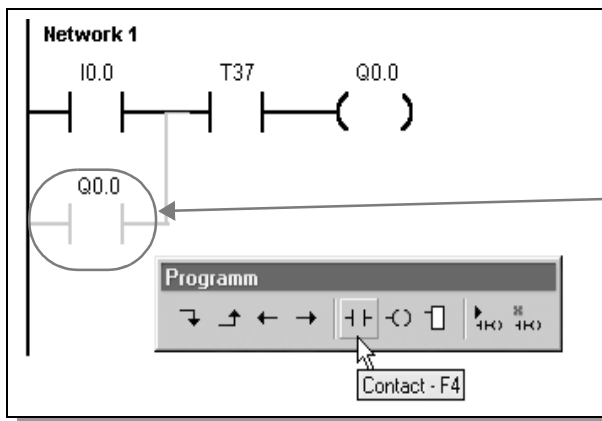

To allow the latching function to work, the output (Q0.0 in this case), must itself ensure, as soon as it is activated, that it retains its "true" state and therefore remains active. Output Q0.0 as an input ensures latching

This is achieved by switching the output (Q0.0 in this case) as a contact in parallel to the tripping input just in the same way as with a conventional contactor circuit (Q0.0 can be compared to our contactor K1).

First add a contact Q0.0 at the point indicated as a parallel circuit to I0.0 (indicated by grey line)! To enter the contact:

1) Click on the ladder diagram field with the left mouse button and click on the STEP 7-Micro/WIN symbol for normally-open NO contact (F4). As indicated on the symbol, you can also use function key F4 instead of the mouse.

2) To enter the vertical line, mark the ladder diagram field of I0.0 and click on the symbol (F7).

- Introduction
- **Normally-Closed (NC) Contact**
- Solution Description and Test
- A Different Take on Latching

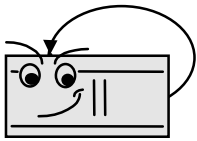

## Normally-Closed (NC) Contact

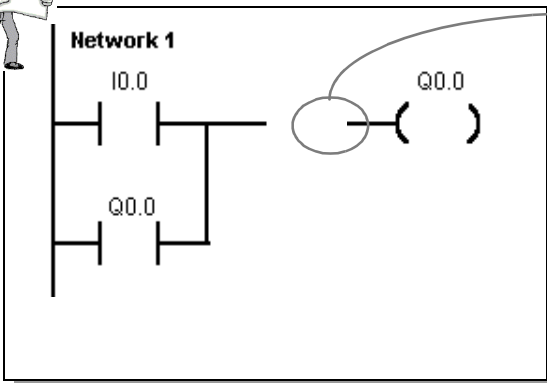

To allow the latching function to be terminated again, input I0.1 is to work like a break in the current path when operated. If a current path is interrupted (i.e. state "0" exists) when a switch is operated, this is referred to as an NC contact.

Consequently, an element must be inserted which works as an NC contact in the ladder diagram when there are 24 V DC ("true") at input I0.1.

NC contact:

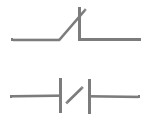

Complete an NC contact for switch S1 at I0.1. This is described on the next page!

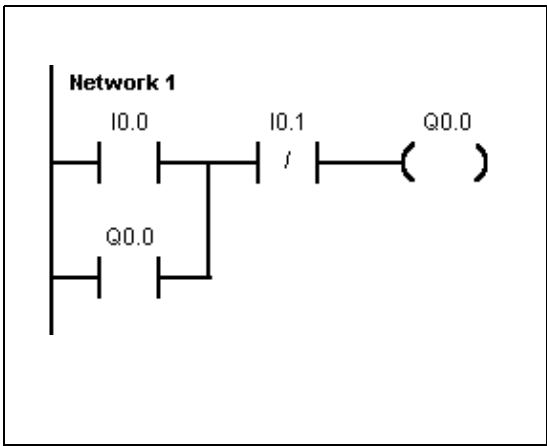

This is what the finished latching function looks like!

Below is the principle of operation shown as a timing chart.

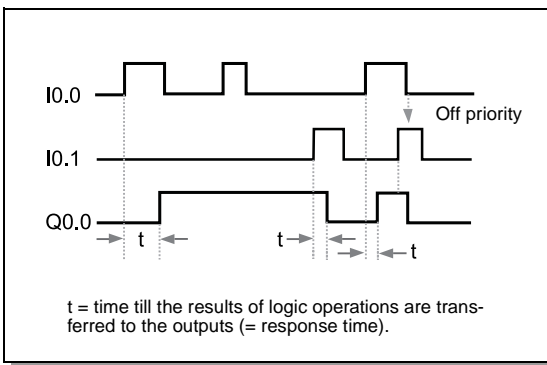

- Introduction
- **Normally-Closed (NC) Contact**
- Solution Description and Test
- A Different Take on Latching

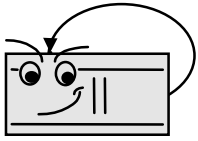

## Normally-Closed (NC) Contact (2)

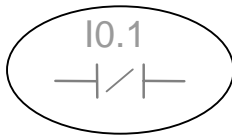

An NC contact interrupts the "current flow" in the ladder diagram when the input or output assigned to it is "true".

Insert the NC contact as follows:

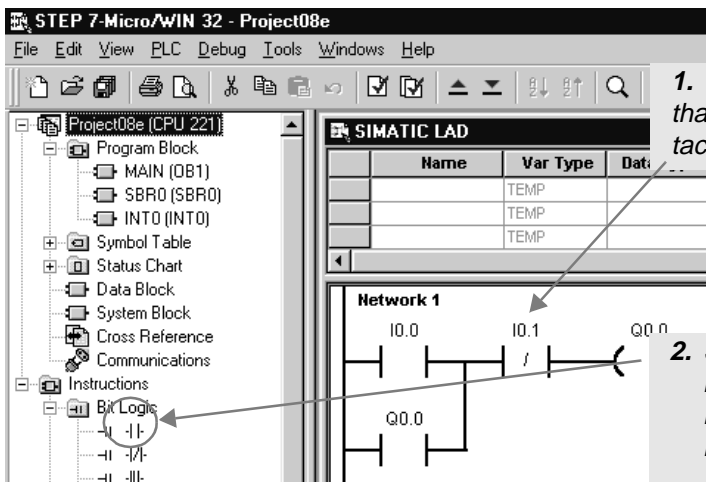

1. Click the mouse to mark the position that is to be replaced with an NC contact.



2. Select the NC contact with the mouse from one of the two available ladder diagram symbol bars in STEP 7-Micro/WIN.

The NC contact is then positioned in the marked field.

3. Finally, the desired element (IO.1 in this case) must be assigned to the NC contact. This is done with an input in the already activated and marked text field.

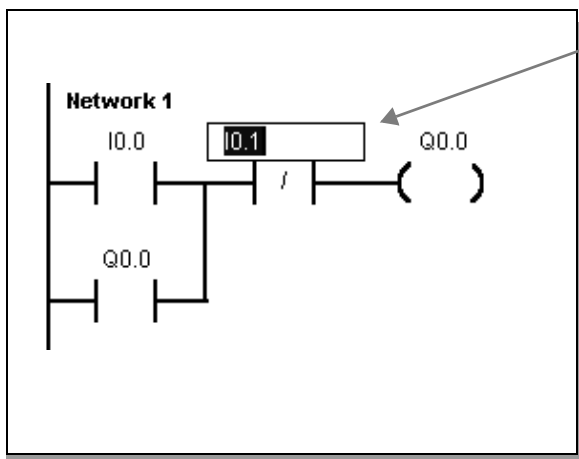

4. Always terminate text field inputs by pressing Enter



- Introduction
- Normally-Closed (NC) Contact
- **Solution Description and Test**
- A Different Take on Latching

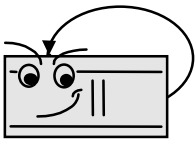

## Solution Description and Test

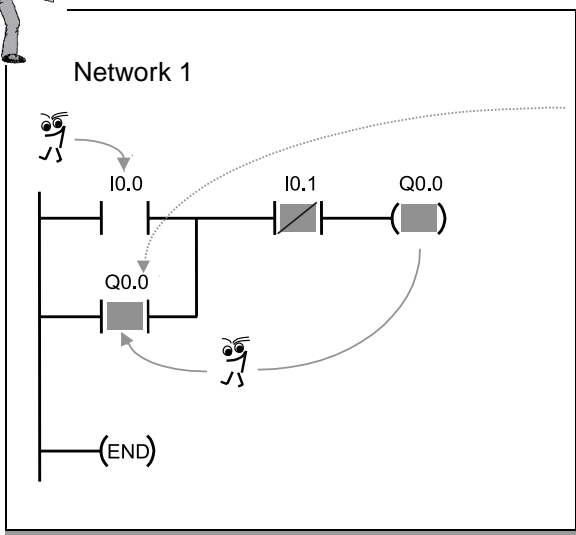

As in the contactor circuit, you have also switched a contact of the output (Q0.0) parallel to the tripping element (I0.0).

Output Q0.0 parallel to the input maintains itself

If, during a cycle, output Q0.0 has been activated by operation of switch S1 at I0.0, contact Q0.0 parallel to I0.0 appears closed in the very next cycle (a few milliseconds later). This brings about latching. NC contact I0.1 can terminate this when switch S2 at I0.1 is operated.



Save your completed program to hard disk. Then you can load it complete again at any time and continue to process it (we will require the program again for our OFF Delay example).



Then transfer the program to the PLC to test the function.



For test purposes, switch the PLC to the "RUN" mode.

Test your program by operating the two switches on the simulator connected at I0.0 and I0.1. Observe the lamps on the S7-200 or the LAD status!  
 Begin by switching on I0.0.  
 I0.1 must be switched off. The LED at I0.0 must light up.  
 Q0.0 will then light up.  
 As soon as I0.1 is switched on, Q0.0 becomes = "0".

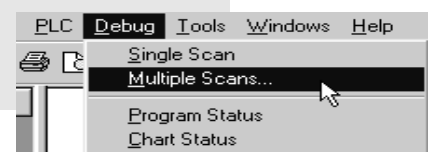

- Introduction
- Normally-Closed Contact
- Solution Description and Test
- A Different Take on Latching

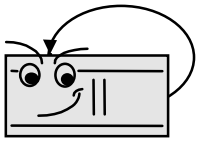

## A Different Take on Latching ... (1)



In PLC technology, latching is often also implemented in another variant:

Instead of feeding back the output - as in the previous example - here the functions "Set" and "Reset" are simply used instead. Have a look first at the ladder diagram below.

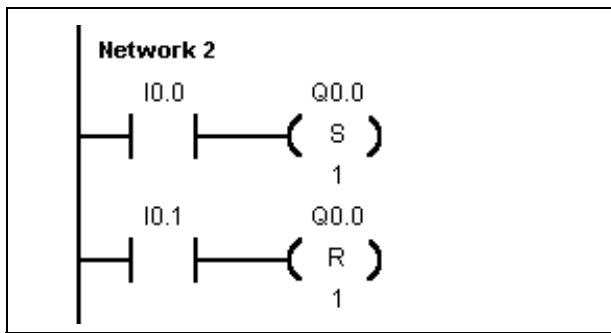

Because of the "Set" operation - **(S)**, a switching pulse at I0.0 has the effect that Q0.0 is activated in a steady state.

-(S)  
Set

In contrast, because of the "Reset" operation - **(R)**, a switching pulse at I0.1 has the effect that Q0.0 is deactivated again.

-(R)  
Reset

The "coils" - **(S)** Set Q0.0 to "1"  
- **(R)** Reset Q0.0 to "0"  
are used frequently in PLC technology to switch briefly activated outputs or bit memories on or off with steady state by means of a series-connected contact.

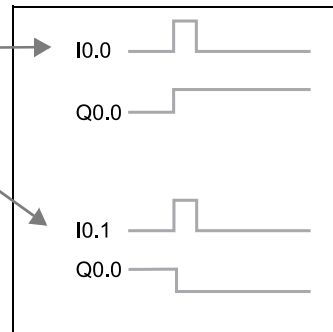

-(S) ⇔ 1

-(R) ⇔ 0

A "set" output or memory bit remains "set" until it is reset by the - **(R)** statement (becomes "untrue").

Steady-state setting of value with (S)  
Resetting with (R)

If the set coil **and** the associated reset coil of an output both have signal "1", the last operation in the program takes **priority**.

Last operation in cycle has priority



- Introduction
- Normally-Closed Contact
- Solution Description and Test
- **A Different Take on Latching**

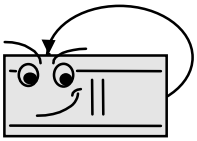

## A Different Take on Latching ... (2)

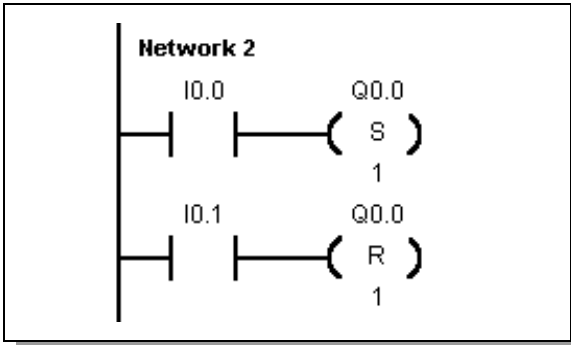

You have already learned how to enter I0.0 and I0.1. Enter the set and reset coil as follows:

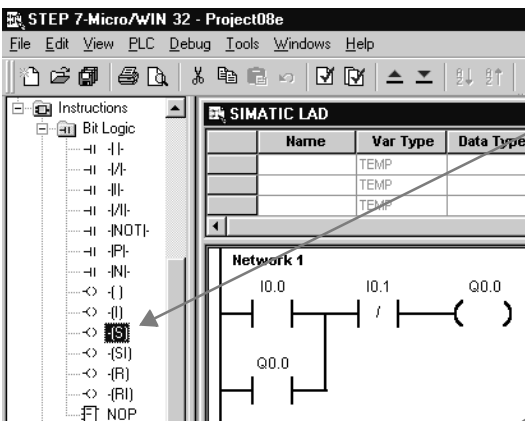

1. After marking the desired LAD field, select "Coils" with a single mouse click from the list for operation families.



Mark

↓-(S)-

2. Then select "Set" (or "Reset") from the list of operations that then opens.

Address

Enter

3. In the already activated text field, enter the output address you want to affect, Q0.0 in this case.

Set (S) or reset (R) up to 255 outputs, timers or bit memories with one instruction

Number (1...255)

Enter ←

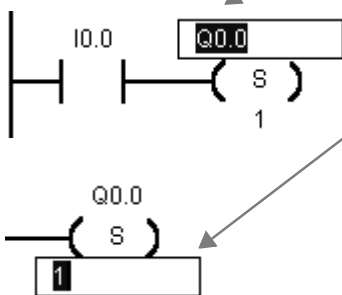

- Introduction
- Normally-Closed Contact
- Solution Description and Test
- A Different Take on Latching

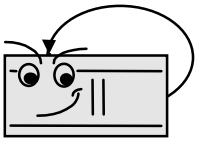

## Safety Aspects

### Shutdown if Wirebreak at Connection to S3

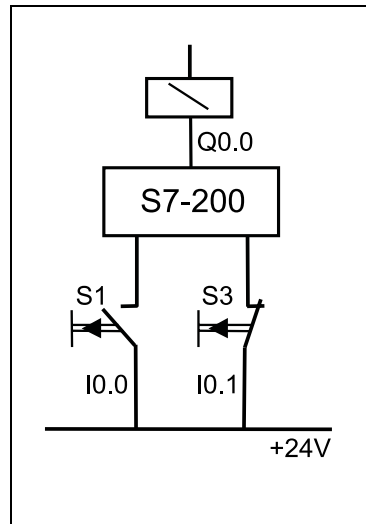
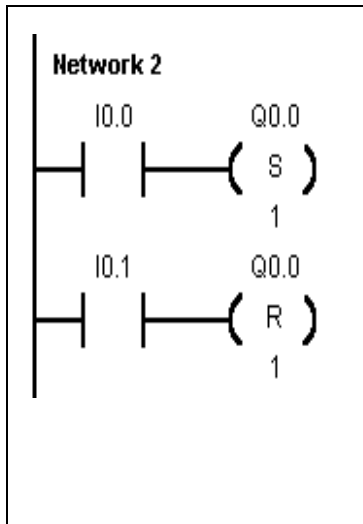

Switch with NC contact that supplies the signal "0" when operated.

In LAD, this signal is reversed by the NC contact I0.1

This means that if you operate the switch S3, Q0.0 is reset.



#### Safety notes

- In the above example, an NC switch S3 was used for resetting. When I0.0 is operated, output Q0.0 is set with steady state. If there are +24 V at I0.1, the "NC contact" supplies the state "0" in LAD. Output Q0.0 is not reset. The LAD "power flow" is interrupted and the coil for resetting is deactivated. If there is no signal (0V) at I0.1 (S3 is open), the NC contact of I0.1 in LAD = "1" and the output is reset.

When an NC switch is used at I0.1, the latching output Q0.0 is reset (switched off again):

- if switch S3 is operated (I0.1 = "0") or
  - if there is a break in the connecting cable between I0.1 and the NC switch. Even in the event of wirebreak, it is guaranteed that a plant component operated in a steady state, e.g. a motor, is switched off.
- The operation "Reset Q0.0" has been entered after the operation 'Set Q0.0' because this means that in the event of both switches being operated simultaneously, clearing the latch takes priority.



In STEP 7-Micro/WIN, open the exercise example "a:ld02.prj" from diskette and test the functions!

Latching

Notes

20

Revision

Latching

Pulse-Oper-  
ated Switch

Off-Delay  
Timer

Sequencer

Appendix

- Introduction
- Solution Overview
- Edge Detection
- Bit Memories
- Solution Description and Test

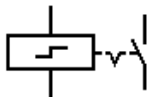

# Introduction



You will implement a pulse-operated switch here. Within this context, you will learn about edge detection and bit memories.

## Principle of operation

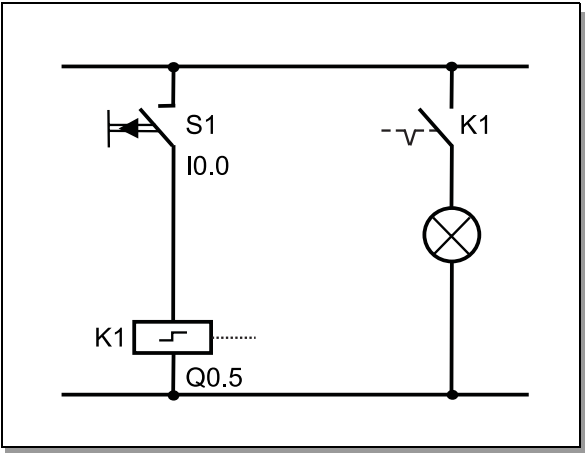

A lamp at output Q0.5 is to be switched on as soon as S1 at input I0.0 is briefly operated.

If S1 (I0.0) is operated again, Q0.5 drop out and the lamp is to go off.

Whenever switch S1 is operated, Q0.5 is to change its state.

This is a "pulse-operated switch".

## Timing chart

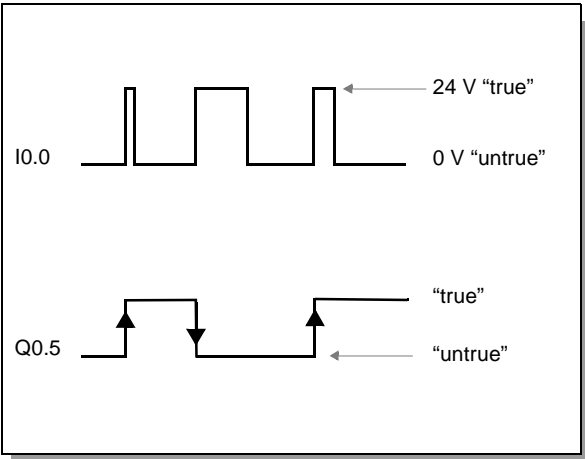

Output Q0.5 is always to reverse its current state once when the switch at I0.0 changes from "open" to "closed".

If the switch remains closed or open, no change takes place.

- Introduction
- **Solution Overview**
- Edge Detection
- Bit Memories
- Solution Description and Test

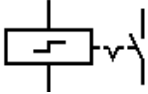

# Solution Overview



Before showing you the step-by-step solution of the task, we will show you the finished solution in order to provide you with an overview.

Detect whether a change of state from "0" to "1" (= positive edge) has taken place at I0.0.

If output Q0.5 is "0", bit memory M0.0 is set, this "flags" that Q0.5 in Network 2 is to become "1".

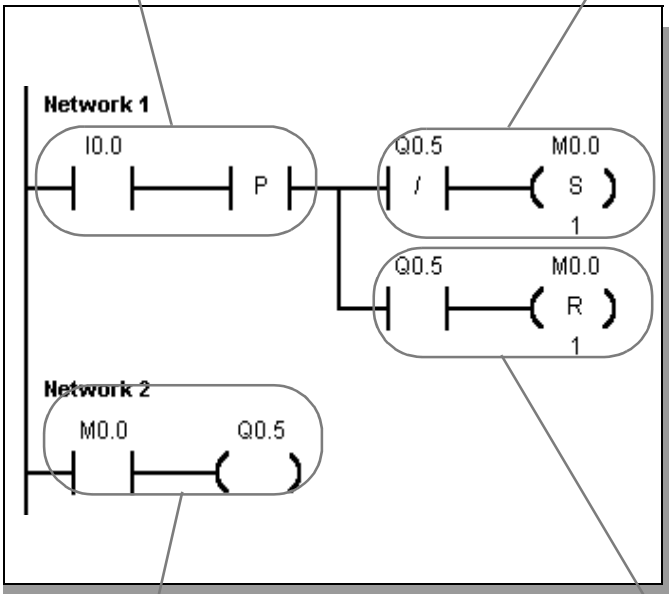

Assign the state of M0.0 to output Q0.5.

If output Q0.5 is "1", bit memory M0.0 is reset, this "flags" that Q0.5 in Network 2 is to become "0".

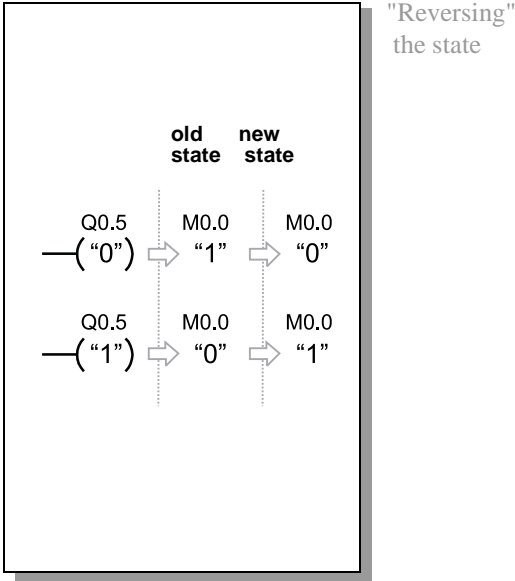

- Introduction
- Solution Overview
- **Edge Detection**
- Bit Memories
- Solution Description and Test

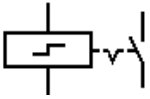

# Edge Detection (1)

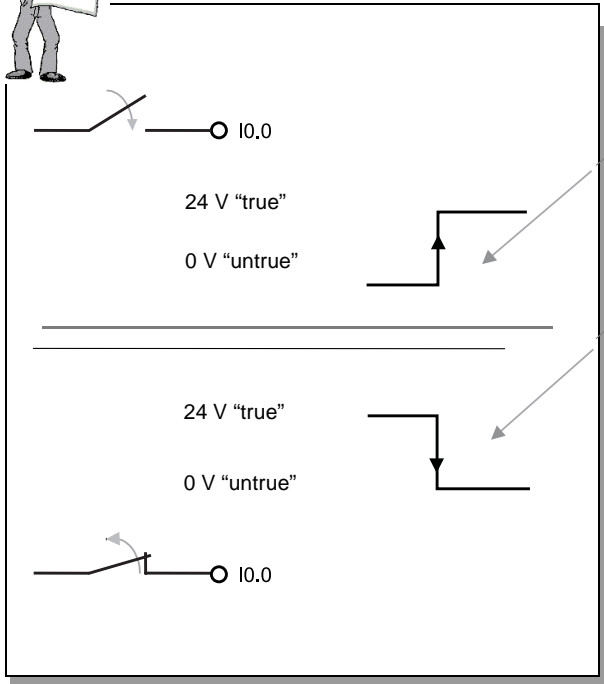

The moment of transition of a contact (input, output ...) from "open" to "closed" or from "untrue" to "true" is referred to as the rising or positive edge.



Correspondingly, the transition from "closed" to "open" or from "true" to "untrue" is referred to as the falling or negative edge.



The two functions  $\text{—|P|—}$  and  $\text{—|N|—}$  are provided for detecting rising and falling edges on the S7-200.

In our example, we use the  $\text{—|P|—}$  function as follows:

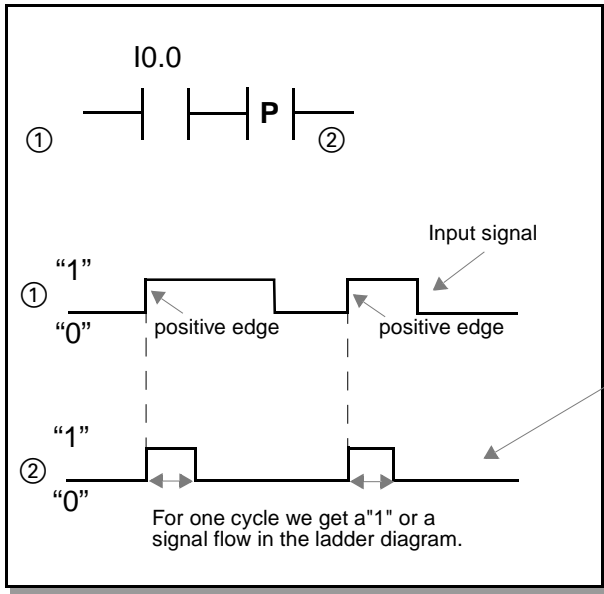

And this is what the signal that generates the  $\text{—|P|—}$  function looks like.



# Pulse-Operated Switch

## Pulse-operated switch

- Introduction
- Solution Overview
- **Edge Detection**
- Bit Memories
- Solution Description and Test

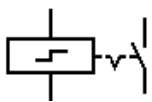

## Edge Detection (2)

The contact  $\text{--}P\text{--}$  for detecting rising edges is closed for the duration of one cycle when the series connected contact changes from "untrue" to "true"

Correspondingly, the contact  $\text{--}N\text{--}$  for detecting falling edges is closed for the duration of one cycle in the event of changes from "true" to "untrue".

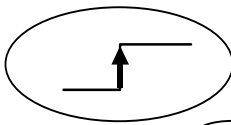
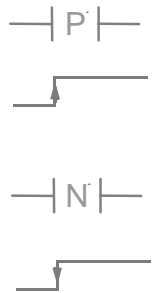

In our "Two-way Switch",  $\text{--}P\text{--}$  is therefore used to pass on a signal to the subsequent logic operations only at the moment that the button at I0.0 is pressed.

And this is how you enter it ...



In STEP 7-Micro/WIN, open the exercise project "a:\d03.mwp" from diskette. This project is also incomplete and will be finished step by step.

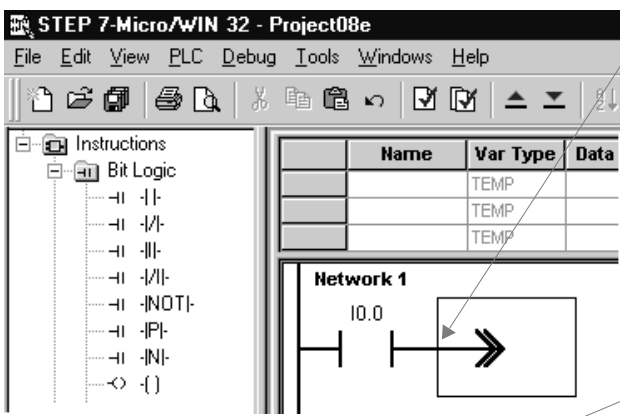

1. Use the mouse to mark the position to be replaced by an edge detection.



2. Select "Contacts" with a single mouse click from the list for operation families.

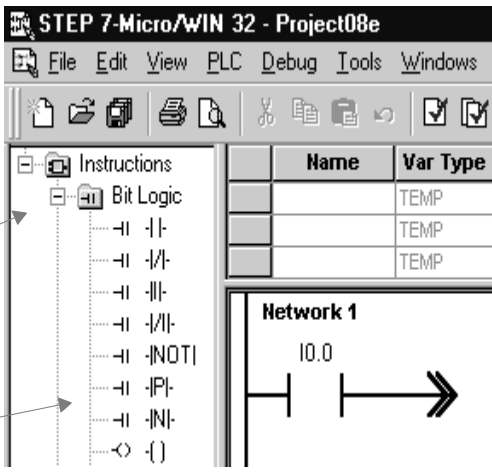

3. Select "Rising edge" or "Falling edge" from the list that then appears.



- Introduction
- Solution Overview
- Edge Detection
- **Bit Memories**
- Solution Description and Test

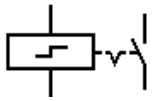

## Bit Memories (1)

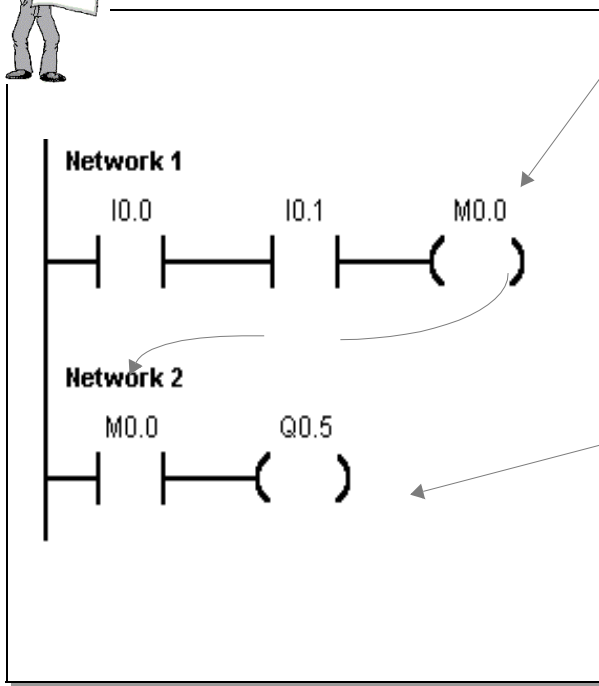

You require bit memories for the pulse-operated switch.

A brief example will serve here to show you how to work with them.

Instead of being used as an output, the bit memory "MO.0" is used as a storage location within the PLC for the interim result of the logic operation "IO.0 AND IO.1".

In this network, the bit memory is used as an "input NO contact" and so controls output Q0.3. The bit memory can still be used at any other location in the program.

Can be used as often as required as NC or NO contact

Bit memories are used for storing interim results, as in the memory of a pocket calculator.

In PLC technology, bit memories are used as outputs and have an effect comparable with auxiliary contactors. A bit memory can be used as often as required at any location as an NC contact or an NO contact.

Used as outputs

Same effect as auxiliary contactors

If the operating power is interrupted, bit memory contents are lost. "Retentivity" is designed to prevent this.

The contents of bit memories is immediately available (in the same cycle) for follow-on logic operations.

Contents immediately updated

Bit memories are used if the (interim) result of a network is to be further processed in other networks (like sub-totals when adding numbers manually). They are also used to store evaluated follow-on states temporarily.

Can be overwritten several times with -(S) or (R)  
Assign only once with -( )-



- Introduction
- Solution Overview
- Edge Detection
- **Bit Memories**
- Solution Description and Test

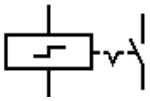

## Bit Memories (2)

Now that you know the function of bit memories, you will be able to understand the solution of the pulse-operated switch.

The  $\text{P}$  function enables signal flow (edge detection) in Network 1 for one cycle each time the button at I0.0 is pressed.

-(S)  
Set

Q0.5 is to change its state at each  $\text{P}$  edge

-(R)  
Reset



We do not write the reversed state (follow-on state) direct to output Q0.5, because the output just set in the "upper" branch, would be immediately reset again in the "lower" branch. For this reason, we write the follow-on state to bit memory M0.0 (= prevents overwriting).

Store follow-on state in bit memory as protection against overwriting

In Network 2, the "set" state of the bit memory is assigned to the output.

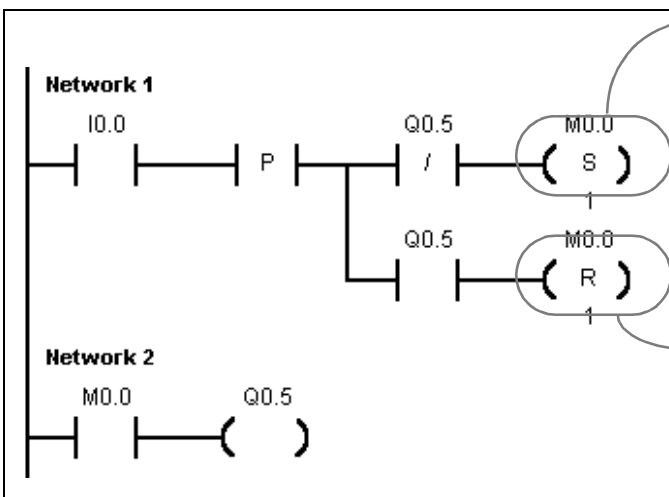

At this point, a coil for setting bit memory M0.0 must be positioned. The number under the coil indicates how many elements are to be set from the specified starting address. Here: Setting of one bit from bit memory M0.0.

M0.0 is set if Q0.5 was not active ("untrue")

Since the lower branch implements the reversed function of the upper branch, the bit of bit memory M0.0 must be reset, or switched off, if this branch "carries current" as the result of the button being pressed.

M0.0 is reset, if Q0.5 was active („true“)

Finally, complete the example in your current exercise project in STEP 7-Micro/WIN as shown above.

- Introduction
- Solution Overview
- Edge Detection
- Bit Memories
- **Solution Description and Test**

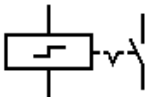

# Solution Description and Test

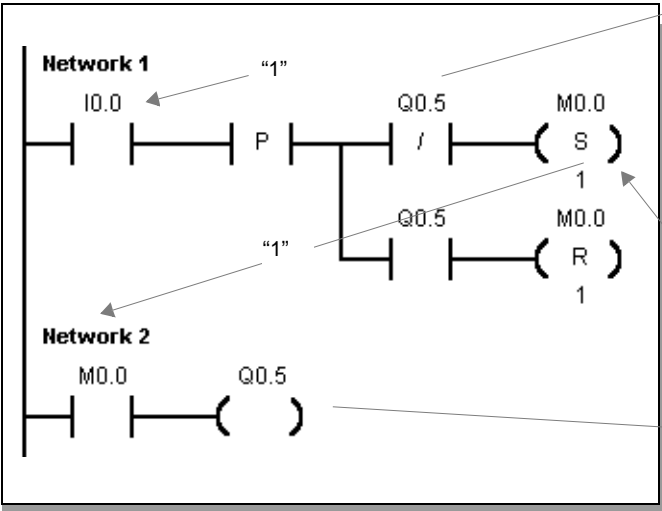

To summarize, the function of our now complete program is explained again below using the example of the upper branch of Network 1 (ends with (S), switch on):

The "current flow" in the ladder diagram is represented at I0.0 in the positive edge cycle!



If I0.0 is operated (-|P|- edge detection)  
**and**  
 Q0.5 is "0" in the current cycle (upper branch is true on scanning with NC contact)  
**then...**  
 flag follow-on state of Q0.5 by setting bit memory M0.0: **-(S)**  
 Setting of one bit from M0.0  
 M0.0 already has the follow-on state of Q0.5 here.  
 Q0.5 is not assigned the new state until the end of the cycle and so does not appear as "true" or "1" in the LAD representation.



-  Save the completed program to hard disk.
  -  Transfer the program to the PLC.
  -  To test, switch the PLC to the "RUN" mode.
- Test your program: Operate the switch at I0.0 and observe output Q0.5.

- Introduction
- Solution Overview
- Edge Detection
- Bit Memories
- Solution Description and Test

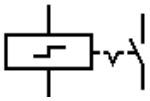

## Time to Show What You Know

... because you've made some real progress!

- ✓ Read and answer the questions below.
- ✓ What is the cycle of a PLC?  
what are the three main components of the "cycle"? See Page 9
- ✓ How is a latching function implemented in PLC technology? See Page 13
- ✓ Normally-closed contact: How is this represented in the ladder diagram,  
what effect does it have, which safety measures can be achieved using it? See Page 14
- ✓ What is an edge, how is it detected and to what purpose? See Page 23
- ✓ What are bit memories, what are they used for? See Page 25
- ✓ How are the "Set" and "Reset" coils entered and what effect do they have? See Page 26



You're sure to know the answers to these questions, even if you have to look up the relevant pages again.

But by now everything will have fallen into place!

# Off-Delay Timer

## Off-delay timer

- Introduction
- Save As ...
- Insert Network
- Solution Description
- Enter Comments

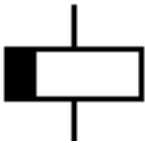

## Introduction



You are already familiar with the On-delay timer from the 1-Hour Primer. We will now implement an Off-delay timer together.

When S1 (I0.0) is operated, a fan motor at output Q0.0 is activated. If S1 (I0.0) is switched off, the fan is to continue to run for 3 seconds and then stop.

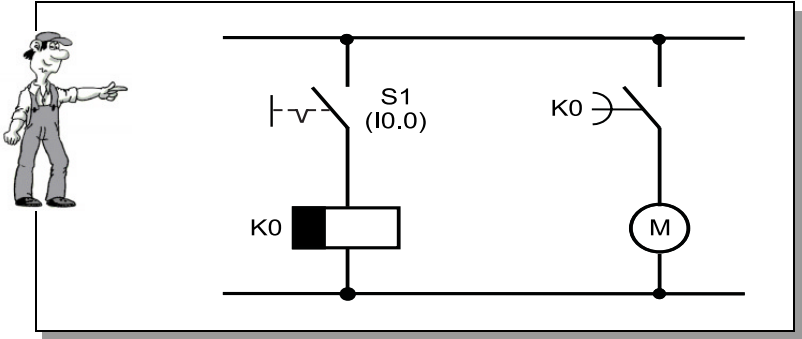

If S1 is switched off, the fan is to continue to run for 3 seconds

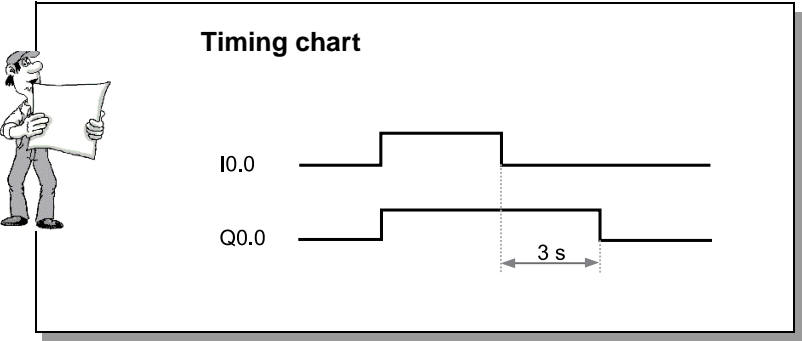

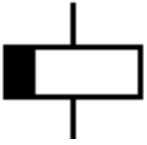

## Introduction



### Procedure

- 1) First, load the complete latching circuit from our first example from the hard disk.
- 2) Then, save the example under a new name on the hard disk.
- 3) Then we create space with "Insert Network"
- 4) We then work together to complete the off-delay timer with comments.
- 5) Finally, we will test the program together.

In the coming pages, we will work through all the steps together to implement the off-delay timer safely.

We wish you every success.



# Off-Delay Timer

## Off-delay timer

- Introduction
- **Save As ...**
- Insert Network
- Solution Description
- Enter Comments

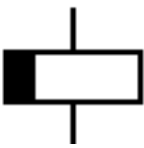

## Save As ...



We will use the latching circuit from the first chapter as the basis for our project.  
Duplicate the entire project by loading it and then immediately saving it under another name.



In STEP 7-Micro/WIN, load your project "d01.prj" (latching circuit) from the hard disk. You stored it there in the first chapter.

Now you want to save the project under a new name. Save the project as described below under the name "d04.prj".

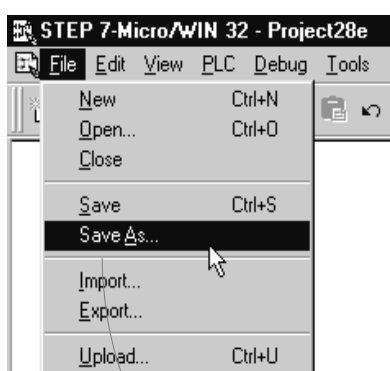

1. Call the menu function "Project > Save As ..."

→ Menu:  
Project,  
Save As...

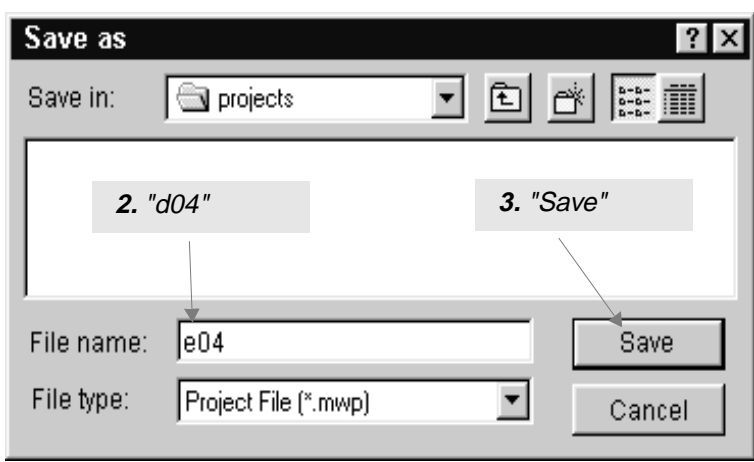

d04.prj  
Save

# Off-Delay Timer

## Off-delay timer

- Introduction
- Save As ...
- **Insert Network**
- Solution Description
- Enter Comments

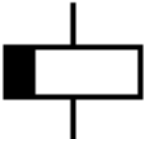

## Insert Network

An additional network is to be inserted in place of Network 2 so that we can implement the off-delay timer. The following steps are required for this purpose:

**1.** Activate the title field of Network 2 by simply clicking the mouse.

**2.** Insert a new network in place of Network 2 (function key F10 has the same function as a click on the button shown).

mark

Network button in the toolbar (F10)



You have created space for the new Network 2 that you will use for implementing the off-delay timer. The contents of the original Network 2 have "moved on" one network.

**Note:**  
There is also the following method of creating space for entering LAD elements:

**3.** Select "Insert ..." from the Edit menu.

Menu: Edit, Insert...

**4.** Select "Network"

Name	Var Type
	TEMP
	TEMP
	TEMP

- Introduction
- Save As ...
- Insert Network
- **Solution Description**
- Enter Comments

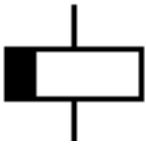

# Solution Overview

I0.0 activates Q0.0  
 Q0.0 maintains its state (latches)  
 since it is also switched simulta-  
 neously in parallel with I0.0.

When T37 has elapsed, the latch function is  
 broken via this contact.  
 The motor stops.  
 If T37 has not elapsed, the latch remains in  
 force.

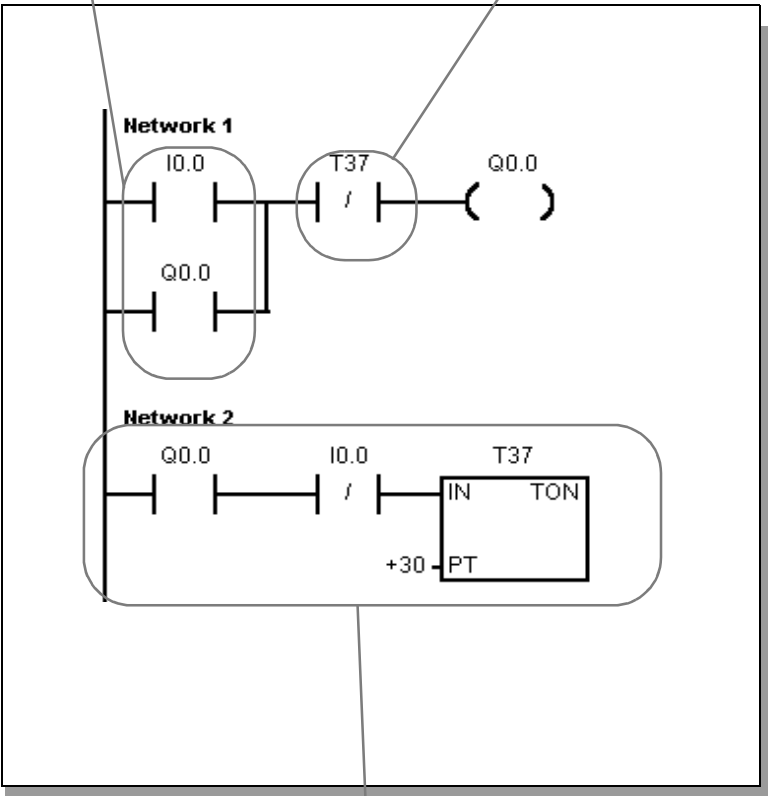

This is how the finished  
 program appears..



When Q0.0 is operated and I0.0 is "0" again  
 (S1 no longer operated), timer T37 starts to run.

- Introduction
- Save As ...
- Insert Network
- **Solution Description**
- Enter Comments

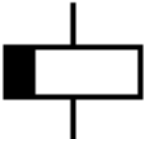

## Solution - Enter Program

Network 1 must look like this:

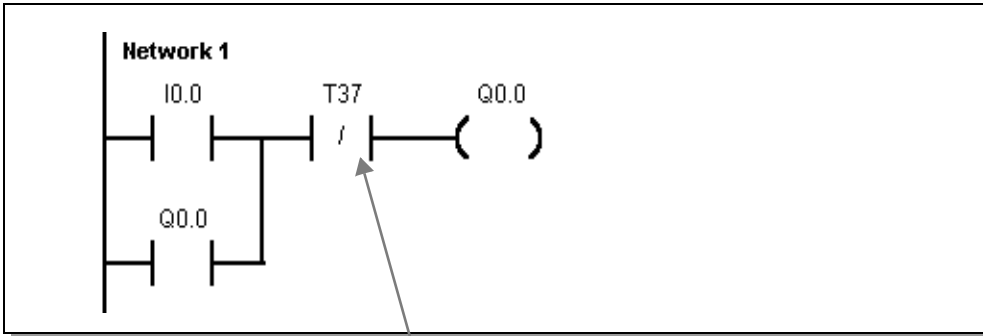

Overwrite I0.1 of the latching circuit with T37.

Enter the following program in Network 2:

Enter T37 with  
F2 Timers/Counters and  
F3 Timer as on delay

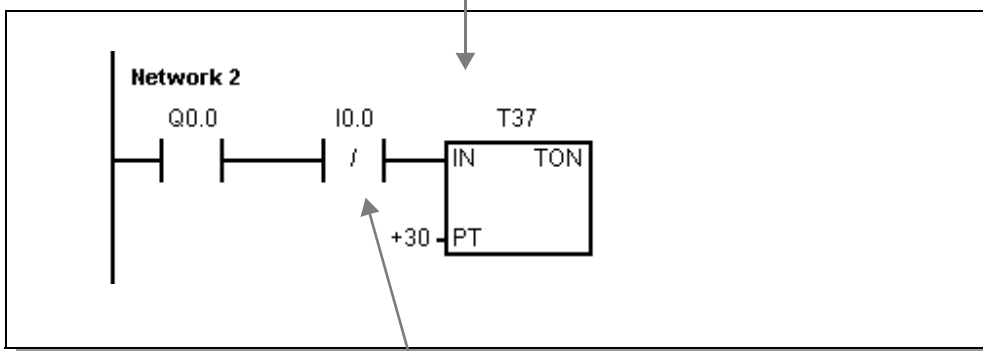

T37 has a timebase of 100 ms (see also  
"1-Hour Primer", Page 36)  
The time value is therefore  $30 * 100 \text{ ms} = 3 \text{ s}$ .

- Introduction
- Save As ...
- Insert Network
- **Solution Description**
- Enter Comments

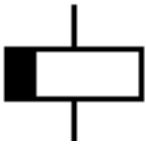

## Solution Description

This is how our program functions. It has two active phases.

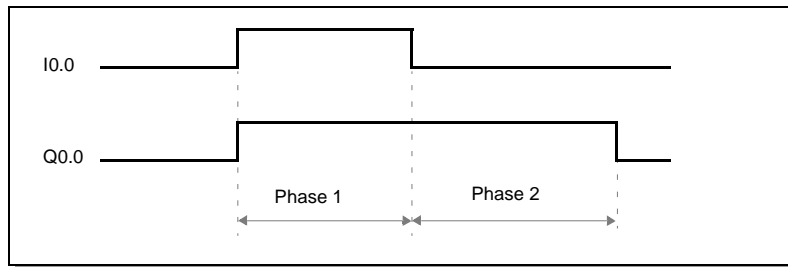

**Phase 1:** Activation of the latching circuit, I0.0 is "1" (we assume that Q0.0 is not active).

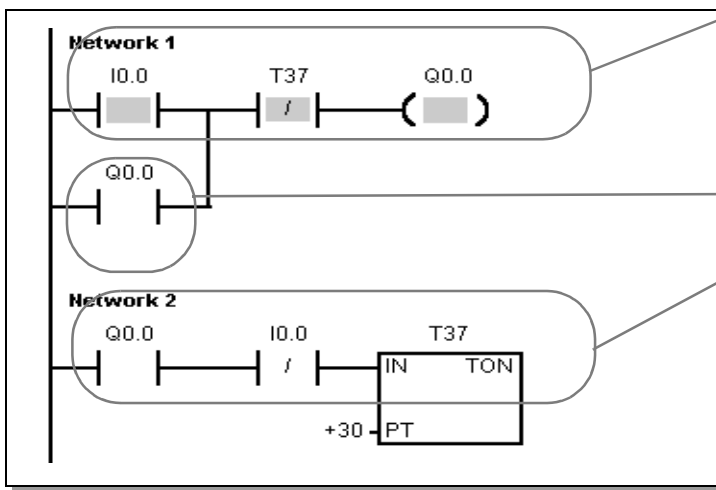

If I0.0 is operated AND T37 has not elapsed THEN Q0.0 is activated (= "1"). Q0.0 latches via this contact.

T37 does not yet run because I0.0 is still "1".

**Phase 2:**

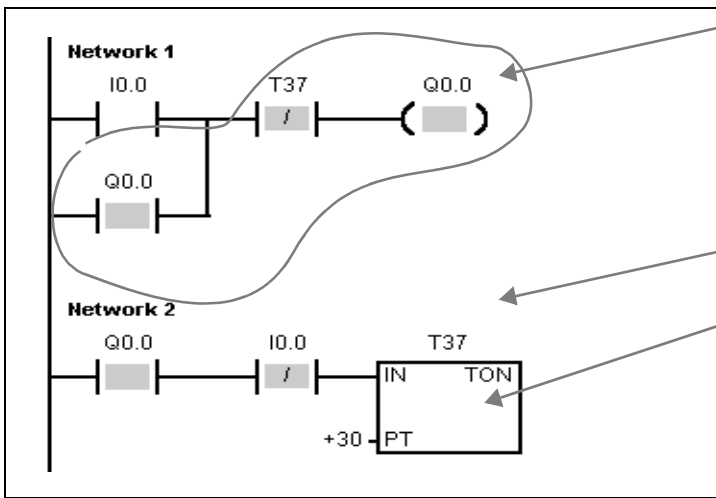

I0.0 is no longer operated.

The latch remains in force until T37 has elapsed. While the timer is running, T37 is "0" and the NC contact lets current pass.

The running of the timer can be monitored here in test mode.

If Q0.0 is active AND I0.0 is no longer operated, timer T37 runs.



## Off-Delay Timer

### Off-delay timer

- Introduction
- Save As ...
- Insert Network
- Solution Description
- Enter Comments

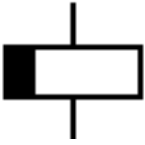

## Enter Comments (1)

Save and try out your new program! If you operate I0.0, Q0.0 is activated.  
If I0.0 is switched off, Q0.0 goes off after 3 seconds.



Well done! Maybe it has already occurred to you that it would be helpful for later work (modifications and such like) to store notes in the program on the principle of operation.

Naturally, we thought of that too. That is why there is a method for entering a title and comments for each network. I'll show you how to do this.

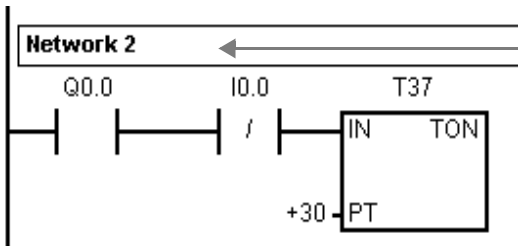

1. Double-click on the title field of Network 2.

2x

2. The Comment Editor is now displayed. Enter the network title here ...

Title

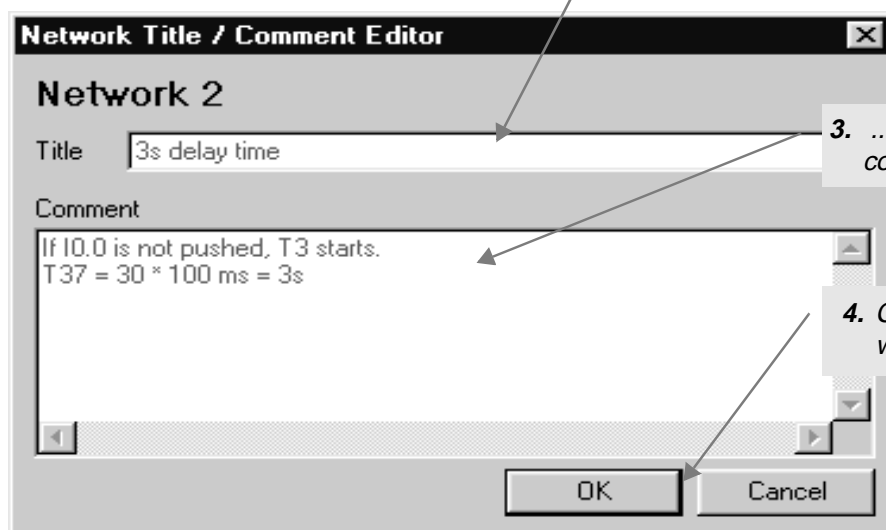

3. ... and the network comments here.

Comments

4. Confirm your inputs with OK.

OK

## Off-Delay Timer

## Off-delay timer

- Introduction
- Save As ...
- Insert Network
- Solution Description
- Enter Comments

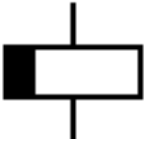

## Enter Comments (2)

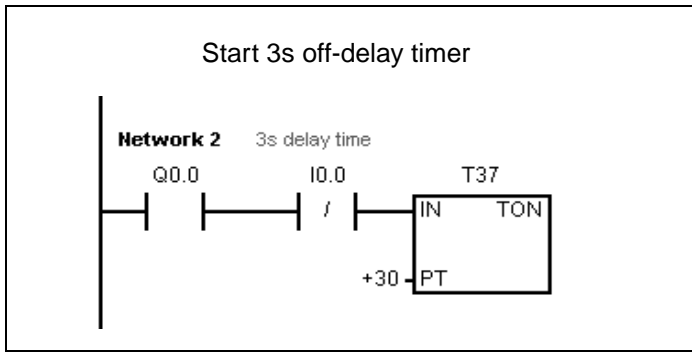

After adding the comments, only the network title is visible on screen.

The comments can be made visible again later by re-activating the Comment Editor.

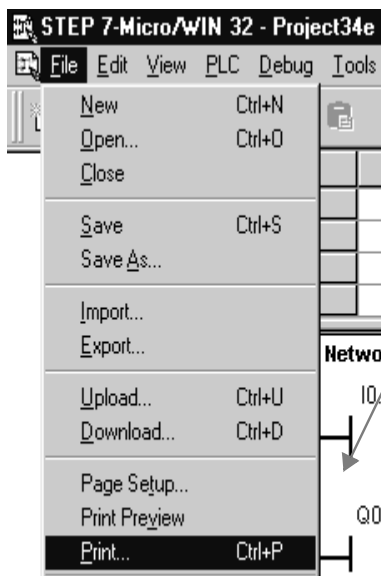

If you want your comments to be included in the printout, you can do so with the menu , function "File/Print/Print Options".

→ Menu:  
Project,  
Page Setup



Print  
Network  
Comments

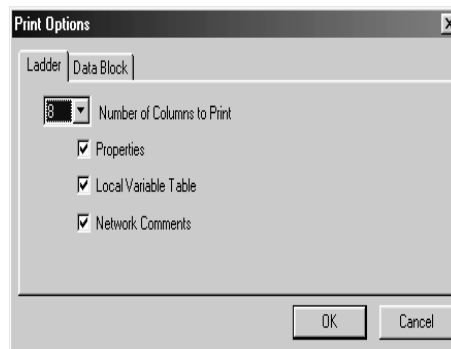
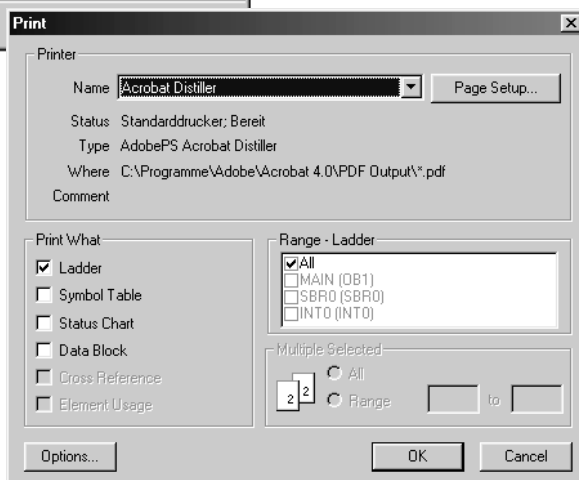

OK

Revision

Latching

Pulse-Oper-  
ated Switch

Off-Delay  
Timer

Sequencer

Appendix

37

- Introduction
- Save As ...
- Insert Network
- Solution Description
- Enter Comments

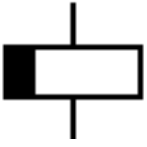

## Time To Show What You Know

Please read and answer the questions below.

- ✓ How do you implement an off-delay timer? Draw the ladder diagram for two possible solutions. Once with the normal coil —( )— and once with **(S)** and **(R)**. See Page 29
- ✓ How do you save a project? See Page 31
- ✓ How do you determine the value of a timer? See Page 36 in  
“1-Hour Primer”
- ✓ What comments can be made on networks? See Page 36

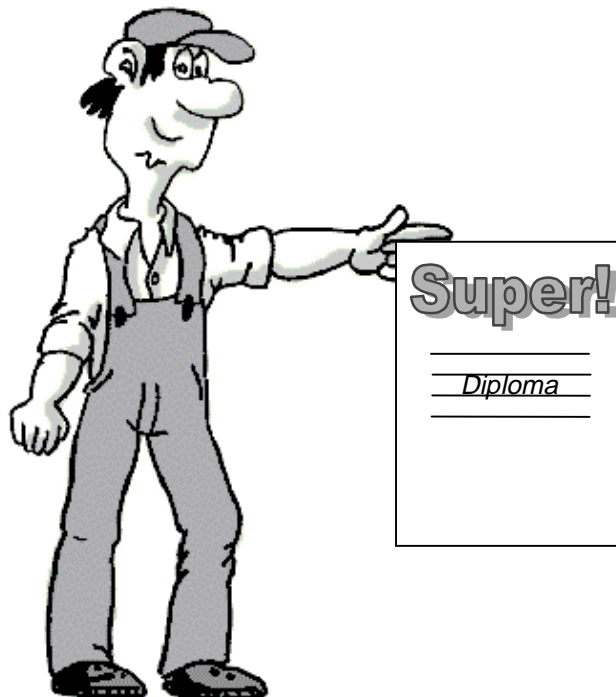

- Introduction
- Basics
- Working with Sequencers
- Modification
- Solution Description, Example
- Test

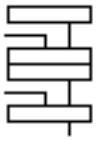

# Introduction

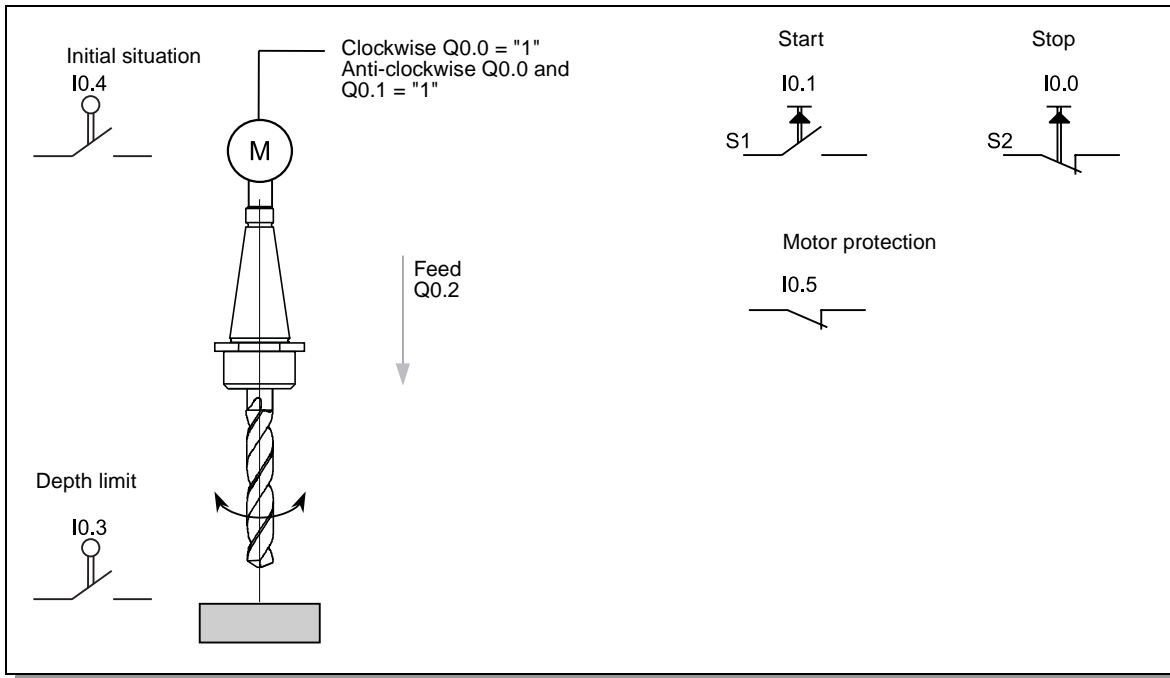

Now we will implement a sequencer together.

*A drill motor is started clockwise with S1. After 3s, the feed is activated.*

*When the depth limit at I0.3 is reached, the feed is de-activated. A spring returns the drill to the initial situation. In doing so, the drive turns anti-clockwise (Q0.0 and Q0.1 are "1").*

*When the initial situation I0.4 = "1" is reached, the drive continues to operate for 1s until the drill is fully switched off. The drill can always be switched off with Stop (activation with I0.0 = "0").*

- Introduction
- Basics
- Working with Sequencers
- Modification
- Solution Description, Example
- Test

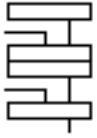

## Solution Starting Point



This is what the solution for the sequencer of the drill example looks like.

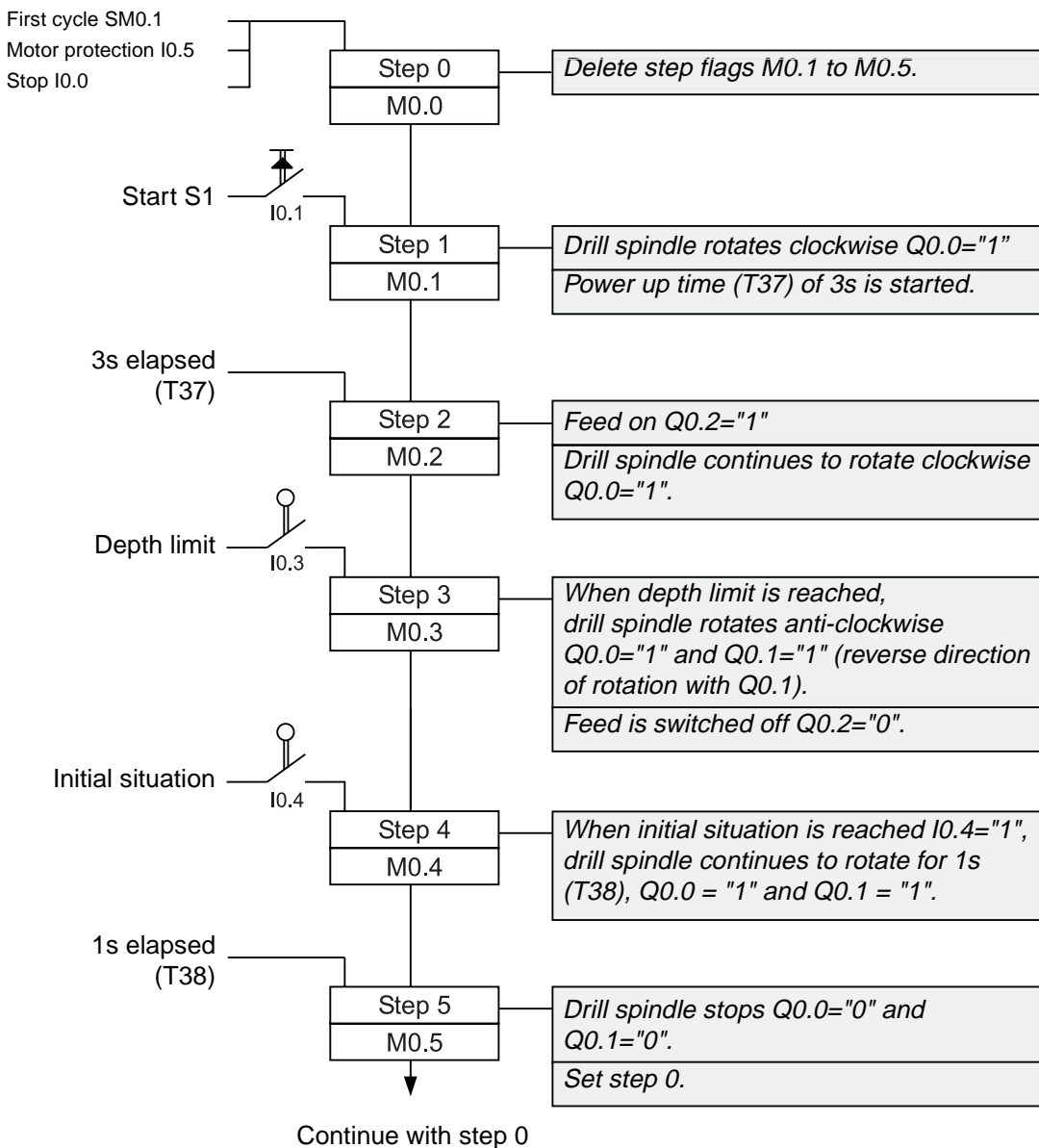

- Introduction
- **Basics**
- Working with Sequencers
- Modification
- Solution Description, Example
- Test

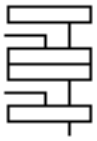

## Basics (1)

We will now solve the drill control with a sequencer.



### What is a sequencer control?

- A control method in which a task is broken down into very small, usually sequential, subtasks (e.g. Motor on, feed on, feed off, ...).
- The subtasks (functions) are called steps.
- Usually one step has to be completed before the next one is started.
- A new step becomes active when the relevant transition condition is active.
- A step is active when the associated step flag, e.g. M0.1 = "1".

Steps

Transition condition

Active step



step flag

MX.Y = "1"

A step is defined for every important state.

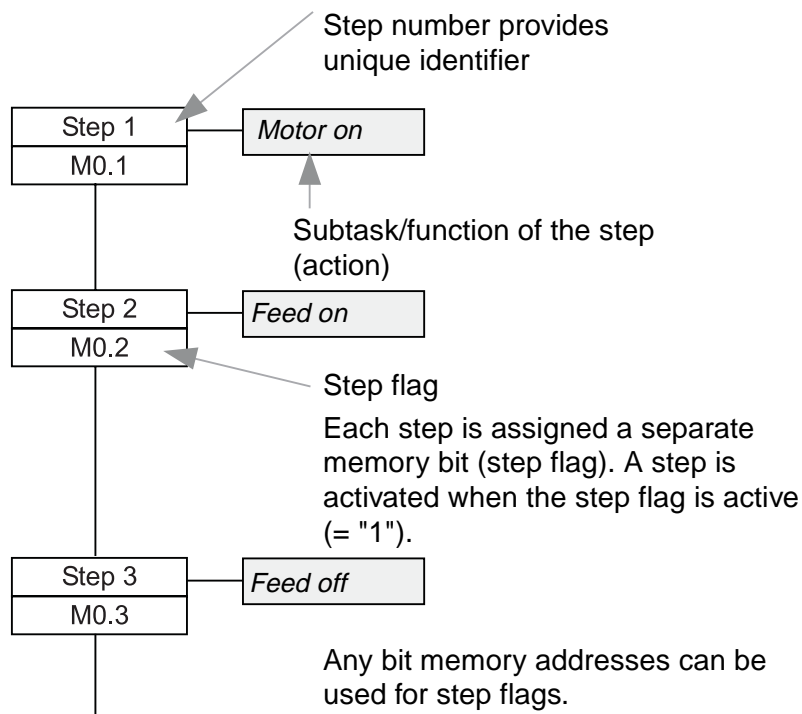
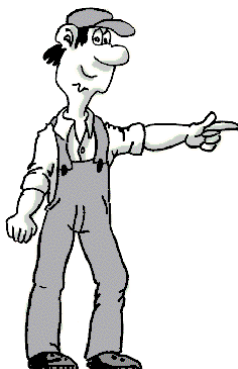

- Introduction
- **Basics**
- Working with Sequencers
- Modification
- Solution Description, Example
- Test

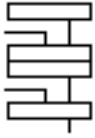

## Basics (2)



### What is a transition condition?

- **Each step is started (activated) by a condition.** The condition is usually derived from the states of the machine. These can include actuated limit switches, operator keys, temperatures reached or timers.
- **An active preceding step is almost always part of the condition.**
- **If a new step flag is set, the step flag of the preceding step is reset.**

Transition condition activates step flag

Active step flag "1"

Always activate only one step at a time.

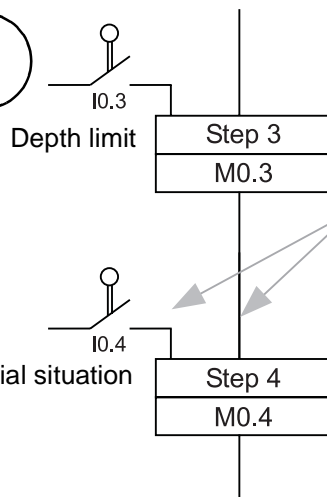

The condition for activating step 4 is:  
I0.4 must be "1" AND M0.3 (the step flag from step 3) must be "1".

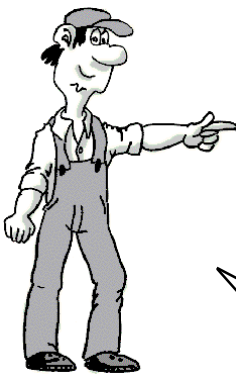

If this condition is fulfilled, e.g. timer elapsed, limit switch actuated, a new step is activated. Usually, another active step is then reset.

When making transitions in the sequencer, we are not yet concerned with the activation of the outputs. This is dealt with in a later program section. This means that a control with sequencers consists of two program sections:

- 1) The actual transitions from step to step when the necessary conditions are fulfilled (transition conditions).
- 2) The activation of the outputs (control valves and drives).

- Introduction
- **Basics**
- Working with Sequencers
- Modification
- Solution Description, Example
- Test

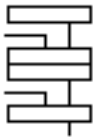

**Basics (3)**

**The two program sections of a sequencer control:**

1) The conditions for activating the individual steps (subtasks) are logically combined with the individual step flags.

Start S1 I0.1, 3s delay, depth limit I0.3, initial situation I0.4, preceding step in each case.

If flags M0.1... become active in sequence, the entire sequencer is processed.

Step flag M0.1, M0.2, M0.3, M0.4

**This defines the overall sequence of the task.**

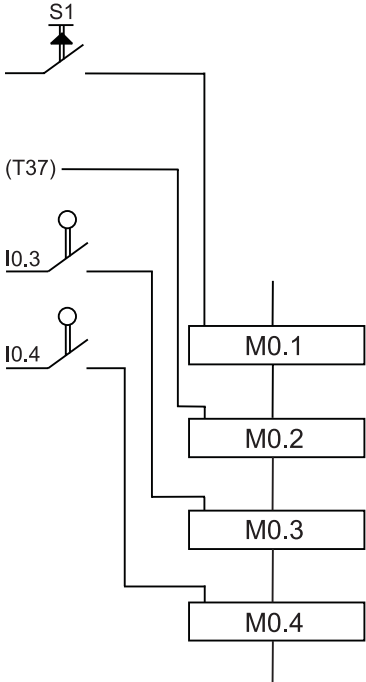

1. Program section  
Start



2) The active memory bits are assigned to the outputs of the PLC which then control contactors or valves, for example.

Q0.1, Q0.2, Q0.0

**This is the interface to the plant /machine.**

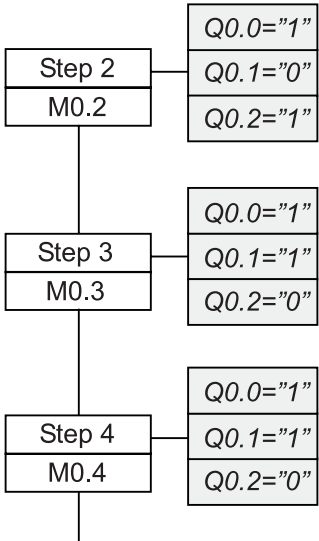

2. Program section

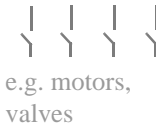

- Introduction
- **Basics**
- Working with Sequencers
- Modification
- Solution Description, Example
- Test

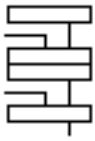

## Basics (4)

### 1) Controlling the sequencer/making transitions in the sequencer

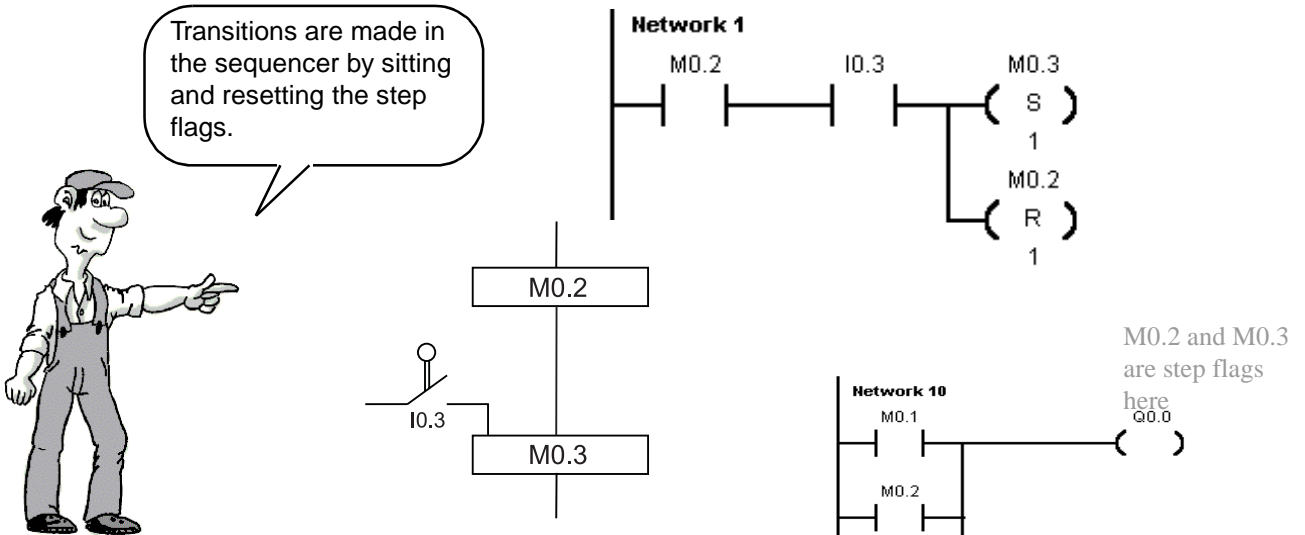

### 2) Setting the outputs via the step flags

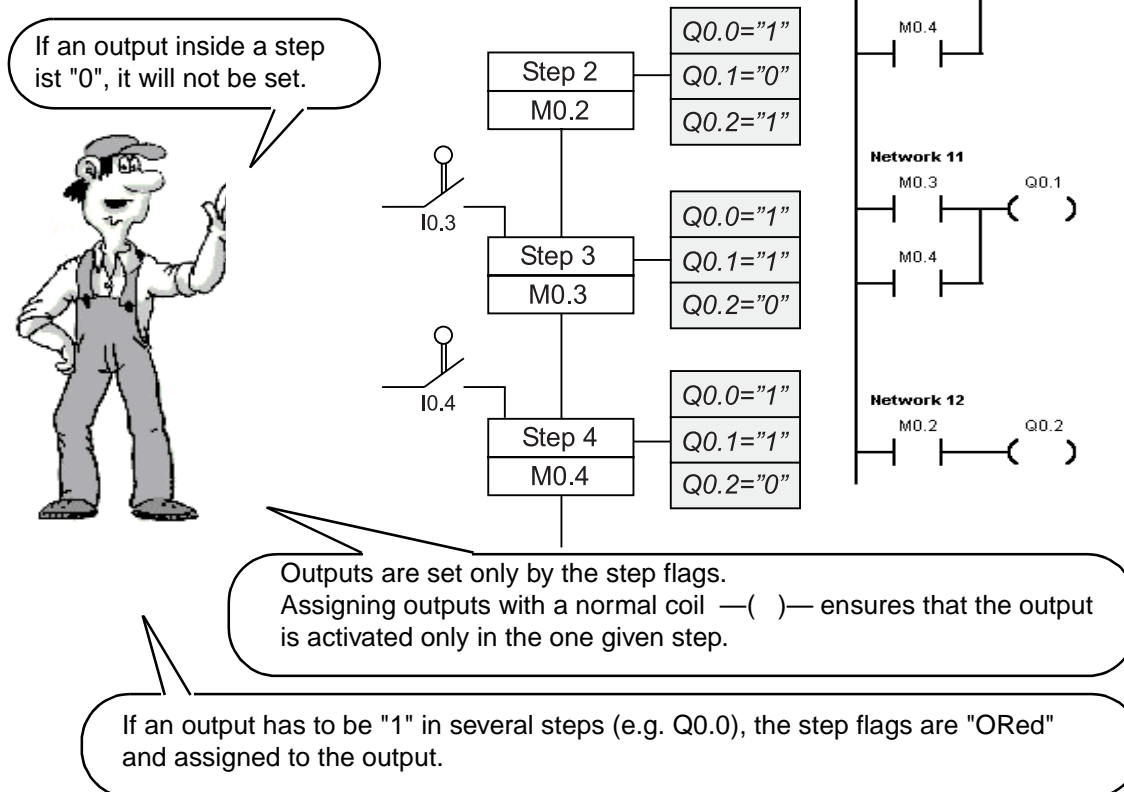

- Introduction
- Basics
- Working with Sequencers
- Modification
- Solution Description, Example
- Test

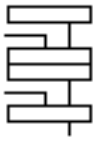

## Working with Sequencers (1)



- A separate memory bit (step flag) is assigned to each step. This is "1" if the step is active.
- For the sake of clarity, only one step in a sequencer should be active at any time. This means only one step flag should be "1".
- If the task is more complex, it is best to use a further sequencer.
- If two or more processes must be controlled simultaneously and independently, separate sequencers are used. This is shown in the diagram below.

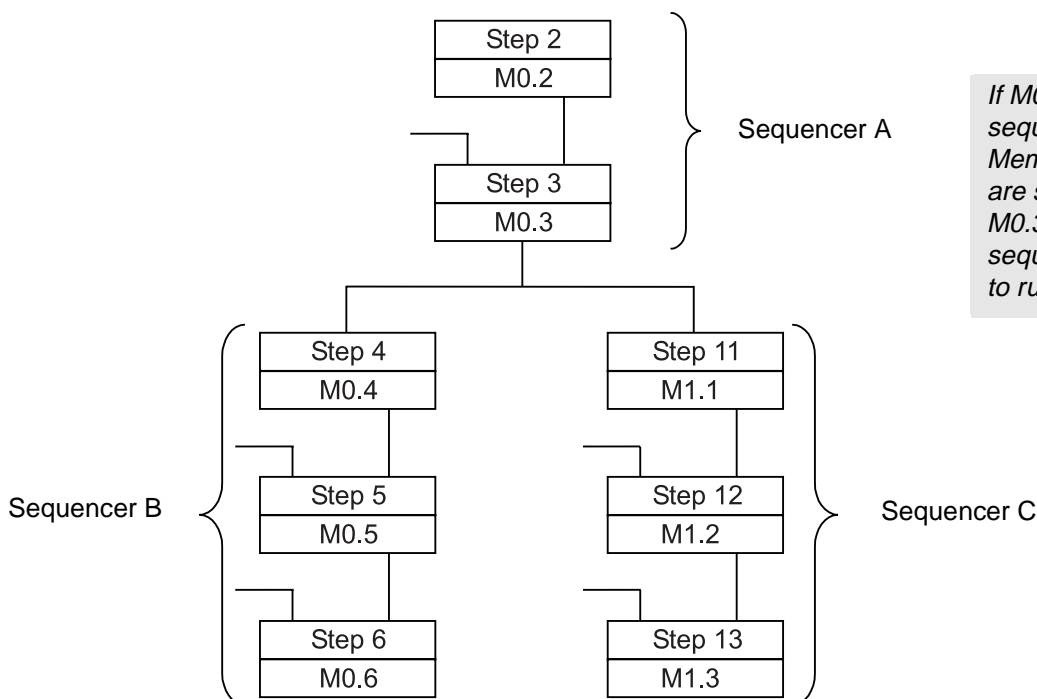

*If M0.3 = "1", the two sequencers B and C start. Memory bits M0.4 and M1.1 are set by M0.3. M0.3 is then reset and sequencers B and C continue to run.*

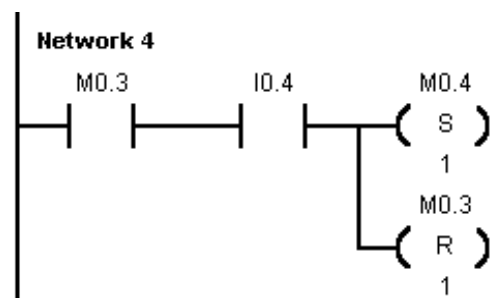

- Introduction
- Basics
- **Working with Sequencers**
- Modification
- Solution Description, Example
- Test

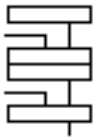

# Working with Sequencers (2)

The transition condition is in practice also made up of several contacts.

Our example can be expanded in such a way that, for example, the start can only take place if the drill is in the initial situation. The sequencer then looks like this at this point:

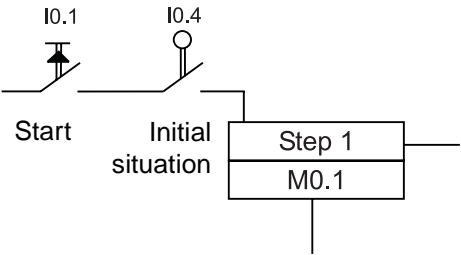

- Introduction
- Basics
- **Working with Sequencers**
- Modification
- Solution Description, Example
- Test

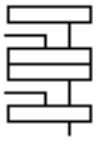

## Working with Sequencers (3)



### Advantages

- **The control section of the sequencer and the setting of the outputs are kept separate**
  - If an output is now to be active in step 7 in addition to step 2 and 3, the program need only be modified at one point.

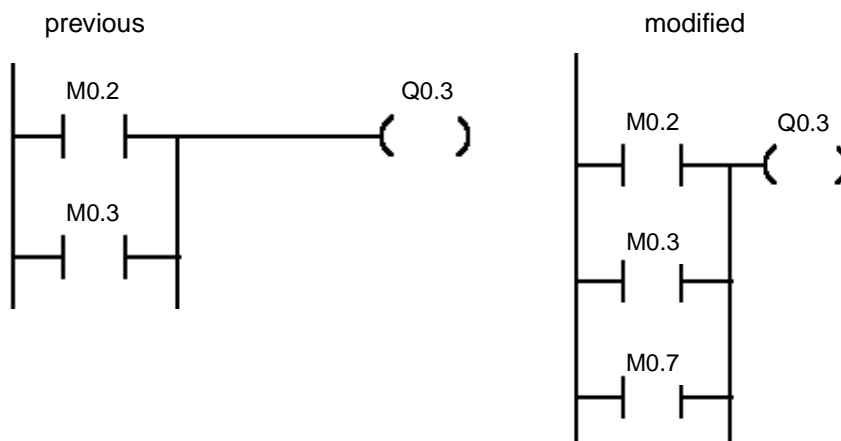

- Modifications to the control section of the sequencer do not affect the setting of the outputs.
- **The program is easy to test**
  - Each step can be traced easily on the programming device.
  - If transitions do not function, it is easy to detect which condition is missing.
- **Machine**
  - If a machine ceases to operate, it is easy to detect the missing transition condition from the mechanical position of the machine and the active step flag.
- **Fewer programming errors, faster startup**
  - Using sequencers forces you to structure your programs which in turn minimizes programming errors.

- Introduction
- Basics
- **Working with Sequencers**
- Modification
- Solution Description, Example
- Test

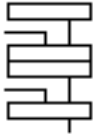

## Important Safety Points (1)



There should be not drives or valves active in the first step flag (initial situation). In our example, this is step 0 or step flag M0.0.

*When "STOP" is operated or a motor protector picks up, the first step flag (M0.0 in our example) need only be set for all drives to come to a stop. At the same time, all other step flags must be reset.*

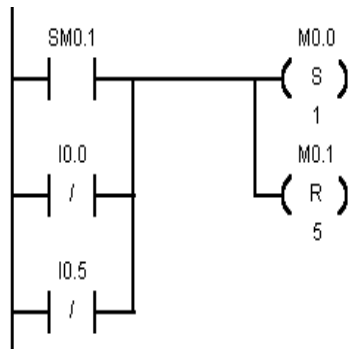

*M0.0 is set, M0.1 to M0.5 are reset*

- in the first cycle after power restore by SM0.1 or
- if IO.0="0" or
- if IO.5="0".

SM0.1 supplies "1" for one cycle in the first cycle after restarting

The program section shown in the example must be at the end of the "normal" transition conditions of the sequencer. This ensures that any necessary shutdown can take place prior to activating the outputs.

- Introduction
- Basics
- **Working with Sequencers**
- Modification
- Solution Description, Example
- Test

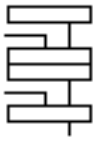

## Important Safety Points (2)

Program section 1 – Making transitions in the sequencer:

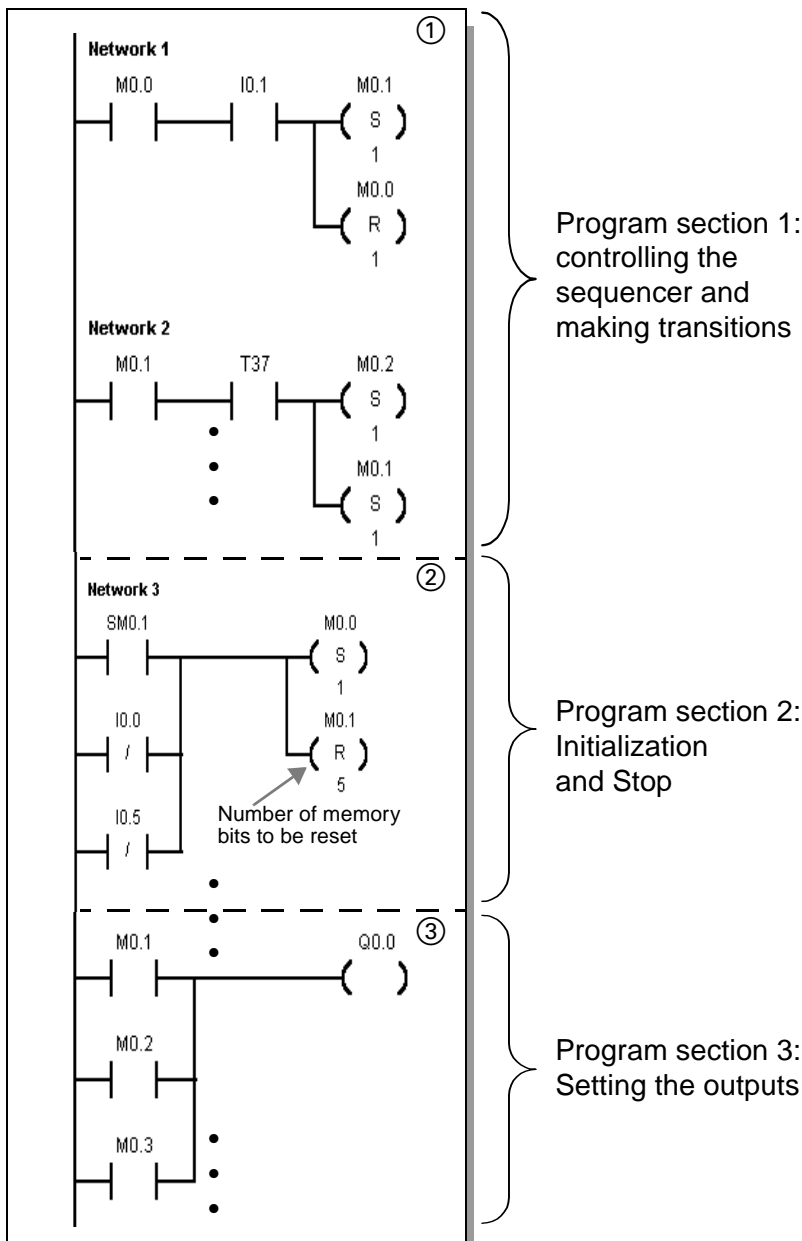

Before assigning the first output ③, the program section for activating the initial situation must be in place ②. This ensures that activation of the initial situation has the highest priority.

- Introduction
- Basics
- Working with Sequencers
- **Modification**
- Solution Description, Example
- Test

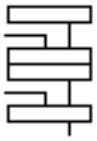

## Modification



Network 6 determines in which step the program jumps to step 5. In the example, it jumps in step 0.

This is controlled by:

*Setting M0.0 and resetting M0.1 to M0.5.*

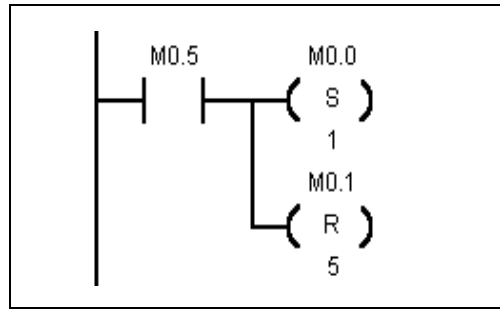

If the program is to jump automatically to step 1 following step 5, Network 6 must look like this.

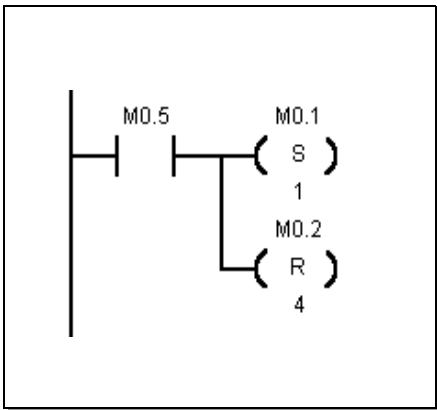

This modification causes the drill to run automatically until stopped by I0.0 or I0.5.

- Introduction
- Basics
- Working with Sequencers
- Modification
- **Solution Description, Example**
- Test

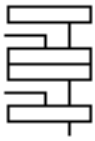

## Solution Description, Example (1)

### Program section 1 - Making transitions in the sequencer

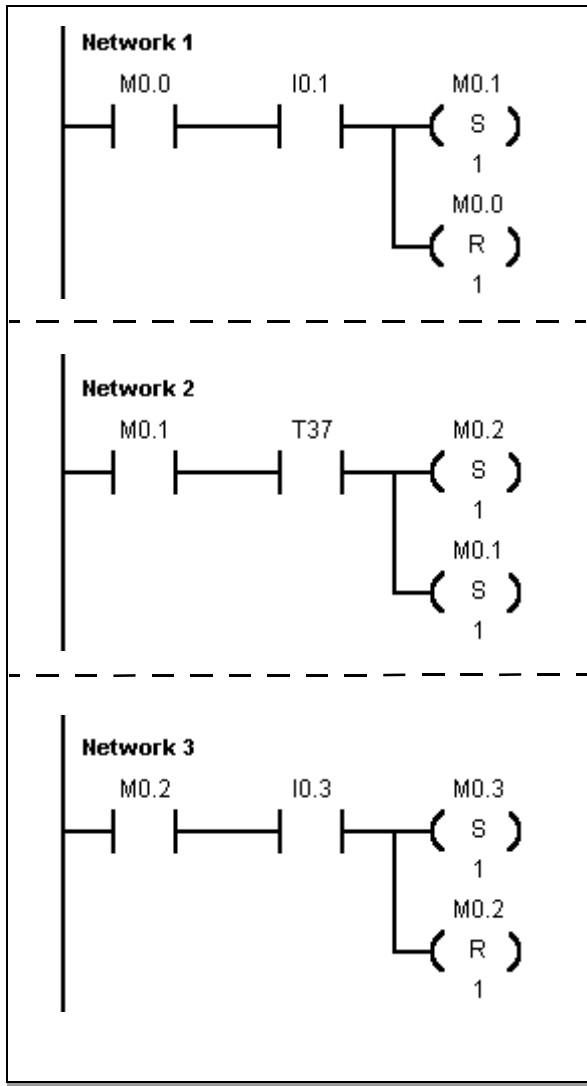

#### Activating step 1

Step flag M0.1 is set when the sequencer is in the initial situation (M0.0 = "1") AND I0.1 is operated. At the same time, M0.0, the step flag of the initial situation, is reset.

#### Activating step 2

Step flag M0.2 is set if the sequencer is at step 1 (M0.1 = "1") AND timer T37 has elapsed. At the same time, step flag M0.1 is reset.

#### Activating step 3

Step flag M0.3 is set if the sequencer is at step 2 (M0.2 = "1") AND input I0.3 depth limit becomes "1". At the same time, M0.2 is reset.

- Introduction
- Basics
- Working with Sequencers
- Modification
- **Solution Description, Example**
- Test

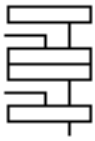

## Solution Description, Example (2)

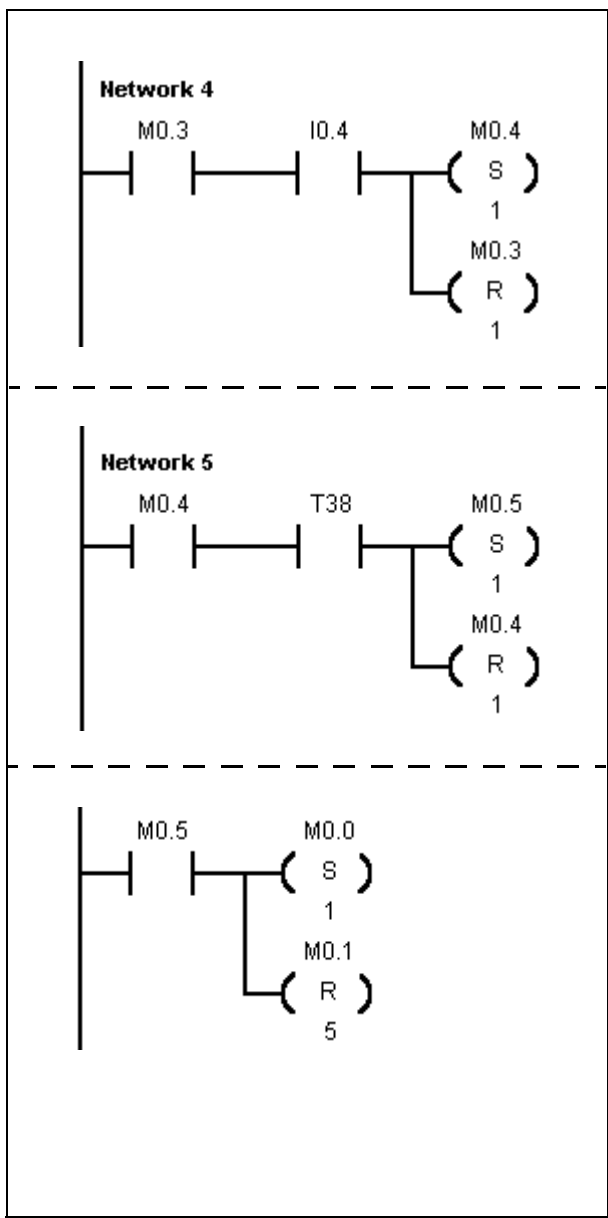

### Activating step 4

Step flag M0.4 is set if the sequencer is at step 3 (M0.3 = "1") AND input I0.4 (initial situation) becomes "1". At the same time, M0.3 is reset.

### Activating step 5

Step flag M0.5 is set if the sequencer is at step 4 (M0.4 = "1") AND timer T38 has elapsed. At the same time, step flag M0.4 is reset.

### Activating step 0

If step flag M0.5 is active (overshoot time T38 is finished), step 0 (initialization step) is activated from the sequencer. This step in Network 6 has been included deliberately so that further conditions such as removal of the workpiece could be scanned at this point before re-activation of step 0.

This condition would then have to be switched in parallel to contact M0.5.

- Introduction
- Basics
- Working with Sequencers
- Modification
- **Solution Description, Example**
- Test

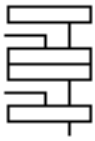

## Solution Description, Example (3)

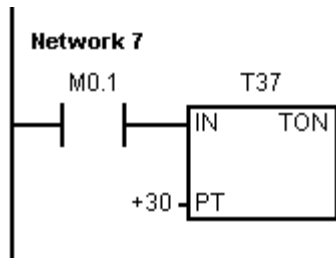

### Activating timer T37

If step 1 is active (M0.1 = "1"), timer T37 is started.

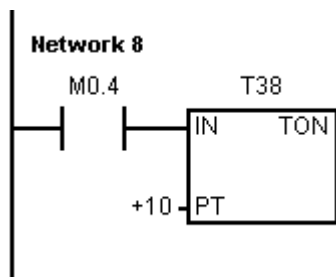

### Activating timer T38

If step 4 is active (M0.4 = "1"), timer T38 is started.

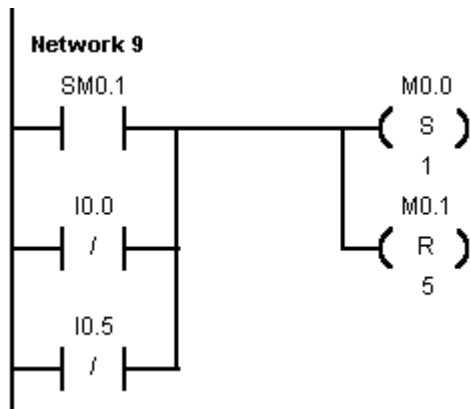

### Initialization of a sequencer

Step flag M0.0 is set

- 1) in the first cycle (SM0.1 is "1" here for one cycle)  
OR
- 2) if Stop is operated (I0.0 = "0")  
OR
- 3) if the motor protection has picked up (I0.5 = "0").  
At the same time, step flags M0.1 to M0.5 are reset.

- Introduction
- Basics
- Working with Sequencers
- Modification
- **Solution Description, Example**
- Test

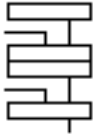

## Solution Description, Example (4)

### Program section 2 - Setting the outputs

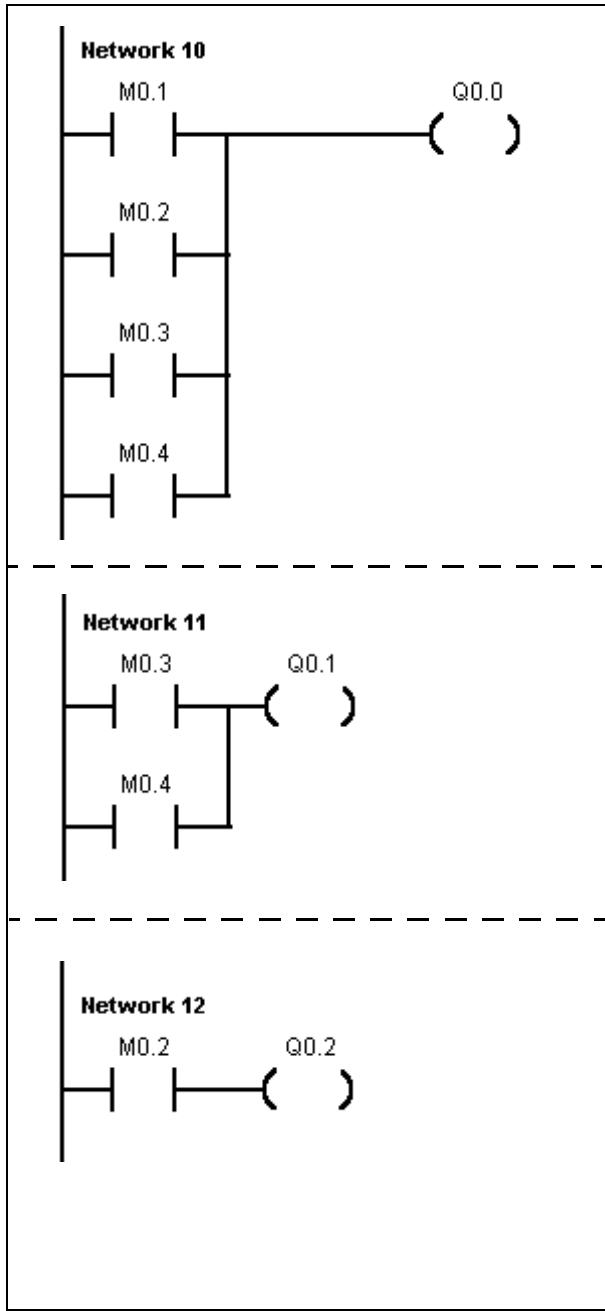

#### Activate output Q0.0 (drive clockwise)

Output Q0.0 is "1" in steps 1, 2, 3, 4, i.e. if M0.1 or M0.2 or M0.3 or M0.4 are "1".

#### Activate output Q0.1 (direction reversal)

Output Q0.1 is "1" in steps 3 and 4, i.e. if M0.3 or M0.4 are "1".

#### Activate output Q0.2 (feed on)

If memory bit M0.2 = "1" output Q0.2 will become "1".

- Introduction
- Basics
- Working with Sequencers
- Modification
- Solution Description, Example
- Test

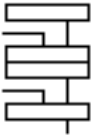

## Test

You can enter the program yourself or load the file "**d05.prj**" from the diskette. Please note that the stop switch I0.0 and the motor protection I0.5 are "normally-closed (NC) contacts". This has been implemented in this way for safety reasons. A wirebreak between the switches and the PLC stops the machine!

I0.5 and I0.0 must be "1" for test purposes, that is, the input LEDs must light up.

Briefly operating I0.1 starts the drive. The feed Q0.2 switches on after 3 s. After I0.3 is operated, the drive reverses its direction of rotation and the feed Q0.2 stops.

If the initial situation is reached (brief operation of I0.4), the drive stops after 1s.

I0.0 and I0.5 stop the drive in every phase.

Observe the program in test mode. You will see exactly which input is required in each case for making the transitions in the sequencer.

Try it out !

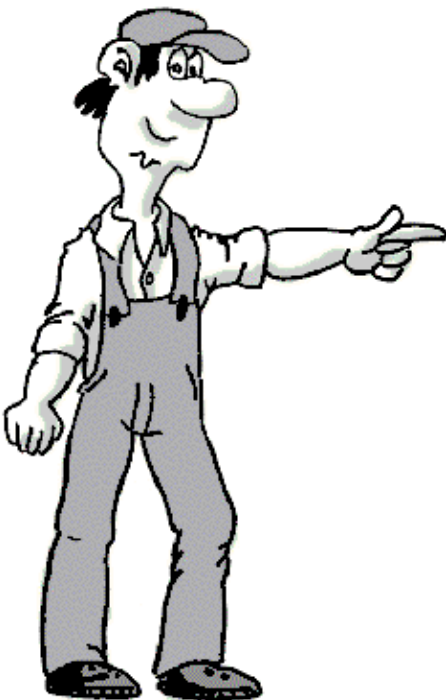





Made it.

Now you can solve tasks yourself using the S7-200. If you want to implement complex contactor circuits, you can find some useful tips in the Appendix.

Revision

Latching

Pulse-Operated Switch

Off-Delay Timer

Sequencer

Appendix

57

Revision



Latching



Pulse-Oper-  
ated Switch



Off-Delay  
Timer



Sequencer



Appendix

## Fancy Some More?

You can find more examples in the "**Samples**" folder in your STEP 7-Micro/WIN folder or the "Tips & Tricks" for the S7-200. You can obtain the "Tips & Tricks" from your SIMATIC contact.

The S7-200 manuals contain further information. You can get comprehensive further training in an S7-200 course at your Siemens Training Center or from your SIMATIC contact.

Unanswered questions  
or technical problems:  
The SIMATIC contacts  
are glad to help.



Please get in touch with your SIMATIC contact who supplied your Startup Package. He/she will be glad to help.

If your contact is unavailable, please call our SIMATIC Hotline, Tel.: ++49 911/895-7000.

Revision



Latching



Pulse-Oper-  
ated Switch



Off-Delay  
Timer



Sequencer



Appendix

We have put together a few examples below to make it easy for you to implement even complex "switching operations" in ladder logic.



Revision



Latching



Pulse-Oper-  
ated Switch



Off-Delay  
Timer



Sequencer



Appendix



## Bridge Circuit

If you are changing over from contactor technology to PLC technology will very probably encounter switch combinations that cannot be converted directly into ladder diagram representation. Included among these is the bridge circuit. Brief solutions are sketched here both for the simple and the more complex bridge circuit.

### 1) Simple bridge circuit

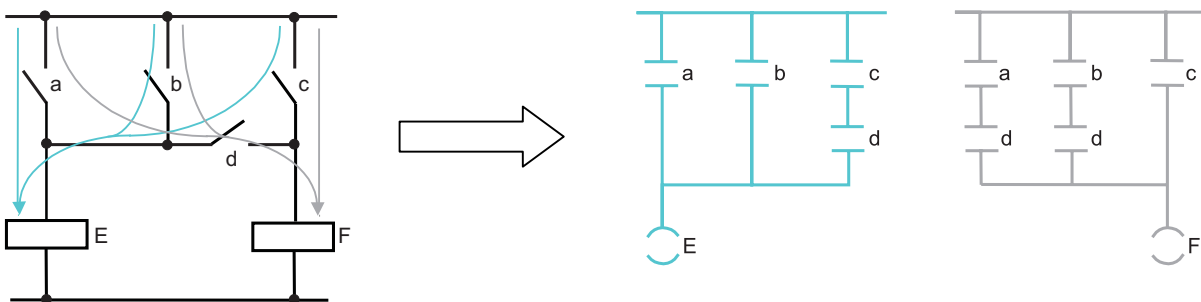

The simple bridge circuit (left) is implemented with two networks. The individual possible current paths are simply split up. For ease of comparison, we have likewise arranged the ladder diagram vertically.

### 2) Complex bridge circuit

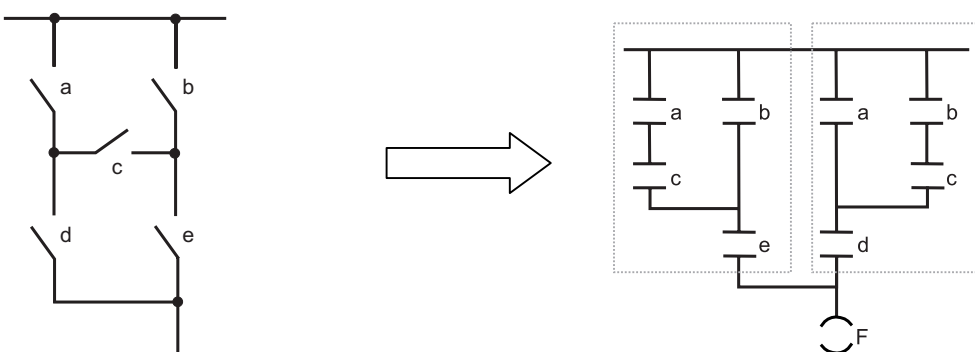

The two possible current paths have been converted again and recombined. On the one hand, a,c parallel b, on the other b,c parallel a. For ease of comparison, we have arranged the ladder diagram vertically.

In new projects, avoid using the bridge circuit in the circuit diagram where possible! Think "in ladder diagram" right from the start.



## Diode Circuit

When diodes have been used in "old" circuit diagrams converting them into ladder diagram terms is not an altogether simple matter.

Since diodes represent connection lines in principle but only conduct current in one direction, a similar solution is adopted here as with the bridge circuit. For ease of comparison with the circuit diagram, the ladder diagram is arranged vertically again.

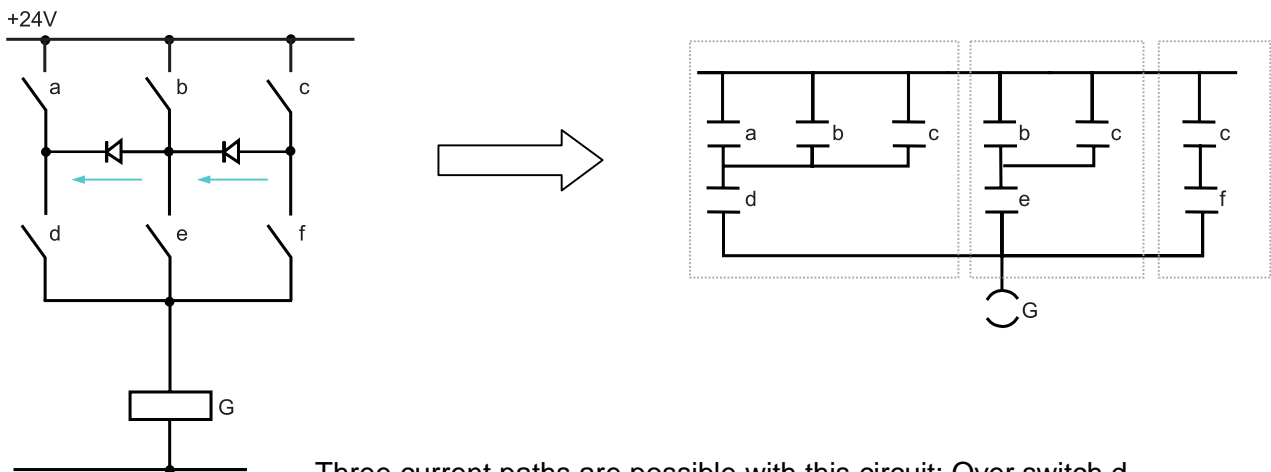

Three current paths are possible with this circuit: Over switch d, switch e and switch f.

The current through the diodes can only flow from b to d or from c to e.

The three current paths result in the three framed sub-networks in the ladder diagram solution. Since switches d, e and f are on the same rail as output G, these three sub-networks have also been linked to form one network.



## Changeover Switch

Changeover switches should likewise not cause you any problem when you are converting a circuit diagram into a ladder diagram. This transformation is explained briefly below.

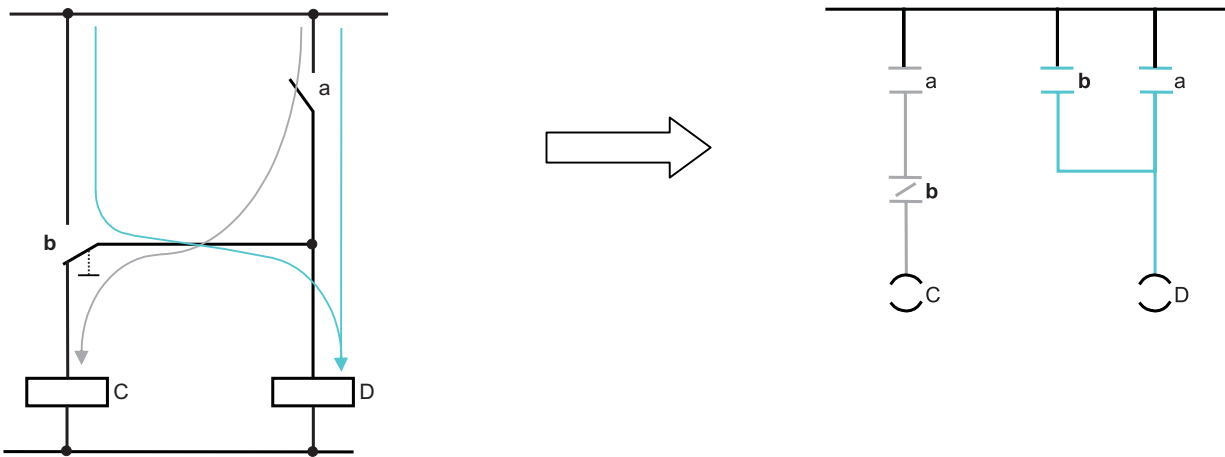

The current path is graphically highlighted.

Changeover switch b is then divided into a normally closed (NC) contact that is switched in series with a and contributes to the effect at output C, or a normally open (NO) contact that takes effect in parallel with a and switches D.

In this way it is in principle possible to convert a changeover switch using an NC contact and an NO contact with the same input address in the ladder diagram.



# Notes





# Index A...I

This index contains the most important terms in programming the S7-200. You will find brief explanations of the abbreviations used in the Primer as well as some cross references to the One Hour Primer.

The following symbol is used in the Index:

1h- References to pages in the 1-Hour Primer

## A

## B

Basics of the sequencer: 39-42  
 Binary: Representation of numbers in bits (two possible values, 0 or 1)  
 Bit memories: 25+  
 Bit: Binary digit: 6  
 Bridge circuit: A1  
 Byte: 8-bit wide value: 1h- 48

## C

Coil: Representation for an output element in the ladder diagram (comparable with a contactor): 17  
 CPU: Central Processing Unit, e.g. the S7-200  
 Current flow in the ladder diagram: 7

## D

Data block: Variable memory of the S7-200, values for use in the control program can be stored here  
 DB1: Data block of the S7-200  
 Diode circuit: A2  
 DIV: Arithmetic division e.g. with text displays, operator panels and touch panels

## E

Edges: 21,22  
 END: Program end statement 31  
 Entering comments: 36 +

## F

## G

## H

HMI: Human-machine interface

## I

I: Input, e.g. I0.0  
 IB: Input byte (8 bits), e.g. IB0  
 Insert network: 32  
 Inserting elements: 1h- 30  
 IW: Input word (16 bits), e.g. IW0



## Index K...S

**K****L**

Ladder diagram: 1h- 25  
 Ladder status: 7, 1h- 26  
 Latching function solution: 15 +  
 Latching: 13 +

**M**

MB: Memory byte (8 bits)  
 MD: Memory double-word (32 bits)  
 Mode selector switch: Switch on the S7-200 with three settings: STOP, TERM, RUN.  
 MW: Memory word (16 bits)

**N**

Normally-closed (NC) contact: 14, 15  
 Normally-open (NO) contact: 8

**O**

OB1: Organization block of the S7-200  
 Off-delay timer solution: 29 +  
 Off-delay timer: 29 ff.  
 On-delay timer: 1h- 35  
 On-line Help: 8  
 Organization block:  
 contains the cyclically executed user program of the controller

**P**

PIQ: Process-image output table: 10  
 PII: Process-image input table: 9  
 PLC: Programmable logic controller.  
 Process-image: A PLC program works on an I/O image. At the start of the cycle, the input image is read in and at the end of the cycle the output image is transferred to the actual outputs: 9 +  
 Pulse-operated switch solution: 21 +  
 Pulse-operated switch: 21 +

**R**

Reset, Set: 16 +  
 RET: Return, end subroutine  
 Retentivity: 23  
 RUN: Position of the S7-200's mode selector switch for manual startup/restart of the controller

**S**

Safety aspects: 19  
 Saving the program: 1h- 41  
 SBR: Subroutine,  
 Semi-automatic controller: Controller that can execute certain sequences autonomously but depends on user inputs at other points.  
 Sequencer solution: 39 +  
 Sequencer: Usually self-contained sequence of steps that is processed step-by-step in a sequential control: 39 +  
 Sequential control: Control that derives steps from events or makes transitions between steps. These, in turn, activate prescribed actions.  
 Set, reset: 17 +  
 SMB: Special memory byte (8 bits), e.g. SMB28  
 SMB28: Potentiometer of the S7-200  
 SMD: Special memory double-word (32 bits)  
 SMW: Special memory word (16 bits)  
 Status in the ladder diagram: 1h- 26  
 Status: Permits monitoring of a process on the program level or in a special status table. Useful for test and diagnostics.  
 Step flag: 41  
 STL: Statement list  
 STOP: Position of the S7-200's mode selector switch for manual stopping of the controller.



## Index T...Z

**T**

T37 (Timer): 29 +

TERM: Position of the S7-200's mode selector switch. Lets you influence the controller from STEP 7-Micro/WIN

Timer

TON: S7-200 time switch, also called timer:  
1h- 36 f.

TONR: Latching on-delay timer

Training model: 1h- 7

Transition condition: 40

True, untrue: 6

Timer

TON: S7-200 time switch, also called timer:  
1h- 36 f.

TONR: Latching on-delay timer

**U**

Untrue, true: 6

**V**

V: Variable bit, e.g. V0.0

VB: Variable byte, e.g. VB0

VD: Variable double-word, e.g. VD45

V memory: Data block in the S7-200

VW: Variable word, e.g. VW45

**W**

Word: A value represented by 2 bytes (16 bits).

Working with sequencers: 45 ff.

**X**

XOR: Exclusive OR, logic operation that switches only in the case of different states (antivalency) at the input

**Z**

Z0: Simple counter (CTU)

To  
Siemens AG  
A&D AS MVM  
Gleiwitzer Str. 555

Fax: +49 911 895-2786

90475 Nuernberg  
Germany

**Response to the "Two-Hour Primer"**

Dear user of the Micro PLC S7-200,

We created the Two-Hour Primer so that, building on the One-Hour Primer, you can learn to use the Micro PLC S7-200 within a very short time.

We are sure that you will easily be able to solve typical control tasks with this primer. However, if you do have any suggestions, it is important to us to hear your opinion.

Please send us this form, stating your name and address so that we can contact you directly.

Thank you

A&D AS MVM

---

**Suggestions, Improvements, Feedback**

From

Name \_\_\_\_\_ Position \_\_\_\_\_

Company \_\_\_\_\_ Telephone \_\_\_\_\_

Street \_\_\_\_\_ Place \_\_\_\_\_

My suggestions:

---

---

---

---

---

---

---

