

Product Information

SIMATIC S7-300

Digital Input Module SM 321; DI 16 X 48-125 VDC

Release

X|2
3|4

New Digital Input Module Available

The S7-300 Digital Input Module SM 321; DI 16 X 48-125 VDC has been added to the S7-300 family. The order number for this module is 6ES7 321-1CH20-0AA0.

This product information includes details about the characteristics and technical specifications of the SM 321; DI 16 X 48-125 VDC Module. Refer to the *S7-300 Installation and Hardware Manual* for more information about the S7-300 product family.

Additional Assistance

For assistance in answering technical questions, for training on this product, or for ordering, contact your Siemens distributor or sales office.

Digital Input Module SM 321; DI 16 X 48-125 VDC

Order Number

6ES7 321-1CH20-0AA0

Characteristics

The SM 321; DI 16 × 48-125 VDC features the following characteristics:

- 16 inputs, isolated in groups of 8
- Rated input voltage 48 to 125 VDC
- Suitable for switches and two / three / four-wire BEROs (proximity switches).

Terminal Assignment and Block Diagram of the SM 321; DI 16 X 48-125 VDC

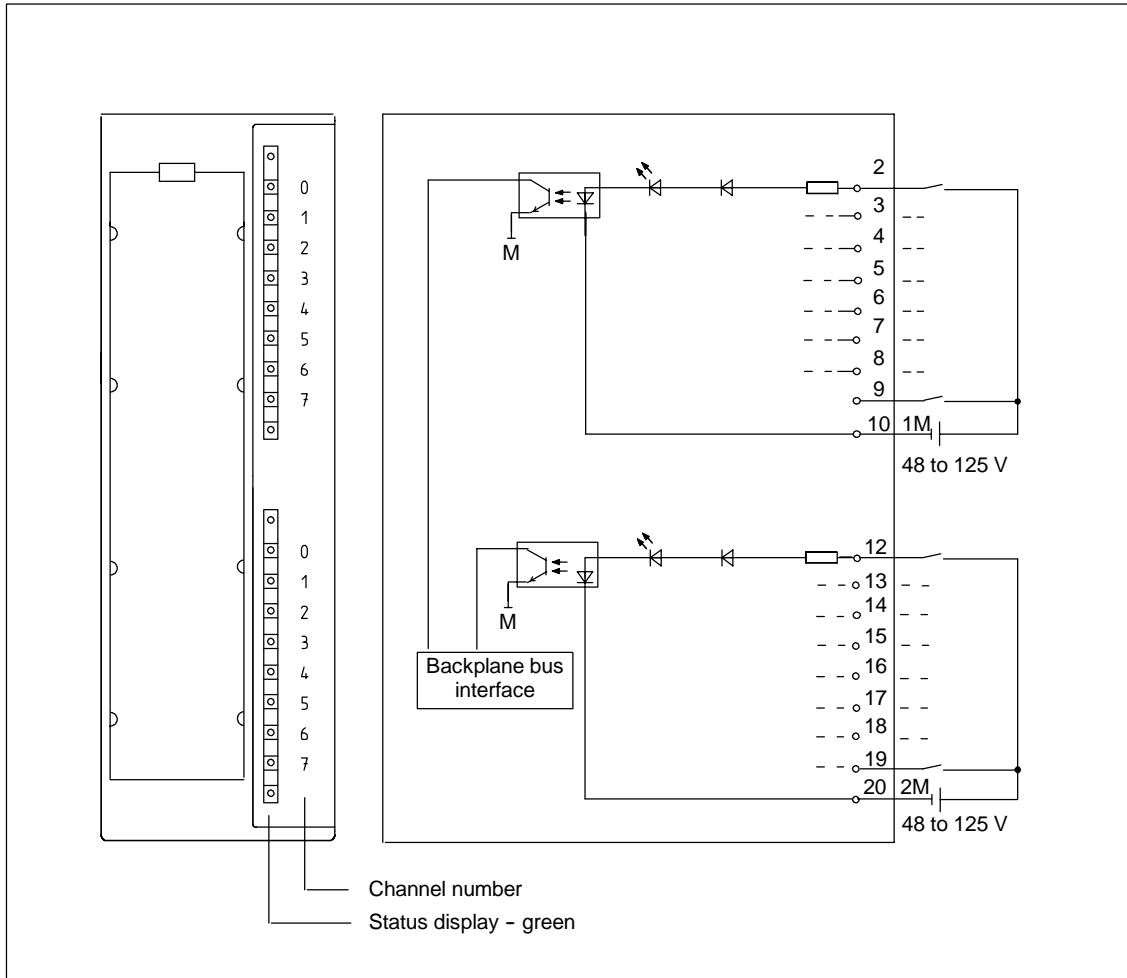

Figure 1 Module View and Block Diagram of the SM 321; DI 16 × 48-125 VDC

Technical Specification of the SM 321; DI 16 × 48-125 VDC

Dimensions and Weight		Status, Interrupts, Diagnostics	
Dimensions W × H × D (in millimeters)	40 × 125 × 120	Status display	Green LED per channel
Weight	Approx. 200 g	Interrupts	None
Data for Specific Module		Diagnostic functions	None
Supports clocked operation	No	Sensor Selection Data	
Number of inputs	16	Input voltage	
Length of cable		• Rated value	48 VDC to 125 VDC
• Unshielded	max. 600 m	• For signal "1"	30 V to 146 V
• Shielded	max. 1000 m	• For signal "0"	-146 V to 15 V
Voltages, Currents, Potentials		Input current	
Number of inputs that can be triggered simultaneously at U _E	Up to 60 V Up to 146 V	• At signal "1"	typ. 3.5 mA
• Horizontal installation		Input delay	
Up to 50 °C	8 8	• At "0" to "1"	0.1 ms to 3.5 ms
Up to 60 °C	8 6	• At "1" to "0"	0.7 ms to 3.0 ms
• Vertical configuration		Input characteristic curve	According to IEC 61131, type 1
Up to 40 °C	8 8	Connection of Two-Wire BEROs	Possible
Isolation		• Permitted bias current	max. 1 mA
• Between channels and backplane bus	Yes		
• Between the channels	Yes		
In groups of	8		
Permiss. potential differences			
• Between the different circuits	146 VDC / 132 VAC		
Insulation tested with	1500 VDC		
Current consumption			
• From the backplane bus	max. 40 mA		
Power dissipation of the module	typ. 4.3 W		