

---

## Operating Instructions

---

### MICRO PANEL

---

XV400 5.7"/8.4"; MC2 5.7"

---



Document M000746-06  
Edition 04/2008

**Manufacturer****Product Company**

Micro Innovation AG  
Spinnereistrasse 8-14  
CH-9008 St. Gallen  
Switzerland

Tel. +41 (0) 71 243 24 24  
Fax +41 (0) 71 243 24 90  
info@microinnovation.com  
www.microinnovation.com

**Sales Company**

Micro Innovation GmbH  
Nideggerstrasse 6-10  
D-53115 Bonn  
Germany

Tel. +49 (0) 228 602 2020  
Fax +49 (0) 228 602 1713  
info@microinnovation.com  
www.microinnovation.com

**Service/Repair Center**

Micro Innovation GmbH  
Carl-Benz-Strasse 19  
D-78224 Singen  
Germany

Tel. +49 (0) 7731 7896 110  
Fax +49 (0) 7731 7896 101  
servicecenter@microinnovation.com  
www.microinnovation.com

**Original instructions**

The German version of this document is the original instructions.

**Translation of the original instructions**

All non-German editions of this document are translations of the original instructions.

**Editor**

Monika Jahn

**Brand and product names**

All brand and product names are trademarks or registered trademarks of the owner concerned.

**Copyright**

© Micro Innovation AG, CH-9008 St. Gallen

All rights reserved, also for the translation.

None of this document may be reproduced or processed, duplicated or distributed by electronic systems in any form (print, photocopy, microfilm or any other process) without the written permission of Micro Innovation AG, St. Gallen.

Subject to modifications.

## Contents

<b>1.</b>	<b>General</b> .....	<b>7</b>
1.1	Purpose of these Operating Instructions.....	7
1.2	Additional documentation.....	7
<b>2.</b>	<b>Device description</b> .....	<b>9</b>
2.1	Device names.....	9
2.2	Function.....	9
2.3	Intended use.....	9
2.4	Device versions.....	9
2.5	Scope of delivery.....	11
2.5.1	Scope of delivery for devices with resistive touch and standard front.....	11
2.5.2	Scope of delivery for devices with infra-red touch and standard front.....	11
2.5.3	Scope of delivery for devices with 4-hole front.....	12
2.5.4	Scope of delivery for devices with stainless steel front.....	12
2.6	Accessories.....	12
2.7	Designation.....	13
<b>3.</b>	<b>Safety regulations</b> .....	<b>15</b>
3.1	General.....	15
3.2	Meaning of symbols.....	15
3.3	Mandatory requirements, personnel.....	16
3.3.1	Work safety.....	16
3.3.2	Qualification of personnel.....	16
3.3.3	Operating Instructions.....	16
3.3.4	Installation, maintenance and disposal.....	16
3.3.5	Prohibited use.....	16
3.3.6	Requirements for proper operation.....	17
3.4	Device related hazards.....	18
<b>4.</b>	<b>Operating and indication elements</b> .....	<b>21</b>
4.1	Operating and indication elements on the front.....	21
4.2	Operating elements on the service side.....	22
4.3	Indication elements on the service side.....	23
<b>5.</b>	<b>Installation</b> .....	<b>25</b>
5.1	Safety regulations.....	25
5.1.1	Qualification of personnel.....	25
5.2	Requirements for the place of installation.....	26
5.2.1	Requirements for the mounting position.....	26
5.3	Cable preparation.....	27
5.3.1	Overview of interfaces.....	28
5.3.2	Preparation of cables with D-Sub connector.....	29
5.3.3	Power supply.....	31
5.3.4	System Port (RS232).....	32
5.3.5	Ethernet.....	33
5.3.6	USB Device.....	34

5.3.7	USB Host .....	34
5.3.8	CAN.....	35
5.4	Mounting .....	37
5.4.1	Fitting the communication module in the device .....	38
5.4.2	Mounting a device with standard front .....	40
5.4.3	Mounting a device with 4-hole front .....	43
5.4.4	Mounting a device with stainless steel front (standard mounting, mounting to IP65) .	45
5.4.5	Mounting a device with stainless steel front (mounting to IP69K).....	48
<b>6.</b>	<b>Operation .....</b>	<b>51</b>
6.1	Safety regulations .....	51
6.1.1	Qualification of personnel.....	51
6.2	Starting the device .....	52
6.3	Switching off the device .....	54
<b>7.</b>	<b>Maintenance and service.....</b>	<b>55</b>
7.1	Safety regulations .....	55
7.1.1	Qualification of personnel.....	55
7.2	Maintenance.....	56
7.2.1	Cleaning the resistive touch .....	56
7.2.2	Recalibrating a resistive touch .....	56
7.2.3	Cleaning the infra-red touch.....	57
7.2.4	Recalibrating the infra-red touch .....	58
7.2.5	Battery.....	58
7.3	Service .....	59
7.3.1	Repairs.....	59
7.4	Troubleshooting and fault rectification .....	60
<b>8.</b>	<b>Storage, transport and disposal .....</b>	<b>63</b>
8.1	Safety regulations .....	63
8.1.1	Qualification of personnel.....	63
8.2	Storage.....	63
8.3	Transport.....	63
8.4	Disposal .....	64
<b>9.</b>	<b>Technical data .....</b>	<b>65</b>
9.1	Dimensions and weights .....	65
9.1.1	5.7" devices with standard or stainless steel front .....	65
9.1.2	5.7" devices with 4-hole front .....	66
9.1.3	8.4" devices.....	67
9.2	Display .....	68
9.2.1	5.7" devices XV-432-57; MC2-432-57 and XV-442-57; MC2-442-57 .....	68
9.2.2	5.7" devices XV-450-57 and XV-460-57 .....	68
9.2.3	8.4" devices.....	69
9.3	Touch sensor .....	69
9.3.1	Devices with resistive touch .....	69
9.3.2	Devices with infra-red touch.....	69
9.4	System .....	70
9.5	Interfaces .....	70

9.5.1	Power supply.....	71
9.6	IP protection classes.....	72
9.7	Approvals and declarations.....	72
9.8	Applicable standards and regulations.....	73
9.9	Ambient conditions.....	73



## 1. General

### 1.1 Purpose of these Operating Instructions

These Operating Instructions contain the information required for the correct and safe use of the MICRO PANELs XV400 5.7"/8.4"; MC2 5.7". The Operating Instructions are part of the devices and must therefore be kept nearby.

These Operating Instructions describe all aspects of the devices: transport, installation, commissioning, operation, maintenance, storage and disposal.

The operating system and the application software are not described.



**Read the Chapter 3. Safety regulations, 15, before working with the device. These contain important information for your personal safety. This chapter must be read and understood by all persons working with this device.**

#### WARNING



#### Incomplete copy of these Operating Instructions

Working with individual pages of these Operating Instructions may cause damage to property or personnel by failure to observe safety-related information.

▶ Always work with the complete document.

#### Comments about these Operating Instructions

Please send any comments, recommendations or suggestions relating to these Operating Instructions to [info@microinnovation.com](mailto:info@microinnovation.com).

### 1.2 Additional documentation

The following documents may be helpful in the use of the device in addition to these Operating Instructions. These can be downloaded from our home page ([www.microinnovation.com/en](http://www.microinnovation.com/en), «DOWNLOADS» section).

[1] M000174  
System Description Windows CE  
(operation of the Windows CE operating system on a MICRO PANEL)

[2] M000138  
System Description Networks in Brief  
(information on networks in general and on the integration of PCs and MICRO PANELs in networks)



## 2. Device description

### 2.1 Device names

XV400 5.7"/8.4"; MC2 5.7" are two different names of equivalent products.

### 2.2 Function

MICRO PANELs XV400 5.7"/8.4"; MC2 5.7" can be used exclusively as HMI devices or also as PLC devices.

### 2.3 Intended use

MICRO PANELs XV400 5.7"/8.4"; MC2 5.7" are primarily used in machine and system building as well as in building services management systems. They are designed exclusively for the visualization, operation and control of machines, systems and buildings. Any other use must be agreed beforehand with the manufacturer.

### 2.4 Device versions

MICRO PANELs XV400 5.7"/8.4"; MC2 5.7" are available in the following versions:

Version with	XV400 type	MC2 type
Resistive touch 5.7", CSTN LCD display, standard front	XV-432-57CQB-1-1x	MC2-432-57CQB-1-1x
Infra-red touch 5.7", CSTN LCD display, standard front	XV-442-57CQB-1-1x	MC2-442-57CQB-1-1x
Infra-red touch 5.7", CSTN LCD display, 4-hole front	XV-442-57CQB-1-2x	MC2-442-57CQB-1-2x
Infra-red touch 5.7", CSTN LCD display, stainless steel front	XV-442-57CQB-1-5x	MC2-442-57CQB-1-5x
Resistive touch 5.7", TFT LCD display, standard front	XV-450-57TQB-1-1x	–
Infra-red touch 5.7", TFT LCD display, standard front	XV-460-57TQB-1-1x	–
Infra-red touch 5.7", TFT LCD display, stainless steel front	XV-460-57TQB-1-5x	–
Infra-red touch 8.4", TFT LCD display, standard front	XV-460-84TVB-1-1x	–

Tab. 1 Device versions

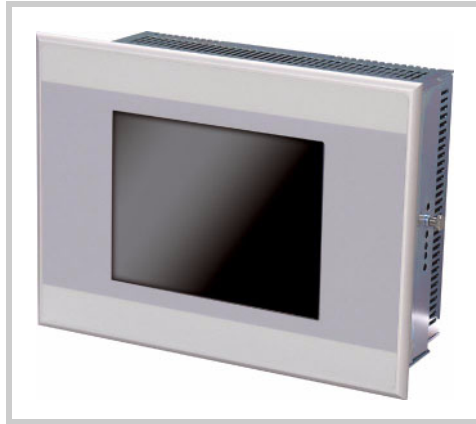

Fig. 1 5.7" device with resistive touch and standard front



Fig. 2 5.7" device with infra-red touch and standard front

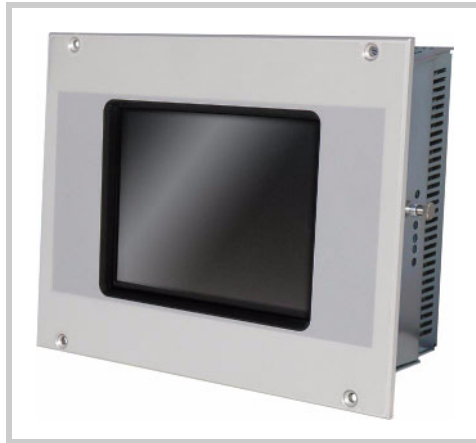

Fig. 3 5.7" device with infra-red touch and 4-hole front

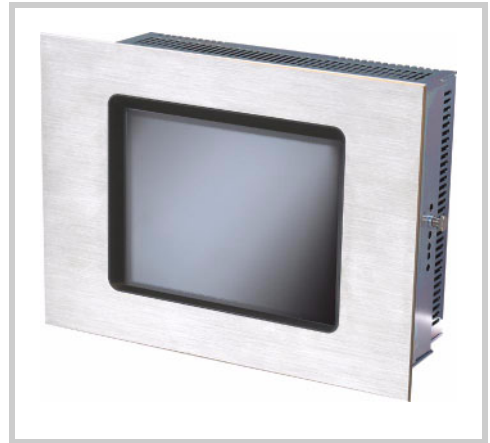

Fig. 4 5.7" device with infra-red touch and stainless steel front



Fig. 5 8.4" device

## 2.5 Scope of delivery

The accessories supplied with the MICRO PANELs XV400 5.7"/8.4"; MC2 5.7" depend on the device version.

### 2.5.1 Scope of delivery for devices with resistive touch and standard front

Qty	Designation
1	MICRO PANEL: <ul style="list-style-type: none"> <li>■ XV-432-57CQB-1-1x or</li> <li>■ MC2-432-57CQB-1-1x or</li> <li>■ XV-450-57TQB-1-1x</li> </ul>
1	Set of retaining brackets (4 retaining brackets with threaded pin)
1	Sealing strip for mounting the device
1	Power supply connector
1	CF slot cover (fitted)
1	Slot cover (fitted)
1	Touch pen

Tab. 2 Scope of delivery for devices with resistive touch and standard front

### 2.5.2 Scope of delivery for devices with infra-red touch and standard front

Qty	Designation
1	MICRO PANEL: <ul style="list-style-type: none"> <li>■ XV-442-57CQB-1-1x or</li> <li>■ MC2-442-57CQB-1-1x or</li> <li>■ XV-460-57TQB-1-1x or</li> <li>■ XV-460-84TVB-1-1x</li> </ul>
1	Set of retaining brackets (4 retaining brackets with threaded pin)
1	Sealing strip for mounting the device
1	Power supply connector
1	CF slot cover (fitted)
1	Slot cover (fitted)

Tab. 3 Scope of delivery for devices with infra-red touch and standard front

## 2.5.3

## Scope of delivery for devices with 4-hole front

Qty	Designation
1	MICRO PANEL: ■ XV-442-57CQB-1-2x or ■ MC2-442-57CQB-1-2x
4	Countersunk screws for mounting the device
1	Front seal for mounting the device
1	Power supply connector
1	CF slot cover (fitted)
1	Slot cover (fitted)

Tab. 4 Scope of delivery for devices with 4-hole front

## 2.5.4

## Scope of delivery for devices with stainless steel front

Qty	Designation
1	MICRO PANEL: ■ XV-442-57CQB-1-5x or ■ MC2-442-57CQB-1-5x or ■ XV-460-57TQB-1-5x
2	Sets of retaining brackets (4 retaining brackets with threaded pin each)
1	Seal for mounting the device
1	Power supply connector
1	CF slot cover (fitted)
1	Slot cover (fitted)

Tab. 5 Scope of delivery for devices with stainless steel front

## 2.6

## Accessories

Different accessories are available.



**Order the accessories required from your supplier.**

- **Required accessories for:**
  - **Mounting with increased protection class:**  
See Chapter 9.6 IP protection classes, 72.
  - **Use in a potentially explosive atmosphere:**  
See Chapter 9.7 Approvals and declarations, 72.
- **Required communication module**

## 2.7

### Designation

#### Nameplate

A nameplate is fixed on the rear of the device in order to identify it. The nameplate contains the following information:

- Manufacturer address
- Type designation
- Power supply required
- Article no.
- Serial no.
- Time of manufacturing (week/year)
- Approval marks
- Arrangement of interfaces and operating elements
- Permissible mounting options (top edge «Top»)

#### Support

To ensure fast and optimum support always provide the support personnel with the following information on the nameplate:

- Article no.
- Serial no.



## 3. Safety regulations

### 3.1 General

Hazards may still occur even though the device meets the current state of the art and complies with all recognized safety requirements.

The device must only be installed and commissioned in perfect technical condition and in compliance with these Operating Instructions.

 **Read this chapter, before working with the device. This contains important information for your personal safety. This chapter must be read and understood by all persons working with this device.**

### 3.2 Meaning of symbols

The following symbols are used in these Operating Instructions according to the hazard level described:

#### DANGER



##### Signal word DANGER

Indicates an imminently hazardous situation which, if not avoided, will result in death or serious injury.

#### WARNING



##### Signal word WARNING

Indicates a potentially hazardous situation which, if not avoided, could result in death or serious injury.

#### CAUTION



##### Signal word CAUTION

Indicates a potentially hazardous situation which, if not avoided, could result in minor or moderate injury or in material damage.

 **Indicates important information not related to safety.**

The danger symbol used and the text indicate the actual danger and the related preventative measures.

### 3.3 Mandatory requirements, personnel

#### 3.3.1 Work safety

All applicable work safety regulations (in-house and national) must be observed.

#### 3.3.2 Qualification of personnel

It must be ensured that only suitably qualified persons work with the device. These persons must be informed of all hazards and risks associated with the device.

The following persons must be suitably qualified according to the work to be completed:

- Installation:  
Automation specialists
- General operation:  
Operating personnel instructed in the application
- Maintenance and service:  
Persons suitably qualified for the work to be completed
- Storage:  
Persons without special knowledge
- Transport:  
Persons with a specialist knowledge of transport (in particular how to prevent damage in transit)
- Disposal:  
Persons with a specialist knowledge of proper disposal (also about the proper disposal of harmful substances)

#### 3.3.3 Operating Instructions

It must be ensured that any person working with the device in any phase of its lifespan has read and understood the relevant sections of the Operating Instructions.

##### WARNING



##### Incomplete copy of these Operating Instructions

Working with individual pages of these Operating Instructions may cause damage to property or personnel by failure to observe safety-related information.

- ▶ Always work with the complete document.

#### 3.3.4 Installation, maintenance and disposal

It must be ensured that the device is properly connected, mounted, maintained and disposed of in compliance with all relevant standards and safety regulations.

#### 3.3.5 Prohibited use

The implementation of safety functions (relating to the protection of personnel and machinery) using the device is prohibited.

### 3.3.6

#### Requirements for proper operation

The following points must be observed so that the device meets the contractual requirements:

- Only qualified personnel may work with the device.
- These persons must have read the Operating Instructions and must observe the requirements described.
- The ambient conditions stated must be observed. See Chapter 9.9 Ambient conditions,  73.
- The maintenance work must be carried out correctly.

No liability is accepted for damage, consequential damage and accidents caused by the following:

- Failure to observe work safety regulations
- Failure or malfunction of the device
- Improper handling or use
- Failure to observe the Operating Instructions
- Conversions, modifications and repairs to the device



**Repairs, see Chapter 7.3.1 Repairs,  59.**

## 3.4

## Device related hazards

**DANGER****Explosion hazard**

Death, serious injury or material damage may occur if an electrical plug connection is removed in a potentially explosive atmosphere during operation.

- ▶ Only use the device in the following environments:
  - Environments not subject to explosion hazards
  - Potentially explosive atmosphere, Zone 22 (according to ATEX 94/9/EC)
- ▶ Only operate the device in potentially explosive atmospheres if it is correctly mounted.
- ▶ Switch off the device before removing the plug connections

**WARNING****Live parts in the device**

When the device is opened, there is a risk of electric shock if live parts are touched.

- ▶ The device must not be opened.

**WARNING****Potential equalization currents**

Large equalization currents between the protective ground systems of different devices may cause operational malfunctions due to signal interference and may even cause fires.

- ▶ If necessary, a potential equalization conductor should be installed parallel to the cable. This should have a cross-section that is a multiple of the cable shield.

**CAUTION****Sensitive resistive touch surface**

Damage to the resistive touch due to the use of pointed or sharp objects.

- ▶ Only activate the resistive touch with your finger or a touch pen.
- ▶ When wearing gloves, ensure that these are clean. They must not be covered with abrasive dust or sharp particles.

**CAUTION****Electrostatic discharge**

Electrostatic discharge may damage or destroy electronic components.

- ▶ Avoid contact with components (such as connector pins) that are susceptible to electrostatic discharge.
- ▶ Discharge (by touching a grounded metal object) any static charge accumulated in your body before touching the device.

**CAUTION****Data loss**

During a write operation, the CF card may lose data or may be destroyed if it is removed or if there is a power failure.

- ▶ Always secure CF cards with the CF slot cover.
- ▶ Avoid write operations to CF cards. Reasons:
  - The number of write cycles possible on CF cards is limited.
  - A power failure during write operations will most likely lead to loss of data.
- ▶ Only remove the CF card when the device is in a de-energized state.
- ▶ Before switching off, ensure that no software write operations to the CF card are in progress («CF ACT» LED must not be lit).

**CAUTION****Device condensation**

If the device is or was exposed to climatic changes (temperature fluctuation, air humidity) moisture can form on or in the device (device condensation). In this case, there is a risk of short-circuit.

- ▶ The device must **not** be switched on when device condensation is present.
- ▶ If condensation is present on the device, or if it was exposed to temperature fluctuations, it must be allowed to adjust to room temperature (do not expose the device to the direct heat of heating devices) prior to commissioning.

**CAUTION****Cleaning the device**

Damage to the device due to the use of pointed or sharp objects or by liquids.

- ▶ Do not use any pointed or sharp objects (e.g. knife) for cleaning.
- ▶ Do not use any aggressive or abrasive cleaning agent or solvent.
- ▶ Avoid any liquid entering the device (risk of short-circuit).



## 4. Operating and indication elements

### 4.1 Operating and indication elements on the front



Fig. 6 Operating and indication elements on the front (figure shows device with infra-red touch)

The device has the following operating and indication elements on the front:

Element	Function
A Touch sensor	Detection of the actuation of the operating elements shown on the display. <ul style="list-style-type: none"> <li>■ Resistive touch: These devices are operated by touching the operating elements with your finger or with a touch pen.</li> <li>■ Infra-red touch: These devices are operated by interrupting the infra-red light matrix with your finger or a suitable object (min. <math>\varnothing</math> 7 mm). It is not necessary to touch the infra-red touch protective panel.</li> </ul>
B Display	Display operating and indication elements.

Tab. 6 Operating and indication elements on the front

## 4.2 Operating elements on the service side

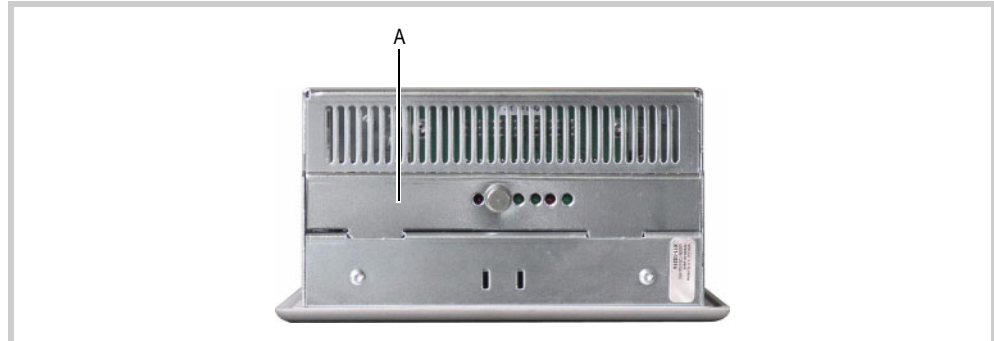

Fig. 7 Operating elements on the service side (CF slot cover fitted)

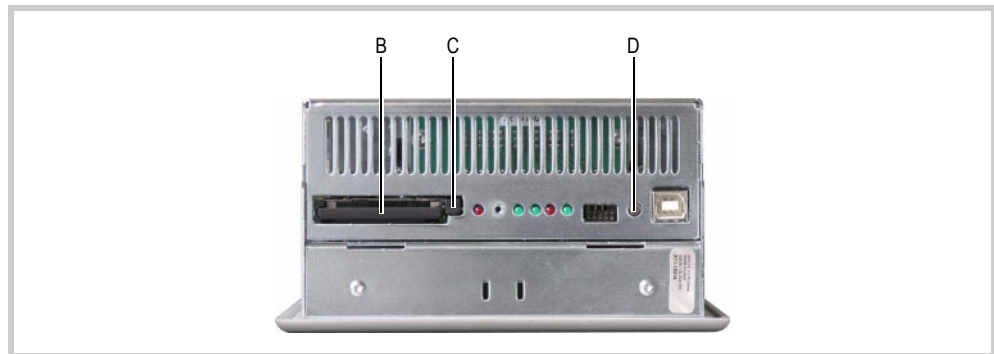

Fig. 8 Operating elements on the service side (CF slot cover removed)

The device has the following operating elements on the service side:

Element	Function
A CF slot cover	Fastening the CF card in the CF slot.
B CF slot 0	Slot for CF card with operating system and normally with PLC and visualization projects.
C Ejector button	Ejecting the CF card.
D Control button	Function depends on the software used.

Tab. 7 Operating elements on the service side

## 4.3

## Indication elements on the service side

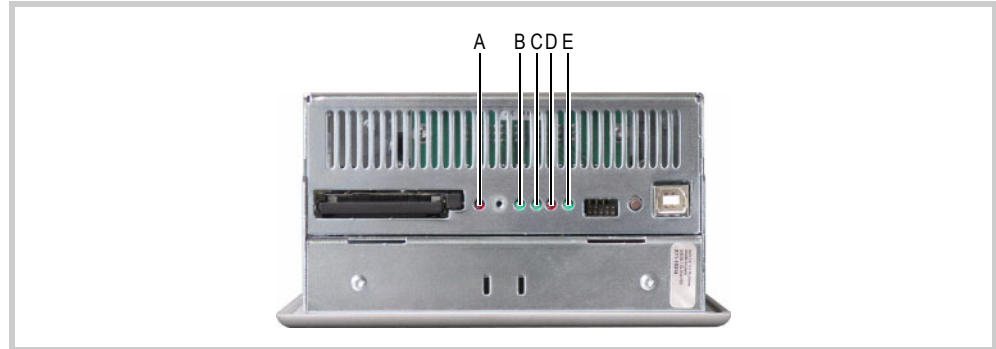

Fig. 9 Indication elements on the service side

The device has the following indication elements on the service side:

LED	Function
A CF ACT (red)	Lit if the CF card is accessed.
B CAN ACT (green)	Lit if data is transferred via the CAN interface.
C TOUCH ACT (green)	<ul style="list-style-type: none"> <li>■ Dark during boot up.</li> <li>■ Lit when the touch sensor is ready.</li> <li>■ Flashes when actuating the touch sensor.</li> </ul>
D TOUCH ERROR (red)	<ul style="list-style-type: none"> <li>■ Lit during boot up.</li> <li>■ Dark when the touch sensor is ready.</li> <li>■ Lit in the event of errors.</li> <li>■ Flashes if the infra-red frame is contaminated and has to be cleaned (cleaning the infra-red touch, → Chapter 7.2.3, 57).</li> <li>■ Flashes if the resistive touch is incorrectly calibrated (touch calibration, → Document «M000174»).</li> </ul>
E SUPPLY OK (green)	Lit if all internal system voltages are present.

Tab. 8 Indication elements on the service side



## 5. Installation

### 5.1 Safety regulations



 Read the Chapter 3. Safety regulations, 15, before installing and commissioning the device. These contain important information for your personal safety.

#### 5.1.1 Qualification of personnel

The device must only be installed and commissioned by automation specialists.

## 5.2



### Requirements for the place of installation

- Approvals:  
The device must only be used in locations that are approved for the device. See the markings on the nameplate and Chapter 9. Technical data,  65.
- Power supply:  
The power supply must comply with the requirements stated in Chapter 9.5.1 Power supply,  71.

### 5.2.1

#### Requirements for the mounting position

The device is designed for mounting in control cabinets, control panels or control desks. It can be mounted horizontally or vertically. The following requirements must be fulfilled when selecting a suitable mounting position:

- The display should not be exposed to direct sunlight (the UV component of sunlight reduces the lifespan of the device and disturbs the infra-red touch sensor).
- If possible, the operating elements on the service side of the device and the cable connections should also still be accessible after the device has been mounted.
- The ambient conditions stated must be observed. See Chapter 9.9 Ambient conditions,  73.
- Sufficient ventilation (cooling) must be ensured by means of:
  - Clearance of at least 3 cm to the ventilation slots
  - Clearance of at least 15 cm from heat radiating components such as heavily loaded transformers
  - The expected temperatures should be within the permissible range. See Chapter 9.9 Ambient conditions,  73.
- Properties of the mounting surfaces:
  - Material thickness at the mounting cutout 2...5 mm (devices with 4-hole front: 2...20 mm)
  - Flatness  $\leq 0.5$  mm (this requirement must also be fulfilled when the device is mounted!)
  - Surface roughness  $R_z \leq 120$



**Special specifications apply to the mounting surfaces of devices with a stainless steel front which have to ensure protection to IP69K (required for cleaning with high-pressure cleaners), see Chapter 5.4.5 Mounting a device with stainless steel front (mounting to IP69K),  48.**

### 5.3

#### Cable preparation

The cables for wiring the device are not supplied with it.

##### WARNING



##### Potential equalization currents

Large equalization currents between the protective ground systems of different devices may cause operational malfunctions due to signal interference and may even cause fires.

- ▶ If necessary, a potential equalization conductor should be installed parallel to the cable. This should have a cross-section that is a multiple of the cable shield.

##### CAUTION



##### Operational malfunctions

Use of unsuitable or improperly prepared cables, as well as incorrect wiring will mean that neither the values stated in the technical data nor the electromagnetic compatibility (EMC) can be ensured.

- ▶ Only use cables prepared by specialists.
- ▶ The cables used must be prepared according to the interface description in these Operating Instructions.
- ▶ The wiring instructions for the relevant interface must be observed when wiring the device.
- ▶ Any generally applicable regulations and standards must be fulfilled.

## 5.3.1

## Overview of interfaces

Connector side:

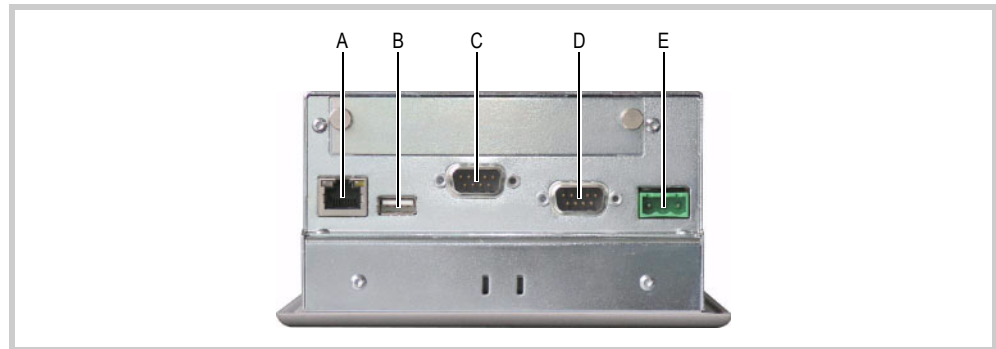

Fig. 10 Connector side of the device

Service side:

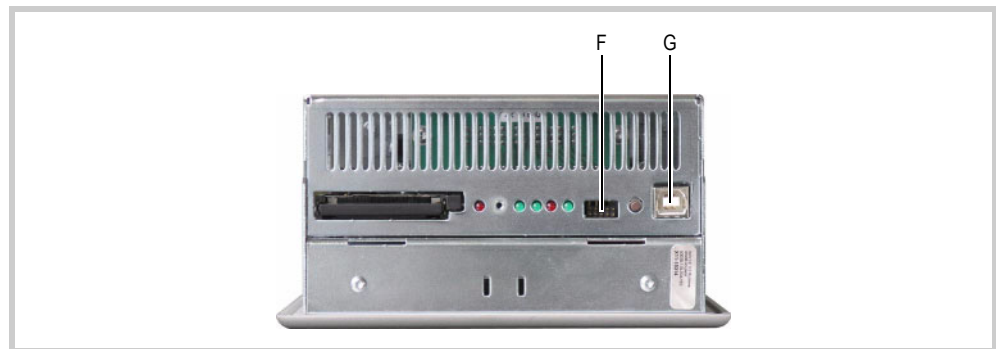

Fig. 11 Service side of the device

Interface	Interface description
A Ethernet	→ Chapter 5.3.5, 33
B USB Host 0	→ Chapter 5.3.7, 34
C CAN	→ Chapter 5.3.8, 35
D System Port	→ Chapter 5.3.4, 32
E Power supply	→ Chapter 5.3.3, 31
F DIAG	Only for service tasks
G USB Device	→ Chapter 5.3.6, 34

Tab. 9 Overview of interfaces

## 5.3.2

## Preparation of cables with D-Sub connector

The preparation of bus cables is an essential factor in ensuring reliable operation and electromagnetic compatibility (EMC).

## Wiring requirements

- The cables must be shielded.
- The cable shield must be made from a copper braid.
- The cable shield must make a low impedance connection with the connector casing over a large contact area. This is achieved by:
  - Use of metal or metallized connector casings with a cable clamp for strain relief.
  - The cable clamp must be screwed securely to the connector.

## Connecting the cable shield

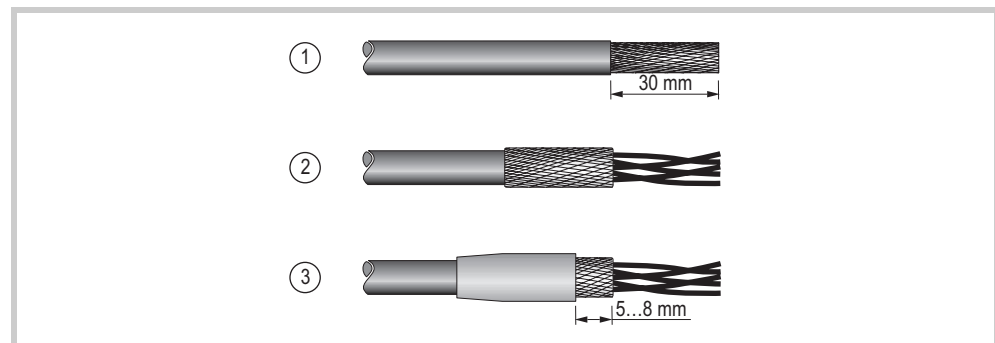

Fig. 12 Connecting the cable shield

- 1 Strip the cable end so that approx. 3 cm of the shield braid is exposed.
- 2 Fold back the shield braid over the cable shield.
- 3 Fit approx. 3 cm of heat shrinkable tubing over the folded back end of the shield braid or use a rubber grommet.
  - 5...8 mm of the shield braid must be exposed at the cable end.
  - The folded back shield braid end must be covered by the heat shrinkable tubing or by the rubber grommet.
- 4 Fit the D-Sub connector to the cable end:
  - The exposed metal shield braid must be clamped to the connector casing with the cable clamp.

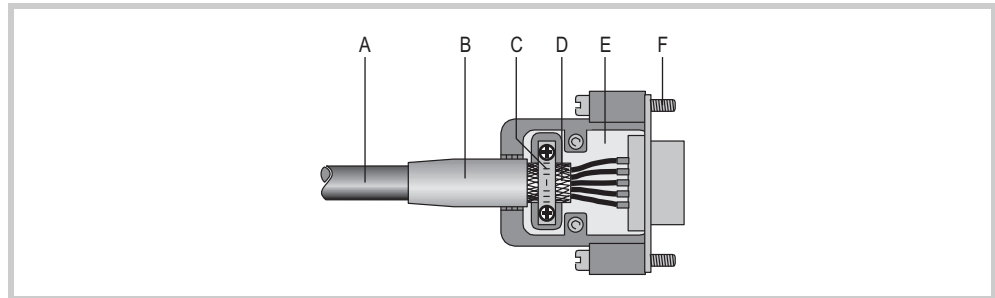



Fig. 13 Cable prepared with D-Sub connector

- |  |                    |
|--|--------------------|
| A Cable with cable sheath                  | D Shield braid     |
| B Heat shrinkable tubing or rubber grommet | E D-Sub connector  |
| C Cable clamp                              | F Fixing screw UNC |

 **The EMC values stated in the technical data (immunity and emission) can only be guaranteed by observing the prescribed cable preparation!**

## 5.3.3

## Power supply

The device is provided with an internal fuse cut-out and is protected against polarity reversal. The GND terminal is connected to both the housing and the 0 V terminal. The device power supply is **not** electrically isolated.

The device requires a 24 VDC power supply from an AC/DC converter with safe isolation (e.g. SELV). For other power supply requirements see Chapter 9.5.1 Power supply, 71.

- SELV (safety extra low voltage):  
Circuit in which no dangerous voltage is present, even in the event of a single fault.

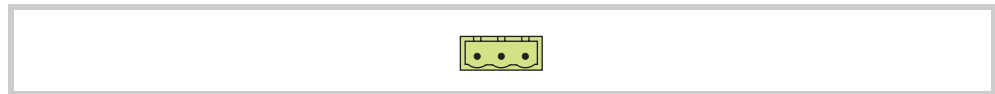

Fig. 14 Power supply interface

## Wiring

- Phoenix Contact MSTB 2.5/3-ST-5.08 connector, Phoenix order no. 1757022 is always supplied with the device.

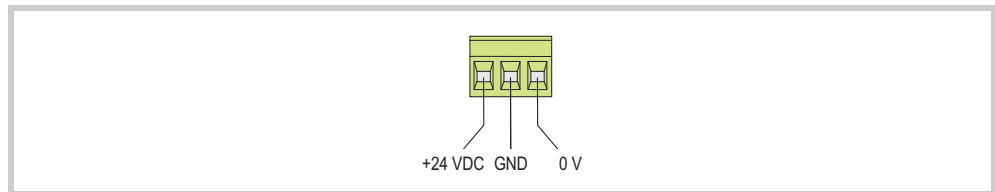

Fig. 15 Phoenix Contact MSTB 2.5/3-ST-5.08 connector (view from the wiring side)

Connection	Assignment
+24 VDC	+24 VDC power supply
GND	Functional ground connected to housing (does not have to be connected)
0 V	0 V power supply (connected to GND)

Tab. 10 Assignment of connector

- The following must be observed when the connector wiring is prepared:

## Preparing the wiring of the connector

Terminal type	Pluggable screw terminal
Cross-section	<ul style="list-style-type: none"> <li>■ min. 0.75 mm<sup>2</sup> / max. 2.5 mm<sup>2</sup> (lead or wire)</li> <li>■ min. AWG18 / max. AWG12</li> </ul>
Stripping length	7 mm

Tab. 11 Preparing the wiring of the connector

## 5.3.4

## System Port (RS232)

The System Port is implemented as a standard RS232 interface. This interface is **not** electrically isolated. The GND pin is directly connected to the housing potential.

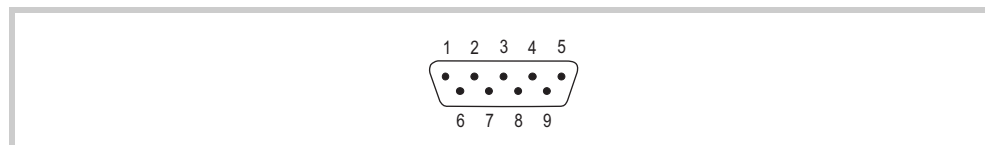

Fig. 16 RS232 interface (9-pin, D-Sub, male, UNC)

Pin	Signal	Assignment
1	DCD	Data Carrier Detected
2	RxD	Receive Data
3	TxD	Transmit Data
4	DTR	Data Terminal Ready
5	GND	Ground
6	DSR	Data Set Ready
7	RTS	Request to Send
8	CTS	Clear to Send
9	RI	Ring Indicator

Tab. 12 Pin assignment of the RS232 interface

## Wiring

- Shielded cables must be used.
- The maximum baud rate depends on the cable length:

Cable length	Max. baud rate
30 m	9600 Bit/s
15 m	19200 Bit/s
10 m	38400 Bit/s
5 m	57600 Bit/s
2.5 m	115200 Bit/s

Tab. 13 Relationship of cable length / baud rate



**When preparing the cables, ensure that there is a low-resistance connection between the cable shield and the connector casing (→ Chapter 5.3.2, 29).**

## 5.3.5

## Ethernet

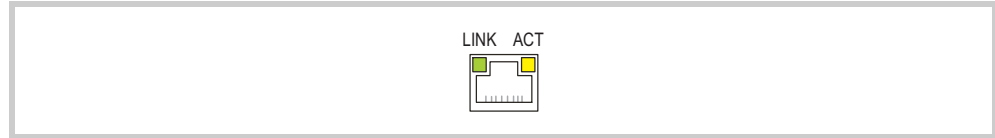

Fig. 17 Ethernet interface (RJ45 socket)

LED	Signal	Meaning
ACT (yellow)	flashes	Ethernet is active (data traffic)
LINK (green)	lit	Active network is connected and detected

Tab. 14 Control LEDs of the Ethernet interface

## Cable

- Use shielded twisted pair cable (STP) for networking:
  - For device to device connection: crossover cable
  - For connecting to the hub/switch: 1:1 patch cable
- Maximum cable length: 100 m.

Ethernet interface in accordance with EIA/TIA 568 TSB-36.

**CAUTION****Forces acting on the Ethernet interface**

Communication can be disturbed and the connection mechanics damaged if the Ethernet interface is exposed to severe vibration or the RJ45 plug connection is pulled.

- ▶ Protect the RJ45 connection from severe vibration.
- ▶ Protect the RJ45 connection from pulling on the socket.

### 5.3.6

#### USB Device

The USB Device interface supports USB 1.1.



Fig. 18 USB Device interface (USB Device, type B)

#### Cable

- Only use shielded USB standard cable.
- Maximum cable length: 5 m.

### 5.3.7

#### USB Host

The USB Host interface supports USB 2.0.

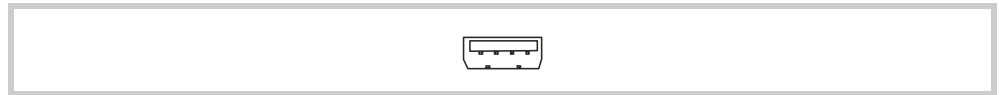

Fig. 19 USB Host interface (USB Host, type A)

#### Cable

- Only use shielded USB standard cable.
- Maximum cable length: 5 m.

## 5.3.8

## CAN

The CAN interface is electrically isolated.

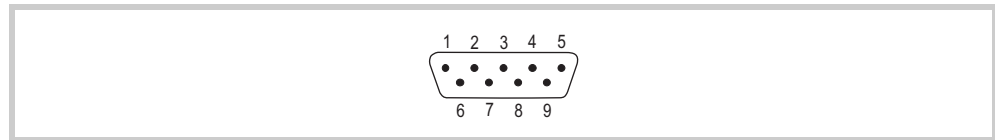

Fig. 20 CAN interface (9-pin, D-Sub, male, UNC)

Pin	Signal	Assignment
1	-	nc
2	CAN-L	Bus line (dominant low)
3	CAN-GND	CAN Ground
4	-	nc
5	-	nc
6	GND	Optional CAN Ground
7	CAN-H	Bus line (dominant high)
8	-	nc
9	-	nc

Tab. 15 Pin assignment of CAN interface in accordance with CiA



- Pin 3 (CAN-GND) and 6 (GND) are connected internally in the device.
- nc: Pins 1, 4, 5, 8 and 9 must not be connected!
- The CAN bus drivers are fed internally with power.
- No power supply for third-party devices is implemented on the CAN connector.

## Wiring

- Shielded cables must be used.

Cable specifications	
Rated surge impedance	120 $\Omega$
Permissible surge impedance	108 ... 132 $\Omega$
Capacitance per unit length	< 60 pF/m
Core cross-section / max. cable length	$\geq 0.25 \text{ mm}^2 / 100 \text{ m}$
	$\geq 0.34 \text{ mm}^2 / 250 \text{ m}$
	$\geq 0.75 \text{ mm}^2 / 500 \text{ m}$

Tab. 16 Cable specifications

- The maximum baud rate depends on the cable length:

Cable length	Max. baud rate
40 m	1000 Kbit/s
50 m	800 Kbit/s
100 m	500 Kbit/s
250 m	250 Kbit/s
500 m	125 Kbit/s
500 m	100 Kbit/s
1000 m	50 Kbit/s
2500 m	20 Kbit/s
5000 m	10 Kbit/s

Tab. 17 Relationship of cable length / baud rate

- **The use of repeaters is recommended with cables over 1000 m in length. Repeaters can also be used to implement electrical isolation. Refer to the documentation of the repeater manufacturer for further information.**
  - **Observe the recommendations of the CiA (CAN in Automation).**
  - **When preparing the cables, ensure that there is a low-resistance connection between the cable shield and the connector casing (→ Chapter 5.3.2, 29).**

### CAN bus topology

- A bus segment can connect up to 32 bus stations.
- Several bus segments can be linked via repeaters (bidirectional amplifiers). Refer to the documentation of the repeater manufacturer for further information.
- A bus segment must be provided with cable termination ( $120 \Omega$ ) at both ends. These terminations must be connected in the connector, directly between pin 2 and 7.
- **The bus segment must be terminated at both ends.**
  - **No more than two terminations must be provided on each bus segment.**
  - **Transmission faults can occur if operation is carried out without the correct termination.**

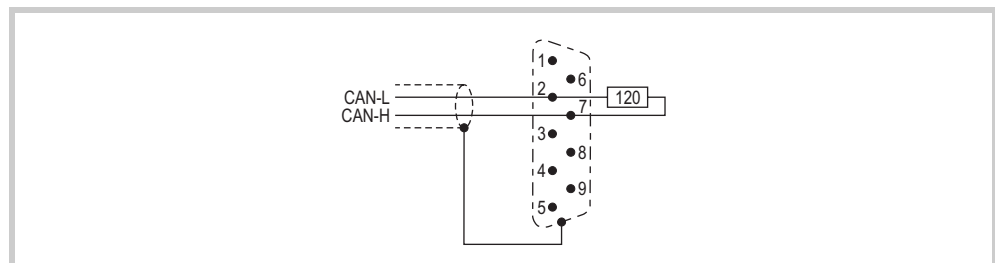

Fig. 21 Termination

## 5.4

## Mounting

## CAUTION

**Operational malfunctions**

Use of unsuitable or improperly prepared cables, as well as incorrect wiring will mean that neither the values stated in the technical data nor the electromagnetic compatibility (EMC) can be ensured.

- ▶ Only use cables prepared by specialists.
- ▶ The cables used must be prepared according to the interface description in these Operating Instructions.
- ▶ The wiring instructions for the relevant interface must be observed when wiring the device.
- ▶ Any generally applicable regulations and standards must be fulfilled.

## CAUTION

**Device condensation**

If the device is or was exposed to climatic changes (temperature fluctuation, air humidity) moisture can form on or in the device (device condensation). In this case, there is a risk of short-circuit.

- ▶ The device must **not** be switched on when device condensation is present.
- ▶ If condensation is present on the device, or if it was exposed to temperature fluctuations, it must be allowed to adjust to room temperature (do not expose the device to the direct heat of heating devices) prior to commissioning.

- 1 Check the device for damage in transit.



**The device must only be installed and commissioned in perfect technical condition and in compliance with these Operating Instructions.**

- 2 If necessary, fit the required communication module in the device. See Chapter 5.4.1 Fitting the communication module in the device, 38.
- 3 Mount the device in the control cabinet, control panel or the control desk:
  - Devices with standard front, see Chapter 5.4.2, 40.
  - Devices with 4-hole front, see Chapter 5.4.3, 43.
  - Devices with stainless steel front, mounting in accordance with:
    - IP65, see Chapter 5.4.4, 45.
    - IP69K (necessary for cleaning with high-pressure cleaners), see Chapter 5.4.5, 48.
- 4 Connect the device as required.
  - Follow the instructions on wiring the relevant interface. See Chapter 5.3 Cable preparation, 27.



**The device is not provided with an On/Off switch. If the power supply is not provided with a switch, the device will start up (boot) as soon as it is connected to the power supply.**

## 5.4.1

## Fitting the communication module in the device

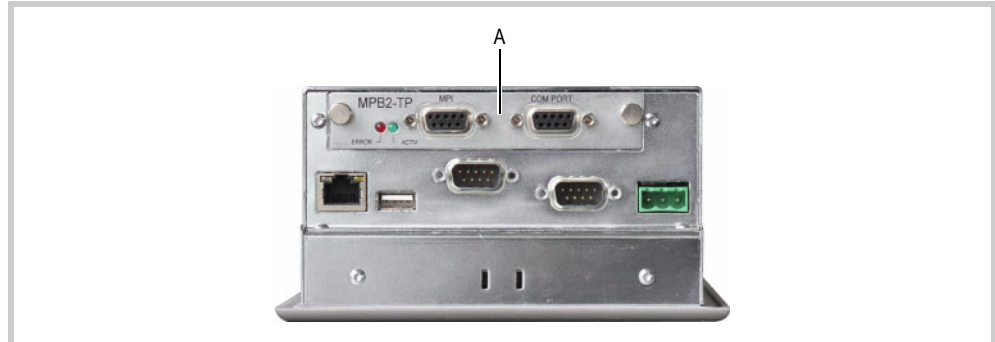

Fig. 22 Slot fitted with a communication module (A)

The device is provided with a slot for a communication module. Optional communication modules enable the device to be connected to automation devices (PLC, drive controls etc.) or to fieldbus systems.



**Only communication modules approved by the manufacturer can be fitted. Please contact your supplier.**

**CAUTION****Live parts in the device**

Damage or destruction of components due to handling when the device is open.

- ▶ Before opening the device:
  - De-energize the device.
  - Remove the power supply connector from the device.
- ▶ Ensure that the device is not energized whilst it is open.
- ▶ Fit a communication module in the device slot or fit the slot cover on the slot before switching on the device.

**CAUTION****Electrostatic discharge**

Electrostatic discharge may damage or destroy electronic components.

- ▶ Avoid contact with components (such as connector pins) that are susceptible to electrostatic discharge.
- ▶ Discharge (by touching a grounded metal object) any static charge accumulated in your body before touching the device.

Procedure:

- 1 Configure the communication module as stated in the relevant module description.
- 2 Loosen the knurled screws on the slot cover.
- 3 Remove the slot cover.
- 4 Fit the communication module in the slot.
- 5 Fasten the communication module with the two knurled screws.

Refer to the relevant module description for information on protocol, configuration, cable lengths etc. of the communication module to be used.

## 5.4.2

## Mounting a device with standard front

 **An additional set of retaining brackets is required for mounting in accordance with IP65 and for use in potentially explosive atmospheres. Please contact your supplier.**

- 1 Select the mounting position of the device as described in Chapter 5.2.1 Requirements for the mounting position,  26.
- 2 Prepare a mounting cutout for the device at the selected position:
  - Mounting cutout:
    - 5.7" devices: 198 × 142 mm (±1 mm)
    - 8.4" devices: 261 × 194 mm (±1 mm)
  - Material thickness at the mounting cutout 2...5 mm

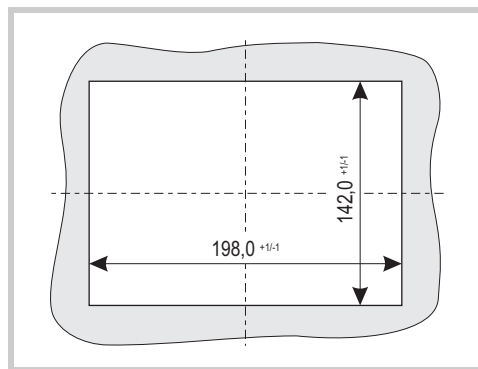

Fig. 23 Mounting cutout for 5.7" devices

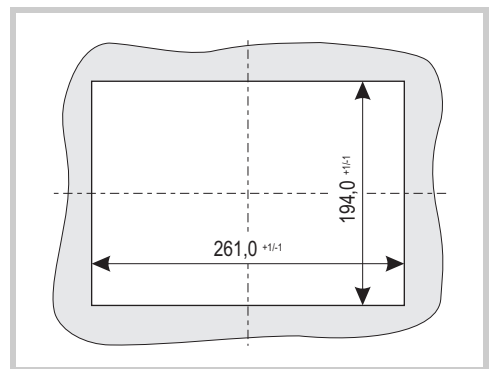



Fig. 24 Mounting cutout for 8.4" devices

- 3 Insert the sealing strip supplied in the groove (A) on the rear of the device front plate and cut it so that the joint is tight.
  - Groove for sealing strip, see Fig. 25,  41.

**CAUTION****Poor sealing**

Poor sealing resulting from the twisting of the sealing strip or due to a gap between the ends of the sealing strip.

- ▶ The join of the sealing strip must be positioned on the bottom of the device.
- ▶ Do **not** twist the sealing strip when it is inserted.
- ▶ Cut the sealing strip to a suitable length so that the join is tight.

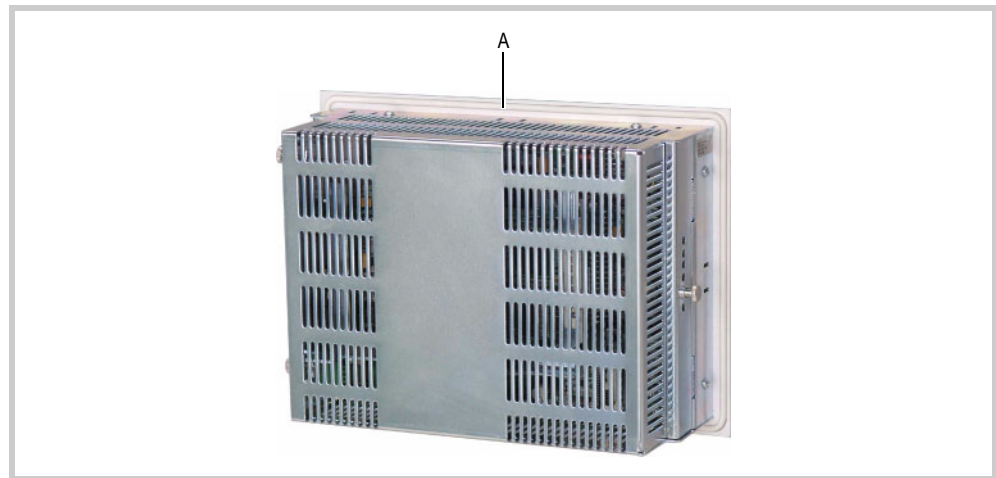

Fig. 25 Groove for sealing strip (A)

- 4 Fit the device from the front into the mounting cutout.
- 5 Clip on the retaining brackets in the recesses provided for them on the device as shown below and fix the device by tightening the threaded pins.

#### CAUTION



#### Mechanical damage to the device

Tightening the threaded pins too tightly may damage the device.

- ▶ Tighten threaded pins with a max. tightening torque of 0.2 Nm.



The positions of the retaining brackets depend on the mounting requirements.

- Standard mounting:
  - Top and bottom of the device:  
Fit one retaining bracket each at the left and right fixing position

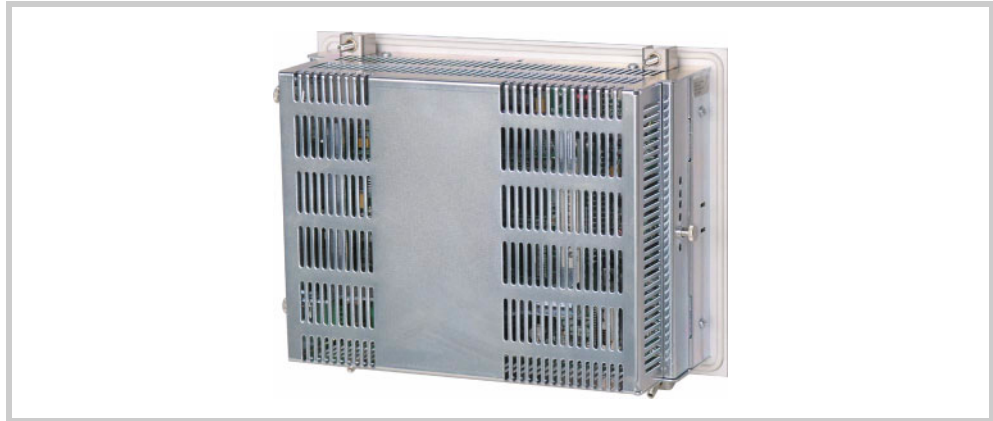

Fig. 26 Devices with four retaining brackets (do not meet IP65 requirements)

- Devices which must be mounted in accordance with IP65 or used in potentially explosive atmospheres:
  - Top and bottom of the device:  
One retaining bracket at each of the fixing positions (left, right and in the center)
  - Left and right on the device:  
One retaining bracket each at the central fixing position

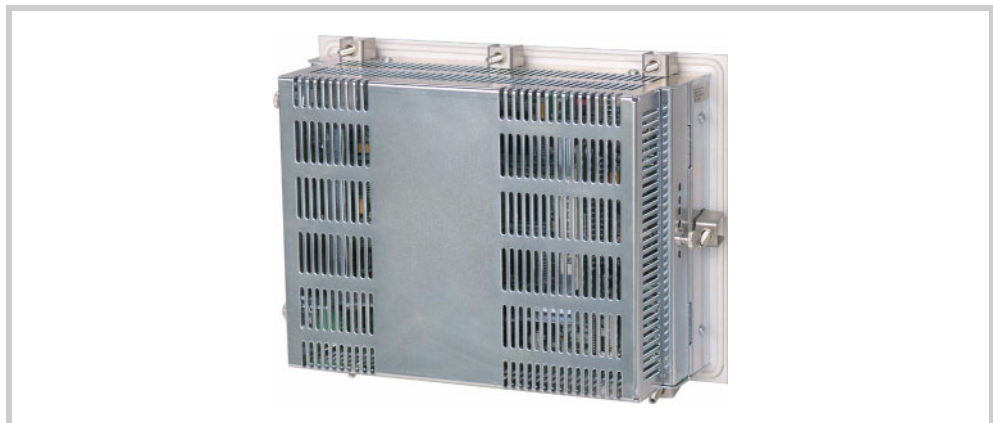



Fig. 27 Devices with eight retaining brackets (meet IP65 requirements)

## 5.4.3

## Mounting a device with 4-hole front

 An optional counter frame is required for mounting in accordance with IP65 and for use in potentially explosive atmospheres. Please contact your supplier.

- 1 Select the mounting position of the device as described in Chapter 5.2.1 Requirements for the mounting position,  26.
- 2 Prepare a mounting cutout for the device at the selected position:
  - Mounting cutout  $198 \times 142$  mm ( $\pm 1$  mm)
  - Four through holes  $\varnothing 4.5$  mm, 180 mm ( $\pm 0.2$  mm) and 157 mm ( $\pm 0.2$  mm) apart
  - Material thickness at the mounting cutout 2 ... 20 mm

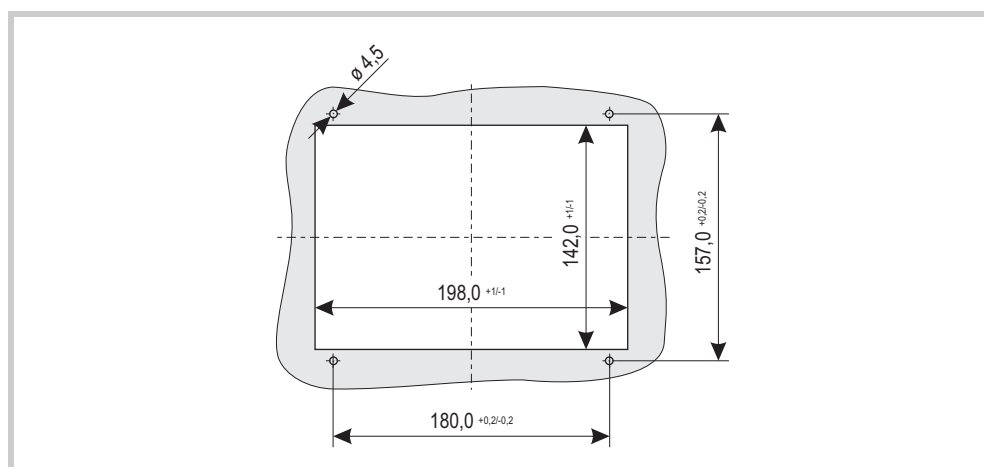

Fig. 28 Mounting cutout for 5.7" devices

- 3 Mounting the front seal:



Fig. 29 Front seal fitted

A Front seal

B Countersunk screw

- 3.1 Fit the countersunk screws in the corresponding holes of the device front plate.
- 3.2 Place the device face down with the countersunk screws.
- 3.3 Pull off the protective foil from the supplied front seal.

- 3.4 Fit the front seal with the adhesive side face down onto the rear of the front plate and press it down.
- 4 Fit the device from the front into the mounting cutout.

**CAUTION****Poor sealing**

Poor sealing resulting from inaccurately positioned front seal.

- ▶ Ensure that the front seal is flat and fitted evenly between the front plate of the device and the mounting surface.

- 5 Fasten the device so that the front seal is correctly seated between the front plate of the device and the mounting surface at the mounting cutout:
  - Use the supplied countersunk screws and nuts (not supplied) if:
    - Mounting to IP65 is **not** required, and
    - The device is **not** used in a potentially explosive atmosphere.
  - Use the supplied countersunk screws and optional counter frame if:
    - Mounting is required to comply with IP65, or
    - The device is used in a potentially explosive atmosphere.



Fig. 30 Counter frame (for mounting to IP65)

## 5.4.4

**Mounting a device with stainless steel front (standard mounting, mounting to IP65)**

- 1 Select the mounting position of the device as described in Chapter 5.2.1 Requirements for the mounting position, 26.
- 2 Prepare a mounting cutout for the device at the selected position:
  - Mounting cutout  $198 \times 142$  mm ( $\pm 1$  mm)
  - Material thickness at the mounting cutout 2...5 mm

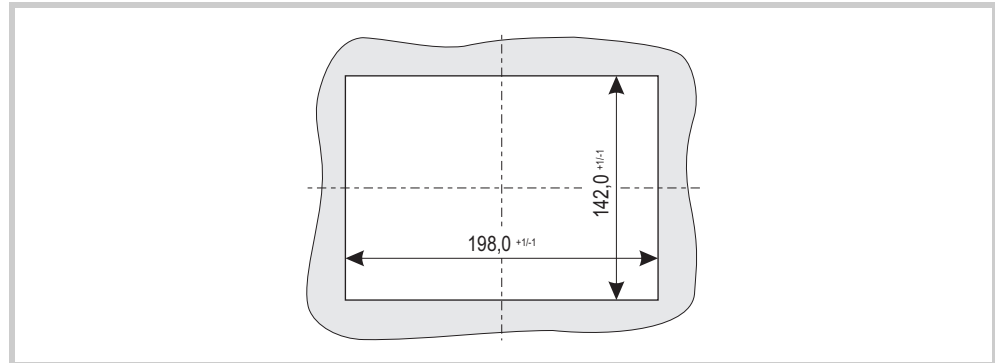

Fig. 31 Mounting cutout for 5.7" devices

- 3 Fit the supplied seal:

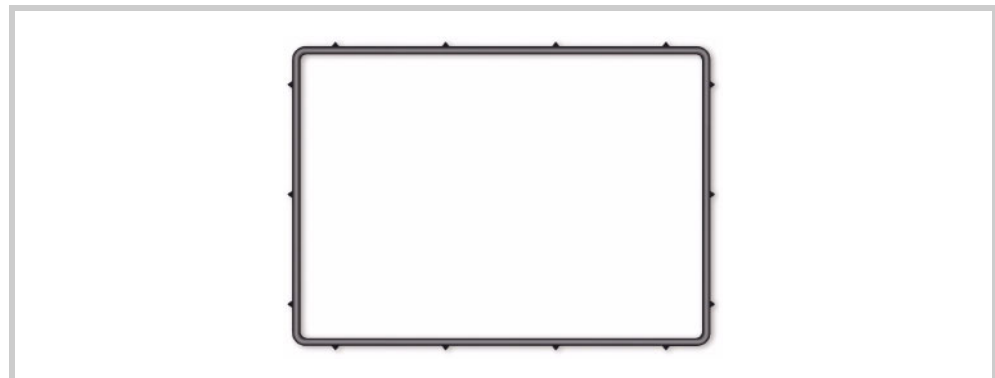

Fig. 32 Seal

**CAUTION****Poor sealing**

Poor sealing resulting from the twisting of the seal or due to protruding securing tabs.

- ▶ Insert the seal correctly.

- 3.1 Fit the seal in the groove on the rear of the device front plate.
- 3.2 Use a small screwdriver to push the securing tabs of the seal into the groove.
  - The securing tabs must not protrude over the edge of the groove.
  - The securing tabs must not point to the bottom of the groove.



Fig. 33 Seal fitted (detail shows optimum position of a securing tab (A))

- 4 Fit the device carefully from the front into the mounting cutout.
- 5 Clip on the retaining brackets in the recesses provided for them on the device as shown below and fix the device by tightening the threaded pins.

#### CAUTION



#### Mechanical damage to the device

Tightening the threaded pins too tightly may damage the device.

- ▶ Tighten threaded pins with a tightening torque of 0.25 ... 0.3 Nm.



The positions of the retaining brackets depend on the mounting requirements.

- Standard mounting:
  - Top and bottom of the device:  
Fit one retaining bracket each at the left and right fixing position



Fig. 34 Devices with four retaining brackets (do not meet IP65 requirements)

- Devices which must be mounted in accordance with IP65 or used in potentially explosive atmospheres:
  - Top and bottom of the device:  
One retaining bracket at each of the fixing positions (left, right and in the center)
  - Left and right on the device:  
One retaining bracket each at the central fixing position

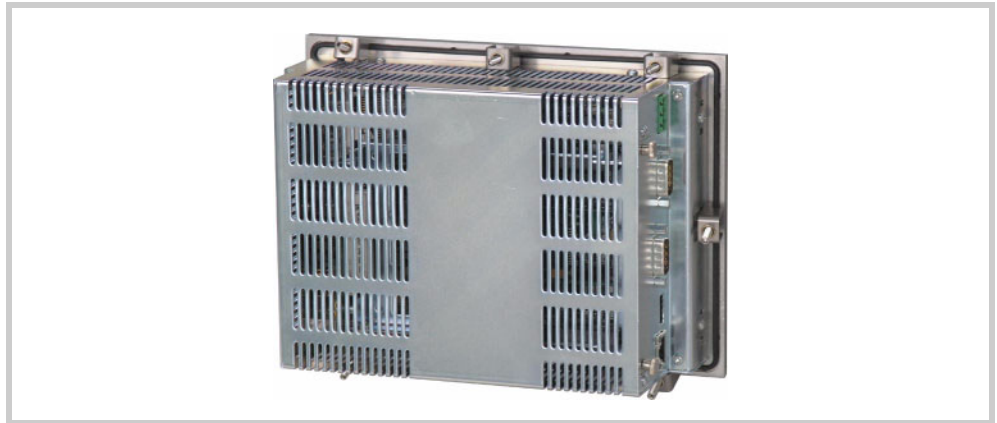

Fig. 35 Devices with eight retaining brackets (meet IP65 requirements)

## 5.4.5

**Mounting a device with stainless steel front (mounting to IP69K)**

- 1 Select the mounting position of the device as described in Chapter 5.2.1 Requirements for the mounting position, 26.
- 2 Prepare a mounting cutout for the device at the selected position:
  - Mounting cutout  $198 \times 142$  mm ( $\pm 1$  mm)
  - Material thickness at the mounting cutout 6...9 mm
  - Recess for front plate  $212.5$  mm ( $\pm 0.3$  mm)  $\times$   $156.5$  mm ( $\pm 0.3$  mm)  $\times$  4 mm
  - Properties of the mounting surfaces:
    - Flatness  $\leq 0.1$  mm  
(this requirement must also be fulfilled when the device is mounted!)
    - Surface roughness  $R_z \leq 6.3$  (corresponds to N5)



The device can also be mounted in a 2...5 mm thick mounting plate. In this case, only the mounting cutout is prepared. After mounting suitable measures must be taken to achieve the required sealing in accordance with IP69K.

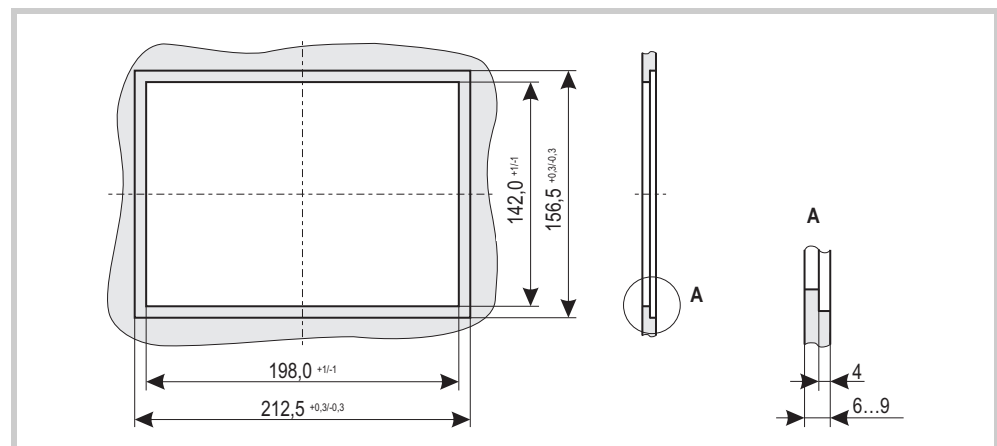

Fig. 36 Mounting cutout for 5.7" devices

- 3 Fit the supplied seal:

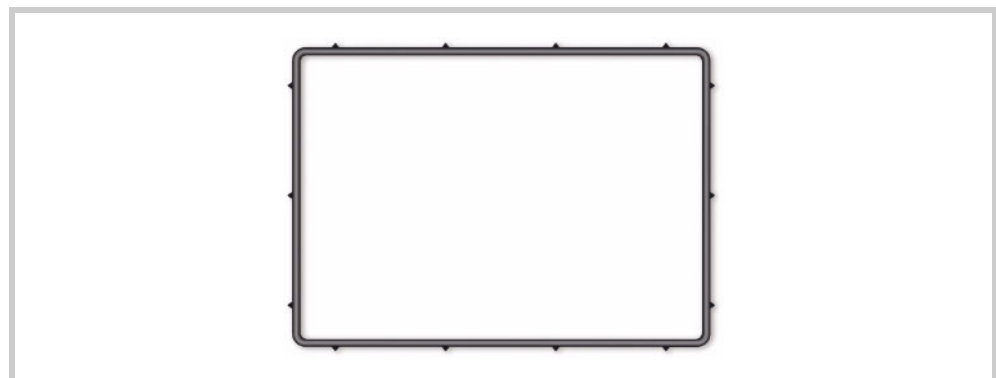

Fig. 37 Seal

**CAUTION****Poor sealing**

Poor sealing resulting from the twisting of the seal or due to protruding securing tabs.

▶ Insert the seal correctly.

- 3.1 Fit the seal in the groove on the rear of the device front plate.
- 3.2 Use a small screwdriver to push the securing tabs of the seal into the groove.
  - The securing tabs must not protrude over the edge of the groove.
  - The securing tabs must not point to the bottom of the groove.

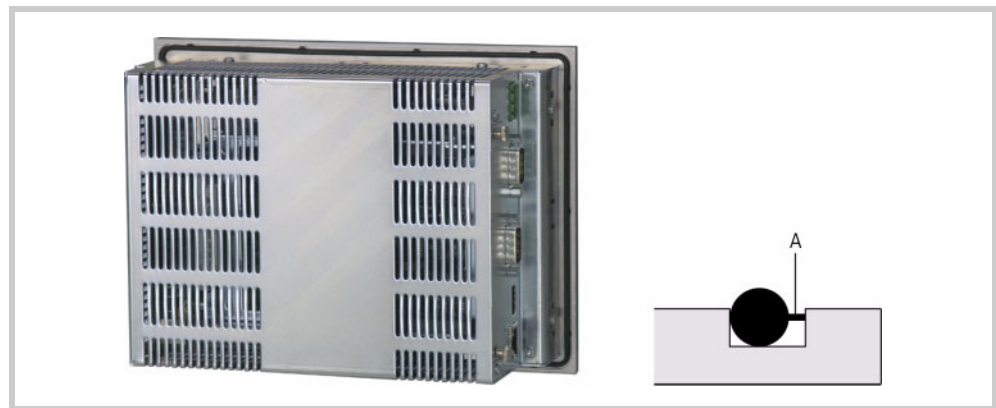

Fig. 38 Seal fitted (detail shows optimum position of a securing tab (A))

- 4 Fit the device carefully from the front into the mounting cutout.
- 5 Clip on the retaining brackets in the recesses provided for them on the device as shown below and fix the device by tightening the threaded pins.

**CAUTION****Mechanical damage to the device**

Tightening the threaded pins too tightly may damage the device.

▶ Tighten threaded pins with a tightening torque of 0.25 ... 0.3 Nm.

- Top and bottom of the device:  
One retaining bracket at each of the fixing positions (left, right and in the center)
- Left and right on the device:  
One retaining bracket each at the central fixing position

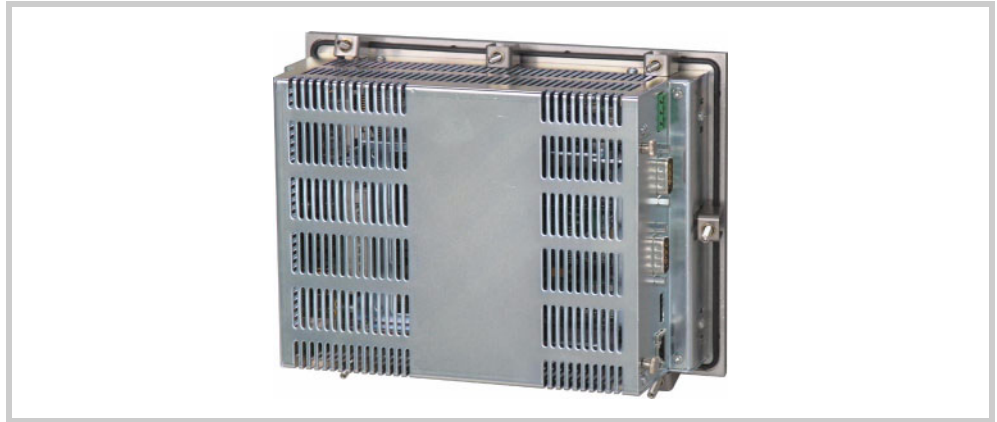

Fig. 39 Devices with eight retaining brackets

- 6 If the device front plate is **not** flush mounted, fit a suitable protection in order to achieve the required sealing in accordance with IP69K.
- The following figure shows the device front plate mounted in the mounting plate. IP69K is ensured.

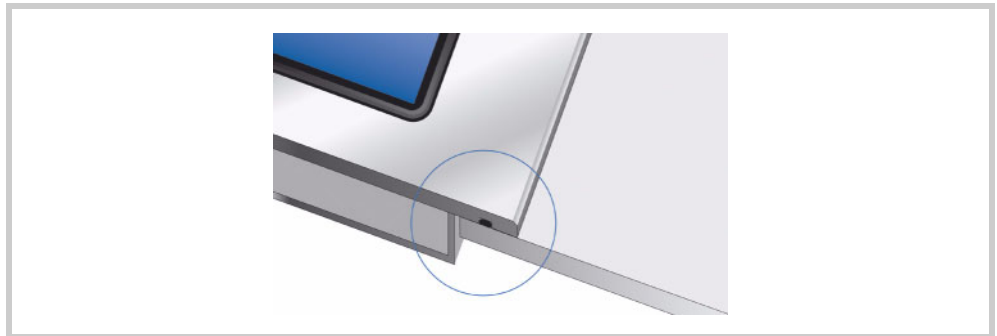

Fig. 40 Device front plate is flush mounted

- In the following figure the device front plate is **not** mounted in the mounting plate. IP69K is **not** ensured. A suitable protection must be fitted.

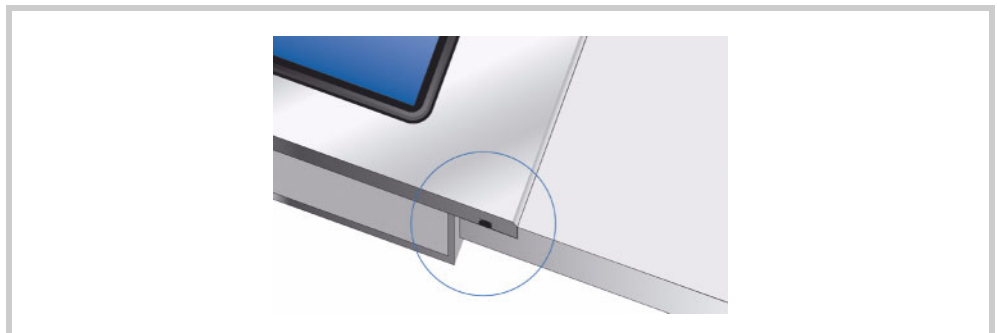



Fig. 41 Device front plate is **not** flush mounted

## 6. Operation

### 6.1 Safety regulations

 Read the Chapter 3. Safety regulations, 15, before working with the device. These contain important information for your personal safety.

#### CAUTION



##### Sensitive resistive touch surface

Damage to the resistive touch due to the use of pointed or sharp objects.

- ▶ Only activate the resistive touch with your finger or a touch pen.
- ▶ When wearing gloves, ensure that these are clean. They must not be covered with abrasive dust or sharp particles.

#### CAUTION



##### Device condensation

If the device is or was exposed to climatic changes (temperature fluctuation, air humidity) moisture can form on or in the device (device condensation). In this case, there is a risk of short-circuit.

- ▶ The device must **not** be switched on when device condensation is present.
- ▶ If condensation is present on the device, or if it was exposed to temperature fluctuations, it must be allowed to adjust to room temperature (do not expose the device to the direct heat of heating devices) prior to commissioning.

#### 6.1.1 Qualification of personnel

The device must only be operated by operating personnel instructed for the application concerned.

## 6.2

## Starting the device

- 1 Insert the CF card with the operating system:

**CAUTION****Data loss**

During a write operation, the CF card may lose data or may be destroyed if it is removed or if there is a power failure.

- ▶ Always secure CF cards with the CF slot cover.
- ▶ Avoid write operations to CF cards. Reasons:
  - The number of write cycles possible on CF cards is limited.
  - A power failure during write operations will most likely lead to loss of data.
- ▶ Only remove the CF card when the device is in a de-energized state.
- ▶ Before switching off, ensure that no software write operations to the CF card are in progress («CF ACT» LED must not be lit).

- 1.1 Remove the CF slot cover (A).



Fig. 42 Service side of the device (CF slot cover fitted)

- 1.2 Insert the CF card into CF slot (B).





**Do not apply any force (CF cards are protected against reverse insertion).**



Fig. 43 Service side of the device (CF slot cover removed)

- 1.3 Fit the CF slot cover (A).
- 2 Energize the device.
  - The device will boot.

- 3 If the device does not boot up and/or if an error message appears while starting (booting) the device, see Chapter 7.4 Troubleshooting and fault rectification,  60.
  - 4 Complete the following steps after initial commissioning (→ Document «M000174»):
    - 4.1 Adjust the system settings of the device.
    - 4.2 Install the required application programs.
-  **The lifespan of the backlight can be increased by reducing the brightness (→ Document «M000174»).**

## 6.3

## Switching off the device

## CAUTION

**Data loss**

During a write operation, the CF card may lose data or may be destroyed if it is removed or if there is a power failure.

- ▶ Always secure CF cards with the CF slot cover.
- ▶ Avoid write operations to CF cards. Reasons:
  - The number of write cycles possible on CF cards is limited.
  - A power failure during write operations will most likely lead to loss of data.
- ▶ Only remove the CF card when the device is in a de-energized state.
- ▶ Before switching off, ensure that no software write operations to the CF card are in progress («CF ACT» LED must not be lit).



**Frequent on/off switching of the device, especially at low temperatures, will reduce the lifespan of the cold cathode tubes (CCFL) of the backlight.**

- Avoid frequent on/off switching of the device.
- Reduce the brightness of the backlight instead (→ Document «M000174»).

- 1 De-energize the device.

## 7. Maintenance and service

### 7.1 Safety regulations



Read the Chapter 3. Safety regulations, 15, before working with the device. These contain important information for your personal safety.

#### 7.1.1 Qualification of personnel

The device should only be maintained and serviced by persons with the following qualifications, according to the task required:

- Cleaning:
  - Operating personnel
- Troubleshooting:
  - Persons with the specific knowledge required
- Repairs:
  - See Chapter 7.3.1 Repairs, 59

## 7.2

### Maintenance

Resistive touch devices are maintenance-free. However, the following work may be necessary:

- Cleaning of the resistive touch if contaminated.
- Recalibration of the resistive touch if it does not respond correctly to touch operation.

The infra-red frame on infra-red touch devices must be cleaned regularly (see Chapter 7.2.3 Cleaning the infra-red touch, 57). Otherwise these devices are maintenance-free.

### 7.2.1

#### Cleaning the resistive touch

##### CAUTION



##### Cleaning the device

Damage to the device due to the use of pointed or sharp objects or by liquids.

- ▶ Do not use any pointed or sharp objects (e.g. knife) for cleaning.
- ▶ Do not use any aggressive or abrasive cleaning agent or solvent.
- ▶ Avoid any liquid entering the device (risk of short-circuit).

- 1 Clean the resistive touch carefully with a clean, damp cloth.
  - With stubborn contamination, spray a little cleaning agent onto the damp cloth first of all.

### 7.2.2

#### Recalibrating a resistive touch

The resistive touch is already calibrated when delivered. However, it must be recalibrated if it does not respond correctly to touch operation. Touch calibration, see Document «M000174».

## 7.2.3

## Cleaning the infra-red touch

The infra-red frame must be cleaned regularly.



The infra-red touch needs to be cleaned if the following is indicated:

- On the service side, the «TOUCH ERROR» LED flashes
- On the taskbar of the display, one of the following icons will appear:



: Contaminated touch sensor



: Faulty or severely contaminated touch sensor

- A visualization application will show an appropriate warning.

The infra-red channels may be interrupted if the infra-red frame is severely contaminated. In extreme cases, this may mean that the affected zones of the touch sensor cannot be touch activated.

## CAUTION



## Cleaning the device

Damage to the device due to the use of pointed or sharp objects or by liquids.

- ▶ Do not use any pointed or sharp objects (e.g. knife) for cleaning.
- ▶ Do not use any aggressive or abrasive cleaning agent or solvent.
- ▶ Avoid any liquid entering the device (risk of short-circuit).

- 1 Clean the infra-red frame and the display with a clean, damp cloth.
  - With stubborn contamination, spray a little cleaning agent onto the damp cloth first of all.

## Cleaning with high-pressure cleaners

Devices with a stainless steel front can be cleaned on the front with high-pressure cleaners, provided that:

- the devices are mounted according to Chapter 5.4.5 Mounting a device with stainless steel front (mounting to IP69K), 48 and
- the ambient conditions comply with IP69K.

Permissible cleaning in compliance with the test specifications of IP69K:

Property	Values
Cleaning pressure	Max. 80 bar
Water temperature	Max. 75 °C
Distance of lance to device surface	Min. 15 cm

Tab. 18 Permissible cleaning in compliance with the test specifications of IP69K:



**In practice, the specifications of the high-pressure cleaners have higher tolerances. We therefore urgently recommend that the following information is added to the cleaning instructions for XV400 5.7"/8.4"; MC2 5.7" with stainless steel front.**

Information in cleaning instructions:

Property	Values
Cleaning pressure	Max. 30 bar
Water temperature	Max. 70 °C
Distance of lance to device surface	Min. 30 cm
Cleaning time on the same spot	Max. 5 s.

Tab. 19 Information in cleaning instructions

#### 7.2.4 **Recalibrating the infra-red touch**

Infra-red touch devices do not have to be recalibrated.

#### 7.2.5 **Battery**

The integrated battery cannot be exchanged. Lifespan, see Chapter 9.4 System,  70.

## 7.3 Service

### 7.3.1 Repairs

Repairs must only be carried out by the manufacturer or from a repair center authorized by the manufacturer.



Contact your local dealer or the technical support of the device manufacturer. Contact address, see Section «Manufacturer», 2.

Only the original packaging should be used for transporting the device.

## 7.4

## Troubleshooting and fault rectification

Fault and possible cause	Corrective action
Device does not start (boot).	
Power supply interface does not have any power.	Check the power supply cable.
While the device is starting (booting), the following message appears:	
«No Card in CF slot 0 detected !!!»	
The CF slot 0 does not contain a CF card.	Insert the CF card with the operating system in the CF slot 0.
CF card in CF slot 0 could not be read (faulty).	Replace CF card.
«Search Subdirectory ... not found»	
The CF card in CF slot 0 does not have an OS (operating system).	<ul style="list-style-type: none"> <li>■ If the CF card does not contain an operating system, load one onto a CF card.</li> <li>■ Insert the CF card with the operating system in the CF slot 0.</li> </ul>
«<50> Touch is dirty or defect» (only appears if GALILEO is installed)	
Resistive touch is not correctly calibrated.	<ul style="list-style-type: none"> <li>■ Start (boot) the device.</li> <li>■ Calibrate touch (→ Document «M000174»).</li> </ul>
Infra-red frame of the infra-red touch is contaminated.	Clean the infra-red frame (→ Chapter 7.2.3, 57).
The threaded pins for mounting the device have been tightened too much.	Loosen the threaded pins (observe max. torque, → Chapter 5.4, 37).
Device is faulty.	Send in your device for repair.
Display remains or becomes dark.	
Backlight is switched off.	Check the function in the visualization software.
Backlight is faulty.	Send in your device for repair.
Touch does not react or does not react correctly to touch operation.	
Resistive touch is not correctly calibrated.	<ul style="list-style-type: none"> <li>■ Start (boot) the device.</li> <li>■ Calibrate touch (→ Document «M000174»).</li> </ul>
Infra-red frame of the infra-red touch is contaminated.	Clean the infra-red frame (→ Chapter 7.2.3, 57).

Fault and possible cause	Corrective action
Touch is deactivated.	<ul style="list-style-type: none"> <li>■ Start (boot) the device.</li> <li>■ Activate touch (→ Document «M000174»).</li> </ul>
LED «TOUCH ERROR» permanently lit and/or the icon  appears in the taskbar.	
Incorrect operation of the operating elements on the display.	Remove all objects (also fingers) from the area of the display.
Infra-red frame of the infra-red touch is contaminated.	Clean the infra-red frame (→ Chapter 7.2.3,  57).
The threaded pins for mounting the device have been tightened too much.	Loosen the threaded pins (observe max. torque, → Chapter 5.4,  37).
Device is faulty.	Send in your device for repair.

Tab. 20 Troubleshooting and fault rectification



## 8. Storage, transport and disposal

### 8.1 Safety regulations



Read the Chapter 3. Safety regulations, 15, before installing and commissioning the device. These contain important information for your personal safety.

#### 8.1.1 Qualification of personnel

The device should only be stored, transported and disposed of by persons with the following qualifications, according to the task required.

- Storage:  
Persons without special knowledge
- Transport:  
Persons with a specialist knowledge of transport (in particular how to prevent damage in transit)
- Disposal:  
Persons with a specialist knowledge of proper disposal (also about the proper disposal of harmful substances)

### 8.2 Storage

The device should be stored in the original packaging. The ambient conditions must be fulfilled. See Chapter 9.9 Ambient conditions, 73.

### 8.3 Transport

Damage to the device must be prevented during transport. The device should therefore only be transported in the original packaging.

The ambient conditions must be fulfilled even when the device is transported. See Chapter 9.9 Ambient conditions, 73.

- 1 Check the device on arrival for damage in transit.

## 8.4

## Disposal

**DANGER****Explosive and toxic materials**

Any improper handling causes a risk of explosion due to the lithium battery soldered in the device and a risk of poisoning due to the mercury content of the cold cathode tubes.

- ▶ The device must only be disposed of by persons with the required specialist knowledge.

Devices that are no longer used must be properly disposed of in accordance with the applicable national regulations or returned to the manufacturer or sales office.

## Materials used in the device

Component	Material
Housing	Galvanized sheet steel
Front plate, depending on the device version:	
Devices with standard front	Aluminum, Peraluman 101 anodized
Devices with 4-hole front	Aluminum, Peraluman 101 anodized
Devices with stainless steel front	Stainless steel
Infra-red frame	Polycarbonate (PC)
Infra-red touch protective panel	Glass
Resistive touch back panel	Glass with polyester foil
Cold cathode tubes	Mercury (< 5 mg)
Battery	Lithium
Electronic components	Various

Tab. 21 Materials used in the device

## Materials used in the packaging

Packaging	Material
External packaging	Cardboard
Internal packaging	Closed-cell polyethylene foam, CFC-free
Plastic bag	Polyethylene (PE)

Tab. 22 Materials used in the packaging

## 9. Technical data

### 9.1 Dimensions and weights

#### 9.1.1 5.7" devices with standard or stainless steel front

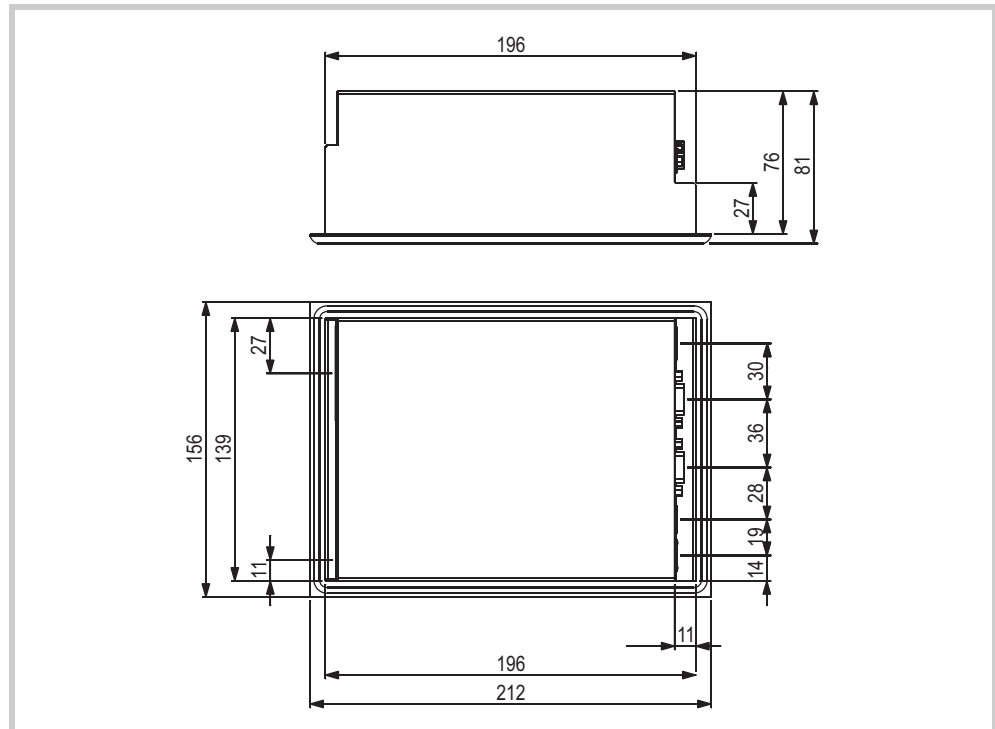

Fig. 44 Mechanical dimensions of the 5.7" devices with standard or stainless steel front

Property	XV400 5.7"; MC2 5.7"
Height	156 mm
Width	212 mm
Depth	81 mm
Thickness of front plate	5 mm
Mounting depth	76 mm
Mounting cutout	198 mm × 142 mm (±1 mm)
Weight	
Devices with standard front	Approx. 1.9 kg
Devices with stainless steel front	Approx. 2.3 kg

Tab. 23 Dimensions and weights of the 5.7" devices with standard or stainless steel front

## 9.1.2

## 5.7" devices with 4-hole front

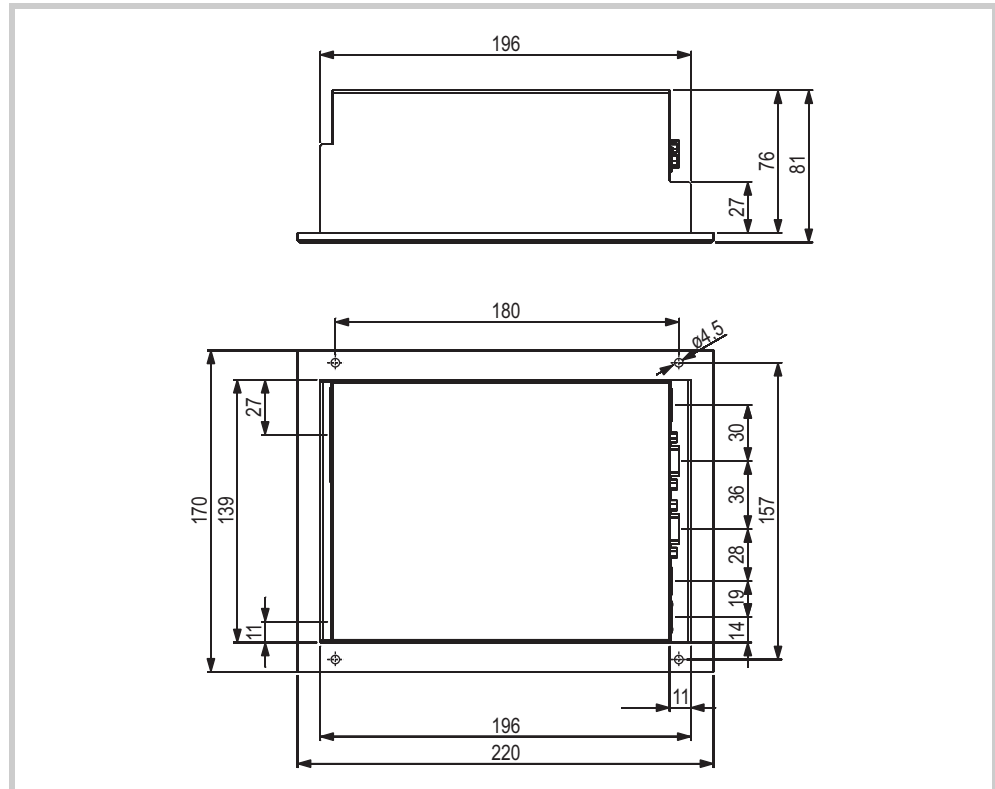

Fig. 45 Mechanical dimensions of the 5.7" devices with 4-hole front

Property	XV400 5.7"; MC2 5.7"
Height	170 mm
Width	220 mm
Depth	81 mm
Thickness of front plate	5 mm
Mounting depth	76 mm
Mounting cutout	198 mm × 142 mm (±1 mm)
Weight	Approx. 1.9 kg

Tab. 24 Dimensions and weights of the 5.7" devices with 4-hole front

## 9.1.3

## 8.4" devices

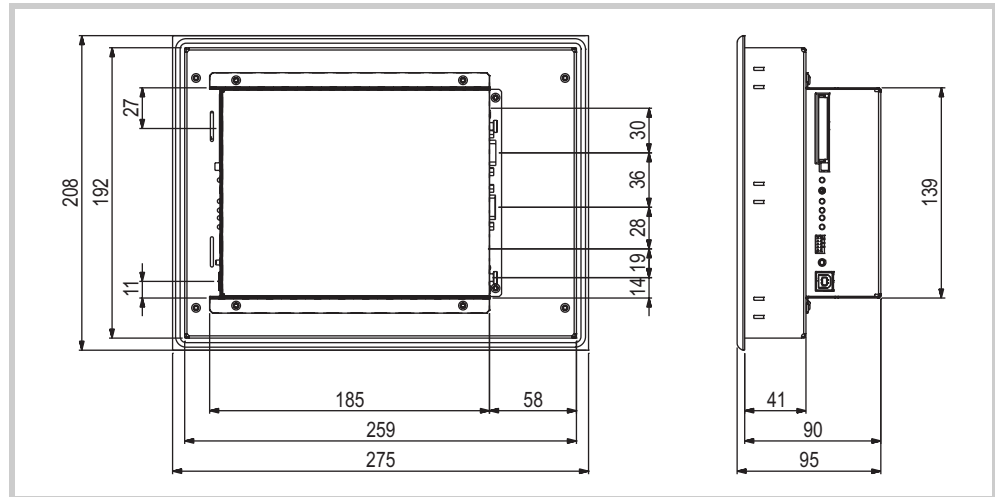

Fig. 46 Mechanical dimensions of the 8.4" devices

Property	XV400 8.4"
Height	208 mm
Width	275 mm
Depth	95 mm
Thickness of front plate	5 mm
Mounting depth	90 mm
Mounting cutout	261 mm × 194 mm (±1 mm)
Weight	Approx. 3.0 kg

Tab. 25 Dimensions and weights of the 8.4" devices

## 9.2 Display

### 9.2.1 5.7" devices XV-432-57; MC2-432-57 and XV-442-57; MC2-442-57

Property	XV-432-57; MC2-432-57 and XV-442-57; MC2-442-57
Type	CSTN-LCD (color)
Resolution (W × H)	QVGA (320 × 240 pixels)
Visible display area	115 mm × 86 mm (5.7" screen diagonal)
Color resolution	256 colors
Contrast ratio	Normally 35:1
Brightness	Normally 150 cd/m <sup>2</sup>
Backlight	
Technology	1× CCFL, dimmable via software
Lifespan	Normally 50 000 h
Resistive touch back panel	Touch sensor (absolutely flat, seamless)
Infra-red touch protective panel	Non-reflective safety glass <sup>1)</sup>

Tab. 26 Display of the 5.7" devices XV-432-57; MC2-432-57 and XV-442-57; MC2-442-57

1) Infra-red touch with standard front and infra-red touch with 4-hole front:  
By the end of 2006: non-reflective glass, from 01.01.2007: non-reflective safety glass

### 9.2.2 5.7" devices XV-450-57 and XV-460-57

Property	XV-450-57 and XV-460-57
Type	TFT-LCD (color)
Resolution (W × H)	QVGA (320 × 240 pixels)
Visible display area	115 mm × 86 mm (5.7" screen diagonal)
Color resolution	Adjustable: 65536 or 256 colors
Contrast ratio	Normally 400:1
Brightness	Normally 350 cd/m <sup>2</sup>
Backlight	
Technology	LED, dimmable via software
Lifespan	Normally 40 000 h
Resistive touch back panel	Touch sensor (absolutely flat, seamless)
Infra-red touch protective panel	Non-reflective safety glass

Tab. 27 Display of the 5.7" devices XV-450-57 and XV-460-57

## 9.2.3

## 8.4" devices

Property	XV400 8.4"
Type	TFT-LCD (color)
Resolution (W × H)	VGA (640 × 480 pixels)
Visible display area	170 mm × 128 mm (8.4" screen diagonal)
Color resolution	Adjustable: 65536 or 256 colors
Contrast ratio	Normally 400:1
Brightness	Normally 350 cd/m <sup>2</sup>
Backlight	
Technology	2× CCFL, dimmable via software
Lifespan	Normally 50 000 h
Infra-red touch protective panel	Non-reflective safety glass

Tab. 28 Display of the 8.4" device

## 9.3

## Touch sensor

## 9.3.1

## Devices with resistive touch

Property	XV400 5.7"; MC2 5.7"
Type	Resistive touch
Technology	4-wire

Tab. 29 Touch sensor of the devices with resistive touch

## 9.3.2

## Devices with infra-red touch

Property	XV400 5.7"/8.4"; MC2 5.7"
Type	Infra-red touch
Resolution	
5.7" devices	47 × 31 logic channels
8.4" devices	63 × 47 logic channels

Tab. 30 Touch sensor of the devices with infra-red touch

## 9.4

## System

Property	XV400 5.7"/8.4"; MC2 5.7"
Processor	RISC, 32-bit, 400 MHz
Internal memory	
DRAM	64 MByte
FLASH	Approx. 1.5 MByte available
SRAM	Approx. 32 KByte available
External memory	
CF slot	CompactFlash Card Type I/II for operating system, programs and data
Real-time clock (battery backup)	
Battery type	CR2032 (190 mA/h), maintenance-free (soldered)
Backup time in de-energized state	Normally 10 years

Tab. 31 System

## 9.5

## Interfaces

Property	XV400 5.7"/8.4"; MC2 5.7"
Ethernet	100Base-TX / 10Base-T
System Port	RS232, not electrically isolated
USB Host	USB 2.0 (1.5 / 12 Mbit/s), not electrically isolated
USB Device	USB 1.1, not electrically isolated
CAN	CAN, electrically isolated
Power supply	→ Chapter 9.5.1, 71
DIAG	Only for service tasks

Tab. 32 Interfaces

## 9.5.1

## Power supply

Property	XV400 5.7"/8.4"; MC2 5.7"
Rated voltage	24 VDC SELV (safety extra low voltage)
Permissible voltage	<ul style="list-style-type: none"> <li>■ RMS value: 20.4...28.8 VDC (rated voltage +20 % / -15 %)</li> <li>■ Absolute with ripple: 19.2...30.0 VDC</li> <li>■ 35 VDC for a period &lt; 100 ms</li> </ul>
Voltage dips	<ul style="list-style-type: none"> <li>■ 20 ms from rated voltage (24 VDC)</li> <li>■ 2 ms from undervoltage (20.4 VDC)</li> </ul>
Power consumption	
5.7" devices	
Basic device	Max. 17 W (normally 13 W)
Communication module	Max. 4 W
USB stations on USB host	Max. 3 W
Total	Max. 24 W
8.4" devices	
Basic device	Max. 19 W (normally 15 W)
Communication module	Max. 4 W
USB stations on USB host	Max. 3 W
Total	Max. 26 W
Current consumption	
Continuous current	
5.7" devices	Max. 1.0 A (24 VDC)
8.4" devices	Max. 1.1 A (24 VDC)
Starting current inrush	2.5 A <sup>2</sup> s
Protection against reverse polarity	Yes
Fuse protection	Yes (fuse cut-out, not accessible)
Potential isolation	No

Tab. 33 Power supply

## 9.6

## IP protection classes

Property	XV400 5.7"/8.4"; MC2 5.7"
Front, depending on the device version:	
Devices with standard front	IP65: Required accessories for mounting: ■ Additional set of retaining brackets (optional)
Devices with 4-hole front	IP65: Required accessories for mounting: ■ Counter frame (optional)
Devices with stainless steel front	■ IP65 ■ IP69K
Rear	IP20

Tab. 34 Protection classes

## 9.7

## Approvals and declarations

Property	XV400 5.7"/8.4"; MC2 5.7"
EMC	89/336/EC
Explosion protection	II 3D EEx II T70°C IP5x (ATEX 94/9/EC): ■ Zone 22, category 3D: Required accessories for mounting: - For devices with standard front: Additional set of retaining brackets (optional) - For devices with 4-hole front: Counter frame (optional)

Tab. 35 Approvals and declarations

## 9.8

## Applicable standards and regulations

Property	XV400 5.7"/8.4"; MC2 5.7"
EMC (in relation to CE)	
EN 61000-6-2	Immunity for industrial areas
EN 61000-6-3	Emission for residential, commercial and light-industrial environments
EN 61000-6-4	Emission for industrial environments
EN 61131-2	Programmable logic controllers, equipment requirements and tests
Explosion protection (in relation to CE)	
EN 60079-0 (old: EN 50014)	Electrical apparatus for explosive gas atmospheres
EN 61241-1 (old: EN 50281-1-1)	Electrical apparatus for use in the presence of combustible dust
EN 13463	Non-electrical equipment for use in explosion hazardous areas
Safety	
EN 60950 UL 60950	Safety of information technology equipment
Product standards	
EN 50178	Electronic equipment for use in power installations
EN 61131-2	Programmable logic controllers, equipment requirements and tests

Tab. 36 Applicable standards and regulations

## 9.9

## Ambient conditions

Property	XV400 5.7"/8.4"; MC2 5.7"
Temperature:	
Operation	0 ... 50°C
Storage / Transport	-20 ... 60°C
Relative air humidity	10 ... 95%, non-condensing
Vibration	According to IEC68-2-6
Shock	According to IEC68-2-27
Fall test	According to IEC68-2-32

Tab. 37 Ambient conditions

