

Moeller HPL0211-2004/2005

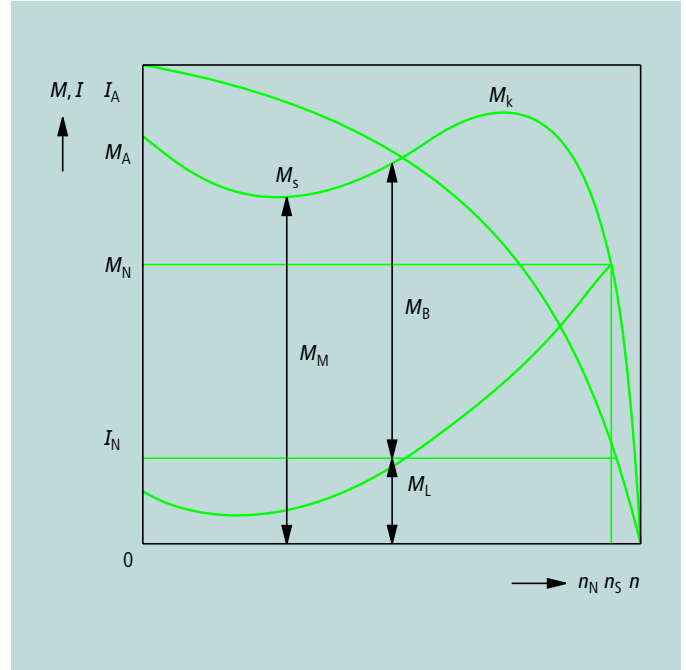

	Page
Basic information	15/2
Product overview	15/13
Conversion of technical units	15/16

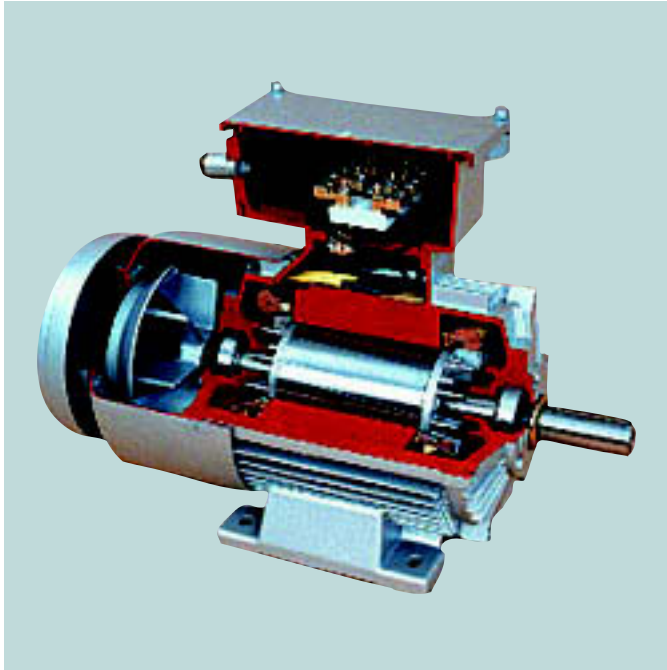



Overview

This technical information should not be regarded as complete. It assumes that the reader is familiar with electrical and electronic systems and the configuration of drives. Its aim is to provide answers to frequently asked questions about drives and related issues, such as: "What do I need?", "What should I take into account?", and "Which standards have a direct impact on engineering?" Local regulations and customer specifications may require standards in excess of those described here. All data and statements are therefore of a general nature and apply specifically to the devices for three-phase drives in this catalogue.

Three-phase drives

Three-phase motors are the most important and most commonly used of all electric motors. They are valued for their robust construction and low cost, even where a high degree of ingress protection is required. Specific types, such as slipping inductors, synchronous motors and pole-changing motors, are not considered here. This overview deals only with the basic principles and issues using the three-phase asynchronous motor as an example.

Specialist Catalogue

Explosion-Proof High- and Low-Voltage Three-Phase Motors, Moeller FK0207+0051-1032GB

The power transmission from the stator to the rotor of a three-phase motor is contactless. The speed is determined by the quotient of the applied frequency and the number of pole-pairs [$n \sim f/p$].

- M_A = Starting torque
- M_S = Pull-up torque
- M_K = Stalling torque
- M_N = Rated torque
- n_N = Rated speed
- n_S = Synchronous speed
- M_M = Motor torque (at the shaft) = $M_B + M_L$
- M_B = Accelerating torque
- M_L = Rated-load torque
- I_A = Starting current on direct power ON
- I_N = Rated current indicated on nameplate

The characteristic curve is determined by the starting torque, the pull-up torque and the stalling torque. The characteristic of each of these variables and the characteristic curve itself depend on the particular motor. In operation at rated frequency, the machine reaches its rated speed (n_N) at the rated-load torque (M_N). The rated values that apply for this operating state are indicated on the motor's ratings plate (nameplate).

230 Δ / 400 Y V		4.0 / 2.3 A	
S1 0,75 kW		cos φ 0.67	
1410 rpm		50 Hz	

Example: Ratings plate

From the figures on the ratings plate, you can derive all of the motor's nominal values → Page 15/16:

$$P_2 = \frac{M \times n}{9550} \quad \eta = \frac{P_2}{P}$$

$$P_1 = U \times I \times \sqrt{3} \times \cos \varphi$$

Note:

In operation, the mains voltage (3 AC 400 V) must be the same as the motor's rated voltage (400 V).
In continuous operation, the full torque of self-ventillating motors is generated only from about 20 Hz (depending on the motor type).

Further reading:

Power Electronics, a Beginner's Guide, Moeller TB 82-005



Moeller HPL0211-2004/2005

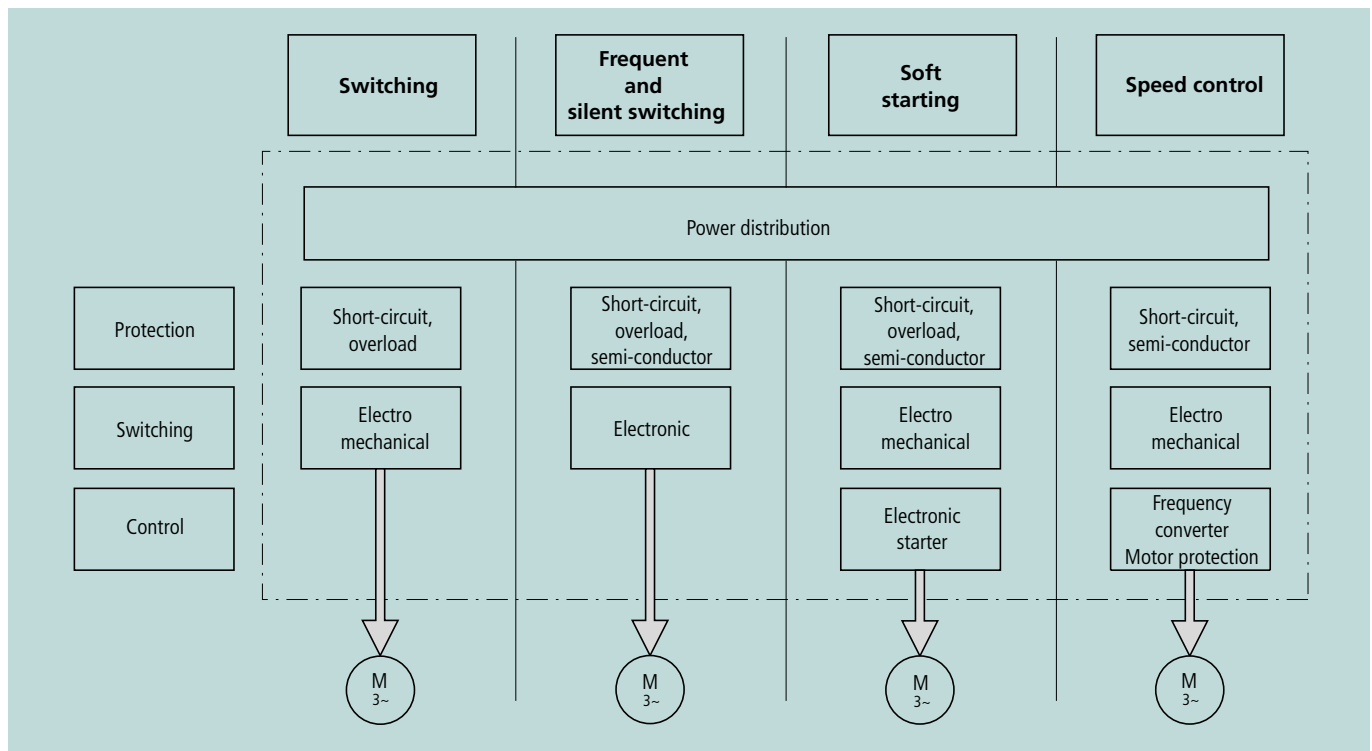

All around the motor

With the invention of the three-phase motor in 1888 by electrical engineer Michail O. Doliwo-Dobrowolsky, and the introduction of AC supply mains in 1892, the practice of using a separate drive unit for each machine became commonplace. Today, this drive concept is the standard for both constant- and variable-speed applications.

With the growing popularity of the three-phase motor, the need arose to find ways of ensuring a satisfactory starting behaviour and reliable motor protection. Moeller has been meeting these needs for over 100 years with components for switching, protecting, and controlling motors. A complete core range of products, covering everything from conventional electromechanical switching devices to state-of-the-art control units, provide effective, tailored solutions for plants and machines.

Different applications make varying demands on electrical drives. A range of products to meet specific requirements is therefore needed. A single, universal solution for all conceivable applications cannot realistically be implemented at an acceptable cost.

The following pages provide an overview of the available electrical starting types of the three-phase motor. The simplified current and torque graphs illustrate the behaviour of each starting solution.



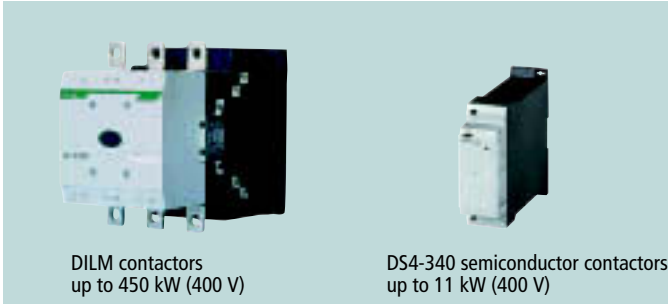

DILM contactors up to 450 kW (400 V)

DS4-340 semiconductor contactors up to 11 kW (400 V)

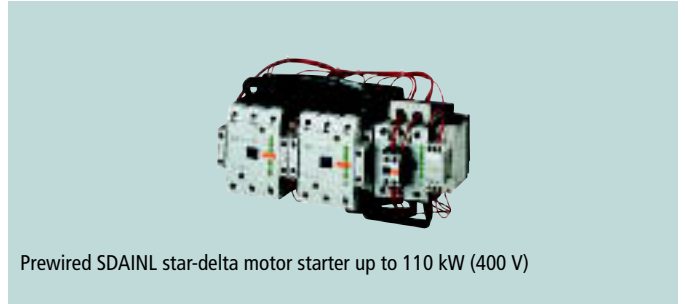

Prewired SDAINL star-delta motor starter up to 110 kW (400 V)

DOL start

In the simplest case, and especially at low rated output (up to about 5.5 kW), the three-phase motor is connected directly to mains voltage. In most applications, the connection is made with an electromechanical contactor. In this control mode, – on the mains with fixed voltage and frequency – the speed of the asynchronous motor is only slightly below the synchronous speed $[n_d \sim f]$. The operating speed $[n]$ deviates from this value due to rotor slippage in relation to the rotating field $[n = n_d \times (1 - s)]$, slippage being $[s = (n_d - n)/n_d]$. On starting ($s = 1$), a high starting current occurs, reaching up to ten times the rated current I_e .

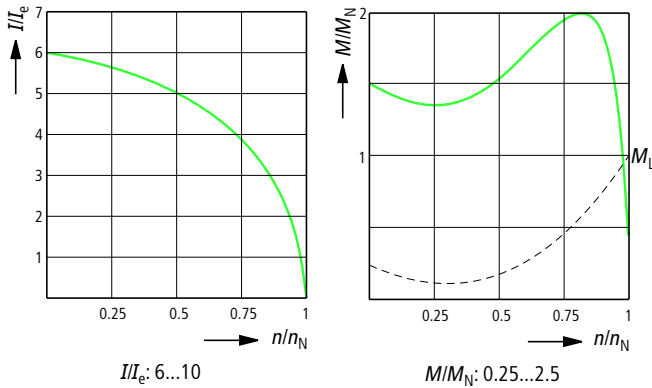

Features of DOL starting

- For low- and medium-power three-phase motors
- Three connection lines (circuit type: star or delta)
- High starting torque
- Very high mechanical load
- High current peaks
- Voltage dips
- Simple switching devices

If frequent and/or silent switching is required, or if unfavourable environmental conditions limit the use of electromechanical switching elements, electronic semiconductor contactors¹⁾ are required here. Examples include building services management (reversing drives for elevator doors; starting heat-exchangers) and critical (explosive) atmospheres (controlling petrol pump or paint processing plant motors). Further applications include non-motor-driven loads, such as heater elements in extruders or ovens and lighting controllers.

Motor start in star-delta arrangement

Most commonly used for starting three-phase motors in the star-delta circuit layout.

Star circuit

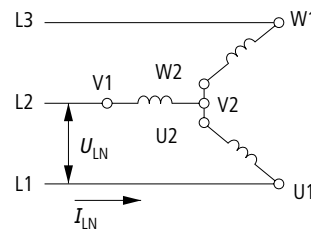

Delta circuit

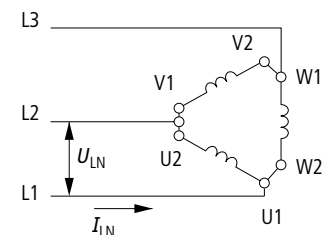

$U_{LN} = \sqrt{3} \times U_W \quad I_{LN} = I_W$

$U_{LN} = U_W \quad I_{LN} = \sqrt{3} \times I_W$

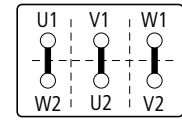
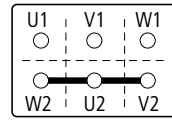

The completely factory prewired SDAINL star-delta combination from Moeller provides convenient motor control. The customer saves on expensive wiring and installation time and reduces the likelihood of faults.

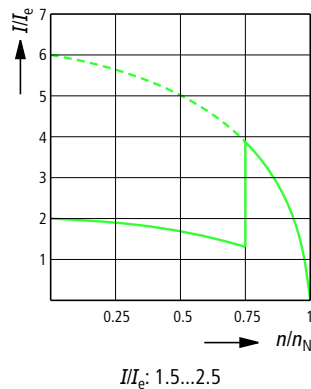

Features of star-delta starting

- For low- to high-power three-phase motors
- Reduced starting current
- Six connection cables
- Reduced starting torque
- Current peak on changeover from star to delta
- Mechanical load on changeover from star to delta

¹⁾ Note: If a semiconductor contactor is used, the semiconductor must be protected by a superfast fuse in addition to short-circuit and overload protection. According to IEC/EN 60947, type "2" coordination requires the use of a superfast semiconductor fuse. For type "1" coordination, – the majority of cases – a superfast semiconductor fuse is not necessary.



Moeller HPL0211-2004/2005

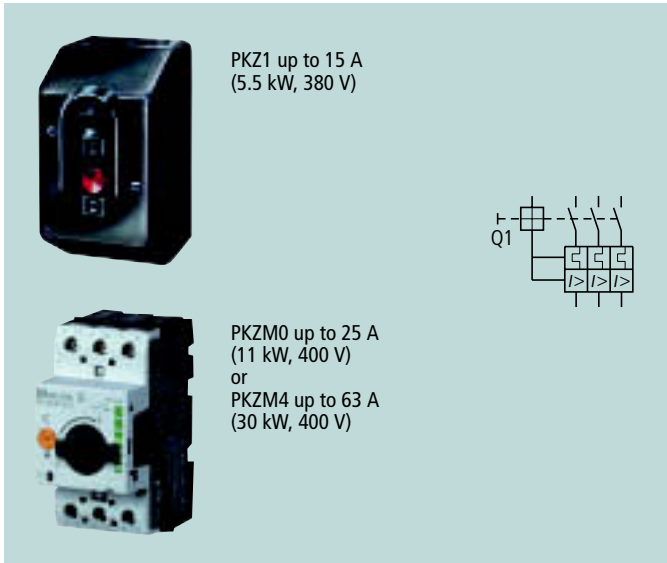

Motor protection

Three-phase motors and cables must be protected against short circuits and overload. As early as 1932, Moeller (then Klöckner-Moeller) introduced its first motor-protective relay, whose type designation – PHKZ – has become synonymous with motor protection.

Since then, Moeller has continued to play a leading role in developing motor protection devices. The latest example is its ZEV motor protective system, consisting of a circuit-breaker with display and only four current sensors that cover the wide current range of 1 to 820 A and are moreover small and easy to fit. These benefits are especially apparent in the ZEV-XSW-820: Based on the Rogowski principle, this unit's volume is a 58th of comparable conventional units. Mounting is easy with Velcro fasteners, the sensor belts being simply laid around the motor cables. In addition to indirect motor current measurement, the tripping unit measures the temperature using thermistors (PTC sensors) that are built into the motor winding as well as providing phase failure, current imbalance and earth-fault protection.

Networked motor starters

Networked motor starters consist of a contactor, motor and line protection, and a communications interface.

The KLAS load feeder system from Moeller is a fully prewired DOL and reversing starter. A ready-to-connect installation device, it can be networked through an AS interface to guarantee success in numerous applications.

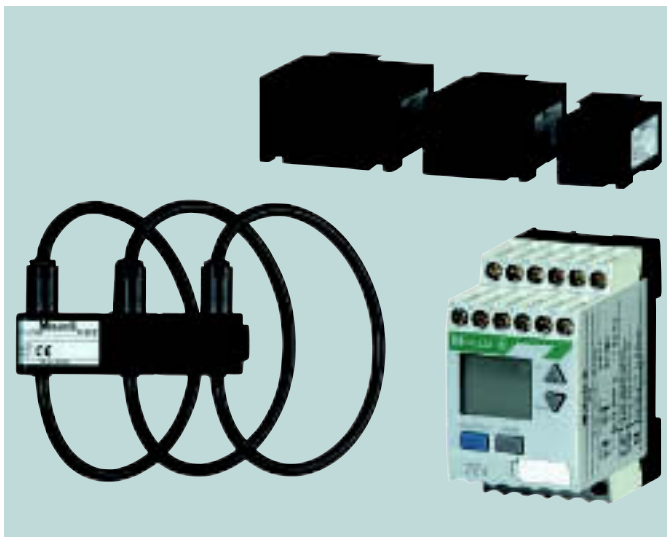

The xStart-XS1 motor starters also fulfill customer requirements for high plant availability with minimal standstill times for maintenance. Here, the motor-protective circuit-breakers (PKZM) and contactors (DILM) are mechanically linked. This unit is connected to the hardwired base unit in the power and control section through plug connectors and can be hot-swapped (plugged in and drawn during operation).

The fieldbus module (DeviceNet, PROFIBUS DP, CANopen) and the XI/ON system's additional inputs/outputs (→ HPL0213-2004/2005 section 06) allow a highly modular arrangement.

The safety version of xStart-XS1 features networked coordination type "1" and "2" according to IEC/EN 60947 with interlocked opposing auxiliary contacts and safety relays for plant and personal protection in the event of faults.

Engineering → Page 16/7



Distributed drive control

The requirements for distributed drive control are met by the Rapid Link system (→ Product Range Catalogue SK 2190-1063).

This system's simple and error-free installation through plug-in connections with IP 65 ingress protection make possible the direct installation of DOL motor starters (RA-MO) and frequency-controlled speed regulators (RA-SP) immediately next to the motor. Standardization of hardware and software saves time and money in engineering, commissioning and servicing.

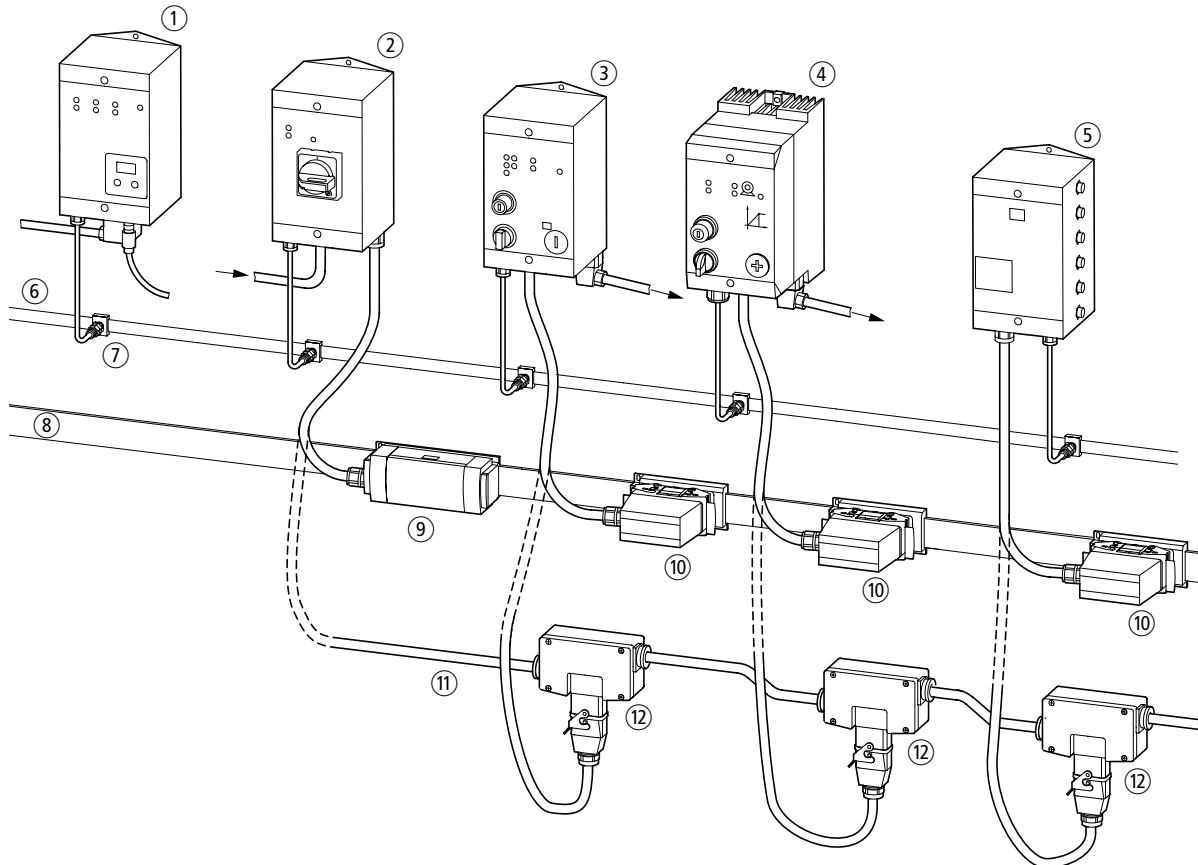
**Function modules:**

- ① Interface control unit
→ Interface to the open field bus
- ② Disconnect control unit
→ Power supply with lockable handle
→ Circuit-breaker for overload and short-circuit protection
- ③ Motor control unit
→ Three-phase electronic motor protection with additional use as direct-on-line starter, expandable DOL starter or reversing starter
- ④ Speed control unit
→ Operation of three-phase asynchronous motors with four fixed speeds, two directions and soft starting
- ⑤ Logic control unit
→ Intelligent slave for autonomous processing of I/O signals

Power and data bus:

- ⑥ AS interface® flat cable
- ⑦ Link for M12 connector cables
- ⑧ Flexible busbar for 400 V ~ and 24 V ---
- ⑨ Power feed for flexible busbar
- ⑩ Plug-in power link for flexible busbar
- ⑪ Round cable for 400 V ~ and 24 V ---
- ⑫ Plug-in link for round cable



Moeller HPL0211-2004/2005



DS4 up to 15 kW

DM4 soft starters up to 900 kW

Soft starters (electronic motor start)

The characteristic curves for DOL and star-delta starting show sudden current and torque changes, which have a number of negative effects, especially at medium and high motor ratings:

- High mechanical machine loads
- Rapid wear
- Increased servicing costs
- High supply costs from the power supply companies (peak current calculation)
- High mains and generator load
- Voltage dips with a negative effect in other consumers

The ideal scenario of a smooth torque build-up and a controlled current reduction in the starting phase is made possible by the electronic soft starter. Providing infinitely variable control of the three-phase motor's supply voltage in the starting phase, it matches the motor to the load behaviour of the driven machine and accelerates it smoothly. Mechanical impacts are avoided, current peaks suppressed and the conventional star-delta function is simply replaced.

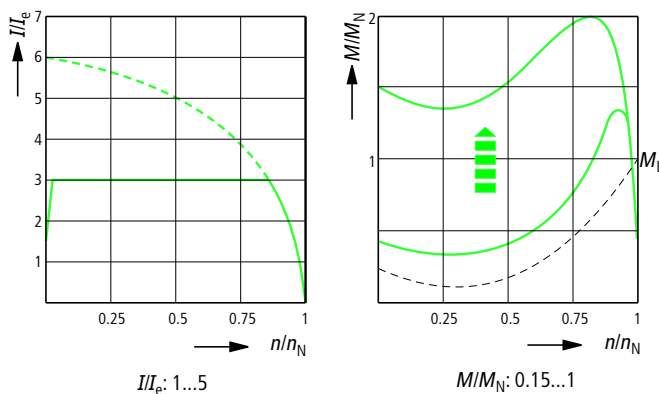

Features of the soft starters

- For low- to high-power three-phase motors
- No current peaks
- Zero maintenance
- Reduced adjustable starting torque

High-grade soft starters, such as those of the DM4 series, can today be adapted to the requirements of specific applications and – beside the typical pump and fan applications – can also be used for controlling transport and conveyor systems, compressors, circular and band saws, agitators and mixers, and even heavy starting of mills and crushing plants.

Ten preprogrammed parameter sets for typical applications can be simply called up with a selector switch.



Additional plant-specific settings can be defined with an optional keypad.

Here, as an example, the three-phase AC power controller mode: In this mode, three-phase resistive and inductive loads – heaters, lighting systems, transformers – can be controlled with the DM4. Both open-loop and – with measured value feedback – closed-loop control are possible.

- Instead of the keypad, intelligent interfaces can also be used:
- RS 232/RS 485 serial interface (configuration with PC software)
 - Suconet K fieldbus module (interface on every Moeller PLC)
 - PROFIBUS DP fieldbus module

The DM4 soft starters provide the most convenient method of implementing soft starting. Because – in addition to phase failure and motor current monitoring – the motor winding temperature is signalled through the built-in thermistor input, the soft starters eliminate the need for additional, external components, such as motor protective relays.

DM4 conforms to the IEC/EN 60947-4-2 standard.

With the soft starter, reducing the voltage results in a reduction of the high starting currents of the three-phase motor, although the torque is also reduced [$M_{\text{startup}} \sim U$] and [$M \sim U^2$]. After starting, the motor reaches its rated speed with all of the solutions described above. For starting motors at rated-load torque and/or for motor operation at a motor speed that is independent of the supply frequency, a frequency inverter is required.



Inline/delta connection

Normally, soft starters are connected in an in-line arrangement. This has the advantage that only three phases need to be connected to the motor in addition to PE. In a delta layout, each of the soft starter's line paths are connected in series with the corresponding motor winding.

Like the star-delta arrangement, this requires the connection of six phases to the motor. The advantage is that the soft starter's rated output has to be only equal to the cube root of the motor current ($0.58 \times I_N$ motor), which has clear cost benefits.

Example: mains voltage 3 AC 400 V, motor 55 kW

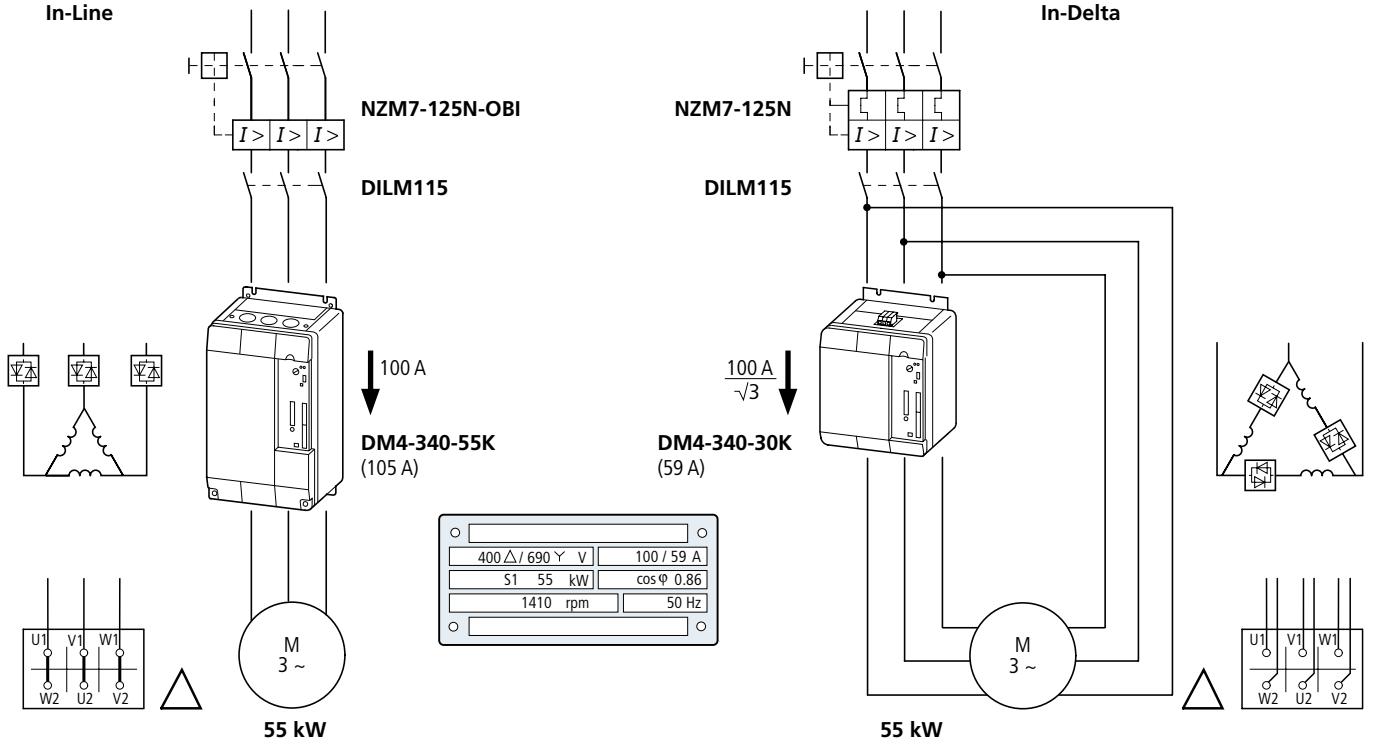

Bypass circuit

In the bypass circuit, a contactor (DILM) is connected in parallel to the soft starter for continuous operation. This reduces the heat dissipation in the control panel and extends the soft starter's lifespan. Example: jolt-free starting of escalators through the soft starter. When the start-up time has expired, protective contacts bridge the thyristors for continuous operation.

The DM4 and DS4 soft starters from Moeller allow automatic actuation of the bypass contactor through the TOR (top-of-ramp) output. The DS4-340-...-MX soft starters feature a built-in bypass contactor.

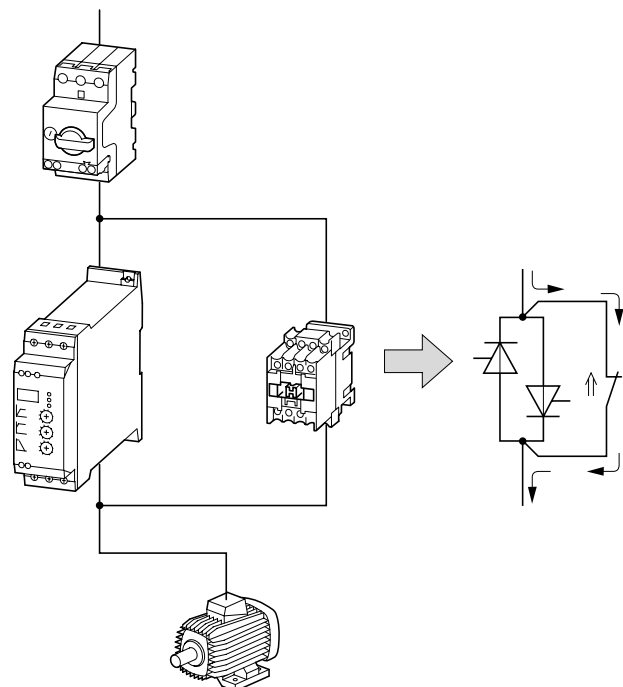

Moeller HPL0211-2004/2005



Frequency inverters

The general growth of automation has – in drive control as elsewhere – resulted in the use of intelligent remote drive modules that can be networked with fieldbus systems. The purely mechanical and stepped methods of speed regulation (such as controller drives and pole-switching of asynchronous motors respectively) are losing their importance, even if they are controlled electronically. Variable-speed drive solutions are seeing increasingly widespread use in all areas of drive control.

Features of the frequency inverters (general)

- For three-phase motors up to 132 kW
- High starting torque
- Constant torque in motor's rated range
- No current peaks
- Infinitely variable speed control through voltage/frequency control (U/f)
- Zero maintenance
- EMC measures (optional: radio interference filter, screened motor cable)

Additional features of sensorless vector control

- Infinitely variable torque control, also at zero speed
- Low torque control time
- Increased concentricity and constancy of speed
- Speed control (options: control module, pulse generator)

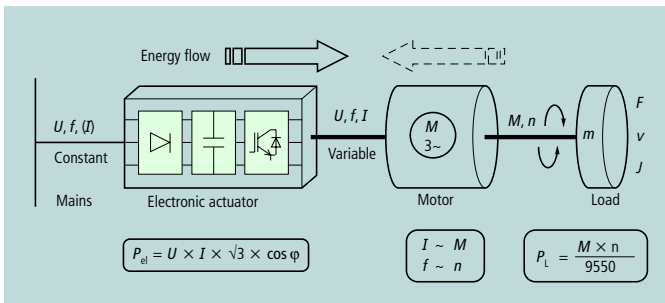

The DF5, DF6, DV5 and DV6 frequency inverters are factory-preset for their assigned motor rating, allowing drives to be started immediately after installation. Individual settings can be made with an optional keypad. Various control modes can be selected and configured in a number of layers, for example frequency control through the U/f characteristic, for simple use with linear and quadratic load characteristics as well as high simultaneous running of multiple motors in parallel operation. Or, with the DV5 and DV6 frequency inverters, field-oriented vector control as frequency or torque control for highly-dynamic drives or high loads. For applications with pressure and flow control, all devices contain a built-in PID controller that can be matched to any system.

Frequency inverters convert constant mains voltage and frequency into a DC voltage, from which they generate a new three-phase supply with variable voltage and frequency for the three-phase motor. From the mains, the frequency inverter draws almost only active power (p.f. ~ 1), the reactive power required for operating the motor being supplied by the internal DC link. This eliminates the need for p.f. correction on the mains side.

A further advantage of the frequency inverters is that they eliminate the need for external components for monitoring and motor protection. On the mains side, only a fuse or circuit-breaker (PHKZ) is needed for line and short-circuit protection. The frequency inverter's inputs and outputs are monitored internally by measurement and control circuits, such as overtemperature, earth fault, short-circuit, motor overload, motor blockage and drive belt monitoring. Temperature measurement in the motor winding can also be incorporated in the frequency inverter's control circuit through a thermistor input.

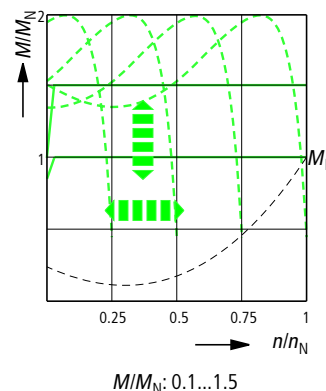
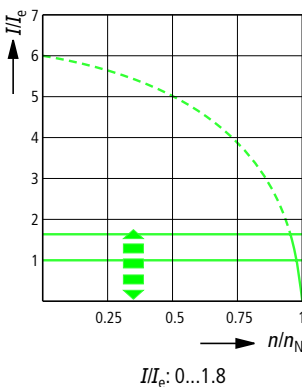

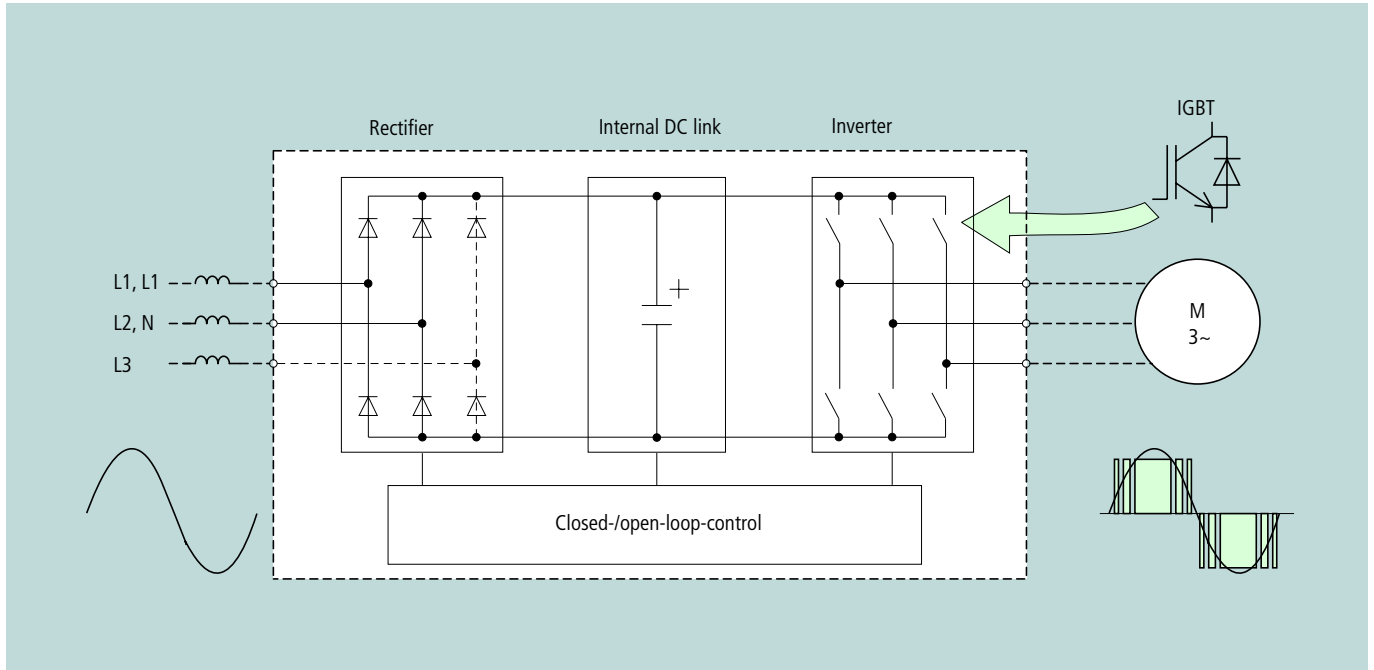

Method of operation

The frequency-controlled three-phase motor is today a standard component for infinitely variable speed and torque regulation, providing efficient, energy-saving power either as an individual drive or as part of an automated installation. The possibilities for individual or plant-specific coordination are determined by the specific features of the inverters and by the modulation procedure used.

Modulation procedure of inverter

An inverter basically consists of six electronic switches and is today usually made with IGBTs (insulated gate bipolar transistors). The control circuit switches the IGBTs on and off according to various principles (modulation procedures) to change the frequency inverter's output frequency.

Sensorless vector control

The switching patterns for the inverter are calculated with the PWM (pulse-width modulation) switching patterns. In voltage vector control mode, the amplitude and frequency of the voltage vector are controlled in dependence of slippage and load current. This allows large speed ranges and highly accurate speeds to be achieved without speed feedback. This control method (*U/f* control) is the preferred method for parallel operation of several motors with one frequency inverter.

In flow-regulated vector control, the active and reactive current components are calculated from the measured motor currents, compared with the values from the motor model and, if necessary, corrected. The amplitude, frequency and inclination of the voltage vector are controlled directly. This allows operation at the current limit and the achievement of large speed ranges and highly accurate speeds. Especially noteworthy is the drive's dynamic output at low speeds, for example in lifting and winding applications.

The key advantage of sensorless vector technology is that the motor current can be regulated to match the motor's rated current. This allows dynamic torque regulation to be implemented for three-phase asynchronous motors.

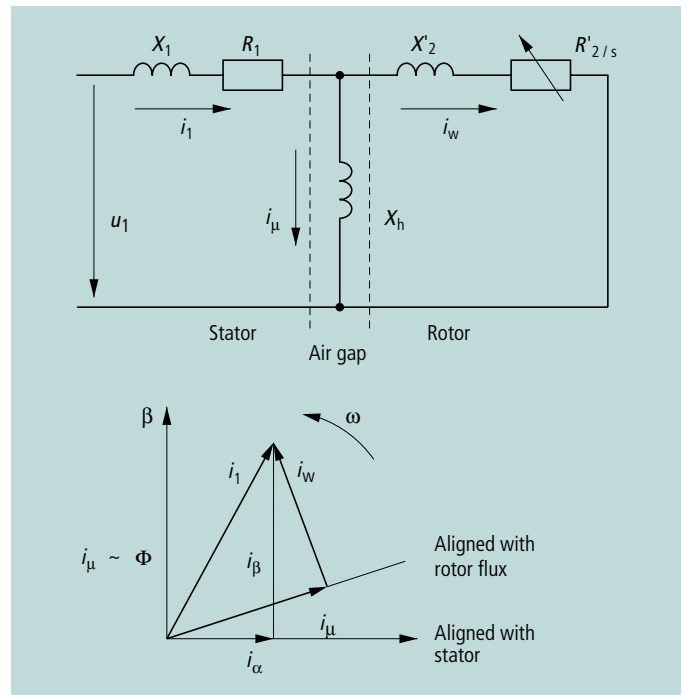

Simplified equivalent circuit of the asynchronous motor and associated current vectors

- i_1 = Stator current (phase current)
- i_μ = Flux-generating current component
- i_w = Torque-generating current component
- $R'_{2/s}$ = Slip-dependent rotor resistance

In sensorless vector control, the flux-generating current i_μ and the torque-generating current i_w are calculated from the measured stator voltage u_1 and stator current i_1 . The calculation is performed with a dynamic motor model (electrical equivalent circuit of the three-phase motor) with adaptive current regulators, taking into account the saturation of the main field and the iron loss. The two current components are set according to their value and phase in a rotating coordinate system (ω) to the stator reference system (α, β). The physical motor data required for the model is formed from the entered and measured (self-tuning) parameters.



EMC measures

The EMC (electromagnetic compatibility) of a device is its ability to withstand electrical interference (i.e. its immunity) while itself not emitting excessive electromagnetic interference into the environment. The IEC/EN 61800-3 standard describes the limit values and test methods for emitted interference and noise immunity for variable-speed electrical drives. The tests and values are based not on individual components but on a typical complete drive system.

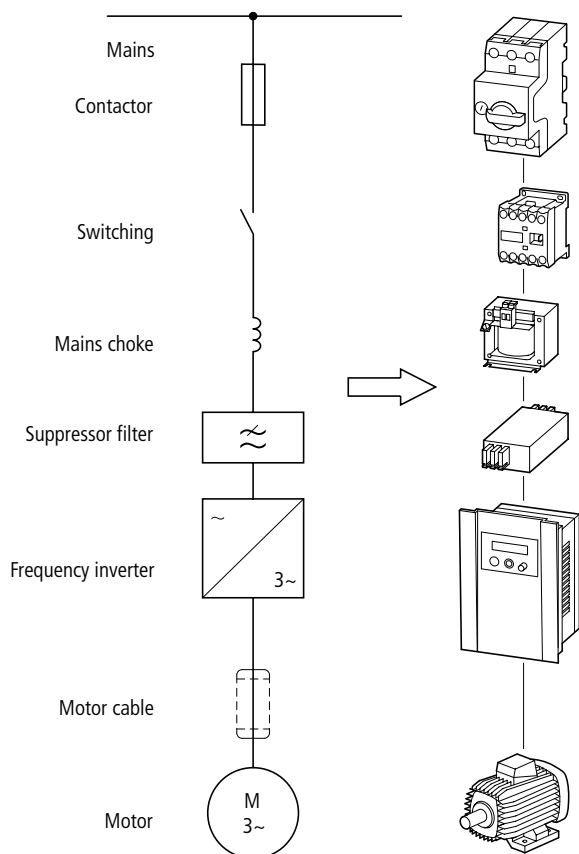

A detailed description of EMC-compliant mounting and connection is given in the manual (AWB) for each device.

Notes for correct installation of frequency inverters

For an EMC compliant installation, observe the information below. Electrical and magnetic disturbance fields can be limited to the required levels. The necessary measures work only in combination and should be taken into consideration at the engineering stage. To subsequently modify an installation to meet EMC requirements is possible only at considerable additional cost.

Measures for EMC-compliant installation

- 1. Earthing measures**
These must be implemented to comply with the legal standards and are a prerequisite for the effective use of further measures such as filters and screening. All conducting metallic enclosure sections must be electrically connected to the earth potential. For EMC, the important factor is not the cable's cross-section, but its surface, since this is where high frequency current flows to earth. All earthing points must be low-impedance, highly conductive and routed directly to the central earthing point (potential equalization bar or star earth). The contact points must be free from paint and rust. Use galvanized mounting plates and materials.
- 2. Screening measures**
These reduce the emitted interference (noise immunity of neighbouring systems and devices against external influences). Cables laid between the frequency inverter and the motor must be screened, but the screen must not be considered a replacement for the PE cable. Four-wire motor cables are recommended (three phases plus PE). The screen must be connected to earth (PES) at both ends with a large-area connection. Do not connect the screen with pigtailed. Interruptions in the screen, such as terminals, contactors, chokes, etc., must have a low impedance and be bridged with a large contact area. Control and signal lines must be twisted and may be double-screened, the inner screen being connected to the voltage source at one end and the outer screen at both ends. The motor cable must be laid separately from the control and signal lines (>10 cm) and must not run parallel to any power cables.

Screening of control and signal cables

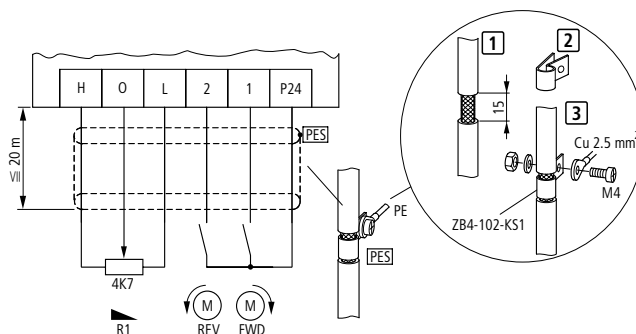

Example: DF5 frequency inverter, setpoint potentiometer R1 (M22-4K7) and ZB4-102-KS1 mounting accessories

- 3. Filter measures**
Radio interference filters and line filters (combinations of radio interference filter and mains choke) protect against conducted high-frequency interference (noise immunity) and reduce the frequency inverter's high-frequency interference, which is transmitted through or emitted from the mains cable, and which must be limited to a prescribed level (emitted interference).
Filters should be installed as closely as possible to the frequency inverter to keep the length of the connecting cable between frequency inverter and filter short. Cables longer than 30 cm must be screened. Filters produce leakage currents which, in the event of a fault (such as phase failure or load unbalance), can be much larger than the rated values. To prevent dangerous voltages, the filters must be earthed. As the leakage currents are high-frequency interference sources, the earthing connections and cables must have a low resistance and large contact surfaces. For leakage currents ≥ 3.5 mA, VDE 0160 and EN 60335 specify a protective conductor with a cross-section ≤ 10 mm² or the use of open-circuit monitoring.





4. Chokes

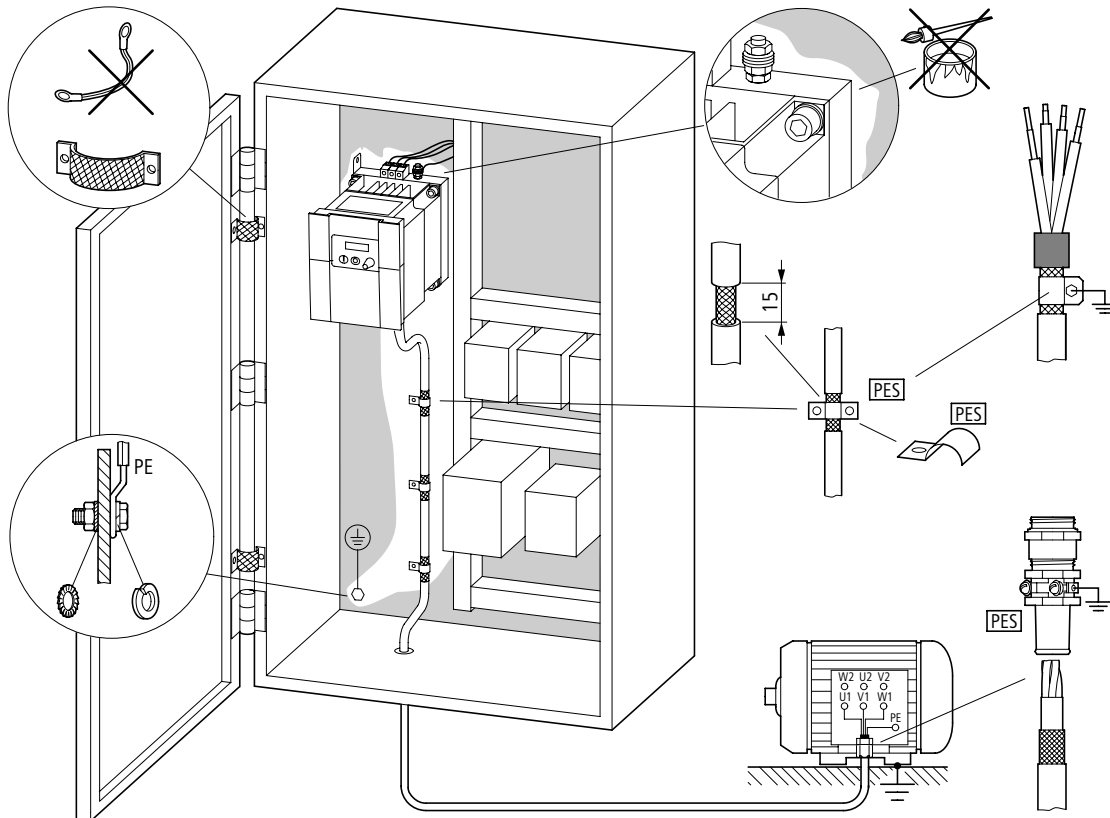

Fitted on the frequency inverter's input side, chokes reduce the current-dependent phase effect and improve the power factor. This reduces the current harmonics and improves the mains quality. The use of mains chokes is especially recommended where several frequency inverters are connected to a single mains supply point when other electronic devices are also connected to the same supply network. A reduction of the mains current interference is also achieved by installing DC chokes in the frequency inverter's DC link. At the frequency inverter's output, chokes are used if the motor cables are long and if multiple motors are connected in parallel to the output. They also enhance the protection of the power semiconductors in the event of an earth fault or short-circuit, and protect the motors from excessive rates of voltage rise ($> 500 \text{ V}/\mu\text{s}$) resulting from high pulse frequencies.



Moeller HPL0211-2004/2005



	Semiconductor contactors Soft starters DS4	Soft starters DM4
		
System overview	→ Page 17/2	→ Page 17/12
Selection data, assigned switching and protective elements	→ Page 17/4	→ Page 17/17
Ordering information	→ Page 17/6	→ Page 17/22
Mains connection	1 × 110 – 500 V, 50/60 Hz 3 × 110 – 500 V, 50/60 Hz	3 × 230 V – 460 V, 50/60 Hz
Rating range	10 A to 50 A at resistive load 2.2 kW to 30 kW (at 400 V) for three-phase asynchronous motors	4 kW to 250/500 kW (at 230 V) 7.5 kW to 500/900 kW (at 400 V)
Applications	<ul style="list-style-type: none"> • Heating installations • Galvanizing plants • Lighting systems • Fans and pumps • Conveyor belts • Door openers • Traction drives 	<ul style="list-style-type: none"> • Pumps/fans • Conveyors • Saws • Mixers • Crushers • Lighting installations • Heating installations
Field of application	<ul style="list-style-type: none"> • Contactless switching of resistive and inductive loads up to 50 A (single-phase, AC-51), or resistive and inductive loads (e.g. motors) up to 41 A (three-phase, AC-53) • Electronic starting of pump and fan motors up to 30 kW (soft starting) with built-in bypass for continuous operation • Reversing soft starters up to 22 kW for control valves, door control units and conveyor belts 	<ul style="list-style-type: none"> • Electronic starting of three-phase motors up to 900 kW (soft start) • Three-phase regulators for open- and closed-loop control of resistive and inductive loads (heating, lighting control, transformers) up to 900 A
Features	<ul style="list-style-type: none"> • Fast, contactless switching • Almost unlimited lifespan • Shock- and vibration-resistant • Absence of operating noise • Accurate repeatability 	<ul style="list-style-type: none"> • Ten preprogrammed standard applications, selectable with selector switch • Control signal terminals, galvanically isolated and pluggable • Controller section identical across the whole rating range • Slot for optional LCD keypad, serial interface or fieldbus interconnection • Cost-efficient in-delta circuitry
Notes	<ul style="list-style-type: none"> • Suppression of DC components during soft starting • Suppression of closing transients with inductive 3~ loads • Actuation with +24 V DC and 110 V to 240 V AC with separate switching thresholds for AC and DC • Direct control from a PLC possible through potential isolation between power section and control section 	<ul style="list-style-type: none"> • Parameter matching via LCD keypad or interface (optional)



	Frequency inverters DF5	Vector frequency inverters DV5
		
System overview	→ Page 18/2	→ Page 18/2
Selection data, assigned switching and protective elements	→ Page 18/6	→ Page 18/7
Ordering information	→ Page 18/12	→ Page 18/13
Mains connection	<ul style="list-style-type: none"> 1 × 230 V, 50/60 Hz 3 × 230 V, 50/60 Hz 3 × 400 V, 50/60 Hz 	<ul style="list-style-type: none"> 1 × 230 V, 50/60 Hz 3 × 230 V, 50/60 Hz 3 × 400 V, 50/60 Hz
Rating range	<ul style="list-style-type: none"> 0.18 kW to 2.2 kW (at 230 V) 0.37 kW to 7.5 kW (at 400 V) 	<ul style="list-style-type: none"> 0.18 kW to 2.2 kW (at 230 V) 0.37 kW to 7.5 kW (at 400 V)
Applications	<ul style="list-style-type: none"> • Fans • Pumps • Conveyor belts • Traction drives 	<ul style="list-style-type: none"> • Fans and pumps • Conveyor belts • Traction drives • Grinding mills • Agitators • Extruders • Lifting and conveying systems • Lifting gear
Field of application	<ul style="list-style-type: none"> • Speed control of three-phase motors up to 7.5 kW • General pump and fan applications in building services and industry • Standard drives in machine tools, processing and packaging machines in the food and beverages industry 	<ul style="list-style-type: none"> • Speed control of three-phase motors up to 7.5 kW • Numerous applications in the textile, paper and printing industries • Processing and milling machines in the metal industry • Conveyor belt drives, cranes and lifting machinery
Features	<ul style="list-style-type: none"> • U/f characteristic control from 0.5 Hz to 360 Hz with motor current monitoring and automatic voltage monitoring • 1.5-times starting torque for 60 s, every 600 s • Configurable digital and analog inputs/outputs • Relays/changeover contacts 	<ul style="list-style-type: none"> • Sensorless vector control • Autotuning (motor parameters) • Full torque from 0.5 Hz to 360 Hz • 1.5-times starting torque for 60 s, every 600 s • Starting torque about 200 % • Built-in braking transistor • Configurable digital and analog inputs/outputs • Relays/changeover contacts
Notes	<ul style="list-style-type: none"> • Built-in keypad with potentiometer • PID controller • RS 422 interface • PROFIBUS DP fieldbus module (external option) • Global standards (CE, UL, cUL, cTick) 	<ul style="list-style-type: none"> • Built-in keypad with potentiometer • PID controller • RS 422 interface • PROFIBUS DP fieldbus module (external option) • Global standards (CE, UL, cUL, cTick)



Moeller HPL0211-2004/2005

	Frequency inverter DF6 	Vector frequency inverters DV6 
System overview	→ Page 18/30	→ Page 18/30
Selection data, assigned switching and protective elements	→ Page 18/34	→ Page 18/35
Ordering information	→ Page 18/38	→ Page 18/39
Mains connection	3 × 400 V, 50/60 Hz	3 × 400 V, 50/60 Hz
Rating range	11 kW to 132 kW (at 400 V)	0.75 kW to 132 kW (at 400 V)
Applications	<ul style="list-style-type: none"> • Fans • Pumps • Conveyor belts 	<ul style="list-style-type: none"> • Fans and pumps • Conveyor belts • Traction drives • Grinding mills • Agitators • Extruders • Lifting and conveying systems • Lifting gear
Field of application	<ul style="list-style-type: none"> • Speed control of three-phase motors up to 132 kW • General pump and fan applications (square-law load characteristic) • Flow control in process engineering 	<ul style="list-style-type: none"> • Speed and torque regulation of three-phase motors up to 132 kW • Numerous applications in the textile, paper and printing industries • Machine tools • Processing and milling machines in the metal industry • Conveyor belt drives, cranes and lifting machinery
Features	<ul style="list-style-type: none"> • U/f characteristic control from 0.1 Hz to 360 Hz with motor current monitoring and automatic voltage monitoring • 1.2-times starting torque for 60 s, every 600 s • Built-in braking transistor (up to 15 kW) • Configurable digital and analog inputs/outputs • Three relays (changeover contacts) • Thermistor input (PTC) 	<ul style="list-style-type: none"> • Sensorless vector control • Autotuning (motor parameters) • 32-bit processor • Full torque at near 0 Hz (open-loop) • 1.5-times starting torque for 60 s, every 600 s • Starting torque about 200 % • Built-in braking transistor (up to 11 kW) • Configurable digital and analog inputs/outputs • One relay (changeover contacts) • Thermistor input (PTC)
Notes	<ul style="list-style-type: none"> • Plugged-in keypad with potentiometer • PID controller • RS 485/RS 232 serial interface • PROFIBUS DP fieldbus module (option for internal fitting) • User macro storage • Automatic energy-saving module • Global standards (CE, UL, cUL, cTick) 	<ul style="list-style-type: none"> • Plugged-in keypad with potentiometer • PI and PID controller • RS 485/RS 232 serial interface • PROFIBUS DP fieldbus module (option for internal fitting) • User macro storage • Synchronous speed control (optional) • Operation of several motors • Global standards (CE, UL, cUL, cTick)



15/16 Measurements conversion in SI units (Systeme Internationale d'Unitée)

Moeller HPL0211-2004/2005

Power

1 kW = 1.36 HP = 102 kpm/s = 1000 Nm/s
1 HP = 0.736 kW = 75 kpm/s = 736 Nm/s

Work

1 kWh = 3.6×10^6 J = 3.6×10^6 Nm
= 0.367×10^6 kpm
1 Ws = 1 J = 1 Nm = 0.102 kpm

Force

1 N = 0.102 kp
1 kp = 9.81 N

Torque

1 Nm = 0.102 kpm = 1 Ws
1 kpm = 9.81 Nm = 9.81 Ws

Pressure

1 Pa = 1 N/m²
1 bar = 10⁵ Pa
1 mm water column = 9.81 Pa

Moment of inertia

1 kgm² = 1 Ws² = 1 Nms² = 0.102 kpm²

Drive engineering formulae**Power (three-phase motors)**

$P_1 = U \times I \times \text{p.f.} \times \sqrt{3} \times 10^{-3}$
 $P_2 = P_1 \times h$
 P_1 = power input [kW]
 P_2 = power output [kW]
 U = voltage [V]
 I = current [A]
 $\cos \varphi$ = power factor
 h = efficiency

Power demand of some driven machines

Lifting motion

$$P = \frac{F \times \rho}{\eta} \times 10^{-3} \text{ [kW]}$$

Rotary motion

$$P = \frac{M \times n}{9550 \times \eta} \text{ [kW]}$$

Fan drive

$$P = \frac{V \times \rho}{\eta} \times 10^{-3} \text{ [kW]}$$

Pump drive

$$P = \frac{V \times \rho}{\eta} \times 10^{-3} \text{ [kW]}$$

P = power [kW]
 F = force [N]
 v = speed [m/s]
 h = efficiency
 M = torque [Nm]
 n = speed [1/min]
 V = delivery rate [m³/s]
 ρ = total back-pressure
to be overcome [N/m²]

Torque

Torque from motor rating

$$M = 9550 \frac{P_2}{n} \text{ [Nm]}$$

P_2 = motor power [kW]
 n = speed [r.p.m.]

Converting torque for different gear ratios

$$M_2 = \frac{M_1 \times n_1}{n_2}$$

n_1 = motor speed [r.p.m.]
 M_1 = motor torque [Nm]
 n_2 = working speed [r.p.m.]
 M_2 = torque at n_2 [Nm]

Moment of inertia

Relationship with flywheel effect

$$J = \frac{GD^2}{4}$$

J = moment of inertia [kgm²]
 GD^2 = flywheel effect [kpm²]

Moment of inertia of masses in linear motion in
relation to motor speed

$$J = 91.2 \times m \left(\frac{v}{n}\right)^2 \text{ [kgm}^2\text{]}$$

m = mass [kg]
 v = speed [m/s]
 n = motor speed [r.p.m.]

Converting moments of inertia to another speed for
different gear ratios

$$J_2 = J_1 \left(\frac{n_1}{n_2}\right)^2$$

n_1 = motor speed
 J_1 = moment of inertia at n_1
 n_2 = working speed
 J_2 = moment of inertia at n_2

Inertia factor

$$Fl = \frac{J_{\text{mot}} + J_{\text{zus}}}{J_{\text{mot}}}$$

J_{mot} = moment of inertia of motor
 J_{zus} = moment of inertia of driven machine

Starting time

$$t_a = \frac{Fl \times J_{\text{mot}} \times n}{9.55 \times M_b} \text{ [s]}$$

M_b = $M_{\text{mot}} - M_{\text{ctr}}$ [Nm]
 Fl = inertia factor
 J_{mot} = moment of inertia of motor [kgm²]
 n = motor speed [r.p.m.]
 M_b = accelerating torque [Nm]
 M_{mot} = motor moments at startup (averaged)
 M_{ctr} = counter-torque at startup (averaged)

