



---

# MVision

---

Display PLC

PLC-Line compact

## Device Description

### HPG-200



## Copyright

### Keep documentation for future use!

This documentation is the intellectual property of **Micro Innovation AG**, which also has the exclusive copyright. Any modification of the content, duplication or reprinting of this documentation, as well as any distribution to third parties can only be made with the express permission of **Micro Innovation AG**.

**Micro Innovation AG** does not accept any liability for damages arising from the use of any incorrect or incomplete information contained in this documentation or any information missing therefrom.

**Micro Innovation AG** reserves the right to make complete or partial modifications to this document.

All brand and product names are trademarks or registered trademarks of the owner concerned.

## Proper use

The device must only be used for the applications specified in the device description and only in conjunction with the components recommended by Micro Innovation AG.

## Warning

Trouble-free and safe operation of the product can only be ensured if the measures relating to proper transport, storage, assembly, installation and careful operation are strictly observed.

The device must not be switched on when it is covered with condensation. When changing its location from cold to warm allow the device to acclimatize to the new conditions before commissioning.

No warranty claims will be recognized for faults arising from the improper handling of the device.

The device should not be used for the implementation of any safety functions relating to the protection of personnel and machinery.

No liability is accepted for claims for damages arising from a failure or functional defect in the device.

All data specified in this document does not represent guaranteed specifications in the legal sense.

## Safety instructions for the user

This device description contains the information required for the proper use of the products described therein. Sections 1 to 12 address technically qualified personnel and Section 13 onwards addresses personnel not requiring any technical knowledge.

Qualified personnel in the sense of the safety instructions given in this device description or on the product itself are persons who:

as engineering personnel are either familiar with the safety concepts of automation,

or as operating personnel, are instructed in the use of automation components and are familiar with the contents of this device description relating to the operation of the device,

or as commissioning or service personnel are suitably trained for the repair of automation devices and are authorized to commission circuits and devices/systems in accordance with standard safety engineering principles.

## Contents

<b>1</b>	<b>Explanation of symbols</b> .....	<b>7</b>
<b>2</b>	<b>Introduction</b> .....	<b>9</b>
<b>3</b>	<b>Device versions</b> .....	<b>11</b>
3.1	Specifications.....	11
3.2	Accessories.....	12
3.3	Designing.....	12
<b>4</b>	<b>Features</b> .....	<b>13</b>
<b>5</b>	<b>Commissioning</b> .....	<b>15</b>
5.1	Overview of connections.....	15
5.2	Inserting the CompactFlash™ .....	16
5.3	Inserting the battery .....	17
5.4	Connecting the power supply.....	18
5.5	Preparing the shield connections.....	19
5.6	Connecting the programming interface.....	20
5.7	CAN interface.....	21
5.8	Connection for keyboard.....	24
5.9	Connection for ProfibusDP master (Optional).....	24
5.10	Connection for COM1 serial interface (RS232).....	24
<b>6</b>	<b>Operation</b> .....	<b>25</b>
6.1	Startup behaviour.....	25
6.2	Shutdown behaviour .....	25
6.3	PLC operating states .....	26
6.4	Changing operating mode.....	27
6.5	Startup behaviour/startup.....	28
6.6	Program transfer .....	28
6.7	System settings.....	29
<b>7</b>	<b>Mounting instructions</b> .....	<b>31</b>
7.1	General mounting instructions .....	31
7.2	Mounting in the front panel .....	31
7.3	Front panel cutout.....	32
7.4	Mechanical dimensions.....	33
7.5	External fan.....	34
<b>8</b>	<b>Notes on the touch screen</b> .....	<b>35</b>
8.1	Basic touch screen function.....	35
8.2	Power up function test .....	35
8.3	Cleaning and maintenance of the touch screen.....	35
<b>9</b>	<b>Display, backlight, contrast</b> .....	<b>37</b>
9.1	Contrast .....	37
9.2	Backlight .....	37
<b>10</b>	<b>Diagnostics</b> .....	<b>37</b>
<b>11</b>	<b>Maintenance and repair</b> .....	<b>39</b>
<b>12</b>	<b>Technical data</b> .....	<b>41</b>
<b>13</b>	<b>Disposal</b> .....	<b>43</b>

<b>14</b>	<b>EU Conformity .....</b>	<b>43</b>
<b>15</b>	<b>Revision history .....</b>	<b>45</b>
<b>16</b>	<b>Alphabetical index .....</b>	<b>47</b>

## 1 EXPLANATION OF SYMBOLS

### Danger warnings

The following information is for your personal safety and the prevention of damage to the device described or connected devices.

Safety instructions and warnings for the prevention of danger to the life and health of users or service personnel, and for the prevention of damage are highlighted in this document by the following pictograms. "Warning" and "Information" pictograms are shown in this document.

### Warnings indicate the following:

Death, serious injury or substantial material damage may occur if the related safety measures are not implemented.

The individual "Warning" pictograms have the following meaning:



#### Caution! General!

An instruction to be observed in order to ensure protection against hazards and the safe operation of the device. The specified procedure should be observed.



#### Caution! Electric shock!

Persons may be exposed to dangerous voltages that occur in electrical systems. There is a danger of electric shock if a live part is touched.



#### Caution! Observe ESD measures!

Electrostatic discharge may destroy electronic components.

### Information pictograms indicate the following:

Important information about the product or the relevant section of the document, requiring the particular attention of the reader.

The "Information" pictogram has the following meaning:

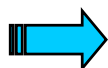

Indicates important and instructional information.



## 2 INTRODUCTION

### Features of the HPG-200 devices

- PC-COMPATIBLE COMPUTER CORE
- STANDARD FIELDBUS INTERFACES  
CANopen, PROFIBUS-DP (Option)
- ETHERNET ONBOARD
- EXCHANGEABLE COMPACTFLASH™
- PROGRAMMABLE TO IEC61131 (IL, LD, FBD, SFC, ST, CFC)
- INFRARED TOUCH-TECHNOLOGY
- IP65 FRONT

The HPG-200 series display PLC combines in one device a graphical operator panel with touch screen and a powerful compact PLC. This future-oriented device concept offers a wide range of automation and networking options.

The PLC is programmed in compliance with the IEC61131 industrial standard. The graphical screen masks are designed effectively and simply using the visualization tool EPAM and EXCEL. This makes the display PLC a universal device for automation applications.

The integration of third-party systems (I/Os, drives etc.) via standard fieldbus interfaces (CANopen) and their integration in the overall system offers access to a wide range of process optimized peripheral components.

Thanks to the integrated Ethernet interface the HPG-200 series display PLCs have the capabilities for Web applications.

### Application range

The HPG-200 series display PLC is designed for controlling, operating and monitoring machines and plants. The integrated infra-red touch technology ensures fast and simple operation. The rugged and compact design allows the implementation of applications that were previously impossible due to the space and cost requirements involved.

The high degree of protection (front IP65) and the omission of any moving parts (hard disks, fans) makes the devices ideal for robust use in rugged industrial environments directly at the machine.

The devices can be installed in control panels or control desks without any problem.

This device description is a reference for the technical data, installation, terminals, commissioning, operation, and maintenance of all HPG-200 versions. The illustrations in this document are for the 5.7" device version (➔ Section 3), unless otherwise stated. The designation and function of the connections and signals are the same for all versions.



### 3 DEVICE VERSIONS

The term HPG-200 stands for the following versions.

HPG-200 Device types				
Type designation	Display	Fieldbus	Resolution	Power supply
<b>HPG-210-57SQBy-01</b>	5.7" STN mono	CAN	¼-VGA (320 x 240)	24 VDC
<b>HPG-230-57SQBy-01</b>	5.7" STN color	CAN	¼-VGA (320 x 240)	24 VDC
<b>HPG-230-57SQBy-02</b>	5.7" STN color	CAN ProfibusDP master	¼-VGA (320 x 240)	24 VDC

The following front plate versions are available:

Front plate type (y)	<b>A</b>	Standard plastic front with MI membrane seal

#### 3.1 SPECIFICATIONS

<b>HPG-210-57SQBA-01</b>	Art.Nr : <b>85 24 000000</b>  5.7" STN mono, SC400 66MHz, 16MB DRAM, 32kB NVSRAM, CF-Interface, IR-Touch Interface: CAN, 1 x RS232, Ethernet 10MB without CompactFlash and runtime system
<b>HPG-230-57CQBA-01</b>	Art.nr : <b>85 24 000100</b>  5.7" STN color, SC400 66MHz, 16MB DRAM, 32kB NVSRAM, CF-Interface, IR-Touch Interface: CAN, 1 x RS232, Ethernet 10MB without CompactFlash and runtime system
<b>HPG-230-57CQBA-02</b>	Order No.: <b>85 24 000110</b>  5.7" STN color, SC400 66MHz, 16MB DRAM, 32kB NVSRAM, CF-Interface, IR-Touch Interface: CAN, ProfibusDP-Master , 1 x RS232, Ethernet 10MB without CompactFlash and runtime system

### 3.2 ACCESSORIES

<b>Runtime system</b> (on CompactFlash 8MB)	Order No.: <b>90 24 000001</b>  MWare Runtime System HPG-200  Consisting of: - IEC61131-RTS - EPAM-RTS - Pre-installed on CompactFlash 8MB
<b>Battery</b>	Order No.: <b>45 60 000001</b>  Battery  Spare battery (Type → Section12)
<b>Programming cable</b>	Order No.: <b>70 10 000020</b>  Programming cable RS232 Null modem (serial connection)  Order No.: <b>70 10 000021</b>  RJ45 programming cable Ethernet 1:1 (Ethernet connection via hub)  Order No.: <b>70 10 000022</b>  RJ45 programming cable Ethernet crosslink (direct Ethernet connection)

### 3.3 DESIGNING

<b>MWare Development System</b> (on CD)	Order No.: <b>91 24 000002</b>  MWare Development System CD  Consisting of: - CoDeSys -> IEC61131 software - Easy PageMachine -> EPAM development environment (only for HPG devices) - Documentation in PDF format
--	---

## 4 FEATURES

Feature		Comment	
<b>Display</b>	Graphic	Size	5.7"
	Type	STN	16 greyscales/16 colors
	Resolution	Pixels	320 x 240
<b>Touch</b>	Infra-red touch	Resolution	45 x 33
<b>PLC</b>	Languages	IEC61131	IL, LD, FBD, SFC, ST, CFC
	Debug options	Yes	Online change, breakpoint, trace, flow control
	PLC program	KByte	512
	PLC data	KByte	256
	Retain data	KByte	Max. 32 (Default: 16KB)
	Multi-tasking	Yes	
	Network variables	Yes	Ethernet or CAN
	Cycle time/k instructions	ms	Normally 0.8ms
Real-time clock	Yes	Battery-backed	
<b>Visualization</b>	Memory for visualization	MByte	2 (Ord. No.: 90 24 000001)
	Messages	Number	Normally 2000
	Alarms	Number	Max. 1008
	Alarm history	Number	Max. 512
	Process variables	Number	Normally 1000
	Process screen pages	Number	Normally 300
	Online languages	Number	Normally 5
	Character languages	Yes	e.g. Chinese, Japanese,...
	Recipes	Yes	Can be edited in ASCII text format
	Password	Yes	Normally 10 levels
<b>Communication</b>	COM1 (RS232)	kBit/s	Max. 38.4KB
	CAN (CANopen)	kBit/s	CAN master, max. 500 Default: 125
	Ethernet	MBit/s	10
	ProfibusDP	MBit/s	Max. 12 (Ord. No.: 85 24 000110)
	Remote maintenance	Yes	With external modem serial or via Ethernet (e.g. with ISDN router)
<b>Exchangeable memory</b>	CompactFlash™	MByte	Up to 64 MB
	Software update via CompactFlash™	Yes	PLC project, visualization, MWare runtime system

The number of designable process screens, messages, languages etc. is restricted by the memory available for visualization. The memory required per image greatly depends on the application concerned, and is mainly determined by the size and number of images (PCX) used. 50 KBytes and more may be required for showing an image with a resolution of 320\*240 pixels. If an image of this size is designed on each screen page, the number of possible screen pages would be less than 40.

These specifications are based on typical sizes that are used in real projects. With sufficient memory, these values can be exceeded. However, this will result in longer reaction times and screen change times. (see also Easy PageMachine (EPAM) manual)

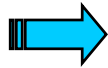

**In the system the PLC program has priority over the visualization. Therefore the PLC program should not take up all the CPU time otherwise operation and visualization will be impossible or very slow. Delays in the visualization may occur during file transfers (such as project downloads, FTP, WEB servers), or during communication with the development system (e.g. PLC debugging) as the visualization has the lower priority.**

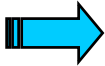

**CompactFlash™ memory media are NOT suitable for cyclical data logging due to the limited number of write cycles (normally 100,000).**

## 5 COMMISSIONING

### 5.1 OVERVIEW OF CONNECTIONS

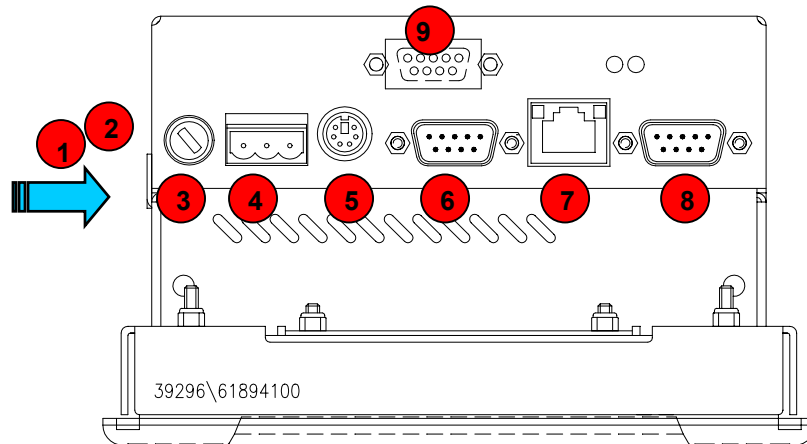

No.	Element	Description
1	Battery for retain PLC data and real-time clock	Page 17
2	CompactFlash™ Interface	Page 16
3	Fuse	Page 18
4	24VDC power supply	Page 18
5	PS2 keyboard	Page 24
6	CAN connector 9-pole Sub-D, male	Page 21
7	RJ45 Ethernet	Page 20
8	RS232 COM1	Page 24
9	ProfibusDP/SIO/AUX (Option)	Page 24

## 5.2 INSERTING THE COMPACTFLASH™

The HPG-200 series devices use a CompactFlash™ card for storing the runtime system, the application or data (e.g. recipes). A CompactFlash™ card with the pre-installed HPG-200 MWare Runtime System (e.g. Ord. No. 90 24 000001) must therefore be inserted before initial commissioning.

To do this, undo the cover of the CompactFlash interface and insert the appropriate HPG-200 MWare Runtime System (e.g. Ord. No. 90 24 000001). The cover must be refitted and fastened.

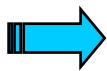
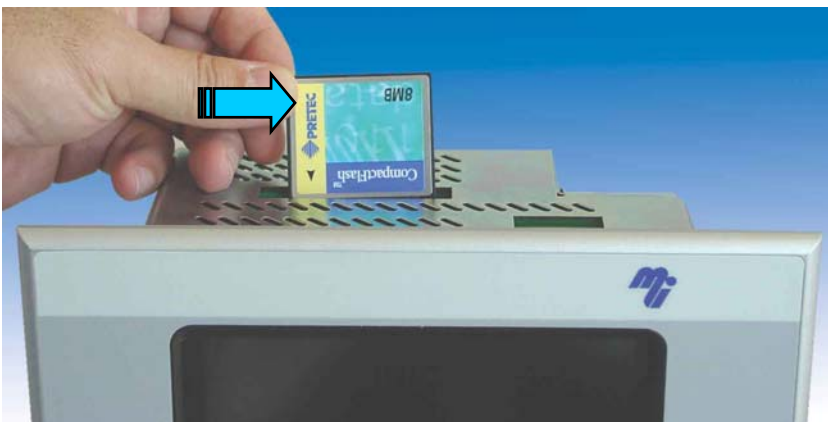
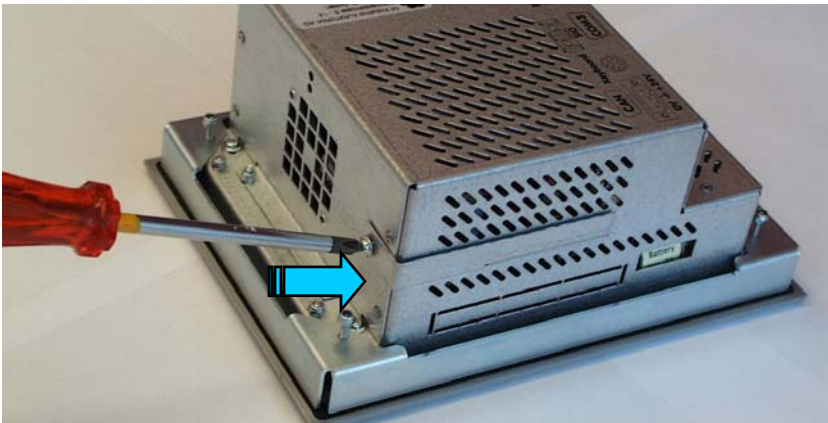

**The CompactFlash™ must only be fitted or removed with the device power supply switched off. The device cannot run without a CompactFlash™ card. Correct functioning of the device can only be ensured by using CompactFlash™ cards obtained from the original accessories.**

### 5.3 INSERTING THE BATTERY

The battery supplied (Ord. no. 45 60 000001) is used for backing up the real-time clock and the retain PLC data. The battery is already inserted when delivered. It can be replaced in the following way:

1. Connect the device to power supply at least 10 minutes
2. Unplug the power supply (retain data will be stored at least 2 minutes)
3. Replace battery

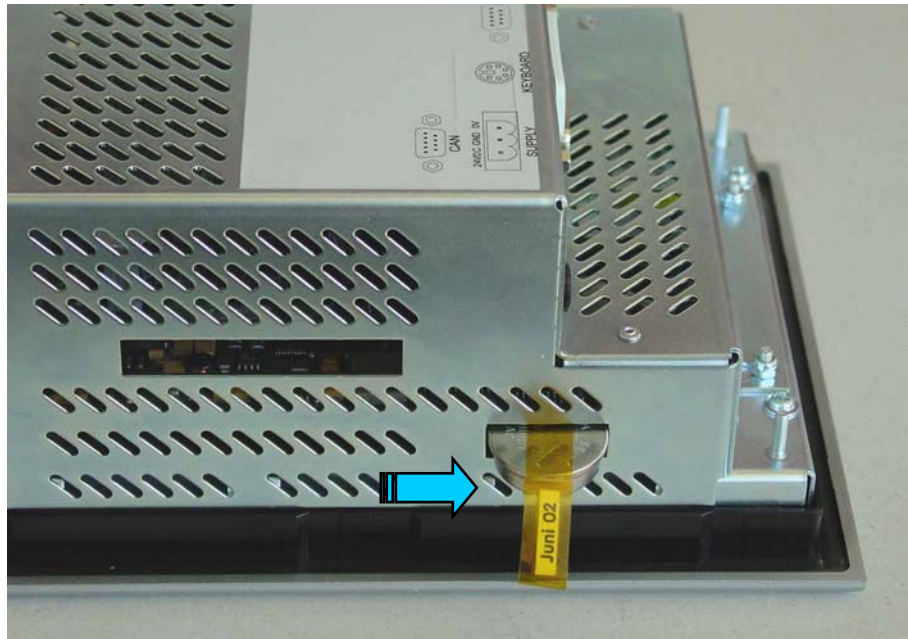

## 5.4 CONNECTING THE POWER SUPPLY

The HPG-200 device belongs to protection class 3. The system power supply must be provided with a 24VDC **SELV** voltage (→ Section 12). The power supply is not isolated. The 0V connection is directly connected to the housing potential. The device is protected with a 1.6 A slow fuse (note disconnection capacity → Section 12). A reverse polarity protective device is used to protect the device in the event of reversed poles. Operation, however, is only possible if the connection was made correctly. Connections for the HPG-200 must comply with specific, local regulations.

The connection must be made as follows:

1. The cross-section of the power supply cable must be at least 0.75 mm<sup>2</sup> and a maximum of 2.5 mm<sup>2</sup>.
2. A flexible lead or wire can be used for the connection.
3. The current consumption (→ Section 12) must be taken into account when implementing the power supply. The functional earth is not compulsory for operation. The GND connection is directly connected to the housing potential

The plug connector (socket connector screw with terminals) is supplied with the device for connection.

### Connector assignment



(plug connector: Phoenix MSTB 2.5/3-ST-5.08  
Phoenix Ord. No. 1757022)

Designation	Function
+24 VDC	+24VDC power supply
GND	Functional ground
0V	0V power supply

## 5.5 PREPARING THE SHIELD CONNECTIONS

The preparation of the data and signal cables is an important factor for the electromagnetic compatibility (EMC) of the HPG-200, both in terms of interference immunity and emission.

The **RS232** interface and **CAN** interface are connected via D-Subminiature plug connectors in accordance with DIN 41652. Only use metal or metallised connector casings with a cable clamp for strain relief fastened or clamped on the connector. The clamping of the cable shield ensures an optimum contact area and a low impedance connection with the connector casing of the HPG-200 display PLC.

The following procedure is recommended for making the low-impedance connection for the cable shield:

1. Strip the cable.
2. Shorten the exposed shield braid by approx. 3 cm.
3. Turn back the braid over the cable sheath.
4. Use a heat shrinkable tubing or rubber grommet to cover the exposed cable sheath with the folded back shield braid so that 5 to 8 mm of exposed cable shield is left at the sheath end and is cleanly covered at the back.
5. Fit the connector
6. The cable is then fastened at the exposed shield braid and the cable sheath below it directly underneath the cable clamp strap of the connector casing.

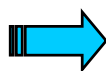
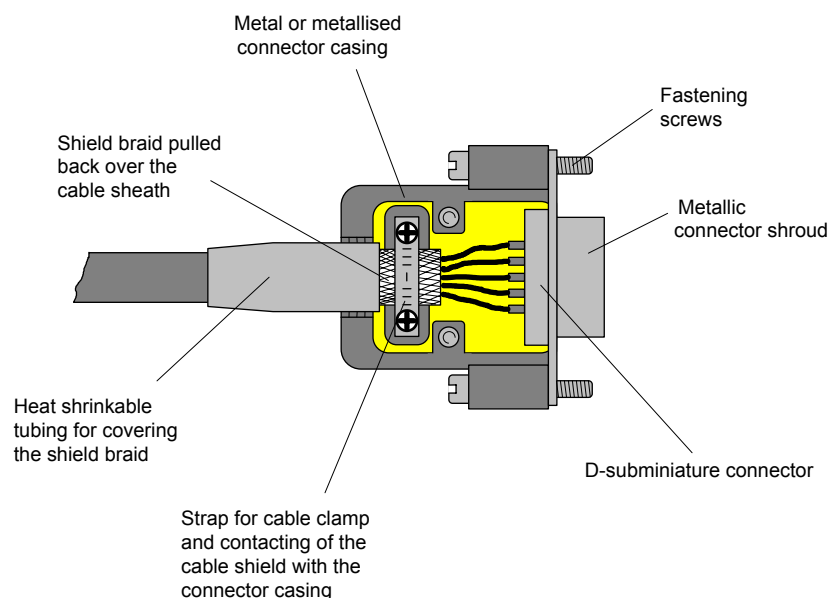

**Connection work should be carried out with special care in order to ensure trouble-free operation. The EMC values stated in the technical data can only be guaranteed if the cables are prepared according to the following specifications.**

## 5.6 CONNECTING THE PROGRAMMING INTERFACE

The programming is carried out via the standard Ethernet interface (RJ45). The connection to the programming PC is implemented using a standard Ethernet cable (1:1) via a hub or directly using a crosslink cable. The cables are also available as an accessory (➔ Section 0).

Before the device is connected to the Ethernet network, the IP address of the device and the programming PC must be set (➔ Section 6.7).

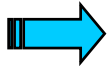

**IP addresses can be obtained from your system or network administrator. IP addresses must be uniquely defined in an Ethernet network. The IP address of all networks and of the programming PC must be in the same subnetwork (e.g. 192.168.0.xxx).**

### Connector assignment

**RJ45  
connector**

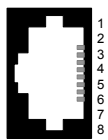

Socket, 8pole  
RJ45

Pin No.	Signal	Description
1	TXD	
2	TXD+	
3	RXD+	
4	-	
5	-	
6	RXD	
7	-	
8	-	

Alternatively, programming can also be implemented via the RS232 serial interface on COM1. This interface is not isolated. The GND connection is implemented directly on the housing potential (➔ Section 12).

Cables connected to the programming interface (Ethernet or serial) must be laid separately from the low-voltage cables.

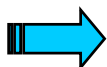

**A detailed description of the project download is provided in the “MWare and MSystem” system description or in the appropriate software documentation.**

## 5.7 CAN INTERFACE

The communication interface is defined in accordance with the CiA CAN Specification V2.0 part B. The fully-integrated CAN unit supports the sending and receiving of frames with an 11-bit identifier. The type of configuration selected depends on the software protocol. The baud rate can be selected in a wide range, and only the standard CiA baud rates are implemented. The HPG-200 is the master on the CAN bus.

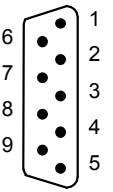
<b>CAN connector</b>			
Sub-D 9 Pole male			
<b>Connector</b>	Pin No.	Assignment	Function
	1	-	
	2	CAN LOW	Negative data signal
	3	GND	Signal Ground (ground potential)
	4	-	
	5	-	
	6	GND	Signal Ground (ground potential)
	7	CAN HIGH	Positive data signal
	8	-	
	9	-	
	Case	Case	Cable shield

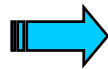

**The CAN interface is isolated.**

**The max. baud rate is 500kBit/s.**

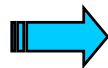

**The terminating resistor must be implemented externally, e.g. in the connector, and is not part of the device.**

**The CAN connector is not provided with a supply for third-party devices.**

**A detailed description of the wiring is provided in the "MWare and MSystem" system description**

**Wiring instructions**

The stations on the bus system are connected via fieldbus lines complying with ISO 11898. The cables must accordingly have the following electrical characteristics:

Parameter	Abbreviation	Unit	Value min.	Value nom.	Value max.	Note
Impedance	Z	$\Omega$	108	120	132	Measured between two signal lines
Specific resistance		m $\Omega$ /m		70		For the receiver module, the differential voltage on the bus cable depends on cable resistance between it and the sender
Cable delay		ns/m		5		The minimum delay between to points on the bus is 0. The maximum delay is determined by the bit timing and the delays of the sender and receiver circuits

The figure shows the minimum wiring with shielding between two bus stations with the Sub-D connector as an example. A bus terminating resistor (120 Ohm between Pin 2 and Pin 7 of the Sub-D connector) must be connected at the beginning and the end of each CAN bus. Do not swap around the two signal wires!

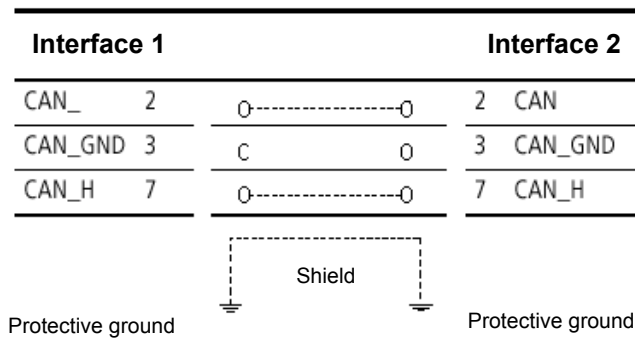

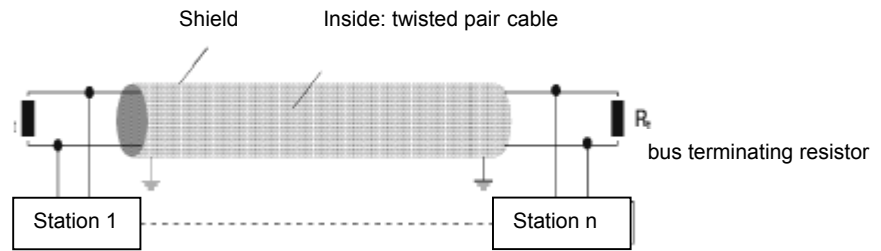

Pin 3 and 6 (CAN\_GND) are both connected internally with the CAN Ground. Pins 4, 5 and 8 must *not* be connected! The CAN bus driver is fed internally.

### Baud rate and cable lengths

Baud rate	Max. length
20kBit/sec	2500m
25kBit/sec	2000m
50kBit/sec	1000m
100kBit/sec	650m
125kBit/sec	500m
250kBit/sec	250m
500kBit/sec	100m

**Commissioning**

**5.8 CONNECTION FOR KEYBOARD**

The keyboard terminal is PC-compatible (PS2) and is only provided for testing and service tasks.

**Connector**

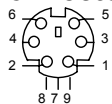

Socket 6pole  
MiniDIN

Pin No.	Signal	Description
1	KBDATA	
2	-	
3	KBGND	
4	KBVCC	Fused
5	KBGND	
6	-	

**5.9 CONNECTION FOR PROFIBUSDP MASTER (OPTIONAL)**

The ProfibusDP master interface is only available in the version  
Ord No.: 85 24 000110

**Socket**

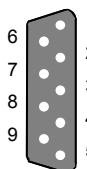

Socket 9pole  
SubD

Pin No.	Signal	Description
1	-	
2	-	
3	RXD/TXD+	
4	-	
5	GND	
6	+5V	Fused, not isolated
7	-	
8	RXD/TXD-	
9	-	

**5.10 CONNECTION FOR COM1 SERIAL INTERFACE (RS232)**

**Connector**

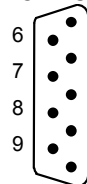

Connector  
9pole  
SubD

Pin No.	Signal	Description
1	DCD	
2	RXD	
3	TXD	
4	DTR	
5	GND	
6	DSR	
7	RTS	
8	CTS	
9	RI	

## 6 OPERATION

### 6.1 STARTUP BEHAVIOUR

After power on, the HPG-200 carries out a system test. The PLC does not switch to Run or Stop until no hardware errors have been found. The system test includes the following:

- Memory test
- Flash disk test

#### Start messages

Version display of firmware:

Module name	Version	Size
VxWorks	V 1.4.0005	974872
ethercfg.out	V 1.1	2192
plcvxw.out		350055
cstitf.out	V 1.2.0001	12082
cstcan.out	V 2.3.0003	211286
cstepam.out	V 1.1	5177
epam.out	V 3.0.0168	824847
restore.out	V 1.0.0001	5597
drvarti.out	V 1.0.0015	99292
chttpd.out	V 1.0.0007	17307

### 6.2 SHUTDOWN BEHAVIOUR

Voltage dips of  $\leq 10\text{ms}$  at 24V (→ Section 12) are bridged by the power supply unit. Longer voltage dips will cause the PLC to be reset automatically.



**Writing data to the CompactFlash™ during a power supply failure will cause the data to be lost!**  
**The EPAM visualization software therefore makes a copy of the file in the directory C:\BACKUP before every write operation. These files are restored if necessary at the start.**

## 6.3 PLC OPERATING STATES

### Power on

In Power on status, there is no user program in the PLC. In this status it is possible to load a program onto the PLC. The Power on status is indicated in the programming software.

### Stop

The Stop operating status has the following features:

- A user program is stored on the PLC
- The user program is not running

The Stop status is selected:

- After power on, if the entry Startup=STOP has been made in the PLC.INI file (→ Section 6.7)
- After power on, if the entry Startup=AUTO has been made in the PLC.INI file (→ Section 6.7), and the PLC was in Stop status at the last online access via the programming software
- Via the programming software in the PC
- After the cycle time is exceeded

### Run

In RUN status, the user program is processed cyclically.

The RUN operating status is selected:

- After power on, if the entry Startup=WARM has been made in the PLC.INI file (→ Section 6.7) (Default)
- Via the programming software in the PC
- After power on, if the entry Startup=AUTO has been made in the PLC.INI file (→ Section 6.7), and the PLC was in Run status at the last online access via the programming software

### System Fault SF

The following system faults can occur (→ Section 10):

- Hardware fault
- Firmware system faults

## 6.4 CHANGING OPERATING MODE

The operating mode of the HPG-200 devices is changed via the PLC.INI configuration file in the C:\MCONTROL directory on the CompactFlash™ or via the programming software.

### PLC.INI configuration file:

The following entries can be made in the [BOOT] section:

Startup=WARM	...PLC starts in RUN mode (Default)
Startup=STOP	...PLC starts in STOP mode
Startup=AUTO	...PLC startup behaviour can be controlled by the programming software. The PLC starts up in the status set at the last online access.

### Programming software:

#### **Reset**

This command resets all variables to the value with which they were initialized apart from the retain variables (RETAIN, PERSISTENT). Variables not explicitly assigned an initialization value are set to the standard initial values (integers for example to 0). CoDeSys outputs an appropriate safety prompt before all variables are overwritten. This also happens when there is a power failure or when the PLC is switched off and on again (warm start).

Use the command 'Online', 'Start' to restart the PLC and resume program processing.

#### **Reset Cold**

This command resets all variables to their initial values regardless of whether they are RETAIN variables or not. Only persistent variables retain the value they had before the reset.

#### **Reset Original**

This command resets all variables including retain variables (RETAIN and PERSISTENT) to their initial values and deletes the user program on the PLC. The PLC is reset to its basic setting.

#### **Start**

The command starts the running of the user program in the PLC.

The command can be executed directly after the commands 'Online', 'Load' or after the user program was stopped in the PLC via the commands 'Online', 'Stop', or if the user program is at a break point, or after the commands 'Online', 'Single Cycle'.

A detailed description of the online functions is also provided the MWare/CodeSys manual.

## 6.5 STARTUP BEHAVIOUR/STARTUP

After power on, the user program is loaded from the CompactFlash™ into the RAM and the PLC is started.

### Procedure:

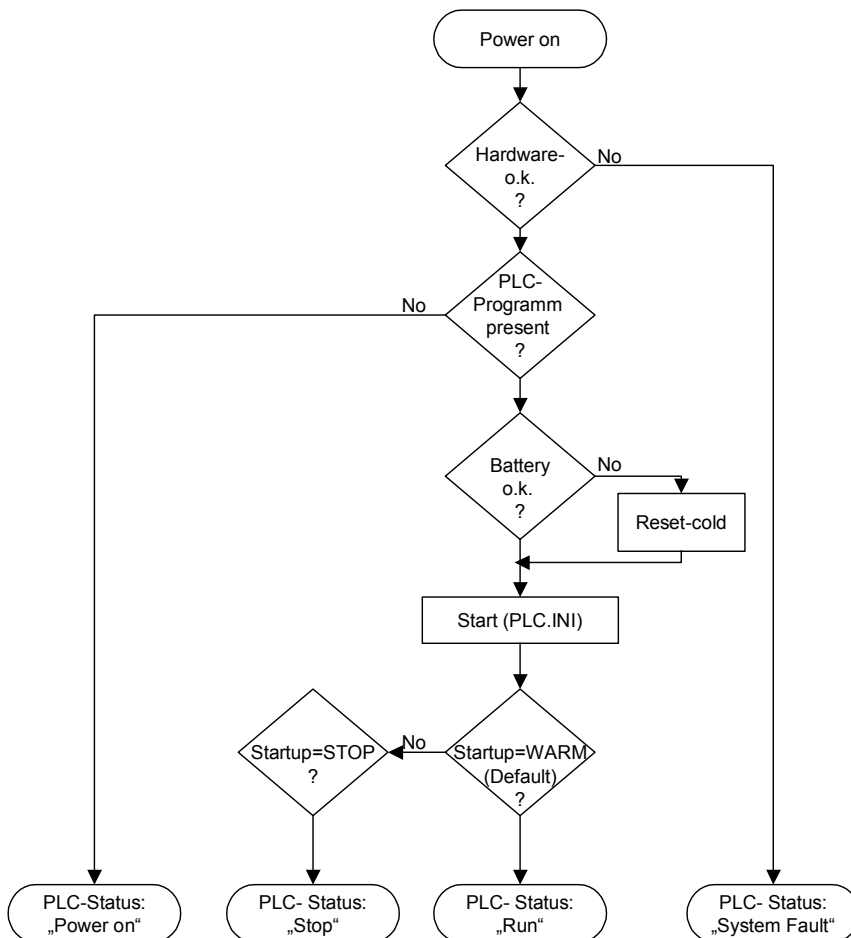

## 6.6 PROGRAM TRANSFER

If the user program was compiled error-free on the programming device (PC), it can be loaded into the working memory of the HPG-200 and then started.

### **PC → PLC:**

When logging on to the PLC from the PC, the program in the PLC is compared to the program in the PC. If they are not the same, a prompt will ask whether the program is to be overwritten. If this prompt is confirmed, the PLC switches to Stop status and the new program is loaded into the working memory. (Program transfer/Online Change see also the MWare/CodeSys manual).

### **PC → PLC and CompactFlash™:**

The user program is saved on the CompactFlash™ by generating a boot project.

## 6.7 SYSTEM SETTINGS

The HPG-200 devices are supplied with a startup application that allows the following system settings:

- IP address setting (Default: 192.168.0.99)
- Gateway address setting
- Date and time setting
- Contrast and backlight setting

These system settings must be made in the visualization application of the user. The start application is supplied with EPAM for this purpose, and can be used as a basis for user applications.

After a new project is downloaded, the start application is no longer available. The system settings can therefore only be carried out if this is implemented in the application.

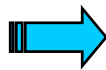

**The system settings must be implemented in the visualization application. After a new project is downloaded, the start application is no longer available! The system settings are saved in the CONFIG.INI file.**

The subnetwork mask is defined automatically on the basis of the class of the IP address. For the default IP address the subnetwork mask is: 255.255.255.0

### PLC.INI configuration file

The PLC.INI file is supplied in the following state:

```

*****
# PLC.INI
#
# Note: Preserving the original configuration is recommended
#
*****

[BOOT]
Startup=WARM      # Startup mode of PLC boot project: WARM (default) / STOP / AUTO
                  # Note: Startup mode AUTO preserves the PLC mode of the last online session

[CONFIG]
RetainMode=CST_RETAIN_CYCLE # Retain memory saved at end of PLC cycle (CST_RETAIN_CYCLE=default)
RetainSize=0x8000
RetainAddress=0xD8000

CAN
CANbaudrate=500      # Startup CAN baud rate (no used with CoDeSys CAN Configurator)
CANinQueueSize=16

[EPAM]
PrioEPAM=254      # Priority of EPAM task (254=default)
PrioTOUCH=253     # Priority of touch task (should be lower than PrioEPAM) (253=default)
DelayTicksEPAM=1  # Number of system ticks that EPAM suspends at the end of the EPAM loop (1=default)

```

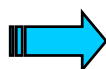

**Only the [BOOT] entry can be changed by the user in the PLC.INI configuration file. All other settings must not be changed.**



## 7 MOUNTING INSTRUCTIONS

### 7.1 GENERAL MOUNTING INSTRUCTIONS

All HPG-200 series devices are mounted from the front, i.e. in a control panel. They are fastened from the rear with the supplied fixing frame and 4 securing nuts.

All HPG-200 series devices can be operated up to a maximum ambient temperature of 45°C (→ Section 12). The ambient temperature stated applies to the area in the direct vicinity of the lower connectors, if the device is mounted vertically with unimpeded air convection and a maximum operating height of 2000m above sea level. The cooling slots must always be free in order to ensure the proper cooling of the system.

The device can be mounted in an enclosure if the ambient temperature is taken into consideration. Provide a wall clearance of at least 50 mm on all sides of the housing, so that sufficient air circulation is ensured. A minimum clearance of 75 mm from active elements such as load current supply, transformers etc. must be ensured.

Avoid the exposure of the flat screen to direct sunlight. The radiation from the sun (UV component) reduces the lifespan of the LCD display.

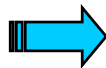

**The following must be ensured in order to prevent the device from overheating during operation:**

- **The cooling slots must always be free in order to ensure the proper cooling of the system.**
- **Avoid the exposure of the flat screen to direct sunlight.**
- **The mounting angle must not exceed  $\pm 35^\circ$  from the vertical**

**If these conditions cannot be met, the mounting of an external fan is recommended (→ Section 7.5)**

### 7.2 MOUNTING IN THE FRONT PANEL

1. Push the HPG-200 from the front into the cutout (→ Section 7.3) of the front panel.
2. The front seal must be level and evenly positioned between the front plate and the front panel.
3. Centering the device in the cutout
4. Secure the device from the rear with the supplied fixing frame. For this use the 4 securing nuts which should be tightened evenly from the rear until the front frame is flush with the front panel all round.

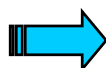

**Ensure that the seal is fitted correctly on the front panel. Avoid tightening torques of greater than 0.3 Nm as this could otherwise damage the device. The thickness of the front plate must not exceed 5 mm.**

### 7.3 FRONT PANEL CUTOUT



The device requires a mounting cutout of WxH:  
198 +0/-1 mm x 142 +0/-1 mm

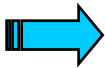

**The thickness of the front panel must not exceed 5 mm.**

**7.4 MECHANICAL DIMENSIONS**

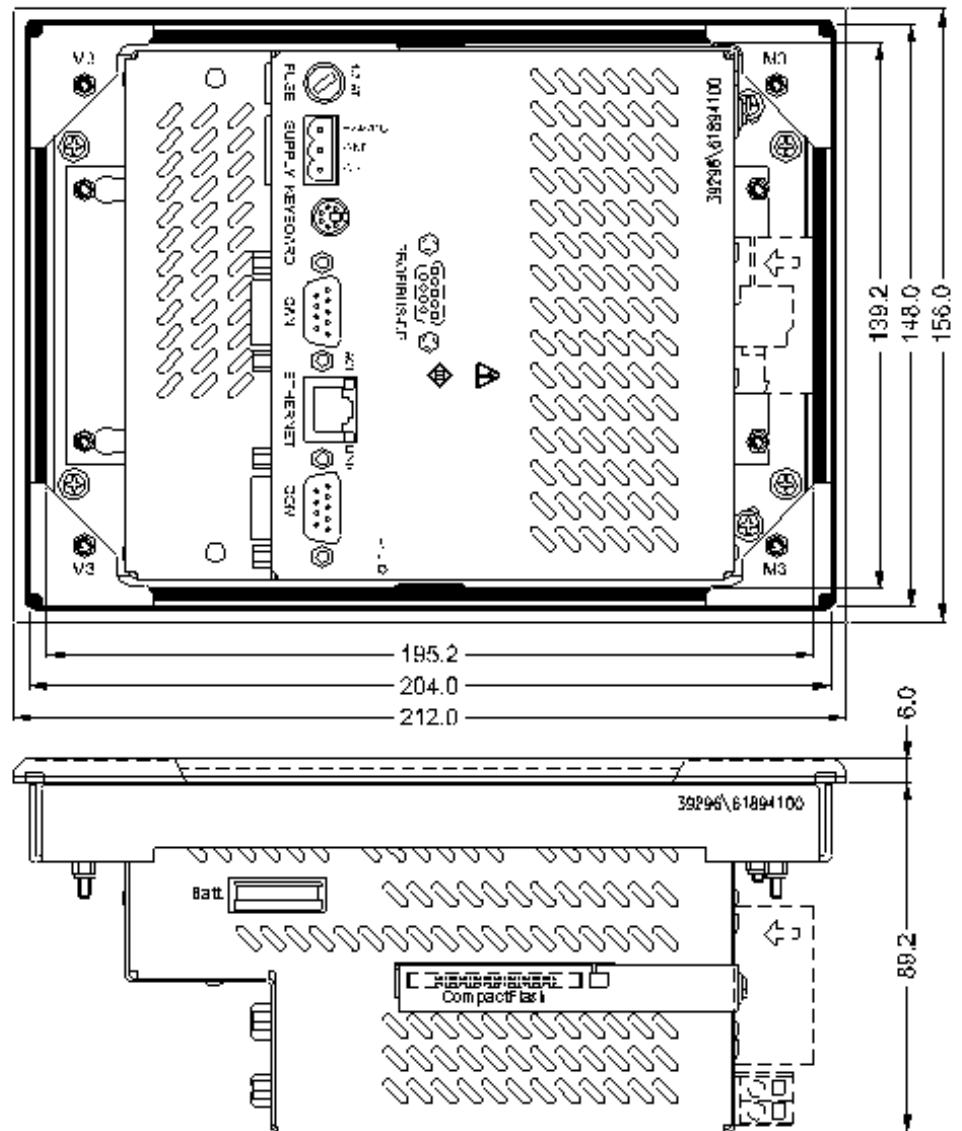

**Mounting instructions****7.5 EXTERNAL FAN**

The HPG-200 series devices are prepared for the mounting of an external fan.

**Order designations**

Fan Manufacturer Papst  
 Type Axial fan, 24V, 40x40x20mm  
 Order No. 414

**CageClamp connector**

Manufacturer WAGO-CONTACT  
 Type Male connector 2 pole  
 Ord. No. 231-632/018-000

**Screws**

Type Cylinder head screw M3x22

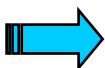
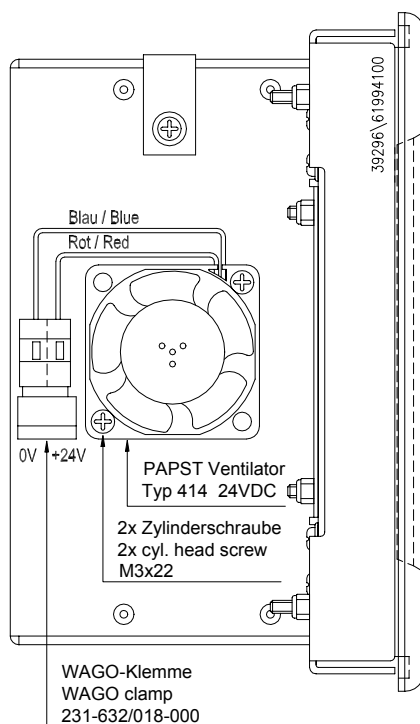

**The fan and the WAGO clamp connector can be mounted externally without having to open the housing.**

## 8 NOTES ON THE TOUCH SCREEN

### 8.1 BASIC TOUCH SCREEN FUNCTION

The touch screen operates on the active light matrix principle in the infra-red range. Interrupting this light matrix at any point will initiate an operation if a touch activated screen element was touched (e.g. a button).

A timeout is initiated if the light matrix is interrupted for longer than **approx. 15s**. The touch panel then switches to the “non-actuated” state, and further operations cannot be initiated until the initial touch actuation has stopped (e.g. button released) or the touch is actuated again. Several simultaneous touch actuations at different points cannot be evaluated.

### 8.2 POWER UP FUNCTION TEST

The HPG-200 carries out a function test of the touch screen with each power up of the device. All IR channels are tested during this stage. Faulty IR channels are indicated graphically and displayed on screen with an error message. The failure of IR channels is normally due to severe contamination of the IR transparent plastic frame which consequently has to be cleaned (➔ Section 8.3). The optical elements of the light matrix are located behind the IR transparent plastic frame in the front of the device.

IR channels that are continuously interrupted will be detected by the Touch Controller after a timeout of approx. 15s and no longer included in the evaluation. In extreme cases, this may mean that individual zones cannot be touch activated.

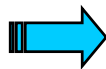

**Do not touch the screen whilst the system is being started up, and wait till your application has started. During the startup the touch screen carries out a function test.**

### 8.3 CLEANING AND MAINTENANCE OF THE TOUCH SCREEN

For operation ensure that the signal levels of the channels are not so severely reduced or interrupted due to excessive contamination through dirt (➔ Section 8.1).

Clean the inside of the plastic frame of the device regularly (➔ Section 10) with a damp soft cloth. Ensure that the surface is not scratched or scoured, especially when removing hard deposits and abrasive dust.

**Cleaning should only be carried out with the device switched off!** This will ensure that any touching of the screen will not accidentally initiate functions.

Do not expose the front of the device to solvents which may corrode and loosen the plastic frame (frame material: Makrolon 2805, Manufacturer: Bayer AG).



## 9 DISPLAY, BACKLIGHT, CONTRAST

### 9.1 CONTRAST

The contrast voltage is temperature-compensated and can be adjusted in the EPAM visualization software.

### 9.2 BACKLIGHT

The backlight has three settings (0, 50 and 100%) which can be selected in the EPAM visualization software.

## 10 DIAGNOSTICS

The following optical and acoustic diagnostic options are available:

Symptom	Possible cause and solution
Signal on power on	- Acoustic signal: - 2x short → Touch controller OK - low-low-high → Battery flat, BIOS has changed or rejected a setting
Device does not start, screen dark or error messages during startup	- - Check power supply/fuse faulty (+5V LED not lit) - Hard disk controller 1 failure → CompactFlash with MWare Runtime System HPG-200 not inserted (→ Section 5.2).
Date/time incorrect	Insert or replace battery (→ Section 5.3)
Screen dark or light	Backlight/contrast incorrectly set Reload EPAM project with Delete INI Files option
Touch not functioning	- - Hardware faulty (no acoustic signal after power on) - Too many IR channels interrupted → Clean touch
Ethernet connection faulty	- - Incorrect Ethernet cable fitted (crosslink/direct). → The LINK LED is lit when the connection is correct → The ACT LED is lit (flashing during transfer) with a correct data transfer - Incorrect/invalid IP address set → the current IP address is shown during startup at the bottom right of the screen

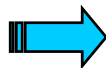

**Refer to the MWare engineering software documentation for other diagnostics options.**

---

**HPG-200**

Display PLC

Device Description HPG-200

---

Display, backlight, contrast

---

## 11 MAINTENANCE AND REPAIR

### Cleaning the screen

For trouble-free operation of the IR touch screen, clean the inner section of the device front (front glass and IR frame) regularly (➔ Section 8.3).

### Battery

The battery is used for backing up the real-time clock and the retain PLC data. The battery should be changed every 3 years in order to prevent any data loss.

Procedure for changing the battery

1. Switch on the device for at least 10 minutes
2. Then switch off the device and change the battery quickly  
(the data is retained for at least 2 minutes)

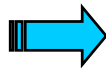

**The real-time clock must be reset after the battery is changed.**

### Repairs

Repairs to the HPG-200 should only be carried out by the manufacturer or Micro Innovation repair centers. In this case, please contact your local MSystem dealer or the Technical Support at Micro Innovation AG. (manufacturer's address ➔ Section 14)

No liability is accepted for any modifications made to the device that are not described in this document.

### Transport

Only the original packaging must be used for transporting the device.



**12 TECHNICAL DATA**

<b>Display</b>	Technology	5.7" passive STN LCD
	Resolution	320 x 240 pixels (1/4 VGA)
	Number of colors	16 greyscales/16 colors
	Display area	118 mm x 89 mm
	Backlight	1x CCFL, dimmable via software
	Contrast	Temperature-compensated, adjustable via software
	Front plate	Safety glass, non-reflective
<b>Operation</b>	Type	Infra-red touch
	Resolution	45 x 33
<b>Ambient conditions</b>	Operating climate	0...45°C, 10...90% rel. air humidity, non-condensing
	Storage climate	-20...60°C, 10...90% rel. air humidity, non-condensing
	EMC interference immunity	EN 61000-6-2
	Emission	EN 50081-2
<b>Degree of protection</b>	Front	IP 65 (NEMA 12), after EN 60529
	Rear	IP 20
<b>Weight</b>		Approx. 1.6 kg
<b>Dimensions</b>	W x H x D	212 x 156 x 89.2 mm
	Cutout	198 x 142 mm (+0/-1mm)
<b>System supply</b>	Rated voltage	24 VDC SELV, safety extra low voltage
	Voltage range	24 VDC to DIN 19240 20.4...28.8 VDC effective, absolute value with ripple 18.5...30.2 VDC 35.0 VDC for a duration of < 100ms
	Voltage dips	10 ms to EN61000-6-2
	Protection against reverse polarity	Yes
	Fuse protection	Yes
	Potential isolation	No The 0V connection is directly connected to the housing potential (GND)
	Current consumption	Normally 350mA/24VDC
	Power consumption	Normally 8.4 W/24VDC
<b>Battery backup</b>	Battery type	3V / 950mAh Lithium, RENATA CR2477N
	Data retention	Normally 5 years
<b>Real-time clock</b>	Counters	Seconds, minutes, hour, day, month, year
	Leap year change	Automatic
	DST change	Manual via the software
<b>Fuse protection</b>	Fuse	1.6 A slow
	Breaking capacity	Max. 30A
<b>Programming interface</b>	Type	Ethernet
	Connection	RJ45
<b>Interfaces:</b>		
<b>COM1</b>	Type	RS232, not isolated
	Connection	CiA, Sub-D 9-pole male
<b>CAN</b>	Type	CAN, not isolated

**Technical data**

	Connection	CiA, Sub-D 9-pole male
<b>ProfibusDP (Option)</b>	Type	Master/slave to 12MBit
	Connection	Sub-D 9 pole female
<b>Ethernet</b>	Type	10BaseT
	Connection	RJ45
<b>Keyboard</b>	Type	Standard AT (only for service tasks)
	Connection	PS2
<b>CompactFlash Slot</b>	CompactFlash Type 1	
	Technology	ATA Flash, 5V

## 13 DISPOSAL

HPG-200 devices that are no longer used must be disposed of properly or returned to the manufacturer for disposal. (manufacturer's address → Section 14)

### Special note:

- The device contains a lithium battery
- LCD units are fitted with fluorescent tubes for the backlight. These contain mercury.

### Materials:

Housing:	Galvanized sheet steel
Front/Touch frame:	Plastic Makrolon 2805 (Manufacturer: Bayer AG)
Printed-circuit board:	1. quality
Front glass:	Safety glass
Membrane:	Polyester PETP

## 14 EU CONFORMITY

The **HPG-200** meets the requirements specified by the EU Council Directives for harmonizing the regulations of EU member states relating to electromagnetic compatibility (**89/336/EEC**) and electrical safety (Low-Voltage Directive **73/23/EEC**).

The generic standards below were used to assess the electromagnetic compatibility of the HPG-200:

**EN 50081-2** (Emission)

**EN 61000-6-2** (Immunity)

The following standard was used to assess the electrical safety of the HPG-200:

**EN 60950**



Manufacturer: Micro Innovation AG

Manufacturer address: Spinnereistr. 8-14  
CH-9008 St. Gallen  
Switzerland

---

**HPG-200**  
Disposal

---

Display PLC

Device Description HPG-200

**15 REVISION HISTORY**

Revision	Date / Signed	Modifications
1.0	04-02 / Fis	First version for HPG-200
1.1	05-02 / Fis	Note on subnetwork mask Section System settings ProfibusDP to 12MB Section Features, Technical data
1.2	06-02 / Fis	Battery installed when delivered New Pictures HPG-200

**Micro Innovation AG**  
**Spinnereistr. 8-14**  
**CH-9008 St. Gallen**  
**Switzerland**

**Tel** : ++41 71 243 24 24  
**Fax** : ++41 71 243 24 90  
**email** : support@microinnovation.com  
**homepage** : www.microinnovation.com



**16 ALPHABETICAL INDEX****A**

Accessories 12  
 Ambient conditions 41  
 Application range 9

**B**

Backlight 37  
 Basic touch screen function 35  
 Battery 15, 39  
 Battery type 41

**C**

CAN 41  
 CAN connector 15, 21  
 CAN interface 21  
 Cleaning and maintenance of the touch screen 35  
 Cleaning the screen 39  
 COM1 41  
 COM1 serial interface (RS232) 24  
 Commissioning 15  
 Communication 13  
 CompactFlash 15, 42  
 Connecting the power supply 18  
 Connecting the programming interface 20  
 Connection for keyboard 24  
 Contents 5  
 Contrast 37  
 Copyright 2  
 Cycle time 13

**D**

Danger warnings 7  
 Degree of protection 41  
 Designing 12  
 Device versions 11  
 Diagnostics 37  
 Dimensions 41  
 Display 13, 41  
 Display, backlight, contrast 37  
 Disposal 43

**E**

**Email** 45  
 Ethernet 15, 42  
 EU Conformity 43  
 Exchangeable memory 13  
 Explanation of symbols 7

**F**

Fax 45  
 Features 13  
 Front plate versions 11  
 Fuse 15  
 Fuse protection 41

Subject to technical modifications  
 Doc No. 92 24 000000 (06/2002)  
 © by Micro Innovation AG

**H**

Homepage 45

**I**

Inserting the battery 17  
 Inserting the CompactFlash 16  
 Introduction 9

**K**

Keyboard 15, 42

**M**

Maintenance and repair 39  
 Manufacturer 43  
 Manufacturer address: 43  
 Minimum clearance 31

**N**

Notes on the touch screen 35

**O**

Operation 25  
 Overview of connections 15

**P**

PLC operating states 26  
   Power on 26  
   Run 26  
   Stop 26  
   System fault 26  
 Power supply 15  
 Power up function test 35  
 Preparing the shield connections 19  
 ProfibusDP 42  
 ProfibusDP master interface 24  
 Program transfer 28  
 Programming cable 12  
 Proper use 3

**R**

Real-time clock 41  
 Repairs 39  
 Reset 27  
 Reset Cold 27  
 Reset Original 27  
 Revision history 45  
 RS232 15

**S**

Safety instructions for the user 4  
 Shutdown behaviour 25  
 Spare battery 12

Start 27  
Start messages 25  
Startup behaviour 25  
Startup behaviour/startup 28  
System supply 41

**T**

Technical data 41  
Telefon 45  
Touch 13

Transport 39

**V**

Visualization 13

**W**

Warnings 7  
Weight 41