

Software Manual

# *Cam Designer Basic*



This Manual is valid for the **Cam Designer Basic** from version 2.3

### **Copyright**

© 2005 Lenze Drive Systems GmbH. All rights reserved.

### **Imprint**

Lenze Drive Systems GmbH

POB 10 13 52, 31763 Hameln, Germany

Phone: ++49 (0)5154 / 82-0

Fax: ++49 (0)5154 / 82-2111

E-mail: Lenze@Lenze.de

### **Copyright information**

All texts, photos and graphics contained in this documentation are subject to copyright protection. No part of this documentation may be copied or made available to third parties without the explicit written approval of Lenze Drive Systems GmbH.

### **Liability**

All information given in this documentation has been selected carefully and tested for compliance with the described hardware and software. Nevertheless, discrepancies cannot be ruled out. We do not accept any responsibility or liability for any damage that may occur. Required corrections will be included in updates of this documentation.

### **Trademarks**

Microsoft, Windows and Windows NT are either registered trademarks or trademarks of Microsoft Corporation in the U.S.A. and/or other countries.

Adobe and Reader are either registered trademarks or trademarks of Adobe Systems Incorporated in the U.S.A. and/or other countries.

All other product names contained in this documentation are trademarks of the corresponding owners.

## Contents

<b>1</b>	<b>About this Manual</b> .....	<b>5</b>
1.1	Conventions used .....	5
1.2	Layout of the safety information .....	6
<b>2</b>	<b>System requirements</b> .....	<b>7</b>
2.1	Connection with the target system .....	7
<b>3</b>	<b>Software installation</b> .....	<b>8</b>
<b>4</b>	<b>Introduction</b> .....	<b>9</b>
4.1	Motion tasks .....	12
4.2	Scaled motion rules.....	13
<b>5</b>	<b>User interface</b> .....	<b>14</b>
5.1	Using the direct help.....	14
5.2	Language selection .....	15
5.3	Title bar.....	15
5.4	Menu bar .....	15
5.5	Toolbar .....	16
5.6	Project structure.....	17
5.7	Screen divider .....	18
5.8	Workspace .....	18
5.9	Output area .....	18
5.10	Status bar.....	19
5.11	Document window (worksheet) .....	20
<b>6</b>	<b>Operation</b> .....	<b>21</b>
6.1	Create a new project .....	22
6.1.1	Step 1: Defining the features of the master axes.....	22
6.1.2	Step 2: Defining the properties of the slave axis .....	24
6.1.3	Step 3: Set profile options .....	27
6.1.4	Step 4: Defining the file name and directory for a project.....	29
6.1.5	Step 5: Adding a slave axis.....	29
6.1.6	Creating further products .....	32
6.2	Open an existing project .....	34
6.2.1	Selecting the properties of a slave.....	34
6.2.2	Deleting a slave.....	35
6.3	Connection with the OPC server.....	36
6.4	Downloading the drive data.....	36

**Cam Designer Basic**

## Contents

6.5	Saving the project .....	37
6.6	Saving a project under another name .....	37
6.7	Exiting Cam Designer Basic .....	38
<b>7</b>	<b>Functions.</b> .....	<b>39</b>
7.1	Working with the worksheet .....	39
7.2	Settings for the worksheet .....	39
7.3	Object Input Mode .....	39
7.4	Interpolation mode .....	40
7.5	Worksteps required for a new cam .....	40
7.6	Settings of the worksheet .....	41
7.7	Creation of profiles .....	41
7.8	Closed profile .....	43
7.9	The cam group .....	46
7.9.1	Defining the cam type and cam reference .....	46
7.9.2	Cam types .....	47
7.10	Export of profile data .....	48
7.11	Cam Designer Basic Online Download .....	49
<b>8</b>	<b>Appendix.</b> .....	<b>50</b>
8.1	Error numbers, causes & remedies .....	50
8.2	Glossary .....	51
<b>9</b>	<b>Index</b> .....	<b>53</b>

## 1 About this Manual

This Manual contains information about **Lenze Cam Designer Basic**.



The »Cam Designer Basic« is a software which is used to transfer recipes consisting of motion profiles, cam tracks and position markers from a PC to Lenze target systems.

Special features of the »Cam Designer Basic« are:

- ▶ Import of CAD data via standardised interfaces (VDI 2143).
- ▶ Program operation via an easy-to-use PC user interface for the first commissioning and the preparation of additional functions to be provided to the final user by the mechanical engineer.
- ▶ Smoothing of imported CAD data (motion profiles) for a smoother running of the drives.

### 1.1 Conventions used

This Manual uses the following conventions to distinguish between different types of information:

Type of information	Marking	Examples/notes
Variable identifier	<i>italic</i>	Set <i>bEnable</i> to TRUE to...
Window		The <i>message window...</i> / The <i>Options</i> dialog box...
Control element	<b>bold</b>	The <b>OK</b> button... / The <b>Copy</b> command... / The <b>Properties</b> tab... / The <b>Name</b> input field...
Sequence of menu commands		If the execution of a function requires several commands, the individual commands are separated by an arrow: Select <b>File</b> → <b>Open</b> to...
Keyboard command	< <b>bold</b> >	Use < <b>F1</b> > to call the Online Help. If a command requires a combination of keys, a "+" is placed between the key symbols: Use < <b>Shift</b> >+< <b>ESC</b> > to...
Program listings	Courier	<b>IF</b> var1 < var2 <b>THEN</b> a = a + 1 <b>END IF</b>
Keyword	<b>Courier bold</b>	
Link	<u>underlined</u>	Links are highlighted references which are activated by means of a mouse click.
Safety information		▶ <a href="#">Layout of the safety information</a> (📖 6)
Step-by-step instructions		Like safety information, step-by-step instructions and tips can be recognised by an icon.
Tip		

# Cam Designer Basic

About this Manual

Layout of the safety information

## 1.2 Layout of the safety information

All safety information have a uniform structure:

- ▶ The icon characterises the type of danger.
- ▶ The signal word characterises the severity of danger.
- ▶ The note describes the danger and suggests how to avoid the danger.



### Signal word

Note

Icon	Signal word	Meaning	Consequences if disregarded
 hazardous electrical voltage	<b>Danger!</b>	Impending danger to persons	Death or severe injuries
 general danger			
	<b>Stop!</b>	Potential damage to material	Damage to the controller or its environment
	<b>Note!</b>	Note	

## 2 System requirements

The following minimum requirements on hardware and software must be met to use the »Cam Designer Basic«.

- ▶ Microsoft® Windows® 98, Windows NT® 4.0 (as of Service Pack 5), Windows® 2000 (as of Service Pack 2) or Windows® XP.
- ▶ 64 MByte RAM  
128 MByte RAM (Windows® XP/2000)
- ▶ IBM compatible PC (CPU: Pentium 90 MHz processor or faster)
- ▶ Super VGA screen
- ▶ Hard disk with at least 120 MB of free disk space
- ▶ CD-ROM drive
- ▶ Mouse (Microsoft-compatible)

### 2.1 Connection with the target system

The communication with the target system (controller, Servo PLC or 9300EK servo cam) requires a fieldbus-specific interface module for the PC and the corresponding fieldbus modules for the target systems to be connected.

For system bus (CAN) communication, Lenze offers the following components as interface module for the PC:

Bus system		Max. number of target systems	
	PC port		Required hardware components
System bus (CANopen)		63	
	Parallel port (LPT port)		PC system bus adapter 2173 incl. connection cable and voltage-supply adapter <ul style="list-style-type: none"> <li>• for DIN keyboard connection (EMF2173IB)</li> <li>• for PS/2 keyboard connection (EMF2173IBV002)</li> <li>• for PS/2 keyboard connection with electrical isolation (EMF2173IBV003)</li> </ul>
	USB (Universal Serial Bus)		PC system bus adapter 2177 incl. connection cable (EMF2177IB)

### 3 Software installation



#### How to install the »Cam Designer Basic«:

1. Start Windows.
2. Insert the CD-ROM »Cam Designer Basic« into the CD-ROM drive.
  - If the auto-start function of the CD-ROM drive is active, the installation program is started automatically and you can proceed with step 5.
3. Select Run ... from the start menu.
4. Enter the letter for your CD-ROM drive followed by ":\setup.exe" (e.g. "e:\setup.exe") in the command line and confirm with OK.
5. Follow the instructions of the installation program.



#### Note!

Installation under Windows NT/2000/XP requires administrator rights!

## 4 Introduction

»Cam Designer Basic« is a graphic tool for the easy creation of electronic cams.

»Cam Designer Basic« provides the features of the »Cam Designer Professional« in reduced form.

### Main features of the »Cam Designer Basic«

- ▶ Easy creation of cams by means of graphic objects (e.g. lines, polynomials).
- ▶ Data is directly input using the physical unit.
- ▶ Display of speed, acceleration torque and jerk.
- ▶ Printing of the cam graphics with project information and date.

### Main features of the Software Package - Cam

- ▶ 48 profiles can be stored in the PLC
- ▶ 289 base points per profile in the relative data model
- ▶ 116 base points per profile the absolute data model
- ▶ Increased number of the available base points with reduced number of profiles reserved
- ▶ 48 cam groups can be stored
- ▶ Three tracks per cam group
- ▶ Four cams per tracks

### Main features of the 9300EK servo cam

- ▶ 8 profiles can be stored in the PLC
- ▶ 256 base points per profile in the relative data model
- ▶ 64 base points per profile the absolute data model



#### Note!

No names are used for profiles and projects in the documentation. The examples use the names assigned by the system. You can assign names on your own in your system.

The »Cam Designer Basic« is a product of the Software Package - Cam. It manages the relevant data of the machine and also creates projects. However, it lacks the »Cam Manager« and hence the ability of managing several products at the same time.

**Entries via the »Cam Designer Basic«**

- ▶ The project
  - Only one product at a time is available, i.e. only one product at a time can be processed.
  - Machine structure
  - Names of the axes
- ▶ The feed constant and gearbox factor of each axis
- ▶ Scaling of the axes for profile creation
- ▶ The master axis
  - Number of cycles of the machine
    - The value is a rated value and can maximally amount to 199% during operation.
- ▶ The slave axes
  - Number of profiles to be stored
  - Number of base points to be assigned
  - Selection of the data model
- ▶ The product (profiles)
  - Product name
  - Product number

**Note!**

No names are used for projects and products. The names given by the »Cam Designer Basic« are continued to be used. You are able to select the names on your own in your project.

**Advantages of »Cam Manager«**

the »Cam Manager« is not included in the »Cam Designer Basic«.

The management of projects with several products and the corresponding axes using the »Cam Designer Basic« is only possible with a directory structure.

The »Cam Designer Professional« manages the projects using the integrated »Cam Manager«.

The assignment between products and axes is displayed in the »Cam Manager«.

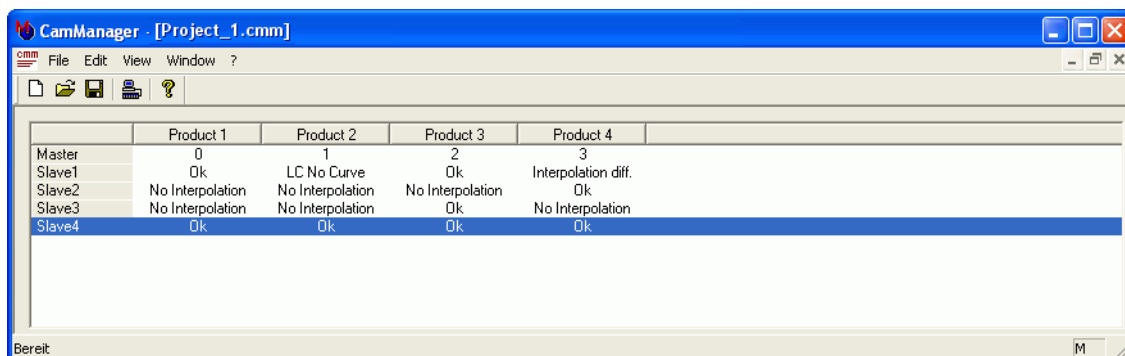

- ▶ The products and axes are stored and managed automatically in the »Cam Designer Professional«.
- ▶ The storage and management of the products and axes in the »Cam Designer Basic« are provided by means of the \*.LCx-files and \*.cam-files
  - LC9 for Servo PLC and ECS EA
  - LC7 for 9300 EK servo cam

Name	Size	Attributes	Type	Date Modified
Noname2.cam	6 KB	A	CamDesign Document	23.08.2005 14:32
Product 1.cam	6 KB	A	CamDesign Document	16.08.2005 15:39
Product 2.cam	6 KB	A	CamDesign Document	16.08.2005 14:54
Slave1.lc7	4 KB	A	LC7 File	10.08.2005 11:31
Slave1.lc9	64 KB	A	LC9 File	16.08.2005 12:25

# Cam Designer Basic

## Introduction

### Motion tasks

#### 4.1 Motion tasks

According to the VDI 2143 with the title "Motion rules for cam mechanisms" the motion tasks can be classified as follows:

Motion task	Abbreviation	Speed in the boundary point	Acceleration in the boundary point	Graphical representation
Break	R	$v = 0$	$a = 0$	Line
Constant speed	G	$v \neq 0$	$a = 0$	Line
Reversal	U	$v = 0$	$a \neq 0$	Point
Motion	B	$v \neq 0$	$a \neq 0$	Point

These four motion tasks serve to formulate the technological specifications for all problems relevant to practice.

For calculating the profile segments between the defined sections, the boundary values of the specifications are required.

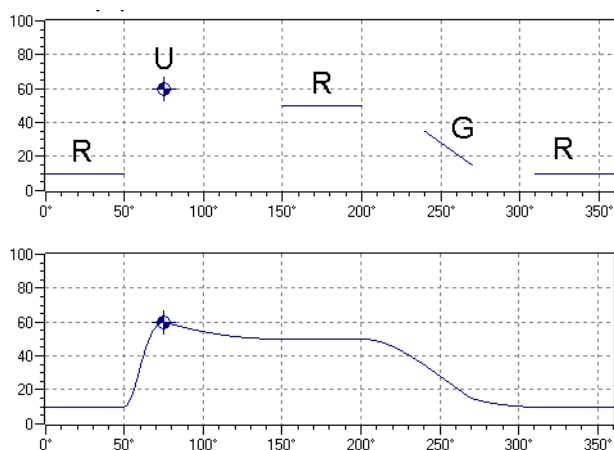

- ▶ Since the acceleration for R and G is  $= 0$ , these two motion tasks can be described linearly. The boundary values on the left and right connection are identical in this case.
- ▶ The acceleration for U and B is  $\neq 0$ . These elements can be represented as a point on the worksheet.

After entering these basic elements for the motion tasks and determining the required boundary values, the connections can be entered according to the motion rules. Depending on the connection type used, a jerk-free motion can be achieved.

## 4.2 Scaled motion rules

Each segment  $i$  of the whole cam describes a part which is defined by the value range  $s_{i0} = f(j_{i0})$  and  $s_{i1} = f(j_{i1})$ .

- ▶ The corresponding functions are imaged internally to the scaled value range of 0...1.
- ▶ The coefficients of the profiles, included in the property pages, also refer to this scaled value range.
- ▶ The speeds and accelerations in the property page represent the real boundary value with regard to the geometrical dimensions. Thus, the calculation is based on the rule  $v = ds / dj$  and  $a = d^2s / dj^2$ .

These geometrical values for speed and acceleration are also used in the graphical representation.

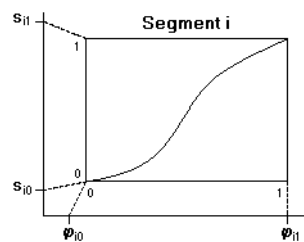

# Cam Designer Basic

User interface

Using the direct help

## 5 User interface



Go to the *Start menu* and select **Programs→Lenze→Global Drive Cam Designer Basic** to start the »Cam Designer Basic« with user interface.

The user interface contains the following control and function elements:

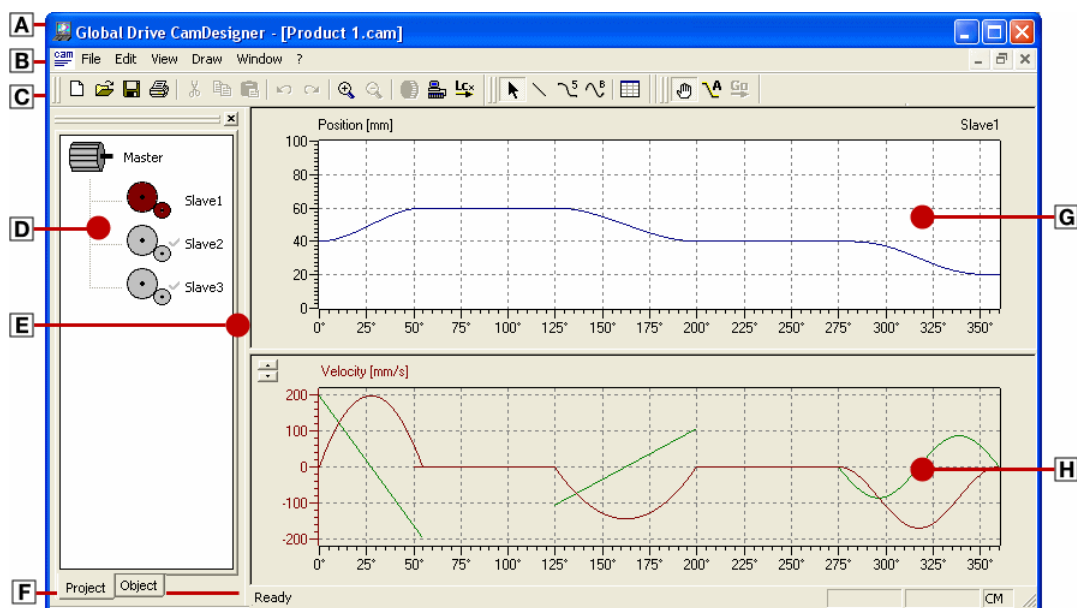

**A** [Title bar](#)

**C** [Toolbar](#)

**E** [Screen divider](#)

**G** [Workspace](#)

**B** [Menu bar](#)

**D** [Project structure](#)

**F** [Status bar](#)

**H** [Output area](#)

### 5.1 Using the direct help

The »Cam Designer Basic« has a direct help which can be used to display information about specific areas of the user interface.



Select the command **Help→Direct help** and click the area about which you want to obtain more detailed information.

If you have opened e.g. the dialog box *Project settings* and click the input field **Rated quantity cycle/min**, information about this dialog object is displayed when pressing <F1>.

## 5.2 Language selection

You can always select another language for the menu, dialog and help texts of the »Cam Designer Basic«.

- ▶ The available languages depend on the language files that have been installed together with the »Cam Designer Basic«.









### How to select another language...

1. Select command **View→Set language**.
2. Go to the *Language configuration* dialog box and select the desired language.
3. Click **OK** to confirm your selection and close the dialog box.

## 5.3 Title bar

The *title bar* at the top of the application window shows the **program icon** and the **program name** on the left and the **window icons** on the right.

- ▶ With a click on the **Window icons**    you can change the representation of the application window as follows:
  - Icon in the *task bar* ()
  - Full screen ()
  - Window size ()
- ▶ A click on the **program icon** opens the **system menu** which also includes commands for positioning and changing the size of the application window.
- ▶ A click on the **window icon**  or a double-click on the **program icon** exits the »Cam Designer Basic«

## 5.4 Menu bar

Via this *menu bar* you have access to all menu commands of the »Cam Designer Basic«. In contrast to the »Cam Designer Professional« the profile functions are reduced.

- ▶ A click on an item of the main menu opens the corresponding menu and lists the menu items contained in it.
- ▶ Click a menu item to execute the corresponding function.
  - Menu items which are displayed in light grey are currently deactivated because the execution of the corresponding function would not make any sense in the current program state.



### Tip!

Many frequently used functions can be executed faster by means of the [Toolbar](#) icons. ([16](#))

# Cam Designer Basic

User interface



Toolbar



## 5.5 Toolbar

The display is optional.

Via the icons of the *toolbar* you can easily execute some of the most frequently used menu commands without making a detour via the [Menu bar](#). The selection of the available functions depends on the active mode/window.

- Simply click an icon to activate the corresponding command.

Icon	Menu command	Function
	File→New	Creates a new Cam Designer Basic project.
	File→Open	Opens a Cam Designer Basic project.
	File→Save	Saves the project under the current name.
	File→Print	Prints the project.
	Edit→Cut	Deletes a selected object and moves it to the clipboard.
	Edit→Copy	Copies a selected object and moves it to the clipboard.
	Edit→Paste	Pastes a copied or cut object into the current position.
	Edit→Undo	Undoes the last action.
	Edit→Redo	Redoes the last undone action.
	View→Zoom In	Enlarges the worksheet view.
	View→Complete View	Resets the worksheet view to standard size.
	Edit→Acceleration Dimensioning	Opens the acceleration dimensioning dialog.
	File→Connect to OPC Server	Establishes a connection to the OPC server.
	File→Create LCx-file and Download	Opens a dialog for selecting a drive.
	Draw→Select	Selects the drawing objects.
	Draw→Line	Draws a line.
	Draw→Polynomial (5.)	Draws a 5th grade polynomial.
	Draw→Sloped Sine	Draws a sloped sine function (Bestehorn).
	Draw→Table	Draws a table.
	View→Object Input Mode	Input of motion objects.

Icon	Menu command	Function
	View→Interpolation mode	Changes to the interpolation mode.
	Edit→Start Calculation	Connects the profile segments.

**Tip!**

If you move the mouse pointer over an icon, a tool tip pops up providing a short information on the corresponding function. Moreover, an additional information is displayed in the [Status bar](#).

## 5.6 Project structure

The display is optional.

The project structure consists of the tabs **Project** and **Object**.

### Project

In this tab the master axis and the created slave axes are displayed.

- ▶ A double-click on the icon activates the corresponding slave axis. The associated profiles are displayed accordingly.
- ▶ A mouse-click highlights the name of the master or slave axis in blue. When clicking the blue field, the name can be changed.

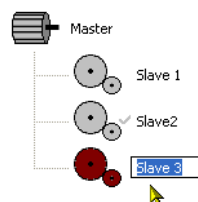

## Cam Designer Basic

User interface

Screen divider

### Object

This tab shows the list of all objects in the active mode. Optionally, the objects of the lower levels, highlighted in grey, can also be shown.

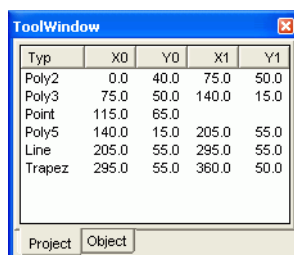

Typ	X0	Y0	X1	Y1
Poly2	0.0	40.0	75.0	50.0
Poly3	75.0	50.0	140.0	15.0
Point	115.0	65.0		
Poly5	140.0	15.0	205.0	55.0
Line	205.0	55.0	295.0	55.0
Trapez	295.0	55.0	360.0	50.0

- ▶ Each line in the list contains the object type and coordinates of the object. The lines are sorted according to the X values (master) as standard. A different sort sequence can be achieved by a mouse-click on the fields in the headline.
- ▶ It is possible to select one or several objects in the list by means of the mouse. The selection is also transferred to the graph of the worksheet.
- ▶ A click with the right mouse button on the corresponding object opens a submenu which contains various functions. The property dialogs of the objects can be opened, the object can be copied or deleted.

In the **Objects** tab, the lines, profiles etc. can be edited.

### 5.7 Screen divider

The screen divider is the border between two non-overlapping windows. In the »Cam Designer Basic« there is a screen divider between the worksheet, time derivations and the object list.

### 5.8 Workspace

The document windows (worksheets) are displayed in the workspace.

- ▶ When the »Cam Designer Basic« is started, the workspace is blank because there are no open projects.
- ▶ The worksheet is the area for entering and editing graphic objects.

### 5.9 Output area

The display is optional.

- ▶ This diagram displays the time derivations of the objects from the worksheet.
- ▶ In this diagram, the cams of the individual tracks for the target systems **Servo PLC** and **ECS EA** can be created and edited.

## 5.10 Status bar

The display is optional.

The program status is indicated in the *status bar*.

The status bar describes the action which is executed by the menu item selected or a pressed button of the toolbar and displays the coordinates of the mouse pointer.



### Tip!

If you position the mouse pointer over an icon in the [Toolbar](#) or a menu command, more information about the corresponding function will be indicated in the *status bar*.

## Cam Designer Basic







User interface

Document window (worksheet)

### 5.11 Document window (worksheet)

If you open a project, the corresponding *worksheet* will be indicated in a *document window* in the [Workspace](#) of the Cam Designer Basic.

By default, the *document window* is displayed on a full screen, i.e. the *document window* fills the whole *workspace* of the »Cam Designer Basic«.

- ▶ With a click on the **window icons**    at the top right of the *document window* you can change the representation of the *document window* as follows:
  - Icon within the *workspace* ()
  - Full screen ()
  - Window size ()
- ▶ A click on the **program icon** opens the **system menu** which also includes commands for the positioning and size of the *document window*.
- ▶ A click on the **window icon**  or a double-click on the **program icon** closes the *document window*.
- ▶ Use the key combination **<Ctrl>+<F6>** to jump from one *document window* to the next *document window*.

#### "Window" menu

The **Window** menu contains the following commands for the arrangement of the *document window*:

Command	Function
<b>New window</b>	Opens a new window with the same contents as the active window. In this way, it is possible to display different parts or views of a worksheet simultaneously. <ul style="list-style-type: none"> <li>• The new window will be automatically the active window and will be indicated above all other open windows.</li> <li>• If the contents of an open window is changed the contents of all other open windows of the project change as well.</li> </ul>
<b>Cascade</b>	Cascades all windows in the workspace.
<b>Horizontal</b>	Arranges all windows in the workspace horizontally.
<b>Arrange icons</b>	Arranges all windows reduced to an icon at the bottom of the workspace. <ul style="list-style-type: none"> <li>• If a window opens in this section, it may happen that one or all icons are hidden because they are under the window.</li> </ul>
<b>1, 2, 3...</b>	All open windows are listed at the end of the <b>Window</b> menu. A click on an entry activates the corresponding window (and places it on top of the desktop). <ul style="list-style-type: none"> <li>• The active window is indicated by a hook in front of the entry.</li> </ul>

## 6 Operation

After the first start of »Cam Designer Basic« the user interface is displayed with an empty workspace.

- ▶ Now you can create a new project (worksheet) or open an existing project.



### Tip!

In the installation directory of the »Cam Designer Basic« you can find example projects which can be used to make yourself familiar with the operation of the »Cam Designer Basic«.

### What do you want to do?

- ▶ [Create a new project](#) (📖 22)
- ▶ [Open an existing project](#) (📖 34)

## Cam Designer Basic

Operation

Create a new project

### 6.1 Create a new project

After starting the »Cam Designer Basic« the user interface is displayed with the master axis and a slave axis. You can either continue to process the project or call a new project.



#### How to create a new project...

Go to the *symbol bar* of the »Cam Designer Basic« and click the symbol  or select **File→New** to start a new project:

Detailed information about the individual steps can be found in the following subsections.

#### 6.1.1 Step 1: Defining the features of the master axes

The entries in the axes reflect the machine constants. Therefore, only work with real values.

► The master axis can be a real or virtual axis.



#### Note!

If you only use a virtual master, then enter in the group field **Machine** under **Gearbox factor** in the input field **z2** 100 and in **z1** 1. This serves to achieve a higher resolution of the master angle.

The master axis has the features of an **electrical shaft**.

The following overview shows the relevant global data for the **electrical shaft** function. Signal flow between the template functions for the **Electrical shaft**.

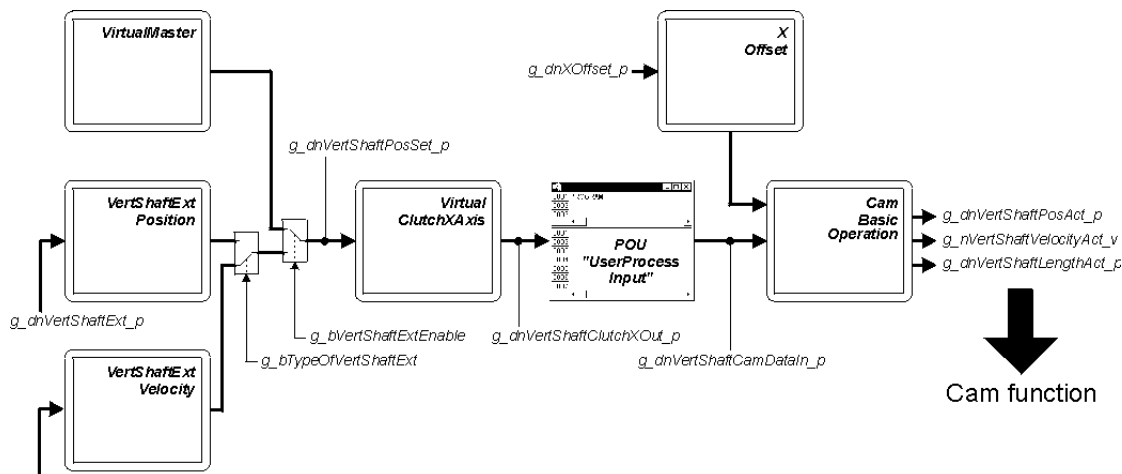

► Enter the indicated values into the dialog box *Master* ein.

Dialog object	Description
Input field <b>Name</b>	Name of the master axis
Input field <b>Minimum</b>	In the dialog box <i>Master</i> the 0.0000 must always be entered here.
Combination field <b>Unit *</b>	The unit used
Input field <b>Maximum *</b>	Cycle <ul style="list-style-type: none"> <li>An electrical shaft can be divided e.g. from 0° to 360° or from 0 to 100mm.</li> <li>In this case, one master cycle amounts to 360° or 100mm</li> </ul>
Input field <b>Cycles/min</b>	Production cycles in 1/min The value can maximally amount to 199%. <ul style="list-style-type: none"> <li>The machine speed which you want to reach with this profile can be set in the input field <b>Cycles/min</b>.</li> <li>Serves the display <ul style="list-style-type: none"> <li>–to dimension the acceleration</li> <li>–of the time cams of the cam group.</li> </ul> </li> </ul>
Input field <b>Rated cycles/min</b>	Production cycles in 1/min The nominal value can maximally amount to 199%. <ul style="list-style-type: none"> <li>The maximum possible machine speed can be entered in the input field <b>Rated quantity cycle/min</b>. This entry is important for the acceleration precontrol. (Servo PLC / servo cam 9300EK)</li> </ul>
Input field <b>Gear factors z2/z1 *</b>	Ratio of an upstream gearbox. (e.g. 100/1 as real value)
Input field <b>Feed constant *</b>	Path per revolution at the output end of the gearbox (if an angle is stated, one revolution = 360°) The physical unit entered is converted to the encoders. <ul style="list-style-type: none"> <li>Enter, for instance, the leadscrew pitch.</li> <li>When entering increments, enter the number of increments per revolution.</li> </ul>

Fields must be filled with \* !

## Cam Designer Basic

Operation

Create a new project



### Note!

If you use a virtual master, enter in the group field "Machine" under "Gearbox factor" 100 in the input field z2 and 1 in the input field z1. This serves to achieve a higher resolution of the master angle.



### How to define the properties of the master...

1. Go to the *Master* dialog box and select the properties of the master.
  - The **Name** of the master is indicated on your worksheet.
  - The **Cycles** are the maximum number of operating cycles per minute.
2. Click **Next** to proceed with the next step.

### 6.1.2 Step 2: Defining the properties of the slave axis

The entries in the axes reflect the machine constants. Therefore, only work with real values.

- ▶ Enter the indicated values into the dialog box *Slave*.

Dialog object	Description
Input field <b>Name</b>	<ul style="list-style-type: none"> <li>The slave axis must have a definite name (e.g. Slave1) and must not be used for other slaves at the same time.</li> <li>The name of the slave axis is used by the CamDesigner. CamDesigner creates a Slave1.LC9 or Slave1.LC7.</li> </ul> <p>In this *.LC9-file or *.LC7-file all profile data, cams and position marker are stored.</p>
Input field <b>Minimum</b> *	Set range of motion
Input field <b>Maximum</b> *	
Combination field <b>Unit</b> *	Selection of the unit
Control field <b>Absolute data model</b> <b>Relative data model</b>	<p>When using the absolute data model, you have internal or external (PC) access to each single base point. However, a fewer number of base points is available then.</p> <ul style="list-style-type: none"> <li>If the control field <b>Absolute data model</b> is not marked, the relative data model is used. When using the relative data model, more base points are available. The base points are distributed automatically.</li> <li>If the relative data model is used, the entire profile can only be accessed with the Cam Designer Basic/Professional or Cam Loader to change profile data. The profile data cannot be changed via access from a PLC.</li> </ul>
Input field <b>Curves</b> *	<p>Maximum number of the curve profile to be stored.</p> <p>Reserves should be considered in the maximum number of curve profiles.</p>
Input field <b>Points</b> *	<p>Number of base points</p> <p>Maximally 1 base point/ms or less</p>
Group field <b>Background layout</b>	<p>Curves are distinguished by colour.</p> <p>Improved representation of the curves in multi-axis applications.</p>
Input field <b>Gearbox factors z2/z1</b> *	<p>Ratio between motor and tool</p> <p>Example: multi-stage gearbox</p> <p>Gearbox numerator = <math>z2 \times z4 = 28 \times 32 = 896</math> (value of z2)</p> <p>Gearbox denominator = <math>z1 \times z3 = 23 \times 15 = 359</math> (value of z1)</p>
Input field <b>Feed constant</b> *	<p>Path per revolution at the output end of the gearbox.</p> <p>(If an angle is stated, one revolution = 360°)</p> <p>The physical unit entered is converted to the encoders.</p> <ul style="list-style-type: none"> <li>Enter, for instance, the leadscrew pitch.</li> <li>When entering increments, enter the number of increments per revolution.</li> </ul>
Group field <b>Data of drive controller</b>	<p>The selection field <b>Type</b> serves to select a target system.</p> <ul style="list-style-type: none"> <li>Servo PLC/ECS servo system</li> <li>9300 EK (9300 servo cam)</li> </ul> <p>The input field <b>GDC file</b> serves to import a GDC file.</p> <ul style="list-style-type: none"> <li>Only if 9300 EK (9300 servo cam) has been selected.</li> </ul> <p>Assignment of a drive via the bus address.</p> <p>Shows the path of the selected drive.</p> <p>The button ... serves to select a drive.</p> <ul style="list-style-type: none"> <li>The assignment is only necessary if profiles, cams etc. are to be changed.</li> <li>To change profiles, cams etc. online, all drives must be online.</li> </ul>
Fields must be filled with * !	

## Cam Designer Basic

Operation

Create a new project

- ▶ The **name** of the slave axis is shown in the worksheet and also used for the LCx-file. Moreover, a subdirectory with this name is created in the project directory.
- ▶ When selecting the **Type** "9300 EK (9300 servo cam profiler)" you can optionally indicate the corresponding **GDC file**. The **Gear factors** and the **Feed constant** will then be automatically read from this file.

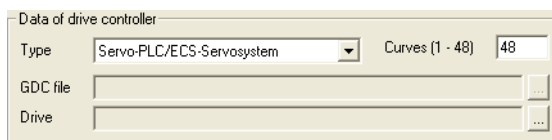

- ▶ If you have an online connection you can use the  button after the **Drive** input field to assign a drive to the slave axis.

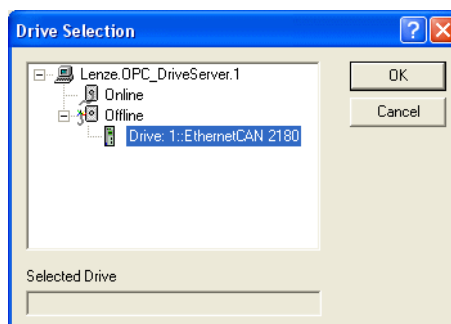

- ▶ The selections under **Absolute data model** and **Curve** have a direct influence on the maximum number of points. If you need more points for the table of points deactivate the selection **Absolute data model** and use the relative data model or reduce the value under **Curve**.
- ▶ The maximum Curve depends on the selected type.



### How to define the properties of the slave...

1. Go to the *Slave* dialog box to select the properties of the slave axis.
2. Click **Next** to proceed with the next step.

### 6.1.3 Step 3: Set profile options

The *General* dialog box can be accepted as shown.

When using the menu command **Edit→Project Settings...** the *Settings* dialog box is displayed. In the dialog box the project settings can be changed afterwards.

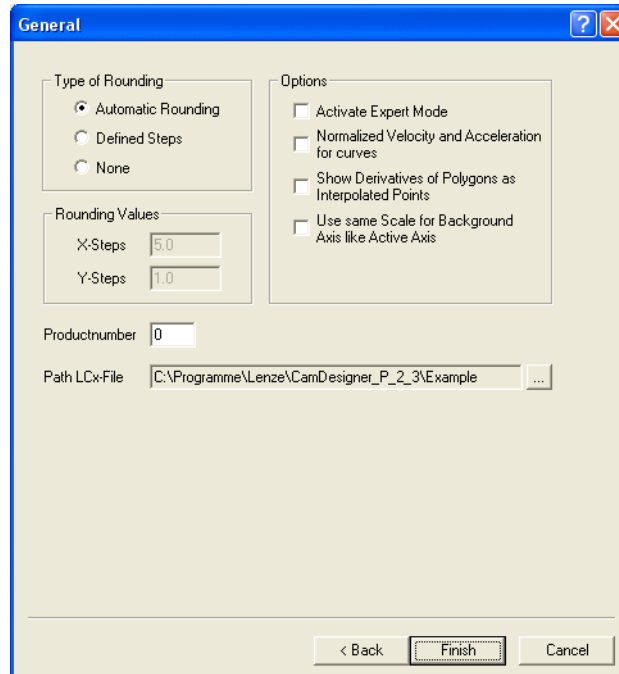

- ▶ Enter the indicated values into the dialog box General ein.

## Cam Designer Basic

Operation

Create a new project

Dialog object	Description
Option field <b>Automatic rounding</b>	All position values of the master(X) and slave(Y) are automatically rounded to suitable values.
Option field <b>Defined steps</b>	The position values of master and slave are rounded to a multiple of the defined increments <b>X steps/Y steps</b> .
Option field <b>None</b>	The position values are not rounded.
Input field <b>X steps</b>	Value for <b>Defined steps</b> The position values of the master are rounded to a multiple of the value entered.
Input field <b>Y steps</b>	Value for <b>Defined steps</b> The position values of the slave are rounded to a multiple of the value entered.
Control field <b>Activate Expert Mode</b>	Values of the profile objects <b>Sloped Sine (Bestehorn)</b> and <b>Polynomials</b> can be modified.
Control field <b>Normalized Velocity and Acceleration for curves</b>	Scaled display of the derivations.
Control field <b>Show Derivatives of Polygons as Interpolated Points</b>	In the linear interpolation, the speed is mathematically indicated as staircase and the acceleration as pulse.
Control field <b>Use same Scale for Background Axis like Active Axis</b>	The axes in the background are indicated with the same scaling as the axis in the foreground. This enables the profiles to be compared directly.
Input field <b>Product number</b>	Number of the product. The index of the profile data is integrated in the structure of the controller.
Input field <b>Path LCx-file</b>	Display of the index for storing the LCx-files.

- ▶ In the input field **Product number** a numerical value can be entered for the profile to be processed.
  - Servo PLC, 0 to 47
  - 9300EK servo cam, 0 to 7
- ▶ Press the button  to open the path in which the files (LCx-files) are stored.

For the download via DDS or Global Drive Loader the files can be loaded from the directory.



### Note!

Information on the single menu items can be found in the Online Help.

Make sure that the product numbers are not assigned twice and the correct path has been selected for the LCx-file.

If the project is stored with **Save as...**, it should be stored in the same directory as the LCx-files.

After the basic settings have been selected by means of the wizard, you can add more slaves to your project if required for your drive application.

#### 6.1.4 Step 4: Defining the file name and directory for a project



##### Tip!

We recommend to store the project now so that the settings in the dialog boxes do not get lost. In case of simple storing the project is called **Noname**.

An own project directory should be prepared for each project to be created. For this purpose, the project should be stored with **Save as** into a particular project directory.

- All path names within a project are relative and refer to the project directory.
- If you want to transfer a project to another PC, simply copy the project directory to the corresponding PC.



##### How to define the file name and directory for a new project...

1. Go to the *Save as* dialog box and select the directory in which you want to store the new project.
2. Enter a name for the new project in the **File name** input field.
3. Click **OK** to confirm the settings for the new project and close the *Save as* dialog box.
4. Go to the *New project* dialog box and click **Next** to proceed with the next step.

#### 6.1.5 Step 5: Adding a slave axis

New slaves are added at the end of the list. You can enter a symbolic name for the new slave which will be indicated on your *worksheet*.



##### Tip!

The menu commands mentioned are partly also included in the context menu of the right mouse button.

## Cam Designer Basic

Operation

Create a new project



### How to add another slave to your worksheet...

1. Mark the master axis in the object list.
2. Select the command **Edit**→**Slave axes**→**Add new axes**.
  - The dialog box *Project settings of slave 2* is displayed (optional). You can accept the settings.

3. Define the name and properties of the slave axis in the dialog box *Project settings*.
  - The name of the slave is also used as name for the LCx file.
  - The maximum product number determines the minimum number of **curves**. The maximally possible entry depends on the target system.

▶ [How to define the properties of the slave...](#) (📖 26)
4. Select **OK** to accept the setting and close the dialog box.

- ▶ Create for the example a project with three slave axes.
- ▶ The finished product must look as follows:

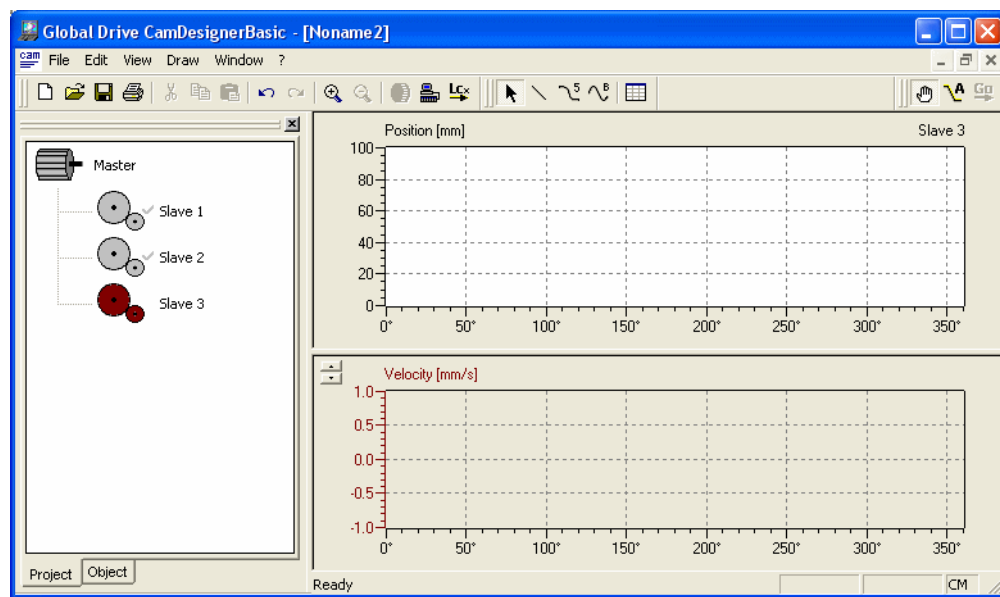

# Cam Designer Basic

Operation

Create a new project

## 6.1.6 Creating further products



### Note!

The path of the LCx-file must not be changed.



### How to create further projects in »Cam Designer Basic«:

1. Select the command **File**→**Open** to open a project already created from the directory which already contains project data (\*.cam).
2. Select an available product to be loaded and press the **Open** button.
  - The selected product, in this example product2, is loaded by the »Cam Designer Basic«.

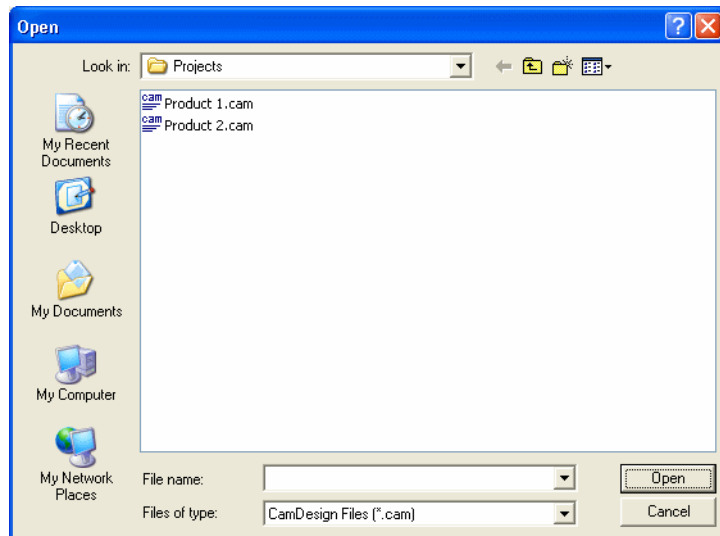

3. Select the command **Edit**→**Project settings** to open the dialog box *Settings*.

4. Enter a product number which has not been assigned yet, e.g. 3, into the register **General**, input field **Product number**.

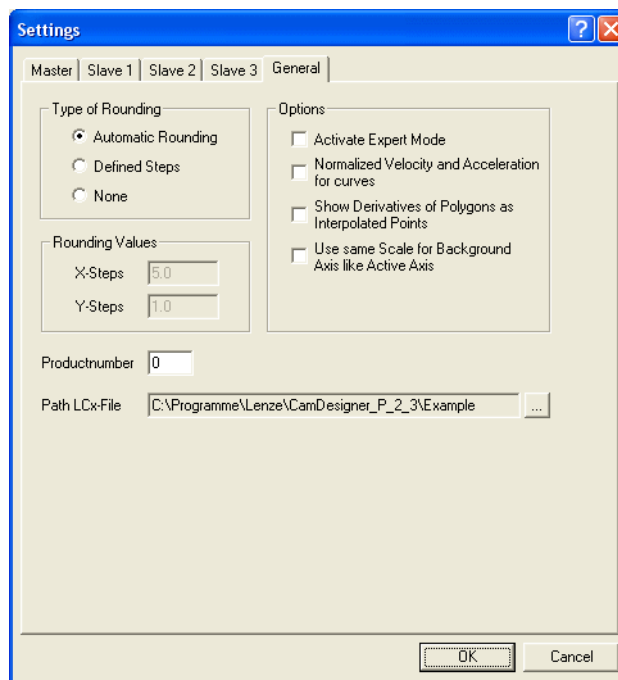

5. Store the profile e.g. as product3 and process it, if required.

### Next steps

Now you can assign the import files for the slave to the product and add more slaves and products to your worksheet, if required.

## Cam Designer Basic

Operation

Open an existing project

### 6.2 Open an existing project



#### Tip!

- It is possible to open several projects (*worksheets*) simultaneously in the »Cam Designer Basic«. The commands for arranging the *worksheets* can be found in the "Window" menu.
- With a click on the entries **1...4** in the **File** menu you can open one of the four projects edited last.



#### How to open an existing project...

1. Click the symbol  in the *symbol bar* or select **File**→**Open**.
2. Select the corresponding project file (\*.cam) in the dialog box *Open*.
3. Press the button **Open** .
  - After this, the project worksheet will be displayed in the workspace.

#### 6.2.1 Selecting the properties of a slave

The properties of a slave can always be changed.



#### How to change the properties of a slave...

1. Select the corresponding slave axes and select **Properties of the slave axis** from the menu of the right mouse button.
2. Go to the *Project settings* dialog box and enter the new settings.
  - ▶ [How to define the properties of the slave...](#) (📖 26)
3. Select **OK** to accept the settings and close the dialog box.

**Tip!**

If you want to change the settings of several axes/products you can also use the command **Edit→Project settings....**

In the *Project settings* dialog box that appears you can quickly change between the different axes/products by clicking the corresponding tabs:

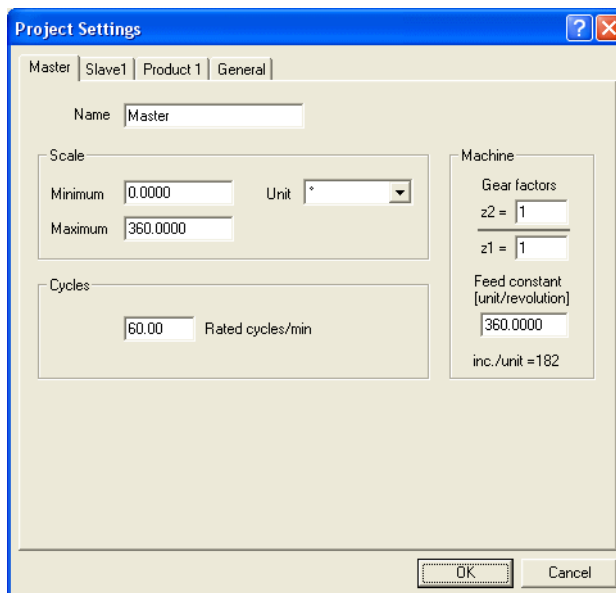

## 6.2.2 Deleting a slave

**Note!**

This function only deletes a slave from the project/worksheet. The corresponding LCx file is **not** deleted!

Deleting a slave cannot be undone!

**How to delete a slave...**

1. Select a certain slave axis in the project structure.
2. Select **Edit→Slave axes...→Delete a slave axis** or select **Delete slave axis** from the menu of the right mouse button.
3. Confirm the query with **Yes** or **No** accordingly.

## Cam Designer Basic

Operation

Connection with the OPC server

### 6.3 Connection with the OPC server

The internal Lenze DriveServer is used for communication between »Cam Designer Basic« and target system and LCx-file transfer.

- ▶ The DriveServer provides easy integration of drives into open automation structures based on OPC (*OLE for Process Control*).
- ▶ A specially adapted variant of the DriveServer and the bus server for the system bus (CAN) is part of the »Cam Designer Basic« installation package.



Select **File**→**Connect to OPC server** to connect the Cam Loader to the OPC server or cancel the connection.

A hook in front of the menu command indicates the connection with the OPC server.

### 6.4 Downloading the drive data

If connection with the OPC server has been established it is possible to transfer the drive data for **several** slaves in one step. ▶ [Connection with the OPC server](#)

- ▶ The configuration files (LCx files) for the selected axes are created first.
- ▶ If you have an online connection with the corresponding target system the LCx file will be directly transferred to the target system.



#### Note!

With the 9300 servo PLC, the LC9 file can only be downloaded if the target system includes a DDS project based on **Template Cam**.



#### How to download the drive data...

1. Select **File**→**Download of several axes...** .
  - This command can only be executed if the Cam Loader is connected to the OPC server.
2. Go to the *Download to controllers* and select the slaves to be downloaded:
  - If the option **If necessary, download all data without queries** is activated the data will be downloaded without further queries.
  - If the option **Do not show this dialog again until next program start** is activated this dialog will not be indicated again until the next program start. This can be useful for the commissioning of standard systems or in case of frequent downloads.

3. Click the **Start Download** button to start the data transfer.

**Note:** If you have not yet assigned a drive to one of the slaves the *Drive selection* dialog box opens automatically.

- Double-click the drive to be assigned to the slave in the DriveServer tree:
- Click **OK** to confirm your selection and repeat the assignment for other slaves, if necessary.

## 6.5 Saving the project



### Note!

If you open several project simultaneously in the »Cam Designer Basic«, this function refers to the project in the active window.



Click the  icon or select **File→Save** to save the project.



### Tip!

Save your project at regular intervals to protect your data against power failures or system problems.

If you want to create a backup project on another data carrier or in another directory use the command **File→Save as...** instead.

▶ [Saving a project under another name](#)

## 6.6 Saving a project under another name



### Note!

If you open several project simultaneously in the »Cam Designer Basic«, this function refers to the project in the active window.



### How to save an open project under another name...

1. Select **File→Save as...** to open the *Save as* dialog box.
2. Go to the **Save as** list field and select the directory in which you want to store the project.
3. Enter a name for the new project in the **File name** input field.

## Cam Designer Basic

Operation

Exiting Cam Designer Basic

- Click **OK** to save the project under the specified name in the selected directory and close the dialog box.
  - If you select the command **File→Save** the project will be saved with the new settings.



### Note!

Information on the single menu items can be found in the Online Help.

Make sure that the product numbers are not assigned twice and the correct path has been selected for the LCx-file.

If the project is stored with **Save as...**, it should be stored in the same directory as the LCx-files.



### Tip!

This way you can create a new project or a backup project on another data carrier or in a directory other than the project directory on the basis of the current project.

## 6.7 Exiting Cam Designer Basic



### Note!

If you have not saved the changes made in one or several projects you will be asked if you want to save them before exiting the Cam Loader.



Select **File→Exit** or click the Window icon **X** in the Title bar to exit the »Cam Designer Basic«.

## 7 Functions

### 7.1 Working with the worksheet

To create a cam profile in the »Cam Designer Basic«, specify the required data (boundary conditions) on the worksheet using graphical elements. This worksheet has two levels arranged on top of each other. The lowest level is the **Object Input Mode** and the second level is the **Interpolation Mode**.

In each of the levels the graphical elements of the underlying levels are visible and are used for the following calculations. Only the elements of the active level can be edited, not the elements of the underlying level(s). This principle is analogous to working with tracing paper. Here, too, information from the lower sheets is available without being able to change them.

### 7.2 Settings for the worksheet

Select **Edit→Project settings...** to open the *Settings* dialog box. Here you can change the settings of the corresponding project.



#### Note!

- Ensure that the maximum value of the range is higher than the minimum value.
- If you change the area boundaries afterwards and the project already contains graphical objects, the objects outside the new area boundaries will be deleted!

### 7.3 Object Input Mode

The **Object Input Mode** uses graphical elements (objects) to describe the problem to be solved.

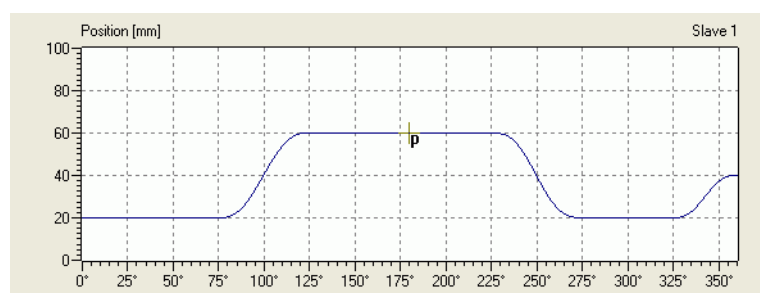

## Cam Designer Basic

Functions

Interpolation mode

### 7.4 Interpolation mode

In **Interpolation Mode**, a table of base points is generated from the ideal cam. These value pairs can then be transferred to the selected target system (**Servo PLC, ECS EA... or 9300EK servo cam**).

#### Uniform distribution of the base points

All points are distributed with the same spacing along the domain.

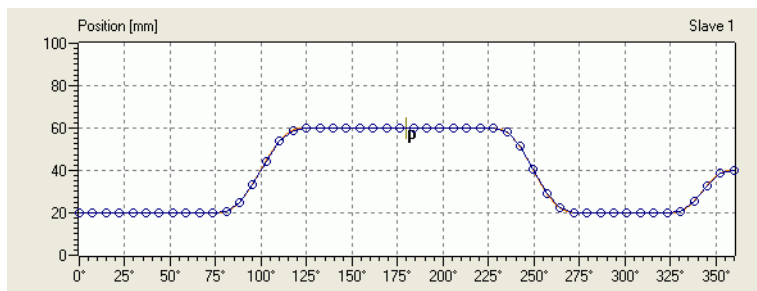

#### Note!

Before executing the interpolation, ensure that the curve trace is closed.

### 7.5 Worksteps required for a new cam

The following steps are required to create a new cam:

- ▶ [Settings of the worksheet](#) (41)
- ▶ [Creation of profiles](#) (41)

## 7.6 Settings of the worksheet



### How to configure the worksheet:

1. Select the menu command **Edit→Project settings** in the »Cam Designer Basic«.
  - The *Settings* opens.
2. Go to the *Settings* dialog box, change to the **Master** or **Slave** tab for the master and slave axis and define the units for the axes.
3. Close the *Settings* dialog box with **OK**.

## 7.7 Creation of profiles

A simple profile is created and transferred to the controller.

For a better representation and obtaining a zero axis, go to the *Settings* dialog box of the slave axis and select a negative value (e.g. -20,000) in the **Minimum** input field and a positive value (20,000) in the **Maximum** field.



### Tip!

The following figure shows the options of creating a profile in the »Cam Designer Basic«.



### How to create a profile:

1. Select the command **View→Object Input Mode** to take the worksheet to the input mode.
2. Create the graphical elements required by using the command in the **Draw** menu.
3. Create a profile using all tools available. Ensure that the profile objects do not overlap each other and the profile is closed.
4. Go to the interpolation mode selecting **View →Interpolation mode**.
5. Compile the profile selecting **File→Create and download LCx-file**.
6. The profiles, cams etc. are transmitted to the LCx-files.

# Cam Designer Basic

Functions

Creation of profiles

The worksheet and time derivation might look as follows:

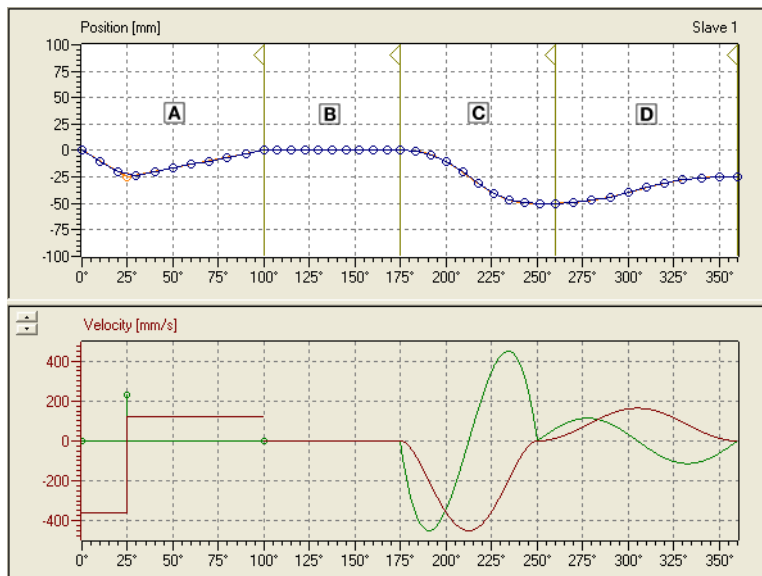

	Profile object	Function
A	Table	Creates a polyline. The base points are connected by lines. If the object is selected, it can be edited using the command <b>Edit→Object Properties...</b>
B	Line:	Section with a straight line.
C	5th-grade polynomial (x5)	This section contains a mathematical function $f(x)=ax^5+bx^4+cx^3+dx^2+ex+f$
D	Sloped sine function	This section contains a sloped sine function

## 7.8 Closed profile

**Tip!**

To clearly represent the creation of closed profiles, only the corresponding sections of the »Cam Designer Basic« are shown.



How to create a closed profile:

- ▶ First, the important sections (gradients, lines etc.) of the profile must be defined.
- ▶ Then, the sections must be connected without jerk, if possible. For this purpose, the »Cam Designer Basic« has
  - the sloped sine function
  - the 5th-grade polynomial (x5)

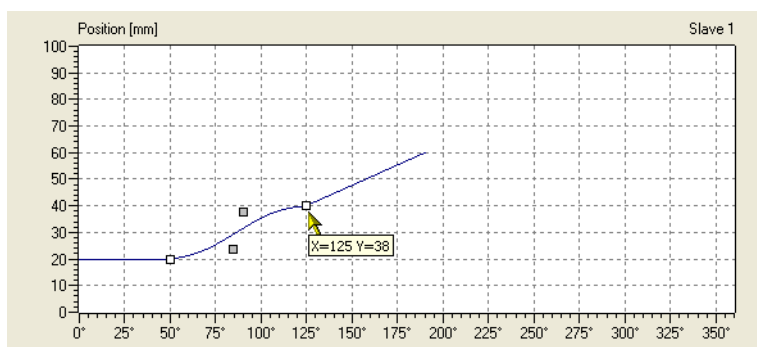

A jerk-free connection in a profile means:

- ▶ The coordinates of the end point of an object must be identical with the initial point of the following connected object.
- ▶ The gradient of the end point of an object must be identical with the following connected object.

Optimise the connection between the 5th-grade polynomial (x5) and a sloping line.

Here, the right end point of the polynomial must be connected with the left end point of the line.

## Cam Designer Basic

Functions

Closed profile

- ▶ Select the line with a mouse-click.
- ▶ Select the menu command **Edit→Project settings**.  
Go to the *Line properties* dialog box to open the **Conditions** register.
- ▶ Select and copy the value for velocity. The tab cannot be edited.

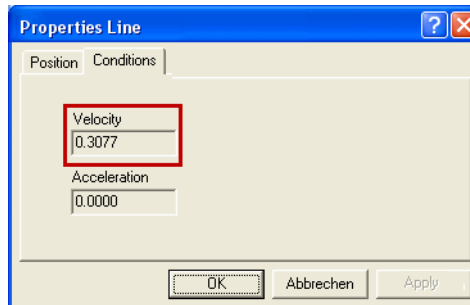

- ▶ Select the 5th-grade polynomial (x5) with a mouse-click.
- ▶ Select the menu command **Edit→Project settings**.  
Go to the *5th-grade polynomial properties* to open the **Conditions** register.
- ▶ Paste the copied value into the input field **Right Velocity**.

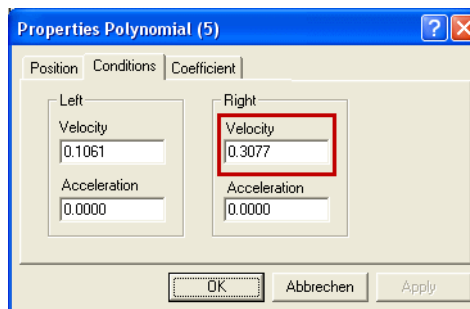

The characteristic of both objects is smooth at the connecting point.

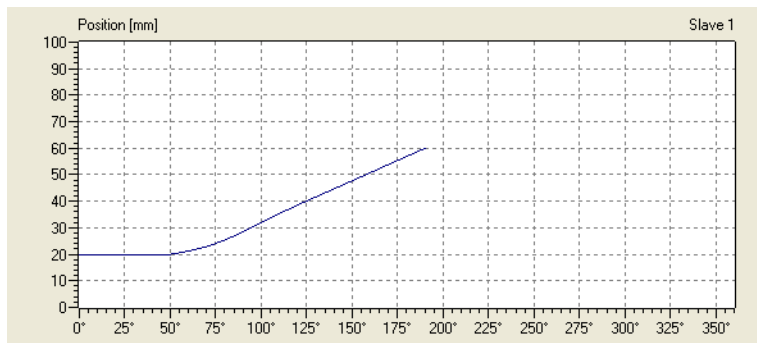

- Proceed the same way for all connections. A closed profile with several objects can look as follows :

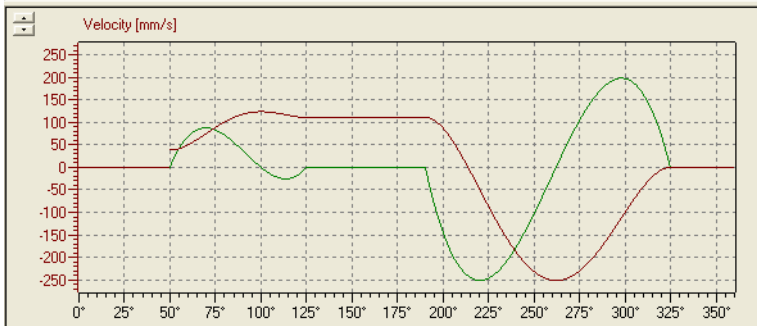
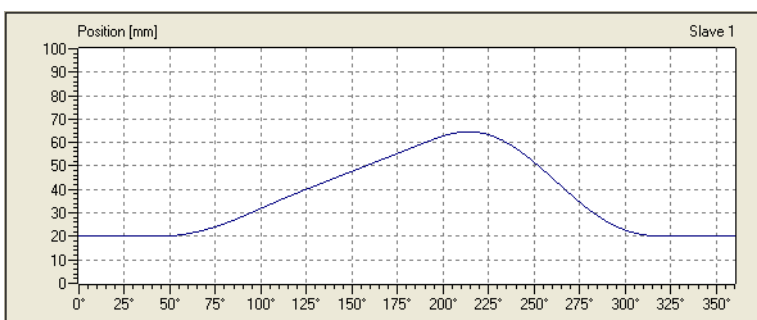

# Cam Designer Basic

Functions

The cam group

## 7.9 The cam group



### Note!

Only available for Software Package - Cam

The settings only apply to the product selected. For the other products, the settings have to be repeated.

Select **View→Edit Cam** in the »Cam Designer Basic« to take the bottom window (output area) to the corresponding mode.

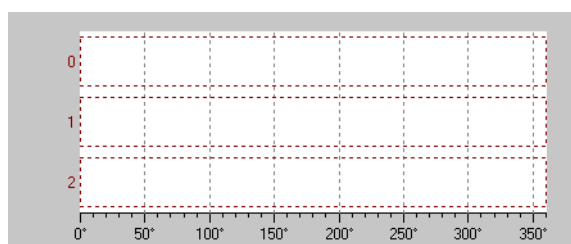

### 7.9.1 Defining the cam type and cam reference



#### Tip!

The cam group can either refer to the X axis or to the Y axis. The cam group functions are available in the context menu of the right mouse button.







#### How to define the cam type and cam reference:

1. First, define the cam reference for the current data set under **Cam for Slave Axis**.
  - Subsequent changes are not possible. The selected cam data will be deleted and must be entered again.
2. The cam types for the individual tracks can be defined using the context menu of the right mouse button.

Position cam in positive effective direction  
 Position cam in negative effective direction  
 Position cam Both  
 Time-based cam in positive effective direction  
 Time-based cam in negative effective direction

- If you right-click in the track, you can directly change the came type.
3. Select **Add New Cam** to add a new cam to the corresponding track.
    - You can add up to four cams to every track.

## 7.9.2 Cam types

Illustration	Meaning
	<b>Position cam in positive effective direction</b> Switch on and switch off point are defined by positions. The cam switches if the direction of the axis is positive (positive speed).
	<b>Position cam in negative effective direction</b> Switch on and switch off point are defined by positions. The cam switches if the direction of the axis is negative (negative speed).
	<b>Position cam Positive and negative</b> Switch on and switch off point are defined by positions. The cam switches in positive and negative direction of the axis.
	<b>Time-based cam in positive effective direction</b> The cam switches on at the switch on point if the direction of the axis is positive (positive speed). After the selected time, the cam switches off.
	<b>Time-based cam in negative effective direction</b> The cam switches on at the switch on point if the direction of the axis is negative (negative speed). After the selected time, the cam switches off.

Select **Properties of Cam** to edit the cam subsequently. In this dialog, time and length data can be accurately entered. The dialog box is always the same for all cam types. Only the corresponding fields on the dialog box are active.

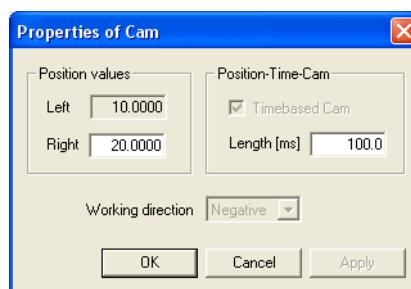

Dialog object	Meaning
Input field <b>Left</b>	Initial value of the cam
Input field <b>Right</b>	Final value of the cam
Selection field <b>Effective Direction</b>	Positive or negative effect
Input field <b>Length [ms]</b>	Cam is active (only with time cam)

## Cam Designer Basic

Functions

Export of profile data

### 7.10 Export of profile data

- ▶ Exporting the profile data to the controller via
  - Drive PLC Developer Studio (Servo PLC and ECSEA).
  - Global Drive Loader.
  - Cam Loader.

**Target system - Servo PLC, ECSEA and 9300EK servo cam**





#### Note!

The 9300EK servo cam exclusively works with the Online download.



#### How to export the profile data:

1. The data must be compiled before being exported.
  - For this purpose select **View→Interpolation Mode** or click  and then select **Edit→Start of Calculation** or press .
2. Select the corresponding slave axis in the »Cam Designer Basic« by means of double-click.
3. Go to the interpolation mode and press the **LCx** file.
  - If this function is executed for the first time, a dialog appears which is confirmed with **OK**. The system now creates a file with the name of the slave axis and the ending \*.lc9 or \*.lc7.
  - Compiling must be repeated for new profiles, cam groups or position markers and changes made.
  - After every compiling, the data are transferred to the \*.lc9-file or \*.lc7-file.

The following two steps are only required for the Software Package - Cam Offline download.

4. Double-click **Resources→CamSupport** in the DDS.
5. Click **Add Profile Data to Project** .
  - A dialog appears in which you can select the \*.lc9-file.



#### Tip!

Do not forget to save your CamDesigner Basic project on hard disk or diskette, in case you want to make subsequent changes. Select **File→Save as...** to save the CamDesigner Basic project under a new name.

- ▶ Repeat the above-described steps to create all cams required by means of the »Cam Designer Basic«.
- ▶ After creating all profiles required by means of »Cam Designer Basic«, you can exit the »Cam Designer Basic« with **File→Exit**.

## 7.11 Cam Designer Basic Online Download





### Note!

The download time increases if

- a high bus load (cross communication) exists.
- many data was changed.



### How to make an Online Download:

1. Switch the »Cam Designer Basic« online by clicking **File→Connection to OPC server** or  .
  - The button **online/offline** is only active if the **LDS-DriveServer** has been started. The icon  for the **LDS-DriveServer** is situated in the status bar.
  - If the red point in the icon becomes green, the system is *online*.
2. Select **Edit→Project settings** to open the *Settings* dialog box.
3. Select in **Controller data** the drive to which the data is to be downloaded.
4. Select **File→Create and download LCx-file** or  to activate the profile or cam download.
  - The data for the current slave axis are written into the \*.lcx-file.
  - After the download has been started with the button, a progress dialog appears.



### Tip!

For the commissioning of production machines, the \*.lc9-file can be attached to the PLC program.

# Cam Designer Basic

## Appendix

### Error numbers, causes & remedies

## 8 Appendix

### 8.1 Error numbers, causes & remedies

Error number	Cause	Remedy
<b>Errors within the DriveServer</b>		
E7C18000	Error during download preparation.	Repeat download.
E7C18001	PLC has not stopped.	Stop the PLC program in the target system.
E7C18002	Controller inhibit is not set.	Set controller inhibit in the target system (e.g. via terminal 28 or code C0040).
E7C18003	Incorrect data type (no LC9 file).	Create new LC9 file.
E7C18004	Check sum check is negative (faulty check sum).	Restart the download. Increase time-out time in the system bus configuration tool (e.g. to 3 seconds).
E7C18005	Item can momentarily not be accessed due to download.	Repeat download after a few minutes or restart your PC.
E7C18006	Target system is momentarily busy copying RAM blocks.	Start the PLC program in the target system.
E7C18007	Error occurred after the download.	Repeat download.
E7C18008	Error after version comparison during download of an LC7 file. <ul style="list-style-type: none"> <li>Different versions in LC7 file and target system.</li> </ul>	Update the operating system of the 9300 EK.
E7C18009	No template "Cam" in the target system.	Create DDS project based on Template Cam and transfer it into the target system.

## 8.2 Glossary

## A

<b>Absolute data model</b>	<p>Contains both the X and the Y coordinate. Therefore requires more space than the relative data model. The points are 1:1 transferred from the Cam Loader to the target system:</p> <ul style="list-style-type: none"> <li>• Advantage: The distance between the points can be variable. This allows to optimise the distribution of the points according to the cam profile characteristics.</li> <li>• Disadvantage: Compared to the relative data model, less points can be saved.</li> </ul> <p>▶ <a href="#">Relative data model</a></p>
<b>Application window</b>	Window in which programs are displayed under Windows.

## C

<b>Code</b>	Lenze device parameter used to select the device functionality.
<b>COM</b>	Abbreviation for " <b>Component Object Model</b> ": Architecture developed by Microsoft® for the interaction of separately executable software components (objects) that communicate with each other in the same way and are only connected to each other when the program is being executed.

## D

<b>DCOM</b>	<p>Abbreviation for "<b>Distributed Component Object Model</b>": COM in which the executable objects can be distributed to different computers within a local network.</p> <p>▶ <a href="#">COM</a></p>
<b>DDS</b>	Abbreviation for " <b>Drive PLC Developer Studio</b> ": Development environment for the creation of IEC 61131 programs for Lenze PLCs.
<b>Document window</b>	Window with graphical user interface displayed by a user program in which a document is created, displayed and edited. Document windows are usually sub-windows of the program windows.
<b>Drive PLC Developer Studio</b>	See DDS.
<b>DriveServer</b>	<p>Lenze software which enables easy integration of drives into open automation structures based on OPC ("OLE for Process Control").</p> <p>▶ <a href="#">OPC</a></p>

## G

<b>Global Drive Loader</b>	Lenze software used to transfer PLC programs, parameter sets and application data to Lenze target systems.
----------------------------	--

## H

<b>Hyperlink</b>	Highlighted reference which is activated by a mouse click.
------------------	--

# Cam Designer Basic

## Appendix

### Glossary

#### I

**IPC** Abbreviation for Industrial PC. Industrial PCs are used in case of special environmental conditions, e.g. dirt or vibrations. They are slot CPUs with powerful processors and TFT displays (often with touch screens).

#### O

**OLE** Abbreviation for "Object Linking and Embedding": Integration of operational objects into other applications, e.g. Microsoft® Excel spreadsheets into Microsoft® Word documents.

**OPC** Abbreviation for "OLE for Process Control": Defines an interface based on the Microsoft® Windows® technologies OLE, COM and DCOM which enables data exchange between different automation devices and PC programs regardless of driver and interface problems.

▶ [COM](#)

▶ [DCOM](#)

#### P

**PDF** Abbreviation for "Portable Document Format". Universal file format developed by Adobe for the exchange of electronic documents. The Adobe® Reader® is provided free of charge and can be used to display and print PDF files independently of the application and platform used to create them.

**PLC** Abbreviation for "Programmable Logic Controller".

▶ [PLC](#)

**PLC** Abbreviation for "Programmable Logic Controller".

▶ [PLC](#)

**Relative data model** Only contains the difference between adjacent Y coordinates and therefore requires less space than the absolute data model. The distance between the X coordinates is transferred as a fixed-comma value to the target system. This leads to a certain difference between the imported data and the coordinates calculated by the target system. To compensate for this inaccuracy, the Y values are re-calculated by means of interpolation.

- Advantage: Compared to the absolute data model, more points can be saved.
- Disadvantage: The distance between the X coordinates of the points must always be the same.

▶ [Absolute data model](#)

#### T

**Title bar** Bar at the top of the application window including the program icon and the program name on the left and the window icons on the right.

#### V

**VDI 2143** VDI guideline "Motion rules for cam mechanisms"

#### W

**Window icon** Button at the right end of the title bar which can be used to change the size of the window or to close the window.

**Worksheet** Table including all axes and products of a system or machine project.

## 9 Index

### A

Absolute data model [26](#)  
 Acc a slave axis [29](#)  
 Adding a slave [34](#)  
 Appendix [50](#)

### C

Cam controller [46](#)  
 Cam Designer Professional [11](#)  
 Cam Manager [11](#)  
 Cam type, cam reference [46](#)  
 Cam types [47](#)  
 Closed profile [43](#)  
 Conventions used [5](#)  
 Copyright [2](#)  
 Copyright information [2](#)  
 Creating products [32](#)  
 Creation of profiles [41](#)  
 Curve [26](#)  
 Cycles [24](#)

### D

Data model [26](#)  
 Deleting a slave axis [35](#)  
 Direct help [14](#)  
 Document window [20](#)  
 Download [36](#)

### E

Electrical shaft [22](#)  
 Error numbers [50](#)  
 Example project [21](#)  
 Exiting the program [38](#)  
 Export of profile data [48](#)

### F

Feed constant [26](#)  
 Functions [39](#)

### G

GDC file [26](#)  
 Gear factors [26](#)

### I

Imprint [2](#)  
 Input mode [39](#)  
 Interpolation mode [40](#)

### L

Language selection [15](#)  
 Layout of the safety information [6](#)  
 LCx file [32](#)

Liability [2](#)

### M

master [22](#)  
 Menu bar [15](#)  
 Motion rules [13](#)  
 Motion tasks [12](#)

### N

New project [22](#)

### O

Object [18](#)  
 Online Download [49](#)  
 OPC server [36](#)  
 Open project [34](#)  
 Operation [21](#)  
 Output area [18](#)

### P

Profile options [27](#)  
 Project [17](#)  
 Project directory [29](#)  
 Project structure [17](#)

### S

Saving the project [37](#)  
 Screen divider [18](#)  
 Servo cam [9](#)  
 Slave axis [24](#)  
 Software Package - Cam [9](#)  
 Status bar [19](#)

### T

Title bar [15](#)  
 Toolbar [16](#)  
 Trademarks [2](#)

### U

Uniform distribution [40](#)  
 User interface [7, 14](#)

### W

Working with the worksheet [39](#)  
 Worksheet setting [39, 41](#)