

Signalisierung

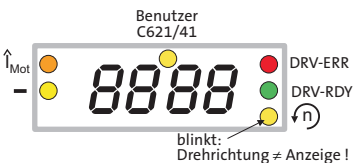

DRV-RDY DRV-ERR

Init: ● ●

ReadyToSwitchOn: ● ●

SwitchedOn: ● ●

OperationEnabled: ● ●

Warning: { ● ●
● ●
● ●

Trouble: ● ●

Fault: ● ●

SystemFault: ● ●

Eingabe



Keypad-Menüstruktur

Status	Passwort	Menü	Code	Subcode	Aktion
--------	----------	------	------	---------	--------

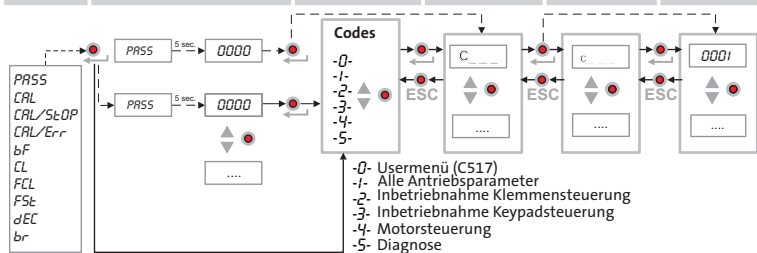

Motordrehzahl mit Keypad verändern



Lenze-Einstellung mit Keypad laden

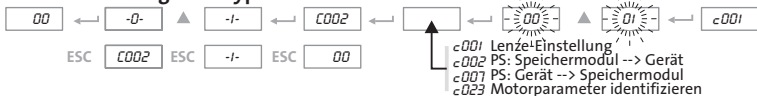

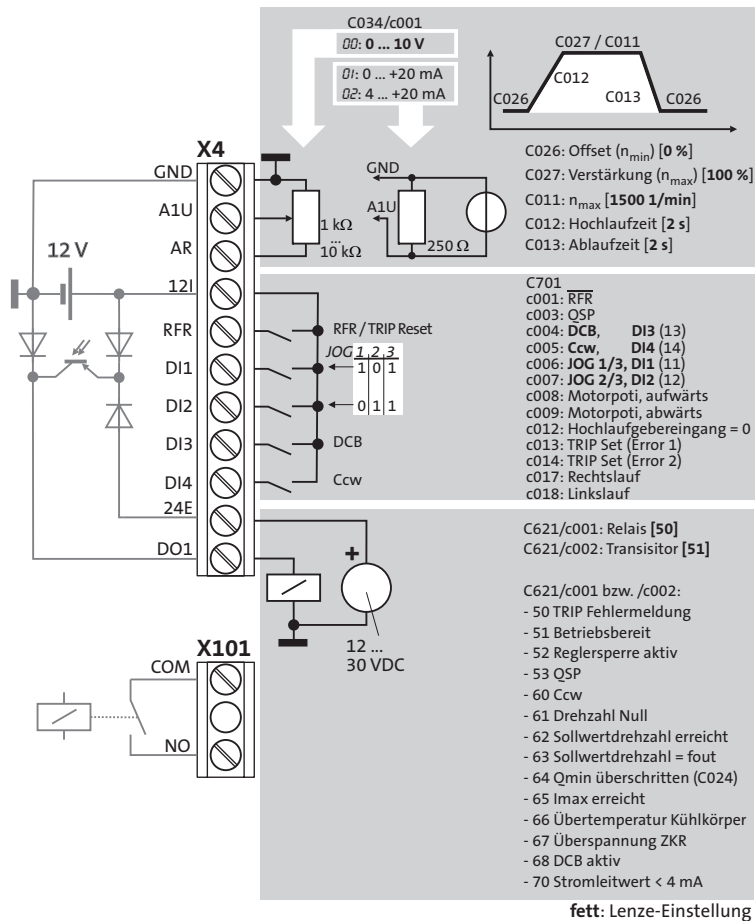

fett: Lenze-Einstellung

Signalling

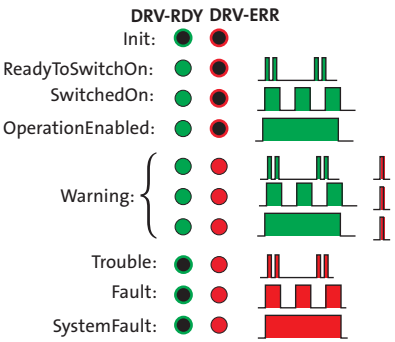
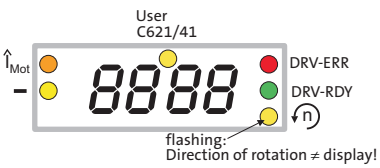

Input



Keypad menu structure

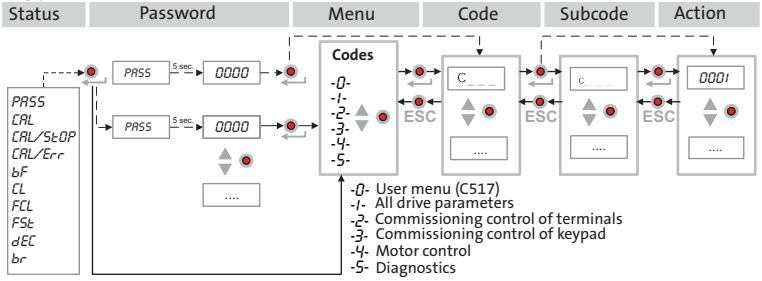

Using keypad to change motor speed



Using keypad to load Lenze setting

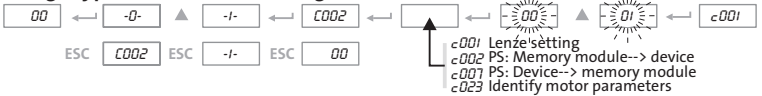

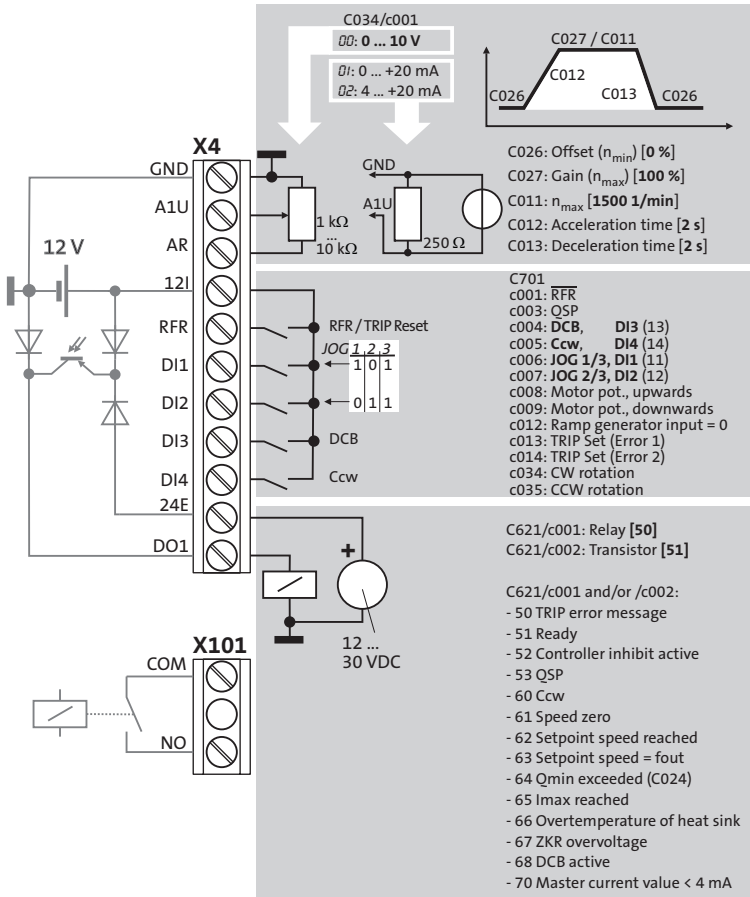

bold: Lenze setting

Signalisation

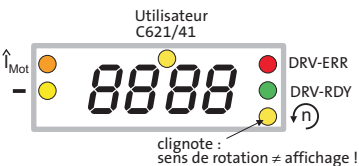

DRV-RDY DRV-ERR

Init: ● ●

ReadyToSwitchOn: ● ●

SwitchedOn: ● ●

OperationEnabled: ● ●

Warning: { ● ●
● ●
● ●

Trouble: ● ●

Fault: ● ●

SystemFault: ● ●

Saisie



Structure de menu du pavé numérique

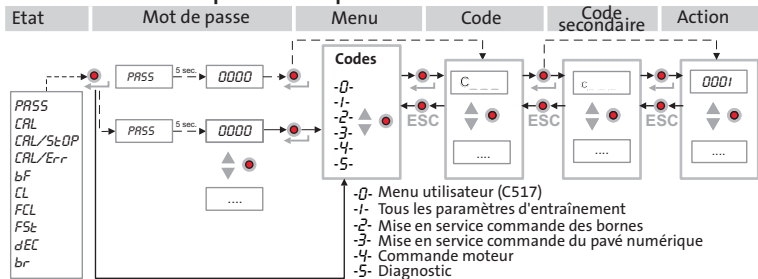

Modifier le couple moteur à l'aide du pavé numérique



Charger le réglage Lenze à l'aide du pavé numérique

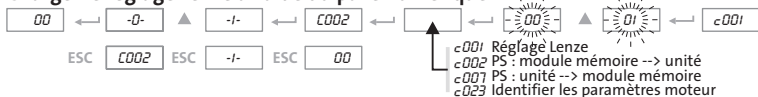

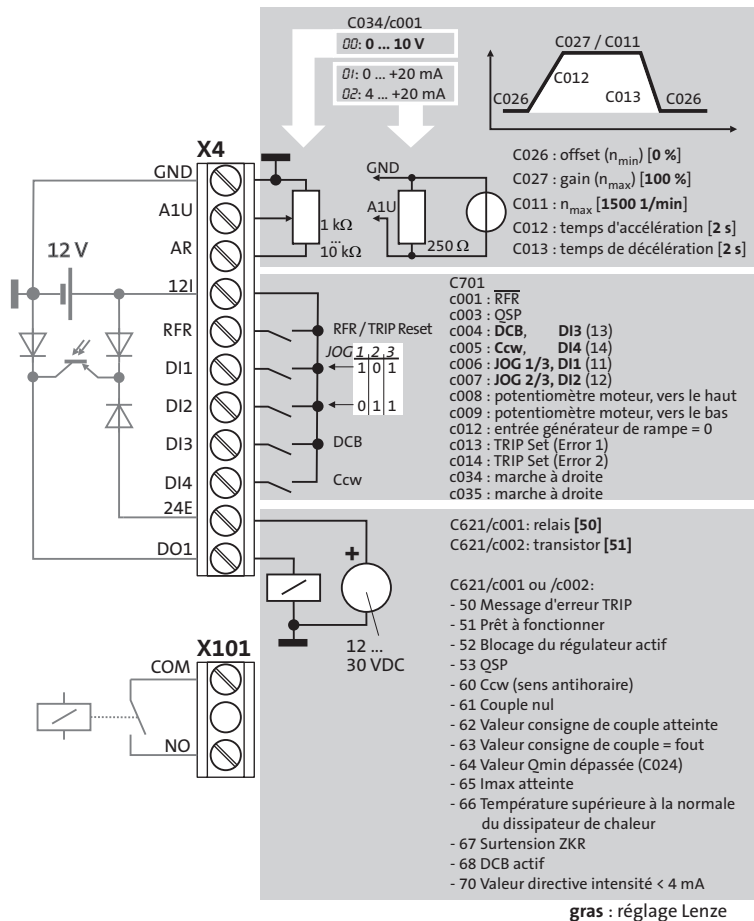

Señalización



DRV-RDY DRV-ERR

Init: ● ●

ReadyToSwitchOn: ● ●

SwitchedOn: ● ●

OperationEnabled: ● ●

Warning: { ● ●
● ●
● ●

Trouble: ● ●

Fault: ● ●

SystemFault: ● ●

Entrada



Estructura de menús del teclado

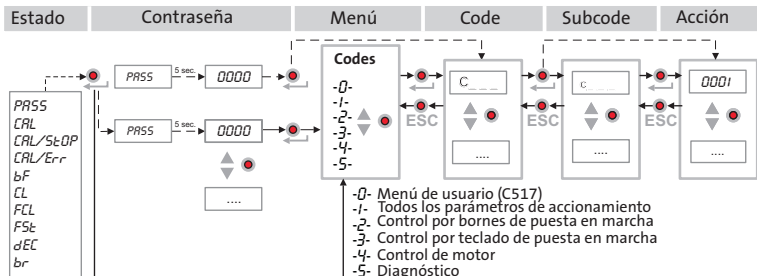

Modificar la velocidad del motor con el teclado



Cargar ajustes de Lenze con el teclado

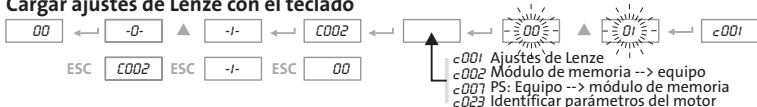

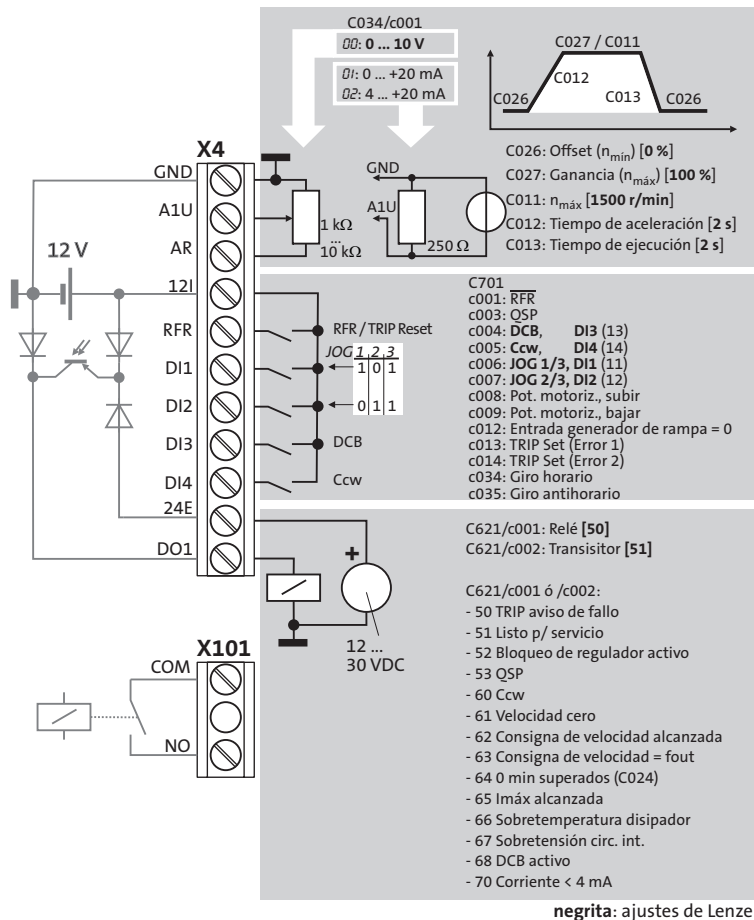

Segnalazione

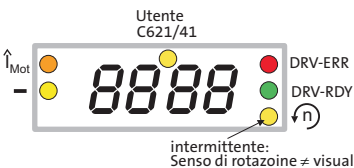

DRV-RDY DRV-ERR

Init: ● ●

ReadyToSwitchOn: ● ●

SwitchedOn: ● ●

OperationEnabled: ● ●

Warning: { ● ●
● ●
● ●

Trouble: ● ●

Fault: ● ●

SystemFault: ● ●

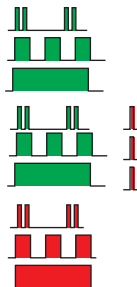

Ingresso



Struttura dei menu da tastiera

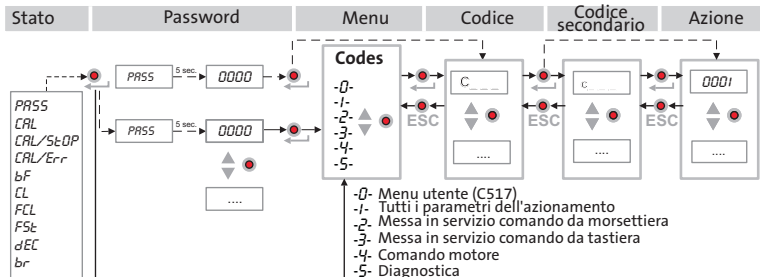

Modifica del regime motore da tastiera



Caricamento delle impostazioni Lenze da tastiera

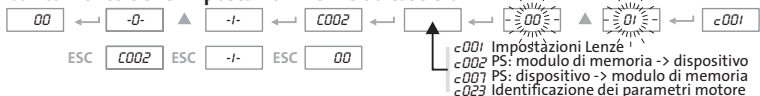

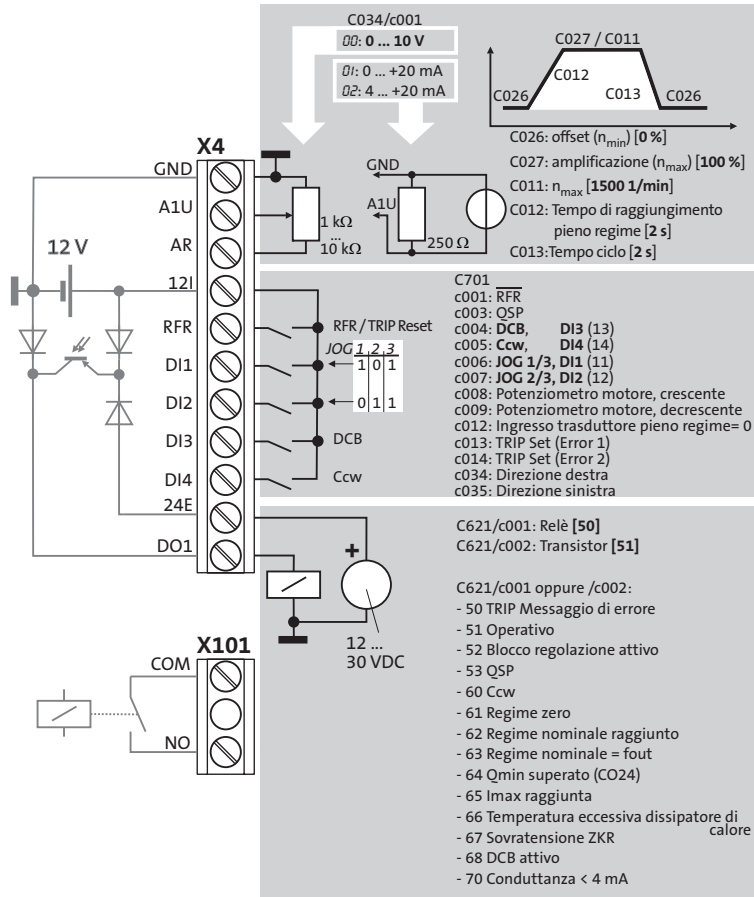

grassetto: impostazioni Lenze