

L-force *Drives*

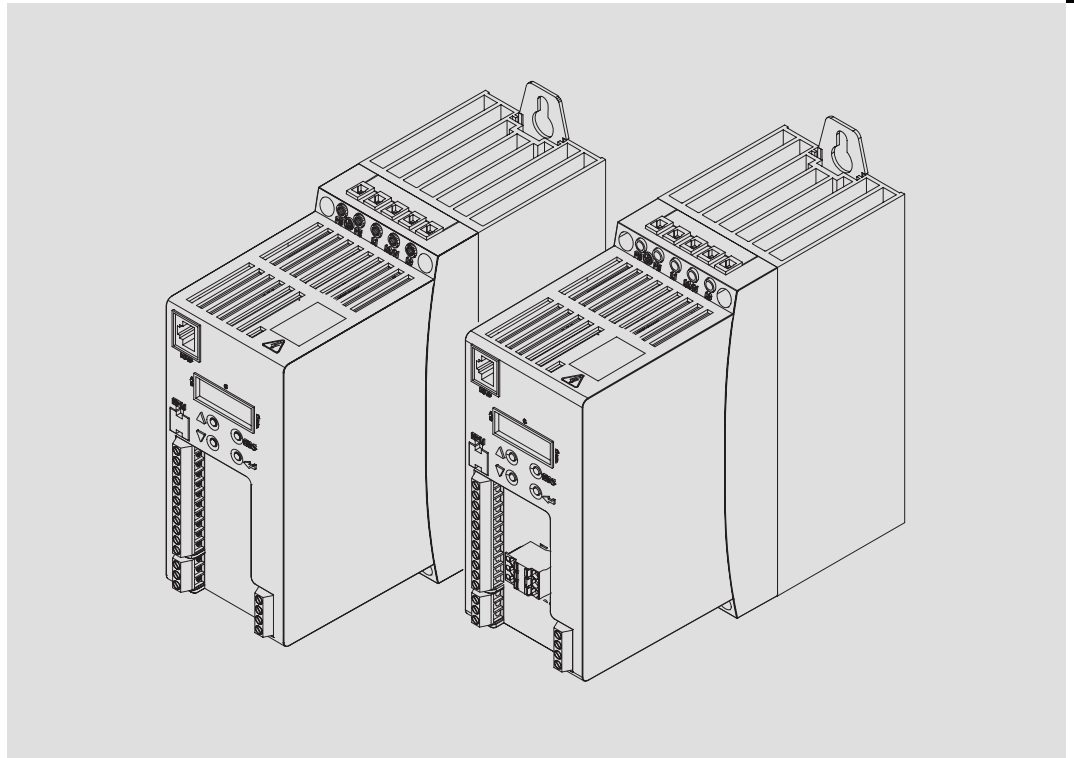

Hardware Manual

8400 0.25 ... 3.0 kW



E84A... - BaseLine C/BaseLine D

8400 frequency inverter

1	About this documentation	6
1.1	Document history	6
1.2	Conventions used	7
1.3	Notes used	8
2	Safety instructions	9
2.1	General safety information	9
2.2	General safety and application instructions for Lenze motors	12
2.3	Residual hazards	15
3	Product description	16
3.1	Device features	16
3.2	Overview of the devices	17
3.2.1	Determining the device type	18
3.2.2	Type code	19
4	Technical data	20
4.1	General data and operating conditions	20
4.2	Rated data	24
4.2.1	Overview	24
4.2.2	Operation at rated mains voltage 230 V	26
4.2.3	Operation at rated mains voltage 400 V	29
4.2.4	Operation at rated mains voltage 500 V	33
4.3	Overcurrent operation	36
4.3.1	Device overload for 15-s cycle	37
4.3.2	Device overload for 180-s cycle	38
4.4	Terminal description	39
4.4.1	Overview	39
4.5	Control terminals	40
4.5.1	External supply voltage 24 V	40
4.5.2	Analog input	41
4.5.3	Digital inputs	42
4.5.4	Digital outputs	42
4.5.5	Relay output connection	42
5	Mechanical installation	43
5.1	Important notes	43
5.2	Standard devices in the power range from 0.25 ... 3 kW	44
5.2.1	Assembly in built-in technique (standard)	44

6	Electrical installation	45
6.1	Important notes	45
6.1.1	Electrical isolation	47
6.1.2	Device protection	48
6.1.3	Maximum motor cable length	48
6.1.4	Motor protection	48
6.1.5	Interaction with compensation equipment	48
6.1.6	Safety notes for the installation according to UL or UR	49
6.2	Installation according to EMC (installation of a CE-typical drive system)	50
6.2.1	Shielding	50
6.2.2	Mains connection, DC supply	52
6.2.3	Motor cables	53
6.2.4	Control cables	54
6.2.5	Installation in the control cabinet	55
6.2.6	Wiring outside the control cabinet	57
6.2.7	Detecting and eliminating EMC interferences	59
6.3	Devices in the power range 0.25 ... 2.2 kW (1/N/PE AC 230 V)	60
6.3.1	Example circuits	60
6.3.2	Terminal assignment of the power connections	61
6.4	Devices in the power range from 0.37 to 3 kW (3/PE AC 400 V)	66
6.4.1	Example circuits	66
6.4.2	Terminal assignment of the power connections	67
6.5	Control terminals	72
6.5.1	Important notes	72
6.5.2	System bus connection (CANopen)	74
6.5.3	Analog input	75
6.5.4	External supply voltage 24 V	77
6.5.5	Digital inputs and outputs	78
6.5.6	Relay output connection	80
6.5.7	Diagnostics	81
7	Commissioning	82
7.1	Before switching on	82
7.2	Display elements and control panel	83
7.3	Menu structure	85
7.4	Preparing the commissioning procedure	86
7.5	Test commissioning	87
7.5.1	Test commissioning with keypad control	88
7.5.2	Test commissioning with terminal control	90
7.6	Messages	92

8	Braking operation	93
8.1	Braking operation without additional measures	93
8.2	Braking operation with external brake module	94
8.3	Braking operation with external brake resistor	95
8.3.1	Operation at rated mains voltage 400 V	96
8.3.2	Operation at rated mains voltage 500 V	97
8.3.3	Selection of the brake resistors	98
8.3.4	Rating for Lenze brake resistors	99
8.3.5	Wiring of brake resistor	100
8.4	Controlling the brake	102
8.4.1	Introduction	102
8.4.2	Rated data	103
8.4.3	Wiring	104
9	Accessories (overview)	105
9.1	Overview	105
9.2	Mains chokes	106
9.3	External brake resistors	107
9.4	Memory modules	108
9.5	Keypad	110
10	Appendix	111
10.1	Total index	111

1 About this documentation

Document history

1 About this documentation

Contents

This Hardware Manual informs you how to use the BaseLine C and BaseLine D version of the 8400 controller series as directed.

Validity

The information in this Hardware Manual applies to the 8400 BaseLine C and BaseLine D inverters with the following nameplate data:

Type	Type designation	From hardware version	From software version
8400 BaseLine C	E84AVBCxxxxxxX0	VA	03.00
8400 BaseLine D	E84AVBDxxxxxxX0	VA	03.00
8400 BaseLine D with digital output "DO1"	E84AVBDxxxxxxX1	1A	02.01
8400 BaseLine D without digital output "DO1"	E84AVBDxxxxxxX0	1A	01.00

Target group

This Hardware Manual is intended for all persons who design, install, commission, and adjust controllers of the 8400 Inverter Drives product range.



Tip!

Documentation and software updates for further Lenze products can be found on the Internet in the "Services & Downloads" area under <http://www.Lenze.com>

1.1 Document history

Material number	Version			Description
13251886	1.1	06/2008	TD03	First edition
13260428	2.0	07/2008	TD03	Complete revision
13277182	3.0	02/2009	TD03	New edition due to company reorganisation Corrections in Chapter "Technical Data" and "Electrical Installation"
13291897	4.0	03/2009	TD03	Corrections in Chapter "Mechanical Installation"

1.2 Conventions used

This documentation uses the following conventions to distinguish between different types of information:

Type of information	Writing	Examples/notes
Notation of numbers		
Decimal separator	Point	The decimal point is always used. For example: 1234.56
Warnings		
UL warnings	ⓘ	Are only given in English.
UR warnings	ⓘ	
Text font style		
Program name	» «	Lenze software For example: »Engineer«
Symbols		
Cross-reference	📖	Refers to additional information. For example 📖 16 = see page 16.

1 About this documentation

Notes used

1.3 Notes used

The following pictographs and signal words are used in this documentation to indicate dangers and important information:

Safety instructions

Structure of safety instructions:



Danger!

(characterises the type and severity of danger)

Note

(describes the danger and gives information about how to prevent dangerous situations)

Pictograph and signal word	Meaning
Danger!	Danger of personal injury through dangerous electrical voltage. Reference to an imminent danger that may result in death or serious personal injury if the corresponding measures are not taken.
Danger!	Danger of personal injury through a general source of danger. Reference to an imminent danger that may result in death or serious personal injury if the corresponding measures are not taken.
Stop!	Danger of property damage. Reference to a possible danger that may result in property damage if the corresponding measures are not taken.

Application notes

Pictograph and signal word	Meaning
Note!	Important note to ensure troublefree operation
Tip!	Useful tip for simple handling
	Reference to another documentation

Special safety instructions and application notes for UL and UR

Pictograph and signal word	Meaning
Warnings!	Safety or application note for the operation of a UL-approved device in UL-approved systems. Possibly the drive system is not operated in compliance with UL if the corresponding measures are not taken.
Warnings!	Safety or application note for the operation of a UR-approved device in UL-approved systems. Possibly the drive system is not operated in compliance with UL if the corresponding measures are not taken.

2 Safety instructions

2.1 General safety information

For your personal safety

Disregarding the following safety measures can lead to severe injury to persons and damage to material:

- ▶ Only use the product as directed.
- ▶ Never commission the product in the event of visible damage.
- ▶ Never commission the product before assembly has been completed.
- ▶ Do not carry out any technical changes on the product.
- ▶ Only use the accessories approved for the product.
- ▶ Only use original spare parts from Lenze.
- ▶ Observe all regulations for the prevention of accidents, directives and laws applicable on site.
- ▶ Transport, installation, commissioning and maintenance work must only be carried out by qualified personnel.
 - Observe IEC 364 and CENELEC HD 384 or DIN VDE 0100 and IEC report 664 or DIN VDE 0110 and all national regulations for the prevention of accidents.
 - According to this basic safety information, qualified, skilled personnel are persons who are familiar with the assembly, installation, commissioning, and operation of the product and who have the qualifications necessary for their occupation.
- ▶ Observe all specifications in this documentation.
 - This is the condition for safe and trouble-free operation and the achievement of the specified product features.
 - The procedural notes and circuit details described in this documentation are only proposals. It's up to the user to check whether they can be transferred to the particular applications. AC Technology Corporation does not accept any liability for the suitability of the procedures and circuit proposals described.
- ▶ Depending on their degree of protection, some parts of the Lenze controllers (frequency inverters, servo inverters, DC speed controllers) and their accessory components can be live, moving and rotating during operation. Surfaces can be hot.
 - Non-authorized removal of the required cover, inappropriate use, incorrect installation or operation, creates the risk of severe injury to persons or damage to material assets.
 - For more information, please see the documentation.
- ▶ High amounts of energy are produced in the controller. Therefore it is required to wear personal protective equipment (body protection, headgear, eye protection, ear protection, hand guard).

Safety instructions

General safety information

Application as directed

Controllers are components which are designed for installation in electrical systems or machines. They are not to be used as domestic appliances, but only for industrial purposes according to EN 61000-3-2.

When controllers are installed into machines, commissioning (i.e. starting of the operation as directed) is prohibited until it is proven that the machine complies with the regulations of the EC Directive 98/37/EC (Machinery Directive); EN 60204 must be observed.

Commissioning (i.e. starting of the operation as directed) is only allowed when there is compliance with the EMC Directive (2004/108/EC).

The controllers meet the requirements of the Low-Voltage Directive 2006/95/EC. The harmonised standard EN 61800-5-1 applies to the controllers.

The technical data and supply conditions can be obtained from the nameplate and the documentation. They must be strictly observed.

Warning: Controllers are products which can be installed in drive systems of category C2 according to EN 61800-3. These products can cause radio interferences in residential areas. In this case, special measures can be necessary.

Transport, storage

Please observe the notes on transport, storage, and appropriate handling.

Observe the climatic conditions according to the technical data.

Installation

The controllers must be installed and cooled according to the instructions given in the corresponding documentation.

The ambient air must not exceed degree of pollution 2 according to EN 61800-5-1.

Ensure proper handling and avoid excessive mechanical stress. Do not bend any components and do not change any insulation distances during transport or handling. Do not touch any electronic components and contacts.

Controllers contain electrostatic sensitive devices which can easily be damaged by inappropriate handling. Do not damage or destroy any electrical components since this might endanger your health!

Electrical connection

When working on live controllers, observe the applicable national regulations for the prevention of accidents (e.g. VBG 4).

The electrical installation must be carried out according to the appropriate regulations (e.g. cable cross-sections, fuses, PE connection). Additional information can be obtained from the documentation.

This documentation contains information on installation in compliance with EMC (shielding, earthing, filter, and cables). These notes must also be observed for CE-marked controllers. The manufacturer of the system is responsible for compliance with the limit values demanded by EMC legislation. The controllers must be installed in housings (e.g. control cabinets) to meet the limit values for radio interferences valid at the site of installation. The housings must enable an EMC-compliant installation. Observe in particular that e.g. the control cabinet doors have a circumferential metal connection to the housing. Reduce housing openings and cutouts to a minimum.

Lenze controllers can cause a DC current in the PE conductor. If a residual current device (RCD) is used for protection in the event of direct or indirect contact, a residual current device (RCD) of type B must be used on the supply side of the controller in case of a three-phase controller supply. Otherwise, a different protective measure must be taken, e.g. separation from the environment through double or reinforced insulation or separation from the supply system by means of a transformer.

Operation

If necessary, systems including controllers must be equipped with additional monitoring and protection devices according to the valid safety regulations (e.g. law on technical equipment, regulations for the prevention of accidents). The controllers can be adapted to your application. Please observe the corresponding information given in the documentation.

After the controller has been disconnected from the supply voltage, all live components and power connections must not be touched immediately because capacitors can still be charged. Please observe the corresponding stickers on the controller.

All protection covers and doors must be shut during operation.

Notes for UL-approved systems with integrated controllers: UL warnings are notes that only apply to UL systems. The documentation contains special UL notes.

Maintenance and servicing

The controllers do not require any maintenance if the prescribed operating conditions are observed.

Disposal

Recycle metal and plastic materials. Ensure professional disposal of assembled PCBs.

The product-specific safety and application notes given in these instructions must be observed!

2

Safety instructions

General safety and application instructions for Lenze motors

2.2

General safety and application instructions for Lenze motors

(According to: Low-Voltage Directive 2006/95/EC)

General

Low-voltage machines have hazardous live and rotating parts and possibly also hot surfaces.

Synchronous machines induce voltages at open terminals during operation.

All operations concerning transport, connections, commissioning and maintenance must be carried out by qualified, skilled personnel (EN 50110-1 (VDE 0105-100) and IEC 60364 must be observed). Inappropriate use creates the risk of severe injury to persons and damage to material assets.

Low-voltage machines may only be operated under the conditions that are indicated in the section "Application as directed".

The conditions at the place of installation must comply with the data given on the nameplate and in the documentation.

Application as directed

Low-voltage machines are intended for commercial installations. They comply with the harmonised standards of the series EN 60034 (VDE 0530). Their use in potentially explosive atmospheres is prohibited unless they are expressly intended for such use (follow additional instructions).

Low-voltage machines are components for installation into machines as defined in the Machinery Directive 98/37/EC. Commissioning is prohibited until the conformity of the end product with this directive has been established (follow i. a. EN 60204-1).

Low-voltage machines with IP23 protection or less are only intended for outdoor use when applying special protective features.

The integrated brakes must not be used as safety brakes. It cannot be ruled out that factors which cannot be influenced, such as oil ingress due to a defective A-side shaft seal, cause a brake torque reduction.

Transport, storage

Damage must be reported immediately to the forwarder upon receipt; if required, commissioning must be excluded. Tighten screwed-in ring bolts before transport. They are designed for the weight of the low-voltage machines, do not apply extra loads. If necessary, use suitable and adequately dimensioned means of transport (e. g. rope guides).

Remove transport locking devices before commissioning. Reuse them for further transport. When storing low-voltage machines, ensure a dry, dust-free and low-vibration ($v_{\text{eff}} \leq 0.2 \text{ mm/s}$) environment (bearing damage while being stored).

Installation

Ensure an even surface, solid foot/flange mounting and exact alignment if a direct clutch is connected. Avoid resonances with the rotational frequency and double mains frequency which may be caused by the assembly. Turn rotor by hand, listen for unusual slipping noises. Check the direction of rotation when the clutch is not active (observe section "Electrical connection").

Use appropriate means to mount or remove belt pulleys and clutches (heating) and cover them with a touch guard. Avoid impermissible belt tensions.

The machines are half-key balanced. The clutch must be half-key balanced, too. The visible jutting out part of the key must be removed.

If required, provide pipe connections. Designs with shaft end at bottom must be protected with a cover which prevents the ingress of foreign particles into the fan. Free circulation of the cooling air must be ensured. The exhaust air - also the exhaust air of other machines next to the drive system - must not be taken in immediately.

Electrical connection

All operations must only be carried out by qualified and skilled personnel on the low-voltage machine at standstill and deenergised and provided with a safe guard to prevent an unintentional restart. This also applies to auxiliary circuits (e. g. brake, encoder, blower).

Check safe isolation from supply!

If the tolerances specified in EN 60034-1; IEC 34 (VDE 0530-1) - voltage $\pm 5\%$, frequency $\pm 2\%$, waveform, symmetry - are exceeded, more heat will be generated and the electromagnetic compatibility will be affected.

Observe the data on the nameplate, operating notes, and the connection diagram in the terminal box.

The connection must ensure a continuous and safe electrical supply (no loose wire ends); use appropriate cable terminals. The connection to the PE conductor must be safe. The plug-in connectors must be bolted tightly (to stop).

The clearances between blank, live parts and to earth must not fall below 8 mm at $U_r \leq 550$ V, 10 mm at $U_r \leq 725$ V, 14 mm at $U_r \leq 1000$ V.

The terminal box must be free of foreign particles, dirt and moisture. All unused cable entries and the box itself must be sealed against dust and water.

Safety instructions

General safety and application instructions for Lenze motors

Commissioning and operation

Before commissioning after longer storage periods, measure insulation resistance. In the case of values $\leq 1 \text{ k}\Omega$ per volt of rated voltage, dry winding.

For trial run without output elements, lock the featherkey. Do not deactivate the protective devices, not even in a trial run.

Check the correct operation of the brake before commissioning low-voltage machines with brakes.

Integrated thermal detectors do not provide full protection for the machine. If necessary, limit the maximum current. Parameterise the controller so that the motor will be switched off with $I > I_r$ after a few seconds of operation, especially at the risk of blocking.

Vibrational severities $v_{\text{eff}} \leq 3.5 \text{ mm/s}$ ($P_r \leq 15 \text{ kW}$) or 4.5 mm/s ($P_r > 15 \text{ kW}$) are acceptable if the clutch is activated.

If deviations from normal operation occur, e.g. increased temperatures, noises, vibrations, find the cause and, if required, contact the manufacturer. In case of doubt, switch off the low-voltage machine.

If the machine is exposed to dirt, clean the air paths regularly.

Shaft sealing rings and roller bearings have a limited service life.

Regrease bearings with relubricating devices while the low-voltage machine is running. Only use the grease recommended by the manufacturer. If the grease drain holes are sealed with a plug, (IP54 drive end; IP23 drive and non-drive end), remove plug before commissioning. Seal bore holes with grease. Replace prelubricated bearings (2Z bearing) after approx. 10,000 h - 20,000 h, at the latest however after 3 - 4 years.

The product-specific safety and application notes given in these instructions must be observed!

2.3 Residual hazards

Protection of persons

- ▶ Before working on the controller, check if no voltage is applied to the power terminals because
 - depending on the device - the power terminals L1, L2/N, L3, U, V, W, +UG, - UG and RB remain live for at least 3 minutes after disconnecting the mains.
 - the power terminals L1, L2/N, L3; U, V, W, +UG, - UG and RB remain live when the motor is stopped.

Device protection

- ▶ Connect/disconnect all pluggable terminals only in deenergised condition!
- ▶ Detach the controllers from the installation, e.g. from the rear panel of the control cabinet, only in deenergised condition!

Motor protection

- ▶ Depending on the controller settings, the connected motor can be overheated by:
 - For instance, longer DC-braking operations.
 - Longer operation of self-ventilated motors at low speed.

Protection of the machine/system

- ▶ Drives can reach dangerous overspeeds (e.g. setting of high output frequencies in connection with motors and machines unsuitable for such conditions):
 - The controllers do not offer any protection against such operating conditions. Use additional components for this purpose.

Parameter set transfer

- ▶ During the parameter set transfer, control terminals of the controllers can adopt undefined states!
 - Therefore it is required to disable the terminal X4 (digital input signals) before the transfer starts. This ensures that the controller is inhibited and all control terminals have the firmly defined "LOW" status.
- ▶ Switch **contactors in the motor cable** only if the controller is inhibited.
When switching contactors in the motor cable while the controller is enabled, you can activate monitoring functions of the controller. If no monitoring function is activated, switching is permissible.

3 Product description

Device features

3 Product description

3.1 Device features

Features	Version	
	BaseLine D	BaseLine C
Power range: 250 W to 3.0 kW	✓	✓
Integrated interference suppression according to EN 61800-3	✓	✓
Dynamic brake transistor integrated in devices with 400 V mains connection	✓	✓
Integrated shield terminal for safe installation of the control cables	✓	✓
Identical connection system for the control cables in the entire power range	✓	✓
System bus connection (CANopen)	-	✓
Memory module for quick commissioning and easy service	✓	✓
Interface for diagnostics and parameter settings, also during operation	✓	✓
Automatic motor identification for optimum operational performance	✓	✓
I ² t motor monitoring	✓	✓
Flying restart circuit for quick and jerk-free flying restart on the motor	✓	✓
DC-current braking function	✓	✓
Freely configurable user menu	✓	✓
Operating modes: <ul style="list-style-type: none"> – VFCplus: V/F open loop, linear and square-law – SLVC: Sensorless vector control (speed) 	✓	✓
S ramps for jerk-free acceleration and deceleration	✓	✓
As option, DC bus terminal: <ul style="list-style-type: none"> • to connect devices operating at 230 V to: <ul style="list-style-type: none"> – an external brake module and/or – a DC bus system or – DC supply (only with devices in the power range 0.25 ... 1.5 kW) • to connect devices operating at 400 V to: <ul style="list-style-type: none"> – an external brake resistor and/or – a DC source or a DC bus system, or – DC supply (with devices in the power range 0.37 ... 3 kW) 	✓	✓



Note!

When the device is operated from a DC source:

- ▶ the internal RFI filter is not active.
- ▶ the device is not UL rated.

3.2 Overview of the devices

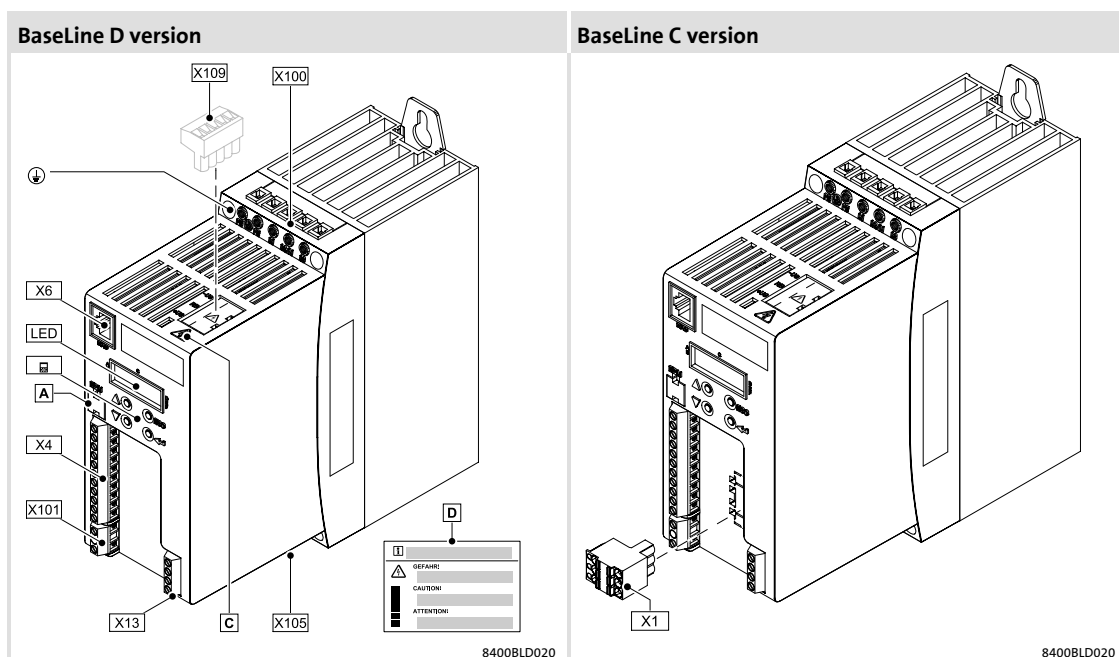

Fig. 3-1 BaseLine version, devices in the power range from 0.25 to 3 kW

Pos.	Description	Information	
		230 V	400 V
A	EPM - Slot for memory module	📖 108	
D	Sticker with warning	📖 43	
X1	System bus connection (CANopen)	📖 74	
X4	Analog input	📖 75	
	10-V reference voltage		
	Digital inputs		
	Controller enable	📖 78	
X6	Digital output		
	Diagnostics	📖 81	
X13	Terminal for I/O shields	-	
X100	Terminal for mains voltage	📖 62	📖 68
X105	Motor terminal	📖 65	📖 70
X109	DC bus terminal (optional, can be ordered as a separate item)	📖 64	📖 69
⊕	PE conductor	-	
📖	Integrated keypad	📖 83	

Icon	Description
⚡	Long discharge time: All power terminals remain live for a few minutes after mains disconnection! The duration is given under the warning symbol on the device.
⚠	High leakage current: Carry out fixed installation and PE connection according to EN 61800-5-1!
⚡	Electrostatic sensitive devices: Before working on the device, the personnel must be free of electrostatic charge!
🔥	Hot surface: Risk of burns! Hot surfaces should not be touched without wearing protective gloves.

3

Product description

Overview of the devices

Determining the device type

3.2.1

Determining the device type

The type data used in this manual refer to the nameplate ① which is placed at the front of the controller and to the nameplate ② placed on the side of the controller (Fig. 3-2).

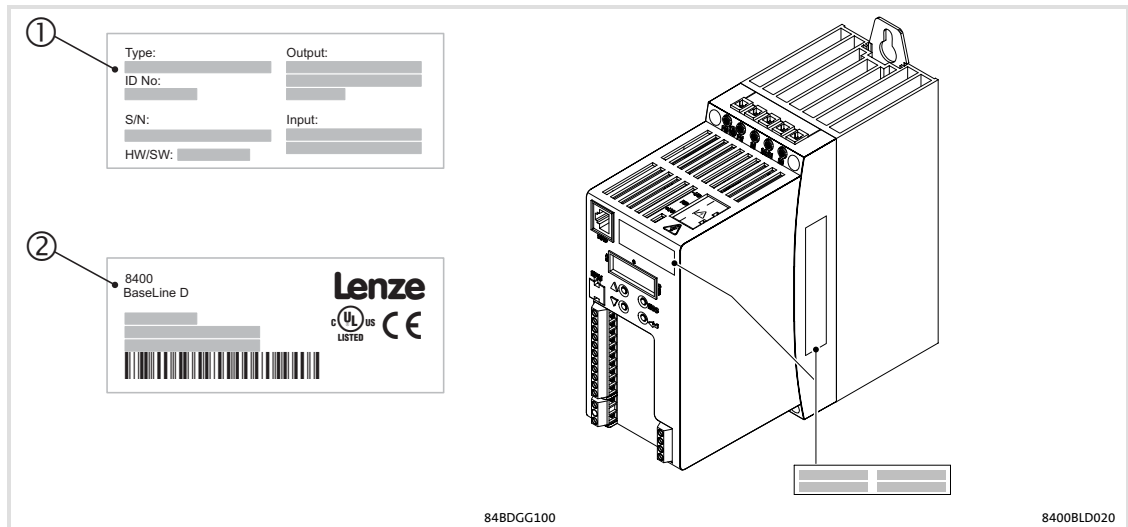

Fig. 3-2 Placement of the nameplates

3.2.2 Type code

	E84	A	V	xx	x	xxx	x	x	X	x
Product range 8400 inverter drives										
Generation A = 1st generation										
Inverter type V = vector-controlled inverter										
Version BC = BaseLine C BD = BaseLine D										
Mounting type E = IP20 D = push-through technique (thermal separation) C = cold-plate technique										
Power e.g. 251 = $25 \times 10^1 \text{ W} = 0.25 \text{ kW}$ 222 = $22 \times 10^2 \text{ W} = 2.2 \text{ kW}$										
Voltage class 2 = 230/240 V 1/N/PE AC (0.25 ... 2.2 kW) 4 = 400/500 V 3/PE AC (0.37 ... 3.0 kW)										
Ambient conditions S = standard										
Safety engineering X = no safety function										
0 = without digital output "DO1" 1 = with digital output "DO1"										

4 Technical data

General data and operating conditions

4 Technical data

4.1 General data and operating conditions

Conformity and approval			
Conformity			
CE	2006/95/EG	Low-Voltage Directive	
Approval			
UL	UL 508C	Devices in the power range from 0.25 to 3 kW: Industrial Control Equipment (IND.CONT.EQ), 5D81, File No. E170350	
Protection of persons and devices			
Enclosure	EN 60529	IP 20	in ready-for-use mounted state
Insulation resistance	EN 61800-5-1	Overvoltage category III above 2000 m amsl: overvoltage category II	
Insulation of control circuits	EN 61800-5-1	Safe mains isolation by double/reinforced insulation. For phase to ground (Earth) voltage < 300 VAC	
Short-circuit strength	EN 61800-5-1	Motor connection: limited, controller is inhibited, error acknowledgement is required Control terminals: full	
Protective measures against		<ul style="list-style-type: none"> • Short circuit • Earth fault • Overvoltage • Motor stalling • Motor overtemperature (thermal contact, I²t monitoring) 	
Leakage current	EN 61800-5-1	> 3.5 mA AC, > 10 mA DC	Observe the regulations and safety instructions!
Cyclic mains switching		Cyclic mains switching at intervals of 3 min is permissible. If the mains are exceptionally switched three times in one minute, a pause of 9 min must follow.	
Starting current		≤ I _N	
Supply conditions			
AC mains operation		Direct connection	
Power systems			
TT		<ul style="list-style-type: none"> • For central grounded systems operation is permitted without restrictions. • For corner grounded 400/500 V systems operation is possible, but reinforced insulation to control circuits is compromised. 	
TN			
DC-bus operation		Direct connection is possible with E84AVBxxxx4 devices Note: When the device is operated from a DC source, the internal RFI filter is not active and the device is not UL rated.	
Motors	EN 60034	Only use motors suitable for inverter operation. Insulation resistance: min. $\dot{u} \geq 1.5$ kV, min. $du/dt \geq 5$ kV/ μ s	

General data and operating conditions

Environmental conditions		
Climate		
Storage	IEC/EN 60721-3-1	1K3 (-25 ... +60 °C)
Transport	IEC/EN 60721-3-2	2K3 (-25 ... +70 °C)
Operation	IEC/EN 60721-3-3	3K3 (-10 ... +55 °C) Operation at 2/4 kHz, +45 ... +55 °C: Operation at 8/16 kHz, +40 ... +55 °C: For operation above +40 ... +45°C, reduce rated output current by 2.5 %/°C
Site altitude		0 ... 4000 m amsl 1000 ... 4000 m amsl: Reduce rated output current by 5 %/1000 m 2000 ... 4000 m amsl: overvoltage category II
Pollution	EN 61800-5-1	Pollution Degree 2
Vibration resistance (9.81 m/s ² = 1 g)		
Transport	IEC/EN 60721-3-2	2M2
	EN 61800-5-1	2 ... 9 Hz: amplitude 3.5 mm
		10 ... 200 Hz: acceleration resistant up to 10 m/s ² 200 ... 500 Hz: acceleration resistant up to 15 m/s ²
Operation	Germanischer Lloyd	5 ... 13,2 Hz: amplitude ±1 mm 13.2 ... 100 Hz: acceleration resistant up to 0.7 g
	EN 61800-5-1	10 ... 57 Hz: amplitude 0.075 mm
		57 ... 150 Hz: acceleration resistant up to 10 m/s ² (1 g)
Requirements on the motor cable		
Capacitance per unit length		
≤ 1.5 mm ² /AWG 16		$C_{\text{Core/core}}/C_{\text{Core/shield}} \leq 75/150 \text{ pF/m}$
≥ 2.5 mm ² /AWG 12		$C_{\text{core/core}}/C_{\text{Core/shield}} \leq 100/\leq 150 \text{ pF/m}$
Electric strength		
	VDE 0250-1	$U_0/U = 0.6/1.0 \text{ kV}$ (U_0 = r.m.s. value - external conductor to PE, U = r.m.s. value - external conductor to external conductor)
	UL	$U \geq 600 \text{ V}$ (U = r.m.s. value - external conductor to external conductor)

Technical data

General data and operating conditions

EMC (when installed and connected per section 5.2)		
Noise emission		
conducted	EN 61800-3	up to 25 m of shielded motor cable: category C2
radiated		Category C2 with proper cable grounding and enclosure
Noise immunity inside grounded enclosure (according to requirements of EN 61800-3)		
Electrostatic discharge (ESD)	EN 61000-4-2	8 kV with air discharge, 4 kV with contact discharge against enclosure
Radio frequency		
conducted	EN 61000-4-6	150 kHz ... 80 MHz, 10 V/m 80 % AM (1kHz)
radiated (enclosure)	EN 61000-4-3	80 MHz ... 1000 MHz, 10 V/m 80 % AM (1kHz)
Burst		
Power terminals and interfaces	EN 61000-4-4	2 kV/5 kHz
Signal interfaces	EN 61000-4-4	1 kV/5 kHz
Control terminals	EN 61000-4-4	2 kV/5 kHz
Surge		
Power terminals	EN 61000-4-5	1.2/50 μ s, 1 kV phase/phase, 2 kV phase/PE
Control terminals	EN 61000-4-5	1.2/50 μ s, 1 kV
Operation on public supply systems	EN 61000-3-2 EN 61000-3-12	The devices are intended for use in an industrial environment. When being used on public network, additional measures must be taken to limit the expected radio interference. The compliance with the requirements for the machine/plant is the responsibility of the manufacturer of the machine or system!
	EN 61000-3-2	< 0.5 kW: with mains choke 0.5 ... 1 kW: with active filter
		> 1 kW at mains current \leq 16 A: No limit values for harmonic currents
	EN 61000-3-12	Mains current > 16 A: further measures are required for compliance with the standard

Control		
Control method		
	VFCplus:	
	<ul style="list-style-type: none"> V/Hz loop (linear or square-law) 	
	SLVC:	
	<ul style="list-style-type: none"> Sensorless vector control (speed) 	
Switching frequency		
	2 kHz, 4 kHz, 8 kHz, 16 kHz, Optionally noise optimised or power loss optimised	
Torque behaviour		
Maximum torque	1.5 x M_N for 60 s 1.8 x M_N for 3 s	if rated motor power = rated controller power
Setting range	1 : 10	In SLVC: <ul style="list-style-type: none"> in the speed range 3 ... 50 Hz In V/f: <ul style="list-style-type: none"> in the speed range 10 ... 50 Hz
Sensorless vector control (speed)		
Minimum output frequency	0.5 Hz (0 ... M_N)	
Setting range	1 : 10	referring to 50 Hz and M_N
Accuracy	±0.5 %	in the speed range 3 ... 50 Hz
Smooth running	±0.1 Hz	
Output frequency		
Range	-300 Hz ... +300 Hz	
Absolute resolution	0.2 Hz	
Standardised resolution	Parameter data: 0.01 %, process data: 0.006 % (= 2 ¹⁴)	
Digital setpoint selection		
Accuracy	±0.01 %	
Analog setpoint selection		
Accuracy	±0.5 %	referring to final value

4 Technical data

Rated data

Overview

4.2 Rated data

4.2.1 Overview

Input data

Basis of the data			
Mains	Voltage U_{LN} [V]	Voltage range U_{LN} [V]	Frequency range f [Hz]
1/N/PE AC	230	180 - 0 % ... 264 + 0 %	45 - 0 % ... 65 + 0 %
3/PE AC	400	320 - 0 % ... 440 + 0 %	45 - 0 % ... 65 + 0 %
3/PE AC	500	400 - 0 % ... 550 + 0 %	45 - 0 % ... 65 + 0 %

Type	Voltage [V]	Frequency [Hz]	Current [A]		Number of phases
			max. +45 °C ^①	max. +55 °C ^①	
E84AVBxx2512	230	50/60	3.4	2.6	1
E84AVBxx3712	230	50/60	5.1	3.8	1
E84AVBxx5512	230	50/60	6.7	5.0	1
E84AVBxx7512	230	50/60	8.8	6.6	1
E84AVBxx1122	230	50/60	12	9.0	1
E84AVBxx1522	230	50/60	13.7	10.3	1
E84AVBxx2222	230	50/60	22.0	18.4	1
E84AVBxx3714	400/500	50/60	1.8/1.5	1.4/1.1	3
E84AVBxx5514	400/500	50/60	2.3/2.0	1.7/1.5	3
E84AVBxx7514	400/500	50/60	3.2/2.7	2.4/2.0	3
E84AVBxx1124	400/500	50/60	4.2/3.6	3.2/2.7	3
E84AVBxx1524	400/500	50/60	4.7/4.1	3.5/3.1	3
E84AVBxx2224	400/500	50/60	6.2/5.4	4.7/4.1	3
E84AVBxx3024	400/500	50/60	10.2/7.8	7.7/5.9	3

^① Ambient temperature in the control cabinet, switching frequency 2 and 4 kHz, operation without mains choke

Output data

Type	Voltage [V]	Frequency [Hz]	Current [A]		Number of phases
			max. +45 °C ①	max. +55 °C ①	
E84AVBxx2512	0-230	0-300	1.7	1.3	3
E84AVBxx3712	0-230	0-300	2.4	1.8	3
E84AVBxx5512	0-230	0-300	3.0	2.3	3
E84AVBxx7512	0-230	0-300	4.0	3.0	3
E84AVBxx1122	0-230	0-300	5.5	4.1	3
E84AVBxx1522	0-230	0-300	7.0	5.3	3
E84AVBxx2222	0-230	0-300	9.5	7.1	3
E84AVBxx3714	0-400/500	0-300	1.3/1.0	1.0/0.8	3
E84AVBxx5514	0-400/500	0-300	1.8/1.4	1.4/1.1	3
E84AVBxx7514	0-400/500	0-300	2.4/1.9	1.8/1.4	3
E84AVBxx1124	0-400/500	0-300	3.2/2.6	2.4/2.0	3
E84AVBxx1524	0-400/500	0-300	3.9/3.1	2.9/2.3	3
E84AVBxx2224	0-400/500	0-300	5.6/4.5	4.2/3.4	3
E84AVBxx3024	0-400/500	0-300	7.3/5.8	5.5/4.4	3

① Temperature in the control cabinet

**Note!**

The indicated output voltage will not be reached under certain operating conditions.

- ▶ Output power in the maximum range
- ▶ High switching frequencies
- ▶ Use of mains filters or mains chokes
- ▶ Mains supply with high impedance ($U_k > 5\%$)

Power losses

Type	Power loss P_V [W]	
	when operating with rated output current I_{aN}	when controller is inhibited
E84AVBxx2512	15	10
E84AVBxx3712	17	
E84AVBxx5512	23	
E84AVBxx7512	30	
E84AVBxx1122	43	14
E84AVBxx1522	54	
E84AVBxx2222	76	
E84AVBxx3714	15	
E84AVBxx5514	22	10
E84AVBxx7514	29	
E84AVBxx1124	42	
E84AVBxx1524	48	
E84AVBxx2224	66	14
E84AVBxx3024	91	

4

Technical data

Rated data

Operation at rated mains voltage 230 V

4.2.2

Operation at rated mains voltage 230 V

Basis of the data				
Mains	Voltage U_{LN} [V]	Voltage range U_{LN} [V]		Frequency range f [Hz]
1/N/PE AC	230	180 - 0 % ... 264 + 0 %		45 - 0 % ... 65 + 0 %

Type	Mains current at I_{aN}		Output power	Motor power
	with external mains choke I_{LN} [A]	without external mains choke I_{LN} [A]	U, V, W S_{aN} [kVA]	4 pol. ASM P_{aN} [kW]
E84AVBxx2512	3.0	3.4	0.6	0.25
E84AVBxx3712	4.2	5.1	0.9	0.37
E84AVBxx5512	5.4	6.7	1.1	0.55
E84AVBxx7512	7.0	8.8	1.4	0.75
E84AVBxx1122	9.9	12.0	2.0	1.1
E84AVBxx1522	11.8	13.7	2.5	1.5
E84AVBxx2222	15.7	22.0	3.4	2.2

Assignment	
Type	Mains choke
E84AVBxx2512	ELN1-0900H005
E84AVBxx3712	
E84AVBxx5512	ELN1-0500H009
E84AVBxx7512	
E84AVBxx1122	ELN1-0250H018
E84AVBxx1522	
E84AVBxx2222	

Type	Output currents [A] at switching frequency							
	2 kHz		4 kHz		8 kHz		16 kHz	
	I_{aN2}	I_{aM2}	I_{aN4}	I_{aM4}	I_{aN8}	I_{aM8}	I_{aN16}	I_{aM16}
E84AVBxx2512	1.7	3.4	1.7	3.4	1.7	3.4	1.1	2.2
E84AVBxx3712	2.4	4.8	2.4	4.8	2.4	4.8	1.6	3.2
E84AVBxx5512	3.0	6.0	3.0	6.0	3.0	6.0	2.0	4.0
E84AVBxx7512	4.0	8.0	4.0	8.0	4.0	8.0	2.7	5.4
E84AVBxx1122	5.5	11.0	5.5	11.0	5.5	11.0	3.7	7.4
E84AVBxx1522	7.0	14.0	7.0	14.0	7.0	14.0	4.7	9.4
E84AVBxx2222	9.5	19.0	9.5	19.0	9.5	19.0	6.3	12.6

 I_{aNx} I_{aMx}

Switching frequency

Rated value - continuous output current

Maximum output current (overload current)

- Periodic load change of 3 s with I_{aMx} and recovery time of 12 s with 75 % I_{aNx}
- Can be achieved with the setting "x kHz fixed/..." in C00018

When the maximum heatsink temperature is reached, the switching frequency is reduced to 4 kHz.

With the setting "x kHz var./..." in C00018, the switching frequency is reduced dynamically.

- At 16 kHz and $I_a > 100\% \times I_{aN8}$ to 8 kHz
- At 8 kHz and $I_a > 150\% \times I_{aN8}$ to 4 kHz

Fuses and cable cross-sections

Operation without external mains choke/mains filter								
Type	Installation according to EN 60204-1 ¹⁾					Installation according to UL ²⁾		FI ³⁾ [mA]
	①	②	L1, N - laying system			③	L1, N	
			B2	C	F			
[A]	[A]	[mm ²]	[mm ²]	[mm ²]	[A]	[AWG]		
E84AVBxx2512	C10	10	1.5	-	-	10	14	≥ 30
E84AVBxx3712	C10	10	1.5	-	-	10	14	
E84AVBxx5512	C16	16	1.5	-	-	12	14	
E84AVBxx7512	C16	16	1.5	-	-	15	14	
E84AVBxx1122	C20	20	2.5	-	-	20	12	
E84AVBxx1522	C25	25	4 ⁴⁾	-	-	20	10	
E84AVBxx2222	C32	32	6 ⁴⁾	-	-	35	10	

1) These values are recommendations only. Other dimensioning values/laying systems are possible (e.g. according to VDE 0298-4).

The cable-cross sections apply under the following conditions: Use of PVC-insulated copper cables, conductor temperature < 70 °C, ambient temperature < 45 °C, no bundling of cables or cores, two loaded cores. Smaller cable cross-sections are not permissible for technical reasons.

2) Use UL-approved cable, fuses, and fuse holders only.

UL fuse: voltage ≥ 240 V, tripping characteristic "H", "K5" or "CC".

The cable cross-sections apply under the following conditions: conductor temperature < 75 °C, ambient temperature < 45 °C. Smaller cable cross-sections are not permissible for technical reasons.

3) Pulse-current sensitive or universal-current sensitive earth-leakage circuit breaker, short-time delay

If cables are longer than 50 m, the protective circuit-breaker may respond, depending on the cable type and switching frequency.

4) only with pin-end connector

① Circuit breaker

② Fuse

③ Fuse

Observe national and regional regulations

4

Technical data

Rated data

Operation at rated mains voltage 230 V

Operation with external mains choke/mains filter								
Type	Installation according to EN 60204-1 ¹⁾					Installation according to UL ²⁾		FI ³⁾ [mA]
	①	②	L1, N - laying system			③	L1, N	
			B2	C	F			
	[A]	[A]	[mm ²]	[mm ²]	[mm ²]	[A]	[AWG]	
E84AVBxx2512	C6	6	1.5	-	-	10	14	≥ 30
E84AVBxx3712	C6	6	1.5	-	-	10	14	
E84AVBxx5512	C10	10	1.5	-	-	10	14	
E84AVBxx7512	C10	10	1.5	-	-	10	14	
E84AVBxx1122	C16	16	1.5	-	-	15	14	
E84AVBxx1522	C20	20	2.5	-	-	20	12	
E84AVBxx2222	C25	25	4 ⁴⁾	-	-	25	10	

1) These values are recommendations only. Other dimensioning values/laying systems are possible (e.g. according to VDE 0298-4).

The cable-cross sections apply under the following conditions: Use of PVC-insulated copper cables, conductor temperature < 70 °C, ambient temperature < 45°C, no bundling of cables or cores, two loaded cores. Smaller cable cross-sections are not permissible for technical reasons.

2) Use UL-approved cable, fuses, and fuse holders only.

UL fuse: voltage ≥ 240 V, tripping characteristic "H", "K5" or "CC".

The cable cross-sections apply under the following conditions: conductor temperature < 75 °C, ambient temperature < 45°C. Smaller cable cross-sections are not permissible for technical reasons.

3) Pulse-current sensitive or universal-current sensitive earth-leakage circuit breaker, short-time delay

If cables are longer than 50 m, the protective circuit-breaker may respond, depending on the cable type and switching frequency.

4) only with pin-end connector

① Circuit breaker

② Fuse

③ Fuse

Observe national and regional regulations

4.2.3 Operation at rated mains voltage 400 V

Basis of the data			
Mains	Voltage U_{LN} [V]	Voltage range U_{LN} [V]	Frequency range f [Hz]
3/PE AC	400	320 - 0 % ... 440 + 0 %	45 - 0 % ... 65 + 0 %

Type	Mains current at I_{aN}		Output power	Motor power
	with external mains choke	without external mains choke	U, V, W S_{aN} [kVA]	4 pol. ASM P_{aN} [kW]
	I_{LN} [A]	I_{LN} [A]		
E84AVBxx3714	1.4	1.8	0.8	0.37
E84AVBxx5514	1.8	2.3	1.2	0.55
E84AVBxx7514	2.2	3.2	1.6	0.75
E84AVBxx1124	3.2	4.2	2.1	1.1
E84AVBxx1524	3.6	4.7	2.5	1.5
E84AVBxx2224	5.0	6.2	3.6	2.2
E84AVBxx3024	7.1	10.2	4.8	3.0

Assignment	
Type	Mains choke
E84AVBxx3714	ELN3-1500H003-001
E84AVBxx5514	
E84AVBxx7514	
E84AVBxx1124	ELN3-0680H006-001
E84AVBxx1524	
E84AVBxx2224	
E84AVBxx3024	ELN3-0250H013-001

Technical data

Rated data

Operation at rated mains voltage 400 V

Alternative DC supply

Basis of the data			
Mains	Voltage U_{DC} [V]	Voltage range U_{DC} [V]	Frequency range f [Hz]
2/PE DC	565	455 - 0 % ... 620 + 0 %	-

Type	Input current at I_{aN} I_{DC} [A]	Output power U, V, W S_{aN} [kVA]	Motor power 4.pol. ASM P_{aN} [kW]
E84AVBxx3714	2.2	0.8	0.37
E84AVBxx5514	2.8	1.1	0.55
E84AVBxx7514	3.6	1.5	0.75
E84AVBxx1124	5.1	2.0	1.1
E84AVBxx1524	5.8	2.4	1.5
E84AVBxx2224	7.6	3.5	2.2
E84AVBxx3024	10.0	4.6	3.0



Note!

When the device is operated from a DC source:

- ▶ the internal RFI filter is not active.
- ▶ the device is not UL rated.

Type	Output currents [A] at switching frequency							
	2 kHz		4 kHz		8 kHz		16 kHz	
	I_{aN2}	I_{aM2}	I_{aN4}	I_{aM4}	I_{aN8}	I_{aM8}	I_{aN16}	I_{aM16}
E84AVBxx3714	1.3	2.3	1.3	2.3	1.3	2.3	0.9	1.8
E84AVBxx5514	1.8	3.2	1.8	3.2	1.8	3.2	1.2	2.4
E84AVBxx7514	2.4	4.2	2.4	4.2	2.4	4.2	1.6	3.2
E84AVBxx1124	3.2	5.6	3.2	5.6	3.2	5.6	2.1	4.2
E84AVBxx1524	3.9	6.8	3.9	6.8	3.9	6.8	2.6	5.2
E84AVBxx2224	5.6	9.8	5.6	9.8	5.6	9.8	3.7	7.4
E84AVBxx3024	7.3	12.4	7.3	12.4	7.3	12.4	4.9	9.8

 I_{aNx} I_{aMx}

Switching frequency

Rated value - continuous output current

Maximum output current (overload current)

- Periodic load change of 3 s with I_{aMx} and recovery time of 12 s with 75 % I_{aNx}
- Can be achieved with the setting "x kHz fixed/..." in C00018

When the maximum heatsink temperature is reached, the switching frequency is reduced to 4 kHz.

With the setting "x kHz var./..." in C00018, the switching frequency is reduced dynamically.

- At 16 kHz and $I_a > 100\% \times I_{aN8}$ to 8 kHz
- At 8 kHz and $I_a > 150\% \times I_{aN8}$ to 4 kHz

Rated data for internal brake chopper

Switching threshold V_{BRmax} : 725 V, adjustable

Type	R_{Bmin} [Ω]	I_{BRmax} [A]	P_{BRmax} [kW]	I_{BRd} [A]	P_{Bd} [kW]	t_z [s]	t_{on} [s]	t_{fp} [s]
E84AVBxx3714	390	1.9	1.3	1.9	1.3	-	∞	-
E84AVBxx5514	390	1.9	1.3	1.9	1.3	-	∞	-
E84AVBxx7514	390	1.9	1.3	1.9	1.3	-	∞	-
E84AVBxx1124	180	4.0	2.9	4.0	2.9	-	∞	-
E84AVBxx1524	180	4.0	2.9	4.0	2.9	-	∞	-
E84AVBxx2224	150	4.8	3.5	4.8	3.5	-	∞	-
E84AVBxx3024	100	7.3	5.3	7.3	5.3	-	∞	-

 R_{Bmin} I_{BRmax} P_{BRmax} I_{BRd} P_{Bd} t_z t_{on} $t_z - t_{on}$ t_{fp} Minimum brake resistance, nominal value $\pm 10\%$

Peak current

Peak braking power

Continuous current RMS - important for cable dimensioning

Continuous braking power

Cycle time, periodic load change with running time and recovery time

Running time in a cycle without reducing the scanning ratio (∞ = no time limit)

Recovery time

Maximum running time without initial load and observing the recovery time

Technical data

Rated data

Operation at rated mains voltage 400 V

Fuses and cable cross-sections

Operation without external mains choke/mains filter								
Type	Installation according to EN 60204-1 ¹⁾					Installation according to UL ²⁾		FI ³⁾ [mA]
	①	②	L1, L2, L3 - Laying system			③	L1, L2, L3	
	[A]	[A]	B2 [mm ²]	C [mm ²]	F [mm ²]	[A]	[AWG]	
E84AVBxx3714	C6	6	1.5	-	-	10	14	≥ 30
E84AVBxx5514	C6	6	1.5	-	-	10	14	
E84AVBxx7514	C6	6	1.5	-	-	10	14	
E84AVBxx1124	C10	10	1.5	-	-	10	14	
E84AVBxx1524	C10	10	1.5	-	-	10	14	
E84AVBxx2224	C10	10	1.5	-	-	10	14	
E84AVBxx3024	C16	16	1.5	-	-	15	14	

1) These values are recommendations only. Other dimensioning values/laying systems are possible (e.g. according to VDE 0298-4). The cable cross-sections apply under the following conditions: Use of PVC-insulated copper cables, conductor temperature < 70 °C, ambient temperature < 45°C, no bundling of cables or cores, three loaded cores.

2) Use UL-approved cables, fuses and fuse holders only.

UL fuse: voltage ≥ 500 V, tripping characteristic "H", "K5" or "CC". The cable cross-sections apply under the following conditions: conductor temperature < 75 °C, ambient temperature < 45°C.

3) Universal-current sensitive earth-leakage circuit breaker, short-time delay

If cables are longer than 50 m, the protective circuit-breaker may respond, depending on the cable type and switching frequency.

① Circuit breaker

② Fuse

③ Fuse

Observe national and regional regulations

Operation with external mains choke/mains filter								
Type	Installation according to EN 60204-1 ¹⁾					Installation according to UL ²⁾		FI ³⁾ [mA]
	①	②	L1, L2, L3 - Laying system			③	L1, L2, L3	
	[A]	[A]	B2 [mm ²]	C [mm ²]	F [mm ²]	[A]	[AWG]	
E84AVBxx3714	C6	6	1.5	-	-	10	14	≥ 30
E84AVBxx5514	C6	6	1.5	-	-	10	14	
E84AVBxx7514	C6	6	1.5	-	-	10	14	
E84AVBxx1124	C10	10	1.5	-	-	10	14	
E84AVBxx1524	C10	10	1.5	-	-	10	14	
E84AVBxx2224	C10	10	1.5	-	-	10	14	
E84AVBxx3024	C16	16	1.5	-	-	12	14	

1) These values are recommendations only. Other dimensioning values/laying systems are possible (e.g. according to VDE 0298-4). The cable cross-sections apply under the following conditions: Use of PVC-insulated copper cables, conductor temperature < 70 °C, ambient temperature < 45°C, no bundling of cables or cores, three loaded cores.

2) Use UL-approved cables, fuses and fuse holders only.

UL fuse: voltage ≥ 500 V, tripping characteristic "H", "K5" or "CC". The cable cross-sections apply under the following conditions: conductor temperature < 75 °C, ambient temperature < 45°C.

3) Universal-current sensitive earth-leakage circuit breaker, short-time delay

If cables are longer than 50 m, the protective circuit-breaker may respond, depending on the cable type and switching frequency.

① Circuit breaker

② Fuse

③ Fuse

Observe national and regional regulations

4.2.4 Operation at rated mains voltage 500 V

Basis of the data			
Mains	Voltage U_{LN} [V]	Voltage range U_{LN} [V]	Frequency range f [Hz]
3/PE AC	500	400 - 0 % ... 550 + 0 %	45 - 0 % ... 65 + 0 %

Type	Mains current at I_{aN}		Output power U, V, W S_{aN} [kVA]	Motor power 4 pol. ASM P_{aN} [kW]
	with external mains choke I_{LN} [A]	without external mains choke I_{LN} [A]		
E84AVBxx3714	1.1	1.5	0.8	0.37
E84AVBxx5514	1.5	2.0	1.1	0.55
E84AVBxx7514	1.9	2.7	1.5	0.75
E84AVBxx1124	2.5	3.6	2.0	1.1
E84AVBxx1524	3.2	4.1	2.4	1.5
E84AVBxx2224	4.3	5.4	3.5	2.2
E84AVBxx3024	5.7	7.2	4.5	3.0

Assignment	
Type	Mains choke
E84AVBxx3714	ELN3-1500H003-001
E84AVBxx5514	
E84AVBxx7514	
E84AVBxx1124	ELN3-0680H006-001
E84AVBxx1524	
E84AVBxx2224	
E84AVBxx3024	

Alternative DC supply

Basis of the data			
Mains	Voltage U_{DC} [V]	Voltage range U_{DC} [V]	Frequency range f [Hz]
2/PE DC	705	565 - 0 % ... 775 + 0 %	-

Type	Input current at I_{aN} I_{DC} [A]	Output power U, V, W S_{aN} [kVA]	Motor power 4.pol. ASM P_{aN} [kW]
E84AVBxx3714	1.8	0.8	0.37
E84AVBxx5514	2.4	1.1	0.55
E84AVBxx7514	3.1	1.5	0.75
E84AVBxx1124	4.4	2.0	1.1
E84AVBxx1524	5.0	2.4	1.5
E84AVBxx2224	6.6	3.5	2.2
E84AVBxx3024	8.6	4.5	3.0

Technical data

Rated data

Operation at rated mains voltage 500 V

Type	Output currents [A] at switching frequency							
	2 kHz		4 kHz		8 kHz		16 kHz	
	I_{aN2}	I_{aM2}	I_{aN4}	I_{aM4}	I_{aN8}	I_{aM8}	I_{aN16}	I_{aM16}
E84AVBxx3714	1.0	2.0	1.0	2.0	1.0	2.0	0.7	1.4
E84AVBxx5514	1.4	2.8	1.4	2.8	1.4	2.8	0.9	1.8
E84AVBxx7514	1.9	3.8	1.9	3.8	1.9	3.8	1.3	2.6
E84AVBxx1124	2.6	5.2	2.6	5.2	2.6	5.2	1.7	3.4
E84AVBxx1524	3.1	6.2	3.1	6.2	3.1	6.2	2.1	4.2
E84AVBxx2224	4.5	9.0	4.5	9.0	4.5	9.0	3.0	6.0
E84AVBxx3024	5.8	11.6	5.8	11.6	5.8	11.6	3.9	7.8

I_{aNx}

I_{aMx}

Switching
frequency

Rated value - continuous output current

Maximum output current (overload current)

- Periodic load change of 3 s with I_{aMx} and recovery time of 12 s with 75 % I_{aNx}
- Can be achieved with the setting "x kHz fixed/..." in C00018

When the maximum heatsink temperature is reached, the switching frequency is reduced to 4 kHz.

With the setting "x kHz var./..." in C00018, the switching frequency is reduced dynamically.

- At 16 kHz and $I_a > 100\% \times I_{aN8}$ to 8 kHz
- At 8 kHz and $I_a > 150\% \times I_{aN8}$ to 4 kHz

Rated data for internal brake chopper

Switching threshold V_{BRmax} : 790 V, adjustable

Type	R_{Bmin} [Ω]	I_{BRmax} [A]	P_{BRmax} [kW]	I_{BRd} [A]	P_{Bd} [kW]	t_z [s]	t_{on} [s]	t_{fp} [s]
E84AVBxx3714	390	2.0	1.6	2.0	1.6	-	∞	-
E84AVBxx5514	390	2.0	1.6	2.0	1.6	-	∞	-
E84AVBxx7514	390	2.0	1.6	2.0	1.6	-	∞	-
E84AVBxx1124	180	4.4	3.5	4.4	3.5	-	∞	-
E84AVBxx1524	180	4.4	3.5	4.4	3.5	-	∞	-
E84AVBxx2224	150	5.3	4.2	5.3	4.2	-	∞	-
E84AVBxx3024	100	7.9	6.2	7.9	6.2	-	∞	-

R_{Bmin}

I_{BRmax}

P_{BRmax}

I_{BRd}

P_{Bd}

t_z

t_{on}

$t_z - t_{on}$

t_{fp}

Minimum brake resistance, nominal value $\pm 10\%$

Peak current

Peak braking power

Continuous current RMS - important for cable dimensioning

Continuous braking power

Cycle time, periodic load change with running time and recovery time

Running time in a cycle without reducing the scanning ratio (∞ = no time limit)

Recovery time

Maximum running time without initial load and observing the recovery time

Fuses and cable cross-sections

Operation without external mains choke/mains filter								
Type	Installation according to EN 60204-1 ¹⁾					Installation according to UL ²⁾		FI ³⁾ [mA]
	①	②	L1, L2, L3 - Laying system			③	L1, L2, L3	
	[A]	[A]	B2 [mm ²]	C [mm ²]	F [mm ²]	[A]	[AWG]	
E84AVBxx3714	C6	6	1.5	-	-	10	14	≥ 30
E84AVBxx5514	C6	6	1.5	-	-	10	14	
E84AVBxx7514	C6	6	1.5	-	-	10	14	
E84AVBxx1124	C10	10	1.5	-	-	10	14	
E84AVBxx1524	C10	10	1.5	-	-	10	14	
E84AVBxx2224	C10	10	1.5	-	-	10	14	
E84AVBxx3024	C16	16	1.5	-	-	12	14	

1) These values are recommendations only. Other dimensioning values/laying systems are possible (e.g. according to VDE 0298-4). The cable cross-sections apply under the following conditions: Use of PVC-insulated copper cables, conductor temperature < 70 °C, ambient temperature < 45°C, no bundling of cables or cores, three loaded cores.

2) Use UL-approved cables, fuses and fuse holders only.

UL fuse: voltage ≥ 500 V, tripping characteristic "H", "K5" or "CC". The cable cross-sections apply under the following conditions: conductor temperature < 75 °C, ambient temperature < 45°C.

3) Universal-current sensitive earth-leakage circuit breaker, short-time delay

If cables are longer than 50 m, the protective circuit-breaker may respond, depending on the cable type and switching frequency.

① Circuit breaker

② Fuse

③ Fuse

Observe national and regional regulations

Operation with external mains choke/mains filter								
Type	Installation according to EN 60204-1 ¹⁾					Installation according to UL ²⁾		FI ³⁾ [mA]
	①	②	L1, L2, L3 - Laying system			③	L1, L2, L3	
	[A]	[A]	B2 [mm ²]	C [mm ²]	F [mm ²]	[A]	[AWG]	
E84AVBxx3714	C6	6	1.5	-	-	10	14	≥ 30
E84AVBxx5514	C6	6	1.5	-	-	10	14	
E84AVBxx7514	C6	6	1.5	-	-	10	14	
E84AVBxx1124	C6	6	1.5	-	-	10	14	
E84AVBxx1524	C10	10	1.5	-	-	10	14	
E84AVBxx2224	C10	10	1.5	-	-	10	14	
E84AVBxx3024	C16	16	1.5	-	-	12	14	

1) These values are recommendations only. Other dimensioning values/laying systems are possible (e.g. according to VDE 0298-4). The cable cross-sections apply under the following conditions: Use of PVC-insulated copper cables, conductor temperature < 70 °C, ambient temperature < 45°C, no bundling of cables or cores, three loaded cores.

2) Use UL-approved cables, fuses and fuse holders only.

UL fuse: voltage ≥ 500 V, tripping characteristic "H", "K5" or "CC". The cable cross-sections apply under the following conditions: conductor temperature < 75 °C, ambient temperature < 45°C.

3) Universal-current sensitive earth-leakage circuit breaker, short-time delay

If cables are longer than 50 m, the protective circuit-breaker may respond, depending on the cable type and switching frequency.

① Circuit breaker

② Fuse

③ Fuse

Observe national and regional regulations

4

Technical data

Overcurrent operation

Operation at rated mains voltage 500 V

4.3

Overcurrent operation

The controllers are designed for a time-limited overcurrent. The "Ixt" protective function protects the controller against impermissible overloads. The protective function monitors the output current within two different time periods.

Definition of the cycles:

- ▶ 15-s cycle ①
 - 3 s load period with peak current **A**
 - 12 s recovery time with limited current **B**
- ▶ 180-s cycle ②
 - 60 s load period with peak current **C**
 - 120 s recovery time with limited current **D**

A load period with peak current must be followed by a recovery time. During the recovery time, the current must not exceed the given value. The utilisation detected in the cycles must not exceed 100% I_{aN8} , otherwise a warning signal is displayed.

The given values refer to the rated output current I_{aN8} .

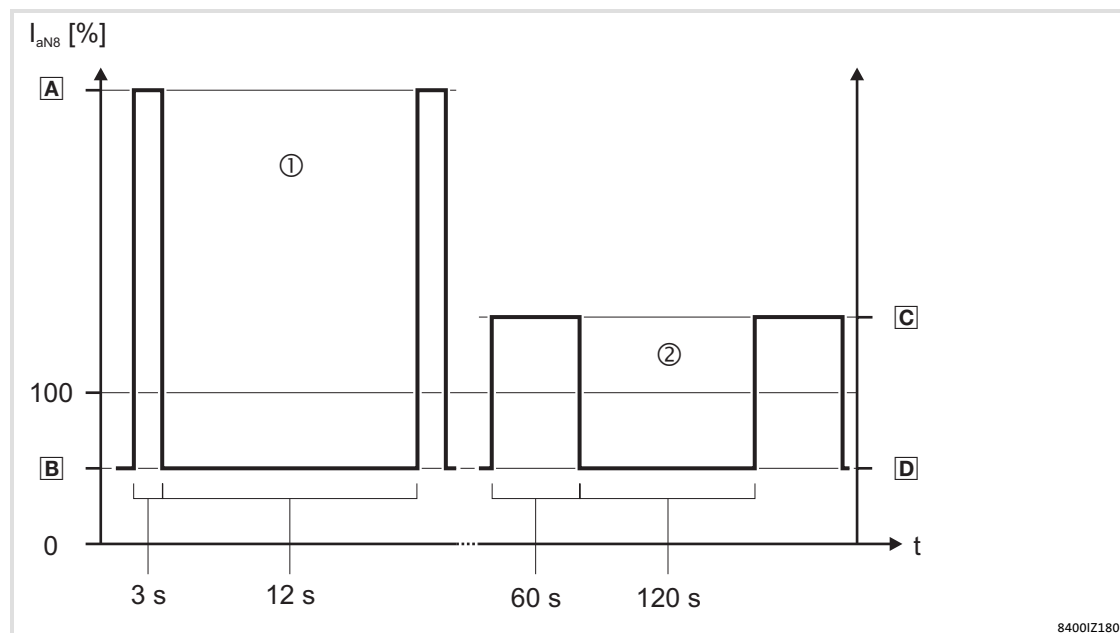

Fig. 4-1 Overcurrent capacity in 230/400 V operation at 45° C

- | | | |
|----------|---|---------------|
| A | Peak current for 3 s | ① 15-s cycle |
| B | max. current in recovery time for 12 s | |
| C | Peak current for 60 s | ② 180-s cycle |
| D | max. current in recovery time for 120 s | |

4.3.1 Device overload for 15-s cycle

Operation at rated mains voltage 230 V

Type	I_{amax}/I_{aN8} [%] in 15-s cycle ①							
	f = 2 kHz		f = 4 kHz		f = 8 kHz		f = 16 kHz	
	A	B	A	B	A	B	A	B
E84AVBxx2512	200	75	200	75	200	75	133	50
E84AVBxx3712								
E84AVBxx5512								
E84AVBxx7512								
E84AVBxx1122								
E84AVBxx1522								
E84AVBxx2222								

Operation at rated mains voltage 400 V

Type	I_{amax}/I_{aN8} [%] in 15-s cycle ①							
	f = 2 kHz		f = 4 kHz		f = 8 kHz		f = 16 kHz	
	A	B	A	B	A	B	A	B
E84AVBxx3714	175	80	175	80	175	80	133	50
E84AVBxx5514								
E84AVBxx7514								
E84AVBxx1124								
E84AVBxx1524								
E84AVBxx2224								
E84AVBxx3024	170	80	170	80	170	80	133	50

Operation at rated mains voltage 500 V

Type	I_{amax}/I_{aN8} [%] in 15-s cycle ①							
	f = 2 kHz		f = 4 kHz		f = 8 kHz		f = 16 kHz	
	A	B	A	B	A	B	A	B
E84AVBxx3714	200	75	200	75	200	75	133	50
E84AVBxx5514								
E84AVBxx7514								
E84AVBxx1124								
E84AVBxx1524								
E84AVBxx2224								
E84AVBxx3024								

4

Technical data

Overcurrent operation

Device overload for 180-s cycle

4.3.2

Device overload for 180-s cycle**Operation at rated mains voltage 230/400 V**

Type	I_{amax}/I_{aN8} [%] in 180-s cycle ②							
	f = 2 kHz		f = 4 kHz		f = 8 kHz		f = 16 kHz	
	C	D	C	D	C	D	C	D
E84AVBxx251x	150	75	150	75	150	75	100	50
E84AVBxx371x								
E84AVBxx551x								
E84AVBxx751x								
E84AVBxx112x	150	75	150	75	150	75	100	50
E84AVBxx152x								
E84AVBxx222x								
E84AVBxx302x	150	75	150	75	150	75	100	50

**Tip!**

For calculations of application-specific cycles please contact your Lenze contact person.

4.4 Terminal description

4.4.1 Overview

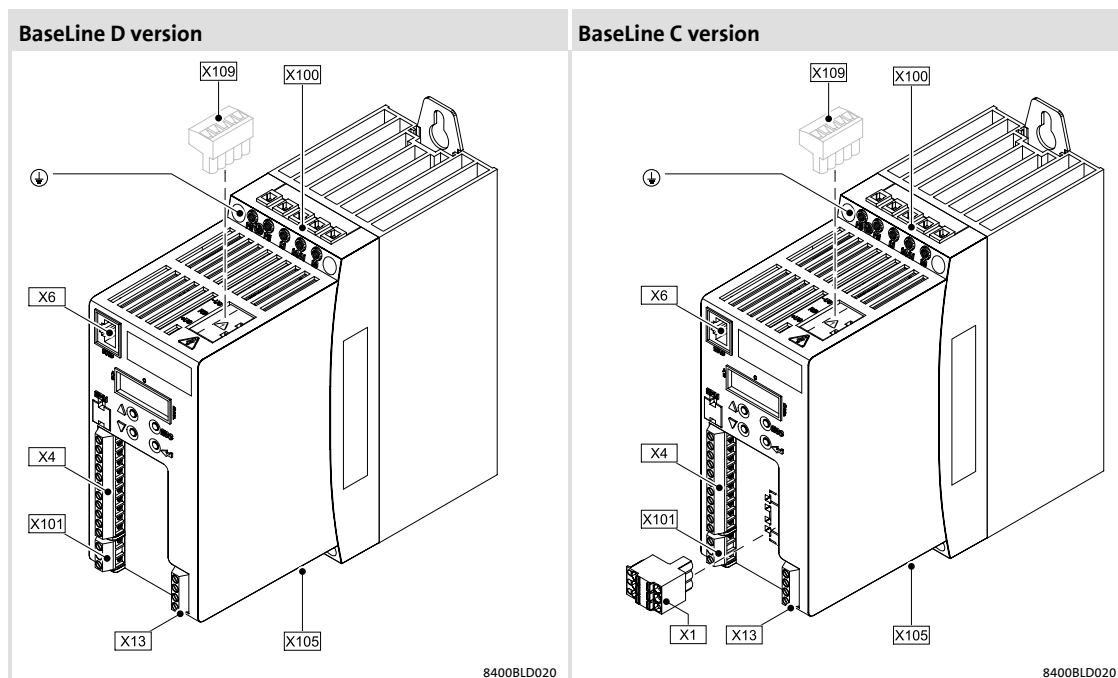

Fig. 4-2 BaseLine version, devices in the power range from 0.25 to 3 kW

Pos.	Description	Number
X1	System bus (CANopen)	1
	Analog input	1
	10-V reference voltage	1
X4	Digital inputs	4
	Controller enable	1
	Digital output	1
	24 V external supply input	1
X13	Terminal for I/O shields	1
X100	Terminal for mains voltage	1
X101	Relay output terminal	1
X105	Motor terminal	1
X109	DC bus terminal (optional, can be ordered as a separate item)	1
⊕	PE conductor	4

4

Technical data

Control terminals

External supply voltage 24 V

4.5

Control terminals

4.5.1

External supply voltage 24 V

Labelling	Feature	Rated value
24E GND	Connection for external 24 V supply voltage	24 V in accordance with IEC 61131-2 15.0 ... 30.0 V Residual ripple max. \pm 5 % SELV/PELV
	Polarity reversal protection	When polarity is reversed the internal 12 V supply is active; no destruction.
	Current consumption	Approx. 50 mA during operation

Labelling	Feature	Rated value
12I	12-V voltage output to connect digital inputs via potential-free contacts	Internal supply: DC
	Max. output current	50 mA
	Electric strength of external voltage	+30 V
	Excess current release	Automatically resettable

4.5.2 Analog input

Labelling	Feature	Rated value
A1U GND	Input	0 ... +10 V with DC voltage
		0 ... +5 V DC (0 ... +20 mA)
		1 ... +5 V DC (+4 ... +20 mA)
	Input resistance	> 50 k Ω with DC voltage 250 Ω (external) with DC current
	Input voltage in case of open circuit	Display "0" (U < 0.2 V, absolute)
	Sampling frequency	1 kHz (1 ms)
	Accuracy	\pm 0.1 V
	Electric strength of external voltage	\pm 15 V, permanent
A/D converter	10 bit resolution Error 1 digit = 0.1 % with regard to final value	

4 Technical data

Control terminals

Digital inputs

4.5.3 Digital inputs

Labelling	Features	Rated value
DI1, DI2	Digital input 1/2	according to IEC61131-2, type 1
DI3, DI4	Digital input 3/4	according to IEC61131-2, type 1
RFR	Controller inhibit	according to IEC61131-2, type 1
	Input resistance	3.3 kΩ (2.0 kΩ ... 5.0 kΩ)
	Electric strength of external voltage	+10 ... +30 V DC, permanent
	Level	LOW = 0 ... +2.5 V DC HIGH = +10 ... 30 V DC
	Cycle time	1 ms
	Isolation	 47

4.5.4 Digital outputs

Labelling	Features	Rated value
DO1	Digital output	In accordance with IEC61131-2, type 1, max. 50 mA
GND	External-voltage protected	Up to +30 V Integrated polarity reversal protection diode for switching inductive loads
	Isolation	 47
	Level	LOW < +5 V HIGH > +15 V
	Behaviour during overload	Reduced voltage or periodical switch-off/on
	Behaviour during reset and switch-on	Outputs are switched off (LOW)
	Cycle time	1 ms

4.5.5 Relay output connection

Labelling	Description/features	Rated value
COM	Central contact of relay	AC 250 V, 3 A
NO	NO contact (normally open)	DC 24 V, 2 A DC 240 V, 0.22 A



Note!

- ▶ The minimum load of the switching contacts should not fall below 12 V and 5 mA.
- ▶ To avoid premature contact wear caused by erosion, a protective circuit (free-wheeling diode, varistor, RC filter or RCD filter) is required, especially in case of inductive load.

5 Mechanical installation

5.1 Important notes



Danger!

Sticker with warning note must be displayed prominently and close to the device!



Note!

The devices must be installed in housings (e.g. control cabinets) to meet applicable regulations.

- ▶ If the cooling air is polluted (lint, (conductive) dust, soot, aggressive gases), take adequate countermeasures, as e.g.:
 - Separate air guide
 - Installation of filters
 - Regular cleaning of the filters
- ▶ Possible mounting position:
 - Vertical on the mounting plate (mains connections at the top, motor connection at the bottom)
- ▶ Maintain the specified free spaces above and below the controller to other installations!
 - Ensure unimpeded ventilation of cooling air and outlet of exhaust air.
 - You can install several controllers of the 8400 L-force Inverter Drives product range next to each other without any clearance in the control cabinet.
- ▶ The mounting plate of the control cabinet must be electrically conductive.
- ▶ In case of continuous vibrations or shocks use vibration dampers.

5 Mechanical installation

Standard devices in the power range from 0.25 ... 3 kW
 Assembly in built-in technique (standard)

5.2 Standard devices in the power range from 0.25 ... 3 kW

5.2.1 Assembly in built-in technique (standard)

For mounting, use two screws M5 x >10 mm. The mounting location and material must ensure a durable mechanical connection.

- Screw and washer assemblies or hexagon socket screws with washers are recommended.

How to proceed:

1. Prepare the fixing holes on the mounting surface.
2. Screw the controller directly to the mounting surface.

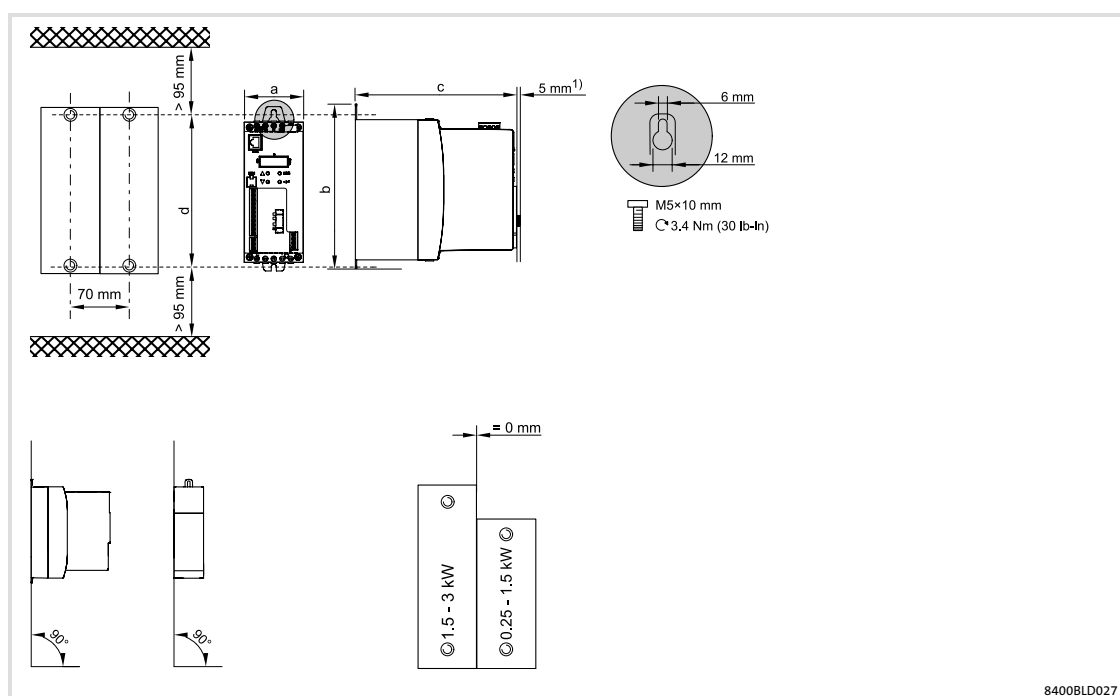



Fig. 5-1 Assembly in "standard" technique

1) BaseLine C

	[kW]	a [mm]	b [mm]	c [mm]	d [mm]	 [kg]
E84AVBxE2512	0.25 ... 0.37	70	194	144	180	1.2
E84AVBxE3712				162 ²⁾		
E84AVBxE3714	0.37 ... 0.75	70	194	162	180	1.2
E84AVBxE551x						
E84AVBxE751x	1.1 ... 1.5	70	194	162	180	1.4
E84AVBxE112x				190 ²⁾		
E84AVBxE1524						
E84AVBxE1522	1.5 ... 3.0	70	244	162	230	1.9
E84AVBxE222x				190 ²⁾		
E84AVBxE3024						

2) Dimensions valid for devices with hardware version 1x.

6 Electrical installation

6.1 Important notes



Danger!

Hazardous electrical voltage

Depending on the device, all power connections remain live up to 3 minutes after the mains has been switched off.

Possible consequences:

- ▶ Death or severe injuries when touching the power terminals.

Protective measures:

- ▶ Wait for at least 3 minutes before working on the power terminals.
- ▶ Make sure that all power terminals are deenergised.



Danger!

Dangerous voltage

The leakage current to earth (PE) is > 3.5 mA AC or > 10 mA DC.

Possible consequences:

- ▶ Death or severe injuries when the device is touched in the event of a fault.

Protective measures:

- ▶ Implement the actions required in the EN 61800-5-1. Especially:
 - Fixed installation of the machine
 - PE connection for the controller and the machine must conform to standards (PE conductor diameter ≥ 10 mm² or PE conductor must be connected twice)



Stop!

No device protection in the event of too high mains voltages

The mains input is not fused internally.

Possible consequences:

- ▶ Destruction of the device if the mains voltage is too high.

Protective measures:

- ▶ Observe the max. permissible mains voltage.
- ▶ Fuse the device correctly on the supply side against mains fluctuations and voltage peaks.

**Stop!****Overvoltage at devices with 230-V mains connection**

An impermissible overvoltage may occur if the central supply of the N conductor is interrupted if the devices are connected to a TN three-phase system.

Possible consequences:

- ▶ Destruction of the device

Protective measures:

- ▶ Provide for the use of isolating transformers.

**Stop!**

The drive controller contains electrostatically sensitive components.

The personnel must be free of electrostatic charge when carrying out assembly and service operations.

**Stop!****Terminal strips and pluggable terminal strip X109**

During operation high voltages and arcing can be caused when:

- ▶ wiring of the terminal strips (inserting or removing wires).
- ▶ plugging or removing the terminal strip X109.

Possible consequences:

- ▶ Damage of the devices

Protective measures:

- ▶ Switch off device.
- ▶ Only wire the terminal strip (insert or remove wires) in deenergised status.
- ▶ Only plug or remove the terminal strip X109 in deenergised status.

**Note!**

Switching on the controller motor side is permissible for safety shutdown (emergency stop) and for operation of several motor on the controller (only in V/f operating mode!).

Please observe the following:

- ▶ When switching with the controller enabled, you can activate monitoring functions of the controller. If no monitoring function is activated, switching is permissible.
- ▶ The switching elements on the motor side must be dimensioned in accordance with the maximum occurring load.

6.1.1 Electrical isolation

The protective insulation of the "8400 Inverter Drives" controllers is implemented according to EN 61800-5-1. The following illustration shows the insulation concept.

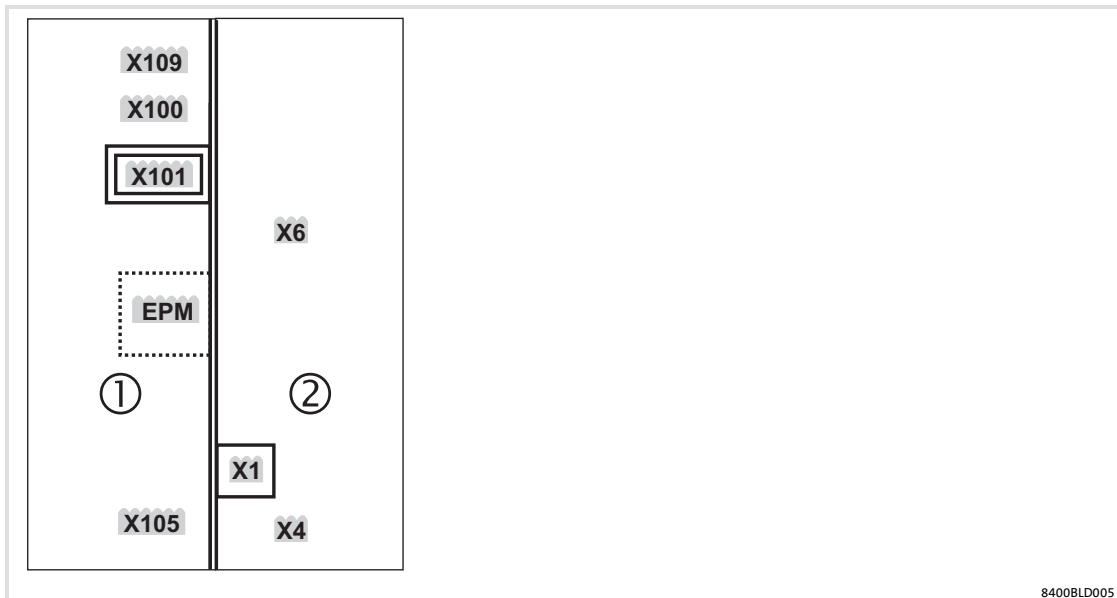

Fig. 6-1 Electrical isolation between power terminals, control terminals and housing

Legend			
	⋮		Isolation through functional insulation
			Isolation through basic insulation
			Safe isolation by double or reinforced insulation Protection against accidental contact is guaranteed without any further measures.
Range	Connection	Name	Explanation
Power ①	X100	Mains	Safe isolation towards X101 and all control terminals
	X109	DC bus	
	X105	Motor	
	X101	Relay contact	Safe isolation towards X100, X105, X109 and all control terminals
	EPM	Memory module	Safe isolation towards other control terminals; functional insulation towards power terminals
Control ②	X1	System bus (CANopen)	Basic insulation towards other control terminals; safe isolation towards power terminals
	X4	Analog IO	
		Digital Inputs	Safe isolation towards power terminals
	X4	Digital output	
	X6	Diagnostics	Safe isolation towards power terminals

6 Electrical installation

Important notes
Device protection

6.1.2 Device protection

- ▶ In case of condensation, do not connect the controller to the mains voltage before the moisture has evaporated completely.
- ▶ The controller must be protected by external fuses.

6.1.3 Maximum motor cable length

- ▶ The motor cable must be as short as possible for having a positive effect on the drive behaviour.
- ▶ For group drives (several motors connected to one drive controller) the resulting cable length l_{res} is the crucial factor:

$$l_{res} [m] = (l_1 + l_2 + l_3 \dots + l_i) \cdot \sqrt{i}$$

l_x	Length of the individual motor cable
l_{res}	Resulting length of the motor cable
i	Number of the individual motor cables

- ▶ At rated mains voltage and a switching frequency of 4 kHz and without additional output filters, the maximum permissible length of the motor cable is as follows:
 - 50 m shielded
 - 100 m unshielded



Note!

For compliance with EMC regulations, the permissible cable lengths must be reduced.

6.1.4 Motor protection

- ▶ Extensive protection against overload:
 - Through overcurrent relay or temperature monitoring.
 - We recommend to use thermostats for motor temperature monitoring.
 - Thermostat contacts can be used to activate a digital input DI1 ... DI4 for "external fault" alarm.
- ▶ Only use motors which have a suitable insulation for the inverter operation:
 - Insulation resistance: min. $\hat{u} = 1.5 \text{ kV}$, min. $du/dt = 5 \text{ kV}/\mu\text{s}$
 - When using motors with an unknown insulation resistance, please contact your motor supplier.

6.1.5 Interaction with compensation equipment

- ▶ Controllers only consume very little reactive power of the fundamental wave from the AC supply mains. Therefore a compensation is not required.
- ▶ If the controllers are connected to a supply system with compensation equipment, this equipment must be used with chokes.
 - For this, contact the supplier of the compensation equipment.

6.1.6 Safety notes for the installation according to U_L or U_R



Warnings!

- ▶ The device has no overspeed protection.
- ▶ The integral solid state protection does not provide branch circuit protection and that branch circuit protection has to be provided externally in accordance with manufacturers instructions, the National Electrical Code and any additional codes.
- ▶ Suitable for use on a circuit capable of delivering not more than 200,000 rms symmetrical amperes, at the maximum voltage rating marked on the device.
- ▶ Motor overload is provided at 125% of rated current. The overload trip point must be enabled and adjusted by parameterization.
- ▶ Shall be installed in a pollution degree 2 macro-environment.
- ▶ Maximum surrounding air temperature: 55 °C (☞ 4.2)
- ▶ Use minimum 75 °C copper wire only, except for control circuits.

6 Electrical installation

Installation according to EMC (installation of a CE-typical drive system)
Shielding

6.2 Installation according to EMC (installation of a CE-typical drive system)

Design of the cables

- ▶ It is imperative to comply with the regulations concerning minimum cross-sections of PE conductors. The cross-section of the PE conductor must be at least as large as the cross-section of the power connections.
- ▶ The cables used must comply with the approvals required for the location (e.g. UL).

6.2.1 Shielding

Requirements

- ▶ The effectiveness of a shielded cable is reached by:
 - Providing a good shield connection through large-surface shield contact.
 - Using only braided shields with low shield resistance made of tin-plated or nickel-plated copper braid.
 - Using braided shields with an overlap rate $> 70\%$ and an overlap angle of 90° .
 - Keeping unshielded cable ends as short as possible.

Use system cables or shielded cables for these connections:

- ▶ Motor
- ▶ Motor holding brake (shielding is required when being integrated into the motor cable; connection to optional motor brake control)
- ▶ Motor temperature monitoring
- ▶ Analog signals (inputs and outputs; single-sided shield connection to the controller)

The following connections need not be shielded:

- ▶ 12-V supply
- ▶ Digital signals up to a cable length of 3 m

Connection system

- ▶ Connect the shield with a large surface and fix it with a conductive clamp.
- ▶ Connect the shield directly to the terminal X13.
 - If required, additionally connect the shield to the conductive and earthed mounting plate in the control cabinet.
 - If required, additionally connect the shield to the cable clamp rail.

Realisation

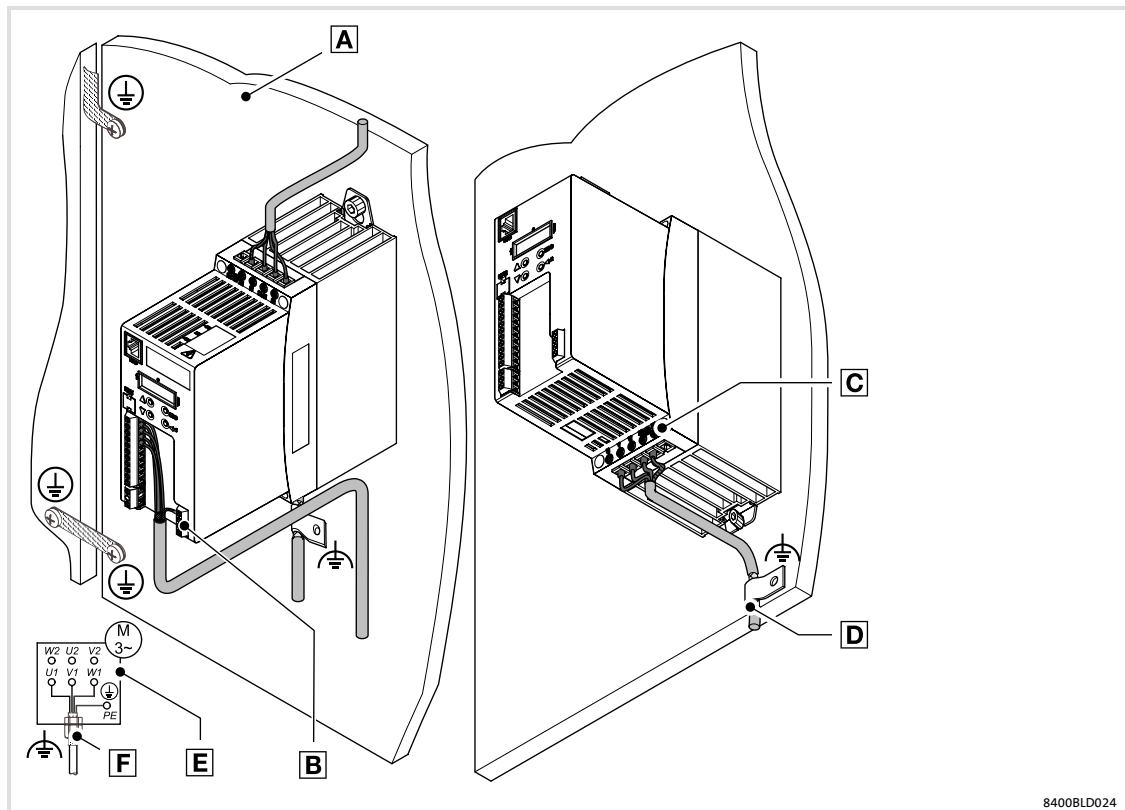

Fig. 6-2 Wiring in compliance with EMC standards

- A** Mounting plate with electrically conductive surface
- B** Control cables connected to the X13 terminal (I/O Shields)
- C** Terminal for motor PE
- D** Motor cable connected to the mounting plate (functional earth)
- E** Star or delta connection as indicated on the motor nameplate
- F** EMC cable gland (not included in the scope of supply)

8400BLD024

6

Electrical installation

Installation according to EMC (installation of a CE-typical drive system)

Mains connection, DC supply

6.2.2

Mains connection, DC supply

- ▶ Drive controllers or mains chokes may be connected to the mains via unshielded single cores or cables.
- ▶ For DC-bus operation or DC supply, use shielded cables.
- ▶ The cable cross-section must be dimensioned for the corresponding fusing (national and regional regulations must be observed).

6.2.3 Motor cables

- ▶ Only use shielded motor cables with braids made of tinned or nickel-plated copper. Shields made of steel braids are not suitable.
 - The overlap rate of the braid must be at least 70 % with an overlap angle of 90 °.
- ▶ The cables used must correspond to the requirements at the location (e.g. EN 60204-1).
- ▶ Shield the cable for motor temperature monitoring (thermal contact) and install it separately from the motor cable.
 - In Lenze system cables, the cable for brake control is integrated into the motor cable. If this cable is not required for brake control, it can also be used to connect the motor temperature monitoring up to a length of 50 m.
- ▶ Connect the shield with a large surface and fix it with a conductive clamp.
- ▶ Connect the shield directly to the terminal X13.
 - If required, additionally connect the shield to the conductive and earthed mounting plate in the control cabinet.
- ▶ The motor cable is optimally installed if
 - it is separated from mains cables and control cables,
 - it only crosses mains cables and control cables at right angles,
 - it is not interrupted.
- ▶ If the motor cable must be opened all the same (e.g. due to chokes, contactors, or terminals):
 - The unshielded cable ends may not be longer than 100 mm (depending on the cable cross-section).
 - Install chokes, contactors, terminals etc. spatially separated from other components (with a min. distance of 100 mm).
 - Install the shield of the motor cable directly before and behind the point of separation to the mounting plate with a large surface.
- ▶ Connect the shield with a large surface to PE in the terminal box of the motor at the motor housing.
 - Metal EMC cable glands at the motor terminal box ensure a large surface connection of the shield with the motor housing.

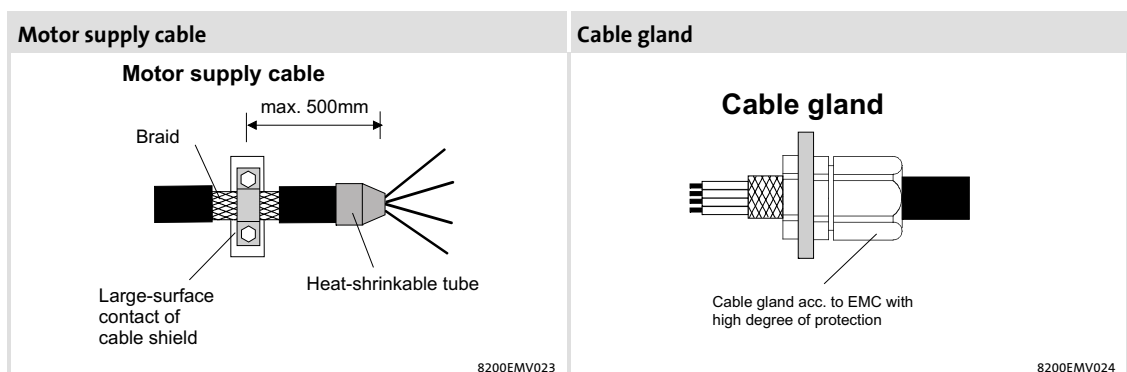

Fig. 6-3 Shielding of the motor cable

6

Electrical installation

Installation according to EMC (installation of a CE-typical drive system)

Control cables

6.2.4

Control cables

- ▶ Control cables must be shielded to minimise interference injections.
- ▶ For lengths of 200 mm and more, use only shielded cables for the analog input. Under 200 mm, unshielded but twisted cables may be used.
- ▶ For lengths of 3 m and more, use only shielded cables for digital inputs and relay output. Under 3 m, unshielded but twisted cables may be used.
- ▶ Connect the shield correctly:
 - The shield connections of the control cables must be at a distance of at least 50 mm from the shield connections of the motor cables and DC cables.
 - Connect the shield of digital input and output cables at both ends.
 - Connect the shield of analog input and output cables at one end (at the drive controller).
- ▶ To achieve an optimum shielding effect (in case of very long cables, with high interference) one shield end of analog input and output cables can be connected to PE potential via a capacitor (e.g. 10 nF/250 V) (see sketch).

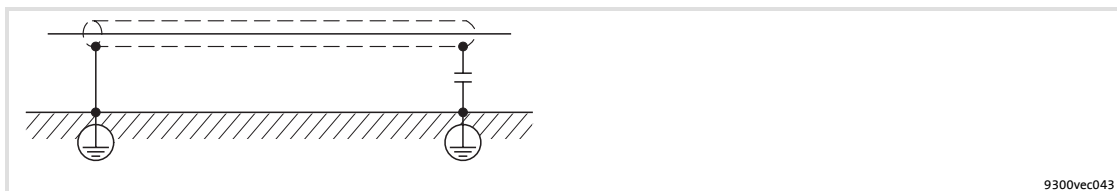

Fig. 6-4 Shielding of long, analog control cables

9300vec043

6.2.5 Installation in the control cabinet

Mounting plate requirements

- ▶ Only use mounting plates with conductive surfaces (zinc-coated or V2A-steel).
- ▶ Painted mounting plates are not suitable even if the paint is removed from the contact surfaces.
- ▶ If several mounting plates are used, ensure a large-surface connection between the mounting plates (e.g. by using earthing strips).

Mounting of the components

- ▶ Connect the controller and RFI filter to the grounded mounting plate with a surface as large as possible.
- ▶ No DIN rail mounting!

Optimum cable routing

- ▶ The motor cable is perfectly installed if
 - it is routed separately of mains cables and control cables,
 - it crosses mains cables and control cables only at a right angle,
- ▶ Cables must be routed close to the mounting plate (reference potential) as freely suspended cables act like antennas.
- ▶ Cables must be routed in a straight line to the terminals (avoid “tangle of cables”).
- ▶ Use separate cable ducts for power cables and control cables. Do not mix up different cable types in one cable duct.
- ▶ Minimise coupling capacitances and inductances caused by unnecessary cable lengths and reserve loops.
- ▶ Short-circuit unused cores to the reference potential.
- ▶ Route the positive and negative cables for DC 24 V close to each other over the total length to prevent loops.

Earth connections

- ▶ Connect all components (drive controllers, chokes, filters) to a central earthing point (PE rail).
- ▶ Set up a star-shape earthing system.
- ▶ Comply with the corresponding minimum cable cross-sections.

Electrical installation

Installation according to EMC (installation of a CE-typical drive system)
Installation in the control cabinet

Continuation of cable routing

Separation of the "hot" motor cable from the control, signal, and mains cables:

- ▶ Never install motor and signal cables in parallel and only cross at right angles
- ▶ The cables of a 24 V power supply unit (plus and minus cable) must be installed closely together over their entire length in order that no loops may occur.

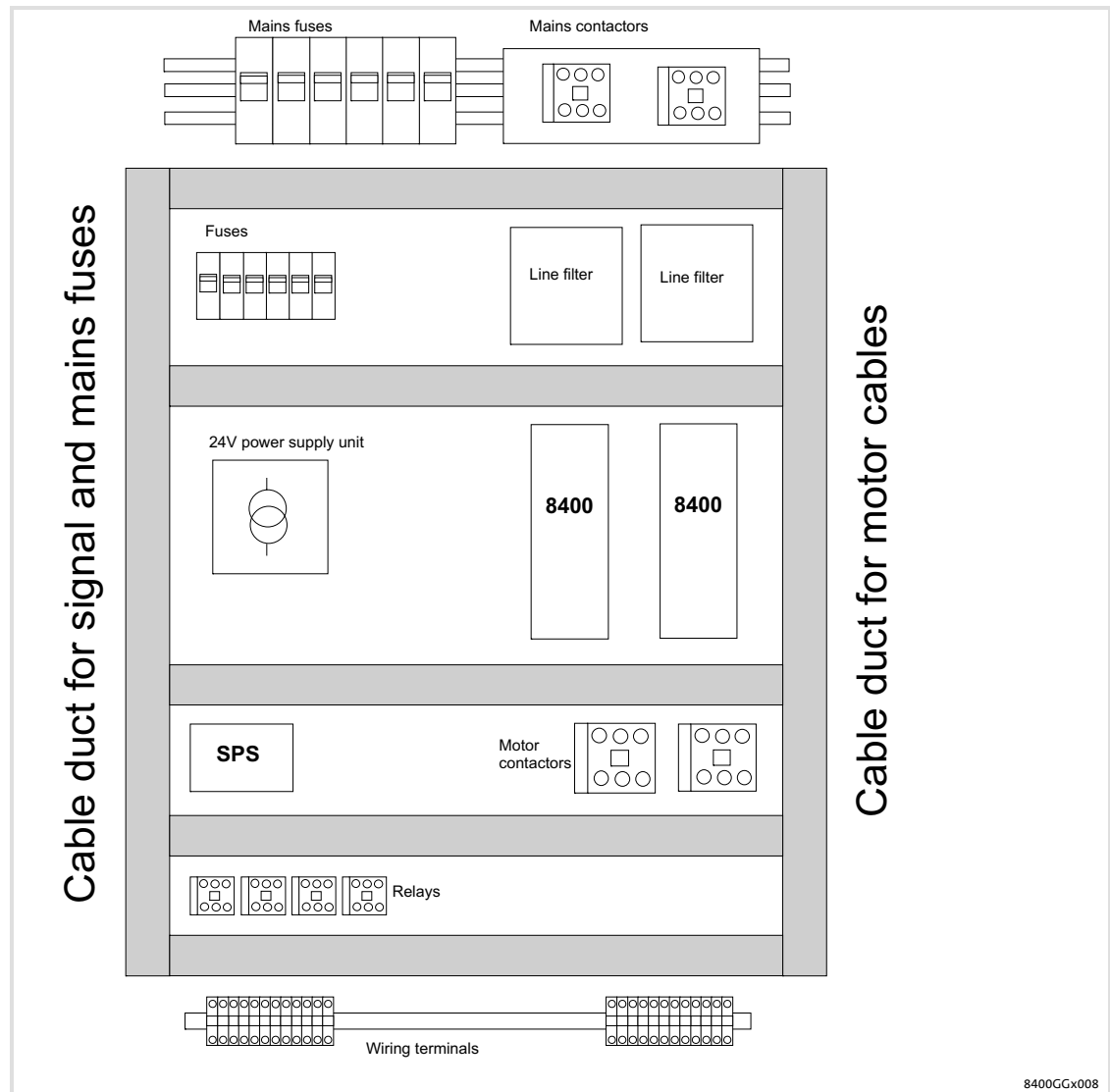

Fig. 6-5 Cable routing in the control cabinet

6.2.6 Wiring outside the control cabinet

Notes for cable routing outside the control cabinet:

- ▶ The longer the cables the greater the space between the cables must be.
- ▶ If cables for different signal types are routed in parallel, the interferences can be minimized by means of a metal barrier or separated cable ducts.

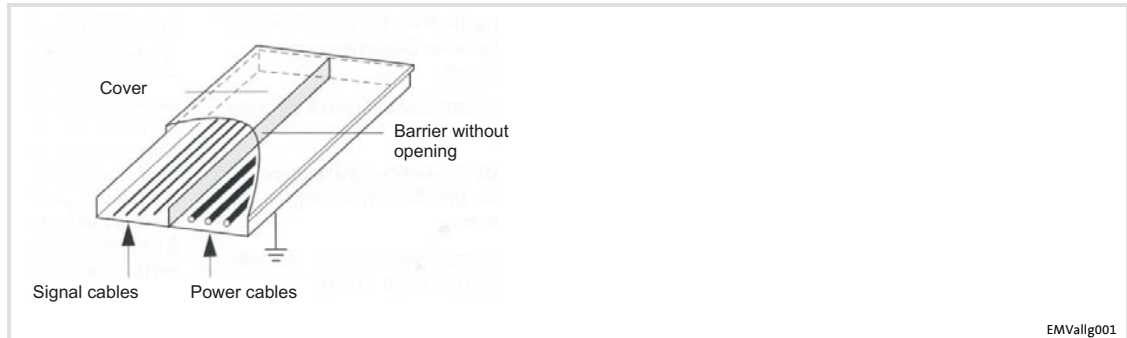

Fig. 6-6 Cable routing in the cable duct with barrier

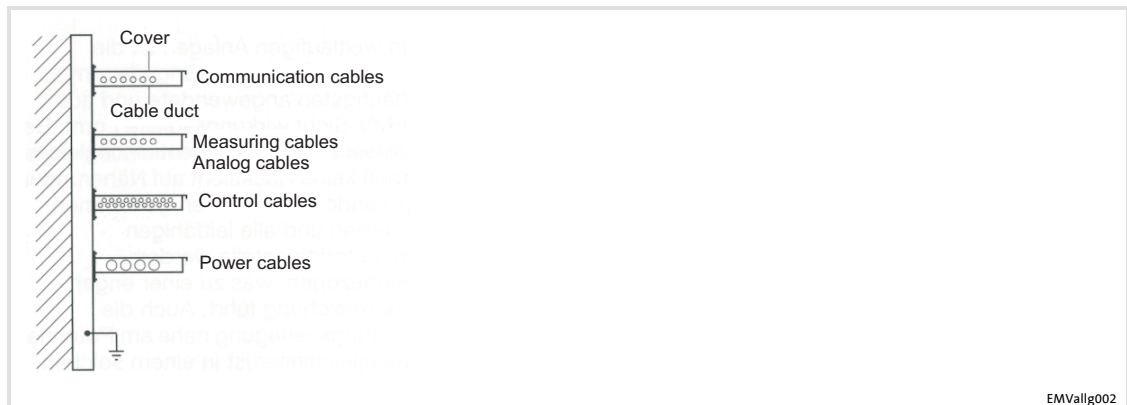

Fig. 6-7 Cable routing in separated cable ducts

6

Electrical installation

Installation according to EMC (installation of a CE-typical drive system)

Wiring outside the control cabinet

Wiring on the mains side

- ▶ It is possible to connect the controller and the mains choke to the mains via single cores or unshielded cables.
- ▶ The cable cross-section must be rated for the assigned fuse protection (VDE 0160).

Wiring on the motor side**Stop!**

The motor cable is highly susceptible to interference. Therefore you will achieve an optimum wiring on the motor side if you

- ▶ exclusively use shielded and low-capacitance motor cables.
- ▶ do **not** integrate any further cable into the motor cable (e.g. for blowers etc.).
- ▶ shield the supply cable for temperature monitoring of the motor (PTC or thermostat) and install it separately from the motor cable.

Special conditions allow you to integrate the supply cable for temperature monitoring of the motor into the motor cable: (📖 53)

Installation according to EMC (installation of a CE-typical drive system)
Detecting and eliminating EMC interferences

6.2.7 Detecting and eliminating EMC interferences

Fault	Cause	Remedy
Interferences to analog setpoints of devices and measuring systems	Unshielded motor cable	Use shielded motor cable
	Contact surface of shield is too small	Provide optimum shielding according to instructions
	Shield of the motor cable is interrupted by terminal strips, switches etc.	<ul style="list-style-type: none"> Keep components separated from all other parts by at least 100mm Use motor choke
	Additional, unshielded cables are installed within the motor cable (e.g. for motor temperature monitoring)	Separate the additional cables and shield them
	Unshielded motor cable ends too long	Shorten unshielded cable ends to maximally 40 mm
Conducted interference level is exceeded on the supply side	Terminal strips for the motor cable are directly installed next to the supply terminals	Keep the terminal strips for the motor cable separated from the supply and other control terminals by at least 100 mm
	Painted mounting plate	Optimise PE connection: <ul style="list-style-type: none"> Remove paint Use zinc-coated mounting plate
	HF short circuit	Check cable routing

6 Electrical installation

Devices in the power range 0.25 ... 2.2 kW (1/N/PE AC 230 V)

Example circuits

6.3 Devices in the power range 0.25 ... 2.2 kW (1/N/PE AC 230 V)

6.3.1 Example circuits

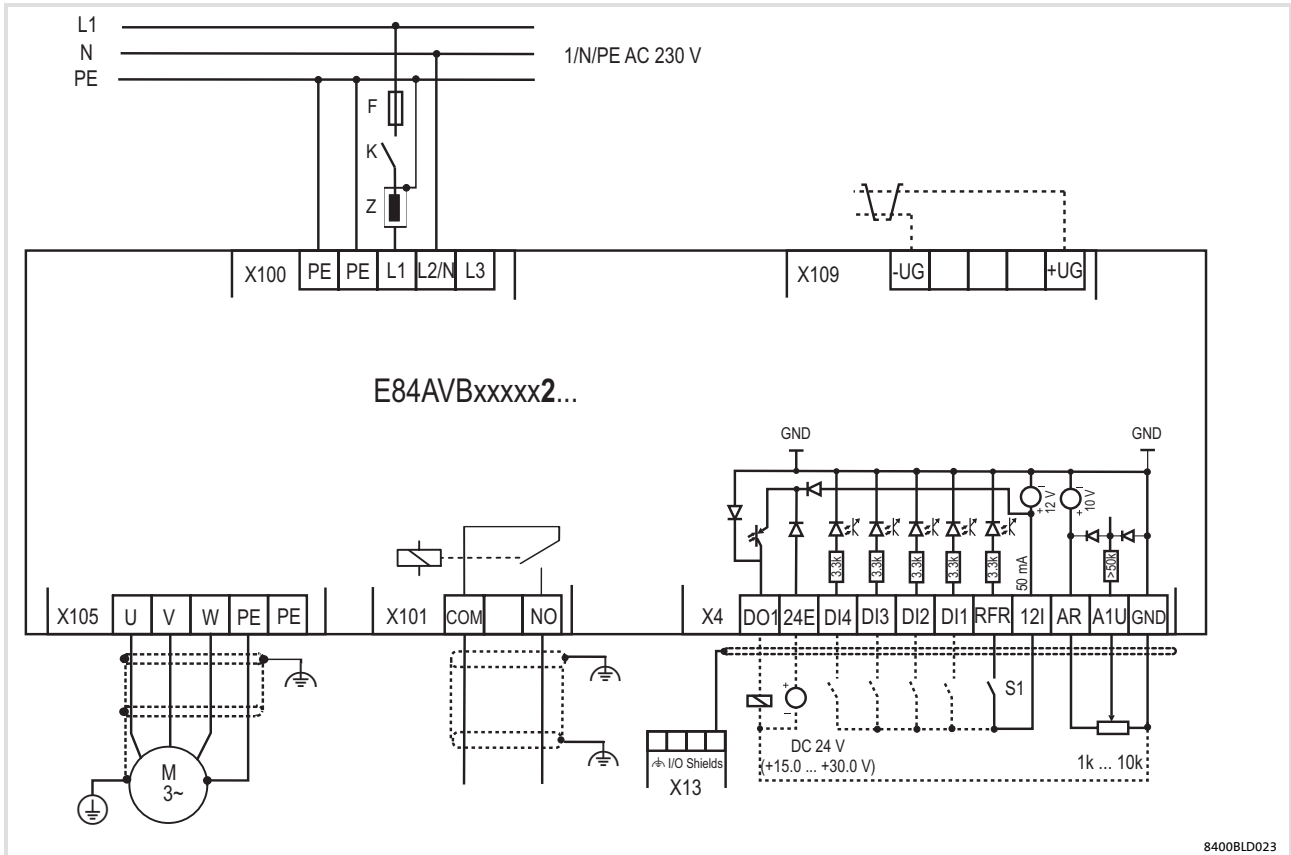

Fig. 6-8 Wiring for controllers with 230-V mains connection

DO1

The digital output is not available for devices with nameplate data E84AVBDxxxxSX0

84008LD023

6.3.2 Terminal assignment of the power connections

Strip cables

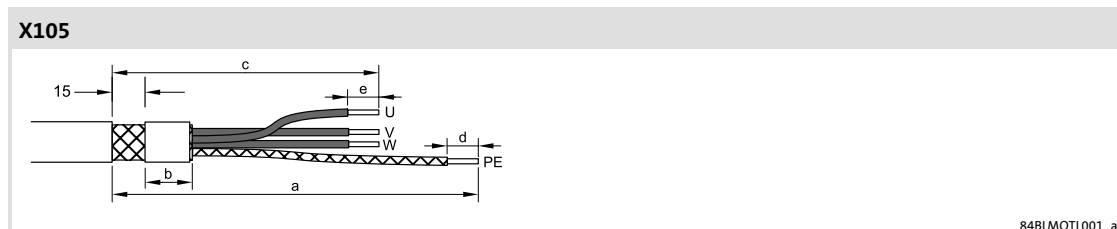

	U, V, W			PE	
	b	c	e	a	d
	[mm]			[mm]	
E84AVBxE2512	75	130	7	160	7
E84AVBxE3712					
E84AVBxE5512	95	150	7	180	7
E84AVBxE7512					
E84AVBxE1122					
E84AVBxE1522					
E84AVBxE2222					

How to proceed:

1. Strip motor cable as specified.
2. Fold back shield of motor cable over the cable sheath. Keep unshielded cable ends as short as possible.
3. Fix shield on the cable sheath (e.g. using a heat-shrinkable tube).
4. Fasten wire end ferrule to PE cable.
 - The other cables may be wired without using wire end ferrules.
5. Connect motor cable shield to PE terminal of inverter.
 - For strain relief of the cables, additional measures are required.





Electrical installation

Devices in the power range 0.25 ... 2.2 kW (1/N/PE AC 230 V)

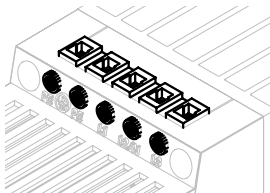
Terminal assignment of the power connections

Mains connection

Terminal X100	Labelling	Description
 84BDGG001	L1	Mains phase L
	L2/N	Mains phase L/Neutral conductor N
	PE	PE conductor on the supply side

Terminal data					
	Max. conductor cross-section		Tightening torque		
	[mm ²]	[AWG]	[Nm]	[lb-in]	
E84AVBxE2512 E84AVBxE3712 E84AVBxE5512 E84AVBxE7512 E84AVBxE1122	1 ... 2.5	18 ... 14	0.5	4.5	3.5 x 0.6
E84AVBxE1522 	1 ... 2.5	18 ... 12			
	1 ... 4	18 ... 10			
E84AVBxE2222 	1 ... 4	18 ... 12			
	1 ... 6	18 ... 10			

For inverter drives of type E84AVBDE2222 and E84AVBDE1522, the following should be considered:

- ▶ when the inverter is connected to the mains without a mains choke, the terminal X100 can accommodate
 - cables with cross-sections of maximum 4 mm² without wire end ferrules.
 - cables with cross-sections of maximum 4 mm² or thicker with a wire end ferrule only if pin-end connectors are used.

Connecting the controller to protective earth

Using the PE connections on the mains side, the controller can be connected to protective earth. Additional protective earthing of the controller can be carried out via the second PE connection in order to comply with the requirements regarding the operation of devices with an increased discharge current to PE.

How to proceed:

1. Observe the requirements for wiring on the mains side (📖 52).
2. Connect a second cable to the vacant PE connection and earth it.

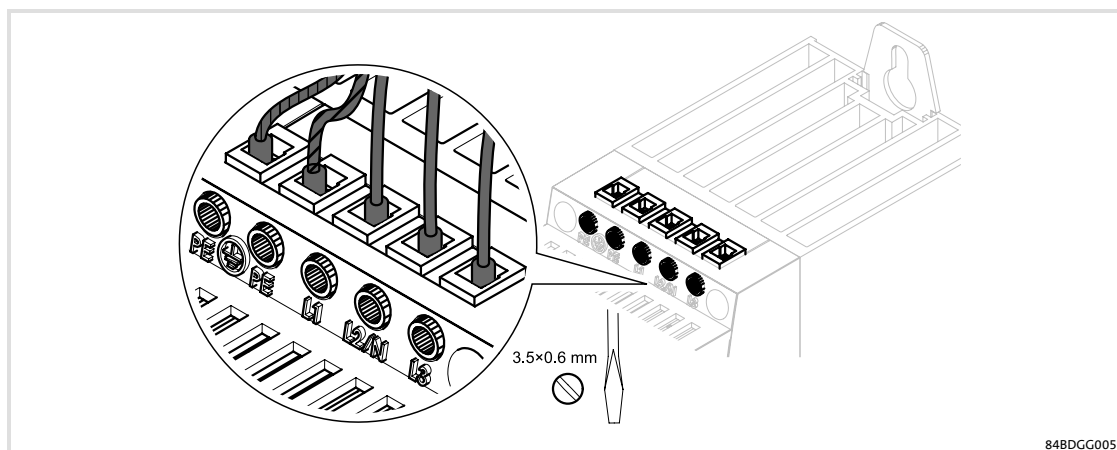

Fig. 6-9 Connecting the controller to protective earth on the mains side

6

Electrical installation

Devices in the power range 0.25 ... 2.2 kW (1/N/PE AC 230 V)
Terminal assignment of the power connections

DC bus

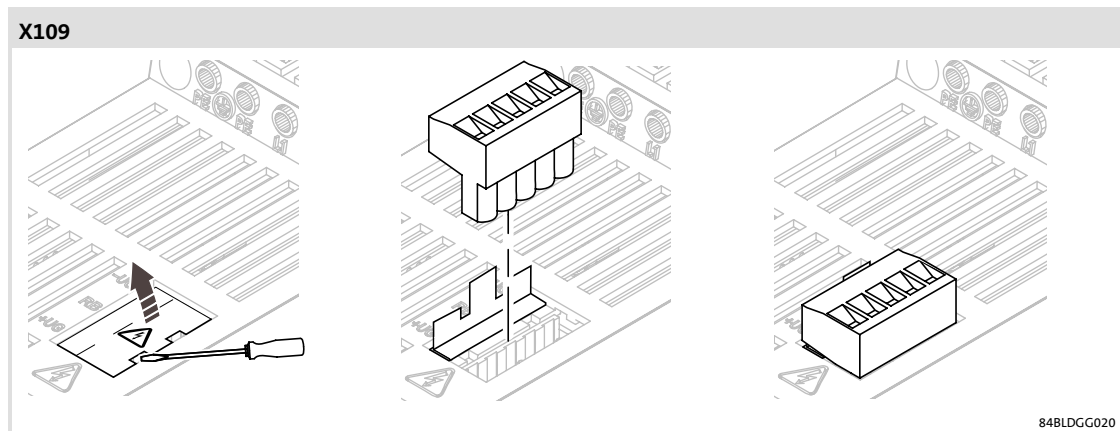
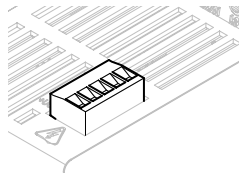



Fig. 6-10 Inserting terminal X109

Before plugging in the terminal X109:

1. Switch off the controller and wait for at least 3 minutes before start working.
2. Make sure that there is no residual voltage.
3. Pull the cover carefully to the side without removing it completely.
4. Plug in the terminal.

Terminal X109	Labelling	Description
	-UG RB ¹⁾ + UG	DC bus for connecting devices operating at 230 V to an external brake module, DC bus system or DC supply (only with devices in the power range from 0.25 to 1.5 kW)

¹⁾ not connected

Terminal data					
	Max. conductor cross-section		Tightening torque		
	[mm ²]	[AWG]	[Nm]	[lb-in]	
E84AVBxE2512	0.5 ... 1.5	22 ... 16	0.5	4.5	3.5 x 0.6
E84AVBxE3712					
E84AVBxE5512					
E84AVBxE7512					
E84AVBxE1122					
E84AVBxE1522					
E84AVBxE2222					

Devices in the power range 0.25 ... 2.2 kW (1/N/PE AC 230 V)
Terminal assignment of the power connections

Motor connection

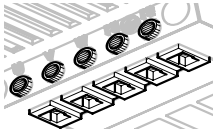
Terminal X105	Labelling	Description
 84BDGG012	U, V, W	Motor
	PE	PE conductor

Terminal data					
	Max. conductor cross-section		Tightening torque		
	[mm ²]	[AWG]	[Nm]	[lb-in]	
E84AVBxE2512	1 ... 2.5	18 ... 12	0.5	4.5	3.5 x 0.6
E84AVBxE3712					
E84AVBxE5512					
E84AVBxE7512					
E84AVBxE1122					
E84AVBxE1522					
E84AVBxE2222					

6 Electrical installation

Devices in the power range from 0.37 to 3 kW (3/PE AC 400 V)
Example circuits

6.4 Devices in the power range from 0.37 to 3 kW (3/PE AC 400 V)

6.4.1 Example circuits

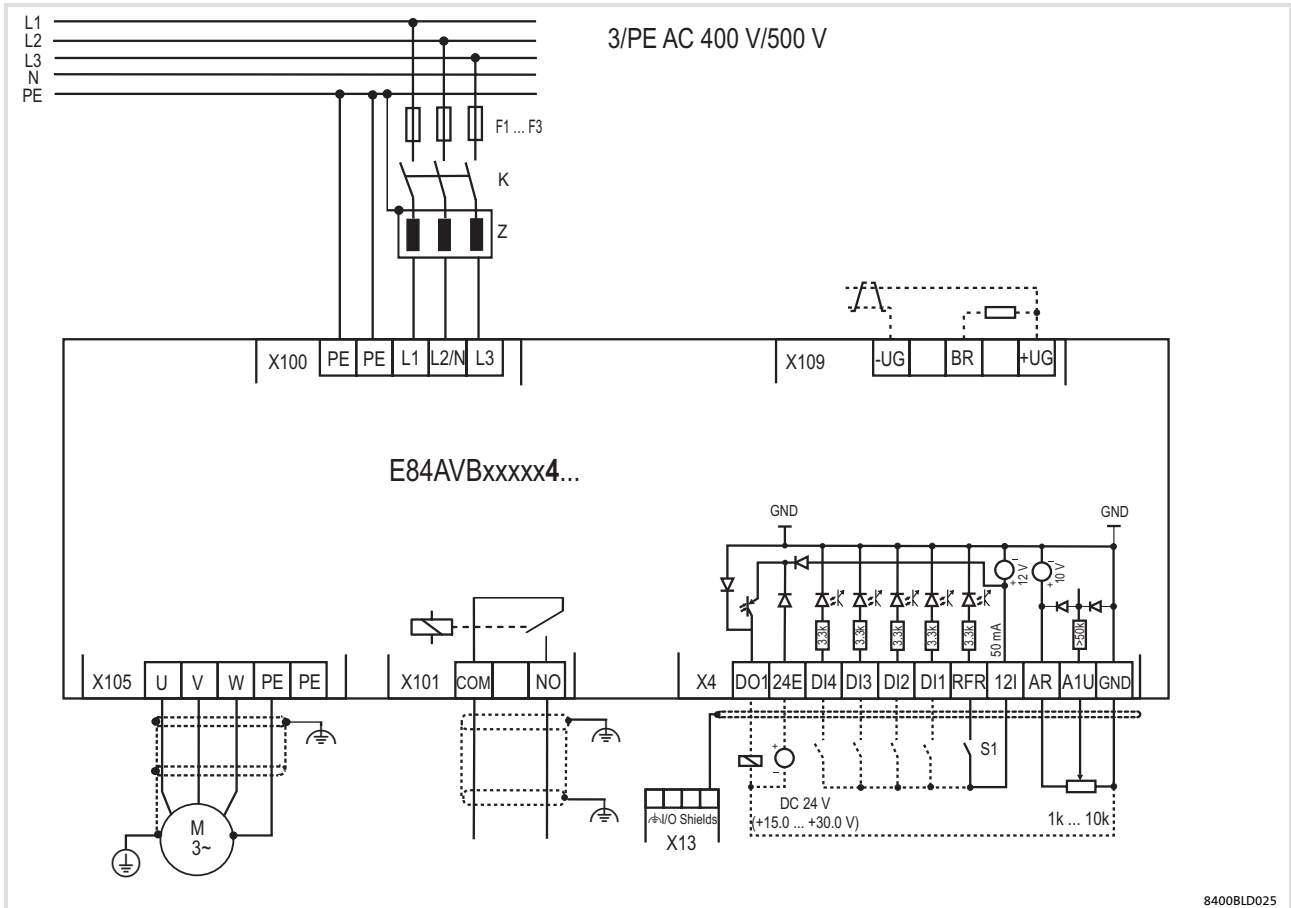

Fig. 6-11 Wiring for controllers with 400-V/500-V mains connection

DO1

The digital output is not available for devices with nameplate data E84AVBDxxxxSX0

84008LD025

6.4.2 Terminal assignment of the power connections

Strip cables

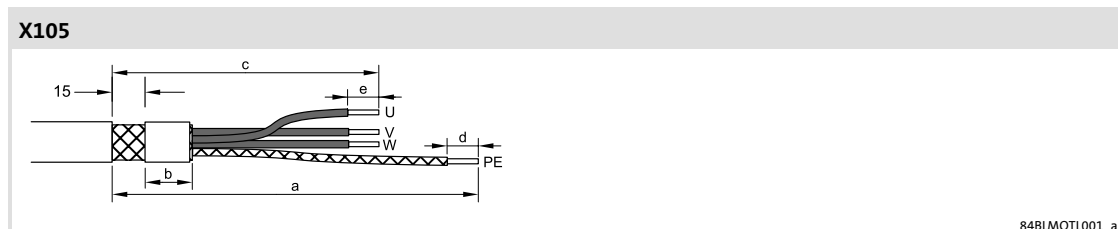

	U, V, W			PE	
	b	c	e	a	d
	[mm]			[mm]	
E84AVBxE3714	95	150	7	180	7
E84AVBxE5514					
E84AVBxE7514					
E84AVBxE1124					
E84AVBxE1524					
E84AVBxE2224					
E84AVBxE3024					

How to proceed:

1. Strip motor cable as specified.
2. Fold back shield of motor cable over the cable sheath. Keep unshielded cable ends as short as possible.
3. Fix shield on the cable sheath (e.g. using a heat-shrinkable tube).
4. Fasten wire end ferrule to PE cable.
 - The other cables may be wired without using wire end ferrules.
5. Connect motor cable shield to PE terminal of inverter.
 - For strain relief of the cables, additional measures are required.

Electrical installation

Devices in the power range from 0.37 to 3 kW (3/PE AC 400 V)

Terminal assignment of the power connections

Mains connection

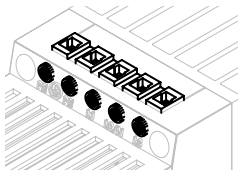
Terminal X100	Labelling	Description
 84BDGG001	L1 L2/N L3	Connection of the mains phases L1, L2/N, L3
	PE	Connection for the PE conductor

Terminal data					
	Max. conductor cross-section		Tightening torque		
	[mm ²]	[AWG]	[Nm]	[lb-in]	
E84AVBxE3714	1 ... 2.5	18 ... 12	0.5	4.5	3.5 x 0.6
E84AVBxE5514					
E84AVBxE7514					
E84AVBxE1124					
E84AVBxE1524					
E84AVBxE2224					
E84AVBxE3024					

Connecting the controller to protective earth

Using the PE connections on the mains side, the controller can be connected to protective earth. Additional protective earthing of the controller can be carried out via the second PE connection in order to comply with the requirements regarding the operation of devices with an increased discharge current to PE.

How to proceed:

1. Observe the requirements for wiring on the mains side (📖 52).
2. Connect a second cable to the vacant PE connection and earth it.

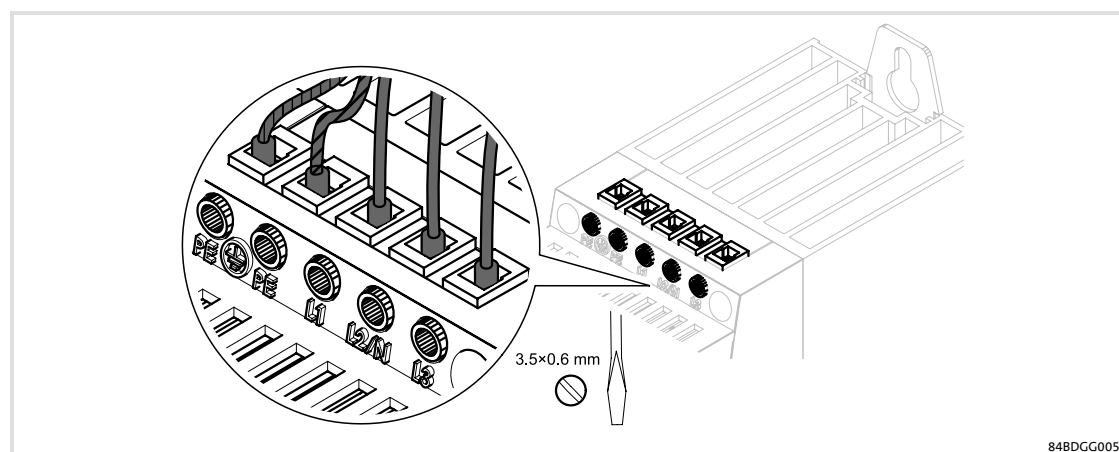

Fig. 6-12 Connecting the controller to protective earth on the mains side

Connection to the DC bus (+U_G, -U_G)

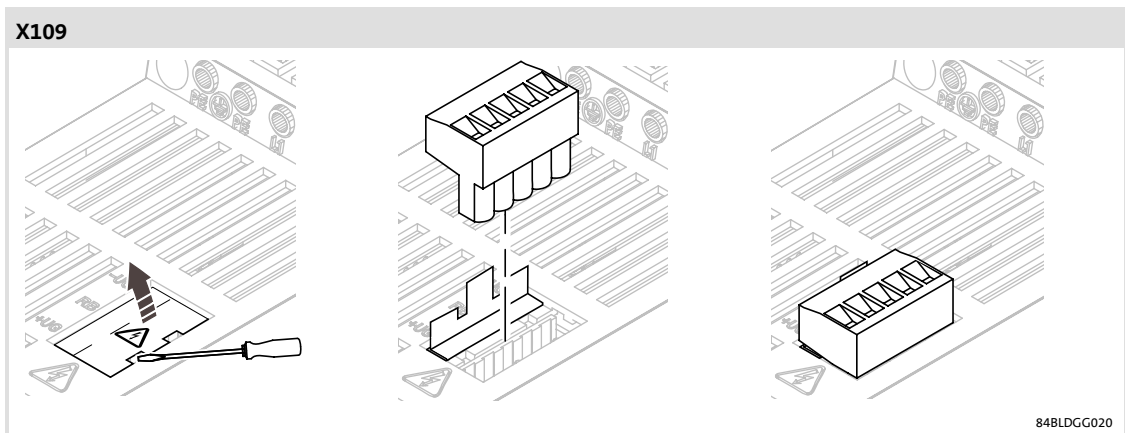
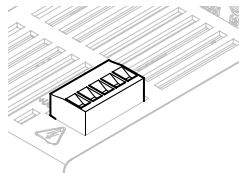



Fig. 6-13 Inserting terminal X109

Before plugging in the terminal X109:

1. Switch off the controller and wait for at least 3 minutes before start working.
2. Make sure that there is no residual voltage.
3. Pull the cover carefully to the side without removing it completely.
4. Plug in the terminal.

Terminal X109	Labelling	Description
	- UG RB + UG	DC bus for connecting devices operating at 400 V to a DC bus system or DC supply.

Terminal data					
	Max. conductor cross-section		Tightening torque		
	[mm ²]	[AWG]	[Nm]	[lb-in]	
E84AVBxE3714	0.5 ... 1.5	22 ... 16	0.5	4.5	3.5 x 0.6
E84AVBxE5514					
E84AVBxE7514					
E84AVBxE1124					
E84AVBxE1524					
E84AVBxE2224					
E84AVBxE3024					

Electrical installation

Devices in the power range from 0.37 to 3 kW (3/PE AC 400 V)

Terminal assignment of the power connections

Motor connection

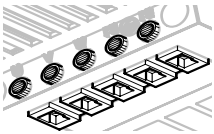
Terminal X105	Labelling	Description
	U, V, W	Motor
	PE	PE conductor

84BDGG012

Terminal data					
	Max. conductor cross-section		Tightening torque		
	[mm ²]	[AWG]	[Nm]	[lb-in]	
E84AVBxE3714	1 ... 2.5	18 ... 12	0.5	4.5	3.5 x 0.6
E84AVBxE5514					
E84AVBxE7514					
E84AVBxE1124					
E84AVBxE1524					
E84AVBxE2224					
E84AVBxE3024					

Connection of external brake resistor

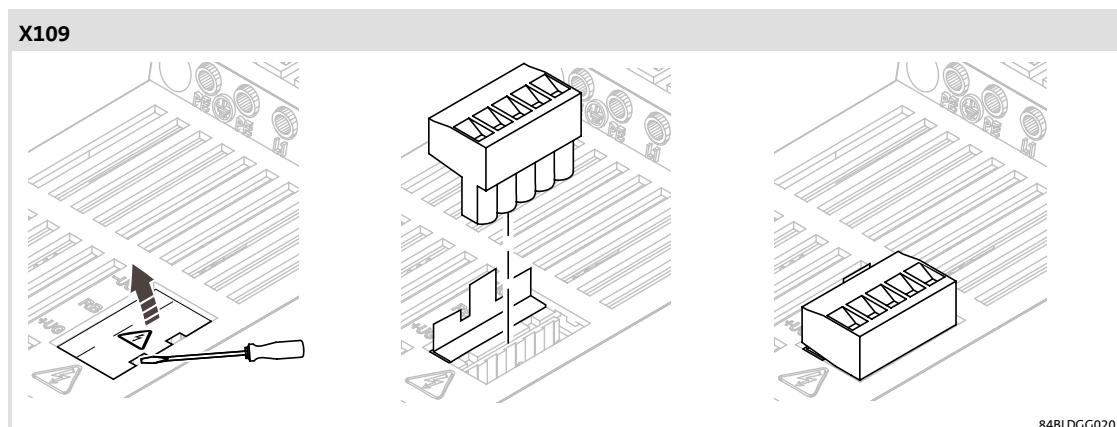
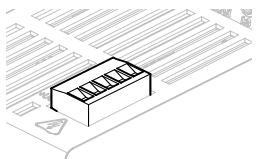

Fig. 6-14 Inserting terminal X109

Before plugging in the terminal X109:

1. Switch off the controller and wait for at least 3 minutes before start working.
2. Make sure that there is no residual voltage.
3. Pull the cover carefully to the side without removing it completely.
4. Plug in the terminal.

Devices in the power range from 0.37 to 3 kW (3/PE AC 400 V)
Terminal assignment of the power connections

Terminal X109	Labelling	Description
 84BDGG109	-UG ¹⁾ RB + UG	DC bus for connection of external brake resistor.

1) not required when connecting an external brake resistor to the controller

Terminal data					
	Max. conductor cross-section		Tightening torque		
	[mm ²]	[AWG]	[Nm]	[lb-in]	
E84AVBxE3714	0.5 ... 1.5	22 ... 16	0.5	4.5	3.5 x 0.6
E84AVBxE5514					
E84AVBxE7514					
E84AVBxE1124					
E84AVBxE1524					
E84AVBxE2224					
E84AVBxE3024					



Please read the information on how to install and connect the brake resistor in the corresponding mounting instructions.

6 Electrical installation

Control terminals

Important notes

6.5 Control terminals

6.5.1 Important notes



Stop!

The device contains components that can be destroyed by electrostatic discharge!

Before working on the device, the personnel must ensure that they are free of electrostatic charge by using appropriate measures.

Design of the cables

- ▶ The cables used must comply with the approvals required for the location (e.g. UL).
- ▶ The effectiveness of a shielded cable is reached by:
 - Providing a good shield connection through large-surface shield contact.
 - Using only braided shields with low shield resistance made of tin-plated or nickel-plated copper braid.
 - Using braided shields with an overlap rate > 70 % and an overlap angle of 90 °.
 - Keeping unshielded cable ends as short as possible.

These terminals must be shielded:

- ▶ Analog signals (single-sided shield connection to the controller)

The following connections need not be shielded:

- ▶ Digital signals up to a cable length of 3 m

Strip cables

Strip the control cables (analog and digital) according to the dimensions given in the following table.

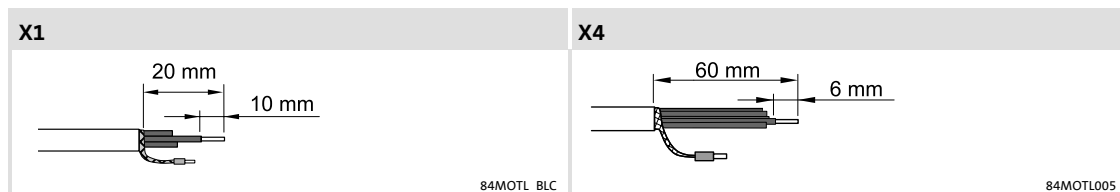

	X1		X4	
	[mm ²] [AWG]		[mm ²] [AWG]	 [Nm] [lb-in]
E84AVBxE2512	0.2 ... 1.5 24 ... 16		0.2 ... 1.5 24 ... 16	0.5 4.5
E84AVBxE371x				
E84AVBxE551x				
E84AVBxE751x				
E84AVBxE112x				
E84AVBxE152x				
E84AVBxE222x				
E84AVBxE3024				

Shield and connect cables

To shield the stripped control cables:

1. Form the cable's braided shield into a pigtail.
2. Use a wire end ferrule for more stability (optional).
3. Insert the pigtail into one of the screw terminals on X13.
4. Use a suitable screwdriver (see illustration).

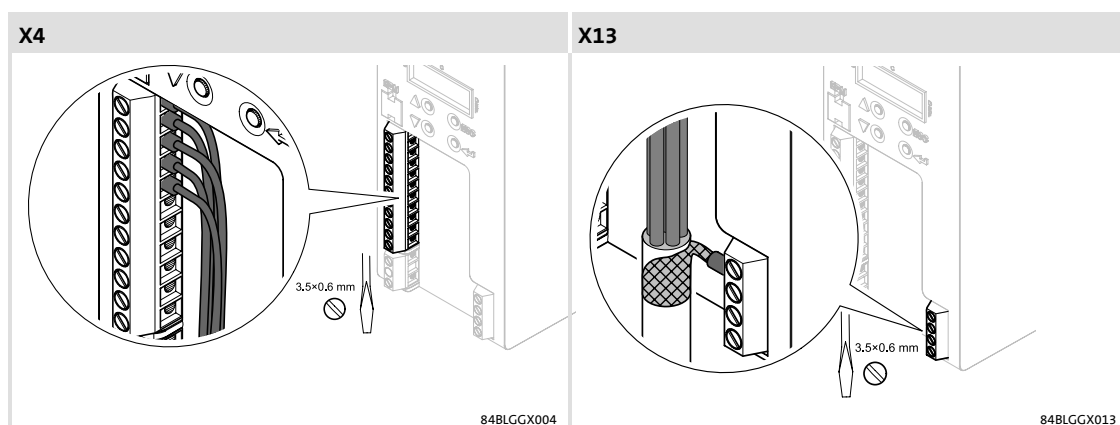

Fig. 6-15 Shielding and connecting control cables

6 Electrical installation

Control terminals

System bus connection (CANopen)

6.5.2 System bus connection (CANopen)

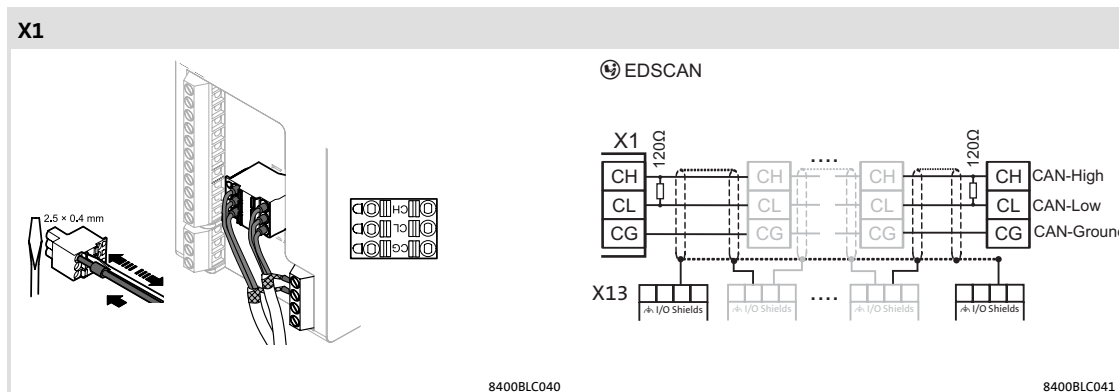



Fig. 6-16 CANopen connection

Networking several inverters

When networking several inverters to form an interconnected system, observe that the CAN bus has to be terminated between CAN-Low and CAN-High both at the first and the last physical node by a resistor, $R = 120 \Omega$.

Terminal data					
	Max. conductor cross-section		Tightening torque		
	[mm ²]	[AWG]	[Nm]	[lb-in]	
flexible	0.2 ... 1.5	24 ... 16	-	-	2.5 x 0.4
with wire end ferrule					



Note!

- Detailed information on the system bus interface and switch settings can be obtained from the "CAN communication manual", chapter "CAN on board 8400".

6.5.3 Analog input

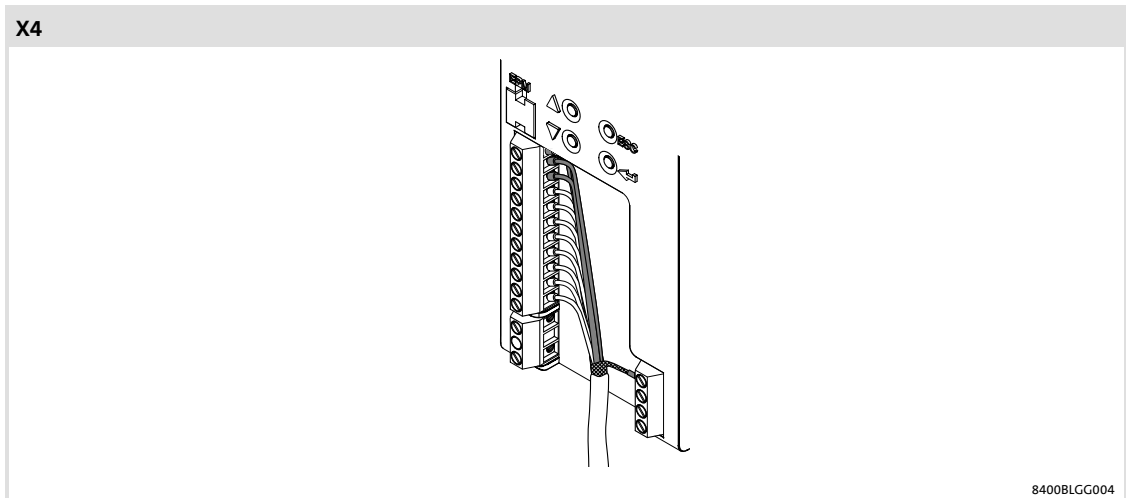

Fig. 6-17 Wiring and shielding of the analog input

Terminal X4	Labelling	Description	
	GND	GND connection for analog and digital signals	
	A1U	Analog input 1 <ul style="list-style-type: none"> For master voltage/master current configuration see C00034 	±10 V (☞ 75)
	AR	Analog Reference	reference voltage 10 V

Terminal data					
	Max. conductor cross-section		Tightening torque		
	[mm ²]	[AWG]	[Nm]	[lb-in]	
flexible	0.2 ... 1.5	24 ... 16	0.5	4.5	3.5 x 0.6
with wire end ferrule					

Electrical installation

Control terminals

Analog input

Example circuit

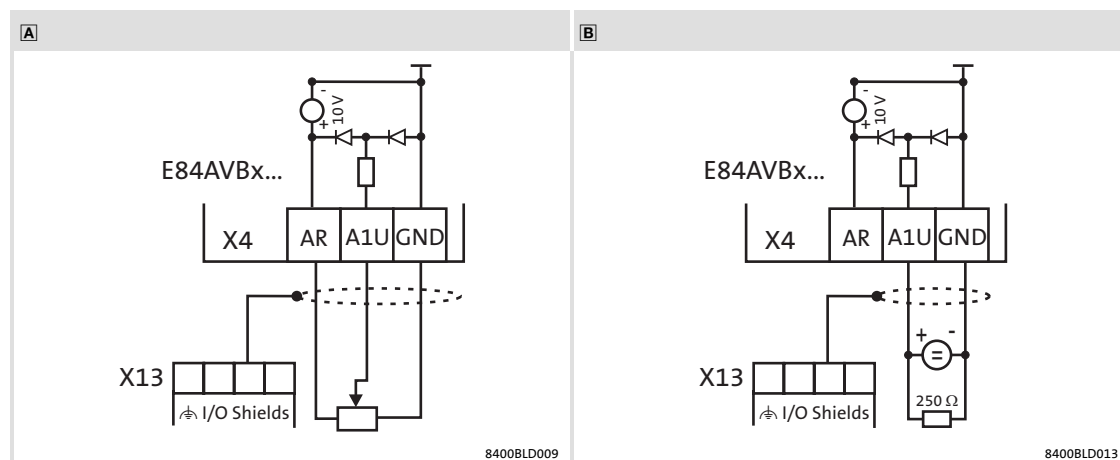

Fig. 6-18 Wiring examples of the analog input

- ▣ Potentiometer with internal controller supply
- ▣ External master current selection for a sensor signal 0 - 20 mA
- X4 Terminal for the analog input and the digital inputs and output
- X13 Terminal for I/O shields
- GND GND connection for analog and digital signals

6.5.4 External supply voltage 24 V

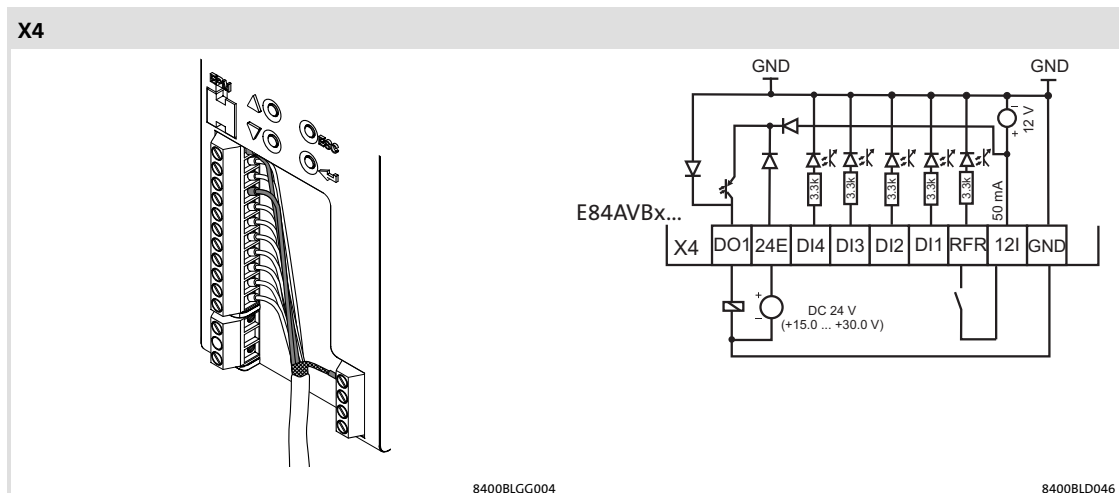

Fig. 6-19 Connection to an external supply voltage

Terminal X4	Labelling	Description
	24E	Connection for an external 24 V supply by a safely separated power supply unit (SELV/PELV), IEC 61131-2 (required for mains-independent supply of the control electronics)
	12I	Output 12 V, max. 50 mA for connecting digital inputs via potential-free contacts
	GND	Ground reference potential for the digital inputs and outputs

Terminal data					
	Max. conductor cross-section		Tightening torque		
	[mm ²]	[AWG]	[Nm]	[lb-in]	
flexible	0.2 ... 1.5	24 ... 16	0.5	4.5	3.5 x 0.6
with wire end ferrule					

6 Electrical installation

Control terminals

Digital inputs and outputs

6.5.5 Digital inputs and outputs

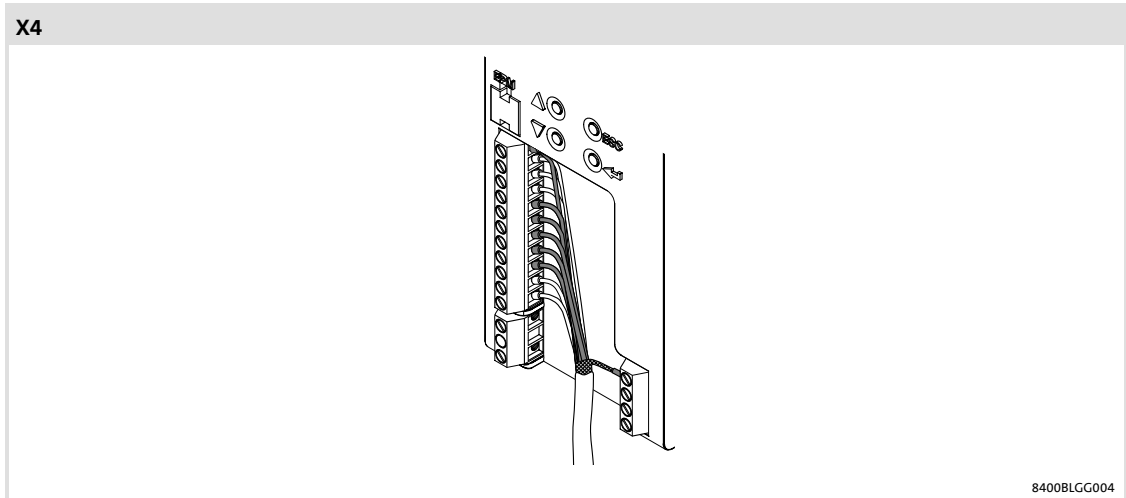

Fig. 6-20 Wiring and shielding of the digital inputs

DO1 The digital output is not available for devices with nameplate data E84AVBDxxxSX0

Terminal X4	Labelling	Description	
	RFR	Controller enable/controller inhibit, always required	
	DI1	Digital input 1	
	DI2	Digital input 2	
	DI3	Digital input 3	42
	DI4	Digital input 4	
	DO1	Digital output	
	GND	GND for analog and digital signals	

84BLGGX005

Terminal data					
	Max. conductor cross-section		Tightening torque		
	[mm ²]	[AWG]	[Nm]	[lb-in]	
flexible	0.2 ... 1.5	24 ... 16	0.5	4.5	3.5 x 0.6
with wire end ferrule					

Example circuit

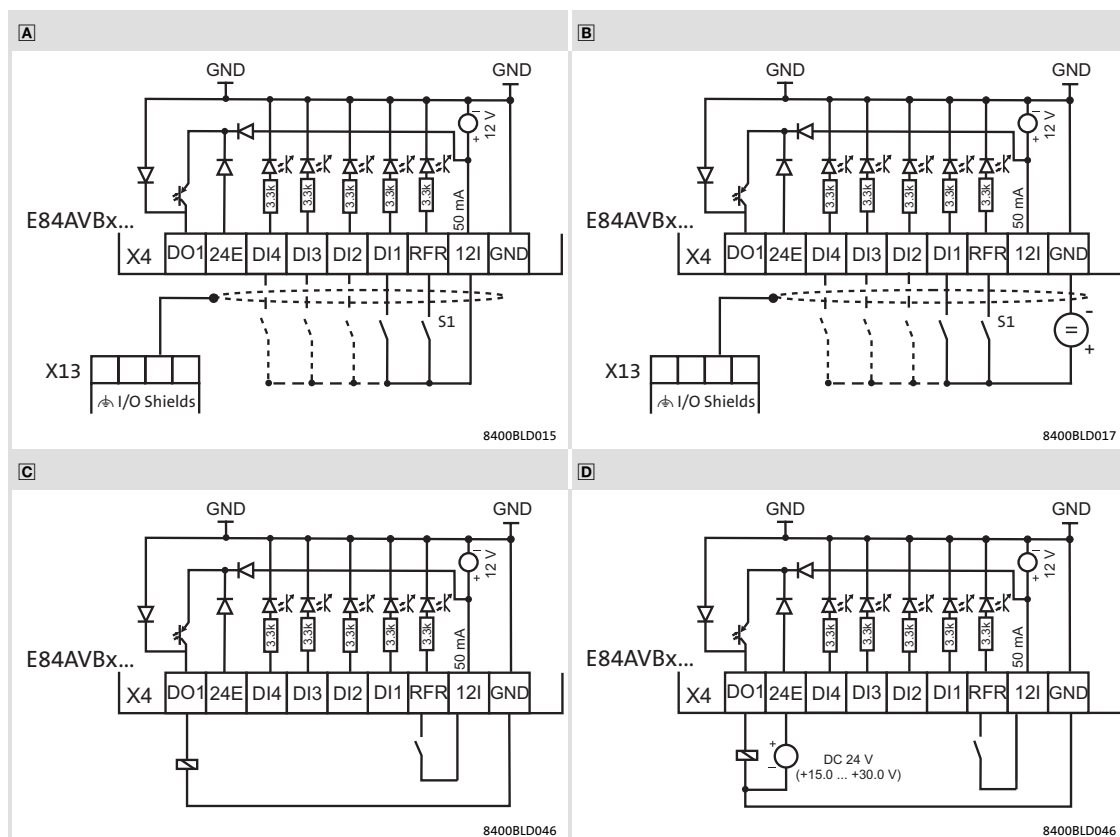

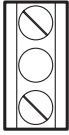

Fig. 6-21 Wiring examples of the digital inputs

- A** Wiring with one or several digital inputs (here: DI1);
option: internal 12 V supply
- B** Wiring one or several digital inputs with external 10 V to 30 V DC supply
- C** Digital output with internal 12 V supply
- D** Digital output with external 24 V supply
- RFR Input for controller enable; wiring is always required.
- X4 Terminal for the analog input and digital inputs and output
- X13 Terminal for I/O shields
- GND GND for analog and digital signals
- DO1 The digital output is not available for devices with nameplate data E84AVBDxxxxSX0

6 Electrical installation

Control terminals Relay output connection

6.5.6 Relay output connection

Terminal X101	Labelling	Description
 COM NO	COM	Central contact of relay
	NO	Relay output NO (normally open)  42

84BLGGX005

Terminal data					
	Max. conductor cross-section		Tightening torque		
	[mm ²]	[AWG]	[Nm]	[lb-in]	
flexible	0.5 ... 1.5	22 ... 16	0.5	4.5	3.5 x 0.6
with wire end ferrule					

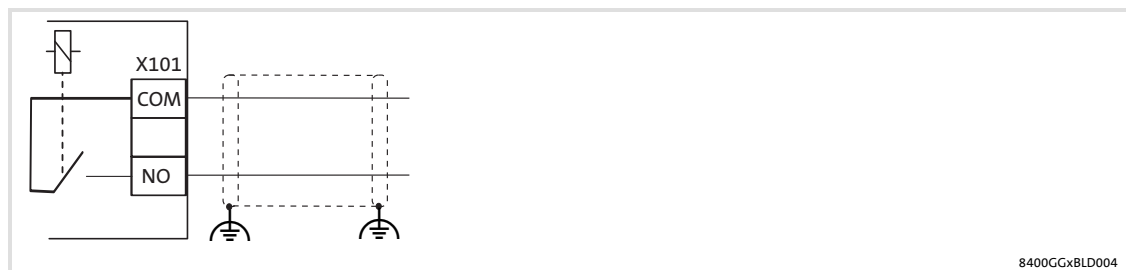

Fig. 6-22 Wiring of the relay output



Note!

- ▶ Switching of control signals:
 - Use shielded cables
 - HF-shield termination by PE connection
 - The minimum load for a correct through-connection of the relay contacts is 10 V DC and 10 mA. Both values must be exceeded at the same time.
- ▶ Use shielded cables for switching the control signals and establish the HF-shield termination through a PE connection.
- ▶ For the switching operation of mains potentials, shielded cables are sufficient.
- ▶ To protect the relay contacts, use a corresponding suppressor circuit in case of an inductive or capacitive load!
- ▶ The service life of the relay depends on the load type (ohmic, inductive, or capacitive) and the height of capacity to be switched.



Note!

The following notes are described in detail in the Software Manual in the section "I/O terminals":

- ▶ Use code C00621 to define the relay function.
- ▶ Use code C00118 to define the relay switching status.

6.5.7 Diagnostics

The BaseLine controllers can be parameterised and configured by using

- ▶ the integrated keypad with additional LEDs for status display.
- ▶ a USB diagnostic adapter that can be connected to diagnostic interface X6.

In combination with the Lenze PC software »Engineer«, the diagnostic adapter serves to make comprehensive settings via dialogs, e.g. for initial commissioning.

The integrated keypad can be used to check and change individual settings.

Socket X6	Labelling	Description
 <small>8400HLC009</small>	X6	Diagnostic interface for connection of a USB diagnostic adapter for online diagnostics

7 Commissioning

Before switching on

7 Commissioning



Note!

Please observe the general safety instructions and the residual hazards in chapter 2.1 and 2.3.

7.1 Before switching on



Note!

- ▶ Comply with the corresponding switch-on sequence.
- ▶ In case of faults during commissioning please use:
 - the online help in the »Engineer«
 - the software manual 8400 BaseLine D
 - the software manual 8400 BaseLine C

To prevent injury to persons or damage to material assets, check ...

... before connecting the mains voltage:

- ▶ Wiring for completeness, short circuit, and earth fault
- ▶ The "EMERGENCY STOP" function of the entire system
- ▶ The motor circuit configuration (star/delta) must be adapted to the output voltage of the controller
- ▶ The in-phase connection of the motor (rotational direction)

... the most important drive parameter settings before the controller is enabled:

- ▶ Is the V/f rated frequency adapted to the motor circuit configuration?
- ▶ Are the drive parameters relevant for your application set correctly?
- ▶ Is the configuration of the analog input and the digital inputs adapted to wiring?

7.2

Display elements and control panel

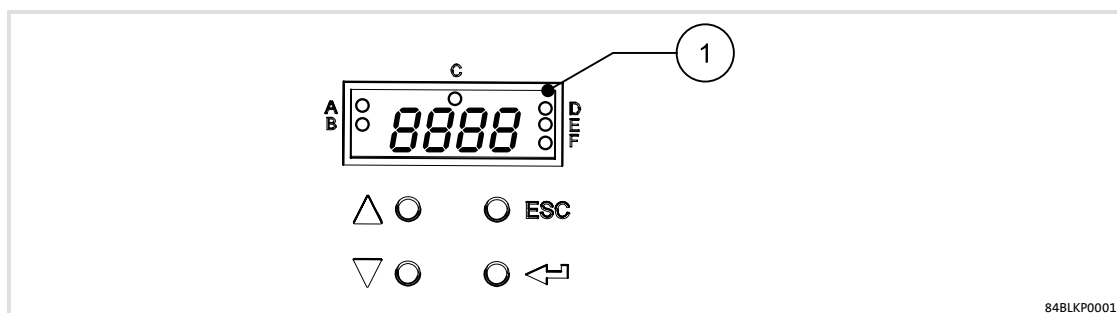

84BLKP0001

Pos.	Description
①	4-Character- Display with LEDs (A ... F)
A	orange Set current/torque limit is reached.
B	yellow Minus sign for identifying the negative numbers bigger than 3 characters
C	yellow User-LED- configured with C00621/42.
D	red see table below
E	green
	yellow Rotational direction CWW
F	off Rotational direction CW
	blinking Commanded direction is not equal to actual direction- for example during reversing.
ESC	ESC key Abort of the current operation
↵	Enter key Confirm and accept changes
▲	Navigation key, upwards Short pressing: navigation in the menu level and parameter level and parameter editing
▼	Navigation key, downwards Long pressing (> 2 seconds): fast scrolling function

The LEDs "D" and "E" have an additional signalling.





LED E (green)	LED D (red)	Status
OFF	OFF	→ "Init" state
	OFF	→ "ReadyToSwitchOn" state
	OFF	→ "SwitchedOn" state
■	OFF	→ "OperationEnabled" state
	█	→ "Warning" status display The controller is ready to switch on, switched on or operation is enabled and there is a warning pending.
OFF		→ "Trouble" state
OFF		→ "Fault" state
OFF	■	→ "SystemFail" state

Commissioning

Display elements and control panel

Legend

The symbols used for indicating the LED states have the following meaning:

	LED flashes once approx. every 3 seconds (slow flash)
	LED flashes once approx. every 1.25 seconds (flash)
	LED flashes twice approx. every 1.25 seconds (double flash)
	LED blinks every second
	LED is permanently on

7.3 Menu structure

**Note!**

- ▶ After switching on the controller, the integrated keypad performs a quick self-test. All segments of the display flash for approx. 2 seconds.

After that:

- ▶ if there is no fault the keypad displays *rdY* for 1 second.
 - If power-up start is disabled the keypad displays *00*.
 - if power-up start is enabled the keypad displays the limited setpoint speed of the motor. The integrated keypad is now operational.
- ▶ If there is a fault then the keypad displays the corresponding message.
- ▶ When the password protection is activated and no password is input, only the user menu is freely accessible. All other functions require the correct password.

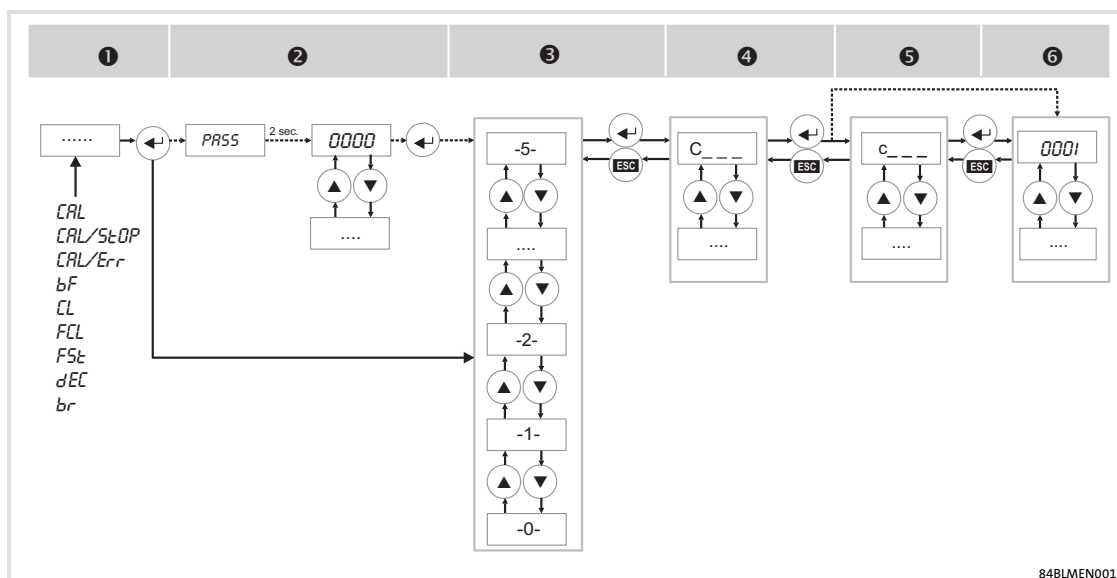
**Level**

- ① Status display
- ② Password request and password input
- ③ Menu level
- ④ Code level
- ⑤ Subcode level
- ⑥ Edit

Menu

- 0- Access all the parameters which the user has selected under C517 by themselves.
- 1- Access all drive parameters.
- 2- Access parameters for fast commissioning with terminal control.
- 3- Access parameters for fast commissioning with keypad control.
- 4- Access motor control parameters.
- 5- Access diagnostic parameters.

Commissioning

Preparing the commissioning procedure

7.4 Preparing the commissioning procedure

You need the following for commissioning:

- ▶ The integrated keypad
- ▶ Mains voltage

or

- ▶ Computer with Windows® operating system (XP or 2000)
- ▶ Lenze PC software »Engineer«
- ▶ Connection with the controller via an interface, e.g.
 - Diagnostic interface X6 with USB diagnostic adapter
- ▶ Software manual for the technology application used
- ▶ The communication manual for the network of the automation platform
- ▶ Mains voltage

Follow the instructions of the software and/or read the documentation.

7.5 Test commissioning



Danger!

The controller is a source of danger which may lead to death or severe injury of persons.

To protect yourself and others against these dangers, observe the safety instructions before switching on the controller.

Please read the safety instructions provided in the 8400 Mounting Instructions and in the 8400 Hardware Manual. Both documents are supplied with the controller.

Target

For test and demonstration purposes, the motor shall be rotated in best time with as few wiring complexity and settings.

Keypad or setpoint potentiometer

First decide how to control the controller during test commissioning:

- ▶ Test commissioning with keypad control
- ▶ Test commissioning with terminal control



Tip!

The use of the internal keypad is described in the corresponding software manual and in the hardware manual. The electronic version of the manuals can be found on the "L-force 8400 Inverter Drives" CD.

7

Commissioning

Test commissioning

Test commissioning with keypad control

7.5.1

Test commissioning with keypad control

Step-by-step commissioning

1. Wiring of power terminals

Make use of the "Electrical installation" chapter or the Mounting Instructions to wire the power terminals according to the requirements of your device.

2. Wiring of control terminals.

Digital inputs at terminal X4	Assignment	Information
	RFR	<ul style="list-style-type: none"> Controller enable RFR = High Error reset High → Low (edge-controlled)

3. If you can be sure that the frequency inverter is in the default state (Lenze setting), you can skip this commissioning step. If not, establish the Lenze setting of the frequency inverter as follows:

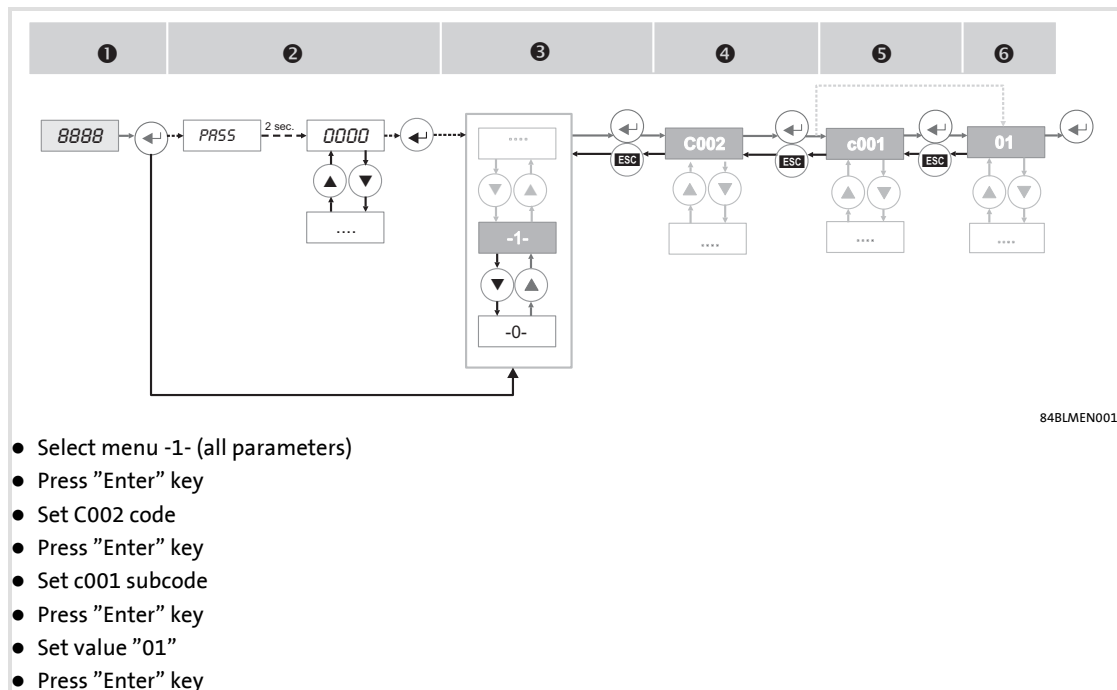

4. Set keypad control

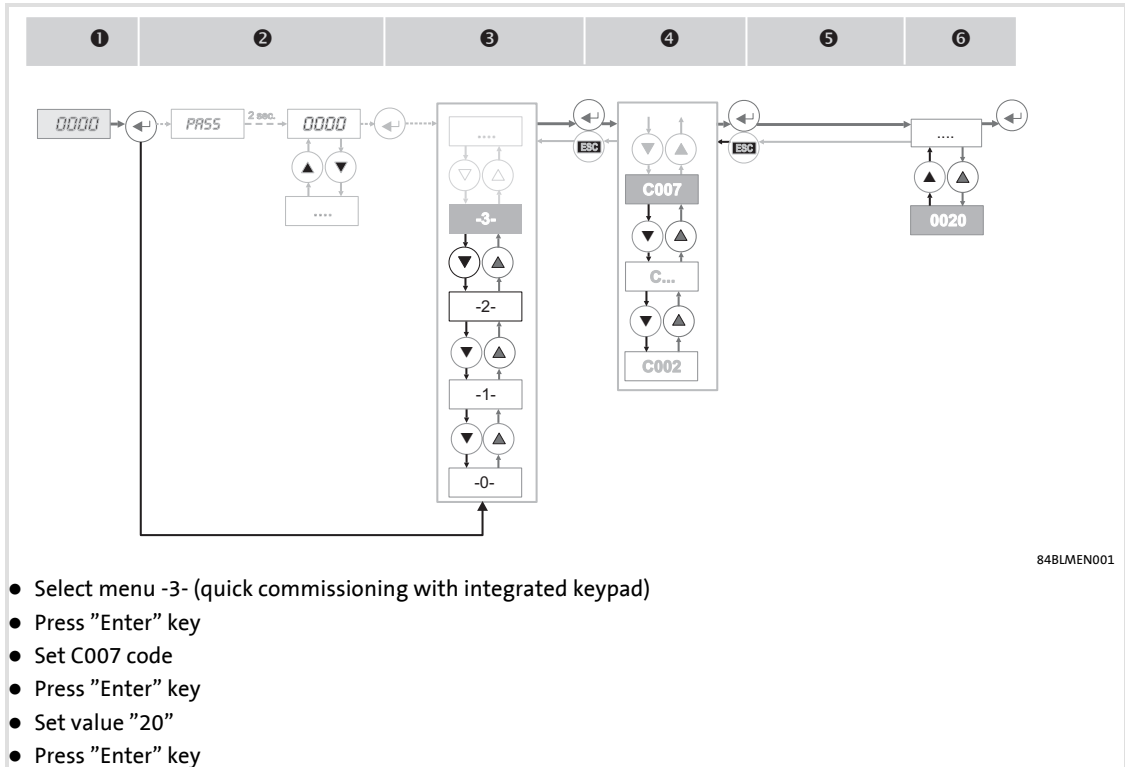

5. Enable controller:

Set terminal X4/RFR to HIGH-Potential (reference: X4/12I).

6. Vary the motor speed with the integrated keypad or by defining different fixed setpoints:

Internal Keypad	Code	Subcode	Motor speed
	C00728	3	Counter-clockwise rotation: -199.9 % ... 0 (from C00011) Clockwise rotation 0 ... +199.9 % (from C00011)
	C00051	-	Observe <ul style="list-style-type: none"> • the actual speed value: C00051 • appearing messages 92

7. Save the settings with mains failure protection by entering the value "1" in code C002, subcode 7.

7

Commissioning

Test commissioning

Test commissioning with terminal control

7.5.2 Test commissioning with terminal control

Step-by-step commissioning

1. Wiring of power terminals

Make use of the "Electrical installation" chapter or the Mounting Instructions to wire the power terminals according to the requirements of your device.

2. Wiring of control terminals.

Wiring of the analog input at X4	Assignment	Terminal control
	A1U	Setpoint selection 10 V (=100 %): 1500 rpm (for 4-pole motor)

Wiring of the digital inputs at X4	Assignment	Terminal control
	RFR	<ul style="list-style-type: none"> Controller enable: RFR = High Error reset: High → Low (edge-controlled)
DI1 ... DI4: all active = High	DI1	Fixed frequency 1 ... fixed frequency 3, see below table
	DI2	
	DI3	DCB
	DI4	Direction of rotation counter-clockwise/clockwise (CCW/CW)

3. If you can be sure that the frequency inverter is in the default state (Lenze setting), you can skip this commissioning step. If not, establish the Lenze setting of the frequency inverter as follows:

123456

- Select menu -1- (all parameters)
- Press "Enter" key
- Set C002 code
- Press "Enter" key
- Set c001 subcode
- Press "Enter" key
- Set value "01"
- Press "Enter" key



84BLMEN001

4. Enable controller:

Set terminal X4/RFR to HIGH-Potential (reference: X4/GND).

5. Vary the motor speed or the motor velocity with the potentiometer or by defining different fixed setpoints:

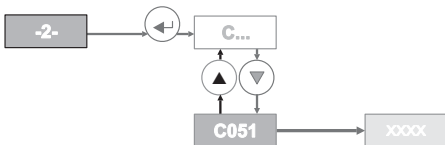
DI2	DI1	Motor speed
0	0	Setpoint by potentiometer
0	1	40 % of C00011 (reference speed)
1	0	60 % of C00011 (reference speed)
1	1	80 % of C00011 (reference speed)

Internal Keypad	Code	Subcode	Motor speed
	C00051	-	Observe <ul style="list-style-type: none"> the actual speed value: C00051 appearing messages  92

6. Save the settings with mains failure protection by entering the value "1" in code C002, subcode 7.

7 Commissioning Messages

7.6 Messages

The current status of the controller can be checked via:

- ▶ six LEDs in different colours (📖 83)
- ▶ messages as follows:

Message	Status	Meaning
<i>PASS</i>		Password input
<i>CRL</i>	blinking	Identification is in progress.
<i>CRL / StOP</i>	alternatively blinking	Identification is ready to start. Operation is not enabled yet.
<i>CRL / Err</i>	alternatively blinking	Identification is not ready to start. Either C00088, or C00089, or C00090 is 0.
<i>bF</i>	blinking	Identification error. Drive ID stored in EPM does not match the drive ID stored in the controller.
<i>CL</i>	constant	Current limit set by C00022 is reached
<i>FCL</i>	constant	Fast current limit value (higher than value of C00022) is reached
<i>FSt</i>	constant	Flying restart function is in progress
<i>dEC</i>	constant	Deceleration is temporarily suspended because of higher bus voltage
<i>br</i>	flashes during the hold time of the DC brake	DC brake is in progress

8 Braking operation

8.1 Braking operation without additional measures

Decelerating small masses

To decelerate small masses, the "DC injection brake DCB" functions can be parameterised. DC-injection braking enables a quick deceleration of the drive to standstill without using an external brake resistor.

- ▶ Code C00036 can be used to select the braking current.
- ▶ The maximum braking torque to be realised by the DC braking current amounts to approx. 20 ... 30 % of the rated motor torque. It is lower compared to braking action in generator mode with external brake resistor.
- ▶ Automatic DC-injection braking (Auto-DCB) improves the starting performance of the motor when the operation mode without speed feedback is used.

Further information on the relevant parameters can be obtained from the software manual.

8

Braking operation

Braking operation with external brake module

8.2

Braking operation with external brake module

Inverters with 230 V mains connection can be operated with external brake modules of type 9351. The modules can be used for frequent braking operations at low power levels or for rare braking operations at medium power levels.

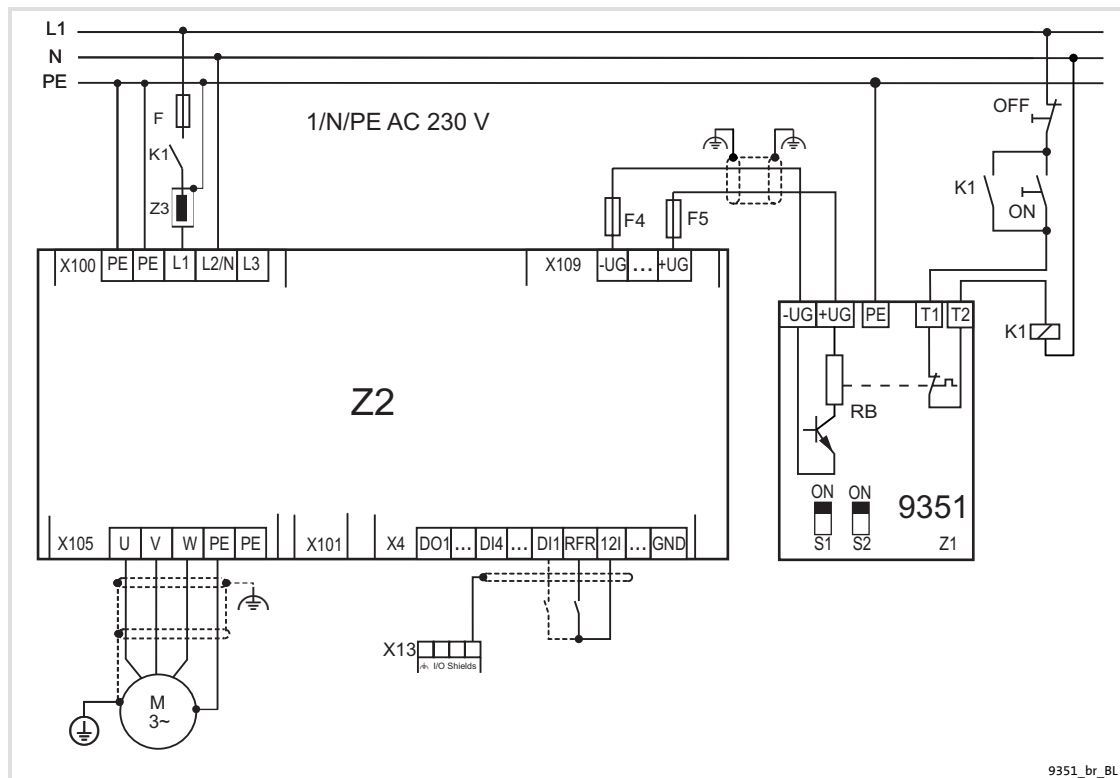

Fig. 8-1 Connection of 9351 brake module to 8400 Baseline controller

- Z1 Brake module
- Z2 Frequency inverter
- Z3 Mains choke
- K1 Mains contactor
- F Mains fuse
- F4, F5 DC-bus fuses (recommendation)
- DO1 The digital output is not available for devices with nameplate data E84AVBDxxxxSX0

Mains voltage [V_{rms}]	Switching threshold [V]	Switch position S1	Switch position S2
230	375	OFF	OFF
400 ... 460	725	ON	OFF
480¹⁾	765	ON	ON

¹⁾ Lenze setting in bold type

8.3 Braking operation with external brake resistor

To decelerate greater moments of inertia or with a longer operation in generator mode an external brake resistor is required. It converts braking energy into heat.

The brake resistor is connected if the DC-bus voltage exceeds the switching threshold. This prevents the controller from setting pulse inhibit through the "Overvoltage" fault and the drive from coasting. The external brake resistor serves to control the braking process at any time.

The E84AVBD...4 controllers are equipped with a brake chopper. The brake chopper switches in the external brake resistor.

- ▶ Adapt the switching threshold to the mains voltage (C00173/C00714, see software manual).

8

Braking operation

Braking operation with external brake resistor

Operation at rated mains voltage 400 V

8.3.1

Operation at rated mains voltage 400 VSwitching threshold V_{BRmax} : 725 V, adjustable

Type	R_{Bmin} [Ω]	I_{BRmax} [A]	P_{BRmax} [kW]	I_{BRd} [A]	P_{Bd} [kW]	t_z [s]	t_{on} [s]	t_{fp} [s]
E84AVBxx3714	390	1.9	1.3	1.9	1.3	-	∞	-
E84AVBxx5514	390	1.9	1.3	1.9	1.3	-	∞	-
E84AVBxx7514	390	1.9	1.3	1.9	1.3	-	∞	-
E84AVBxx1124	180	4.0	2.9	4.0	2.9	-	∞	-
E84AVBxx1524	180	4.0	2.9	4.0	2.9	-	∞	-
E84AVBxx2224	150	4.8	3.5	4.8	3.5	-	∞	-
E84AVBxx3024	100	7.3	5.3	7.3	5.3	-	∞	-

R_{Bmin}	Minimum brake resistance, nominal value $\pm 10\%$
I_{BRmax}	Peak current
P_{BRmax}	Peak braking power
I_{BRd}	Continuous current RMS - important for cable dimensioning
P_{Bd}	Continuous braking power
t_z	Cycle time, periodic load change with running time and recovery time
t_{on}	Running time in a cycle without reducing the scanning ratio (∞ = no time limit)
$t_z - t_{on}$	Recovery time
t_{fp}	Maximum running time without initial load and observing the recovery time

8.3.2 Operation at rated mains voltage 500 V

Switching threshold V_{BRmax} : 790 V, adjustable

Type	R_{Bmin} [Ω]	I_{BRmax} [A]	P_{BRmax} [kW]	I_{BRd} [A]	P_{Bd} [kW]	t_z [s]	t_{on} [s]	t_{fp} [s]
E84AVBxx3714	390	2.0	1.6	2.0	1.6	-	∞	-
E84AVBxx5514	390	2.0	1.6	2.0	1.6	-	∞	-
E84AVBxx7514	390	2.0	1.6	2.0	1.6	-	∞	-
E84AVBxx1124	180	4.4	3.5	4.4	3.5	-	∞	-
E84AVBxx1524	180	4.4	3.5	4.4	3.5	-	∞	-
E84AVBxx2224	150	5.3	4.2	5.3	4.2	-	∞	-
E84AVBxx3024	100	7.9	6.2	7.9	6.2	-	∞	-

R_{Bmin}	Minimum brake resistance, nominal value $\pm 10\%$
I_{BRmax}	Peak current
P_{BRmax}	Peak braking power
I_{BRd}	Continuous current RMS - important for cable dimensioning
P_{Bd}	Continuous braking power
t_z	Cycle time, periodic load change with running time and recovery time
t_{on}	Running time in a cycle without reducing the scanning ratio (∞ = no time limit)
$t_z - t_{on}$	Recovery time
t_{fp}	Maximum running time without initial load and observing the recovery time

8

Braking operation

Braking operation with external brake resistor

Selection of the brake resistors

8.3.3

Selection of the brake resistors

The recommended Lenze brake resistors are adapted to the corresponding controller (with regard to 150 % of regenerative power). They are suitable for most of the applications.

For special applications, e.g. centrifuges, the brake resistor must meet the following criteria:

Brake resistor Criterion	Application	
	With active load	With passive load
Continuous braking power [W]	$\geq P_{\max} \cdot \eta_e \cdot \eta_m \cdot \frac{t_1}{t_{\text{cycl}}}$	$\geq \frac{P_{\max} \cdot \eta_e \cdot \eta_m}{2} \cdot \frac{t_1}{t_{\text{cycl}}}$
Thermal capacity [Ws]	$\geq P_{\max} \cdot \eta_e \cdot \eta_m \cdot t_1$	$\geq \frac{P_{\max} \cdot \eta_e \cdot \eta_m}{2} \cdot t_1$
Resistor [Ω]	$R_{\min} \leq R \leq \frac{U_{\text{DC}}^2}{P_{\max} \cdot \eta_e \cdot \eta_m}$	

Active load Can start to move independent of the drive
(e.g. unwinder)

Passive load Can stop independent of the drive
(e.g. horizontal travelling drives, centrifuges, fans)

U_{DC} [V] Brake chopper switching threshold from C0174

P_{\max} [W] Maximum occurring braking power determined by the application

η_e Electrical efficiency (controller + motor)
Guide value: 0.54 (0.25 kW) ... 0.85 (11 kW)

η_m Mechanical efficiency (gearbox, machine)

t_1 [s] Braking time

t_{cycl} [s] Cycle time = time between two successive braking processes (= t_1 + dead time)

R_{\min} [Ω] Minimum permissible brake resistance (see rated data of the integrated brake chopper)

8.3.4 Rating for Lenze brake resistors

To decelerate greater moments of inertia or with a longer operation in generator mode an external brake resistor is required. It converts braking energy into heat.

The brake resistors (IP20) recommended in the table are designed for a 1.5-fold regenerative power. The cycle time is 150 s and contains a maximum braking time of 15 s and a minimum recovery time (break) of 135 s.

- ▶ The brake resistors are equipped with a thermostat (potential-free NC contact, switching capacity: AC 250 V, 0.5 A).
- ▶ To increase the power, brake resistors can be connected in parallel or in series.
 - The resistance for the controller must not fall below the lowest permissible value.
 - The thermostat of several brake resistors at a controller must always be connected in series.

Product key		Rated data - brake resistor		
Controller	Brake resistor	Resistor R [Ω]	Continuous power P [W]	Thermal capacity WK [kW \cdot s]
E84AVBxx3714	ERBM390R100W	390	100	15
E84AVBxx5514	ERBM390R100W			
E84AVBxx7514				
E84AVBxx1124	ERBP180R200W	180	200	30
E84AVBxx1524	ERBP180R200W			
E84AVBxx2224	ERBP180R300W		100	300
E84AVBxx3024	ERBP180R300W	300		45

Braking operation

Braking operation with external brake resistor
Wiring of brake resistor

8.3.5

Wiring of brake resistor



Danger!

Hazardous electrical voltage

During operation of the standard device and **up to 3 minutes after power-off** hazardous electrical voltages may occur at the terminals of the brake resistor.

Possible consequences:

- ▶ Death or severe injuries when touching the terminals.

Protective measures:

- ▶ Disconnect the standard device from the mains before working on the brake resistor.
- ▶ Check all power terminals for isolation from supply.
- ▶ Select the mounting location so that the operating conditions mentioned in the mounting instructions for the brake resistor are permanently guaranteed.



Danger!

Hot surface

The brake resistor may get very hot. (For temperatures see the mounting instructions for the brake resistor.)

Possible consequences:

- ▶ Severe burns when touching the brake resistor.
- ▶ Fire or smouldering fire if flammable material is placed near the brake resistor or may get to it.

Protective measures:

- ▶ Before working on the brake resistor, check its surface temperature.
- ▶ Select the mounting location so that the operating conditions mentioned in the mounting instructions for the brake resistor are permanently guaranteed.
- ▶ Protect the mounting location through fire prevention.

Protect the brake resistor and controller against destruction caused by overload:

- ▶ Establish a safety shutdown using the thermostat of the brake resistor to disconnect the controller from the mains.

Connecting cable version

- ▶ up to 0.5 m: twisted and unshielded
- ▶ from 0.5 to 5 m: shielded
 - Use shielded cables to meet the EMC requirements.

Wiring principle

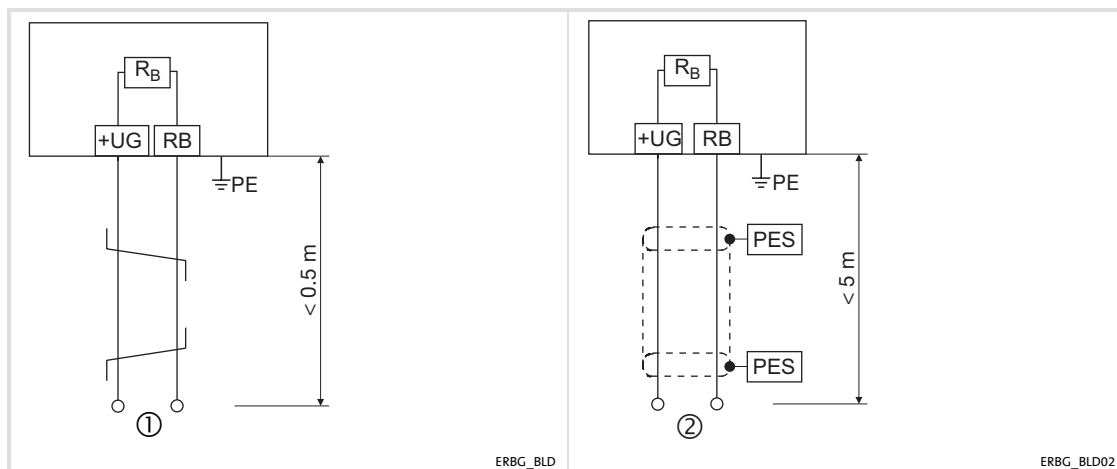

Fig. 8-2 Wiring of a brake resistor to the controller

PES

+UG, RB

①

②

HF-shield termination by PE connection via shield clamp

Terminals of the brake resistor

Supply cable to the controller with twisted pair wiring

Supply cable to the controller using shielding

(to be integrated e.g. into the latch circuit of the mains contactor of the supply)

8 Braking operation

Controlling the brake

Introduction

8.4 Controlling the brake

8.4.1 Introduction

Operation with spring-applied brake

Lenze three-phase AC motors and G-motion geared motors can be fitted with spring-applied brakes (motor holding brakes). An external motor brake control module is required for switching operation and DC supply of the spring-applied brakes.

The selection of the suitable motor brake control module is made depending on the rated data of the spring-applied brakes.

Switching the brake

The motor brake control module can be controlled by the relay output of the controller. The relay output must be parameterised accordingly. The brake can optionally be switched via an external control contact (e.g. PLC).

The software manual contains further information on parameterisation.

8.4.2

Rated data

► E82ZWBRB brake switch

Range	Values
Input voltage	1/N/PE AC 230 V (AC 180 ... 264 V), 45 ... 65 Hz 2/PE AC 230 V (AC 180 ... 264 V), 45 ... 65 Hz
Input current	AC 0.1 ... 0.54 A
Output voltage	DC 205 V at AC 230 V mains voltage
Maximum brake current	DC 0.41 A Installation in 8200 motec DC 0.54 A Installation in control cabinet
Control input	
Control voltage	DC 24 V, PLC-level HIGH DC +15 ... 30 V LOW DC 0 ... +3 V
Control current	5 ... 10 mA
Protective function	Protected against polarity reversal until DC 60 V
Maximally connectable cable cross-section	1.5 mm ² AWG 16

► E82ZWBRE brake switch

Range	Values
Input voltage	3/PE AC 400 V (AC 320 ... 550 V), 45 ... 65 Hz
Input current	AC 0.1 ... 0.61 A
Output voltage	DC 180 V at AC 400 V mains voltage DC 225 V at AC 500 V mains voltage
Maximum brake current	DC 0.47 A Installation in 8200 motec DC 0.61 A Installation in control cabinet
Control input	
Control voltage	DC 24 V, PLC-level HIGH DC +15 ... 30 V LOW DC 0 ... +3 V
Control current	5 ... 10 mA
Protective function	Protected against polarity reversal until DC 60 V
Min. permissible off time	t _{off} >20 ms
Maximally connectable cable cross-section	1.5 mm ²

8

Braking operation

Controlling the brake

Wiring

8.4.3

Wiring

► **E82ZWBRB brake switch**

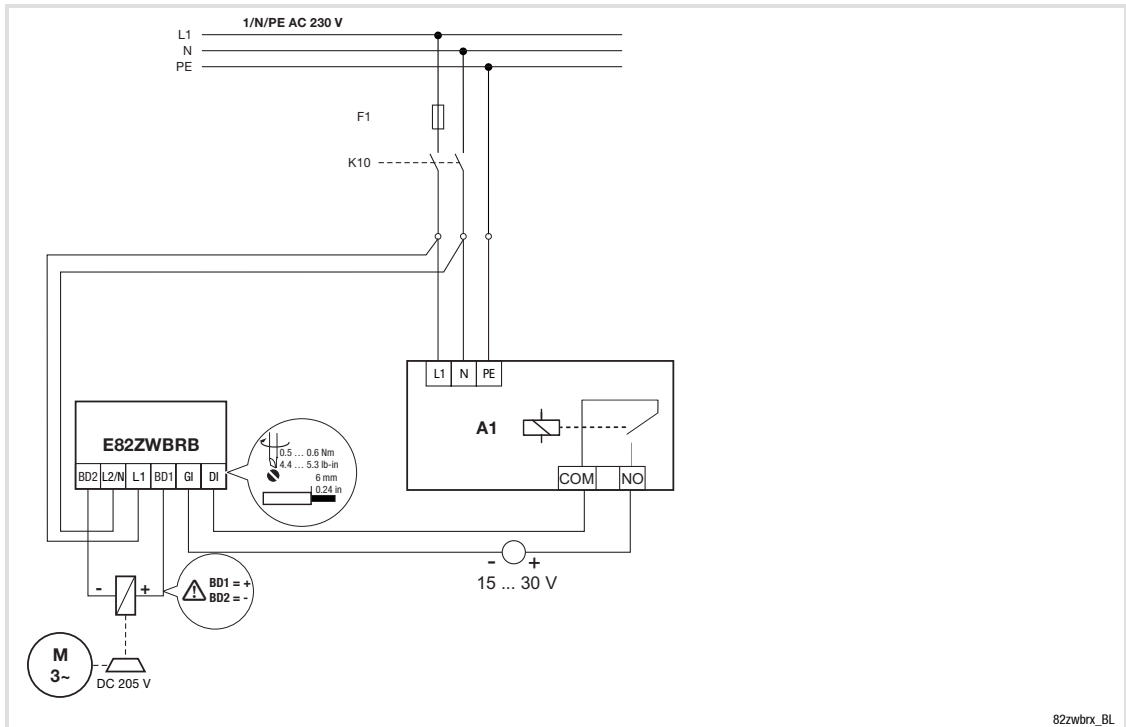

A1 Lenze controller with relay output

► **E82ZWBRE brake switch**

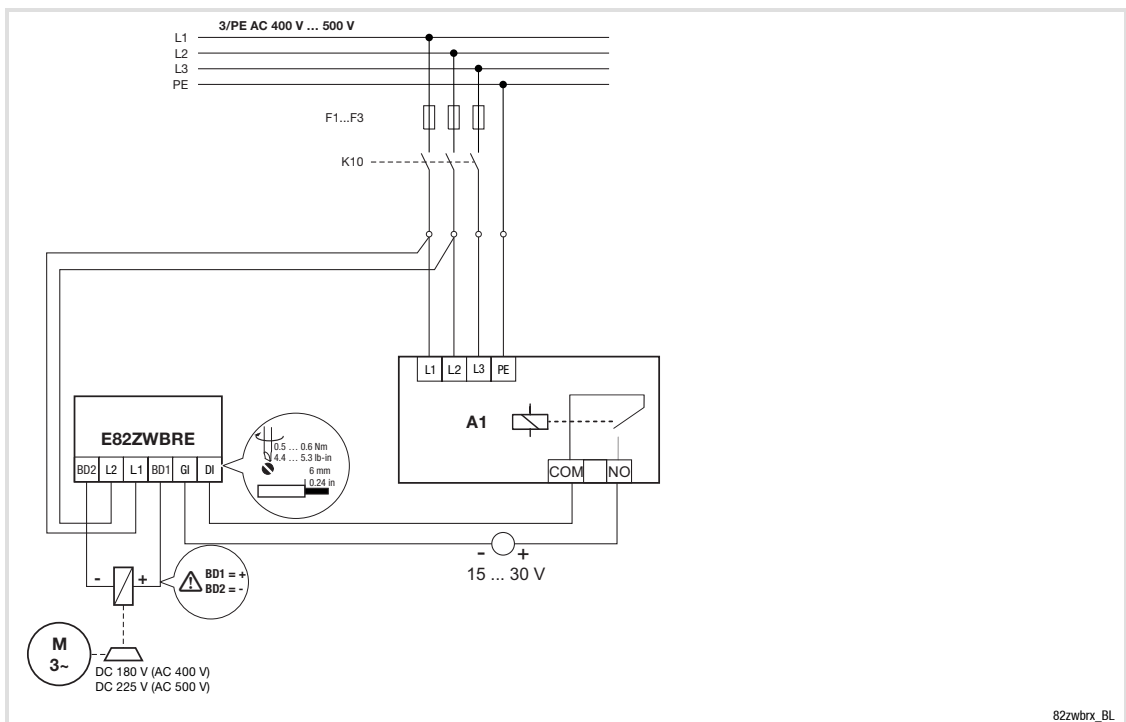

A1 Lenze controller with relay output

9 Accessories (overview)



Note!

More information on the accessories can be found in the catalog of this product series.

9.1 Overview

Coordinated accessories for 8400 L-force:

- ▶ Device modules - for different functional areas
 - EPM Memory module E84AYM20S
- ▶ USB diagnostic adapter E94AZCUS
 - Connecting cables EWL007x
- ▶ Motor holding brake control modules E82ZWBRx
- ▶ DC bus connection:
 - Type designation EWS0072 for devices operating at 230 V
 - Type designation EWS0073 for devices operating at 400 V to connect brake resistors ERBMxxxRxxxW/ERBPxxxRxxxW

9 Accessories (overview)

Mains chokes

9.2 Mains chokes

Assignment	
Type	Mains choke
E84AVBxx2512	ELN1-0900H005
E84AVBxx3712	
E84AVBxx5512	ELN1-0500H009
E84AVBxx7512	
E84AVBxx1122	ELN1-0250H018
E84AVBxx1522	
E84AVBxx2222	
E84AVBxx3714	ELN3-1500H003-001
E84AVBxx5514	
E84AVBxx7514	
E84AVBxx1124	ELN3-0680H006-001
E84AVBxx1524	
E84AVBxx2224	
E84AVBxx3024	ELN3-0250H013-001

9.3 External brake resistors

Product key		Rated data - brake resistor		
Controller	Brake resistor	Resistor R [Ω]	Continuous power P [W]	Thermal capacity WK [kWs]
E84AVBxx3714	ERBM390R100W	390	100	15
E84AVBxx5514	ERBM390R100W			
E84AVBxx7514				
E84AVBxx1124	ERBP180R200W	180	200	30
E84AVBxx1524	ERBP180R200W			
E84AVBxx2224	ERBP180R300W		100	300
E84AVBxx3024	ERBP180R300W	300		45

9 Accessories (overview)

Memory modules

9.4 Memory modules



Danger!

Risk of Electrical Shock

The EPM operates at high voltage relative to earth ground.

Possible consequences:

- ▶ Death or severe injuries

Protective measures:

- ▶ Do not unplug EPM with power applied to the drive.
- ▶ Do not apply power to the drive, if the EPM is not installed.

Name: EPM

Type designation: E84AYM20S

Slot: EPM

The parameters of the controller are stored in the memory module (EPM).

The pluggable memory module provides the following features:

- ▶ Recovery of an application after device exchange by plugging the EPM into the replacement drive.
- ▶ Duplication of identical applications in a series of identical drives using the optional EPM Programmer.

To remove/replace the memory module:

1. Insure power is removed from drive. Wait 180 seconds to insure internal voltages have decayed.
2. Remove security tape covering EPM module.
3. To remove the EPM, grasp it in the two notches with a pair of needle nose pliers or other similar tool. Gently pull it straight out.
4. Place new or modified EPM in the socket and gently press it straight in.
5. Replace security tape over the reinstalled EPM.
6. Apply power to the drive. The parameters in the EPM will automatically take effect upon power up.

**Stop!**

The device contains components that can be destroyed by electrostatic discharge!

Before working on the device, the personnel must ensure that they are free of electrostatic charge by using appropriate measures.

**Note!**

Only **grey** memory modules may be used for the inverters of the BaseLine series.

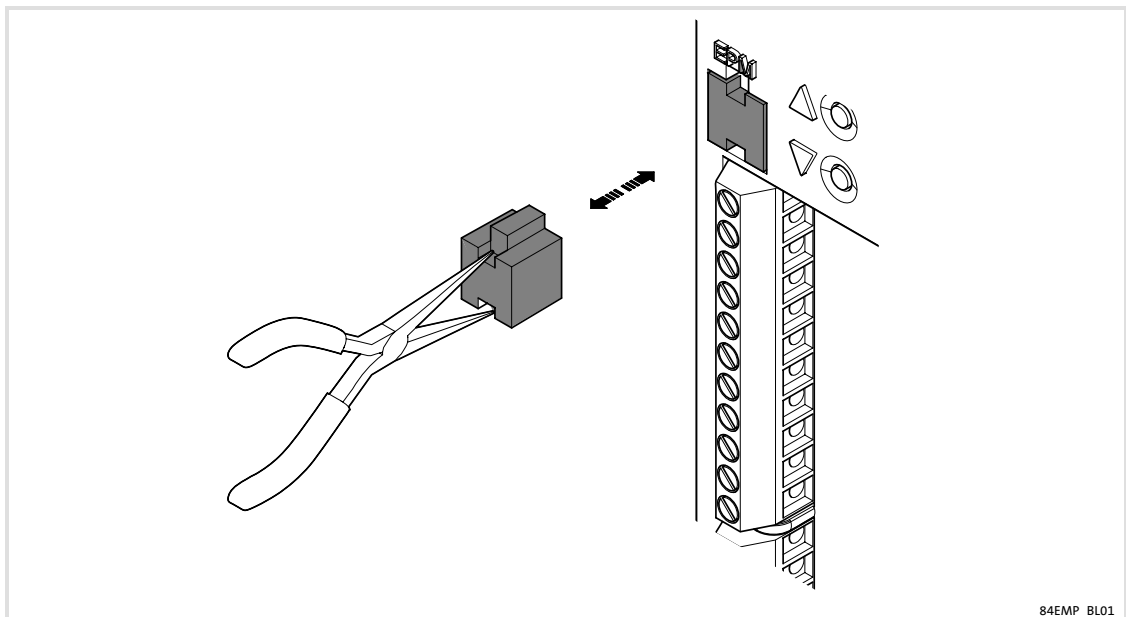

9 Accessories (overview)

Keypad

9.5 Keypad

The integrated keypad makes local parameter setting and diagnostics easy. Data can be accessed quickly via structured menus and the plain text display.

Features

- ▶ Menu-driven diagnostics and parameter setting
- ▶ 2 navigation keys, 2 context-sensitive keys

10 Appendix**10.1 Total index****A**

Accessories, 105

External brake resistor, 95

Analog input, 41 , 75

Assembly, standard installation, 44

B

Brake resistor, 99

Selection, 98

Wiring, 100

Braking, 93

Braking operation, 93

With external brake resistor, 95

without additional measures, 93

C

Cable

For control connections, 54

For motor connection, 53

Cables

cross-sections, 27 , 32 , 35

fuses, 27 , 32 , 35

Commissioning, 82

before switching on, 82

Contactors, in the motor cable, 15

Control cable, 54

Control terminals, 40 , 72

Controlling the brake, 102

D

DC bus, connection to the, 69

DC supply, 52

DC-bus operation, 20

Definition of notes used, 8

Device protection, 15 , 72 , 109

Diagnostics, 81

Digital inputs, 42 , 78

Digital outputs, 42 , 78

Disposal, 11

Drive behaviour, Influence of the motor cable length, 48

E

Electrical installation, 45

Relay output connection, 42 , 80

EMC, what to do in case of interferences, 59

EN 61000-3-2, 22

F

Fuses, 27 , 32 , 35
 operation with rated power, 400 V (UL), 27 , 28
 , 32 , 35

H

Harmonic currents, limitation according to EN
 61000-3-2, 22

I

Installation, electrical, 45
 Installation, mechanical, 43
 Interferences, eliminating EMC interferences, 59

K

Keypad, 110

M

Mains chokes, 106
 Mains connection, 52
 Mains current
 with external mains choke, 26 , 29 , 33
 with/without mains choke, 26 , 29 , 33
 Mechanical installation, 43
 Memory modules, 108
 Motor cable, 53
 capacitance per unit length, 21
 contactors in the, 15
 influence of the length, 48
 requirements, 21

Motor connection, 65
 Motor end, switching on the, 15
 Motor power, typical, 26 , 29 , 33
 Motor protection, 15

N

Noise emission, 22
 Noise immunity, 22
 Notes, definition, 8

O

Operation, overcurrent, 36
 Output power, 26 , 29 , 33
 output voltage, reduced, 25
 output voltage , 25
 Overspeeds, 15
 Overview
 Accessories, 105
 devices, 17
 terminals, 39

P

Parameter set transfer, 15
 Parameterisation, controlling the brake, 102
 Product description, 16
 Protection of persons, 15

R

Rated data, 103

Rating, Brake resistors, 99

Relay output, Connection, 42 , 80

Requirements, motor cable, 21

Residual hazards, 15

S

Safety instructions, 9

definition, 8

layout, 8

Shield and connect cables, 73

Step-by-step commissioning, 88 , 90

Strip cables, 61 , 67 , 73

Supply voltage, 24 V external, 40 , 77

Switch-on, check before switching on, 82

Switching on the motor side, 15

System bus (CANopen), 74

T

Technical data, 20

Terminals, 39

Test commissioning

with keypad control, 88

with terminal control, 90

Total index, 111

V

Validity, documentation, 6

W

Wiring, Brake resistor, 100



© 03/2009



AC Technology Corporation
630 Douglas Street
Uxbridge, MA 01569
USA



+1 508 / 278-9100



+1 508 / 278-78 73



info@actechdrives.com



www.Lenze-actech.com

Service

Lenze Service GmbH
Breslauer Straße 3
D-32699 Extertal
Germany



00 80 00 / 24 4 68 77 (24 h helpline)



+49 (0)51 54 / 82-11 12



Service@Lenze.de

EDS84ABD302 ■ 13291897 ■ EN ■ 4.0 ■ TD03

10 9 8 7 6 5 4 3 2 1