

SMVector PROFIBUS-DP Communication Module
Communications Interface Reference Guide

About These Instructions

This documentation applies to the optional PROFIBUS-DP communications module for the SMVector inverter and should be used in conjunction with the SMVector Operating Instructions (Document SV01) that shipped with the drive. These documents should be read carefully as they contain important technical data and describe the installation and operation of the drive.

© 2007 AC Technology Corporation

No part of this documentation may be copied or made available to third parties without the explicit written approval of AC Technology Corporation. All information given in this documentation has been carefully selected and tested for compliance with the hardware and software described. Nevertheless, discrepancies cannot be ruled out. AC Tech does not accept any responsibility nor liability for damages that may occur. Any necessary corrections will be implemented in subsequent editions.

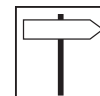

Contents

| | | |
|-------|--|----|
| 1 | Safety Information..... | 1 |
| 1.1 | Warnings, Cautions and Notes | 1 |
| 1.1.1 | General | 1 |
| 1.1.2 | Application | 1 |
| 1.1.3 | Installation | 1 |
| 1.1.4 | Electrical Connection..... | 2 |
| 1.1.5 | Operation | 2 |
| 2 | Introduction..... | 3 |
| 2.1 | Fieldbus Overview | 3 |
| 2.2 | Module Specification | 3 |
| 2.3 | Module Identification Label | 3 |
| 3 | Installation | 4 |
| 3.1 | Mechanical Installation | 4 |
| 3.2 | PROFIBUS-DP Terminal Block..... | 5 |
| 3.3 | Electrical Installation..... | 6 |
| 3.3.1 | Cable Types | 6 |
| 3.3.2 | Network Limitations | 6 |
| 3.3.3 | Connections and Shielding | 7 |
| 3.3.4 | Network Termination..... | 7 |
| 4 | Commissioning | 9 |
| 4.1 | Overview | 9 |
| 4.2 | Configuring the Network Master | 9 |
| 4.2.1 | Master Support Files | 9 |
| 4.2.2 | PROFIBUS-DP Master Setup Procedure | 9 |
| 4.3 | Configuring the SMV PROFIBUS-DP Module | 10 |
| 4.3.1 | Connecting..... | 10 |
| 4.3.2 | Setting the Network Protocol | 10 |
| 4.3.3 | Node Address..... | 10 |
| 4.3.4 | Baud / Data Rate | 11 |
| 4.3.5 | Data Mapping..... | 11 |
| 4.3.6 | Re-Initialising | 12 |
| 4.3.7 | Check Node Status..... | 12 |
| 4.3.8 | Non-Module Parameter Settings..... | 12 |



Contents

| | | |
|--------|--|----|
| 5. | Cyclic Data Access | 13 |
| 5.1 | What is Cyclic Data? | 13 |
| 5.2 | Mapping Cyclic Data | 13 |
| 5.2.1 | Data OUT (Dout) Channels | 13 |
| 5.2.2 | Data IN (Din) Channels | 14 |
| 5.3 | Channel Data Size..... | 15 |
| 5.4 | Cyclic Data | 16 |
| 5.4.1 | Overview | 16 |
| 5.4.2 | P44x = 1, SMV Control Word | 16 |
| 5.4.3 | P44x = 2, Network Frequency Setpoint | 17 |
| 5.4.4 | P44x = 3, Lenze C135 Control Word..... | 18 |
| 5.4.5 | P44x = 4 or 7, Network Speed Setpoint..... | 19 |
| 5.4.6 | P44x = 5, Network PID Setpoint | 19 |
| 5.4.7 | P44x = 6, Network Torque Setpoint..... | 19 |
| 5.4.8 | P44x = 8, Network Digital I/O Control Word | 20 |
| 5.4.9 | P44x = 9, Network Analog I/O Control Value..... | 20 |
| 5.4.10 | P46x = 1, SMV Status Word | 21 |
| 5.4.11 | P46x = 2, Actual Frequency | 21 |
| 5.4.12 | P46x = 3, Lenze C150 Status Word | 22 |
| 5.4.13 | P46x = 4, Actual Speed in RPMs | 22 |
| 5.4.14 | P46x = 5, Auxiliary Status | 23 |
| 5.4.15 | P46x = 6, Drive RUN Status..... | 24 |
| 5.4.16 | P46x = 7, Drive Fault Status..... | 24 |
| 5.4.17 | P46x = 8, Digital I/O Status | 26 |
| 5.4.18 | P46x = 9, Analog 0-10V Input | 26 |
| 5.4.19 | P46x = 10, Analog 4-20mA Input | 26 |
| 5.4.20 | P46x = 11, Actual PID Setpoint | 26 |
| 5.4.21 | P46x = 12, Actual PID Feedback | 26 |

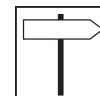

Contents

| | | |
|-------|---|----|
| 6. | Acyclic Parameter Access | 27 |
| 6.1 | What is Acyclic Data? | 27 |
| 6.2 | Setting the Acyclic Mode..... | 27 |
| 6.2.1 | Acyclic Modes | 27 |
| 6.2.2 | Acyclic Mode 1 | 27 |
| 6.2.3 | Acyclic Mode 2..... | 27 |
| 6.3 | Modes 1 & 2 - 4WPA Format..... | 28 |
| 6.3.1 | 4WPA - Function Code (Byte 0)..... | 28 |
| 6.3.2 | 4WPA - Access Control and Status (Byte 1) | 29 |
| 6.3.3 | 4WPA - Parameter Number (Bytes 2 & 3) | 29 |
| 6.3.4 | 4WPA - Sub-Index (Byte 4) | 30 |
| 6.3.5 | 4WPA - Data Word (Bytes 5 & 6)..... | 30 |
| 6.3.6 | 4WPA - Reserved (Byte 7) | 30 |
| 6.4 | Acyclic Parameter Access Examples | 30 |
| 7 | Advanced Features..... | 33 |
| 7.1 | Option Module Advanced Parameters..... | 33 |
| 7.1.1 | Module Revision | 33 |
| 7.1.2 | Module Status | 33 |
| 7.1.3 | Restore Defaults..... | 33 |
| 7.1.4 | Module Time-out Action | 34 |
| 7.1.5 | Module Firmware | 34 |
| 7.1.6 | Module Internal Code | 34 |
| 7.1.7 | Missed Messages..... | 34 |
| 7.2 | Network Fault | 35 |
| 7.3 | Master Monitor | 35 |
| 7.3.1 | Master Monitoring Time-out | 35 |
| 7.3.2 | Master Monitoring Time-out Action | 35 |
| 7.4 | Data Exchange..... | 36 |
| 7.4.1 | Data Exchange Time-out | 36 |
| 7.4.2 | Data Exchange Time-out Action..... | 36 |
| 7.4.3 | Data Exchange Frequency | 36 |
| 7.4.4 | Data Exchange Counter | 36 |



Contents

| | | |
|-----|--------------------------------------|----|
| 7.5 | Node Address Lock..... | 37 |
| 7.6 | Sync and Freeze | 37 |
| | 7.6.1 Sync and Freeze Overview | 37 |
| | 7.6.2 Sync and Freeze Status..... | 38 |
| 7.7 | Data Sizes | 38 |
| | 7.7.1 Dout Data Size | 38 |
| | 7.7.2 Din Data Size | 38 |
| 7.8 | Debug Data Viewer | 38 |
| | 7.8.1 Dout Data Monitor Select..... | 38 |
| | 7.8.2 Dout Data Monitor Value..... | 39 |
| | 7.8.3 Din Data Monitor Select..... | 39 |
| | 7.8.4 Din Data Monitor Value..... | 39 |
| 8 | Diagnostics | 40 |
| | 8.1 Faults | 40 |
| | 8.2 Troubleshooting..... | 40 |
| 9. | Parameter Quick Reference..... | 41 |

Safety Information



1 Safety Information

1.1 Warnings, Cautions and Notes

1.1.1 General

Some parts of Lenze controllers (frequency inverters, servo inverters, DC controllers) can be live, moving and rotating. Some surfaces can be hot.

Non-authorized removal of the required cover, inappropriate use, and incorrect installation or operation creates the risk of severe injury to personnel or damage to equipment.

All operations concerning transport, installation, and commissioning as well as maintenance must be carried out by qualified, skilled personnel (IEC 364 and CENELEC HD 384 or DIN VDE 0100 and IEC report 664 or DIN VDE0110 and national regulations for the prevention of accidents must be observed).

According to this basic safety information, qualified skilled personnel are persons who are familiar with the installation, assembly, commissioning, and operation of the product and who have the qualifications necessary for their occupation.

1.1.2 Application

Drive controllers are components designed for installation in electrical systems or machinery. They are not to be used as appliances. They are intended exclusively for professional and commercial purposes according to EN 61000-3-2. The documentation includes information on compliance with EN 61000-3-2.

When installing the drive controllers in machines, commissioning (i.e. the starting of operation as directed) is prohibited until it is proven that the machine complies with the regulations of the EC Directive 98/37/EC (Machinery Directive); EN 60204 must be observed.

Commissioning (i.e. starting drive as directed) is only allowed when there is compliance to the EMC Directive (89/336/EEC).

The drive controllers meet the requirements of the Low Voltage Directive 73/23/EEC. The harmonised standards of the series EN 50178/DIN VDE 0160 apply to the controllers.

The availability of controllers is restricted according to EN 61800-3. These products can cause radio interference in residential areas. In the case of radio interference, special measures may be necessary for drive controllers.

1.1.3 Installation

Ensure proper handling and avoid excessive mechanical stress. Do not bend any components and do not change any insulation distances during transport or handling. Do not touch any electronic components and contacts. Controllers contain electrostatically sensitive components, which can easily be damaged by inappropriate handling. Do not damage or destroy any electrical components since this might endanger your health! When installing the drive ensure optimal airflow by observing all clearance distances in the drive's user manual. Do not expose the drive to excessive: vibration, temperature, humidity, sunlight, dust, pollutants, corrosive chemicals or other hazardous environments.



Safety Information

1.1.4 Electrical Connection

When working on live drive controllers, applicable national regulations for the prevention of accidents (e.g. VBG 4) must be observed.

The electrical installation must be carried out in accordance with the appropriate regulations (e.g. cable cross-sections, fuses, PE connection). Additional information can be obtained from the regulatory documentation.

The regulatory documentation contains information about installation in compliance with EMC (shielding, grounding, filters and cables). These notes must also be observed for CE-marked controllers.

The manufacturer of the system or machine is responsible for compliance with the required limit values demanded by EMC legislation.

1.1.5 Operation

Systems including controllers must be equipped with additional monitoring and protection devices according to the corresponding standards (e.g. technical equipment, regulations for prevention of accidents, etc.). You are allowed to adapt the controller to your application as described in the documentation.



DANGER!

- After the controller has been disconnected from the supply voltage, do not touch the live components and power connection until the capacitors have discharged. Please observe the corresponding notes on the controller.
- Do not continuously cycle input power to the controller more than once every three minutes.
- Close all protective covers and doors during operation.



WARNING!

Network control permits automatic starting and stopping of the inverter drive. The system design must incorporate adequate protection to prevent personnel from accessing moving equipment while power is applied to the drive system.

Table 1: Pictographs used in these instructions

| Pictograph | Signal word | Meaning | Consequences if ignored |
|------------|-----------------|--|--|
| | DANGER! | Warning of Hazardous Electrical Voltage. | Reference to an imminent danger that may result in death or serious personal injury if the corresponding measures are not taken. |
| | WARNING! | Impending or possible danger for persons | Death or injury |
| | STOP! | Possible damage to equipment | Damage to drive system or its surroundings |
| | NOTE | Useful tip: If observed, it will make using the drive easier | |



Introduction

2 Introduction

The following information is provided to explain how the SMV Series drive operates on a PROFIBUS network; it is not intended to explain how PROFIBUS itself works. Therefore, a working knowledge of PROFIBUS is assumed, as well as familiarity with the operation of the SMV Series drive.

2.1 Fieldbus Overview

PROFIBUS-DP Fieldbus is an internationally accepted communications protocol designed for commercial and industrial installations of factory automation and motion control applications. High data transfer rates combined with its efficient data formatting, permit the coordination and control of multi-node applications.

2.2 Module Specification

- Auto detection of data rates
- Supported baudrates: 12Mbps, 6Mbps, 3Mbps, 1.5Mbps, 500kbps, 187.5kbps, 93.75kbps, 45.45kbps, 19.2kbps, 9.6kbps.
- Scalable amount of input and output process data words (maximum of 6 in either direction).
- Parameter access data channel

2.3 Module Identification Label

Figure 1 illustrates the labels on the SMV PROFIBUS-DP communications module. The SMVector PROFIBUS-DP module is identifiable by:

- Two labels affixed to either side of the module.
- The color coded identifier label in the center of the module.

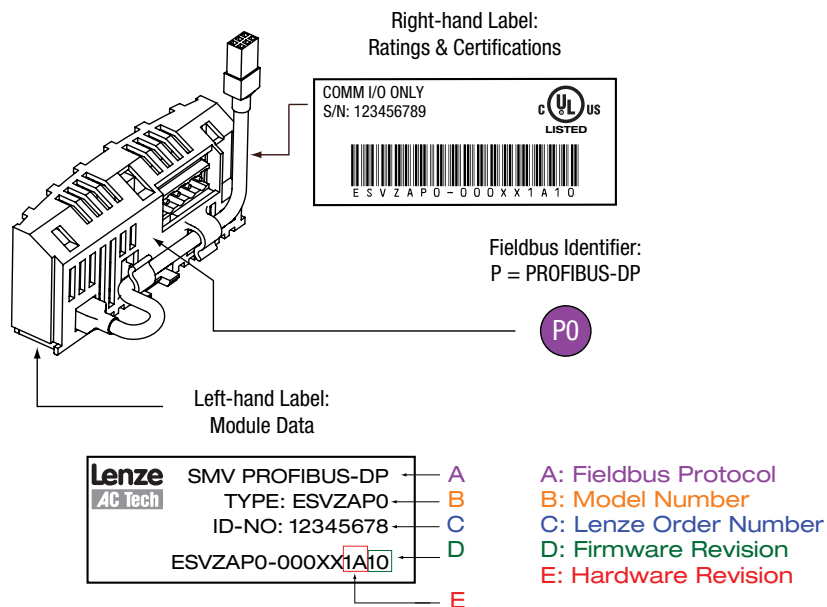

Figure 1: PROFIBUS Module Labels



Installation

3 Installation

3.1 Mechanical Installation

1. Ensure that for safety reasons the AC supply has been disconnected before opening the terminal cover.
2. Insert the PROFIBUS option module in the terminal cover and securely “click” into position as illustrated in Figure 2.
3. Wire the network cables as detailed in paragraph 3.3, *Electrical Installation*, to the connector provided and plug the connector into the option module.
4. Align terminal cover for re-fitting, connect the module umbilical cord to the drive then close the cover and secure, as shown in Figure 3.

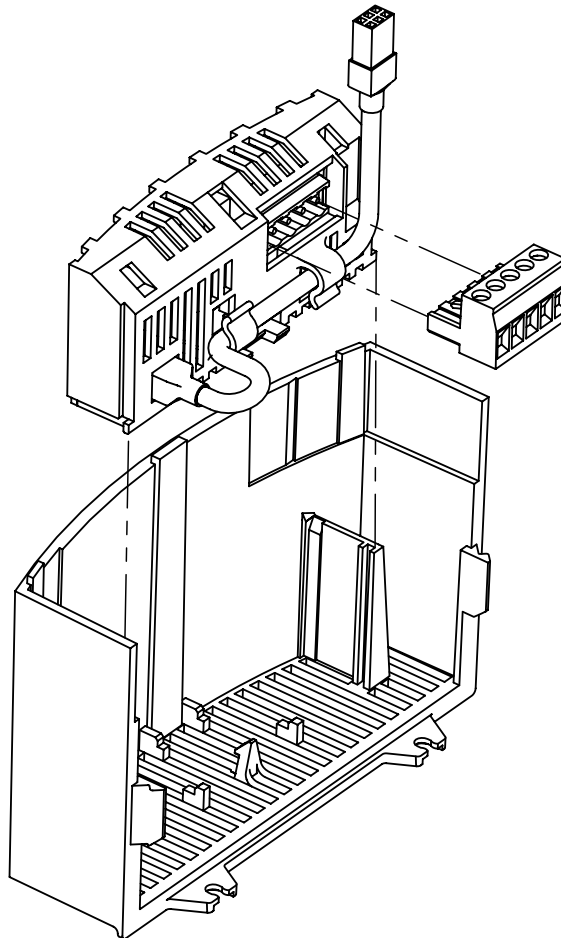

Figure 2: Installing the PROFIBUS-DP Communications Module

Installation

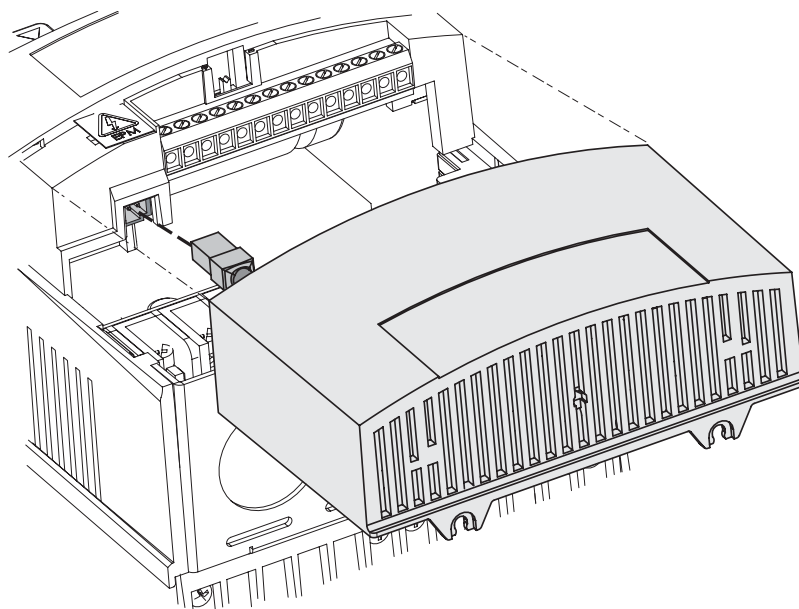

Figure 3: Re-Installing the Terminal Cover

3.2 PROFIBUS-DP Terminal Block

Table 2 identifies the terminals and describes the function of each. Figure 4 illustrates the PROFIBUS-DP 5 pole 5mm pluggable connector.

Table 2: PROFIBUS-DP Terminals

| Terminal | Function | Description |
|----------|-----------|----------------------------------|
| 1 | 0V Is0 | Isolated 0V |
| 2 | RxD/TxD-N | Negative data line IN (A) Green |
| 3 | RxD/TxD-P | Positive data line IN (B) Red |
| 4 | RxD/TxD-N | Negative data line OUT (A) Green |
| 5 | RxD/TxD-P | Positive data line OUT (B) Red |

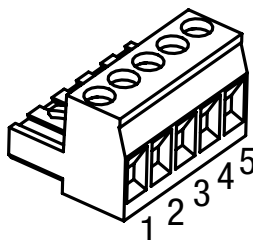

Figure 4: PROFIBUS-DP Connector



NOTE

The SMV PROFIBUS-DP module is equipped with an integrated termination switch and inductors for operation above 1.5Mbps. Some other PROFIBUS-DP devices require a D sub-type connector to achieve this termination.



Installation

3.3 Electrical Installation

3.3.1 Cable Types

Due to the high data rates used on PROFIBUS-DP networks it is paramount that correctly specified quality cable is used. The use of low quality cable will result in excess signal attenuation and data loss. Cable specifications and approved manufacturers are available from the official PROFIBUS website at: <http://www.profibus.com>

3.3.2 Network Limitations

There are several limiting factors that must be taken into consideration when designing a PROFIBUS-DP network, for full details refer to the official “Installation Guidelines for PROFIBUS-DP/FMS” which is available from <http://www.profibus.com>. However, here is a simple checklist:

- PROFIBUS-DP networks are limited to a maximum of 125 nodes.
- Only 32 nodes may be connected on a single network segment.
- A network may be built up from one or several segments with the use of network repeaters.
- Maximum total network length is governed by the data rate used. Refer to Table 3.
- Minimum of 1 meter of cable between nodes.
- Use fiber optic segments to:
 - Extend networks beyond normal cable limitations.
 - Overcome different ground potential problems.
 - Overcome very high electromagnetic interference.
- Spurs or T connections are only acceptable by the PROFIBUS-DP specification when operating at data rates of 1.5Mbps or less, however it is strongly advised not to use spurs as extreme care must be taken during the network design phase to avoid problems.

Table 3: Standard “Type A” Cable Network Length Specifications

| Baud Rate | Maximum Segment Length | Recommended Maximum Total Network Length |
|-----------|------------------------|--|
| 9.6kbps | 1200 meters | 6000 meters |
| 19.2kbps | 1200 meters | 6000 meters |
| 45.45kbps | 1200 meters | 6000 meters |
| 93.75kbps | 1200 meters | 6000 meters |
| 187.5kbps | 1000 meters | 5000 meters |
| 500kbps | 400 meters | 2000 meters |
| 1.5Mbps | 200 meters | 1000 meters |
| 3Mbps | 100 meters | 500 meters |
| 6Mbps | 100 meters | 500 meters |
| 12Mbps | 100 meters | 500 meters |



NOTE

The recommended maximum network length is achievable with the use of repeaters. Due to signal propagation delay within the repeaters it is recommended that no more than 4 repeaters be used between any two network nodes

Installation

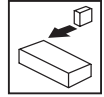

3.3.3 Connections and Shielding

To ensure good system noise immunity all networks cables should be correctly grounded:

- Minimum grounding recommendation: ground the network cable once in every cubical.
- Ideal grounding recommendation: ground the network cable on or as near to each drive as possible.
- For wiring of cable to the connector plug the unscreened cable cores should be kept as short as possible; recommended maximum of 20mm. The shield connection of terminal 1 should also be wired to earth (PE).

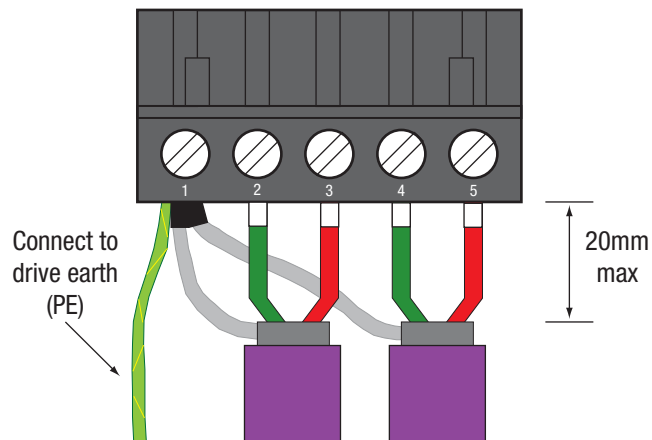

Figure 6: Connector Wiring Diagram

3.3.4 Network Termination

In high speed fieldbus networks such as PROFIBUS-DP it is essential to install the specified termination resistors, i.e. one at both ends of a network segment. Failure to do so will result in signals being reflected back along the cable which will cause data corruption.

The SMV PROFIBUS-DP module is equipped with integrated termination resistors, and can be switched into the network by setting SW1 to the ON position as shown in Figure 7.

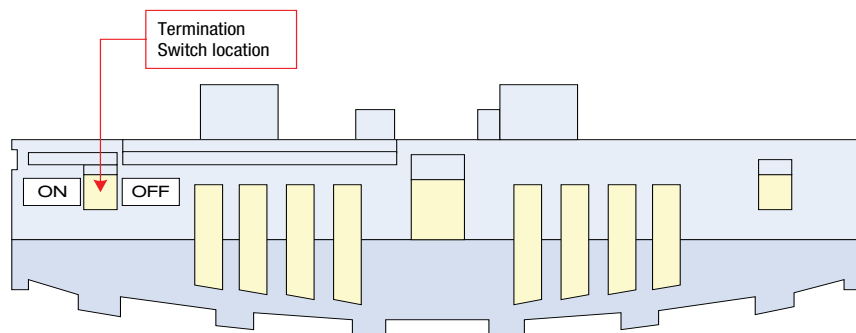

Figure 7: Module Network Termination Switch



Installation

PROFIBUS-DP uses active (powered) termination. Therefore it is strongly recommended that "stand alone" active termination units are used to maintain the integrity of the network. If the SMV is used to provide network termination, in the event of a power loss to the drive, network termination will also be lost.

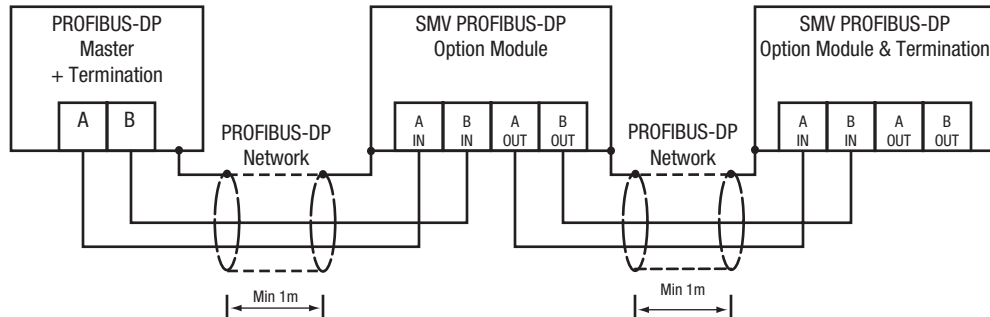

Figure 8a: Network without Active Termination

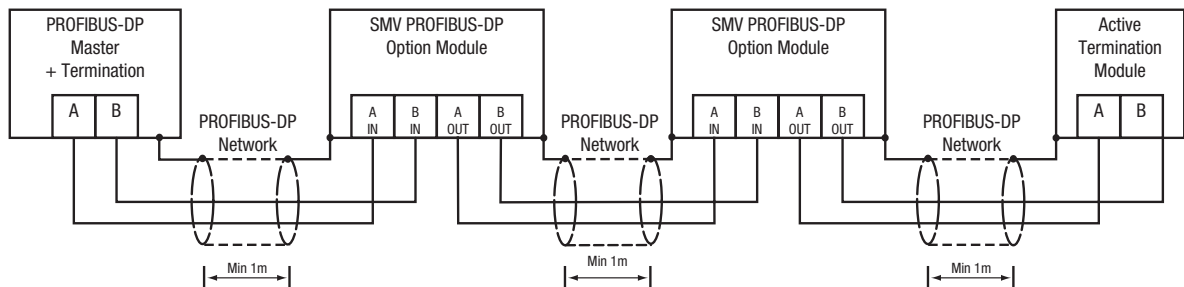

Figure 8b: Network with Active Termination



NOTE

When the SMV PROFIBUS-DP module termination resistor is used, the IN and OUT terminals will be totally isolated and only the IN terminals will have the correct termination. Therefore when using an SMV PROFIBUS-DP module for network termination always ensure the incoming cable is connected to the Ain and Bin terminals.

Commissioning



4 Commissioning

4.1 Overview

It is assumed that the user has familiarised themselves with how to navigate through the drive parameters using the keypad. Refer to the drive user manual for details.

The details that follow provide a step-by-step guide to quickly and easily set-up an SMV drive to communicate on a PROFIBUS-DP fieldbus network, in a basic format. There are many more features and settings available for the PROFIBUS-DP option module, for details on these refer to the fuller description in the sections that follow.



NOTE

Details for configuring a specific network master are not provided herein because the method for configuring master devices can differ greatly between manufacturers. However, a very basic generic guide is provided.

4.2 Configuring the Network Master

4.2.1 Master Support Files

Most PROFIBUS-DP master configuration software utilises GSD files to configure the network profile and communications with the relevant devices. GSD files are text files that contain information about the device timings, features supported and available data formats for the PROFIBUS-DP device. Device icon files are also supplied for use with the PROFIBUS-DP configuration software.



NOTE

Many manufacturers offer language-specific GSD files for their PROFIBUS-DP devices. In this case the term and file suffix “GSD” is used for their primary/default language choice and additional files may be available for alternative languages and will be named differently. For example, for manufacturers where English is not the primary language it may be possible to obtain GSD and GSE files where the GSD file is written in the native/home language and the GSE file will be written in English etc.

The SMV GSD files are available on the CD ROM that ships with the module and on the Lenze-AC Tech website.

4.2.2 PROFIBUS-DP Master Setup Procedure

Details for configuring a specific network master are NOT provided herein. The method for configuring master devices differs greatly between manufacturers. Provided herein is a very basic, generic guide to setting up a network master.

1. Launch the Master configuration software.
2. Install/Import the required GSD support file(s) using the wizard tool if provided.
3. Setup master PROFIBUS-DP port with required criteria such as node address and baudrate etc.
4. Add or “drag and drop” the required slave devices from the GSD library to the PROFIBUS-DP network which is typically depicted on screen.
5. Configure the slave node address, ensuring that each node has a unique and individual address.
6. Configure each slave's I/O data size. (This is typically done by dragging and dropping the required amount of modules from the GSD file library or picking the modules from a list).



Commissioning

NOTE: Although there are only 4 modules listed in the GSD file, these can be used several times to create the required amount of data.

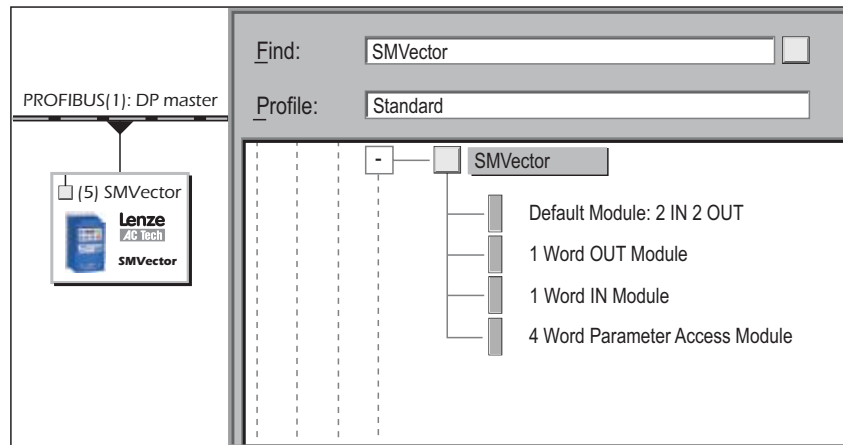

Figure 9: PROFIBUS-DP Master Setup

7. Save the configuration and download to the master.

4.3 Configuring the SMV PROFIBUS-DP Module

4.3.1 Connecting

With the drive power disconnected install the PROFIBUS-DP module and connect the network cable as instructed in the preceding sections. Ensure the drive Run / Enable terminal is disabled then apply the correct voltage to the drive (refer to the drive's user manual for voltage supply details).

4.3.2 Setting the Network Protocol

| P400 - Network Protocol | | | |
|-------------------------|----|--------|---------|
| Default: | 0 | Range: | 0 or 6 |
| Access: | RW | Type: | Integer |

Set P400 = 6 (PROFIBUS-DP)

Some SMV option modules are capable of supporting multiple protocols; therefore it is necessary to set the required protocol. The option module is only initialised after a protocol has been selected.

4.3.3 Node Address

| P410 - Node Address | | | |
|---------------------|-----|--------|---------|
| Default: | 126 | Range: | 0 - 126 |
| Access: | RW | Type: | Integer |

Set P410 to the required value. The default address is 126. The permissible address range is: 0 - 125

Each node on the network must have an individual address, if two or more nodes have duplicate addresses this may prevent the network from functioning correctly. Node 126 is a special node address intended for "New" nodes only where by node configuration is performed via a network master device.

Commissioning



4.3.4 Baud / Data Rate

| P411 - Baud Rate | | | |
|------------------|-----|--------|---------|
| Default: | N/A | Range: | 0 - 10 |
| Access: | RO | Type: | Integer |

P411 = detected value

The SMV PROFIBUS-DP module automatically detects and synchronises to the data rate of the network to which it has been connected. P411 displays a read only value that represents the detected data rate.

Table 4: Data Rates

| P411 Value | Data Rate |
|------------|-----------|
| 0 | Searching |
| 1 | 9.6kbps |
| 2 | 19.1kbps |
| 3 | 45.45kbps |
| 4 | 93.7kbps |
| 5 | 187.5kbps |
| 6 | 500kbps |
| 7 | 1.5Mbps |
| 8 | 3Mbps |
| 9 | 6Mbps |
| 10 | 12Mbps |

4.3.5 Data Mapping

- The SMV PROFIBUS-DP module has support for up to 6 cyclic data channels in both directions.
- Cyclic data configuration is described in full in section 5.
- The default mapping for SMV PROFIBUS-DP is 2 Data IN words and 2 Data OUT words, the configuration is shown in Table 5.

Table 5: Default Mapped Cyclic Data

| Data OUT Channel | Mapped Function | | Data IN Channel | Mapped Function |
|------------------|--------------------|--|-----------------|-------------------------|
| 0 | Drive Control Word | | 0 | Drive Status Word |
| 1 | Frequency Setpoint | | 1 | Actual Output Frequency |



NOTE

The terms "OUT data" and "IN data" describe the direction of data transfer as seen by the PROFIBUS-DP network master controller.



Commissioning

4.3.6 Re-Initialising

| P418 - Re-initialise | | | |
|----------------------|----|--------|---------|
| Default: | 0 | Range: | 0 - 1 |
| Access: | RW | Type: | Integer |

Set P418 = 1 to activate any changes made to the module settings i.e. changing any parameters in the 400 range means the module has to be re-initialised. This can also be done by cycling power to the drive.



NOTE

The module is only re-initialised following a transition from 0 to 1 in P418



WARNING

PROFIBUS-DP re-initialisation may activate the new Dout configuration, which can result in changes to the present controller state, including starting.

4.3.7 Check Node Status

| P419 - Node Status | | | |
|--------------------|-----|--------|---------|
| Default: | N/A | Range: | 0 - 4 |
| Access: | RO | Type: | Integer |

Once initialised and the network detected, the module should enter the “Data Exchange” state (P419=4). Refer to Table 6 for the Node Status description.

Table 6: Module Status

| P419 Value | Node Status | Description |
|------------|--------------------------------|---|
| 0 | Module Offline | No node action |
| 1 | Baud Rate Search | Detecting the baud rate set by the network master |
| 2 | Waiting for Parameterization | Waiting for network master setup |
| 3 | Waiting for Configuration Data | Waiting for network master to establish cyclic message format |
| 4 | Data Exchange | Cyclic data has been established successfully |

4.3.8 Non-Module Parameter Settings

In addition to configuring the PROFIBUS-DP option module there are several drive based parameters that may need to be set. Such as:

- P100 - Start Control Source; network control is possible in any of the modes except mode 2 - “Remote Keypad Only”.
- P112 - Rotation; Used to enable either uni or bi direction rotation of the motor.
- P121, 122 or 123 = 9. One of the digital inputs must be assigned to mode 9 - “Network Control” and have the corresponding input closed to enable write access to the drive parameters.



Cyclic Data Access

5. Cyclic Data Access

5.1 What is Cyclic Data?

- Cyclic / Process / Polled data is the name given to the method used to transfer routine process data between the network master and slave nodes.
- Cyclic data transfer must be configured during network setup.
- The terms “OUT data” and “IN data” describe the direction of data transfer as seen by the PROFIBUS-DP network master controller.
- The cyclic data source and destinations are configured and controlled by the SMV PROFIBUS-DP modules mapping capabilities.

5.2 Mapping Cyclic Data

5.2.1 Data OUT (Dout) Channels

| P440 to P445 - Dout Mapping Channels | | | |
|--------------------------------------|---------|--------|---------|
| Default: | various | Range: | 0 - 9 |
| Access: | RW | Type: | Integer |

- The SMV PROFIBUS-DP module has 6 cyclic OUT channels each of which utilises 1 WORD of data.
- Table 7 lists the mapping destinations for OUT going data being sent from the network master.
- Last mapping channel not equal to 0 sets the size of Dout data portion.

Table 7 – Data OUT (Dout) Mappings

| Parameter | Function | Default | Selection |
|-----------|------------------------|---------|---|
| P440 | Dout Channel 0 mapping | 1 | 0 – Disabled 1 – SMV Control Word |
| P441 | Dout Channel 1 mapping | 2 | 2 – Network Command Frequency 3 – Lenze C135 Control Word |
| P442 | Dout Channel 2 mapping | 0 | 4 – Network Speed in unsigned RPMs 5 – Network PID Setpoint |
| P443 | Dout Channel 3 mapping | 0 | 6 – Network Torque Setpoint 7 – Network Speed in signed RPMs (control direction) |
| P444 | Dout Channel 4 mapping | 0 | 8 – Digital Outputs + Relay |
| P445 | Dout Channel 5 mapping | 0 | 9 – Analog Output |



WARNING

Modification to the Dout configuration may result in changes to present controller state, including starting.

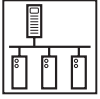

Cyclic Data Access



NOTE

Received Dout data words are processed by the drive in a fixed sequence starting with the Word pointed to by parameter P440 and then P441 ... P445. That might lead to overriding the commands/setpoints mapped earlier in the sequence (ex. in P440) by data mapped later in the sequence (ex. in P445).

Example:

Dout size = 3 words

P440 set to 3 – C135 Lenze Control Word

P441 set to 2 – Network Command Frequency

P442 set to 1 – SMV Control Word

In this case if the C135 Control Word bits are set to STOP and the SMV Control Word bits are set to RUN, the drive will START! (The SMV Control Word pointed to by P442 is processed last)

5.2.2 Data IN (Din) Channels

| P460 to P465 - Din Mapping Channels | | | |
|-------------------------------------|---------|--------|---------|
| Default: | various | Range: | 0 - 550 |
| Access: | RW | Type: | Integer |

- The SMV PROFIBUS-DP module has 6 cyclic IN channels each of which utilises 1 WORD of data.
- In addition to the mappable functions listed in Table 8, any drive parameter can be used as a source parameter. Simply enter the required parameter number into the appropriate mapping parameter.
- Last mapping channel not equal to 0 sets the size of Din data portion

Table 8: Data IN (Din) Mappings

| Parameter | Function | Default | Selection |
|-----------|-----------------------|---------|---|
| P460 | Din Channel 0 mapping | 1 | 0 – Disabled 1 – SMV Status Word 2 – Actual Frequency in 0.1Hz 3 – Lenze C150 Status Word 4 – Actual Speed in RPMs 5 – Auxiliary Status Word 6 – Drive RUN Status 7 – Drive Fault Code 8 - Digital Inputs 9 - Analog 0-10V Input 10 - Analog 4-20mA Input 11 - Actual PID Setpoint 12 - Actual PID Feedback |
| P461 | Din Channel 1 mapping | 2 | |
| P462 | Din Channel 2 mapping | 0 | |
| P463 | Din Channel 3 mapping | 0 | |
| P464 | Din Channel 4 mapping | 0 | |
| P465 | Din Channel 5 mapping | 0 | |



NOTE

Refer to paragraph 5.4 for details on Control and Status Words.

When mapping parameters that have decimal places, scaled integer values are used. For example: to read P508 the Actual Motor Current value, a value of 10.8A would be transmitted as 108.

Cyclic Data Access

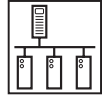

5.3 Channel Data Size

| P415 and P416 - Data Sizes | | | |
|----------------------------|-----|--------|---------------|
| Default: | N/A | Range: | 00.00 - 99.99 |
| Access: | RO | Type: | Integer |

- During network setup, it is necessary to program the network master with the amount of IN and OUT cyclic data used for each slave device that it is associated with. This process is simplified with the use of GSD support files (refer to paragraph 4.2.2, *PROFIBUS-DP Master Setup Procedure*, for details).
- The amount of cyclic data configured in each SMV PROFIBUS-DP module must be equal to the amount configured in the network master. Failure to do this may result in lost data and/or network master configuration errors.
- To aid this routine the SMV PROFIBUS-DP module has two useful parameters that display the amount of IN and OUT cyclic data configured in the master and drive. Refer to Table 9.

Table 9: Directional Data Sizes

| Parameter | Function | Format | Description |
|-----------|--------------------------------|--------|---|
| P415 | Master.Slave Dout Data Size | xx.yy | xx = Master configured number of data WORDs yy = Slave configured number of data WORDs |
| P416 | Master.Slave Din Data Size | xx.yy | |

EXAMPLE

- The master PLC is configured for the slave node to have 4 IN words and 6 OUT words.
- The drive is configured for 2 IN words and 6 OUT words
- When the module is re-initialised (P418) as part of the commissioning routine it will fail to go online. P419 will display the actual status.
- Check P415 and P416 to identify the data size miss-match, i.e.
P415 = 04.02
P416 = 06.06
- To clear the error, the amount of cyclic data used must be rectified and the module re-initialised again.

i **NOTE**
Depending upon the Acyclic data mode selected in P431 it may contribute towards the total cyclic data count too. Refer to P431 for further details. The Acyclic data channels actually utilise cyclic channels. Refer to section 6 for details on Acyclic parameter access

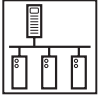

Cyclic Data Access - Dout Mapping

5.4 Cyclic Data

5.4.1 Overview

The control and status words allow the digital control and monitoring of the drive to be implemented using a single data word for each function. Each bit in the control word has a particular function and provides a method of controlling the output functions of the drive, such as run and direction. Each bit in the status word provides feedback about the drive's state of health and operational condition, such as drive healthy, drive at speed, etc. The various Network Setpoints provide a method of editing the drives' Frequency, Speed, Torque or PID control etc.

5.4.2 P44x = 1, SMV Control Word

The SMV Control Word consists of 16 control bits some of which are reserved.

Table 10: SMV Control Word

| b15 | b14 | b13 | b12 | b11 | b10 | b9 | b8 |
|------------|--------------------------|------------------------|--------------------|-----------------------------------|-------------|-------------|-------------|
| DC Braking | PID Disable | Quick Stop | Controller Inhibit | Network Setpoint Reference Source | | | |
| b7 | b6 | b5 | b4 | b3 | b2 | b1 | b0 |
| Reserved | Network Reference Enable | Network Control Enable | Reserved | Reserved | Fault Reset | Run Reverse | Run Forward |

Table 11: SMV Control Word BIT Functions

| BIT | Function | Description |
|-----|-----------------------------------|--|
| 0 | Run Forward | Set to 1 to run the motor in the FORWARD direction. |
| 1 | Run Reverse | Set to 1 to run the motor in the REVERSE direction. |
| 2 | Fault Reset | A 0-to-1 transition will reset the drive from a trip condition. |
| 3 | Reserved | |
| 4 | Reserved | |
| 5 | Network Control Enable | 0 = Local Control 1 = Network Control |
| 6 | Network Reference Enable | 0 = Local Speed Reference 1 = Network Speed Reference |
| 7 | Reserved | |
| 8 | Network Setpoint Reference Source | 0 = Network |
| 9 | | 1 = Keypad |
| 10 | | 2 = 0-10VDC |
| 11 | | 3 = 4-20mA |
| | | 4 = Preset #1 |
| | | 5 = Preset #2 |
| | | 6 = Preset #3 |
| | | 7 = Preset #4 |
| | | 8 = Preset #5 |
| | | 9 = Preset #6 |
| | | 10 = Preset #7 |
| | | 11 = MOP |
| 12 | Controller Inhibit | Set to 1 to disable the drive and allow the motor to coast to a stop |
| 13 | Quick Stop | Set to 1 to disable the drive and stop the ramp time defined in P127 |
| 14 | PID Disable | When using PID mode, setting this bit (14) to 1 will disable PID control. (Active only in Network Control) |
| 15 | DC Braking | Set to 1 to activate DC injection braking. Refer to P174 for details. |



Cyclic Data Access - Dout Mapping

If the SMV Control Word is used, the RUN and STOP commands are controlled as listed in Table 12.

Table 12: SMV Control Word RUN and STOP Events

| BIT 0 - RUN FWD | BIT 1 - RUN REV | Action |
|-----------------|-----------------|-----------------------------------|
| 0 | 0 | STOP Method (Refer to P111) |
| 0 -> 1 | 0 | RUN FORWARD |
| 0 | 0 -> 1 | RUN REVERSE |
| 0 -> 1 | 0 -> 1 | NO ACTION / remains in last state |
| 1 | 1 | NO ACTION / remains in last state |
| 1 -> 0 | 1 | RUN REVERSE |
| 1 | 1 -> 0 | RUN FORWARD |



NOTE

If P112 (ROTATION) is set to FORWARD ONLY, the drive will not be able to run in the reverse direction.

For the purpose of absolute clarity:

"0 -> 1" is the transition from 0 to 1 and "1 -> 0" is the transition from 1 to 0

5.4.3 P44x = 2, Network Frequency Setpoint

The Network Frequency Setpoint is represented as an unsigned Hz value. This mapping along with the use of the correct Control Word Bits allows the drive frequency setpoint to be controlled from the network. This mapping function uses unsigned scaled integer values.

Example:

- Frequency Setpoint value to be transmitted from the network master = 33.5Hz.
- The actual value transmitted to the drive must be 335 (0x014F).

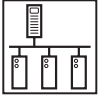

Cyclic Data Access - Dout Mapping

5.4.4 P44x = 3, Lenze C135 Control Word

The Lenze C135 Control Word consists of 16 control bits some of which are reserved.

Table 13: Lenze C135 Control Word

| b15 | b14 | b13 | b12 | b11 | b10 | b9 | b8 |
|--------------------------|------------|----------|----------|-------------|-----------------------|----------------------------|------------------------|
| Network Reference Enable | DC Braking | Reserved | Reserved | Fault Reset | Reserved | Controller Inhibit | Network Control Enable |
| b7 | b6 | b5 | b4 | b3 | b2 | b1 | b0 |
| Reserved | Reserved | Reserved | Reserved | Quick Stop | Direction of Rotation | Network Setpoint Reference | |

Table 14: Lenze C135 Control Word BIT Functions

| BIT | Function | Description |
|-----|-----------------------------------|--|
| 0 | Network Setpoint Reference Source | 0 = Network 1 = Preset #1 2 = Preset #2 3 = Preset #3 (Active only when Network Reference is Enabled) |
| 1 | | |
| 2 | Direction of Rotation | 0 = CW (FORWARD) 1 = CCW (REVERSE) |
| 3 | Quick Stop | Set to 1 to disable the drive and stop the ramp time defined in P127 |
| 4 | Reserved | |
| 5 | Reserved | |
| 6 | Reserved | |
| 7 | Reserved | |
| 8 | Network Control Enable | 0 = Local Control 1 = Network Control |
| 9 | Controller Inhibit | Set to 1 to disable the drive and allow the motor to coast to a stop |
| 10 | Reserved | |
| 11 | Fault Reset | A 0-to-1 transition will reset the drive from a trip condition. If the reason for the trip is still present or another fault condition has been detected, the drive will immediately trip again. When resetting the drive, it is recommended to check the status word to ensure that the reset was successful, before attempting to restart the drive. |
| 12 | Reserved | |
| 13 | Reserved | |
| 14 | DC Braking | Set to 1 to activate DC injection braking. Refer to P174 & 175 for details. |
| 15 | Network Reference Enable | 0 = Local Speed Reference 1 = Network Speed Reference |



Cyclic Data Access - Dout Mapping

5.4.5 P44x = 4 or 7, Network Speed Setpoint

When P44x = 4, the Network Speed Setpoint is represented as an unsigned rpm value.

When P44x = 7, the Network Speed Setpoint is represented as a signed rpm value, Direction Control

Using one of these mappings along with the use of the correct Control Word Bits allows the drive speed setpoint to be controlled from the network.



NOTE

While the values used do not have to be scaled for data transmission, RPM scaling is based on P304 Motor Rated Frequency and P305 Motor Rated Speed.

Example: If P304 = 60Hz; P305 = 1750 RPM,
then request setpoint forward (CW) at 25.0 HZ = $25.0 \times 1750/60 = 729 = 0x02D9$

Example 1:

- P44x = 4
- Speed Setpoint value to be transmitted from the network master = 750rpm.
- The actual value transmitted to the drive must be 750 (0x02EE).

Example 2:

- P44x = 7
- Speed Setpoint value to be transmitted from the network master = +750rpm.
- The actual value transmitted to the drive must be 750 (0x02EE).
- Speed Setpoint value to be transmitted from the network master = -333rpm.
- The actual value transmitted to the drive must be -333 (0xFEB3).
- If Reverse Direction is enabled, the drive will reverse as appropriate.

5.4.6 P44x = 5, Network PID Setpoint

The Network PID Setpoint is represented as a signed PID value in the range from -999 to 31000.

This mapping along with the use of the correct Control Word Bits allows the drive PID setpoint (when in PID mode) to be controlled from the network.

5.4.7 P44x = 6, Network Torque Setpoint

The Network Torque Setpoint is represented as an unsigned percent value in the range from 0 to 400%.

This mapping along with the use of the correct Control Word Bits allows the drive torque setpoint (when in torque mode) to be controlled from the network. The maximum torque value is 400%, however P330 can be used to apply an overriding torque limit.

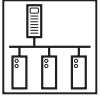

Cyclic Data Access - Dout Mapping

5.4.8 P44x = 8, Network Digital I/O Control Word

To utilise the drive's digital output and relay functions directly from the network master, set:

- P140 = 25 - Relay Network Controlled
- P142 = 25 - Digital Output Network Controlled

The Digital I/O Control Word consists of 16 control bits some of which are reserved.

Table 15: Digital I/O Control Word

| b15 | b14 | b13 | b12 | b11 | b10 | b9 | b8 |
|----------|----------|----------|----------|----------|----------------|-------------------------|----------|
| Reserved | Reserved | Reserved | Reserved | Reserved | Activate Relay | Activate Digital Output | Reserved |
| b7 | b6 | b5 | b4 | b3 | b2 | b1 | b0 |
| Reserved | Reserved | Reserved | Reserved | Reserved | Reserved | Reserved | Reserved |

5.4.9 P44x = 9, Network Analog I/O Control Value

To utilise the drive's analog output directly from the network master set:

- P150 = 9 - Analog Output Network Controlled

This mapping function uses an unsigned scaled integer value.

Example:

- Analog value to be transmitted from the network master = 5.78V.
- The actual value transmitted to the drive must be 578 (0x024B).



Cyclic Data Access - Din Mapping

5.4.10 P46x = 1, SMV Status Word

The SMV Status Word consists of 16 control bits some of which are reserved.

Table 16: SMV Status Word

| b15 | b14 | b13 | b12 | b11 | b10 | b9 | b8 |
|-------------------|----------------------|------------------------|-----------------|----------------------------------|-----------------|----------|---------------|
| DC Braking Status | Current Limit Status | Operating Mode | PID Mode Status | Actual Setpoint Reference Source | | | |
| b7 | b6 | b5 | b4 | b3 | b2 | b1 | b0 |
| At Setpoint Speed | Setpoint Status | Network Control Status | Drive Ready | Running Reverse | Running Forward | Reserved | Drive Faulted |

Table 17: SMV Status Word BIT Functions

| BIT | Function | Description |
|-----|----------------------------------|---|
| 0 | Drive Faulted | 0 = No Fault 1 = Drive Faulted |
| 1 | Reserved | |
| 2 | Running Forward | 1 = Indicates that the drive is running in the FORWARD direction |
| 3 | Running Reverse | 1 = Indicates that the drive is running in the REVERSE direction |
| 4 | Drive Ready | 1 = Drive ready |
| 5 | Network Control Status | 0 = Local Control 1 = Network Control |
| 6 | Setpoint Status | 0 = Local Speed Reference 1 = Network Speed Reference |
| 7 | At Setpoint Speed | 0 = Actual output frequency <> Setpoint value 1 = Actual output frequency = Setpoint value |
| 8 | Actual Setpoint Reference Source | 0 = Keypad |
| 9 | | 1 = 0-10VDC |
| 10 | | 2 = 4-20mA |
| 11 | | 3 = Preset #1 |
| | | 4 = Preset #2 |
| | | 5 = Preset #3 |
| | | 6 = Preset #4 |
| | | 7 = Preset #5 |
| | | 8 = Preset #6 |
| | | 9 = Preset #7 |
| | | 10 = MOP |
| | | 11 = Network |
| 12 | PID Mode Status | 0 = PID off - open loop 1 = PID on - closed loop |
| 13 | Operating Mode | 0 = Drive is in Speed control mode 1 = Drive is in Torque control mode |
| 14 | Current Limit Status | 1 = Current limit reached |
| 15 | DC Braking Status | 0 = DC injection braking is OFF 1 = DC injection braking is active (ON) |

5.4.11 P46x = 2, Actual Frequency

Unsigned actual frequency in Hz with 0.1Hz resolution.

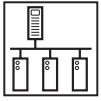

Cyclic Data Access - Din Mapping

5.4.12 P46x = 3, Lenze C150 Status Word

The Lenze C150 Status Word consists of 16 control bits some of which are reserved.

Table 18: Lenze C150 Status Word

| b15 | b14 | b13 | b12 | b11 | b10 | b9 | b8 |
|--------------------|-----------------------|--------------|-------------------|-------------------|----------------------|---------------|----------|
| Drive Healthy | Direction of Rotation | Over Voltage | Over Temp Warning | Controller Status | | | |
| b7 | b6 | b5 | b4 | b3 | b2 | b1 | b0 |
| Controller Inhibit | At Zero Speed | Above Speed | At Setpoint Speed | Reserved | Current Limit Status | Pulse Inhibit | Reserved |

Table 19: Lenze C150 Status Word BIT Functions

| BIT | Function | Description |
|-----|-----------------------|---|
| 0 | Reserved | |
| 1 | Pulse Inhibit | 0 = Pulse outputs enabled 1 = Pulse outputs inhibited |
| 2 | Current Limit Status | 0 = Current limit not reached 1 = Current limit reached |
| 3 | Reserved | |
| 4 | At Setpoint Speed | 0 = Actual output frequency <> Setpoint value 1 = Actual output frequency = Setpoint value |
| 5 | Above Speed | 0 = Actual output frequency <= P136 value 1 = Actual output frequency > P136 value |
| 6 | At Zero Speed | 0 = Actual output frequency <> 0 Hz 1 = Actual output frequency = 0 Hz |
| 7 | Controller Inhibit | 0 = Controller Enabled 1 = Controller Inhibited |
| 8 | Controller Status | 0 = No Fault 8 = Fault Present |
| 9 | | |
| 10 | | |
| 11 | | |
| 12 | Over Temp Warning | 0 = No over-temperature fault 1 = Over-temperature fault |
| 13 | Over Voltage | 0 = No DC bus over-voltage 1 = DC bus over-voltage |
| 14 | Direction of Rotation | 0 = CW (FORWARD) 1 = CCW (REVERSE) |
| 15 | Drive Ready | 0 = Not ready 1 = Ready (No Faults) |

5.4.13 P46x = 4, Actual Speed in RPMs

Unsigned Actual Speed in RPMs. Range: 0 - 65535.



Cyclic Data Access - Din Mapping

5.4.14 P46x = 5, Auxiliary Status

The Auxiliary Status Word consists of 16 control bits some of which are reserved.

Table 20: Auxiliary Status Word

| b15 | b14 | b13 | b12 | b11 | b10 | b9 | b8 |
|-------------------|-----------------|----------------|-----------------|-----------------------------------|---------------|-------------------|------------|
| DC Braking Status | Network Control | Control Mode | | Actual Network Setpoint Reference | | | |
| b7 | b6 | b5 | b4 | b3 | b2 | b1 | b0 |
| Drive Status Mode | PID Mode Status | Operating Mode | Setpoint Status | Actual Direction | Cmd Direction | Quick Stop Status | Run Status |

Table 21: Auxiliary Status Word BIT Functions

| BIT | Function | Description |
|-----|--|---|
| 0 | Run Status | 0 = Drive is Stop mode 1 = Drive is Run mode |
| 1 | Quick Stop Status | 0 = Quick Stop is Not Active 1 = Quick Stop is Active |
| 2 | Cmd Direction | 0 = Commanded direction is FORWARD 1 = Commanded direction is REVERSE |
| 3 | Actual Direction | 0 = Actual direction is FORWARD 1 = Actual direction is REVERSE |
| 4 | Setpoint Status | 0 = Setpoint source is local 1 = Setpoint source control is from network |
| 5 | Operating Mode | 0 = Drive in Speed control mode 1 = Drive in Torque control mode |
| 6 | PID Mode Status | 0 = PID off - open loop 1 = PID on - closed loop |
| 7 | Drive Status Mode | 0 = Manual Mode 1 = Auto Mode |
| 8 | Actual Network Setpoint Reference Source | 0 = Keypad |
| 9 | | 4 = Preset #2 |
| 10 | | 8 = Preset #6 |
| 11 | | 11 = Network |
| | | 1 = 0-10VDC |
| | | 5 = Preset #3 |
| | | 6 = Preset #4 |
| | | 7 = Preset #5 |
| | | 2 = 4-20mA |
| | | 3 = Preset #1 |
| 12 | Control Mode | 0 = Keypad |
| 13 | | 1 = Terminal |
| | | 3 = Network |
| | | 2 = Remote Keypad |
| 14 | Network Control Status | 0 = Disabled 1 = Enabled |
| 15 | DC Braking Status | 0 = DC injection braking is OFF 1 = DC injection braking is active (ON) |

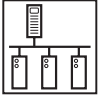

Cyclic Data Access - Din Mapping

5.4.15 P46x = 6, Drive RUN Status

The Drive RUN status indicates the run status the drive is currently in.

Table 22: Drive RUN Status

| RUN Status Value | Description |
|------------------|---|
| 0 | Drive Faulted, attempted restart & locked; Requires manual reset |
| 1 | Drive Faulted; Check P500 Fault History and correct fault condition |
| 2 | Drive has tripped into a fault and will automatically restart |
| 3 | Identification not complete |
| 4 | Forced Coast Stop |
| 5 | Drive is Stopped |
| 6 | Drive is Preparing to Run |
| 7 | Drive is in Identification State |
| 8 | Drive is in Run State |
| 9 | Drive is Accelerating |
| 10 | Drive is Decelerating |
| 11 | Drive stopped decelerating to avoid tripping HF fault, due to excessive motor regen (2 s max) |
| 12 | DC Injection brake activated |
| 13 | Flying Restart Attempt after Fault |
| 14 | Current Limit Reached |
| 15 | Fast Current Limit Overload |
| 16 | Drive is in Sleep Mode |

5.4.16 P46x = 7, Drive Fault Status

The Drive Fault Status indicates the drive's present fault condition.

Table 23: Drive Fault Status

| Fault Codes | | |
|--------------|---------------|---|
| Fault Number | Drive Display | Fault Description |
| 0 | | NO FAULT |
| 1 | F.AF | Temperature Output Fault |
| 2 | F.OF | Over Current Fault |
| 3 | F.OF1 | Ground (Short to Earth) Fault |
| 4 | F.AF | Excess Drive Temperature Fault |
| 5 | F.rF | Fly Start Fault |
| 6 | F.hF | High Bus Voltage (Over Voltage) Fault |
| 7 | F.LF | Low Bus Voltage (Under Voltage) Fault |
| 8 | F.PF | Motor Overload Fault |
| 9 | F.JF | OEM Defaults Corrupted Fault |
| 10 | F.IL | Illegal Setup Fault |
| 11 | F.dbF | Dynamic Brake Overheated Fault |
| 12 | F.SF | Single Phase Voltage Ripple to High Fault |



Cyclic Data Access - Din Mapping

| Fault Codes | | |
|--------------|---------------|---|
| Fault Number | Drive Display | Fault Description |
| 13 | F.EF | External Fault |
| 14 | F.CF | Control EEPROM Fault |
| 15 | F.UF | Start Power Loss Fault |
| 16 | F.cF | Incompatibility Fault |
| 17 | F.F1 | EEPROM Hardware Failure |
| 18 | F.F2 | Edge Over Run; Soft Intr Re-entry |
| 19 | F.F3 | PWM Over Run |
| 20 | F.F5 | Stack Over Voltage Fault |
| 21 | F.F5 | Stack Under Voltage Fault |
| 22 | F.F6 | BGD Missing Fault |
| 23 | F.F7 | Watchdog Timed Out Fault |
| 24 | F.F8 | Illegal OPCO Fault |
| 25 | F.F9 | Illegal Address Fault |
| 26 | F.bF | Drive Hardware Fault |
| 27 | F.F12 | AD Offset Fault |
| 28 | F.JF | RKPD Lost Fault |
| 29 | F.AL | Assertion Level switched during Operation Fault |
| 30 | F.F4 | FGD Missing Fault |
| 31 | F.F0 | PW Missing Fault |
| 32 | F.FOL | Follower Loss |
| 33 | F.F11 | Internal Communication from JK1 Lost Fault |
| 34 | F.ntF | Module Communication (SPI) Timeout Fault |
| 35 | F.fnr | FNR (Invalid Message Received)Fault |
| 36 | F.nF1 | Network Fault #1 |
| 37 | F.nF2 | Network Fault #2 |
| 38 | F.nF3 | Network Fault #3 |
| 39 | F.nF4 | Network Fault #4 |
| 40 | F.nF5 | Network Fault #5 |
| 41 | F.nF6 | Network Fault #6 |
| 42 | F.nF7 | Network Fault #7 |
| 43 | F.nF8 | Network Fault #8 |
| 44 | F.nF9 | Network Fault #9 |
| 46 - 50 | | RESERVED |

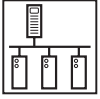

Cyclic Data Access - Din Mapping

5.4.17 P46x = 8, Digital I/O Status

The Digital I/O Status Word consists of 16 control bits some of which are reserved.

Table 24: Digital I/O Status Word

| b15 | b14 | b13 | b12 | b11 | b10 | b9 | b8 |
|--------------------|--------------------|----------|------------|----------|--------------|--------------------|--------------------|
| Reserved | Reserved | Reserved | Reserved | Reserved | Relay Active | TB14 Output Active | TB13C Input Active |
| b7 | b6 | b5 | b4 | b3 | b2 | b1 | b0 |
| TB13B Input Active | TB13A Input Active | Reserved | TB1 Active | Reserved | Reserved | Reserved | Reserved |

5.4.18 P46x = 9, Analog 0-10V Input

Analog Input: 0 - 10V in 0.1 VDC increments

Received Value = 0x3A = 5.8 VDC

5.4.19 P46x = 10, Analog 4-20mA Input

Analog Input: 4 - 20mA in 0.1 mA increments

Received Value = 0xA5 = 16.5 mA

5.4.20 P46x = 11, Actual PID Setpoint

Signed value: -999 to 31000

5.4.21 P46x = 12, Actual PID Feedback

Signed value: -999 to 31000

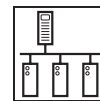

Acyclic Parameter Access

6. Acyclic Parameter Access

6.1 What is Acyclic Data?

- Acyclic / non-cyclic / Service access provides a method for the network master to access any drive or module parameter.
- This kind of parameter access is typically used for monitoring or low priority non-scheduled parameter access.
- The SMV PROFIBUS-DP module supports several different methods of doing this.

6.2 Setting the Acyclic Mode

6.2.1 Acyclic Modes

| P431 - Acyclic Parameter Access Mode | | | |
|--------------------------------------|----|--------|---------|
| Default: | 0 | Range: | 0 - 2 |
| Access: | RW | Type: | Integer |

P431 is used to select the required Acyclic mode as shown in Table 25. Refer to section 6.3 for details on type of acyclic mode. The acronym "4WPA" indicates "4 Words Parameter Access".

Table 25: Acyclic Modes

| P431 Value | Acyclic Mode | Description |
|------------|--------------|----------------------------------|
| 0 | Disabled | No acyclic parameter access |
| 1 | 4WPA-F | 4 word parameter access at front |
| 2 | 4WPA-E | 4 word parameter access at end |

6.2.2 Acyclic Mode 1

P431 = 1 (Mode 1 - 4WPA-F)

Setting this mode configures the PROFIBUS-DP module to expect 4 additional cyclic words at the FRONT of all normal process cyclic data.

6.2.3 Acyclic Mode 2

P431 = 2 (Mode 2 - 4WPA-E)

Setting this mode configures the PROFIBUS-DP module to expect 4 additional cyclic words at the END of all normal process cyclic data.



NOTE

Enabling a 4WPA mode adds to the total amount of IN and OUT cyclic data and is reflected in the Channel Data Size parameters P415 and P416. Care should also be taken in selecting the correct module from the GSD file when configuring the network master. Changes made to P431 will only take effect after re-initialising the module.

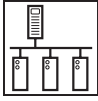

Acyclic Parameter Access

6.3 Modes 1 & 2 - 4WPA Format

The 4WPA format of acyclic parameter data access is a simple method that utilises 4 words of cyclic data which can be placed either before the regular cyclic data or after depending on the users preference or application requirements. 4WPA is comprised of 4 words of data.

Table 26: 4WPA Format

| Word | Byte | Function | |
|------|------|-------------------------|--------------|
| 0 | 0 | Function Code | |
| | 1 | Access Control & Status | |
| 1 | 2 | Parameter Number | Byte 2 = MSB |
| | 3 | | Byte 3 = LSB |
| 2 | 4 | Sub-Index | |
| | 5 | Data Word | Byte 5 = MSB |
| 3 | 6 | | Byte 6 = LSB |
| | | 7 | Reserved |

6.3.1 4WPA - Function Code (Byte 0)

The purpose of the Function Code is to provide control and status information of the acyclic data.

Table 27: 4WPA Function Code

| Bit | Description |
|-----|--|
| 0 | Note: 0, 3 & 6 are Decimal Values 0 = Idle Message 3 = Read Parameter 6 = Write Parameter |
| 1 | |
| 2 | |
| 3 | |
| 4 | |
| 5 | |
| 6 | |
| 7 | 0 = No Fault 1 = Fault, Access Failure, See Access Control |

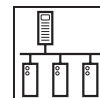

Acyclic Parameter Access

6.3.2 4WPA - Access Control and Status (Byte 1)

The purpose of the Access Control and Status Byte is to provide transfer control and diagnostic information when an acyclic message fails. The Status bits provide diagnostics on the message currently being processed.

Table 28: 4WPA Access Control and Status

| Bit | Description |
|-----|---|
| 0 | 0 = No fault, Write ACK 8 = Invalid value |
| 1 | 1 = Invalid function 9 = Access failure |
| 2 | 2 = Parameter does not exist 10 = Write operation failure |
| 3 | 3 = Invalid subindex 11 = Reserved |
| | 4 = Read only parameter 12 = Reserved |
| | 5 = Network write disabled 13 = Reserved |
| | 6 = Value too high 14 = Reserved |
| | 7 = Value too low 15 = ACT unknown exception |
| 4 | 1 = Valid response to the request message - bit set by module to indicate the data in message is valid or acknowledgment for write access (it could be negative if bit 7 of Byte 0 is set and the exception number is higher than 0). |
| 5 | 1 = Module is processing the master's request. Any data being sent to the master at this time is invalid. |
| 6 | Reserved |
| 7 | Toggle bit. (Handshake) Master toggles this bit to indicate a new message. The old command (if not finished) is cancelled. |



NOTE

Bits 0 to 6 are set by the module. Bit 7 is set by the master. The module matches the state of bit 7 in its response message.



NOTE

1. Bit 7 of the Access & Status byte will cause the message to be executed when it changes state. Each time this bit changes state it indicates a new request is being made. This bit must be set by the Master/PLC once all other bytes have been set in the 4WPA message. Otherwise a partially assembled message will be processed by the drive causing unexpected results.
2. The drive will copy the state of Bit 7 from the message sent by the master to Bit 7 in the response.
3. Bit 7 is set indicating a fault occurred. Fault information is contained in the Access Control & Status Byte
4. This drive had an external fault in the Fault 3 location (Fault History Example 3).

6.3.3 4WPA - Parameter Number (Bytes 2 & 3)

This is the drive parameter number to be Read or Written to from the master. For the reply message from the drive this will contain the drive parameter number that message corresponds to. Byte 2 is the Most Significant Byte (MSB) of the 16 Bit Parameter Number. Byte 3 is the Least Significant Byte (LSB).



Acyclic Parameter Access

6.3.4 4WPA - Sub-Index (Byte 4)

During normal drive parameter access the data size is always 16-Bit, however, there are several drive parameters that are 32-Bit in size. Therefore setting the sub-index determines which word of the parameter is transmitted in the Data Word. Table 29 lists the drive parameters this applies to.

Table 29: 4WPA Sub-Index

| Parameter | Function | Sub-Index |
|-----------|---------------------|--|
| P500 | Fault History | 0 = Fault 1 and 2 1 = Fault 3 and 4 2 = Fault 5 and 6 3 = Fault 7 and 8 |
| P511 | kWh | 0 = Lower Word 1 = Upper Word |
| P540 | Total Run Time | 0 = Lower Word 1 = Upper Word |
| P541 | Total Power-On Time | 0 = Lower Word 1 = Upper Word |

6.3.5 4WPA - Data Word (Bytes 5 & 6)

During a Write, this contains the data to be written from the master. During a reply message from the drive this will contain the drive parameter data. Byte 5 is the Upper Byte of the 16 Bit Data Word. Byte 6 is the Lower Byte of the 16 Bit Data Word.

6.3.6 4WPA - Reserved (Byte 7)

Reserved.

6.4 Acyclic Parameter Access Examples

Only the acyclic parameter information is configured for the these examples.

Example 1: Read Accel1, parameter 104 (= 20.0, default value)

Valid Transmission:

SEND: message consisting of:

| Byte 0 | Byte 1 | Byte 2 | Byte 3 | Byte 4 | Byte 5 | Byte 6 | Byte 7 |
|--------|--------------------------------|---------------|--------|-----------|--------|--------|----------|
| 0x03 | 0x08 or 0x00 (Note 1) | 0x00 | 0x68 | 0x00 | 0x00 | 0x00 | 0x00 |
| Read | Toggle | Parameter 104 | | Sub Index | Data | | Reserved |

RECEIVE: response consisting of:

| Byte 0 | Byte 1 | Byte 2 | Byte 3 | Byte 4 | Byte 5 | Byte 6 | Byte 7 |
|--------|--------------------------------|---------------|--------|-----------|----------|--------|----------|
| 0x03 | 0x10 or 0x90 (Note 2) | 0x00 | 0x68 | 0x00 | 0x00 | 0xC8 | 0x00 |
| Read | Valid Response | Parameter 104 | | Sub-Index | Data 200 | | Reserved |



Acyclic Parameter Access

Invalid Transmission:

SEND: message consisting of non-existent parameter:

| Byte 0 | Byte 1 | Byte 2 | Byte 3 | Byte 4 | Byte 5 | Byte 6 | Byte 7 |
|--------|--------------------------------|-------------|--------|-----------|--------|--------|----------|
| 0x03 | 0x80 or 0x00 (Note 1) | 0x00 | 0xA4 | 0x00 | 0x00 | 0x00 | 0x00 |
| REad | Toggle | Address 164 | | Sub Index | Data | | Reserved |

RECEIVE: response consisting of response message and status:

| Byte 0 | Byte 1 | Byte 2 | Byte 3 | Byte 4 | Byte 5 | Byte 6 | Byte 7 |
|------------------|--|---------------|--------|-----------|--------|--------|----------|
| 0x83 (Note 3) | 0x12 or 0x92 (Note 2) | 0x00 | 0xA4 | 0x00 | 0x00 | 0x00 | 0x00 |
| Read | Valid Response, Parameter does not exist | Parameter 164 | | Sub-Index | Data | | Reserved |

Example 2: Write Accel1, parameter 104

Valid Transmission:

SEND: message consisting of:

| Byte 0 | Byte 1 | Byte 2 | Byte 3 | Byte 4 | Byte 5 | Byte 6 | Byte 7 |
|--------|--------------------------------|---------------|--------|-----------|----------|--------|----------|
| 0x06 | 0x80 or 0x00 (Note 1) | 0x00 | 0x68 | 0x00 | 0x01 | 0xC2 | 0x00 |
| Write | Toggle | Parameter 104 | | Sub Index | Data 450 | | Reserved |

RECEIVE: response consisting of:

| Byte 0 | Byte 1 | Byte 2 | Byte 3 | Byte 4 | Byte 5 | Byte 6 | Byte 7 |
|--------|--------------------------------|---------------|--------|-----------|----------|--------|----------|
| 0x06 | 0x10 or 0x90 (Note 2) | 0x00 | 0x68 | 0x00 | 0x01 | 0xC2 | 0x00 |
| Write | Valid Response | Parameter 104 | | Sub Index | Data 450 | | Reserved |

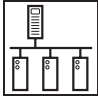

Acyclic Parameter Access

Invalid Transmission:

SEND: message trying to write to a read-only parameter:

| Byte 0 | Byte 1 | Byte 2 | Byte 3 | Byte 4 | Byte 5 | Byte 6 | Byte 7 |
|--------|--------------------------------|---------------|--------|-----------|---------|--------|----------|
| 0x06 | 0x80 or 0x00 (Note 1) | 0x01 | 0xF6 | 0x00 | 0x00 | 0x15 | 0x00 |
| Write | Toggle | Parameter 502 | | Sub Index | Data 21 | | Reserved |

RECEIVE: response consisting of:

| Byte 0 | Byte 1 | Byte 2 | Byte 3 | Byte 4 | Byte 5 | Byte 6 | Byte 7 |
|------------------|--|---------------|--------|-----------|---------|--------|----------|
| 0x86 (Note 3) | 0x14 or 0x94 (Note 2) | 0x01 | 0xF6 | 0x00 | 0x00 | 0x15 | 0x00 |
| Read | Valid Response, Read-only parameter | Parameter 502 | | Sub Index | Data 21 | | Reserved |

Example 3: Read Fault History, Fault 5 and 6, use sub-index byte to access 32-bit parameter

SEND: message consisting of:

| Byte 0 | Byte 1 | Byte 2 | Byte 3 | Byte 4 | Byte 5 | Byte 6 | Byte 7 |
|--------|--------------------------------|---------------|--------|-----------|--------|--------|----------|
| 0x03 | 0x80 or 0x00 (Note 1) | 0x01 | 0xF4 | 0x01 | 0x00 | 0x00 | 0x00 |
| Read | Toggle | Parameter 500 | | Sub Index | Data | | Reserved |

RECEIVE: response consisting of:

| Byte 0 | Byte 1 | Byte 2 | Byte 3 | Byte 4 | Byte 5 | Byte 6 | Byte 7 |
|--------|--------------------------------|---------------|--------|-----------|--|--------|----------|
| 0x03 | 0x10 or 0x90 (Note 2) | 0x01 | 0xF4 | 0x01 | 0x0D (Note 4) | 0x00 | 0x00 |
| Read | Valid Response | Parameter 500 | | Sub Index | Data 3: External Fault; 4: No Fault | | Reserved |



NOTE

1. Bit 7 of the Access & Status byte will cause the message to be executed when it changes state. Each time this bit changes state it indicates a new request is being made. This bit must be set by the Master/PLC once all other bytes have been set in the 4WPA message. Otherwise a partially assembled message will be processed by the drive causing unexpected results.
2. The drive will copy the state of Bit 7 from the message sent by the master to Bit 7 in the response.
3. Bit 7 is set indicating a fault occurred. Fault information is contained in the Access Control & Status Byte
4. This drive had an external fault in the Fault 3 location (Fault History Example 3).



Advanced Features

7 Advanced Features

7.1 Option Module Advanced Parameters

7.1.1 Module Revision

| P401 - Module Revision | | | |
|------------------------|-------|--------|---------------|
| Default: | 6.x.x | Range: | 6.0.0 - 6.9.9 |
| Access: | RO | Type: | Integer |

Display reads 6.x.x where: 6 = PROFIBUS-DP Module and x.x = Module Revision

7.1.2 Module Status

| P402 - Module Status | | | |
|----------------------|-----|--------|---------|
| Default: | N/A | Range: | 0 - 7 |
| Access: | RO | Type: | Integer |

Table 30: Module Status

| P402 Value | Description |
|------------|---------------------------------|
| 0 | Not Initialised |
| 1 | Initialisation: Module to EPM |
| 2 | Initialisation: EPM to Module |
| 3 | Online |
| 4 | Error: Failed Initialisation |
| 5 | Error: Time Out |
| 6 | Error: Module Mismatch (P401) |
| 7 | Error: Protocol Mismatch (P400) |

7.1.3 Restore Defaults

| P403 - Restore Defaults | | | |
|-------------------------|-----|--------|---------|
| Default: | N/A | Range: | 0 - 1 |
| Access: | RW | Type: | Integer |

Table 31: Restore Defaults

| P403 Value | Description |
|------------|---|
| 0 | No Action |
| 1 | Reset Module Parameters to Factory Defaults |



Advanced Features

7.1.4 Module Time-out Action

| P404 - Module Time-out Action | | | |
|-------------------------------|----|--------|---------|
| Default: | 3 | Range: | 0 - 3 |
| Access: | RW | Type: | Integer |

This parameter controls the action to be taken in the event of a Module-to-Drive time out. The Time-out period is fixed at 200 ms.

Table 32: Module Time-out Action

| P404 Value | Description |
|------------|---------------------------|
| 0 | No Action |
| 1 | Stop (controlled by P111) |
| 2 | Quick Stop |
| 3 | Fault $F_{.n\&F}$ |

7.1.5 Module Firmware

| P494 - Module Firmware | | | |
|------------------------|-----|--------|--------------|
| Default: | N/A | Range: | 1.00 - 99.99 |
| Access: | RO | Type: | Integer |

Displays the module firmware revision in the format of xx.yy, where: xx = Major version and yy = Minor version

7.1.6 Module Internal Code

| P495 - Module Internal Code | | | |
|-----------------------------|--------|--------|---------|
| Default: | 209-yy | Range: | |
| Access: | RO | Type: | Integer |

Displays the internal code revision in the format of xxx-yy. The display alternates between xxx- and -yy.

7.1.7 Missed Messages

| P498 and P499 - Missed Messages | | | |
|---------------------------------|-----|--------|---------|
| Default: | N/A | Range: | |
| Access: | RO | Type: | Integer |

Table 33: Missed Messages

| Parameter | Function | Description |
|-----------|---------------------------------|---|
| P498 | Missed Messages Drive to Module | Displays the quantity of missed data messages being transmitted from the drive to the option module |
| P499 | Missed Messages Module to Drive | Displays the quantity of missed data messages being transmitted from the option module to the drive |



Advanced Features

7.2 Network Fault

| P405 - Network Fault | | | |
|----------------------|-----|--------|---------|
| Default: | N/A | Range: | 0 - 2 |
| Access: | RO | Type: | Integer |

This parameter displays the cause of the network fault.

Table 34: Network Fault

| P405 Value | Description |
|------------|--------------------------------------|
| 0 | No Fault |
| 1 | $F_{,nF1}$ - Master Monitor Time-out |
| 2 | $F_{,nF2}$ - Data Exchange Time-out |

7.3 Master Monitor

7.3.1 Master Monitoring Time-out

| P423 - Master Monitoring Time-out | | | |
|-----------------------------------|-----|--------|----------------|
| Default: | N/A | Range: | 0 - 655.35 sec |
| Access: | RO | Type: | Integer |

This parameter displays the Monitoring / Watchdog Time (in seconds) set by the network master during the parameterization phase.

7.3.2 Master Monitoring Time-out Action

| P424 - Master Monitoring Time-out Action | | | |
|--|----|--------|---------|
| Default: | 4 | Range: | 0 - 4 |
| Access: | RW | Type: | Integer |

This parameter controls the action to be taken in the event of a Master Monitoring Time-out.

Table 35: Master Monitoring Time-out Action

| P424 Value | Description | Time-out Action |
|------------|---------------------------|--|
| 0 | No Action | Only Active in Network Control (n.xxx) |
| 1 | Stop (controlled by P111) | |
| 2 | Quick Stop | |
| 3 | Inhibit (Coast to Stop) | |
| 4 | Fault $F_{,nF1}$ | |



Advanced Features

7.4 Data Exchange

7.4.1 Data Exchange Time-out

| P425 - Data Exchange Time-out | | | |
|-------------------------------|----------|--------|-----------|
| Default: | 200 msec | Range: | 0 - 65535 |
| Access: | RW | Type: | Integer |

Data Exchange Time-out provides an independent method for the module to ensure that communication with the master is still present. This parameter sets the time out limit so if no data is received for the time period set, the module will react as per the setting of P426.

7.4.2 Data Exchange Time-out Action

| P426 - Data Exchange Time-out Action | | | |
|--------------------------------------|----|--------|---------|
| Default: | 4 | Range: | 0 - 4 |
| Access: | RW | Type: | Integer |

This parameter controls the action to be taken in the event of a Data Exchange Time-out.

Table 36: Data Exchange Time-out Action

| P426 Value | Description | Time-out Action |
|------------|---------------------------|--|
| 0 | No Action | Only Active in Network Control (n.xxx) |
| 1 | Stop (controlled by P111) | |
| 2 | Quick Stop | |
| 3 | Inhibit (Coast to Stop) | |
| 4 | Fault F ₀ FF2 | |

7.4.3 Data Exchange Frequency

| P428 - Data Exchange Frequency | | | |
|--------------------------------|-----|--------|---------|
| Default: | N/A | Range: | 0 - 999 |
| Access: | RO | Type: | Integer |

This parameter displays the number of cyclic messages received (Dout) per second.

7.4.4 Data Exchange Counter

| P429 - Data Exchange Counter | | | |
|------------------------------|-----|--------|---------|
| Default: | N/A | Range: | 0 - 255 |
| Access: | RO | Type: | Integer |

This parameter counts the number of cyclic messages received (Dout). After reaching the maximum of 255 the counter will automatically reset to 0.



Advanced Features

7.5 Node Address Lock

| P413 - Node Address Lock | | | |
|--------------------------|----|--------|---------|
| Default: | 0 | Range: | 0 - 1 |
| Access: | RW | Type: | Integer |

Some PROFIBUS-DP masters have the capability to set the node address remotely. While this can be a useful feature during commissioning and or network fault recovery, it is not always desirable. Enabling the Node Address Lock will prevent the accidental changing of the node address by preventing the master from writing to it.

Table 37: Node Address Lock

| P413 Value | Description |
|------------|--------------------------|
| 0 | Disabled |
| 1 | Enabled (address locked) |



NOTE

Node Address Lock does not effect accessing the Node Address Parameter (P410) via drive keypad access.

7.6 Sync and Freeze

7.6.1 Sync and Freeze Overview

The network master can put cyclic data into groups which allows multiple cyclic channels to be suspended and updated using the SYNC and FREEZE commands.

The SYNC Command:

- Controls data to the drive. (Dout)
- The SYNC command will cause a single transfer of the previously grouped data and stop any more data from being received by the drive.
- The SYNC command may be repeated while in this state to allow another single transfer of data to the drive.
- Issuing an UNSYNC command will revert the drive to a continuous cyclic update of the received data.

The FREEZE Command:

- Controls data from the drive. (Din)
- The FREEZE command will cause a single update of the previously grouped Din data. In the next data cycle, the drive transfers "frozen" data to the master.
- The Din data will not be updated until the next FREEZE command is received (next "snapshot" taken) or the FREEZE mode is cancelled by an UNFREEZE command.
- Issuing an UNFREEZE command will revert the drive to a continuous cyclic update of the transmitted data.



Advanced Features

7.6.2 Sync and Freeze Status

| P421 - Sync and Freeze Status | | | |
|-------------------------------|-----|--------|-------|
| Default: | N/A | Range: | 0 - 7 |
| Access: | RO | Type: | Bit |

Table 38: Sync and Freeze Status

| P421 Value | Description |
|------------|----------------|
| Bit 0 | Reserved |
| Bit 1 | Clear Out Data |
| Bit 2 | Unfreeze |
| Bit 3 | Freeze |
| Bit 4 | Unsync |
| Bit 5 | Sync |
| Bit 6 | Reserved |
| Bit 7 | Reserved |

7.7 Data Sizes

7.7.1 Dout Data Size

| P449 - Dout Data Size (in Bytes) | | | |
|----------------------------------|-----|--------|---------|
| Default: | N/A | Range: | 0 - 20 |
| Access: | RO | Type: | Integer |

This parameter displays in bytes the total amount of Dout data including outward going 4WPA data.

7.7.2 Din Data Size

| P469 - Din Data Size (in Bytes) | | | |
|---------------------------------|-----|--------|---------|
| Default: | N/A | Range: | 0 - 20 |
| Access: | RO | Type: | Integer |

This parameter displays in bytes the total amount of Din data including incoming 4WPA data.

7.8 Debug Data Viewer

The Debug Data Viewer parameters enable the viewing of raw data being passed between the network master and the option module.

7.8.1 Dout Data Monitor Select

| P450 - Dout Data Monitor Select | | | |
|---------------------------------|-----|--------|---------|
| Default: | 0 | Range: | 0 - 255 |
| Access: | R/W | Type: | Integer |

This parameter selects which Dout word (including 4WPA) of data will be monitored.



Advanced Features

7.8.2 Dout Data Monitor Value

| P451 - Dout Data Monitor Value | | | |
|--------------------------------|----|--------|-----------|
| Default: | 0 | Range: | 0 - 65535 |
| Access: | RO | Type: | Integer |

This parameter displays the actual data value of the Dout word.

7.8.3 Din Data Monitor Select

| P470 - Din Data Monitor Select | | | |
|--------------------------------|----|--------|---------|
| Default: | 0 | Range: | 0 - 255 |
| Access: | RW | Type: | Integer |

This parameter selects which Din word (including 4WPA) of data will be monitored.

7.8.4 Din Data Monitor Value

| P471 - Din Data Monitor Value | | | |
|-------------------------------|----|--------|-----------|
| Default: | 0 | Range: | 0 - 65535 |
| Access: | RO | Type: | Integer |

This parameter displays the actual data value of the Din word.



Diagnositics

8 Diagnostics

8.1 Faults

In addition to the normal drive fault codes, the additional codes listed in Table 39 may be generated by the option module during a fault condition.

Table 39: Fault Codes

| Fault Code | Definition | Remedy |
|------------|----------------------------|--|
| F.nF | Module Time-out | Module to drive communications time out. Check cable and connection between drive and option module. |
| F.nF1 | Master Monitoring Time-out | Check network connection, cabling and termination. Refer to section 7.3 <i>Master Monitor</i> for details |
| F.nF2 | Data Exchange Time-out | Check network connection, cabling and termination. Refer to section 7.4 <i>Data Exchange</i> for details |

8.2 Troubleshooting

Table 40: Troubleshooting

| Symptom | Possible Cause | Remedy |
|---|--|--|
| No communications from the option module | Module is not initialised | <ul style="list-style-type: none"> Check the drive to module connection. Check P400 and P402. |
| | Incorrect PROFIBUS-DP settings | <ul style="list-style-type: none"> Check P410 and P411. If unsure of setting, reset PROFIBUS-DP parameters to factory default using P403. |
| | Improper wiring | <ul style="list-style-type: none"> Check wiring between the PROFIBUS-DP network and communication module. Ensure that the terminal block is properly seated. Check connection between module and drive. |
| PROFIBUS-DP write commands are ignore or return exceptions | "Network enabled" terminal is either open or not configured | Configure one of the input terminals (P121, P122 or P123) to "Network Enabled" function (selection 9) and close the corresponding contact. |
| Drive stops for no obvious reason | One of the PROFIBUS-DP monitoring messages timed out and its time-out reaction is set to STOP. | Identify the time-out message (P423...P429) and modify appropriate time-out time or reaction to the time-out settings. |
| Module does not enter the Data Exchange State. P419 displays 2 or 3 | Data size configuration mismatch between the Master and the Drive | Check the configuration sizes for Dout and Din Data. Refer to Parameters P415 and P416. |
| Drive does not change direction to REVERSE | Parameter P112 is set to 0 (Forward Only) | Set drive parameter P112 to 1 to enable Forward & Reverse direction |



Parameter Reference

9. Parameter Quick Reference

Table 41 lists each parameter number and provides its function, default value and access rights.

Table 41: Parameter Quick Reference

| Parameter | Function | Default Value | Access Rights | Cross Reference |
|-----------|--|---------------|---------------|--|
| P400 | Network Protocol | 0 | RW | 4.3: <i>Configuring the SMV PROFIBUS-DP Module</i> |
| P401 | Module Revision | 6.x.x | RO | 7.1: <i>Option Module Advanced Parameters</i> |
| P402 | Module Status | - | RO | |
| P403 | Restore Defaults | 0 | RW | |
| P404 | Module Time-out Action | 3 | RW | |
| P405 | Network Fault | - | RO | 7.2: <i>Network Fault</i> |
| P406 | Reserved | | RO | |
| P410 | Node Address | 126 | RW | 4.3.3: <i>Node Address</i> |
| P411 | Network Baud Rate | - | RO | 4.3.4: <i>Baud /Data Rate</i> |
| P413 | Node Address Lock | - | RW | 7.5: <i>Node Address Lock</i> |
| P415 | Dout Data Size | - | RO | 5.3: <i>Channel Data Size</i> |
| P416 | Din Data Size | - | RO | |
| P418 | Re-Initialise | - | RW | 4.3.6: <i>Re-initialising</i> |
| P419 | Node Status | - | RO | 4.3.7: <i>Check Node Status</i> |
| P420 | Reserved | - | RO | Factory Reference |
| P421 | Sync and Freeze Status | - | RO | 7.6: <i>Sync and Freeze</i> |
| P423 | Master Monitoring Time-out | - | RO | 7.3: <i>Master Monitor</i> |
| P424 | Master Monitoring Time-out Action | 4 | RW | |
| P425 | Data Exchange Monitoring Time out | - | RO | 7.4: <i>Data Exchange</i> |
| P426 | Data Exchange Monitoring Time out Action | 4 | RW | |
| P428 | Data Exchange Frequency | - | RO | |
| P429 | Data Exchange Counter | - | RO | |
| P430 | Reserved | - | | |
| P431 | Acyclic Parameter Access Mode | 0 | RW | 6.2.1: <i>Acyclic Modes</i> |
| P440 | Dout Channel 0 mapping | 1 | RW | 5.2.1: <i>Data OUT Channels</i> |
| P441 | Dout Channel 1 mapping | 2 | RW | |
| P442 | Dout Channel 2 mapping | 0 | RW | |
| P443 | Dout Channel 3 mapping | 0 | RW | |
| P444 | Dout Channel 4 mapping | 0 | RW | |
| P445 | Dout Channel 5 mapping | 0 | RW | |
| P449 | Total Dout Data Size (in Bytes) | - | RO | 7.7: <i>Data Sizes</i> |
| P450 | Dout Data Monitor Select | 0 | RW | 7.8: <i>Debug Data Viewer</i> |
| P451 | Dout Data Monitor Value | 0 | RO | |



Parameter Reference

| Parameter | Function | Default Value | Access Rights | Cross Reference |
|-----------|----------------------------------|---------------|---------------|------------------------------------|
| P460 | Din Channel 0 mapping | 1 | RW | <i>5.2.2: Data IN Channels</i> |
| P461 | Din Channel 1 mapping | 2 | RW | |
| P462 | Din Channel 2 mapping | 0 | RW | |
| P463 | Din Channel 3 mapping | 0 | RW | |
| P464 | Din Channel 4 mapping | 0 | RW | |
| P465 | Din Channel 5 mapping | 0 | RW | |
| P469 | Total Din Data Size (in Bytes) | 0 | RO | <i>7.7: Data Sizes</i> |
| P470 | Din Data Monitor Select | 0 | RW | <i>7.8: Debug Data Viewer</i> |
| P471 | Din Data Monitor Value | 0 | RO | |
| P494 | Module Firmware Version | x.xx | RO | <i>7.1.5: Module Firmware</i> |
| P495 | Module Internal Code | 209-yy | RO | <i>7.1.6: Module Internal Code</i> |
| P498 | Missed Messages: Drive to Module | | RO | <i>7.1.7: Missed Messages</i> |
| P499 | Missed Messages: Module to Drive | | RO | |

AC Technology Corporation

630 Douglas Street, Uxbridge MA 01569
Sales: 800-217-9100 * Service: 508-278-9100
www.actech.com

CMVPFB01A