

SMVector - Frequency Inverter **Operating Instructions**

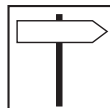

1	Safety Information.....	3
2	Technical Data.....	6
	2.1 Standards and Application Conditions.....	6
	2.2 Ratings.....	6
	2.2.1 NEMA 1 (IP 31) Ratings.....	6
	2.2.2 NEMA 4X (IP65) Ratings.....	8
	2.3 SMV Type Number Designation.....	9
3	Installation.....	10
	3.1 Dimensions and Mounting.....	10
	3.1.1 NEMA 1 (IP31).....	10
	3.1.2 NEMA 4X (IP65).....	11
	3.2 Electrical Installation.....	12
	3.2.1 Power Connections.....	12
	3.2.2 Fuses/Cable Cross-Sections.....	15
	3.2.3 Control Terminals.....	16
4	Commissioning.....	17
	4.1 Local Keypad & Display.....	17
	4.2 Drive Displays and Modes of Operation.....	18
	4.3 Parameter Setting.....	18
	4.4 Electronic Programming Module (EPM).....	18
	4.5 Parameter Menu.....	19
	4.5.1 Basic Setup Parameters.....	19
	4.5.2 I/O Setup Parameters.....	22
	4.5.3 Advanced Setup Parameters.....	26
	4.5.4 PID Parameters.....	29
	4.5.5 Vector Parameters.....	31
	4.5.6 Network Parameters.....	32
	4.5.7 Diagnostic Parameters.....	33
5	Troubleshooting and Diagnostics.....	35
	5.1 Status/Warning Messages.....	35
	5.2 Drive Configuration Messages.....	36
	5.3 Fault Messages.....	37

Copyright © 2006 AC Technology Corporation

All rights reserved. No part of this manual may be reproduced or transmitted in any form without written permission from AC Technology Corporation. The information and technical data in this manual are subject to change without notice. AC Technology Corporation makes no warranty of any kind with respect to this material, including, but not limited to, the implied warranties of its merchantability and fitness for a given purpose. AC Technology Corporation assumes no responsibility for any errors that may appear in this manual.

All information given in this documentation has been carefully selected and tested for compliance with the hardware and software described. Nevertheless, discrepancies cannot be ruled out. AC Technology does not accept any responsibility nor liability for damages that may occur. Any necessary corrections will be implemented in subsequent editions. This document is printed in the United States



About These Instructions

This documentation applies to the SMV frequency inverter and contains important technical data regarding the installation, operation, and commissioning of the inverter.

These instructions are only valid for SMV frequency inverters with software revision 20 (see drive nameplate).

Please read the instructions before commissioning.

A	B	C	D	E	F
 Made in USA Inverter <i>SMV</i> ector	Type: ESV751N04TXB Id-No: 00000000	INPUT: 3 (3/PE) 400/480 V 2.9/2.5 A 50-60 HZ	OUTPUT: 3 (3/PE) 0 - 400/460 V 2.4/2.1 A 0.75 KW/1HP 0 - 500 HZ	For detailed information refer to instruction Manual: SV01 000000000000000000 ESV751N04TXB000XX###	
	LISTED C	 IND. CONT. EQ.			

A	B	C	D	E	F
Certifications	Type	Input Ratings	Output Ratings	Hardware Version	Software Version

Scope of delivery	Important
<ul style="list-style-type: none"> 1 SMV Inverter with EPM installed (see Section 4.4) 1 Operating Instructions 	After receipt of the delivery, check immediately whether the items delivered match the accompanying papers. Lenze-AC Tech does not accept any liability for deficiencies claimed subsequently. Claim: <ul style="list-style-type: none"> visible transport damage immediately to the forwarder. visible deficiencies /incompleteness immediately to your Lenze-AC Tech representative



1 Safety Information

General

Some parts of Lenze-AC Tech controllers can be electrically live and some surfaces can be hot. Non-authorized removal of the required cover, inappropriate use, and incorrect installation or operation creates the risk of severe injury to personnel or damage to equipment.

All operations concerning transport, installation, and commissioning as well as maintenance must be carried out by qualified, skilled personnel who are familiar with the installation, assembly, commissioning, and operation of variable frequency drives and the application for which it is being used.

Installation

Ensure proper handling and avoid excessive mechanical stress. Do not bend any components and do not change any insulation distances during transport, handling, installation or maintenance. Do not touch any electronic components or contacts. This drive contains electrostatically sensitive components, which can easily be damaged by inappropriate handling. Static control precautions must be adhered to during installation, testing, servicing and repairing of this drive and associated options. Component damage may result if proper procedures are not followed.



WARNING!

Drives must not be installed where subjected to adverse environmental conditions such as: combustible, oily, or hazardous vapors or dust; corrosive chemicals; excessive moisture; excessive vibration; direct sunlight or extreme temperatures. Contact Lenze-AC Tech for more information.

This drive has been tested by Underwriters Laboratory (UL) and is an approved component in compliance with UL508C Safety Standard. This drive must be installed and configured in accordance with both national and international standards. Local codes and regulations take precedence over recommendations provided in this and other Lenze-AC Tech documentation.

The SMVvector drive is considered a component for integration into a machine or process. It is neither a machine nor a device ready for use in accordance with European directives (reference machinery directive and electromagnetic compatibility directive). It is the responsibility of the end user to ensure that the machine meets the applicable standards.

Electrical Connection

When working on live drive controllers, applicable national safety regulations must be observed. The electrical installation must be carried out according to the appropriate regulations (e.g. cable cross-sections, fuses, protective earth [PE] connection). While this document does make recommendations in regards to these items, national and local codes must be adhered to.

The documentation contains information about installation in compliance with EMC (shielding, grounding, filters and cables). These notes must also be observed for CE-marked controllers. The manufacturer of the system or machine is responsible for compliance with the required limit values demanded by EMC legislation.

Application

The drive must not be used as a safety device for machines where there is a risk of personal injury or material damage. Emergency Stops, over-speed protection, acceleration and deceleration limits, etc must be made by other devices to ensure operation under all conditions.

The drive does feature many protection devices which are aimed at protecting the drive and the driven equipment by generating a fault and shutting the drive and motor down by removing power. Mains power variances can also result in shutdown of the drive. When the fault condition disappears or is cleared, the drive can be configured to automatically restart, it is the responsibility of the user and/or OEM and/or integrator to ensure that the drive is configured for safe operation.



Safety Information

Explosion Proof Applications

Explosion proof motors that are not rated for inverter use lose their certification when used for variable speed. Due to the many areas of liability that may be encountered when dealing with these applications, the following statement of policy applies:

AC Technology Corporation inverter products are sold with no warranty of fitness for a particular purpose or warranty of suitability for use with explosion proof motors. AC Technology Corporation accepts no responsibility for any direct, incidental or consequential loss, cost or damage that may arise through the use of AC inverter products in these applications. The purchaser expressly agrees to assume all risk of any loss, cost or damage that may arise from such application.

Operation





Systems including controllers must be equipped with additional monitoring and protection devices according to the corresponding standards (e.g. technical equipment, regulations for prevention of accidents, etc.). The controller may be adapted to your application as described in this documentation.

	<p>DANGER!</p> <ul style="list-style-type: none"> • After the controller has been disconnected from the supply voltage, live components and power connection must not be touched immediately, since capacitors could be charged. Please observe the corresponding notes on the controller. • Please close all protective covers and doors prior to and during operation. • Do not cycle input power to the controller more than once every two minutes.
---	---

Safety Notifications

All safety information given in these Operating Instructions has the same layout:

	<p>Signal Word! (characterizes the severity of the danger) Note (describes the danger and informs on how to proceed)</p>
---	---

Icon		Signal Words	
	Warning of hazardous electrical voltage	DANGER!	Warns of impending danger. Consequences if disregarded: Death or severe injuries.
	Warning of a general danger	WARNING!	Warns of potential, very hazardous situations. Consequences if disregarded: Death or severe injuries.
	Warning of damage to equipment	STOP!	Warns of potential damage to material and equipment. Consequences if disregarded: Damage to the controller/drive or its environment.
	Information	NOTE	Designates a general, useful note. If observed, then using the controller/drive system is made easier.

Safety Information



Safety Notifications in accordance with EN 61800-5-1:

	<p>DANGER! Hazard of Electrical Shock Capacitors retain charge for approximately 180 seconds after power is removed. Allow at least 3 minutes for discharge of residual charge before touching the drive.</p>
--	---

	<p>WARNING!</p> <ul style="list-style-type: none"> • This product can cause a d.c. current in the PE conductor. Where a residual current-operated (RCD) or monitoring (RCM) device is used for protection in case of direct or indirect contact, only an RCD or RCM Type B is allowed on the supply side of this product. • Leakage Current may exceed 3.5mA AC. The minimum size of the PE conductor shall comply with local safety regulations for high leakage current equipment. • In a domestic environment, this product may cause radio interference in which case supplementary mitigation measures may be required.
--	--

	<p>NOTE Control and communications terminals provide reinforced insulation when the drive is connected to a power system rated up to 300V rms between phase to ground (PE) and the applied voltage on Terminals 16 and 17 is less than 150VAC between phase and ground.</p>
--	---

Safety Notifications in accordance with UL:

Note for UL approved system with integrated controllers: UL warnings are notes which apply to UL systems. The documentation contains special information about UL.



- Suitable for use on a circuit capable of delivering not more than 200,000 rms symmetrical amperes, at the maximum voltage rating marked on the drive.
- Use minimum 75 °C copper wire only.
- Shall be installed in a pollution degree 2 macro-environment.



Technical Data

2 Technical Data

2.1 Standards and Application Conditions

Conformity	CE	Low Voltage (73/23/EEC) & EMC (89/336/EEC) Directives		
Approvals	UL508C	Underwriters Laboratories -Power Conversion Equipment		
Input voltage phase imbalance	≤ 2%			
Humidity	≤ 95% non-condensing			
Temperature range	Transport	-25 ... +70°C		
	Storage	-20 ... +70°C		
	Operation	-10 ... +55°C (with 2.5%/°C current derating above +40°C)		
Installation height	0 - 4000m a.m.s.l.	(with 5%/1000 m current derating above 1000m a.m.s.l.)		
Vibration resistance	acceleration resistant up to 1.0g			
⚠ Earth leakage current	> 3.5 mA to PE			
Enclosure	IP31/NEMA 1	IP65/NEMA 4X	IP54/NEMA 12	
Protection measures against	short circuit, earth fault, phase loss, over voltage, under voltage, motor stalling, over temperature, motor overload			

2.2 Ratings

2.2.1 NEMA 1 (IP 31) Ratings

120VAC Doubler / 240VAC Models

Type	Power [Hp/kW]	Mains			Output Current		Watts Loss
		Voltage ⁽¹⁾	I _n (120V)	I _n (240V)	I _n	CLim _{max} ⁽²⁾	
ESV251N01SXB	0.33 / 0.25	120 V Single-phase (1/N/PE) (90 ... 132 V) OR 240 V Single-phase (2/PE) (170 ... 264 V)	6.8	3.4	1.7	200	24
ESV371N01SXB	0.5 / 0.37		9.2	4.6	2.4	200	32
ESV751N01SXB	1 / 0.75		16.6	8.3	4.2	200	52

240VAC Models

Type	Power [Hp/kW]	Mains			Output Current		Watts Loss
		Voltage ⁽¹⁾	I _n 1~ (2/PE)	I _n 3~ (3/PE)	I _n	CLim _{max} ⁽²⁾	
ESV251N02SXB	0.33 / 0.25	240 V Single Phase (2/PE)	3.4	-	1.7	200	20
ESV371N02YXB	0.5 / 0.37	240 V Single-phase (2/PE) OR 240 V Three-phase (3/PE) (170 ... 264 V)	5.1	2.9	2.4	200	27
ESV751N02YXB	1 / 0.75		8.8	5.0	4.2	200	41
ESV112N02YXB	1.5 / 1.1		12.0	6.9	6.0	200	64
ESV152N02YXB	2 / 1.5		13.3	8.1	7.0	200	75
ESV222N02YXB	3 / 2.2		17.1	10.8	9.6	200	103



Type	Power [Hp/kW]	Mains			Output Current		Watts Loss
		Voltage ⁽¹⁾	I _{in 1- (2/PE)}	I _{in 3- (3/PE)}	I _n	CLim _{max} ⁽²⁾	
ESV112N02TXB	1.5 / 1.1	240 V Three-phase (3/PE) (170 V ... 264 V)	-	6.9	6.0	200	64
ESV152N02TXB	2 / 1.5		-	8.1	7.0	200	75
ESV222N02TXB	3 / 2.2		-	10.8	9.6	200	103
ESV402N02TXB	5 / 4.0		-	18.6	16.5	200	154
ESV552N02TXB	7.5 / 5.5		-	26	23	200	225
ESV752N02TXB	10 / 7.5		-	33	29	200	274

480VAC Models

Type	Power [Hp/kW]	Mains				Output Current		Watts Loss	
		Voltage ⁽¹⁾	I _n		CLim _{max} ⁽³⁾				
			400V	480V	400V	480V			
ESV371N04TXB	0.5 / 0.37	400 V Three-phase (3/PE) (340 ... 440 V) OR 480 V Three-phase (3/PE) (340 ... 528 V)	1.7	1.5	1.3	1.1	175	200	23
ESV751N04TXB	1 / 0.75		2.9	2.5	2.4	2.1	175	200	37
ESV112N04TXB	1.5 / 1.1		4.2	3.6	3.5	3.0	175	200	48
ESV152N04TXB	2 / 1.5		4.7	4.1	4.0	3.5	175	200	57
ESV222N04TXB	3 / 2.2		6.1	5.4	5.5	4.8	175	200	87
ESV402N04TXB	5 / 4.0		10.6	9.3	9.4	8.2	175	200	128
ESV552N04TXB	7.5 / 5.5		14.2	12.4	12.6	11.0	175	200	178
ESV752N04TXB	10 / 7.5		18.1	15.8	16.1	14.0	175	200	208

600VAC Models

Type	Power [Hp/kW]	Mains		Output Current		Watts Loss
		Voltage ⁽¹⁾	I _n	I _n	CLim _{max} ⁽²⁾	
ESV751N06TXB	1 / 0.75	600 V Three-phase (3/PE) (425 ... 660 V)	2.0	1.7	200	37
ESV152N06TXB	2 / 1.5		3.2	2.7	200	51
ESV222N06TXB	3 / 2.2		4.4	3.9	200	68
ESN402N06TXB	5 / 4.0		6.8	6.1	200	101
ESV552N06TXB	7.5 / 5.5		10.2	9	200	148
ESV752N06TXB	10 / 7.5		12.4	11	200	172

(1) Frequency Range: 48 Hz ... 62 Hz

(2) Current Limit (CLim) is a percentage of the output current, I_n. CLim_{max} is the maximum setting for P171.

(3) Current Limit (CLim) is a percentage of the output current, I_n. CLim_{max} is the maximum setting for P171.

For 480VAC models, the CLim_{max} value in the 480V column of the table is used when P107 is set to 1.

The CLim_{max} value in the 400V column is used when P107 is set to 0.



STOP!

- For installations above 1000m a.m.s.l., derate I_n by 5% per 1000m, do not exceed 4000m a.m.s.l.
- Operation above 40°C, derate I_n by 2.5% per °C, do not exceed 55°C.
- Carrier Frequency (P166):
 - If P166=2 (8 kHz), derate I_n to 92% of drive rating
 - If P166=3 (10 kHz), derate I_n to 84% of drive rating



Technical Data

2.2.2 NEMA 4X (IP65) Ratings

240VAC Models

Type	Power [Hp/kW]	Mains			Output Current		Watts Loss
		Voltage ⁽¹⁾	I _n 1- (2/PE)	I _n 3- (3/PE)	I _n	CLim _{max} ⁽²⁾	
ESV371N02SFC	0.5 / 0.37		240 V Single Phase (2/PE) (Integral Filters)	5.1	-	2.4	200
ESV751N02SFC	1 / 0.75	8.8		-	4.2	200	38 ⁽⁵⁾
ESV112N02SFC	1.5 / 1.1	12.0		-	6.0	200	59 ⁽⁵⁾
ESV152N02SFC	2 / 1.5	13.3		-	7.0	200	69 ⁽⁵⁾
ESV222N02SFC	3 / 2.2	17.1		-	9.6	200	93 ⁽⁵⁾
ESV371N02YXC	0.5 / 0.37	240 V Single-phase (2/PE) OR	5.1	2.9	2.4	200	26
ESV751N02YXC	1 / 0.75		8.8	5.0	4.2	200	38
ESV112N02YXC	1.5 / 1.1	240 V Three-phase (3/PE) (170 ... 264 V) (No Filters)	12.0	6.9	6.0	200	59
ESV152N02YXC	2 / 1.5		13.3	8.1	7.0	200	69
ESV222N02YXC	3 / 2.2		17.1	10.8	9.6	200	93

480VAC Models

Type	Power [Hp/kW]	Mains		Output Current				Watts Loss	
		Voltage ⁽¹⁾	I _n		CLim _{max} ⁽³⁾				
			400V	480V	400V	480V	400V		480V
ESV371N04T_C ⁽⁴⁾	0.5 / 0.37	400 V Three-phase (3/PE) (340 ... 440 V)	1.7	1.5	1.3	1.1	175	200	21 ⁽⁵⁾
ESV751N04T_C ⁽⁴⁾	1 / 0.75		2.9	2.5	2.4	2.1	175	200	33 ⁽⁵⁾
ESV112N04T_C ⁽⁴⁾	1.5 / 1.1	480 V Three-phase (3/PE) (340 ... 528 V)	4.2	3.6	3.5	3.0	175	200	42 ⁽⁵⁾
ESV152N04T_C ⁽⁴⁾	2 / 1.5		4.7	4.1	4.0	3.5	175	200	50 ⁽⁵⁾
ESV222N04T_C ⁽⁴⁾	3 / 2.2		6.1	5.4	5.5	4.8	175	200	78 ⁽⁵⁾

600VAC Models

Type	Power [Hp/kW]	Mains		Output Current		Watts Loss
		Voltage ⁽¹⁾	I _n	I _n	CLim _{max} ⁽²⁾	
ESV751N06TXC	1.0 / 0.75	600 V Three-phase (3/PE) (425 ... 660 V)	2.0	1.7	200	31
ESV152N06TXC	1.5 / 1.1		3.2	2.7	200	43
ESV222N06TXC	3.0 / 2.2		4.4	3.9	200	57

(1) Frequency Range: 48 Hz ... 62 Hz

(2) Current Limit (CLim) is a percentage of the output current, I_n. CLim_{max} is the maximum setting for P171.

(3) Current Limit (CLim) is a percentage of the output current, I_n. CLim_{max} is the maximum setting for P171.

For 480VAC models, the CLim_{max} value in the 480V column of the table is used when P107 is set to 1.

The CLim_{max} value in the 400V column is used when P107 is set to 0.

(4) The 11th digit of the Type number shown as a blank “_” is either an “F” = integral EMC filter or an “X” = no filter.

(5) For models with integral filters (those with an “F” in the 11th digit of the Type number) add 3 watts to the rated “Watts Loss” value.

	<p>STOP!</p> <ul style="list-style-type: none"> For installations above 1000m a.m.s.l., derate I_n by 5% per 1000m, do not exceed 4000m a.m.s.l. Operation above 40°C, derate I_n by 2.5% per °C, do not exceed 55°C. Carrier Frequency (P166): <ul style="list-style-type: none"> - If P166=1 (6 kHz), derate I_n to 92% of drive rating - If P166=2 (8 kHz), derate I_n to 84% of drive rating - If P166=3 (10 kHz), derate I_n to 76% of drive rating
--	--



2.3 SMV Type Number Designation

The table herein describes the Type numbering designation for the SMVector Inverter models.

	ESV	152	NO	2	T	X	B
Electrical Products in the SMVector Series							
Power Rating in kW:							
251 = 0.25kW (0.33HP)	402 = 4.0kW (5HP)						
371 = 0.37kW (0.5HP)	552 = 5.5kW (7.5HP)						
751 = 0.75kW (1HP)	752 = 7.5kW (10HP)						
112 = 1.1kW (1.5HP)							
152 = 1.5kW (2HP)							
222 = 2.2kW (3HP)							
Installed Communication Module:							
CO = CANopen							
DO = DeviceNet							
RO = RS-485 / ModBus							
NO = Communications not installed							
Input Voltage:							
1 = 120 VAC (doubler output) or 240 VAC							
2 = 240 VAC							
4 = 400/480 VAC							
6 = 600 VAC							
Input Phase:							
S = Single Phase Input only							
Y = Single or Three Phase Input							
T = Three Phase Input only							
Input Line Filter							
F = Integral EMC Filter							
X = Without EMC Filter							
Enclosure:							
B = NEMA 1 (IP31)							
C = NEMA 4X (IP65)							
D = NEMA 12 (IP54)							



Installation

3 Installation

3.1 Dimensions and Mounting

3.1.1 NEMA 1 (IP31)

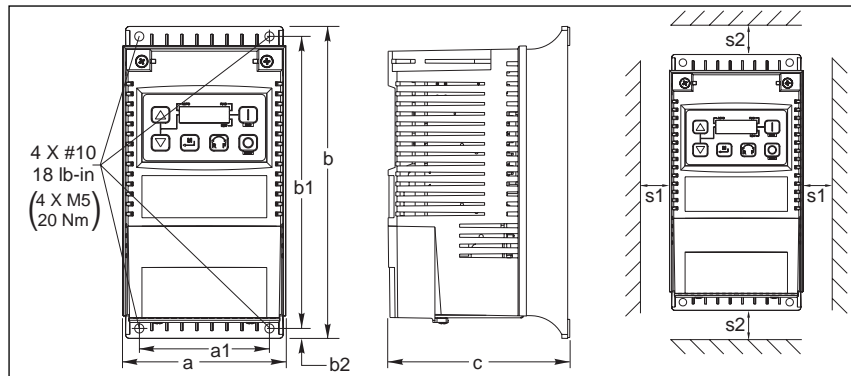

V0102

Type	a in (mm)	a1 in (mm)	b in (mm)	b1 in (mm)	b2 in (mm)	c in (mm)	s1 in (mm)	s2 in (mm)	m lb (kg)
ESV251-----B ESV371-----B ESV751-----B	3.90 (99)	3.10 (79)	7.50 (190)	7.00 (178)	0.25 (6)	4.35 (110)	0.6 (15)	2.0 (50)	2.0 (0.9)
ESV112-----B ESV152-----B ESV222-----B	3.90 (99)	3.10 (79)	7.50 (190)	7.00 (178)	0.25 (6)	5.45 (138)	0.6 (15)	2.0 (50)	2.8 (1.3)
ESV402-----B	3.90 (99)	3.10 (79)	7.50 (190)	7.00 (178)	0.25 (6)	5.80 (147)	0.6 (15)	2.0 (50)	3.2 (1.5)
ESV552-----B ESV752-----B	5.12 (130)	4.25 (108)	9.83 (250)	9.30 (236)	0.25 (6)	6.30 (160)	0.6 (15)	2.0 (50)	6.0 (2.0)



WARNING!

Drives must not be installed where subjected to adverse environmental conditions such as: combustible, oily, or hazardous vapors or dust; corrosive chemicals; excessive moisture; excessive vibration; direct sunlight or extreme temperatures. Contact Lenze-AC Tech for more information.



3.1.2 NEMA 4X (IP65)

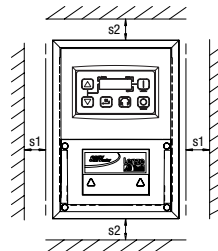
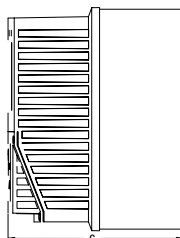
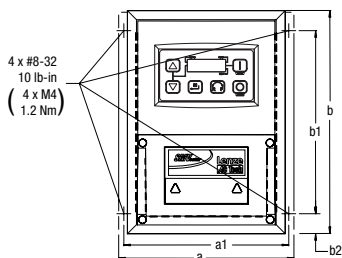

V0123

Type	a in (mm)	a1 in (mm)	b in (mm)	b1 in (mm)	b2 in (mm)	c in (mm)	s1 in (mm)	s2 in (mm)	m lb (kg)
ESV371N02YXC	6.28 (160)	5.90 (150)	8.00 (203)	6.56 (167)	0.66 (17)	4.47 (114)	2.00 (51)	2.00 (51)	2.9 (1.32)
ESV751N02YXC	6.28 (160)	5.90 (150)	8.00 (203)	6.56 (167)	0.66 (17)	4.47 (114)	2.00 (51)	2.00 (51)	2.9 (1.32)
ESV112N02YXC	6.28 (160)	5.90 (150)	8.00 (203)	6.56 (167)	0.72 (18)	6.27 (159)	2.00 (51)	2.00 (51)	5.1 (2.31)
ESV152N02YXC	6.28 (160)	5.90 (150)	8.00 (203)	6.56 (167)	0.72 (18)	6.27 (159)	2.00 (51)	2.00 (51)	5.3 (2.40)
ESV222N02YXC	7.12 (181)	6.74 (171)	8.00 (203)	6.56 (167)	0.72 (18)	6.77 (172)	2.00 (51)	2.00 (51)	6.5 (2.95)
ESV371N04TXC	6.28 (160)	5.90 (150)	8.00 (203)	6.56 (167)	0.66 (17)	4.47 (114)	2.00 (51)	2.00 (51)	3.0 (1.36)
ESV751N04TXC	6.28 (160)	5.90 (150)	8.00 (203)	6.56 (167)	0.66 (17)	4.47 (114)	2.00 (51)	2.00 (51)	3.0 (1.36)
ESV112N04TXC	6.28 (160)	5.90 (150)	8.00 (203)	6.56 (167)	0.72 (18)	6.27 (159)	2.00 (51)	2.00 (51)	5.2 (2.36)
ESV152N04TXC	6.28 (160)	5.90 (150)	8.00 (203)	6.56 (167)	0.72 (18)	6.27 (159)	2.00 (51)	2.00 (51)	5.2 (2.36)
ESV222N04TXC	6.28 (160)	5.90 (150)	8.00 (203)	6.56 (167)	0.72 (18)	6.27 (159)	2.00 (51)	2.00 (51)	5.3 (2.40)
ESV751N06TXC	6.28 (160)	5.90 (150)	8.00 (203)	6.56 (167)	0.66 (17)	4.47 (114)	2.00 (51)	2.00 (51)	3.0 (1.36)
ESV152N06TXC	6.28 (160)	5.90 (150)	8.00 (203)	6.56 (167)	0.72 (18)	6.27 (159)	2.00 (51)	2.00 (51)	5.3 (2.40)
ESV222N06TXC	6.28 (160)	5.90 (150)	8.00 (203)	6.56 (167)	0.72 (18)	6.27 (159)	2.00 (51)	2.00 (51)	5.3 (2.40)
ESV371N02SFC	6.28 (160)	5.90 (150)	8.00 (203)	6.56 (167)	0.66 (17)	4.47 (114)	2.00 (51)	2.00 (51)	3.5 (1.59)
ESV751N02SFC	6.28 (160)	5.90 (150)	8.00 (203)	6.56 (167)	0.66 (17)	4.47 (114)	2.00 (51)	2.00 (51)	3.5 (1.59)
ESV112N02SFC	6.28 (160)	5.90 (150)	8.00 (203)	6.56 (167)	0.72 (18)	6.27 (159)	2.00 (51)	2.00 (51)	5.7 (2.58)
ESV152N02SFC	6.28 (160)	5.90 (150)	8.00 (203)	6.56 (167)	0.72 (18)	6.27 (159)	2.00 (51)	2.00 (51)	5.9 (2.68)
ESV222N02SFC	7.12 (181)	6.74 (171)	8.00 (203)	6.56 (167)	0.72 (18)	6.27 (159)	2.00 (51)	2.00 (51)	6.5 (2.96)
ESV371N04TFC	6.28 (160)	5.90 (150)	8.00 (203)	6.56 (167)	0.66(17)	6.77 (172)	2.00 (51)	2.00 (51)	3.5 (1.59)
ESV751N04TFC	6.28 (160)	5.90 (150)	8.00 (203)	6.56 (167)	0.66 (17)	4.47 (114)	2.00 (51)	2.00 (51)	3.6 (1.63)
ESV112N04TFC	6.28 (160)	5.90 (150)	8.00 (203)	6.56 (167)	0.72 (18)	6.27 (159)	2.00 (51)	2.00 (51)	5.7 (2.58)
ESV152N04TFC	6.28 (160)	5.90 (150)	8.00 (203)	6.56 (167)	0.72 (18)	6.27 (159)	2.00 (51)	2.00 (51)	5.7 (2.58)
ESV222N04TFC	6.28 (160)	5.90 (150)	8.00 (203)	6.56 (167)	0.72 (18)	6.27 (159)	2.00 (51)	2.00 (51)	5.8 (2.63)



WARNING!

Drives must not be installed where subjected to adverse environmental conditions such as: combustible, oily, or hazardous vapors or dust; corrosive chemicals; excessive moisture; excessive vibration; direct sunlight or extreme temperatures. Contact Lenze-AC Tech for more information.



Installation

3.2 Electrical Installation

3.2.1 Power Connections



DANGER!

Hazard of electrical shock! Circuit potentials are up to 600 VAC above earth ground. Capacitors retain charge after power is removed. Disconnect power and wait at least three minutes before servicing the drive.



STOP!

- Verify mains voltage before connecting to drive.
- Do **not** connect mains power to the output terminals (U,V,W)! Severe damage to the drive will result.
- Do **not** cycle mains power more than once every 2 minutes. Damage to the drive will result.

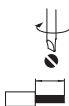

Mains and Motor Terminations

12 lb-in (1.3 Nm)

0.25 in (6mm)

3.2.1.1 Mains Connection to 120VAC Single-Phase Supply

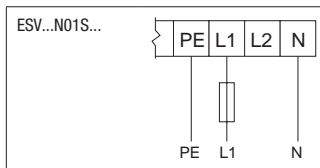

3.2.1.2 Mains Connection to 240VAC Single-Phase Supply

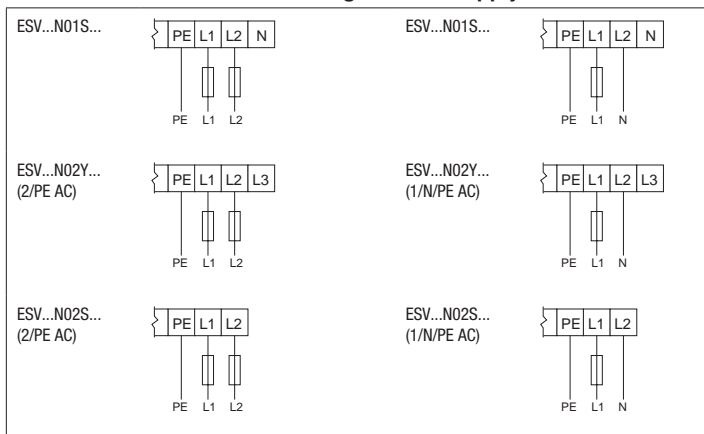



3.2.1.3 Mains Connection to Three-Phase Supply

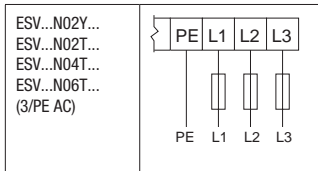

3.2.1.4 Motor Connection

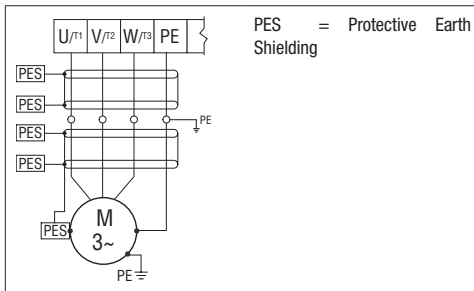

WARNING!

Leakage current may exceed 3.5 mA AC. The minimum size of the protective earth (PE) conductor shall comply with local safety regulations for high leakage current equipment.

3.2.1.5 Installation Recommendations for EMC Compliance

For compliance with EN 61800-3 or other EMC standards, motor cables, line cables and control or communications cables must be shielded with each shield/screen clamped to the drive chassis. This clamp is typically located at the conduit mounting plate.

Motor cable should be low capacitance (core/core <75pF/m, core/shield <150pF/m). Filtered drives can meet the class A limits of EN 55011 and EN 61800-3 Category 2 with this type of motor cable up to 10 meters.

Any external line filter should have its chassis connected to the drive chassis by mounting hardware or with the shortest possible wire or braid.



Installation

3.2.1.6 NEMA 4X (IP 65) Input Terminal Block

For NEMA 4X models with an integrated EMC filter, the input terminal block is located on the right-hand side of the SMV inverter in the NEMA 4X (IP 65) enclosure. The Single and Three Phase models are illustrated herein. Refer to paragraph 3.2.3 Control Terminals for pin out information.

Single Phase (2/PE) with Filter

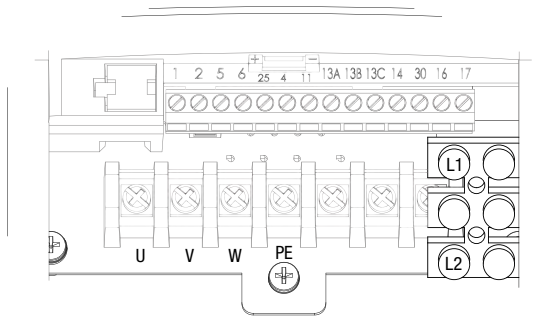

Three Phase (3/PE) with Filter

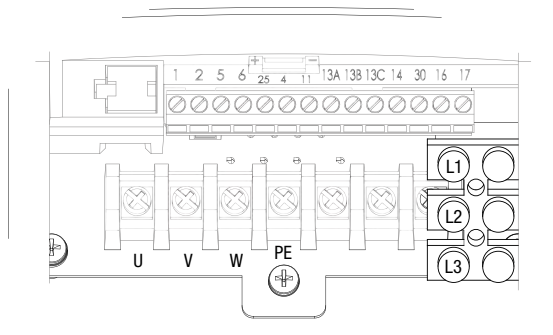



3.2.2 Fuses/Cable Cross-Sections

	NOTE Observe local regulations. Local codes may supersede these recommendations
--	---

Type		Recommendations					
		Fuse	Miniature circuit breaker ⁽¹⁾	Fuse ⁽²⁾ or Breaker ⁽³⁾ (N. America)	Input Power Wiring (L1, L2, L3, PE)		
					[mm ²]	[AWG]	
120V 1~ (1/N/PE)	ESV251N01SXB	M10 A	C10 A	10 A	1.5	14	
	ESV371N01SXB	M16 A	C16 A	15 A	2.5	14	
	ESV751N01SXB	M25 A	C25 A	25 A	4	10	
240V 1~ (2/PE)	ESV251N01SXB, ESV251N02SXB ESV371N01SXB, ESV371N02YXB ESV371N02SFC	M10 A	C10 A	10 A	1.5	14	
	ESV751N01SXB, ESV751N02YXB ESV751N02SFC	M16 A	C16 A	15 A	2.5	14	
	ESV112N02YXB, ESV112N02SFC	M20 A	C20 A	20 A	2.5	12	
	ESV152N02YXB, ESV152N02SFC	M25 A	C25 A	25 A	2.5	12	
	ESV222N02YXB, ESV222N02SFC	M32 A	C32A	32 A	4	10	
240V 3~ (3/PE)	ESV371N02YXB, ESV751N02YXB ESV371N02YXC, ESV751N02YXC	M10 A	C10 A	10 A	1.5	14	
	ESV112N02YXB, ESV152N02YXB ESV112N02TXB, ESV152N02TXB ESV112N02YXC, ESV152N02YXC	M16 A	C16 A	12 A	1.5	14	
	ESV222N02YXB, ESV222N02TXB ESV222N02YXC	M20 A	C20 A	20 A	2.5	12	
	ESV402N02TXB	M32 A	C32 A	32 A	4.0	10	
	ESV552N02TXB	M40 A	C40 A	35 A	6.0	8	
	ESV752N02TXB	M50 A	C50 A	45 A	10	8	
	400V or 480V 3~(3/PE)	ESV371N04TXB ...ESV222N04TXB ESV371N04TXC ...ESV222N04TXC ESV371N04TEC ...ESV222N04TEC	M10 A	C10 A	10 A	1.5	14
		ESV402N04TXB	M16 A	C16 A	20 A	2.5	14
ESV552N04TXB		M20 A	C20 A	20 A	2.5	14	
ESV752N04TXB		M25 A	C25 A	25 A	4.0	10	
600V 3~(3/PE)		ESV751N06TXB ...ESV222N06TXB ESV751N06TXC ...ESV222N06TXC	M10 A	C10 A	10 A	1.5	14
	ESV402N06TXB	M16 A	C16 A	12 A	1.5	14	
	ESV552N06TXB	M16 A	C16 A	15 A	2.5	14	
	ESV752N06TXB	M20 A	C20 A	20 A	2.5	12	

- (1) Installations with high fault current due to large supply mains may require a type D circuit breaker.
 (2) UL Class CC or T fast-acting current-limiting type fuses, 200,000 AIC, preferred. Bussman KTK-R, JJJ or JJS or equivalent.
 (3) Thermomagnetic type breakers preferred.

Observe the following when using Ground Fault Circuit Interrupters (GFCIs):

- Installation of GFCI only between supplying mains and controller.
- The GFCI can be activated by:
 - capacitive leakage currents between the cable screens during operation (especially with long, screened motor cables)
 - connecting several controllers to the mains at the same time
 - RFI filters



Installation

3.2.3 Control Terminals



NOTE

Control and communications terminals provide reinforced insulation when the drive is connected to a power system rated up to 300V rms between phase to ground and the applied voltage on Terminals 16 and 17 is less than 150VAC between phase and ground.

Terminal	Description	Important
1	Digital Input: Start/Stop	input resistance = 4.3kΩ
2	Analog Common	
5	Analog Input: 0...10 VDC	input resistance: >50 kΩ
6	Internal DC supply for speed pot	+10 VDC, max. 10 mA
25	Analog Input: 4...20 mA	input resistance: 250Ω
4	Digital Reference/Common	+15 VDC / 0 VDC, depending on assertion level
11	Internal DC supply for external devices	+12 VDC, max. 50 mA
13A	Digital Input: Configurable with P121	input resistance = 4.3kΩ
13B	Digital Input: Configurable with P122	
13C	Digital Input: Configurable with P123	
14	Digital Output: Configurable with P142	DC 24 V / 50 mA; NPN
30	Analog Output: Configurable with P150...P155	0...10 VDC, max. 20 mA
16	Relay output: Configurable with P140	AC 250 V / 3 A
17		DC 24 V / 2 A ... 240 V / 0.22 A, non-inductive

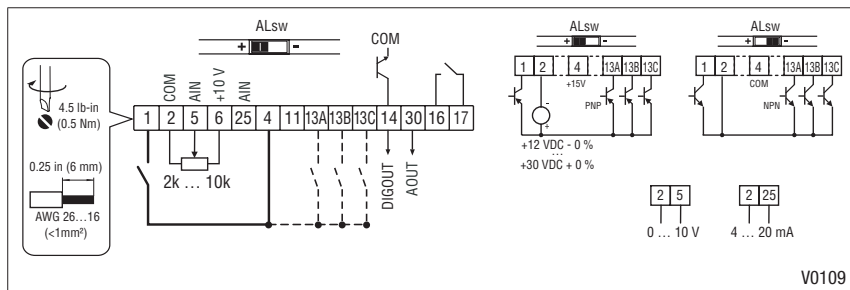

Assertion level of digital inputs

The digital inputs can be configured for active-high or active-low by setting the Assertion Level Switch (ALSw) and P120. If wiring to the drive inputs with dry contacts or with PNP solid state switches, set the switch and P120 to "High" (+). If using NPN devices for inputs, set both to "Low" (-). Active-high (+) is the default setting.

HIGH = +12 ... +30 V
 LOW = 0 ... +3 V



NOTE

An **F_{RL}** fault will occur if the Assertion Level switch (ALSw) position does not match the parameter P120 setting and P100 or any of the digital inputs (P121...P123) is set to a value other than 0.



4 Commissioning

4.1 Local Keypad & Display

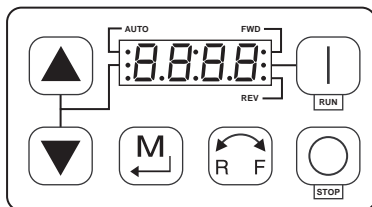

V0105



START BUTTON:

In Local Mode (P100 = 0, 4), this button will start the drive.



STOP BUTTON: stops the drive, regardless of which mode the drive is in.



WARNING!

When JOG is active, the STOP button will not stop the drive!



ROTATION:

In Local Mode (P100 = 0, 4), this selects the motor rotation direction:

- The LED for the present rotation direction (FWD or REV) will be on
- Press R/F; the LED for the opposite rotation direction will blink
- Press M within 4 seconds to confirm the change
- The blinking direction LED will turn on, and the other LED will turn off

When rotation direction is changed while the drive is running, the commanded direction LED will blink until the drive is controlling the motor in the selected direction.



MODE:

Used to enter/exit the Parameter Menu when programming the drive and to enter a changed parameter value.



UP AND DOWN BUTTONS:

Used for programming and can also be used as a reference for speed, PID setpoint, or torque setpoint.

When the ▲ and ▼ buttons are the active reference, the middle LED on the left side of the display will be on.



INDICATING LEDs

FWD/REV LEDs: Indicate the present rotation direction. See ROTATION above.

AUTO LED: Indicates that the drive has been put into Auto mode from one of the TB13 inputs (P121...P123 set to 1...7).

Also indicates that PID mode is active (if enabled).

RUN LED: Indicates that the drive is running

▲ ▼ LED: Indicates that the ▲ ▼ are the active reference.



NOTE

If the keypad is selected as the auto reference (P121...P123 is 6) and the corresponding TB-13 input is closed, then the AUTO LED and ▲ ▼ LEDs will both be on.



Commissioning

4.2 Drive Displays and Modes of Operation

Speed Mode Display

In the standard mode of operation, the drive frequency output is set directly by the selected reference (keypad, analog reference, etc.). In this mode, the drive display will show the drive's output frequency.

PID Mode Display

When the PID mode is enabled and active, the normal run display shows the actual PID setpoint. When PID mode is not active, the display returns to showing the drive's output frequency.

Torque Mode Display

When the drive is operating in Vector Torque mode, the normal run display shows the drive's output frequency.

4.3 Parameter Setting

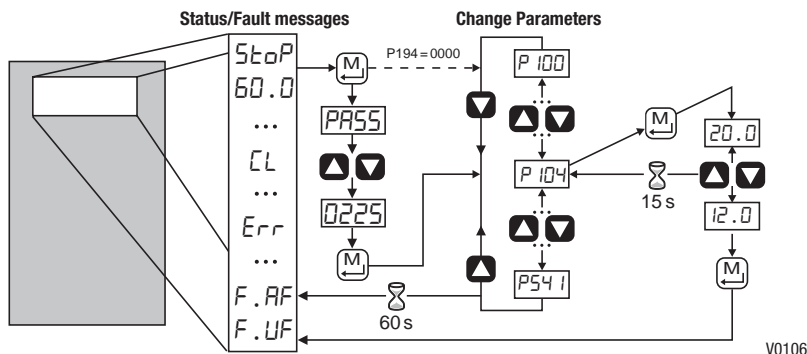

4.4 Electronic Programming Module (EPM)

The EPM contains the drives operational memory. Parameter settings are stored in the EPM and setting changes are made to the "User settings" in the EPM.

An optional EPM Programmer (model EEPM1RA) is available that allows:

- An EPM to be copied directly to another EPM.
- An EPM to be copied to the memory of the EPM Programmer.
- Stored files can be modified in the EPM Programmer.
- Stored files can be copied to another EPM.



EPM Module
in SMV Drive

As the EPM Programmer is battery operated, parameter settings can be copied to an EPM and inserted into a drive without power being applied to the drive. This means that the drive will be fully operational with the new settings on the next application of power.



Additionally, when the drives parameter settings are burned into an EPM with the EPM Programmer, the settings are saved in two distinct locations; the "User settings" and the "OEM default settings". While the User settings can be modified in the drive, the OEM settings cannot. Thus, the drive can be reset not only to the "factory" drive default settings (shown in this manual), but can be set to the Original Machine settings as programmed by the OEM.

While the EPM can be removed for copying or to use in another drive, it must be installed for the drive to operate (a missing EPM will trigger an F_F I fault).



4.5 Parameter Menu

4.5.1 Basic Setup Parameters

Code		Possible Settings		IMPORTANT
No.	Name	Default	Selection	
P100	Start Control Source	0	0 Local Keypad	Use RUN button on front of drive to start
			1 Terminal Strip	Use start/stop circuit wired into the terminal strip. Refer to Section 3.2.3
			2 Remote Keypad Only	Use RUN button on optional Remote Keypad to start
			3 Network Only	<ul style="list-style-type: none"> Start command must come from network (Modbus, CANopen, etc) Requires optional communication module (refer to the network module documentation). Must also set one of the TB-13 inputs to 9 (Network Enable); refer to P121...P123
			4 Terminal Strip or Local Keypad	Allows start control to be switched between terminal strip and local keypad using one of the TB-13 inputs. See note below.
			5 Terminal Strip or Remote Keypad	Allows start control to be switched between terminal strip and optional remote keypad using one of the TB-13 inputs. See note below.
 WARNING! P100 = 0 disables TB-1 as a STOP input! STOP circuitry may be disabled if parameters are reset back to defaults (see P199)				
 NOTE <ul style="list-style-type: none"> P100 = 4, 5: To switch between control sources, one of the TB-13 inputs (P121...P123) must be set to 08 (Control Select); TB-13x OPEN (or not configured): Terminal strip control TB-13x CLOSED: Local (P100 = 4) or Remote (P100 = 5) keypad P100 = 0, 1, 4: Network can take control if P121...P123 = 9 and the corresponding TB-13x input is CLOSED. The STOP button on the front of the drive is always active except in JOG mode. An F_{AL} fault will occur if the Assertion Level switch (ALsw) position does not match the P120 setting and P100 is set to a value other than 0. 				
P101	Standard Reference Source	0	0 Keypad (Local or Remote)	Selects the default speed or torque reference when no Auto Reference is selected using the TB-13 inputs
			1 0-10 VDC	
			2 4-20 mA	
			3 Preset #1	
			4 Preset #2	
			5 Preset #3	
			6 Network	





Commissioning

Code		Possible Settings				IMPORTANT
No.	Name	Default	Selection			
P 102	Minimum Frequency	0.0	0.0	{Hz}	P103	<ul style="list-style-type: none"> P102, P103 are active for all speed references When using an analog speed reference, also see P160, P161
P 103	Maximum Frequency	60.0	7.5	{Hz}	500	
		<p>NOTE</p> <ul style="list-style-type: none"> P103 cannot be set below Minimum Frequency (P102) To set P103 above 120 Hz: <ul style="list-style-type: none"> - Scroll up to 120 Hz; display shows H FR (flashing). - Release s button and wait one second - Press s button again to continue increasing P103 				
<p>WARNING!</p> <p>Consult motor/machine manufacturer before operating above rated frequency. Overspeeding the motor/machine may cause damage to equipment and injury to personnel!</p>						
P 104	Acceleration Time 1	20.0	0.0	{s}	3600	<ul style="list-style-type: none"> P104 = time of frequency change from 0 Hz to P167 (base frequency) P105 = time of frequency change from P167 to 0 Hz For S-ramp accel/decel, adjust P106
P 105	Deceleration Time 1	20.0	0.0	{s}	3600	
		<p>i Example: if P103 = 120 Hz, P104 = 20.0 s and P167 (base frequency) = 60 Hz; the rate of frequency change from 0 Hz to 120 Hz = 40.0 s</p>				
P 106	S-Ramp Integration Time	0.0	0.0	{s}	50.0	<ul style="list-style-type: none"> P106 = 0.0: Linear accel/decel ramp P106 > 0.0: Adjusts S-ramp curve for smoother ramp
P 107 ⁽¹⁾	Line Voltage Selection	1*	0 Low (120, 200, 400, 480VAC)			<p>* The default setting is 1 for all drives except when using "reset 50" (Parameter P199, selection 4) with 480V models. In this case, the default setting is 0.</p>
			1 High (120, 240, 480, 600VAC)			
P 108	Motor Overload	100	30	{%}	100	<p>P108 = $\frac{\text{motor current rating} \times 100}{\text{SMV output rating}}$</p> <p>Example: if motor = 3amps and SMV = 4amps, then P108 = 75%</p>
		<p>NOTE</p> <p>Do not set above rated motor current as listed on the motor dataplate. The motor thermal overload function of the SMV is UL approved as a motor protection device. If the line power is cycled, the motor thermal state is reset to cold state. Cycling power after an overload fault could result in significantly reducing the motor life.</p>				
P 109	Motor Overload Type	0	0 Speed Compensation			
			1 No Speed Compensation			

(1) Any changes to this parameter will not take effect until the drive is stopped

Commissioning



Code		Possible Settings		IMPORTANT
No.	Name	Default	Selection	
P110	Start Method	0	0 Normal	
			1 Start on Power-up	Drive will automatically start when power is applied.
			2 Start with DC Brake	When start command is applied, drive will apply DC braking according to P174, P175 prior to starting the motor
			3 Auto Restart	Drive will automatically restart after faults, or when power is applied.
			4 Auto Restart with DC Brake	Combines settings 2 and 3
			5 Flying Start/Restart #1	<ul style="list-style-type: none"> Drive will automatically restart after faults, or when power is applied. After 3 failed attempts, drive will Auto Restart with DC brake. P110 = 5: Performs speed search, starting at Max Frequency (P103)
			6 Flying Start/Restart #2	<ul style="list-style-type: none"> P110 = 6: Performs speed search, starting at the last output frequency prior to faulting or power loss If P111 = 0, a flying START is performed when a start command is applied.
			 NOTE <ul style="list-style-type: none"> P110 = 0, 2: Start command must be applied at least 2 seconds after power-up; F_{UF} fault will occur if start command is applied too soon. P110 = 1, 3...6: For automatic start/restart, the start source must be the terminal strip and the start command must be present. P110 = 2, 4...6: If P175=999.9, dc braking will be applied for 15s. P110 = 3...6: Drive will attempt 5 restarts; if all restart attempts fail, drive displays LC (fault lockout) and requires manual reset. P110 = 5, 6: If drive cannot catch the spinning motor, drive will trip into F_{rF} fault. 	
 WARNING! Automatic starting/restarting may cause damage to equipment and/or injury to personnel! Automatic starting/restarting should only be used on equipment that is inaccessible to personnel.				
P111	Stop Method	0	0 Coast	Drive's output will shut off immediately upon a stop command, allowing the motor to coast to a stop
			1 Coast with DC Brake	The drive's output will shut off and then the DC Brake will activate (see P174, P175)
			2 Ramp	The drive will ramp the motor to a stop according to P105 or P126.
			3 Ramp with DC Brake	The drive will ramp the motor to 0 Hz and then the DC Brake will activate (see P174, P175)
P112	Rotation	0	0 Forward Only	If PID mode is enabled, reverse direction is disabled (except for Jog).
			1 Forward and Reverse	



Commissioning

4.5.2 I/O Setup Parameters

Code		Possible Settings		IMPORTANT
No.	Name	Default	Selection	
P 120	Assertion Level	2	1 Low 2 High	P120 and the Assertion Level switch must both match the desired assertion level unless P100, P121...P123 are all set to 0. Otherwise an F_{RL} fault will occur.
P 121	TB-13A Input Function	0	0 None	Disables input
P 122	TB-13B Input Function		1 AUTO Reference: 0-10 VDC	For frequency mode, see P160...P161, For PID mode, see P204...P205, For vector torque mode, see P330
			2 AUTO Reference: 4-20 mA	
P 123	TB-13C Input Function		3 AUTO Reference: Preset	For frequency mode see P131...P137, For PID mode, see P231...P233, For torque mode see, P331...P333
			4 AUTO Reference: MOP Up	• Normally open: Close input to increase or decrease speed, PID setpoint or torque setpoint. • MOP Up is not active while in STOP
			5 AUTO Reference: MOP Down	
			6 AUTO Reference: Keypad	
			7 AUTO Reference: Network	
			8 Control Select	Use when P100 = 4, 5 to switch between terminal strip control and local or remote keypad control.
			9 Network Enable	Required to start the drive through the network.
			10 Reverse Rotation	Open = Forward Closed = Reverse
			11 Start Forward	
			12 Start Reverse	See note for typical circuit
13 Run Forward				
14 Run Reverse	See note for typical circuit			
15 Jog Forward	Jog Forward speed = P134			
16 Jog Reverse	Jog Reverse speed = P135 Active even if P112 = 0			
17 Accel/Decel #2	Refer to parameters P125, P126			
18 DC Brake	See P174; close input to override P175			
19 Auxiliary Ramp to Stop	Normally closed: Opening input will ramp drive to STOP according to P127, even if P111 is set to Coast (0 or 1).			
20 Clear Fault	Close to reset fault			
21 External Fault F_{EF}	Normally closed circuit; open to trip			
22 Inverse External Fault F_{EF}	Normally open circuit; close to trip			
WARNING! Jog overrides all STOP commands! To stop the drive while in Jog mode, the Jog input must be deactivated or a fault condition induced.				

Commissioning



Code		Possible Settings				IMPORTANT																																
No.	Name	Default	Selection																																			
<p>NOTE</p> <ul style="list-style-type: none"> When input is activated, settings 1...7 override P101. When TB-13A...TB-13C are configured for Auto References other than MOP, TB-13C overrides TB-13B, and TB-13B overrides TB-13A. Any other Auto Reference will have priority over MOP. Settings 10...14 are only valid in Terminal Strip mode (P100 = 1, 4, 5). If Start/Run/Jog Forward and Start/Run/Jog Reverse are both activated, drive will STOP. If Jog input is activated while the drive is running, the drive will enter Jog mode; when Jog input is deactivated, drive will STOP. An F..RL fault will occur if the Assertion Level switch (ALSw) position does not match the P120 setting and any of the digital inputs (P121...P123) are set to a value other than 0. An F..I L fault will occur under the following conditions: <ul style="list-style-type: none"> TB-13A...TB-13C settings are duplicated (each setting, except 0 and 3, can only be used once). One input is set to "MOP Up" and another is not set to "MOP Down", or vice-versa. One input is set to 10 and another input is set to 11...14. One input is set to 11 or 12 and another input is set for 13 or 14. Typical control circuits are shown below: <ul style="list-style-type: none"> If any input is set to 10, 12 or 14, P112 must be set to 1 for Reverse action to function. <div style="display: flex; justify-content: space-around; margin-top: 10px;"> <div style="text-align: center;"> <p>Run / Stop with Direction P121 = 10</p> </div> <div style="text-align: center;"> <p>Start Forward / Start Reverse P121 = 11, P122 = 12</p> </div> <div style="text-align: center;"> <p>Run Forward / Run Reverse P121 = 13, P122 = 14</p> </div> </div>																																						
P 125	Acceleration Time 2	20.0	0.0	{s}	3600	<ul style="list-style-type: none"> Selected using TB-13A...TB-13C (P121... P123 = 17) For S-ramp accel/decel, adjust P106 																																
P 126	Deceleration Time 2	20.0	0.0	{s}	3600																																	
P 127	Deceleration Time for Auxiliary Ramp to Stop	20.0	0.0	{s}	3600	<ul style="list-style-type: none"> Selected using TB-13A...TB-13C (P121... P123 = 19). For S-ramp accel/decel, adjust P106 Once executed, this ramp time has priority over P105 and P126. 																																
P 131	Preset Speed #1	0.0	0.0	{Hz}	500	<table border="1" style="width: 100%; text-align: center;"> <thead> <tr> <th>PRESET SPEED</th> <th>13A</th> <th>13B</th> <th>13C</th> </tr> </thead> <tbody> <tr><td>1</td><td>X</td><td>--</td><td>--</td></tr> <tr><td>2</td><td>--</td><td>X</td><td>--</td></tr> <tr><td>3</td><td>--</td><td>--</td><td>X</td></tr> <tr><td>4</td><td>X</td><td>X</td><td>--</td></tr> <tr><td>5</td><td>X</td><td>--</td><td>X</td></tr> <tr><td>6</td><td>--</td><td>X</td><td>X</td></tr> <tr><td>7</td><td>X</td><td>X</td><td>X</td></tr> </tbody> </table>	PRESET SPEED	13A	13B	13C	1	X	--	--	2	--	X	--	3	--	--	X	4	X	X	--	5	X	--	X	6	--	X	X	7	X	X	X
PRESET SPEED	13A	13B	13C																																			
1	X	--	--																																			
2	--	X	--																																			
3	--	--	X																																			
4	X	X	--																																			
5	X	--	X																																			
6	--	X	X																																			
7	X	X	X																																			
P 132	Preset Speed #2	0.0	0.0	{Hz}	500																																	
P 133	Preset Speed #3	0.0	0.0	{Hz}	500																																	
P 134	Preset Speed #4	0.0	0.0	{Hz}	500																																	
P 135	Preset Speed #5	0.0	0.0	{Hz}	500																																	
P 136	Preset Speed #6	0.0	0.0	{Hz}	500																																	
P 137	Preset Speed #7	0.0	0.0	{Hz}	500																																	



Commissioning

Code		Possible Settings		IMPORTANT
No.	Name	Default	Selection	
P 140	Relay Output TB-16, 17	0	0 None	Disables the output
			1 Run	Energizes when the drive is running
			2 Reverse	Energizes when reverse rotation is active
			3 Fault	De-energizes when the drive trips, or power is removed
			4 Inverse Fault	Energizes when the drive trips
			5 Fault Lockout	P110 = 3..6: De-energizes if all restart attempts fail
			6 At Speed	Energizes when output frequency = commanded frequency
			7 Above Preset Speed #6	Energizes when output freq. > P136
			8 Current Limit	Energizes when motor current = P171
			9 Follower Loss (4-20 mA)	Energizes when 4-20 mA signal falls below 2 mA
			10 Loss of Load	Energizes when motor load drops below P145; see also P146
			11 Local Keypad Control Active	Energizes when the selected source is active for start control
			12 Terminal Strip Control Active	
			13 Remote Keypad Control Active	
			14 Network Control Active	
			15 Standard Reference Active	Energizes when P101 reference is active
			16 Auto Reference Active	Energizes when Auto Reference is activated using TB-13 input; refer to P121...P123
			17 Sleep Mode Active	Refer to parameters P240...P242
			18 PID Feedback < Min. Alarm	Energizes when PID feedback signal < P214
			19 Inverse PID Feedback < Min. Alarm	De-energizes when PID feedback signal < P214
			20 PID Feedback > Max Alarm	Energizes when PID feedback signal > P215
			21 Inverse PID Feedback > Max Alarm	De-energizes when PID feedback signal > P215
			22 PID Feedback within Min/Max Alarm range	Energizes when PID feedback signal is within the Min/Max Alarm range; see P214, P215
			23 PID Feedback outside Min/Max Alarm range	Energizes when PID feedback signal is outside the Min/Max Alarm range; see P214, P215
			24 Reserved	
25 Network Activated	Requires optional communication module (refer to the network module documentation).			

Commissioning



Code		Possible Settings				IMPORTANT
No.	Name	Default	Selection			
P 142	TB-14 Output	0	0...23 (same as P140) 24 Dynamic Braking 25 Network Activated			For use with Dynamic Braking option Requires optional communication module (refer to the network module documentation).
P 145	Loss of Load Threshold	0	0	{%}	200	P140, P142 = 10: Output will energize if motor load falls below P145 value longer than P146 time
P 146	Loss of Load Delay	0.0	0.0	{s}	240.0	
P 150	TB-30 Output	0	0 None			2-10 VDC signal can be converted to 4-20 mA with a total circuit impedance of 500 Ω
			1 0-10 VDC Output Frequency			
			2 2-10 VDC Output Frequency			
			3 0-10 VDC Load			
			4 2-10 VDC Load			
			5 0-10 VDC Torque			
			6 2-10 VDC Torque			
			7 0-10 VDC Power (kW)			
			8 2-10 VDC Power (kW)			
			9 Network Controlled			Requires optional communication module (refer to the network module documentation).
P 152	TB-30 Scaling: Frequency	60.0	3.0	{Hz}	2000	If P150 = 1 or 2, sets the frequency at which output equals 10 VDC
P 153	TB-30 Scaling: Load	200	10	{%}	500	If P150 = 3 or 4, sets the Load (as a percent of drive current rating) at which output equals 10 VDC.
P 154	TB-30 Scaling: Torque	100	10	{%}	1000	If P150 = 5 or 6, sets the Torque (as a percent of motor rated torque) at which output equals 10 VDC
P 155	TB-30 Scaling: Power (kW)	1.0	0.1	{kW}	200.0	If P150 = 7 or 8, sets the power at which output equals 10 VDC



Commissioning

4.5.3 Advanced Setup Parameters

Code		Possible Settings				IMPORTANT
No.	Name	Default	Selection			
P 160	Speed at Minimum Signal	0.0	-999.0	{Hz}	1000	<p style="text-align: right;">V0111</p>
P 161	Speed at Maximum Signal	60.0	-999.0	{Hz}	1000	
		NOTE <ul style="list-style-type: none"> • P160 sets the output frequency at 0% analog input • P161 sets the output frequency at 100% analog input • P160 or P161 < 0.0 Hz: For scaling purposes only; does not indicate opposite direction! • P160 > P161: Drive will react inversely to analog input signal 				
P 162	Analog Input Filter	0.01	0.00	{s}	10.00	Adjusts the filter on the analog inputs (TB-5 and TB-25) to reduce the effect of signal noise
P 163	TB-25 Loss Action	0	0 No Action 1 Fault F_{FaL} 2 Go to Preset when TB-25 is: Speed reference: P137 PID feedback source: P137 PID setpoint reference: P233 Torque reference: P333			<ul style="list-style-type: none"> • Selects the reaction to a loss of the 4-20 mA signal at TB-25. • Signal is considered lost if it falls below 2 mA • Digital outputs can also indicate a loss of 4-20 mA signal; refer to P140, P142
P 166	Carrier Frequency	See Notes	0 4 kHz 1 6 kHz 2 8 kHz 2 10 kHz			<ul style="list-style-type: none"> • As carrier frequency is increased, motor noise is decreased • Observe derating in Section 2.2.2 and 2.2.3 • Automatic shift to 4 kHz at 120% load • NEMA 4X (IP65) Models: Default = 0 (4kHz) • NEMA 1 (IP31) Models: Default = 1 (6kHz)
P 167 ⁽¹⁾	Base Frequency	60.0	10.0	{Hz}	1500	<p style="text-align: right;">V0112</p>
P 168	Fixed Boost		0.0	{%}	30.0	
		NOTE <ul style="list-style-type: none"> • P167 = rated motor frequency for standard applications • P168 = default setting depends on drive rating 				
P 169	Accel Boost	0.0	0.0	{%}	20.0	Accel Boost is only active during acceleration

(1) Any changes to this parameter will not take effect until the drive is stopped

Commissioning





Code		Possible Settings				IMPORTANT
No.	Name	Default	Selection			
P 170	Slip Compensation	0.0	0.0	{%}	10.0	Increase P170 until the motor speed no longer changes between no load and full load conditions.
P 171 ⁽¹⁾	Current Limit	200	30	{%}	CLim _{max}	<ul style="list-style-type: none"> When the limit is reached, the drive displays CL, and either the acceleration time increases or the output frequency decreases. Digital outputs can also indicate when the limit is reached; refer to P140, P142. Refer to Section 2.2 for CLim_{max}
P 174	DC Brake Voltage	0.0	0.0	{%}	30.0	Setting is a percent of the nominal DC bus voltage.
P 175	DC Brake Time	0.0	0.0	{s}	999.9	
		NOTE CONFIRM MOTOR SUITABILITY FOR USE WITH DC BRAKING DC Brake voltage (P174) is applied for the time specified by P175 with the following exceptions: <ul style="list-style-type: none"> If P111=1, 3 and P175=999.9 the brake voltage will be applied continuously until a run or fault condition occurs. If P110=2, 4...6 and P175=999.9, brake voltage will be applied for 15s If P121...P123=18 and the corresponding TB-13 input is CLOSED, brake voltage will be applied until the TB-13 input is OPENED or a fault condition occurs. 				
P 178	Display Frequency Multiplier	0.00	0.00		650.00	<ul style="list-style-type: none"> Allows frequency display to be scaled P178 = 0.00: Scaling disabled P178 > 0.00: Display = Actual Frequency X P178
		Example: If P178 = 29.17 and actual frequency = 60 Hz, then Drive displays 1750 (rpm)				
P 179	Run Screen Display	0	0	{Parameter Number}	599	<ul style="list-style-type: none"> 0 = Normal Run Screen, this display depends on mode of operation. Refer to Section 4.2. Other selections choose a diagnostic parameter to display (P501...P599).
P 181	Skip frequency 1	0.0	0.0	{Hz}	500	<ul style="list-style-type: none"> Drive will not run in the defined skip range; used to skip over frequencies that cause mechanical vibration P181 and P182 define the start of the skip ranges P184 > 0 defines the bandwidth of both ranges.
P 182	Skip frequency 2	0.0	0.0	{Hz}	500	
P 184	Skip frequency bandwidth	0.0	0.0	{Hz}	10.0	
		NOTE Bandwidth (Hz) = f_s (Hz) + P184 (Hz) f_s = P181 or P182 Example: P181 = 18 Hz and P184 = 4 Hz; skip range is from 18 to 22 Hz				

(1) Any changes to this parameter will not take effect until the drive is stopped



Commissioning

Code		Possible Settings		IMPORTANT
No.	Name	Default	Selection	
P 194	Password	225	0000 9999	<ul style="list-style-type: none"> • Must enter password to access parameters • P194 = 0000: Disables password
P 197	Clear Fault History	0	0 No Action 1 Clear Fault History	
P 199	Program Selection		0 Operate from User settings 1 Operate from OEM settings 2 Reset to OEM default settings 3 Reset to 60 Hz default settings 4 Reset to 50 Hz default settings 5 Translate	Refer to Notes 1, 2 and 3 Refer to Note 1 <ul style="list-style-type: none"> • Refer to Note 4 • Parameters are reset to the defaults listed in this manual. • For P199=4, the following exceptions apply: <ul style="list-style-type: none"> - P103, P152, P161, P167 = 50.0 Hz - P304 = 50 Hz; - P305 = 1450 RPM - P107 = 0 (480 V drives only) Refer to Note 5
			 WARNING! Modification of P199 can affect drive functionality! STOP and EXTERNAL FAULT circuitry may be disabled! Check P100 and P121...P123	
			 Note 1 If the EPM does not contain valid OEM settings, a flashing $\mathcal{G}F$ will be displayed when P199 is set to 1 or 2. Note 2 When P199 is set to 1, the drive operates from the OEM settings stored in the EPM Module and no other parameters can be changed ($\mathcal{G}E$ will be displayed if attempted). Note 3 Auto Calibration is not possible when operating from OEM Settings. Note 4 Reset 60 and Reset 50 will set the Assertion Level (P120) to "2" (High). P120 may need to be reset for the digital input devices being used. An F_RL fault may occur if P120 and the Assertion switch are not set identically. Note 5 If an EPM that contains data from a previous compatible software version is installed: <ul style="list-style-type: none"> • The drive will operate according to the previous data, but parameters cannot be changed ($\mathcal{G}E$ will be displayed if attempted) • To update the EPM to the current software version, set P199 = 5. The parameters can now be changed but the EPM is incompatible with previous software revisions. 	



4.5.4 PID Parameters

Code		Possible Settings				IMPORTANT
No.	Name	Default	Selection			
P200	PID Mode	0	0	Disabled		<ul style="list-style-type: none"> Normal-acting: As feedback increases, motor speed decreases Reverse-acting: As feedback increases, motor speed increases PID mode is disabled in Vector Torque mode (P300 = 5)
			1	Normal-acting		
			2	Reverse-acting		
			NOTE To activate PID mode, one of the TB-13 inputs (P121...P123) must be used to select the Auto Reference that matches the desired PID setpoint reference. If the selected PID setpoint reference uses the same analog signal as the PID feedback (P201), an F₁ L fault will occur. Example: The desired PID setpoint reference is the keypad (▲ and ▼). Set TB-13x = 6 (Auto Reference: Keypad): <ul style="list-style-type: none"> TB-13x = closed: PID mode is active TB-13x = open: PID mode is disabled and the drive speed will be controlled by the reference selected in P101. 			
P201	PID Feedback Source	0	0	4-20 mA (TB-25)		Must be set to match the PID feedback signal
			1	0-10 VDC (TB-5)		
P202	PID Decimal Point	1	0	PID Display = XXXX		Applies to P204, P205, P214, P215, P231... P233, P242, P522, P523
			1	PID Display = XXX.X		
			2	PID Display = XX.XX		
			3	PID Display = X.XXX		
			4	PID Display = .XXXX		
P204	Feedback at Minimum Signal	0.0	-99.9		3100.0	Set to match the range of the feedback signal being used
P205	Feedback at Maximum Signal	100.0	-99.9		3100.0	Example: Feedback signal is 0 - 300 PSI; P204 = 0.0, P205 = 300.0
P207	Proportional Gain	5.0	0.0	{%}	100.0	Used to tune the PID loop: <ul style="list-style-type: none"> Increase P207 until system becomes unstable, then decrease P207 by 10-15% Next, increase P208 until feedback matches setpoint If required, increase P209 to compensate for sudden changes in feedback
P208	Integral Gain	0.0	0.0	{s}	20.0	
P209	Derivative Gain	0.0	0.0	{s}	20.0	
			NOTE <ul style="list-style-type: none"> Derivative Gain is very sensitive to noise on the feedback signal and must be used with care Derivative Gain is not normally required in pump and fan applications 			
P210	PID Setpoint Ramp	20.0	0.0	{s}	100.0	<ul style="list-style-type: none"> Time of setpoint change from P204 to P205 or vice versa. Used to smooth the transition from one PID setpoint to another, such as when using the Preset PID Setpoints (P231...P233)



Commissioning

Code		Possible Settings			IMPORTANT
No.	Name	Default	Selection		
P214	Minimum Alarm	0.0	P204	P205	Use with P140, P142 = 18...23
P215	Maximum Alarm	0.0	P204	P205	
P231	Preset PID Setpoint #1	0.0	P204	P205	TB-13A activated; P121 = 3 and P200 = 1 or 2
P232	Preset PID Setpoint #2	0.0	P204	P205	TB-13B activated; P122 = 3 and P200 = 1 or 2
P233	Preset PID Setpoint #3	0.0	P204	P205	TB-13C activated; P123 = 3 and P200 = 1 or 2
P240	Sleep Threshold	0.0	0.0	{Hz} 500.0	<ul style="list-style-type: none"> If drive speed < P240 for longer than P241, output frequency = 0.0 Hz; drive display = SLP P240 = 0.0: Sleep mode is disabled. P200 = 0...2: Drive will start again when speed command is above P240 P242 > 0.0: Drive will restart when the PID feedback differs from the setpoint by more than the value of P242 or when the PID loop requires a speed above P240.
P241	Sleep Delay	30.0	0.0	{s} 300.0	
P242	Sleep Bandwidth	0.0	0.0	B _{max}	

Where: $B_{max} = |(P205 - P204)|$



4.5.5 Vector Parameters

Code		Possible Settings		IMPORTANT		
No.	Name	Default	Selection			
P300 ⁽¹⁾	Drive Mode	0	0 Constant V/Hz	Constant torque V/Hz control for general applications		
			1 Variable V/Hz	Variable torque V/Hz control for centrifugal pump and fan applications		
			2 Enhanced Constant V/Hz	For single or multiple motor applications that require better performance than settings 0 or 1, but cannot use Vector mode, due to: <ul style="list-style-type: none"> • Missing required motor data • Vector mode causing unstable motor operation 		
			3 Enhanced Variable V/Hz			
			4 Vector Speed	For single-motor applications requiring higher starting torque and speed regulation		
			5 Vector Torque	For single-motor applications requiring torque control independent of speed		
		NOTE To configure the drive for either Vector mode or Enhanced V/Hz mode: <ul style="list-style-type: none"> • P300 = 4, 5: <ul style="list-style-type: none"> - Set P302...P306 according to motor nameplate - Set P399 = 1 - Make sure motor is cold (20° - 25° C) and apply a Start command - Display will indicate CAL for about 40 seconds - Once the calibration is complete, the display will indicate StoP; apply another Start command to actually start the motor - If an attempt is made to start the drive in Vector or Enhanced V/Hz mode before performing the Motor Calibration, the drive will display F..n Id and will not operate • P300 = 2, 3: Same as above but only need to set P302...P304 				
P302 ⁽¹⁾	Motor Rated Voltage	0	{V}	600	<ul style="list-style-type: none"> • Default setting = drive rating • Set to motor nameplate data 	
P303 ⁽¹⁾	Motor Rated Current	0.0	{A}	500.0		
P304 ⁽¹⁾	Motor Rated Frequency	60	0	{Hz}	1000	Set to motor nameplate data
P305 ⁽¹⁾	Motor Rated Speed	1750	300	{RPM}	65000	
P306 ⁽¹⁾	Motor Cosine Phi	0.80	0.40		0.99	
		NOTE If motor cosine phi is not known, use one of the following formulas: $\cos \phi = \text{motor Watts} / (\text{motor efficiency} \times P302 \times P303 \times 1.732)$ $\cos \phi = \cos [\sin^{-1} (\text{magnetizing current} / \text{motor current})]$				
P310 ⁽¹⁾	Motor Stator Resistance	0.00	0.00	{ Ω }	64.00	<ul style="list-style-type: none"> • Will be automatically programmed by P399 • Changing these settings can adversely affect performance. Contact factory technical support prior to changing.
P311 ⁽¹⁾	Motor Stator Inductance	0.0	0.0	{mH}	2000	
P330	Torque Limit	100	0	{%}	400	When P300 = 5, sets the maximum output torque.

(1) Any changes to this parameter will not take effect until the drive is stopped



Commissioning

Code		Possible Settings				IMPORTANT
No.	Name	Default	Selection			
P331	Preset Torque Setpoint #1	100	0	{%}	400	TB-13A activated; P121 = 3 and P300 = 5
P332	Preset Torque Setpoint #2	100	0	{%}	400	TB-13B activated; P122 = 3 and P300 = 5
P333	Preset Torque Setpoint #3	100	0	{%}	400	TB-13C activated; P123 = 3 and P300 = 5
P340 ⁽¹⁾	Current Loop P Gain	0.25	0.00		16.0	Changing these settings can adversely affect performance. Contact factory technical support prior to changing.
P341 ⁽¹⁾	Current Loop I Gain	65	12	{ms}	9990	
P342 ⁽¹⁾	Speed Loop Adjustment	0.0	0.0	{%}	20.0	
P399	Motor Auto-calibration	0	0	Calibration Not Done		<ul style="list-style-type: none"> If P300 = 2...5, motor calibration must be performed, but motor data must be programmed first. An alternating CAL / Err will occur if: <ul style="list-style-type: none"> - motor calibration is attempted with P300 = 0 or 1 - motor calibration is attempted before programming motor data
			1	Calibration Enabled		
			2	Calibration Complete		
			<p>i NOTE To run the Auto Calibration:</p> <ul style="list-style-type: none"> - Set P302...P306 according to motor nameplate - Set P399 = 1 - Make sure motor is cold (20° - 25° C) - Apply a Start command - Display will indicate CAL for about 40 seconds - Once the calibration is complete, the display will indicate StoP; apply another Start command to actually start the motor - Parameter P399 will now be set to 2. 			

(1) Any changes to this parameter will not take effect until the drive is stopped

4.5.6 Network Parameters

Code		Possible Settings				IMPORTANT
No.	Name	Default	Selection			
P400	Network Protocol		0	Not Active		This parameter will only display the selection for the module that is installed.
			1	Remote Keypad		
			2	Modbus RTU		
			3	CANopen		
			4	DeviceNet		
			5	Ethernet		
P401 ... P499		Module Specific Parameters				Refer to the Reference Guide specific to the module installed.



4.5.7 Diagnostic Parameters

Code		Display Range (READ ONLY)		IMPORTANT	
No.	Name				
PS00	Fault History			<ul style="list-style-type: none"> Displays the last 8 faults Format: n.xxx where: n = 1..8; 1 is the newest fault xxx = fault message (without the F.) Refer to Section 5.3 	
PS01	Software version			Format: x.yz	
PS02	Drive ID			A flashing display indicates that the Drive ID stored in the EPM does not match the drive model it is plugged into.	
PS03	Internal Code			Alternating Display: xxx-; -yy	
PS05	DC Bus Voltage	0	{VDC}	1500	
PS06	Motor Voltage	0	{VAC}	1000	
PS07	Load	0	{%}	255	Motor load as % of drive's output current rating. Refer to Section 2.2.
PS08	Motor Current	0.0	{A}	1000	Actual motor current
PS09	Torque	0	{%}	500	Torque as % of motor rated torque (vector mode only)
PS10	kW	0.00	{kW}	650.0	
PS11	kWh	0.0	{kWh}	9999999	Alternating display: xxx-; yyyy when value exceeds 9999
PS12	Heatsink Temp	0	{°C}	150	Heatsink temperature
PS20	0-10 VDC Input	0.0	{VDC}	10.0	Actual value of signal at TB-5
PS21	4-20 mA Input	0.0	{mA}	20.0	Actual value of signal at TB-25
PS22	TB-5 Feedback	P204		P205	TB-5 signal value scaled to PID feedback units
PS23	TB-25 Feedback	P204		P205	TB-25 signal value scaled to PID feedback units
PS25	Analog Output	0	{VDC}	10.0	Refer to parameters P150...P155
PS27	Actual Output Frequency	0	{Hz}	500.0	
PS28	Network Speed Command	0	{Hz}	500.0	Command speed if (Auto: Network) is selected as the speed source
PS30	Terminal and Protection Status				Indicates terminal status using segments of the LED display. (Refer to Section 4.5.7.1)
PS31	Keypad Status				Indicates keypad button status using segments of the LED display. (Refer to Section 4.5.7.2)
PS40	Total Run Time	0	{h}	9999999	Alternating display: xxx-; yyyy when value exceeds 9999
PS41	Total Power On Time	0	{h}	9999999	



Commissioning

4.5.7.1 Terminal and Protection Status Display

Parameter P530 allows monitoring of the control terminal points and common drive conditions:

An illuminated LED segment indicates:

- the protective circuit is active (LED 1)
- the Logic Assertion Switch is set to High (+)
- input terminal is asserted (LED 2)
- output terminal is energized (LED 4)
- the Charge Relay is not a terminal, this segment will be illuminated when the Charge Relay is energized (LED 4).

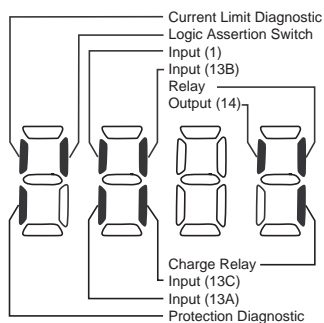

4.5.7.2 Keypad Status Display

Parameter P531 allows monitoring of the keypad pushbuttons:

An illuminated LED segment indicates when the button is depressed.

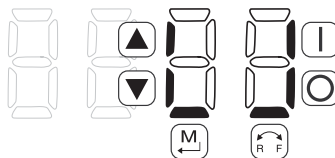



5 Troubleshooting and Diagnostics

5.1 Status/Warning Messages

	Status / Warning	Cause	Remedy
br	DC-injection brake active	DC-injection brake activated <ul style="list-style-type: none"> activation of digital input (P121...P123 = 18) automatically (P110 = 2, 4...6) automatically (P111 = 1, 3) 	Deactivate DC-injection brake <ul style="list-style-type: none"> deactivate digital input automatically after P175 time has expired
bF	Drive ID warning	The Drive ID (P502) stored on the EPM does not match the drive model.	<ul style="list-style-type: none"> Verify motor data (P302...P306) and perform Auto Calibration. Set drive mode (P300) to 0 or 1 Reset the drive (P199 to 3 or 4) and reprogram.
CR	Motor Auto-calibration is being performed	See P300, P399	
cE	An EPM that contains valid data from a previous software version has been installed	An attempt was made to change parameter settings	Parameter settings can only be changed after the EPM data is converted to the current version (P199 = 5)
CL	Current Limit (P171) reached	Motor overload	<ul style="list-style-type: none"> Increase P171 Verify drive/motor are proper size for application
dEC	Decel Override	The drive has stopped decelerating to avoid tripping into HF fault, due to excessive motor regen (2 sec max).	If drive trips into HF fault: <ul style="list-style-type: none"> Increase P105, P126 Install Dynamic Braking option
Err	Error	Invalid data was entered, or an invalid command was attempted	
FCL	Fast Current Limit	Overload	Verify drive/motor are proper size for application
FS	Flying Restart Attempt after Fault	P110 = 5,6	
GE	OEM Settings Operation warning	An attempt was made to change parameter settings while the drive is operating in OEM Settings mode (P199 = 1)	In OEM Settings mode, making changes to parameters is not permitted
GF	OEM Defaults data warning	An attempt was made to use (or reset to) the OEM default settings (P199 = 1 or 2) using an EPM without valid OEM data.	Install an EPM containing valid OEM Defaults data
LC	Fault Lockout	The drive attempted 5 restarts after a fault but all attempts were unsuccessful (P110 = 3...6)	<ul style="list-style-type: none"> Drive requires manual reset Check Fault History (P500) and correct fault condition
PdEC	PID Deceleration Status	PID setpoint has finished its ramp but the drive is still decelerating to a stop.	



Troubleshooting and Diagnostics

Status / Warning		Cause	Remedy
PI d	PID Mode Active	Drive has been put into PID Mode. Refer to parameter P200.	
5LP	Sleep Mode is active	Refer to parameters P240...P242	
5P	Start Pending	The drive has tripped into a fault and will automatically restart (P110 = 3...6)	To disable Auto-Restart, set P110 = 0...2
5Pd	PID Mode disabled.	Drive has been taken out of PID Mode. Refer to parameter P200.	
5toP	Output frequency = 0 Hz (outputs U, V, W inhibited)	Stop has been commanded from the keypad, terminal strip, or network	Apply Start command (Start Control source depends on P100)

5.2 Drive Configuration Messages

When the Mode button is pressed and held, the drive's display will provide a 4-digit code that indicates how the drive is configured. If the drive is in a Stop state when this is done, then the display will also indicate which control source commanded the drive to Stop (the two displays will alternate every second).

Configuration Display			
Format = x.y.zz	x = Control Source: L = Local Keypad t = Terminal Strip r = Remote Keypad n = Network	y = Mode: 5 = Speed mode P = PID mode t = Vector Torque mode	zz = Reference: CP = Keypad ▲ ▼ EU = 0-10 VDC (TB-5) El = 4-20 mA (TB-25) JG = Jog n = Network OP = MOP P 1...P7 = Preset 1...7
Example: <ul style="list-style-type: none"> L_5_CP = Local Keypad Start control, Speed mode, Keypad speed reference t_P_EU = Terminal Strip Start control, PID mode, 0-10 VDC setpoint reference n_t_P2 = Network Start control, Vector Torque mode, Preset Torque #2 reference 			
Stop Source Display			
Format = x_5tP	L_5tP = Stop command came from Local Keypad t_5tP = Stop command came from Terminal Strip r_5tP = Stop command came from Remote Keypad n_5tP = Stop command came from Network		

Troubleshooting and Diagnostics



5.3 Fault Messages

The messages below show how they will appear on the display when the drive trips. When looking at the Fault History (P500), the *F.* will not appear in the fault message.

Fault		Cause	Remedy ⁽¹⁾
<i>F_AF</i>	High Temperature fault	Drive is too hot inside	<ul style="list-style-type: none"> Reduce drive load Improve cooling
<i>F_AL</i>	Assertion Level fault	<ul style="list-style-type: none"> Assertion Level switch is changed during operation P120 is changed during operation P100 or P121...P123 are set to a value other than 0 and P120 does not match the Assertion Level Switch. 	<ul style="list-style-type: none"> Make sure the Assertion Level switch and P120 are both set for the type of input devices being used, prior to setting P100 or P121...P123. Refer to Section 3.2.3 and P120.
<i>F_bF</i>	Personality fault	Drive Hardware	<ul style="list-style-type: none"> Cycle Power
<i>F_CF</i>	Control fault	An EPM has been installed that is either blank or corrupted	<ul style="list-style-type: none"> Power down and install EPM with valid data
<i>F_cF</i>	Incompatible EPM fault	An EPM has been installed that contains data from an incompatible parameter version	<ul style="list-style-type: none"> Reset the drive back to defaults (P199 = 3, 4) and then re-program If problem persists, contact factory technical support
<i>F_dbF</i>	Dynamic Braking fault	Dynamic braking resistors are overheating	<ul style="list-style-type: none"> Increase active decel time (P105, P126, P127). Check mains voltage and P107
<i>F_EF</i>	External fault	<ul style="list-style-type: none"> P121...P123 = 21 and that digital input has been opened. P121...P123 = 22 and that digital input has been closed. 	<ul style="list-style-type: none"> Correct the external fault condition Make sure digital input is set properly for NC or NO circuit
<i>F_F I</i>	EPM fault	EPM missing or defective	Power down and replace EPM
<i>F_F2</i> ... <i>F_F i2</i>	Internal faults		Contact factory technical support
<i>F_Fnr</i>	Invalid message received	<ul style="list-style-type: none"> A network message was received while in Remote Keypad mode A remote keypad message was received while in Network mode 	Only the remote keypad or the network can be connected at one time; see P100
<i>F_FoL</i>	Loss of 4-20 mA signal fault	4-20 mA signal (at TB-25) is below 2 mA (P163 = 1)	Check signal/signal wire
<i>F_GF</i>	OEM Defaults data fault	Drive is powered up with P199 = 1 and OEM settings in the EPM are not valid.	Install an EPM containing valid OEM Defaults data or change P199 to 0.
<i>F_HF</i>	High DC Bus Voltage fault	Mains voltage is too high	Check mains voltage and P107
		Decel time is too short, or too much regen from motor	Increase active decel time (P105, P126, P127) or install Dynamic Braking option

(1) The drive can only be restarted if the error message has been reset



Troubleshooting and Diagnostics

Fault		Cause	Remedy ⁽¹⁾
F_IL	Digital Input Configuration fault (P121...P123)	More than one digital input set for the same function	Each setting can only be used once (except settings 0 and 3)
		Only one digital input configured for MOP function (Up, Down)	One input must be set to MOP Up, another must be set to MOP Down
		PID mode is entered with setpoint reference and feedback source set to the same analog signal	Change PID setpoint reference (P121...P123) or feedback source (P201).
		One of the digital inputs (P121...P123) is set to 10 and another is set to 11...14.	Reconfigure digital inputs
		One of the digital inputs (P121...P123) is set to 11 or 12 and another is set to 13 or 14.	
		PID enabled in Vector Torque mode (P200 = 1 or 2 and P300 = 5)	PID cannot be used in Vector Torque mode
F_UF	Remote keypad fault	Remote keypad disconnected	Check remote keypad connections
F_LF	Low DC Bus Voltage fault	Mains voltage too low	Check mains voltage
F_nId	No Motor ID fault	An attempt was made to start the drive in Vector or Enhanced V/Hz mode prior to performing the Motor Auto-calibration	See P300...P399 for Drive Mode setup and calibration.
F_nItF	Module communication fault	Communication failure between drive and Network Module.	Check module connections
F_nFI ... F_nFS	Network Faults	Refer to the module documentation, for Causes and Remedies.	
F_QF	Output fault: Transistor fault	Output short circuit	Check motor/motor cable
		Acceleration time too short	Increase P104, P125
		Severe motor overload, due to: <ul style="list-style-type: none"> • Mechanical problem • Drive/motor too small for application 	<ul style="list-style-type: none"> • Check machine / system • Verify drive/motor are proper size for application
		Boost values too high	Decrease P168, P169
		Excessive capacitive charging current from the motor cable	<ul style="list-style-type: none"> • Use shorter motor cables with lower charging current • Use low capacitance motor cables • Install reactor between motor and drive.
		Failed output transistor	Contact factory technical support
F_QFI	Output fault: Ground fault	Grounded motor phase	Check motor and motor cable
		Excessive capacitive charging current of the motor cable	Use shorter motor cables with lower charging current
F_PPF	Motor Overload fault	Excessive motor load for too long	<ul style="list-style-type: none"> • Verify proper setting of P108 • Verify drive and motor are proper size for application

(1) The drive can only be restarted if the error message has been reset

Troubleshooting and Diagnostics



Fault		Cause	Remedy ⁽¹⁾
F_rF	Flying Restart fault	Controller was unable to synchronize with the motor during restart attempt; (P110 = 5 or 6).	Check motor / load
F_5F	Single-Phase fault	A mains phase has been lost.	Check mains voltage
F_UF	Start fault	Start command was present when power was applied (P110 = 0 or 2).	<ul style="list-style-type: none"> • Must wait at least 2 seconds after power-up to apply Start command • Consider alternate starting method (Refer to parameter P110).

(1) The drive can only be restarted if the error message has been reset.

AC Technology Corporation

630 Douglas Street • Uxbridge, MA 01569 • USA

Sales: 800 217-9100 • Service: 508 278-9100

www.actech.com

(SV01D)