

Copyright © 2005 AC Technology Corporation

All rights reserved. No part of this manual may be reproduced or transmitted in any form without written permission from AC Technology Corporation. The information and technical data in this manual are subject to change without notice. AC Technology Corporation makes no warranty of any kind with respect to this material, including, but not limited to, the implied warranties of its merchantability and fitness for a given purpose. AC Technology Corporation assumes no responsibility for any errors that may appear in this manual.

All information given in this documentation has been carefully selected and tested for compliance with the hardware and software described. Nevertheless, discrepancies cannot be ruled out. We do not accept any responsibility nor liability for damages that may occur. Any necessary corrections will be implemented in subsequent editions.

This document printed in the United States

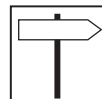

About these instructions	2
1 Safety information	3
1.1 <i>Pictographs used in these instructions</i>	4
2 Technical data	5
2.1 <i>Standards and application conditions</i>	5
2.2 <i>Ratings</i>	6
3 Installation	7
3.1 <i>Mechanical installation</i>	7
3.1.1 <i>Dimensions and mounting</i>	7
3.2 <i>Electrical installation</i>	8
3.2.1 <i>Installation according to EMC requirements</i>	8
3.2.2 <i>Fuses/cable cross-sections</i>	8
3.2.3 <i>Connection diagram</i>	9
3.2.4 <i>Control terminals</i>	10
4 Commissioning	11
4.1 <i>Parameter setting</i>	11
4.2 <i>Electronic programming module (EPM)</i>	11
4.3 <i>Parameter menu</i>	12
4.4 <i>CANopen mapping details</i>	22
4.4.1 <i>RPDO mapping details (h66 / h76)</i>	22
4.4.2 <i>TPDO mapping details (h86 / h96)</i>	25
4.5 <i>Quick CAN set-up</i>	29
5 Troubleshooting and fault elimination	30



About these instructions

This documentation applies to the smd frequency inverter, and contains important technical data and describes installation, operation, and commissioning.

These instructions are only valid for smd frequency inverters with software rev 20 (see drive nameplate).

Please read the instructions before commissioning.

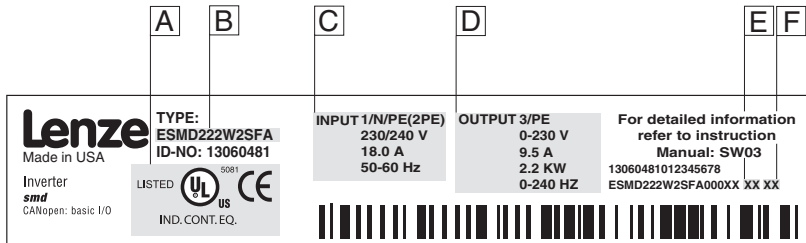

V0002

A Certifications

B Type

C Input Ratings

D Output Ratings

E Hardware Version

F Software Version

Scope of delivery	Important
<ul style="list-style-type: none"> 1 smd inverter (ESMD...) with EPM installed (see Section 4.2) 1 Operating Instructions 	<p>After receipt of the delivery, check immediately whether the items delivered match the accompanying papers. Lenze does not accept any liability for deficiencies claimed subsequently.</p> <p>Claim</p> <ul style="list-style-type: none"> visible transport damage immediately to the forwarder. visible deficiencies/incompleteness immediately to your Lenze representative.



1 Safety information

General

Some parts of Lenze controllers (frequency inverters, servo inverters, DC controllers) can be live, moving and rotating. Some surfaces can be hot.

Non-authorized removal of the required cover, inappropriate use, and incorrect installation or operation creates the risk of severe injury to personnel or damage to equipment.

All operations concerning transport, installation, and commissioning as well as maintenance must be carried out by qualified, skilled personnel (IEC 364 and CENELEC HD 384 or DIN VDE 0100 and IEC report 664 or DIN VDE0110 and national regulations for the prevention of accidents must be observed).

According to this basic safety information, qualified skilled personnel are persons who are familiar with the installation, assembly, commissioning, and operation of the product and who have the qualifications necessary for their occupation.

Application as directed

Drive controllers are components which are designed for installation in electrical systems or machinery. They are not to be used as appliances. They are intended exclusively for professional and commercial purposes according to EN 61000-3-2. The documentation includes information on compliance with the EN 61000-3-2.

When installing the drive controllers in machines, commissioning (i.e. the starting of operation as directed) is prohibited until it is proven that the machine complies with the regulations of the EC Directive 98/37/EC (Machinery Directive); EN 60204 must be observed.

Commissioning (i.e. starting of operation as directed) is only allowed when there is compliance with the EMC Directive (89/336/EEC).

The drive controllers meet the requirements of the Low Voltage Directive 73/23/EEC. The harmonised standards of the series EN 50178/DIN VDE 0160 apply to the controllers.

Note: The availability of controllers is restricted according to EN 61800-3. These products can cause radio interference in residential areas. In this case, special measures can be necessary.

Installation

Ensure proper handling and avoid excessive mechanical stress. Do not bend any components and do not change any insulation distances during transport or handling. Do not touch any electronic components and contacts.

Controllers contain electrostatically sensitive components, which can easily be damaged by inappropriate handling. Do not damage or destroy any electrical components since this might endanger your health!

Electrical connection

When working on live drive controllers, applicable national regulations for the prevention of accidents (e.g. VBG 4) must be observed.

The electrical installation must be carried out according to the appropriate regulations (e.g. cable cross-sections, fuses, PE connection). Additional information can be obtained from the documentation.

The documentation contains information about installation in compliance with EMC (shielding, grounding, filters and cables). These notes must also be observed for CE-marked controllers.

The manufacturer of the system or machine is responsible for compliance with the required limit values demanded by EMC legislation.



Safety information

Operation

Systems including controllers must be equipped with additional monitoring and protection devices according to the corresponding standards (e.g. technical equipment, regulations for prevention of accidents, etc.). You are allowed to adapt the controller to your application as described in the documentation.



DANGER!

- After the controller has been disconnected from the supply voltage, live components and power connection must not be touched immediately, since capacitors could be charged. Please observe the corresponding notes on the controller.
- Do not continuously cycle input power to the controller more than once every three minutes.
- Please close all protective covers and doors during operation.

Note for UL approved system with integrated controllers

UL warnings are notes which apply to UL systems. The documentation contains special information about UL.



Warnings!

- Suitable for use on a circuit capable of delivering not more than 5000 rms symmetrical amperes, 240 V maximum (240 V devices) or 500 V maximum (400/500 V devices) respectively
- Use minimum 75 °C copper wire only.
- Shall be installed in a pollution degree 2 macro-environment.

1.1 Pictographs used in these instructions

Pictograph	Signal word	Meaning	Consequences if ignored
	DANGER!	Warning of Hazardous Electrical Voltage.	Reference to an imminent danger that may result in death or serious personal injury if the corresponding measures are not taken.
	WARNING!	Impending or possible danger for persons	Death or injury
	STOP!	Possible damage to equipment	Damage to drive system or its surroundings
	Note	Useful tip: If observed, it will make using the drive easier	



2 Technical data

2.1 Standards and application conditions

Conformity	CE	Low Voltage Directive (73/23/EEC)
Approvals	UL 508C	Underwriters Laboratories - Power Conversion Equipment
Max. permissible motor cable length ⁽¹⁾	shielded:	50 m (low-capacitance)
	unshielded:	100 m
Input voltage phase imbalance	≤ 2%	
Humidity	≤ 95% non-condensing	
Output frequency	0...240 Hz	
Environmental conditions	Class 3K3 to EN 50178	
Temperature range	Transport	-25 ... +70 °C
	Storage	-20 ... +70 °C
	Operation	0 ... +55 °C (with 2.5 %/°C current derating above +40 °C)
Installation height	0 ... 4000 m a.m.s.l. (with 5 %/1000 m current derating above 1000 m a.m.s.l.)	
Vibration resistance	acceleration resistant up to 0.7 g 10... 150Hz	
⚠ Earth leakage current	> 3.5 mA to PE	
Enclosure (EN 60529)	IP 20	
Protection measures against	short circuit, earth fault, overvoltage, motor stalling, motor overload	
Operation in public supply networks (Limitation of harmonic currents according to EN 61000-3-2)	Total power connected to the mains	Compliance with the requirements ⁽²⁾
	< 0.5 kW	With mains choke
	0.5 ... 1 kW	With active filter (in preparation)
	> 1 kW	Without additional measures

(1) For compliance with EMC regulations, the permissible cable lengths may change.

(2) The additional measures described only ensure that the controllers meet the requirements of the EN 61000-3-2. The machine/system manufacturer is responsible for the compliance with the regulations of the machine!



Technical data

2.2 Ratings

Type	Power [kW]	Mains		Output Current			
		Voltage, frequency	Current [A]	I_r		I_{max} for 60 s	
				[A] ⁽¹⁾	[A] ⁽²⁾	[A] ⁽¹⁾	[A] ⁽²⁾
ESMD251W2SFA	0.25	1/N/PE 230/240 V 2/PE 230/240 V (180 V - 0% ... 264 V + 0 %) 50/60 Hz (48 Hz - 0 % ... 62 Hz + 0 %)	3.4	1.7	1.6	2.6	2.4
ESMD371W2SFA	0.37		5.0	2.4	2.2	3.6	3.3
ESMD551W2SFA	0.55		6.0	3.0	2.8	4.5	4.2
ESMD751W2SFA	0.75		9.0	4.0	3.7	6.0	5.5
ESMD152W2SFA	1.5		14.0	7.0	6.4	10.5	9.6
ESMD222W2SFA	2.2		21.0	9.5	8.7	14.3	13.1
ESMD371W2TXA	0.37		2.7	2.4	2.2	3.6	3.3
ESMD751W2TXA	0.75		5.1	4.2	3.9	6.3	5.9
ESMD112W2TXA	1.1		6.9	6.0	5.5	9.0	8.3
ESMD152W2TXA	1.5		7.9	7.0	6.4	10.5	9.6
ESMD222W2TXA	2.2	11.0	9.6	8.8	14.4	13.2	
ESMD302W2TXA	3.0	13.5	12.0	11.0	18.0	16.5	
ESMD402W2TXA	4.0	17.1	15.2	14.0	22.8	21.0	

(1) For rated mains voltage and carrier frequencies 4, 6, 8 kHz

(2) For rated mains voltage and carrier frequency 10 kHz

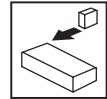

3 Installation

3.1 Mechanical installation

3.1.1 Dimensions and mounting

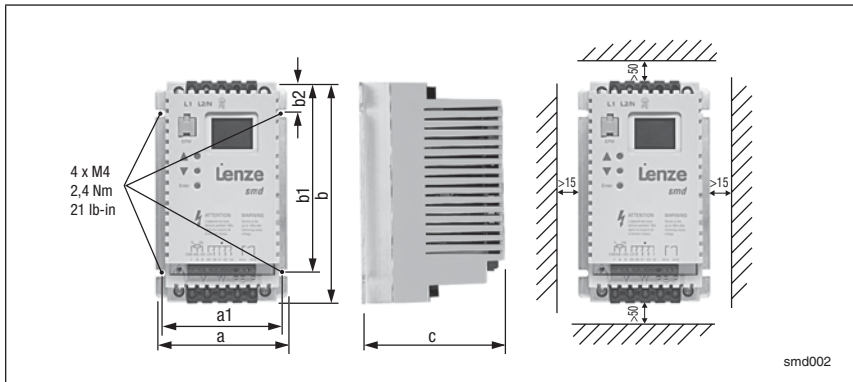

Type	a [mm]	a1 [mm]	b [mm]	b1 [mm]	b2 [mm]	c [mm]	m [kg]
ESMD251W2SFA	93	84	146	128	17	83	0.5
ESMD371W2SFA							
ESMD551W2SFA							
ESMD751W2SFA	93	84	146	128	17	92	0.6
ESMD152W2SFA	114	105	146	128	17	124	1.2
ESMD222W2SFA	114	105	146	128	17	140	1.4
ESMD371W2TXA	93	84	146	128	17	83	0.5
ESMD751W2TXA	93	84	146	128	17	92	0.6
ESMD112W2TXA	93	84	146	128	17	141	1.2
ESMD152W2TXA							
ESMD222W2TXA	114	105	146	128	17	140	1.4
ESMD302W2TXA	114	105	146	128	17	171	1.9
ESMD402W2TXA	114	105	146	100	17	171	1.7



WARNING!

Drives must not be installed where subjected to adverse environmental conditions such as: combustible, oily, or hazardous vapors or dust; excessive moisture; excessive vibration or excessive temperatures. Contact Lenze for more information.



Installation

3.2 Electrical installation

3.2.1 Installation according to EMC requirements

<p>EMC Compliance with EN 61800-3/A11</p>	
<p>Noise emission Compliance with limit value class A according to EN 55011 if installed in a control cabinet with the appropriate footprint filter and the motor cable length does not exceed 10m</p>	
<p>A Screen clamps B Control cable C Low-capacitance motor cable (core/core ≤ 75 pF/m, core/screen ≤ 150 pF/m) D Electrically conductive mounting plate E Filter (if required)</p>	
Tmd005	

3.2.2 Fuses/cable cross-sections⁽¹⁾

Type	Installation to EN 60204-1			Installation to UL		E.I.c.b. ⁽²⁾
	Fuse	Miniature circuit breaker	L1, L2/N, L3, PE [mm ²]	Fuse ⁽³⁾	L1, L2/N, L3, PE [AWG]	
ESMD251W2SFA ... ESMD551W2SFA ESMD371W2TXA ... ESMD112W2TXA	M10 A	C10 A	1.5	10 A	14	≥ 30 mA
ESMD152W2TXA	M12 A	C12 A	1.5	12 A	14	
ESMD751W2SFA, ESMD222W2TXA	M16 A	C16 A	2.5	15 A	14	
ESMD152W2SFA, ESMD302W2TXA	M20 A	C20 A	2.5	20 A	12	
ESMD222W2SFA, ESMD402W2TXA	M25 A	C25 A	4 ⁽⁴⁾	25 A	10	

(1) Observe the applicable local regulations

(2) Pulse-current or universal-current sensitive earth leakage circuit breaker

(3) UL Class CC or T fast-acting current-limiting type fuses, 200,000 AIC, required. Bussman KTK-R, JIN, JJS or equivalent

(4) Connection without end ferrules or with attached pin end connectors

Observe the following when using E.I.c.b:

- Installation of E.I.c.b only between supplying mains and controller.
- The E.I.c.b can be activated by:
 - capacitive leakage currents between the cable screens during operation (especially with long, screened motor cables)
 - connecting several controllers to the mains at the same time
 - RFI filters

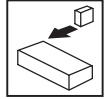

3.2.3 Connection diagram

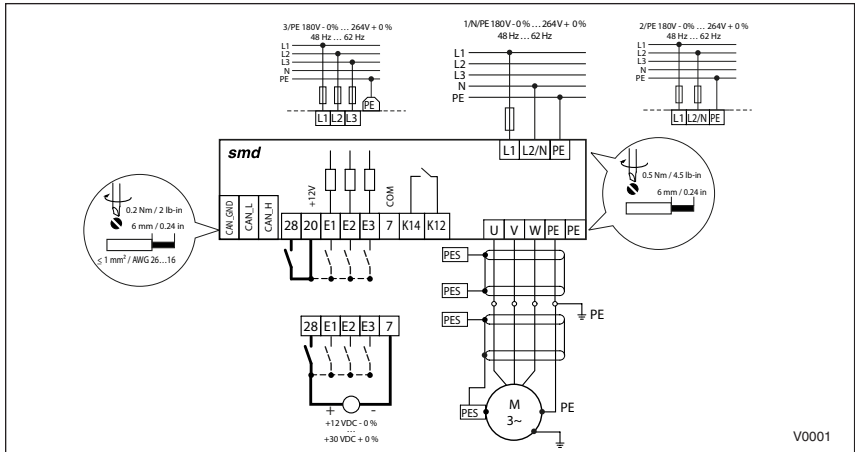

Danger!

- Hazard of electrical shock! Circuit potentials are up to 240 VAC above earth ground. Capacitors retain charge after power is removed. Disconnect power and wait until the voltage between B+ and B- is 0 VDC before servicing the drive.
- Do not connect mains power to the output terminals (U,V,W)! Severe damage to the drive will result.
- Do not cycle mains power more than once every three minutes. Damage to the drive will result.



Installation

3.2.4 Control terminals

Terminal	Data for control connections (printed in bold = Lenze setting)		
CAN_GND	CAN earth ground	For reliable communication make sure terminal CAN_GND is connected to CAN network GND/common. If only two wires are used (CAN_H and CAN_L) in the network, connect CAN_GND to chassis/earth ground.	
CAN_L	CAN low	If controller is located at either end of the network, a terminating resistor (120Ω typical) should be connected across CAN_L and CAN_H	
CAN_H	CAN high		
28	Digital input Start/Stop	LOW = Stop (OFF) HIGH = Run Enable	R _i = 3.3 kΩ
20	Internal DC supply for digital inputs	+12 V, max. 20 mA	
E1	Digital input configurable with CE1 Activate fixed setpoint 1 (JOG1)	HIGH = JOG1 active	R _i = 3.3 kΩ
E2	Digital input configurable with CE2 Direction of rotation	LOW = CW rotation HIGH = CCW rotation	
E3	Digital input/output configurable with CE3 Activate DC injection brake (DCB)	HIGH = DCB active	
7	Reference potential		
K12	Relay output (normally-open contact) configurable with C08	AC 250 V / 3 A DC 24 V / 2 A ... 240 V / 0.22 A	
K14	Fault (TRIP)		

LOW = 0 ... +3 V, HIGH = +12 ... +30 V

Protection against contact

- All terminals have a basic isolation (single insulating distance)
- Protection against contact can only be ensured by additional measures i.e. double insulation



4 Commissioning

4.1 Parameter setting

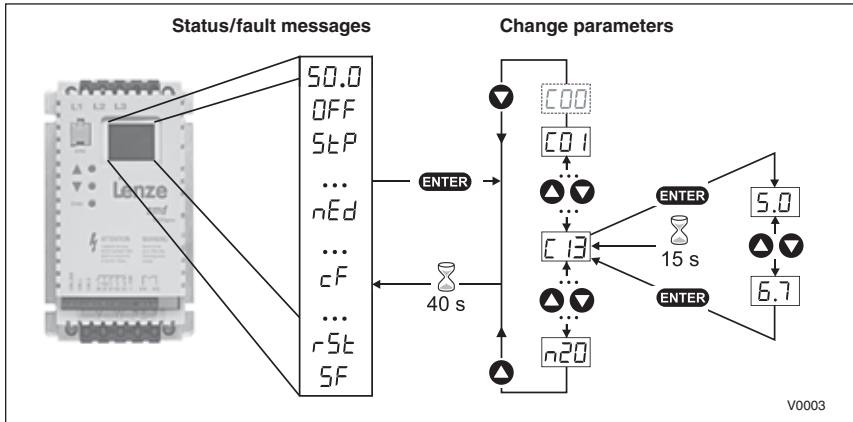

NOTE

If the password function is enabled, the password must be entered into C00 to access the parameters. C00 will not appear unless the password function is enabled. See C94.

4.2 Electronic programming module (EPM)

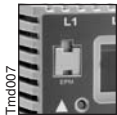



The EPM contains the controller's memory. Whenever parameter settings are changed, the values are stored in the EPM. It can be removed, but must be installed for the controller to operate (a missing EPM will trigger an **F I** fault). The controller ships with protective tape over the EPM that can be removed after installation.

An optional EPM Programmer (EEP1RA) is available that allows: the controller to be programmed without power; OEM settings to be default settings; fast copying of EPMs when multiple controllers require identical settings. It can also store up to 60 custom parameter files for even faster controller programming.



Commissioning

4.3 Parameter menu

Code		Possible Settings		IMPORTANT
No.	Name	Lenze	Selection	
C00	Password entry	0	0 999	Visible only when password is active (see C94)
C01	Setpoint source	0	Setpoint source: 0,1 Code c40	Control configuration: Control = terminals Programming = keypad/limited CANopen Monitoring = CANopen Note: RPDOs not processed in these modes
			2 CANopen	Control = terminals Programming = CANopen / keypad Monitoring = CANopen Note: Only frequency setpoint part of RPDOs are processed in this mode
			3 CANopen	Control = CANopen Programming = CANopen / keypad Monitoring = CANopen
C02	Load Lenze setting		0 No action/loading complete	<ul style="list-style-type: none"> • C02 = 1... 4 only possible with OFF • C02 = 2 : C11, C15 = 60.0 Hz, C87 = 1740 RPM, and C89 = 60 Hz
			1 Load 50 Hz Lenze settings	
			2 Load 60 Hz Lenze settings	
			3 Load OEM settings	
			4 Translate	
	WARNING! C02 = 1... 3 overwrites all settings! TRIP circuitry may be disabled! Check codes CE1...CE3.			
	NOTE If an EPM that contains compatible data from a previous software version is installed, C02 = 4 converts the data to the current version.			

Commissioning



Code		Possible Settings		IMPORTANT	
No.	Name	Lenze	Selection		
CE1	Configuration - Digital input E1	1	1 Activate fixed setpoint 1 (JOG1)	<ul style="list-style-type: none"> • Use C37...C39 to adjust fixed setpoints • Activate JOG3: Both terminals = HIGH 	
			2 Activate fixed setpoint 2 (JOG2)		
			3 DC braking (DCB)	See also C36	
			4 Direction of rotation	LOW = CW rotation HIGH = CCW rotation	
			5 Quick stop	Controlled deceleration to standstill, active LOW; Set decel rate in C13	
			6 CW rotation	CW rotation = LOW and CCW rotation =	
CE2	Configuration - Digital input E2	4	7 CCW rotation	LOW: Quick stop; Open-circuit protected	
			8 UP (setpoint ramp-up)	UP = LOW and DOWN = LOW: Quick stop; Use momentary NC contacts	
			9 DOWN (setpoint ramp-down)		
			10 TRIP set	Active LOW, triggers EEr (motor coasts to standstill) NOTE: NC thermal contact from the motor can be used to trigger this input	
			11 TRIP reset	See also c70	
			12 No action	can be used if Ex inputs are used only as CANopen digital inputs	
CE3	Configuration - Digital input/output E3	3	1...11 (same as above)	<ul style="list-style-type: none"> • 1...11 configures term. E3 as an input • 20...30 configures term. E3 as a current-sourcing (PNP) output rated 12 VDC / 50 mA 	
			13...19 (reserved)		
			20 Ready		
			21 Fault		
			22 Motor is running		
			23 Motor is running - CW rotation		
			24 Motor is running - CCW rotation		
			25 Output frequency = 0 Hz		
			26 Frequency setpoint reached		
			27 Threshold (C17) exceeded		
			28 Current limit reached		• in either motor or generator mode
			29 No action		• Output disabled
			30 CANopen Control		• output controlled by RPDO (h66,h76 = 4)
 Note	<p>A CFG fault will occur under the following conditions:</p> <ul style="list-style-type: none"> • E1...E3 settings are duplicated (each setting can only be used once) • One input is set to UP and another is not set to DOWN, or vice-versa 				
COB	Configuration - Relay output (terminals K14 and K12)	1	Relay is energized if		
			0 Ready		
			1 Fault		
			2 Motor is running		
			3 Motor is running - CW rotation		
			4 Motor is running - CCW rotation		
5 Output frequency = 0 Hz					
6 Frequency setpoint reached					
7 Threshold (C17) exceeded					
8 Current limit reached	in either motor or generator mode				
9 CANopen Control	Output controlled by RPDO (h66,h76 = 4)				



Commissioning

Code		Possible Settings				IMPORTANT
No.	Name	Lenze	Selection			
C10	Minimum output frequency	0.0	0.0	{Hz}	240	C10 not active for fixed setpoints or setpoint selection via c40
C11	Maximum output frequency	50.0	7.5	{Hz}	240	C11 is never exceeded
C12	Acceleration time	5.0	0.0	{s}	999	<ul style="list-style-type: none"> C12 = frequency change 0 Hz...C11 C13 = frequency change C11...0 Hz
C13	Deceleration time	5.0	0.0	{s}	999	
C14	Operating Mode	2	0	Linear characteristic with Auto-Boost	<ul style="list-style-type: none"> Linear characteristic: for standard applications Square-law characteristic: for fans and pumps with square-law load characteristic Auto boost: load-dependent output voltage for low-loss operation 	
			1	Square-law characteristic with Auto-Boost		
			2	Linear characteristic with constant V_{min} boost		
			3	Square-law characteristic with constant V_{min} boost		
C15	V/f reference point	50.0	25.0	{Hz}	999	<p style="text-align: right;">smd006</p>
C16	V_{min} boost (optimization of torque behavior)	6.0	0.0	{%}	40.0	
			Set the rated motor frequency (nameplate) for standard applications			
			Set after commissioning: The unloaded motor should run at slip frequency (approx. 5 Hz), increase C16 until motor current (C54) = 0.8 x rated motor current			
C17	Frequency threshold (Q_{min})	0.0	0.0	{Hz}	240	See C08, selection 7 Reference: setpoint
C18	Chopper frequency	2	0	4 kHz	<ul style="list-style-type: none"> As chopper frequency is increased, motor noise is decreased Observe derating in Section 2.2 Automatic derating to 4 kHz at $1.2 \times I_r$ 	
			1	6 kHz		
			2	8 kHz		
			3	10 kHz		
C21	Slip compensation	0.0	0.0	{%}	40.0	Change C21 until the motor speed no longer changes between no load and maximum load
C22	Current limit	150	30	{%}	150	<ul style="list-style-type: none"> When the limit value is reached, either the acceleration time increases or the output frequency decreases
			Reference: smd rated output current			
C24	Accel boost	0.0	0.0	{%}	20.0	Accel boost is only active during acceleration
C36	Voltage - DC injection brake (DCB)	4.0	0.0	{%}	50.0	<ul style="list-style-type: none"> See CE1...CE3 and c06 Confirm motor suitability for use with DC braking

Commissioning



Code		Possible Settings				IMPORTANT
No.	Name	Lenze	Selection			
C37	Fixed setpoint 1 (JOG 1)	20.0	0.0	{Hz}	240	
C38	Fixed setpoint 2 (JOG 2)	30.0	0.0	{Hz}	240	
C39	Fixed setpoint 3 (JOG 3)	40.0	0.0	{Hz}	240	
C46	Frequency setpoint		0.0	{Hz}	240	Display: Setpoint via CANopen or function UP/DOWN
C50	Output frequency		0.0	{Hz}	240	Display
C53	DC bus voltage		0.0	{%}	255	Display
C54	Motor current		0.0	{%}	255	Display
C87	Motor rated speed	1390	300	{RPM}	65000	Set to motor nameplate speed
C89	Motor rated frequency	50	10	{Hz}	1000	Set to motor nameplate frequency
C94	User password	0	0		999	When set to a value other than 0, must enter password at C00 to access parameters
			Changing from "0" (no password), value will start at 763			
C99	Software version					Display, format: x.yz
c06	Holding time - automatic DC injection brake (Auto-DCB)	0.0	0.0	{s}	999	<ul style="list-style-type: none"> Automatic motor braking below 0.1 Hz by means of motor DC current for the entire holding time (afterwards: U, V, W inhibited) Confirm motor suitability for use with DC braking
c20	I ² t switch-off (thermal motor monitoring)	100	30	{%}	100	<ul style="list-style-type: none"> Triggers DC6 fault when motor current exceeds c20 for too long Correct setting = (motor nameplate current) / (<i>smd</i> output current rating) X 100% Example: motor = 6.4 amps and <i>smd</i> = 7.0 amps; correct setting = 91% (6.4 / 7.0 = 0.91 x 100% = 91%)
			<p>i Note Do not set above the rated motor current as listed on the motor dataplate. The motor thermal overload function is UL approved as a motor protection device. If line power is cycled, the motor thermal state is reset to cold state. Cycling power after an overload fault may result in reducing the motor life.</p>			
c40	Frequency setpoint via keys	0.0	0.0	{Hz}	240	Only active if C01 = 0, 1
c42	Start condition (with mains on)	1	0	Start after LOW-HIGH change at terminal 28		See also c70
			1	Auto start if terminal 28 = HIGH		
			<p>! WARNING! Automatic starting/restarting may cause damage to equipment and/or injury to personnel! Automatic starting/restarting should only be used on equipment that is inaccessible to personnel.</p>			



Commissioning

Code		Possible Settings			IMPORTANT	
No.	Name	Lenze	Selection			
c60	Mode selection for c61	0	0 Monitoring only		c60 = 1 allows the keys to adjust speed setpoint (c40) while monitoring c61	
			1 Monitoring and editing			
c61	Present status/error		status/error message		<ul style="list-style-type: none"> • Display • Refer to Section 5 for explanation of status and error messages 	
c62	Last error		error message			
c63	Last error but one					
c70	Configuration TRIP reset (error reset)	0	0 TRIP reset after LOW-HIGH change at terminal 28, mains switching, or after LOW-HIGH change at digital input "TRIP reset"		<ul style="list-style-type: none"> • Auto-TRIP reset after the time set in c71 • More than 8 errors in 10 minutes will trigger r5t fault 	
				1 Auto-TRIP reset		
WARNING! Automatic starting/restarting may cause damage to equipment and/or injury to personnel! Automatic starting/restarting should only be used on equipment that is inaccessible to personnel.						
c71	Auto-TRIP reset delay	0.0	0.0 {s}	60.0	See c70	
c78	Operating time counter		Display Total time in status "Start"		0...999 h: format xxx 1000...9999 h: format x.xx (x1000) 10000...99999 h: format xx.x (x1000)	
c79	Mains connection time counter		Display Total time of mains = on			
CANopen / System bus parameters						
h42	Guard time	0	0 {ms}	65535	<ul style="list-style-type: none"> • h42 x h43 = node life time • If RTR frame with ID = 0x700 + Node ID (h50) is not received during the node life time, the controller will react according to h44 • If heart beat message is enabled, the guard function is disabled • h44 is only active when C01 = 3 and h42 x h43 > 0 	
h43	Life time factor	0	0	255		
h44	Guard time event reaction	0	0 Not active			
			1 Inhibit			
			2 Quick stop			
			3 Trip fault FC3			
h45	Error behavior	1	0 transition to pre-operational (only if current state is operational)		Specifies action taken by the drive when it encounters a communication error (ex. Node guarding event or Bus Off)	
			1 No state change			
			2 transition to stopped			
h46	Message monitoring time	0	0 {ms}	65535	<ul style="list-style-type: none"> • h46 and h47 can be used to monitor all valid messages (e.g. SDO, SYNC, PDO...). • h46 = 0 or h47 = 0 disables message monitoring function • h47 is only active when C01 = 3 	
h47	Message monitoring time out reaction	0	0 Not active			
				1 Inhibit		
				2 Quick stop		
				3 Trip fault FC3		

Commissioning



Code		Possible Settings		IMPORTANT
No.	Name	Lenze	Selection	
h48	Monitoring timeout status		Bits: 0 Guard time timeout 1 No valid message received 2 RPD01 timeout 3 RPD02 timeout 4 CAN initialization fault 5 6 Receive buffers overflow 7	<ul style="list-style-type: none"> Read-only Indicates cause of $F[\overline{C}]$ fault, inhibit, or quick stop (depending on the settings of h44, h47, h65, h75) Bits 5...7 create a binary number from 0 to 7 indicating the number of overflows in the receive buffers (h49 bits 6 and 7)
h49	CAN controller status value (8-bit value)		Bits: 0 Receive/transmit error warning flag (96 or more errors) 1 Receive error warning flag (96 or more receive errors) 2 Transmit error warning flag (96 or more transmit errors) 3 Receive error passive flag (128 or more receive errors) 4 Transmit error passive flag (128 or more transmit errors) 5 Bus-off error flag 6 Receive buffer 0 overflow flag 7 Receive buffer 1 overflow flag	<ul style="list-style-type: none"> Read-only CAN warnings and errors
h50⁽¹⁾	CAN address (Node ID)	1	127	If h53 = 0, 1: maximum setting = 63
h5⁽¹⁾	CAN baud rate	5	0 10 kbps (max distance = 5000m) 1 20 kbps (max distance = 2500m) 2 50 kbps (max distance = 1000m) 3 125 kbps (max distance = 500m) 4 250 kbps (max distance = 250m) 5 500 kbps (max distance = 100m)	
h52⁽¹⁾	System bus participant	0	0 Slave 1 Slave with autostart enabled 0x1F80 NMT bootup - bit 2 2 System bus master (not NMT master)	<ul style="list-style-type: none"> h52 = 1: Controller enters operational state automatically h52 = 2: Controller sends "NMT start all nodes" after boot-up time (h55) and enters operational state

⁽¹⁾ These parameters take effect only after power-up, h58 reset, "NMT reset node", or "NMT reset communication services"



Commissioning

Code		Possible Settings			IMPORTANT
No.	Name	Lenze	Selection		
h53 ⁽¹⁾	Parameter channel 2 (SDO#2)	0	0 Enable: Node ID range (1...63) with default COB ID for SYNC, RPDO, and TPDO 1 Enable: Node ID range (1...63) with programmable COB ID using h54, h60, h70, h80, h90 2 Disable: Node ID range (1...127) with default COB ID for SYNC, RPDO, and TPDO 3 Disable: Node ID range (1...127) with programmable COB ID using h54, h60, h70, h80, h90		<ul style="list-style-type: none"> h53 = 0, 1: CAN address 1...63; 64...127 used for SDO2 SDO#1 COB ID = 1536 + Node ID SDO#2 COB ID = 1600 + Node ID (if enabled)
h54 ⁽¹⁾	SYNC COB ID	128	0	2047	Note: Controller does not generate SYNC object
h55 ⁽¹⁾	Boot up time	3000	0	{ms} 65535	Controller sends "NMT start all nodes" message after this delay (active only when h52 = 2)
h56	Heartbeat time	2000	0	{ms} 65535	<ul style="list-style-type: none"> Producer heartbeat time h56 = 0 disables heartbeat transmission
h58	Reset CAN node	0	0 No action 1 Reset CAN communication		On transition from 0 to 1, re-initializes CAN controller and activates changes made to parameters marked with ⁽¹⁾
 WARNING! CAN re-initialization may activate new RPDO configurations, which can result in changes to present controller state, including starting.					
h59	CANopen status		0 Not initialized 1 Initializing 2 Stopped 3 Pre-operational 4 reserved 5 Operational		<ul style="list-style-type: none"> Read-only Note: RPDOs and TPDOs are only active in operational state (h59 = 5)
RPDO#1 configuration parameters					
h60 ⁽¹⁾	RPDO#1 COB ID	513	0	2047	If h53 = 0, 2: Setting will change to 512 + Node ID during power-up or h58 reset.
h61 ⁽¹⁾	RPDO#1 enable/disable	1	0 Disable 1 Enable		
h62	RPDO#1 transmission type	255	0	255	<ul style="list-style-type: none"> h62 = 0...240: transfer on every SYNC received. h62 = 254, 255: immediate transfer
h64	RPDO#1 event monitoring timer	0	0	{ms} 65535	h64 = 0: monitoring disabled

⁽¹⁾ These parameters take effect only after power-up, h58 reset, "NMT reset node", or "NMT reset communication services"

Commissioning



Code		Possible Settings		IMPORTANT
No.	Name	Lenze	Selection	
h65	RPDO#1 time out reaction	0	0 Not active 1 Inhibit 2 Quick stop 3 Trip fault $FE3$	Only active when C01 = 3
h66⁽¹⁾	RPDO#1 mapping (see RPDO mapping details)	0	0 C0135 control word + C46 signed 1 C0135 control word + C46 unsigned 2 402 Drives and Motion Control: PDO Controlword 0x6040 3 402 Drives and Motion Control: PDO Controlword 0x6040 + vl target velocity 0x6042 4 C0135 Controlword + C46 signed and scaled + Digital output	C46 scaling: $\pm 50 = \pm 1.0$ Hz C46 scaling: 10 = 1.0 Hz • vl target velocity units = signed RPM • RPM calculation based on C87 and C89 C46 scaling: $\pm 16384 = C11$
h69	RPDO#1 status		0 255	• Read-only • Number of received RPDO#1 messages • Above 255, starts over at 0
RPDO#2 configuration parameters				
h70⁽¹⁾	RPDO#2 COB ID	769	0 2047	If h53 = 0, 2: Setting will change to 768 + Node ID during power-up or h58 reset.
h71⁽¹⁾	RPDO#2 enable/disable	0	0 Disable 1 Enable	
h72	RPDO#2 transmission type	255	0 255	• h72 = 0...240: transfer on every SYNC received • h72 = 254, 255: immediate transfer
h74	RPDO#2 event monitoring timer	0	0 {ms} 65535	h74 = 0: monitoring disabled
h75	RPDO#2 time out reaction	0	0 Not active 1 Inhibit 2 Quick stop 3 Trip fault $FE3$	Only active when C01 = 3
h76⁽¹⁾	RPDO#2 mapping (see RPDO mapping details)	0	0 C0135 control word + C46 signed 1 C0135 control word + C46 unsigned 2 402 Drives and Motion Control: PDO Controlword 0x6040 3 402 Drives and Motion Control: PDO Controlword 0x6040 + vl target velocity 0x6042 4 C0135 Controlword + C46 signed and scaled + Digital output	C46 scaling: $\pm 50 = \pm 1.0$ Hz C46 scaling: 10 = 1.0 Hz • vl target velocity units = signed RPM • RPM calculation based on C87 and C89 C46 scaling: $\pm 16384 = C11$

⁽¹⁾ These parameters take effect only after power-up, h58 reset, "NMT reset node", or "NMT reset communication services"



Commissioning

Code		Possible Settings		IMPORTANT		
No.	Name	Lenze	Selection			
h79	RPDO#2 status		0	255	<ul style="list-style-type: none"> Read-only Number of received RPDO#2 messages Above 255, starts over at 0 	
TPDO#1 configuration parameters						
h80⁽¹⁾	TPDO#1 COB ID	385	0	2047	If h53 = 0, 2: Setting will change to 384 + Node ID during power-up or h58 reset.	
h88⁽¹⁾	TPDO#1 enable/disable	1	0	Disable		
			1	Enable (no RTR)		
			2	Enable (with RTR)	Enable individual polling of TPDO#1	
h82	TPDO#1 transmission type	255	0	255	<ul style="list-style-type: none"> h82 = 0...240: Transmit TPDO#1 after every nth SYNC received + Event + RTR (if enabled) h82 = 253: Event + RTR (if enabled) h82 = 254: COS triggered (WORD0 of TPDO#1) + Event + RTR (if enabled) h82 = 255: Event + RTR (if enabled) 	
h83⁽¹⁾	TPDO#1 inhibit time	50	0	{0.1 ms}	65535	Sets minimum time between TPDO#1 transmissions (h83 = 50 = 5.0 ms)
h84	TPDO#1 event timer	0	0	{ms}	65535	<ul style="list-style-type: none"> Sets the fixed interval for TPDO#1 transmission h84 = 0: disables event timer
h86⁽¹⁾	TPDO#1 mapping (see TPDO mapping details)	0	0	C0150 + C50 signed	C50 scaling: $\pm 50 = \pm 1.0$ Hz	
			1	C0150 + C50 unsigned	C50 scaling: 10 = 1.0 Hz	
			2	Controller status in C0135 format + frequency setpoint signed	Can be used to control other controllers (see example in section 4.5)	
			3	Controller status in C0135 format + frequency setpoint unsigned		
			4	402 Device profile: Statusword 0x6041		
			5	402 Device profile: Statusword 0x6041 + vl control effort 0x6044	<ul style="list-style-type: none"> vl control effort units = signed RPM RPM calculation based on C87 and C89 	
6	C0150 + C50 signed and scaled + digital input	C50 scaling: $\pm 16384 = C11$				
h87	TPDO#1 WORD0 bit mask	65535	0	65535	<ul style="list-style-type: none"> COS (change of state) bit mask applied to WORD0 of TPDO selected by h86. h87 = 65535: activates all bits of WORD0 for COS triggering h87 = 0: disables COS triggering 	
h89	TPDO#1 status		0	255	<ul style="list-style-type: none"> Read-only Number of transmitted TPDO#1 messages Above 255, starts over at 0 	

⁽¹⁾ These parameters take effect only after power-up, h58 reset, "NMT reset node", or "NMT reset communication services"

Commissioning



Code		Possible Settings		IMPORTANT		
No.	Name	Lenze	Selection			
TPDO#2 configuration parameters						
h90⁽¹⁾	TPDO#2 COB ID	641	0	2047	If h53 = 0, 2: Setting will change to 640 + Node ID during power-up or h58 reset.	
h91⁽¹⁾	TPDO#2 enable/disable	0	0	Disable	Enable individual polling of TPDO#2	
			1	Enable (no RTR)		
			2	Enable (with RTR)		
h92	TPDO#2 transmission type	255	0	255	<ul style="list-style-type: none"> h92 = 0...240: Transmit TPDO#2 after every nth SYNC received + Event + RTR (if enabled) h92 = 253: Event + RTR (if enabled) h92 = 254: COS triggered (WORD0 of TPDO#2) + Event + RTR (if enabled) h92 = 255: Event + RTR (if enabled) 	
h93⁽¹⁾	TPDO#2 inhibit time	50	0	{0.1 ms}	65535	Sets minimum time between TPDO#2 transmissions (h93 = 50 = 5.0 ms)
h94	TPDO#2 event timer	0	0	{ms}	65535	<ul style="list-style-type: none"> Sets the fixed interval for TPDO#2 transmission h94 = 0: disables event timer
h95⁽¹⁾	TPDO#2 mapping (see TPDO mapping details)	0	0	C0150 + C50 signed	C50 scaling: $\pm 50 = \pm 1.0$ Hz	
			1	C0150 + C50 unsigned	C50 scaling: 10 = 1.0 Hz	
			2	Controller status in C0135 format + frequency setpoint signed	Can be used to control other controllers (see example in section 4.5)	
			3	Controller status in C0135 format + frequency setpoint unsigned		
			4	402 Device profile: Statusword 0x6041	<ul style="list-style-type: none"> vI control effort units = signed RPM RPM calculation based on C87 and C89 	
			5	402 Device profile: Statusword 0x6041 + vI control effort 0x6044		
6	C0150 + C50 signed and scaled + digital input	C50 scaling: $\pm 16384 = C11$				
h97	TPDO#2 WORD0 bit mask	65535	0	65535	<ul style="list-style-type: none"> COS (change of state) bit mask applied to WORD0 of TPDO selected by h96. h97 = 65535: activates all bits of WORD0 for COS triggering h87 = 0: disables COS triggering 	
h99	TPDO#2 status		0	255	<ul style="list-style-type: none"> Read-only Number of transmitted TPDO#2 messages Above 255, starts over at 0 	
n20	Power up state	0	0	Quick stop	Selects controller power up state when C01 = 3 (CANopen control)	
			1	Inhibit		

⁽¹⁾ These parameters take effect only after power-up, h58 reset, "NMT reset node", or "NMT reset communication services"



Commissioning

4.4 CANopen mapping details

4.4.1 RPDO mapping details (h66 / h76)

	Bit	h66 / h76 setting = 0
		0
WORD0 - C0135 control word	1	Direction of rotation 0 = CW (forward) 1 = CCW (reverse)
	2	Quick stop 0 = Quick stop not active 1 = Quick stop active
	3	reserved
	4	reserved
	5	reserved
	6	reserved
	7	reserved
	8	reserved
	9	Controller inhibit 0 = No controller inhibit 1 = Controller inhibit
	10	reserved
	11	TRIP reset TRIP reset on transition from 0 to 1
	12	reserved
	13	reserved
	14	DC brake 0 = DC brake not active 1 = DC brake active
	15	reserved
WORD1		<ul style="list-style-type: none"> Signed frequency setpoint written to C46 Frequency setpoint [Hz] = WORD1 value / 50 Example 1: Requested setpoint = CW at 34.5 Hz = $34.5 \times 50 = 1725 = 0x06BD$ Example 2: Requested setpoint = CCW at 44.5 Hz = $-(44.5 \times 50) = -2225 = 0xF74F$ <p>Note: Setpoint sign overrides Bit 2 in WORD0</p>
WORD2		reserved (not evaluated)
WORD3		reserved (not evaluated)

	Bit	h66 / h76 setting = 1
		0
WORD0 - C0135 control word	1	Direction of rotation 0 = CW (forward) 1 = CCW (reverse)
	2	Quick stop 0 = Quick stop not active 1 = Quick stop active
	3	reserved
	4	reserved
	5	reserved
	6	reserved
	7	reserved
	8	reserved
	9	Controller inhibit 0 = No controller inhibit 1 = Controller inhibit
	10	reserved
	11	TRIP reset TRIP reset on transition from 0 to 1
	12	reserved
	13	reserved
	14	DC brake 0 = DC brake not active 1 = DC brake active
	15	reserved
WORD1		<ul style="list-style-type: none"> Unsigned frequency setpoint written to C46 Frequency setpoint [Hz] = WORD1 value / 10 Example: Requested setpoint = CW at 34.5 Hz = $34.5 \times 10 = 0x0159$ <p>• Direction is set by Bit 2 in WORD0</p>

Commissioning



WORD0 - Controlword 0x6040	Bit	h66 / h76 setting = 2
	0	0 = switch off ⁽²⁾ 1 = switch on
	1	0 = disable voltage ⁽²⁾ 1 = enable voltage
	2	0 = execute quick stop 1 = not quick stop
	3	0 = inhibit ⁽²⁾ 1 = enable
	4	reserved
	5	reserved
	6	reserved
	7	fault reset on transition from 0 to 1
	8	0 = execute motion 1 = halt ⁽²⁾
	9	reserved
	10	reserved
	11	Direction of rotation 0 = CW (forward) 1 = CCW (reverse)
	12	JOG1, JOG2, JOG3 0 = C46 active 1 = JOG1 (C37) active
	13	2 = JOG2 (C38) active 3 = JOG3 (C39) active
	14	DC brake 0 = DC brake not active 1 = DC brake active
15	reserved	

WORD0 - Controlword 0x6040	Bit	h66 / h76 setting = 3
	0	0 = switch off ⁽²⁾ 1 = switch on
	1	0 = disable voltage ⁽²⁾ 1 = enable voltage
	2	0 = execute quick stop 1 = not quick stop
	3	0 = inhibit ⁽²⁾ 1 = enable
	4	reserved
	5	reserved
	6	reserved
	7	fault reset on transition from 0 to 1
	8	0 = execute motion 1 = halt ⁽²⁾
	9	reserved
	10	reserved
	11	Direction of rotation 0 = CW (forward) 1 = CCW (reverse)
	12	JOG1, JOG2, JOG3 0 = C46 active 1 = JOG1 (C37) active
	13	2 = JOG2 (C38) active 3 = JOG3 (C39) active
14	DC brake 0 = DC brake not active 1 = DC brake active	
15	reserved	

WORD1	<ul style="list-style-type: none"> Signed vl target velocity 0x6042 (RPM) RPM is calculated based on C87 and C89 Example 1 (C87 = 1390 RPM, C89 = 50 Hz): Requested setpoint CW at 25.0 Hz = $25.0 \times 1390 / 50 = 695 = 0x02B7$ Example 2 (C87 = 1390 RPM, C89 = 50 Hz): Requested setpoint CCW 44.5 Hz = $-(44.5 \times 1390 / 50) = -1237 = 0xFB2B$ 	
-------	---	--

⁽²⁾ Implemented as inhibit; all indicated bits must be in opposite state for controller to be enabled.



Commissioning

Bit	h66 / h76 setting = 4
0	JOG1, JOG2, JOG3 0 = C46 active 1 = JOG1 (C37) active 2 = JOG2 (C38) active 3 = JOG3 (C39) active
1	
2	Direction of rotation 0 = CW (forward) 1 = CCW (reverse)
3	Quick stop 0 = Quick stop not active 1 = Quick stop active
4	reserved
5	reserved
6	reserved
7	reserved
8	reserved
9	Controller inhibit 0 = No controller inhibit 1 = Controller inhibit
10	reserved
11	TRIP reset TRIP reset on transition from 0 to 1
12	reserved
13	reserved
14	DC brake 0 = DC brake not active 1 = DC brake active
15	reserved
WORD1	<ul style="list-style-type: none"> Speed signed scaled +/- 16384 == C11 (max frequency) Example 1: Requested setpoint = CW at 34.5 Hz and C11 = 50.0Hz: Setpoint = $\text{roundup}(34.5 * 16384/50) = 11305$ = 0x2C29 Example 2: Requested setpoint = CCW at 44.5 Hz and C11 = 50.0Hz: = $-\text{roundup}(44.5 * 16384/50) = -14582 = 0xC70A$ Note: Setpoint sign overrides Bit 2 in WORD0
WORD2	Digital outputs (RELAY + E3) <ul style="list-style-type: none"> Bit 0 - RELAY - (if C08 set to selection 9) Bit 1 - E3 (if CE3 set to selection 30)
WORD3	reserved (not evaluated)



4.4.2 TPDO mapping details (h86 / h96)

	Bit	h86 / h96 setting = 0
	WORD0 - C0150 Status word	0
1		0 = Pulses to power stage enabled 1 = Pulses to power stage Inhibited
2		0 = Current limit not reached 1 = Current limit reached
3		reserved
4		0 = Actual frequency < > setpoint 1 = Actual frequency = setpoint
5		0 = Not above threshold 1 = Above threshold (C17)
6		0 = Actual frequency < > 0 Hz 1 = Actual frequency = 0 Hz
7		0 = No controller inhibit 1 = Controller inhibit
8		Controller status 0 = no fault 8 = fault present
9		
10		
11		
12		0 = No overtemperature warning 1 = Overtemperature warning
13		0 = No DC bus overvoltage 1 = DC bus overvoltage
14		Direction of rotation 0 = CW (forward) 1 = CCW (reverse)
15	0 = Not ready 1 = Ready (no faults)	
WORD1		<ul style="list-style-type: none"> • Signed output frequency read from C50 • Scaling = C50 x 50 • Example 1: CW at 34.5 Hz = 34.5 x 50 = 1725 = 0x06BD • Example 2: CCW at 44.5 Hz = - (44.5 x 50) = -2225 = 0xF74F
WORD2		reserved
WORD3		reserved

	Bit	h86 / h96 setting = 1
	WORD0 - C0150 Status word	0
1		0 = Pulses to power stage enabled 1 = Pulses to power stage Inhibited
2		0 = Current limit not reached 1 = Current limit reached
3		reserved
4		0 = Actual frequency < > setpoint 1 = Actual frequency = setpoint
5		0 = Not above threshold 1 = Above threshold (C17)
6		0 = Actual frequency < > 0 Hz 1 = Actual frequency = 0 Hz
7		0 = No controller inhibit 1 = Controller inhibit
8		Controller status 0 = no fault 8 = fault present
9		
10		
11		
12		0 = No overtemperature warning 1 = Overtemperature warning
13		0 = No DC bus overvoltage 1 = DC bus overvoltage
14		Direction of rotation 0 = CW (forward) 1 = CCW (reverse)
15	0 = Not ready 1 = Ready (no faults)	
WORD1		<ul style="list-style-type: none"> • Unsigned output frequency read from C50 • Scaling = C50 x 10 • Example: CW at 34.5 Hz = 34.5 x 10 = 345 = 0x0159 • Direction is indicated by bit 14 in WORD0



Commissioning

WORD0 - Controller status in C0135 format	Bit	h86 / h96 setting = 2	
	0	1	JOG1, JOG2, JOG3 0 = C46 active 1 = JOG1 (C37) active 2 = JOG2 (C38) active 3 = JOG3 (C39) active
			Direction of rotation 0 = CW (forward) 1 = CCW (reverse)
	2	Quick stop 0 = Quick stop not active 1 = Quick stop active	
	3	reserved	
	4	reserved	
	5	reserved	
	6	reserved	
	7	reserved	
	8	reserved	
	9	Controller inhibit 0 = No controller inhibit 1 = Controller inhibit	
	10	reserved	
	11	TRIP reset 0 = No TRIP reset 1 = TRIP reset	
	12	reserved	
	13	reserved	
14	DC brake 0 = DC brake not active 1 = DC brake active		
15	reserved		
WORD1	<ul style="list-style-type: none"> Signed frequency setpoint [Hz] Scaling = frequency setpoint [Hz] x 50 Example 1: CW at 34.5 Hz = 34.5 x 50 = 1725 = 0x06BD Example 2: CCW at 44.5 Hz = - (44.5 x 50) = -2225 = 0xF74F 		
WORD2	reserved		
WORD3	reserved		

WORD0 - Controller status in C0135 format	Bit	h86 / h96 setting = 3	
	0	1	JOG1, JOG2, JOG3 0 = C46 active 1 = JOG1 (C37) active 2 = JOG2 (C38) active 3 = JOG3 (C39) active
			Direction of rotation 0 = CW (forward) 1 = CCW (reverse)
	2	Quick stop 0 = Quick stop not active 1 = Quick stop active	
	3	reserved	
	4	reserved	
	5	reserved	
	6	reserved	
	7	reserved	
	8	reserved	
	9	Controller inhibit 0 = No controller inhibit 1 = Controller inhibit	
	10	reserved	
	11	TRIP reset 0 = No TRIP reset 1 = TRIP reset	
	12	reserved	
	13	reserved	
14	DC brake 0 = DC brake not active 1 = DC brake active		
15	reserved		
WORD1	<ul style="list-style-type: none"> Unsigned frequency setpoint [Hz] Scaling = frequency setpoint [Hz] x 10 Example: CW at 34.5 Hz = 34.5 x 10 = 345 = 0x0159 Direction is indicated by bit 2 in WORD0 		

Commissioning



WORD0 - Statusword 0x6041	Bit	h86 / h96 setting = 4
	0	0 = Not ready to switch on 1 = Ready to switch on
	1	0 = Not switched on 1 = Switched on
	2	0 = operation disabled 1 = operation enabled
	3	0 = No fault 1 = Fault
	4	0 = Voltage disabled 1 = Voltage enabled Note: On smd controller, this is always enabled
	5	0 = Quick stop active 1 = Quick stop not active
	6	Switch on disabled On smd controller this is always 0 (switch on enabled)
	7	0 = No warning 1 = Warning
	8	Manufacturer specific
	9	Remote 0 = C01 < > 2 and 3 1 = C01 = 2 or 3
	10	Target reached 0 = Setpoint not reached 1 = Setpoint reached
	11	Internal limit 0 = Internal limit not active 1 = Internal limit active
	12	reserved
	13	reserved
	14	reserved
15	reserved	

WORD0- Statusword 0x6041	Bit	h86 / h96 setting = 5
	0	0 = Not ready to switch on 1 = Ready to switch on
	1	0 = Not switched on 1 = Switched on
	2	0 = operation disabled 1 = operation enabled
	3	0 = No fault 1 = Fault
	4	0 = Voltage disabled 1 = Voltage enabled Note: On smd controller, this is always enabled
	5	0 = Quick stop active 1 = Quick stop not active
	6	Switch on disabled On smd controller this is always 0 (switch on enabled)
	7	0 = No warning 1 = Warning
	8	Manufacturer specific
	9	Remote 0 = C01 < > 2 and 3 1 = C01 = 2 or 3
	10	Target reached 0 = Setpoint not reached 1 = Setpoint reached
	11	Internal limit 0 = Internal limit not active 1 = Internal limit active
	12	reserved
	13	reserved
14	reserved	
15	reserved	

WORD1	<ul style="list-style-type: none"> Signed output frequency read from C50 RPM is calculated based on C50, C87, and C89 Example 1 (C87 = 1390 RPM, C89 = 50 Hz): CW at 25.0 Hz = $25.0 \times 1390/50 = 695 = 0x02B7$ Example 2 (C87 = 1390 RPM, C89 = 50 Hz): CCW at 44.5 Hz = $-(44.5 \times 1390/50) = -1237 = 0xFB2B$ 	
-------	---	--



Commissioning

Bit	h86 / h96 setting = 6
0	reserved
1	0 = Pulses to power stage enabled 1 = Pulses to power stage Inhibited
2	0 = Current limit not reached 1 = Current limit reached
3	reserved
4	0 = Actual frequency < > setpoint 1 = Actual frequency = setpoint
5	0 = Not above threshold 1 = Above threshold (C17)
6	0 = Actual frequency < > 0 Hz 1 = Actual frequency = 0 Hz
7	0 = No controller inhibit 1 = Controller inhibit
8	Controller status 0 = no fault 8 = fault present
9	
10	
11	0 = No overtemperature warning 1 = Overtemperature warning
12	
13	0 = No DC bus overvoltage 1 = DC bus overvoltage
14	Direction of rotation 0 = CW (forward) 1 = CCW (reverse)
15	0 = Not ready 1 = Ready (no faults)
WORD1	<ul style="list-style-type: none"> Signed output frequency read from C50 signed scaled +/- 16384 = C11 (max frequency) Scaling = $C50 * 16384 / C11$ Example 1: WORD1 = 0x2C29, C11 = 50.0Hz Direction = $\text{Sign}(0x2C29) = \text{CW}$ Frequency = $\text{ABS}(0x2C29) * C11 / 16384 = 11305 * 50 / 16384 = \mathbf{34.5 \text{ Hz CW}}$ Example 2: WORD1 = 0xC70A, C11 = 50.0Hz Direction = $\text{Sign}(0xC70A) = \text{CCW}$ Frequency = $\text{ABS}(0xC70A) * C11 / 16384 = 14582 * 50 / 16384 = \mathbf{44.5 \text{ Hz CCW}}$
WORD2	Digital inputs status (TB28, E1, E2, E3) <ul style="list-style-type: none"> Bit 0 - TB28 state (1 - asserted) Bit 1 - E1 state (1 - asserted) Bit 2 - E2 state (1 - asserted) Bit 3 - E3 state (1 - asserted)
WORD3	reserved

Commissioning



4.5 Quick CAN set-up

1. Power up the controller and set h50 (CAN address) and h51 (CAN baud rate) to appropriate values.
2. Power down the controller and connect the communication cable. For reliable communication make sure terminal CAN_GND is connected to CAN network GND/common. If only two wires are used (CAN_H and CAN_L) in the network, connect CAN_GND to chassis/earth ground.
3. Power up the controller.
4. Use Global Drive Control Software to configure the required operation of the controller.

Example: Controller #2 needs to follow the operation of controller #1 (start/stop, speed, etc). Controller #1 can be controlled by CANopen or traditional control elements (relays, etc).

Controller #1 configuration			Controller #2 configuration		
No.	Name	Setting	No.	Name	Setting
h50	CAN address (Node ID)	1	001	Setpoint source	3 CANopen control
h51	CAN baud rate	5 500 kbps	h45	Error behavior	1 No state change
h52	System bus participant	1 Slave with autostart enabled	h50	CAN address (Node ID)	2
h53	Parameter channel 2 (SDO#2)	0 Enable with default COB ID	h51	CAN baud rate	5 500 kbps
h84	TPDO#1 event timer	10 ms	h52	System bus participant	1 Slave with autostart enabled
h86	TPDO#1 mapping	3 Controller status in C0135 format + frequency setpoint unsigned	h53	Parameter channel 2 (SDO#2)	1 Enable with prog. COB ID
			h60	RPDO#1 COB ID	385 (h80 from controller #1)
			h64	RPDO#1 event monitoring timer	50 ms
			h65	RPDO#1 time out reaction	1 Inhibit
			h66	RPDO#1 mapping	1 C0135 control word + C46 frequency setpoint unsigned

After setting the parameters, perform Node reset using parameter h58 or cycle the power.

After these controllers are configured as above, controller #2 will follow the operation of controller #1 including: Inhibit state, Quick Stop, DC brake, JOG speed selections, direction, and speed. For additional safety, controller #2 will transition to inhibit state if valid PDO is not received from controller #1 within 50ms.



Troubleshooting and fault elimination

5 Troubleshooting and fault elimination

Status	Cause	Remedy	
e.g. SO.D	Present output frequency	Trouble free operation	
OFF	Stop (outputs U, V, W inhibited)	LOW signal at terminal 28	Set terminal 28 to HIGH
Inh	Inhibit (outputs U, V, W inhibited)	Controller is set up for CANopen control (see C01)	Start the controller via CANopen
StP	Output frequency = 0 Hz (outputs U, V, W inhibited)	Setpoint = 0 Hz	Setpoint selection
		Quick stop activated through digital input	Deactivate Quick stop
br	DC-injection brake active	DC-injection brake activated <ul style="list-style-type: none"> • via digital input • automatically 	Deactivate DC-injection brake <ul style="list-style-type: none"> • digital input = LOW • automatically after holding time c06 has expired
CL	Current limit reached	Controllable overload	Automatically (see C22)
LU	Undervoltage on DC bus	Mains voltage too low	Check mains voltage
dEC	Overvoltage on DC bus during deceleration (warning)	Excessively short deceleration time (C13)	Automatically if overvoltage < 1 s, OU , if overvoltage > 1 s
nEd	No access to code	Can only be changed when the controller is in OFF or Inh	Set terminal 28 to LOW or inhibit through CANopen

Error	Cause	Remedy ⁽¹⁾	
cF	Data not valid for controller	<ul style="list-style-type: none"> • Use EPM providing valid data • Load Lenze setting 	
CF	Data on EPM not valid		Data error
GF			OEM data not valid
F I	EPM error	EPM missing or defective	Power down and replace EPM
CFG	Digital inputs not uniquely assigned	E1...E3 assigned with the same digital signals	Each digital signal can only be used once
		Either just "UP" or "DOWN" used	Assign the missing digital signal to a second terminal
EEr	External error	Digital input "TRIP set" is active	Remove external error
F2...FD, JF	Internal fault		Please contact Lenze
FC3	CAN communication timeout	Monitored CAN messages not received	<ul style="list-style-type: none"> • Check h48 for cause • Increase timeout settings • Check CAN wiring
FCS	CAN initialization failed	CAN controller failure	<ul style="list-style-type: none"> • Perform CAN reset (h58) • Cycle power
LC	Automatic start inhibited	c42 = 0	LOW-HIGH signal change at terminal 28

(1) The drive can only be restarted if the error message has been reset; see c70

Troubleshooting and fault elimination



Error		Cause	Remedy ⁽¹⁾
DC I	Short-circuit or overload	Short-circuit	Find reason for short-circuit; check motor cable
		Excessive capacitive charging current of the motor cable	Use shorter motor cables with lower charging current
		Acceleration time (C12) too short	<ul style="list-style-type: none"> • Increase acceleration time • Check controller selection
		Defective motor cable	Check wiring
		Internal fault in motor	Check motor
		Frequent and long overload	Check controller selection
DC2	Earth fault	Grounded motor phase	Check motor/motor cable
		Excessive capacitive charging current of the motor cable	Use shorter motor cables with lower charging current
DC6	Motor overload (I ² t overload)	Motor is thermally overloaded, due to: <ul style="list-style-type: none"> • impermissible continuous current • frequent or too long acceleration processes 	<ul style="list-style-type: none"> • Check controller selection • Check setting of c20
DH	Controller overtemperature	Controller too hot inside	<ul style="list-style-type: none"> • Reduce controller load • Improve cooling
DU	Overvoltage on DC bus	Mains voltage too high	Check mains voltage
		Excessively short deceleration time or motor in generator mode	Increase deceleration time or use dynamic braking option
		Earth leakage on the motor side	Check motor/motor cable (separate motor from controller)
rSt	Faulty auto-TRIP reset	More than 8 errors in 10 minutes	Depends on the error
SF	Single phase fault	A mains phase has been lost	Check mains voltage

(1) The drive can only be restarted if the error message has been reset; see c70



Notes

Document
SW03B-en3