

COMBIVERT

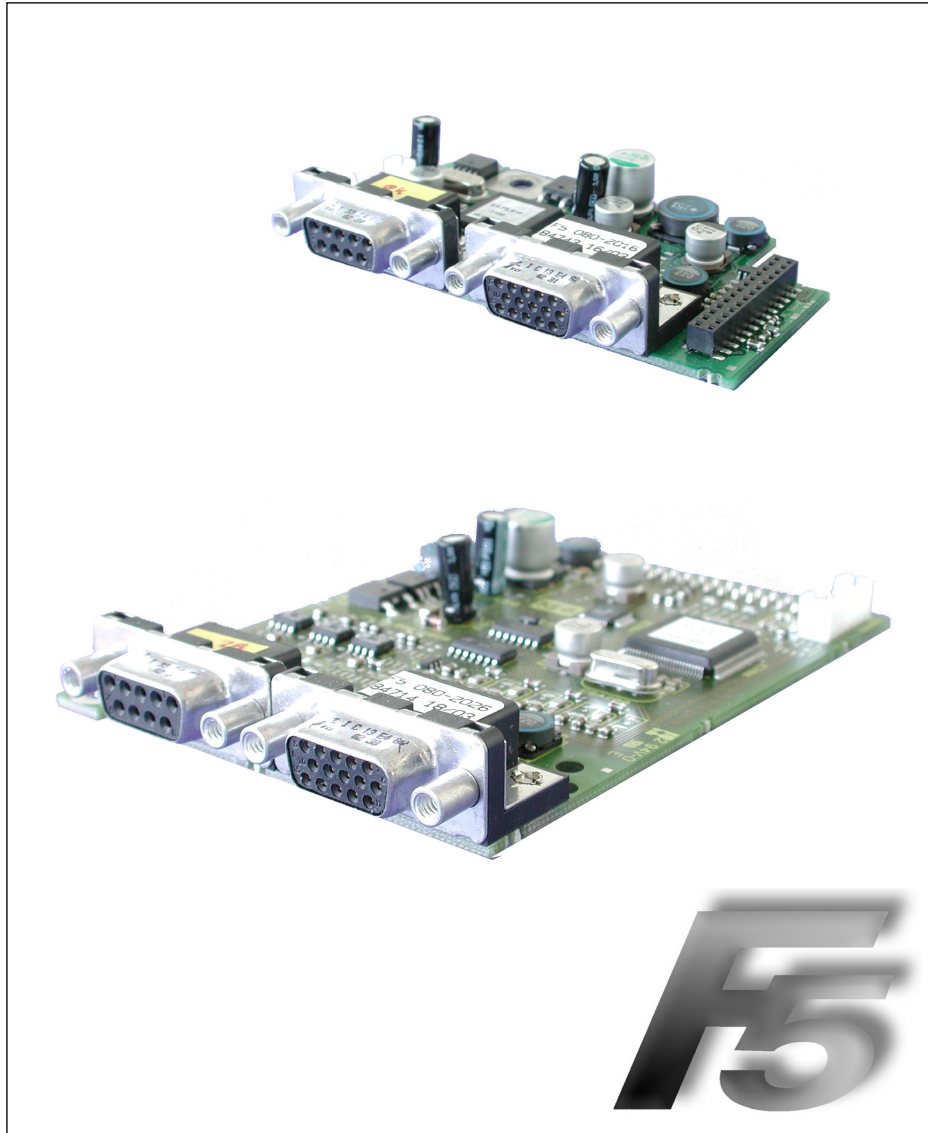

GB INSTRUCTION MANUAL

Channel 1
Channel 2

Encoder Interface

SSI-SIN/COS
variable

Mat.No.	Rev.
DSF5ZEM-K010	1E

1. Safety Instructions	4
1.1 Validity	4
1.2 Qualification.....	4
2. Product Description.....	5
2.1 General.....	5
2.2 Material number	5
2.3 Scope of delivery (option or replacement delivery)	5
2.4 Mechanical installation	6
3. Description of the Interface	6
3.1 Voltage supply	6
3.2 Channel 1	7
3.2.1 Specifications	7
3.2.2 Description of X3A.....	7
3.2.3 Input signals channel 1.....	8
3.2.3.1 Synchronous serial interface (SSI).....	8
3.2.3.2 Analog input signals of the process data channel	9
3.2.3.3 Encoder monitoring	9
3.2.4 Connection of the encoder	10
3.2.4.1 Encoder cabel at SUB-D15	10
3.2.5 Encoder cable	10
3.2.6 Encoder line length.....	11
3.2.7 Tested encoders	11
3.3 Channel 2.....	11
4. Start-up	11
4.1 Parameter description	12
4.1.1 Encoder 1 status (Ec.37).....	12
4.1.2 Encoder 1 SSI data format (Ec.43)	13
4.1.3 Encoder 1 SSI single-turn resolution (Ec.44)	13
4.1.4 Encoder 1 SSI multiturn resolution (Ec.53)	13
4.1.5 Encoder 1 SSI mode (Ec.54).....	14

1. Safety Instructions

Prior to performing any work on the unit the user must familiarize himself with the unit. This includes especially the knowledge and observance of the safety and warning directions. The pictographs used in this instruction manual have following meaning:



Danger Refers to danger of life by electric current.



Warning Refers to possible danger of injury or life.



Note Refers to tips and additional information.

1.1 Validity

The information contained in the technical documentation, as well as any user-specific advice in spoken and written and through tests, are made to best of our knowledge and information about the application. However, they are considered for information only without responsibility. This also applies to any violation of industrial property rights of a third-party.

Inspection of our units in view of their suitability for the intended use must be done generally by the user. Inspections are particularly necessary, if changes are executed, which serve for the further development or adaption of our products to the applications (hardware, software or download lists). Inspections must be repeated completely, even if only parts of hardware, software or download lists are modified.



Controlling by the user Application and use of our units in the target products is outside of our control and therefore lies exclusively in the area of responsibility of the user.



Use under special conditions

The used semiconductors and components of KEB are developed and dimensioned for the use in industrial products. If the KEB COMBIVERT is used in machines, which work under exceptional conditions or if essential functions, life-supporting measures or an extraordinary safety step must be fulfilled, the necessary reliability and security must be ensured by the machine builder.

1.2 Qualification

All operations serving transport, installation and commissioning as well as maintenance are to be carried out by skilled technical personnel (observe IEC 364 or CENELEC HD 384 or DIN VDE 0100 and national accident prevention rules!). According to this manual qualified staff means:

- those who are able to recognise and judge the possible dangers based on their technical training and experience

- those with knowledge of the relevant standards and who are familiar with the field of power transmission (VDE 0100, VDE 0160 (EN 50178), VDE 0113 (EN 60204) as well as the appropriate regulations for your area.



Danger by high voltage

KEB electronics components contain dangerous voltages which can cause death or serious injury. In operation, drive converters, depending on their degree of protection, may have live, uninsulated, and possibly also moving and hot surfaces.

In case of inadmissible removal of the required covers, of improper use, wrong installation or maloperation, there is the danger of serious personal injury and damage to property.

2. Product Description

Figure 1: SSI-SIN/COS at channel 1

X3B Channel 2 see material number	X3A Channel 1 SSI-SIN/COS
--	--

2.1 General

Each of the interface cards delivered by KEB include two interfaces. As there are numerous different combinations available each interface will be described by means of separate instructions. The instruction covers the installation of the interface card, the connection as well as the start-up of a suitable encoder. Further information and the parameter adjustments are described in the application manual for the inverter/servo.

2.2 Material number

xM	F5	K8x	X	X	X	X			
			Term of delivery	0	installed	Z	Option, spare part		
			Interface X3A	V	TTL output	2027	U	TTL input	2024
				Y	as V, but with software 1.4 from 15.06.2007			2027	
			F5	Series					
applicable for housing size			1M	D, E (circuit board 1M.F5.280-xxxx see above)					
			2M	G...U (circuit board 2M.F5.280-xxxx see above)					

2.3 Scope of delivery (option or replacement delivery)

- Encoder interface
- two instruction manuals
- fixing bolt
- packing material

2.4 Mechanical installation

All kind of works on the inverter may be carried out by authorized personnel in accordance with the EMC and safety rules only.

- Switch inverter de-energized and await capacitor discharge time
- Pull off operator
- Remove plastic cover
- Remove fixing bolt
- Fix interface board beginning from the socket connector straightly
- Screw in fixing bolt
- Adjust desired supply voltage with DIL switch
- Attach plastic cover

3. Description of the Interface

3.1 Voltage supply

Figure 3.1 Voltage supply of control and encoder interfaces		
U_{int}	24 VDC	Internal voltage supply of COMBIVERT.
I_{int}	120 mA	at Hiperface, Sin/Cos, EnDat, SSI-Sin/Cos and UVW.
	170 mA	at all other encoder interfaces.
U_{ext}	Control terminal strip (X2A) of the COMBIVERT with external voltage supply 24...30 DCV.	
24 V	Voltage output of encoder interfaces X3A and X3B for encoder supply.	
I_{24V}	Current I_{int} reduces itself by draw current to the 5V output in accordance with the following formula: $I_{24V} = I_{int} - \frac{5,2_{V} \times I_{5V}}{U_{int}}$	
5 V	Voltage output for encoder supply. 5,2V are obtained from the 24 V voltage.	
I_{5V}	300 mA	at Hiperface, Sin/Cos, EnDat, SSI-Sin/Cos and UVW.
	500 mA	at all other encoder interfaces.
	1 A	at external supply (dependent on the voltage source)

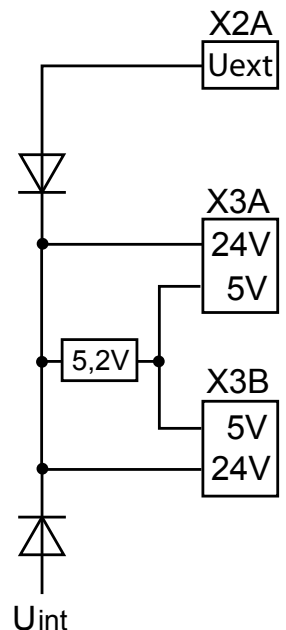

3.2 Channel 1

3.2.1 Specifications

X3A	Socket SUB-D15		
Interface type	SSI-SIN/COS	SSI (absolute track)	
		SIN/COS (incremental encoder track)	
Inputs / tracks	Process data channel	A, B	1 Vss typical (0,6...1,2)
	Parameter channel	Data	EIA RS485 half duplex, binary-coded, Gray Code
	Clock signal	Clock	EIA RS485
Limiting frequency	200 kHz		
Increments per revolution	1...2048 ^{inc} (recommendation 1024 ^{inc} for speed upto 4500rpm)		
Input resistance	120 Ω		
Max. line length	50m, the value is additionally limited by the signal frequency, cable capacity and supply voltage (see chapter „encoder line length“).		

3.2.2 Description of X3A

Figure 3.2.2 Socket X3A		
PIN	Name	Description
1	-	-
2	-	-
3	A-	Signal input A- (difference signal to A+)
4	B-	Signal input B- (difference signal to B+)
5	-	-
6	Clock+	Clock signal RS485
7	Clock-	Clock signal RS485
8	A+	Incremental encoder input track A for counter and direction detection
9	B+	Incremental encoder input B for counter and direction detection
10	-	-
11	24 V	Power supply for encoder
12	+5,25V	Power supply for encoder
13	COM	Reference potential for voltage supply
14	-DATA	Data channel RS485
15	+DATA	Data channel RS485
-	GND	Connection for shield at the connector housing (is directly connected with the inverter earth).

3.2.3 Input signals channel 1

During start-up and then all 30 ms an inquiry is transmitted to the encoder and the absolute position is serial read out. Thus a reference point search is not necessary.

A position difference is tracked after filter with ramp time. If this difference increases too quickly, so that it cannot keep tracked or a max. value is exceeded (e.g. at encoder breakage), the interface state Ec.37 changes to „69“ and the inverter switches off. The clock signal is used for synchronization.

3.2.3.1 Synchronous serial interface (SSI)

Singleturn absolute encoder divide one revolution of the shaft into a defined number of measuring steps. This are 4096 positions at a SSI protocol, corresponding to a resolution of 12 Bit. This value is adjusted with Ec.44.

Multiturn absolute encoder do not only detect angle positions within one revolution but also the number of revolutions. With a resolution of the multiturn part of 12 Bit standard this corresponds to 4096 revolutions. The resolution of the multiturn rate is adjusted with Ec.53. This value is adjusted to „0 “ at singleturn encoders.

The position measuring area of $0 \dots 2^{24} - 1$ should not be left, since an overflow and/or underflow is not evaluated as error. A system offset can be defined by writing on Ec.34 or approaching to reference point.

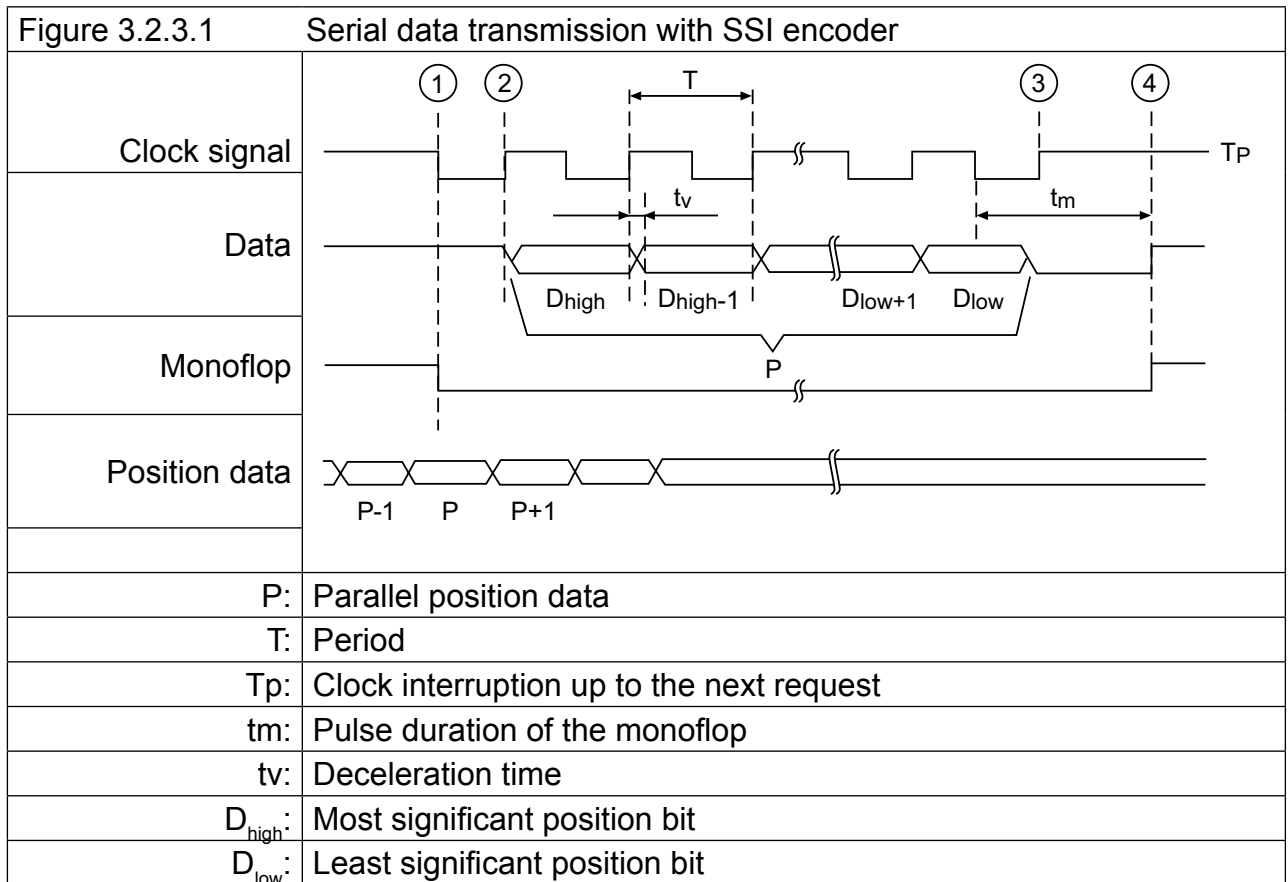

3.2.3.2 Analog input signals of the process data channel

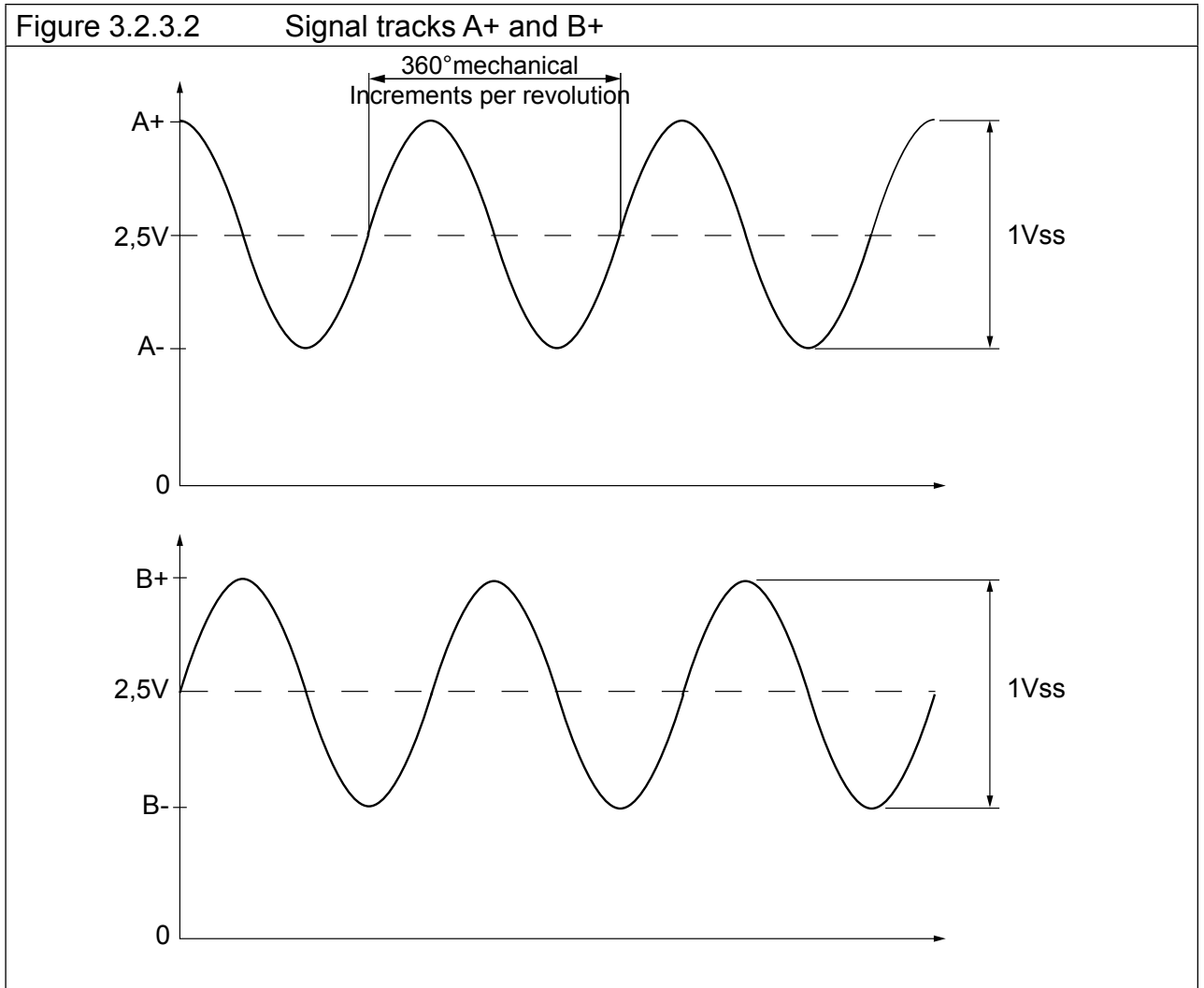

3.2.3.3 Encoder monitoring

Parameter	r/w	Enter	prog.
Ec.42 Encoder alarm mode	yes	no	no
<p>The encoder monitoring is a software function and dependent on the encoder type. The incremental track is monitored approx. all 16 ms. If the permissible signal levels are fallen below „Error! Encoder 1“ (value 32) is triggered. Also the absolute track, i.e. the serial communication to the encoder is monitored. If the encoder gives not an answer, or a communication is not possible, the respective state message will be transmitted to the inverter. Dependent on the encoder type the response time can be 100 ms and more.</p>			
Setting range	Setting	Meaning	
0	1	Encoder monitoring off	
1		Encoder monitoring on	
2		Encoder monitoring on (open-loop off)	
3		Warning	

3.2.4 Connection of the encoder

3.2.4.1 Encoder cable at SUB-D15

- Encoder cable double-shielded and twisted in pairs
- Connect exterior shielding at both ends to PE/GND
- Connect interior shieldings at one side to COM
- Do not connect exterior and interior shielding

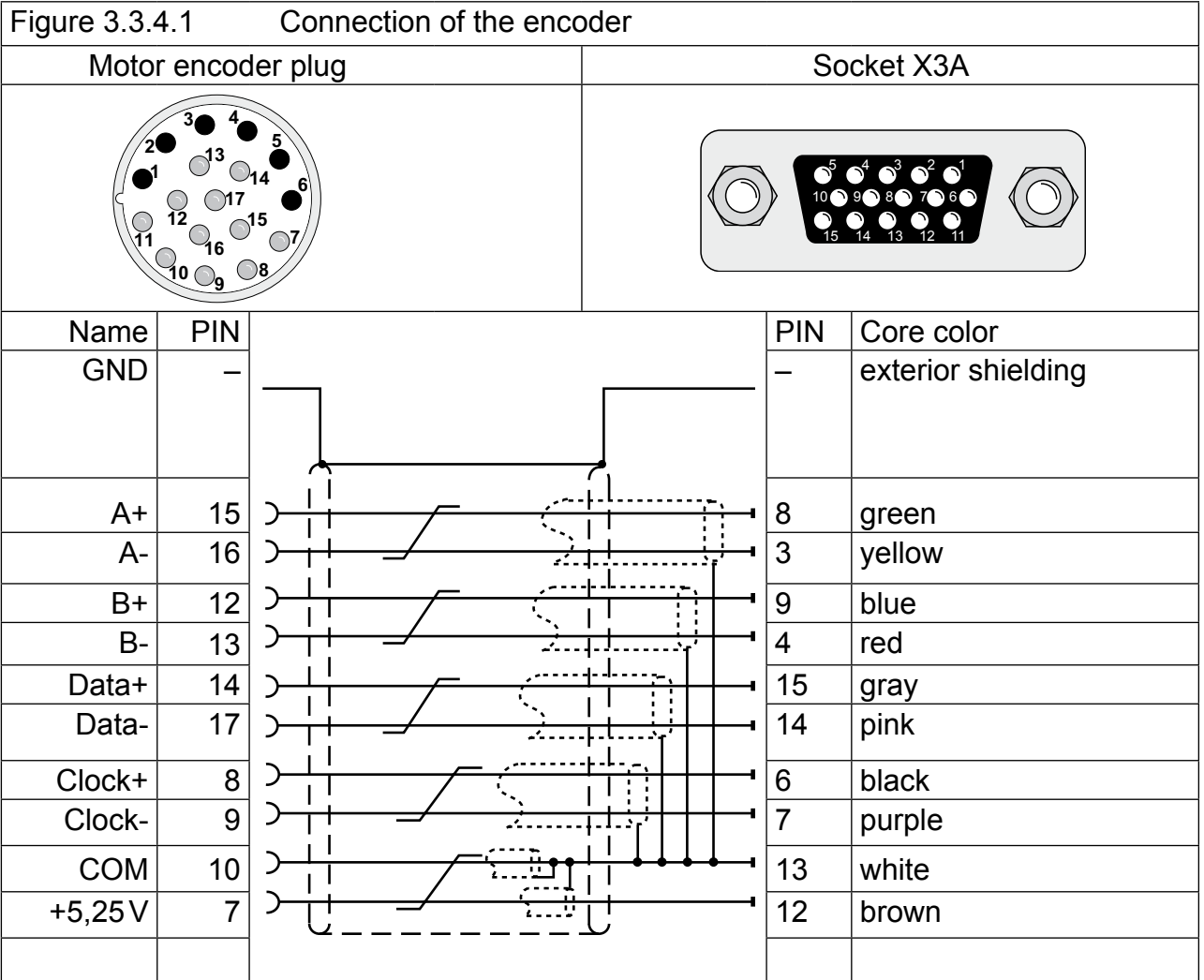

3.2.5 Encoder cable

KEB encoder cables are corresponding to the following specification:

Signal lines	4 x (2 x 0,14 mm ²)
Supply lines	2 x (0,5 mm ²)
Particularities	trailing capable, oil resistant
Temperature range	constant up to 80 °C
Color	green RAL 6018
Material number	00.F5.0C1-4xxx

3.2.6 Encoder line length

The maximum line length is 50m. It results from the voltage drop of the supply line. The value is calculated as follows:

Encoder cable length =	$\frac{U - U_{min}}{I_{max} \cdot 2 \cdot R}$
max. encoder current I_{max} :	see encoder description
Supply voltage U:	5,2V
min. supply voltage U_{min} :	see encoder description
KEB encoder cable resistance R:	0,036 Ω /m at 0,5 mm ²

3.2.7 Tested encoders

The following encoders can be used dependent on the interface and control:

Software Interface	Software Control board	Encoder type
<=1.3	-	Encoder with 256 inc./rev. and 10 bit binary SSI word (e.g. Hübner MHGA 400). At this the following parameters are not adjustable: Ec.1 = 256 Ec.43 = 0 Ec.44 = 10
>= 1.4	>=2.9 (Multi) >=3.2 (A-Servo)	Number of increments per revolution of the encoder as well as data code and data word length of the SSI data word are adjustable (e.g. Heidenhain ECN1313).

However, this does not restrict the use of rotary encoder with same specifications of other manufacturers.

3.3 Channel 2

The description of input X3B is depending on the used encoder interface. It is described in a separate manual.

4. Start-up

After the installation or exchange of an encoder interface some adjustments of the inverter/ servo software have to be done before operation:

- Switch on inverter
- Select application mode
- When using synchronous motors set ud.2 to F5-S
- Select parameter Ec.00 and control whether „SSI-SIN/COS“ is entered. The displayed value has to be confirmed by „ENTER“ in any case.
- Select parameter Ec.10 and carry out the same for the 2. encoder interface
- Depending on the encoder interface and control card (see 3.3.7) control/adjust the number of increments per rev. (Ec.1), the SSI data code (Ec.43) and the SSI data word length (Ec.44 and Ec.53).
- Select parameter Ec.37 and control encoder status.

4.1 Parameter description

4.1.1 Encoder 1 status (Ec.37)

This parameter displays, by means of different status messages, the status of encoder and interface. Dependent on the encoder only special messages are possible. All errors are only set at control release, although they are already displayed in Ec.37.

Value	Description
The following value is displayed at correct operation:	
16	Position values are being transferred, encoder and interface are working
The following status messages triggers „Error Encoder Change“ (E.EncC) because the correct evaluation of the position is no longer guaranteed. Error E.EncC can only be reset via parameter Ec.0. Exception! An error due to wrong increments per revolution (value 70) is reset immediately, if the correct increments per revolution are adjusted (from software 2.7). Attention, the modulation is released, when the control release is still set!	
64	Encoder is unknown and will not be supported
67	The signals of the incremental track are not correct, e.g. no encoder is connected or the encoder cable is defective.
68	The signals of the absolute track are not correct. The absolute track at Endat, Hiperface and SSI-Sin/Cos is digital. The absolute track at Sin/Cos is analog.
69	Position deviation too high. The position determined by the incremental signals and the absolute position (of absolute track, zero signal or serial selected) does no longer correspond or cannot be corrected.
70	Increments per revolution adjusted in the inverter does not correspond with encoder increments per revolution.
71	Interface type is unknown: Interface has not been recognized.
75	Encoder temperature too high (message from encoder)
76	Rotary speed is too high (message from encoder)
77	Encoder signals are outside the specification (message from encoder)
78	Encoder has internal defect (message from encoder)
92	Encoder will be formatted. When writing an encoder with memory structures different from the KEB-definition, their memories will be re-organized in such a manner that they can be written. This procedure can take some seconds, depending on the respective memory structure.
96	New value detected, because an another encoder is attached.
98	Interface is busy
The following status messages triggers „Error Encoder 1“ (E.Enc1), if encoder data is read:	
further on next page	

Value	Description
97	KEB-reference is undefined. Memory structure of the encoder does not correspond to the KEB-definition and therefore data cannot be read. The encoder is defined by writing data. At F5-S the error is reset as follow: <ul style="list-style-type: none"> • writing a position to Ec.2. • perform a system position trimming
Following status messages trigger error „Error Hybrid“ (E.HYb):	
0,255	No communication between interface and control card.

4.1.2 Encoder 1 SSI data format (Ec.43)
(from interface software 1.4 and control card software 3.2)

Parameter	r/w	Enter	prog.
Ec.43 Encoder 1 SSI data format	yes	yes	no
This parameter sets the data format of the connected encoder.			
Setting range	Setting	Meaning	
0	0	Binary code	
1		Gray code	

4.1.3 Encoder 1 SSI single-turn resolution (Ec.44)

Parameter	r/w	Enter	prog.
Ec.44 Encoder 1 SSI single-turn resolution	yes	yes	no
This parameter sets the number of bits of the SSI data word to the connected encoder (see also 3.2.7). The resolution for the multiturn encoder is adjusted in Ec.53.			
Setting range	Setting	Meaning	
0...13 Bit	10 Bit	The resolution of the digital single-turn absolute position is determined by the number of bits.	

4.1.4 Encoder 1 SSI multiturn resolution (Ec.53)
(from interface software 1.5 and control card software 3.3)

Parameter	r/w	Enter	prog.
Ec.53 Endoer 1 SSI multiturn resolution	yes	yes	no
This parameter sets the number of bits of the SSI data word from the multiturn part of the connected encoder. It is the multiturn part of the SSI data word (whole number of completed revolutions) stored by the encoder (mostly 12 bit for 4096 revolutions). When output the SSI data word, the encoder must first output the multiturn part (Ec.53) and then the single-turn part (Ec.44).			
Setting range	Setting	Meaning	
0 Bit	10 Bit	Adjust "0" for single-turn encoders.	
1...13 Bit		Number of bits of the multiturn part	

4.1.5 Encoder 1 SSI mode (Ec.54)

Parameter		r/w	Enter	prog.
Ec.54	Encoder 1 SSI mode	yes	yes	no
The SSI interface can be set to special encoder types with this parameter.				
Setting range	Setting	Meaning		
0	0	Default setting for multiturn and single-turn encoders.		
1		Evaluation of single-turn encoders with 25 bit. The data word length of Ec.53 + Ec.44 is not effective here.		
2		Evaluation of linear encoders (e.g. Siko AE111)		

efesotomasyon.com



Karl E. Brinkmann GmbH

Försterweg 36-38 • D-32683 Barntrup
fon: +49 5263 401-0 • fax: +49 5263 401-116
net: www.keb.de • mail: info@keb.de

KEB worldwide...

KEB Antriebstechnik Austria GmbH

Ritzstraße 8 • A-4614 Marchtrenk
fon: +43 7243 53586-0 • fax: +43 7243 53586-21
net: www.keb.at • mail: info@keb.at

KEB Antriebstechnik

Herenveld 2 • B-9500 Geraardsbergen
fon: +32 5443 7860 • fax: +32 5443 7898
mail: vb.belgien@keb.de

KEB Power Transmission Technology (Shanghai) Co.,Ltd.

No. 435 QianPu Road, Songjiang East Industrial Zone,
CHN-201611 Shanghai, P.R. China
fon: +86 21 37746688 • fax: +86 21 37746600
net: www.keb.cn • mail: info@keb.cn

KEB Antriebstechnik Austria GmbH

Organizační složka
K. Weise 1675/5 • CZ-370 04 České Budějovice
fon: +420 387 699 111 • fax: +420 387 699 119
net: www.keb.cz • mail: info.keb@seznam.cz

KEB Antriebstechnik GmbH & Co. KG

Wildbacher Str. 5 • D-08289 Schneeberg
fon: +49 3772 67-0 • fax: +49 3772 67-281
mail: info@keb-combidrive.de

KEB España

C/ Mitjer, Nave 8 - Pol. Ind. LA MASIA
E-08798 Sant Cugat Sesgarrigues (Barcelona)
fon: +34 93 897 0268 • fax: +34 93 899 2035
mail: vb.espana@keb.de

Société Française KEB

Z.I. de la Croix St. Nicolas • 14, rue Gustave Eiffel
F-94510 LA QUEUE EN BRIE
fon: +33 1 49620101 • fax: +33 1 45767495
net: www.keb.fr • mail: info@keb.fr

KEB (UK) Ltd.

6 Chieftain Business Park, Morris Close
Park Farm, Wellingborough GB-Northants, NN8 6 XF
fon: +44 1933 402220 • fax: +44 1933 400724
net: www.keb-uk.co.uk • mail: info@keb-uk.co.uk

KEB Italia S.r.l.

Via Newton, 2 • I-20019 Settimo Milanese (Milano)
fon: +39 02 33535311 • fax: +39 02 33500790
net: www.keb.it • mail: kebtalia@keb.it

KEB Japan Ltd.

15-16, 2-Chome, Takanawa Minato-ku
J-Tokyo 108-0074
fon: +81 33 445-8515 • fax: +81 33 445-8215
mail: info@keb.jp

KEB Korea Seoul

Room 1709, 415 Missy 2000
725 Su Seo Dong, Gang Nam Gu
ROK-135-757 Seoul/South Korea
fon: +82 2 6253 6771 • fax: +82 2 6253 6770
mail: vb.korea@keb.de

KEB RUS Ltd.

Krasnokazarmeny proezd 1,
Metrostation „Aviamotornay“
RUS-111050 Moscow / Russia
fon: +007 445 695 3912 • fax: +007 495 645 3913
mail: info@keb.ru

KEB Sverige

Box 265 (Bergavägen 19)
S-43093 Hälsö
fon: +46 31 961520 • fax: +46 31 961124
mail: vb.schweden@keb.de

KEB America, Inc.

5100 Valley Industrial Blvd. South
USA-Shakopee, MN 55379
fon: +1 952 224-1400 • fax: +1 952 224-1499
net: www.kebamerica.com • mail: info@kebamerica.com

More and newest addresses at <http://www.keb.de>

© KEB	
Mat.No.	DSF5ZEM-K010
Rev.	1E
Date	01/2009