

COMBIVERT

CE

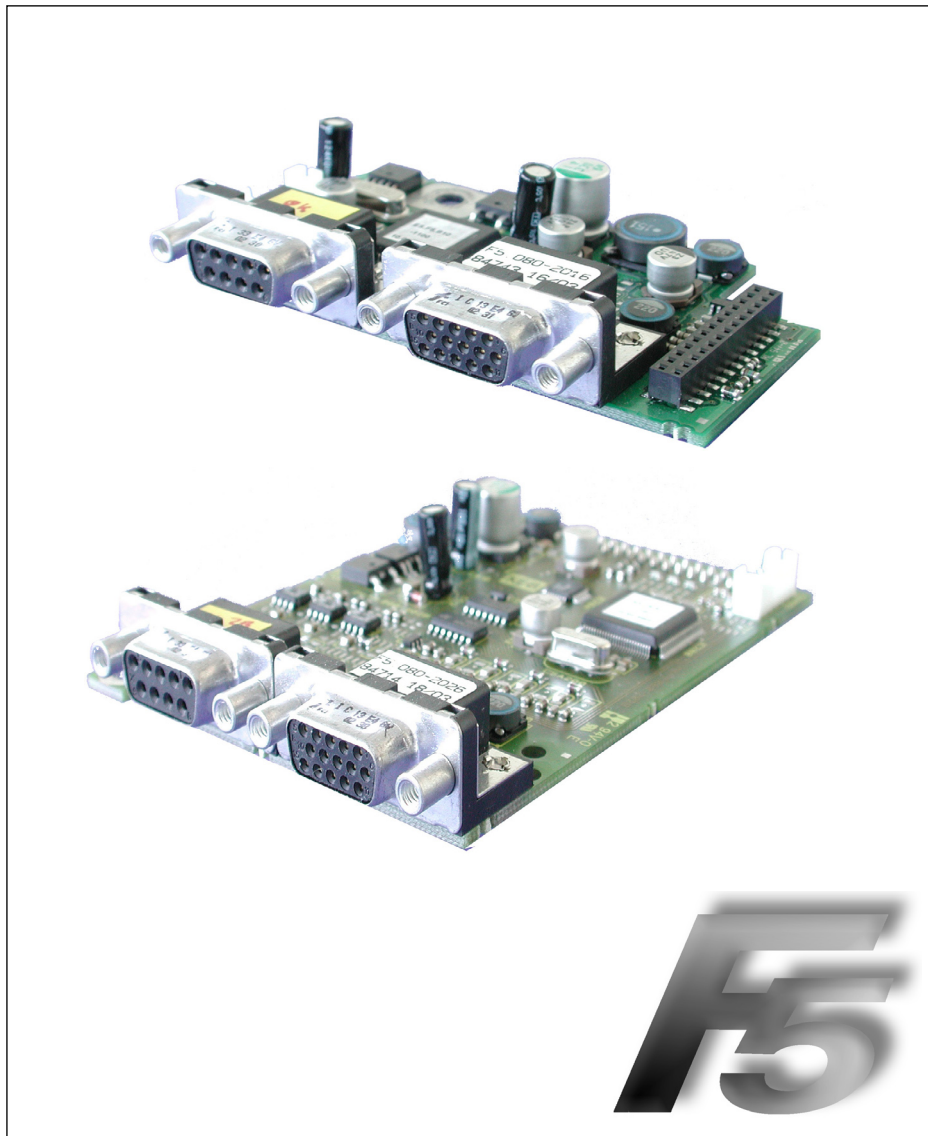

GB INSTRUCTION MANUAL

Channel 1
Channel 2

Encoder Interface

Hiperface
variable

Mat.No.	Rev.
DHF5ZEM-K002	1D



1. Safety Instructions	4
1.1 Validity	4
1.2 Qualification.....	4
2. Product Description.....	5
2.1 General.....	5
2.2 Material number	5
2.3 Scope of delivery (option or replacement delivery)	5
2.4 Mechanical installation	6
3. Description of the Interface	6
3.1 Voltage supply	6
3.2 Channel 2	6
3.3 Channel 1	7
3.3.1 Specifications	7
3.3.2 Description of X3A.....	7
3.3.3 Input signals channel 1.....	8
3.3.3.1 Process data channel.....	8
3.3.3.2 Description of encoder signals	8
3.3.3.3 Encoder breakage recognition	8
3.3.4 Connection of the encoder	9
3.3.4.1 Encoder cabel at SUB-D15	9
3.3.5 Encoder cable	9
3.3.6 Encoder line length.....	10
3.3.7 Tested encoder.....	10
4. Start-up	10
4.1 Hiperface® - Parameter	11
4.1.1 Encoder 1 status (Ec.37).....	11
4.1.2 Hiperface encoder status	12
4.1.3 Read/write Encoder 1 (Ec.38).....	12

1. Safety Instructions

Prior to performing any work on the unit the user must familiarize himself with the unit. This includes especially the knowledge and observance of the safety and warning directions. The pictographs used in this Instruction Manual have following meaning:



Danger Refers to danger of life by electric current.



Warning Refers to possible danger of injury or life.



Note Refers to tips and additional information.

1.1 Validity

The information contained in the technical documentation, as well as any user-specific advice in spoken and written and through tests, are made to best of our knowledge and information about the application. However, they are considered for information only without responsibility. This also applies to any violation of industrial property rights of a third-party.

Inspection of our units in view of their suitability for the intended use must be done generally by the user. Inspections are particularly necessary, if changes are executed, which serve for the further development or adaptation of our products to the applications (hardware, software or download lists). Inspections must be repeated completely, even if only parts of hardware, software or download lists are modified.



Controlling by the user Application and use of our units in the target products is outside of our control and therefore lies exclusively in the area of responsibility of the user.



Use under special conditions

The used semiconductors and components of KEB are developed and dimensioned for the use in industrial products. If the KEB COMBIVERT is used in machines, which work under exceptional conditions or if essential functions, life-supporting measures or an extraordinary safety step must be fulfilled, the necessary reliability and security must be ensured by the machine builder.

1.2 Qualification

All operations serving transport, installation and commissioning as well as maintenance are to be carried out by skilled technical personnel (observe IEC 364 or CENELEC HD 384 or DIN VDE 0100 and national accident prevention rules!). According to this manual qualified staff means:

- those who are able to recognise and judge the possible dangers based on their technical training and experience
- those with knowledge of the relevant standards and who are familiar with the field of power transmission (VDE 0100, VDE 0160 (EN 50178), VDE 0113 (EN 60204) as well as the appropriate regulations for your area.



Danger by high voltage

KEB electronics components contain dangerous voltages which can cause death or serious injury. In operation, drive converters, depending on their degree of protection, may have live, uninsulated, and possibly also moving and hot surfaces.

In case of inadmissible removal of the required covers, of improper use, wrong installation or maloperation, there is the danger of serious personal injury and damage to property.

2. Product Description

Figure 1: Hiperface at channel 1	
2MF5280-2028 /-2029	1MF5280-2028 /-2029
X3B Channel 2 variable see material number	X3A Channel 1 Hiperface

2.1 General

Each of the interface cards delivered by KEB include two interfaces. As there are numerous different combinations available each interface will be described by means of separate instructions. The instruction covers the installation of the interface card, the connection as well as the start-up of a suitable encoder. Further information and the parameter adjustments are described in the application manual for the inverter/servo.

2.2 Material number

xM	F5	K8G	X	X	X	X
Term of delivery			0	installed	Z	Option, spare part
			F	TTL-Output	2029	I TTL-Input 2028
			F5	Series		
applicable for housing size			1M	D, E (circuit board 1MF5280-xxxx see above)		
			2M	G...U (circuit board 2MF5280-xxxx see above)		

2.3 Scope of delivery (option or replacement delivery)

- encoder interface
- two instruction manuals
- fixing bolt
- packing material

2.4 Mechanical installation

All kind of works on the inverter may be carried out by authorized personnel in accordance with the EMC and safety rules only.

- Switch inverter de-energized and await capacitor discharge time
- Pull off operator
- Remove plastic cover
- Remove fixing bolt
- Fix interface board beginning from the socket connector straightly
- Screw in fixing bolt
- Attach plastic cover

3. Description of the Interface

3.1 Voltage supply

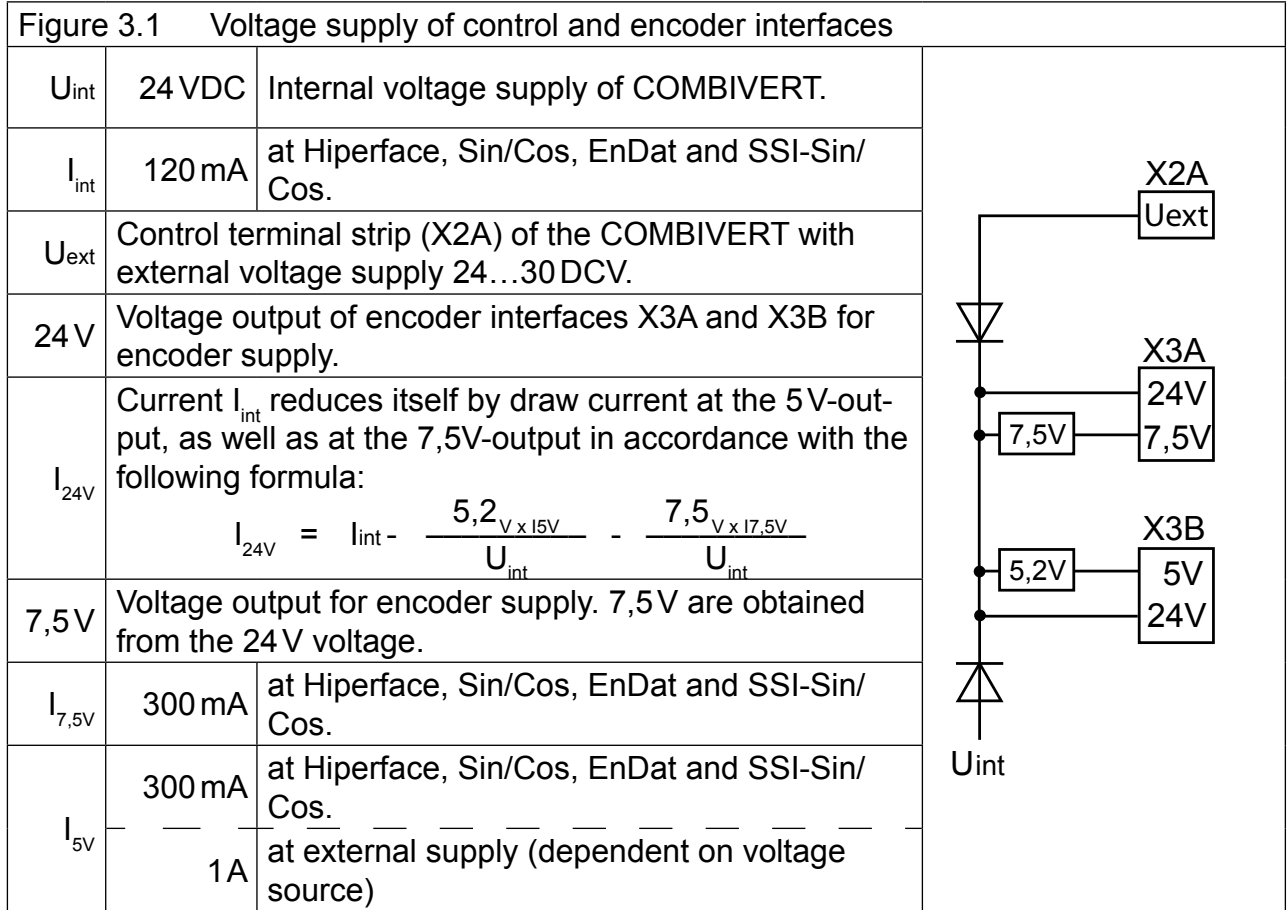

3.2 Channel 2

The description of input X3B is depending on the used encoder interface. It is described in a separate manual.

3.3 Channel 1

3.3.1 Specifications

X3A	Socket SUB-D15
Interface type	Hiperface®
Parameter channel	EIA RS485 half duplex
Process data channel	1 Vss typical (0,6...1,2V)
Limiting frequency	200 kHz
Increments per revolution	1...2048 Ink
Input resistance	120 Ω

3.3.2 Description of X3A

Figure 3.3.2 Socket X3A

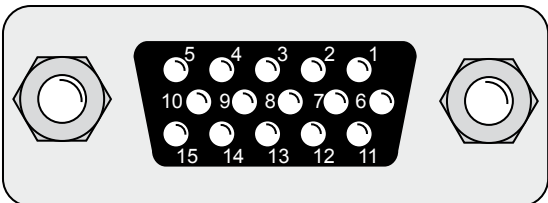

Attention! Plug connector only when COMBIVERT and supply voltage are switched off!

PIN	Name	Description
1	–	–
2	–	–
3	REF_COS	Signal offset to COS+
4	REF_SIN	Signal offset to SIN+
5	–	–
6	–	–
7	–	–
8	COS+	Incremental signal COS for counter and direction detection
9	SIN+	Incremental signal SIN for counter and direction detection
10	+7,5 V	Power supply for encoder
11	+24 V	Voltage output
12	–	–
13	COM	Reference potential for supply voltage
14	Data-	Data channel RS485-
15	Data+	Data channel RS485+
–	GND	Connection for shield at connector housing - is directly connected with the inverter earth. Connect-up external shield at the respective connector housing.

3.3.3 Input signals channel 1

3.3.3.1 Process data channel

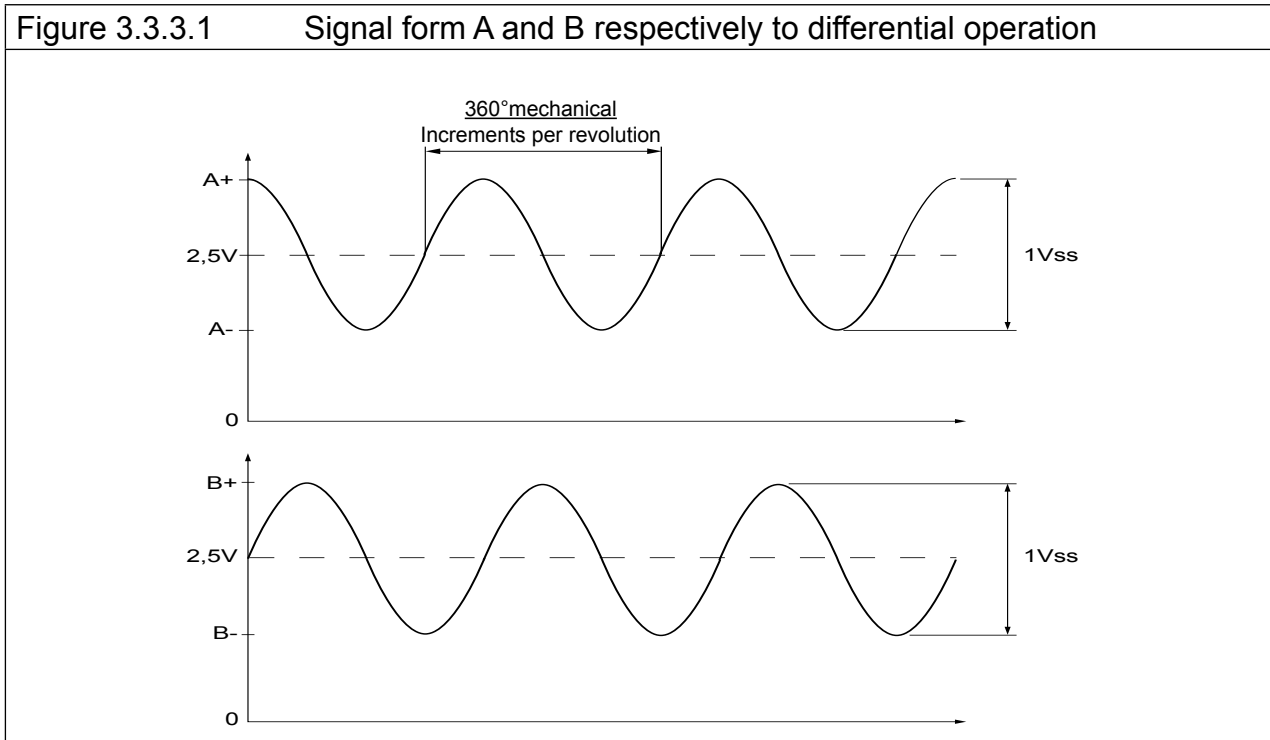

3.3.3.2 Description of encoder signals

During start-up an inquiry is permanently sent to the encoder and the absolute position is serial read out. Thus approach to reference point is not necessary.

As the increments per revolution are stored in the encoder, error Ec.37=70 is triggered immediately, if a deviating value is entered in Ec.1.

A position difference is tracked after filter with ramp time. If this difference increases to quickly, so that it cannot keep tracked or a max. value is exceeded (e.g.at encoder breakage), the interface state Ec.37 changes to „69“ and the inverter switches off.

3.3.3.3 Encoder breakage recognition

The recognition of encoder breakage is a software function and dependent on the encoder type. By writing on Ec.0 the initialization starts. After fault-free initialization the correct position will be send.

The incremental track is monitored approx. all 16 ms. An error is triggered, if the permissible signal levels are fallen below. Also the absolute track, i.e. the serial communication to the encoder is monitored. If the encoder gives not an answer, or a communication is not possible, the respective state message will be transmitted to the inverter. Dependent on the encoder type the response time can be 100 ms and more.

3.3.4 Connection of the encoder

3.3.4.1 Encoder cable at SUB-D15

- Encoder cable double-shielded and twisted in pairs
- Connect exterior shielding at both ends to PE/GND
- Connect interior shieldings at one side to COM
- Don't interconnect exterior and interior shielding

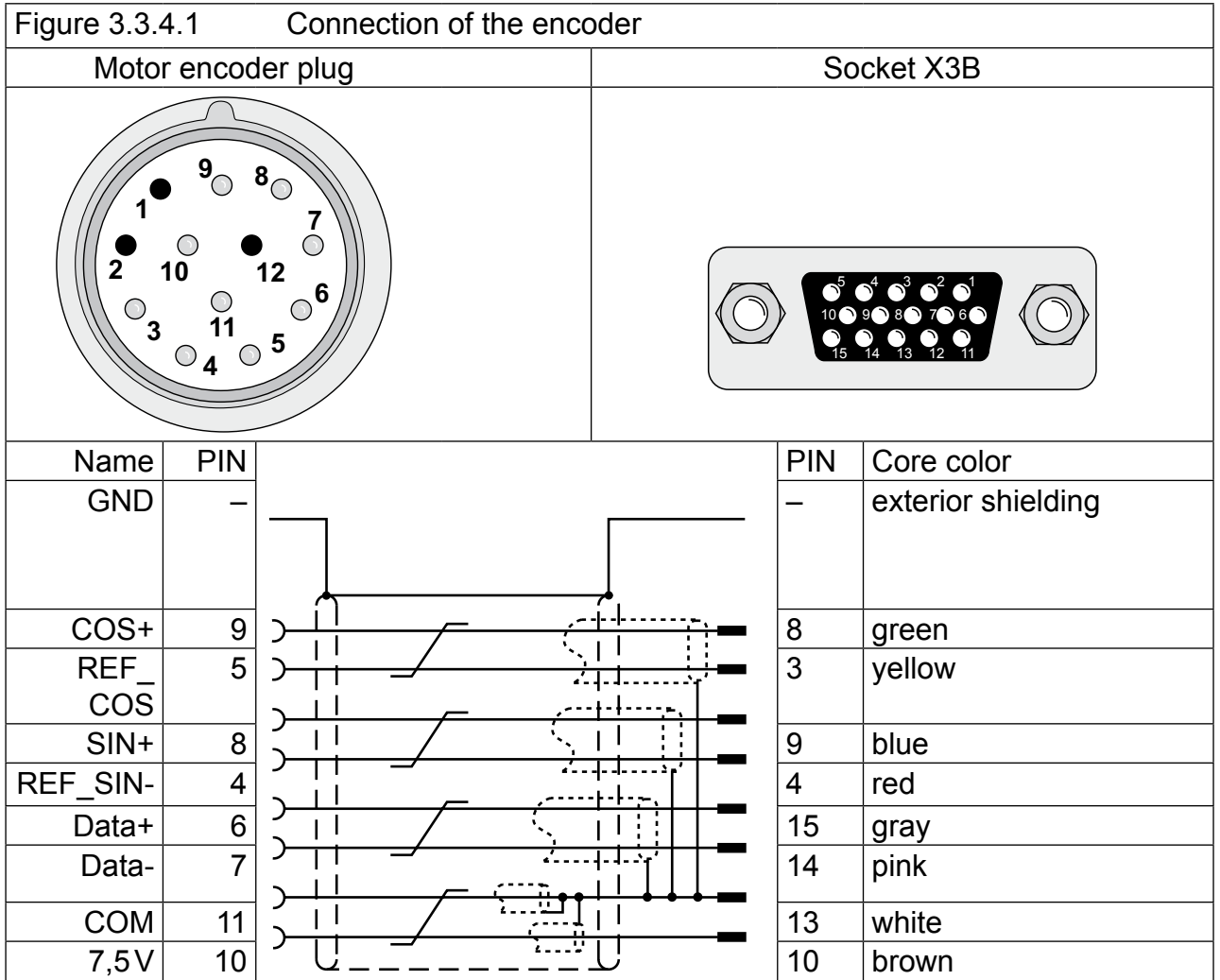

3.3.5 Encoder cable

KEB encoder cables are corresponding to the following specification:

Signal lines	3 x (2 x 0,14 mm ²)
Supply lines	2 x (0,5 mm ²)
Particularities	trailing capable, oil resistant
Temperature range	constant up to 80 °C
Color	green RAL 6018

3.3.6 Encoder line length

The maximum line length of the encoder cable is 50 m. In addition the maximum line length of the connection line is limited by the signal frequency, cable capacity and the line resistance.

Encoder line length =	$\frac{U - U_{\min}}{I_{\max} \cdot 2 \cdot R}$
max. encoder current I_{\max} :	see encoder description
Supply voltage U:	7,5V
min. supply voltage U_{\min} :	see encoder description
KEB encoder cable resistance R:	0,036 Ω /m at 0,5 mm ²

3.3.7 Tested encoder

The following encoders have been tested by KEB on it application:

Encoder description	Hiperface identifier (Ec.36)
SCS 50/60	02h
SCM 50/60	07h
SRS 50/60	22h
SRM 50/60	27h
SKS 36	32h
SKM 36	37h
SEK 52	42h

However, this does not restrict the use of rotary encoder with same specifications of other manufacturers.

4. Start-up

After the installation or exchange of an encoder interface some adjustments of the inverter/servo software have to be done before operation:

- Switch on inverter
- Select application mode
- When using synchronous motors set ud.2 to F5-S
- Select parameter Ec.0 and control whether „Hiperface“ is entered. The displayed value has to be confirmed by „ENTER“ in any case.
- Select parameter Ec.10 and carry out the same for the 2. encoder interface
- Select parameter Ec.1 and control/adjust the increments per revolution
- Select parameter Ec.36 and control if the right encoder type is recognized.
- Select parameter Ec.38; if automatic read in is not adjusted in Bit 2, read out encoder data with Bit 0.
- Select parameter Ec.37 and control encoder status.

4.1 Hiperface® - Parameter

The following parameters are stored in the Hiperface®-encoder and automatically read in or manually read/write by Ec.38:

Synchronous motors: dr.23...dr.28, dr.30...32

Asynchronous motors: dr.0...dr.7

Encoder parameter: Ec.1...3, In.31...32

Controller parameter: cS.19

4.1.1 Encoder 1 status (Ec.37)

This parameter displays, by means of different status messages, the status of encoder and interface. Dependent on the encoder only special messages are possible. All errors are only set at control release, although they are already displayed in Ec.37.

Value	Description
The following value is displayed at correct operation:	
16	Position values are being transferred, encoder and interface are working
The following status messages triggers „Error Encoder Change“ (E.EncC) because the correct evaluation of the position is no longer guaranteed. Error E.EncC can only be reset via parameter Ec.0. Exception! An error due to wrong increments per revolution (value 70) is reset immediately, if the correct increments per revolution are adjusted (from software 2.7). Attention, the modulation is released, when the control release is still set!	
64	Encoder is unknown and will not be supported
67	The signals of the incremental track are not correct, e.g. no encoder is connected or the encoder cable is defective.
68	The signals of the absolute track are not correct. The absolute track at Endat, Hiperface and SSI-Sin/Cos is digital. The absolute track at Sin/Cos is analog.
69	Position deviation too high. The position determined by the incremental signals and the absolute position (of absolute track, zero signal or serial selected) does no longer correspond or cannot be corrected.
70	Increments per revolution adjusted in the inverter does not correspond with encoder increments per revolution.
71	Interface type is unknown: Interface has not been recognized.
75	Encoder temperature too high (message from encoder)
76	Rotary speed too high (message from encoder)
77	Encoder signals are outside the specification (message from encoder)
78	Encoder has internal defect (message from encoder)
92	Encoder will be formatted. When writing an encoder with memory structures different from the KEB-definition, their memories will be re-organized in such a manner that they can be written. This procedure can take some seconds, depending on the respective memory structure.
96	New value detected, because another encoder was attached.
98	Interface is busy

further on next page

Value	Description
The following status messages triggers „Error Encoder 1“ (E.Enc1), if encoder data is read:	
97	KEB-reference is undefined. Memory structure of the encoder does not correspond to the KEB-definition and therefore data cannot be read. The encoder is defined by writing data. At F5-S the error is reset as follow: <ul style="list-style-type: none"> • writing a position to Ec.2. • perform a system position trimming
Following status messages trigger error „Error Hybrid“ (E.HYb):	
0,255	No communication between interface and control card.
The following error/status messages are directly derived from the encoder.	
≥128	Evaluation of the errors in accordance with chapter 4.1.2.

4.1.2 Hiperface encoder status

The most important messages of the Hiperface encoder status are implemented in parameter Ec.37. All other messages can be determined indirectly with Ec.37, if a value ≥ 128 is output.

$$\text{Hiperface encoder status} = \text{Ec.37} - 128$$

The Hiperface encoder status is described in the encoder manual.

Example: Ec.37 = 135; Hiperface encoder status = $135 - 128 = 17$

According to the encoder manual this value has the meaning „indicated address outside data field“. Some messages of the Hiperface encoder status are directly indicated from Ec.37 (e.g. speed too high).

4.1.3 Read/write Encoder 1 (Ec.38)

With Ec.38 the parameter are read/write from/to the encoder.

Bit	Value	Function
0	1	Reading out of the parameters. Then the parameter is reset.
1	2	Storing of the parameters in the encoder (only with supervisor-password and in nOP status)
2	4	Automatic reading out of the parameters when connecting a new encoder (loading after acknowledgement with Ec.0 and default values)

At F5-S bit 2 is default-moderately set, not at F5-M and F5-G. Thus at F5-S encoder data are reading out after default loading.



Karl E. Brinkmann GmbH

Försterweg 36-38 • D-32683 Barntrup
fon: +49 5263 401-0 • fax: +49 5263 401-116
net: www.keb.de • mail: info@keb.de

KEB worldwide...

KEB Antriebstechnik Austria GmbH

Ritzstraße 8 • A-4614 Marchtrenk
fon: +43 7243 53586-0 • fax: +43 7243 53586-21
net: www.keb.at • mail: info@keb.at

KEB Antriebstechnik

Herenveld 2 • B-9500 Geraadsbergen
fon: +32 5443 7860 • fax: +32 5443 7898
mail: vb.belgien@keb.de

KEB Power Transmission Technology (Shanghai) Co.,Ltd.

No. 435 QianPu Road, Songjiang East Industrial Zone,
CHN-201611 Shanghai, P.R. China
fon: +86 21 37746688 • fax: +86 21 37746600
net: www.keb.cn • mail: info@keb.cn

KEB Antriebstechnik Austria GmbH

Organizační složka
K. Weise 1675/5 • CZ-370 04 České Budějovice
fon: +420 387 699 111 • fax: +420 387 699 119
net: www.keb.cz • mail: info.keb@seznam.cz

KEB Antriebstechnik GmbH & Co. KG

Wildbacher Str. 5 • D-08289 Schneeberg
fon: +49 3772 67-0 • fax: +49 3772 67-281
mail: info@keb-combidrive.de

KEB España

C/ Mitjer, Nave 8 - Pol. Ind. LA MASIA
E-08798 Sant Cugat Sesgarrigues (Barcelona)
fon: +34 93 897 0268 • fax: +34 93 899 2035
mail: vb.espana@keb.de

Société Française KEB

Z.I. de la Croix St. Nicolas • 14, rue Gustave Eiffel
F-94510 LA QUEUE EN BRIE
fon: +33 1 49620101 • fax: +33 1 45767495
net: www.keb.fr • mail: info@keb.fr

KEB (UK) Ltd.

6 Chieftain Business Park, Morris Close
Park Farm, Wellingborough GB-Northants, NN8 6 XF
fon: +44 1933 402220 • fax: +44 1933 400724
net: www.keb-uk.co.uk • mail: info@keb-uk.co.uk

KEB Italia S.r.l.

Via Newton, 2 • I-20019 Settimo Milanese (Milano)
fon: +39 02 33535311 • fax: +39 02 33500790
net: www.keb.it • mail: kebtalia@keb.it

KEB Japan Ltd.

15-16, 2-Chome, Takanawa Minato-ku
J-Tokyo 108-0074
fon: +81 33 445-8515 • fax: +81 33 445-8215
mail: info@keb.jp

KEB Korea Seoul

Room 1709, 415 Missy 2000
725 Su Seo Dong, Gang Nam Gu
ROK-135-757 Seoul/South Korea
fon: +82 2 6253 6771 • fax: +82 2 6253 6770
mail: vb.korea@keb.de

KEB RUS Ltd.

Krasnokazarmeny proezd 1,
Metrostation „Aviamotornay“
RUS-111050 Moscow / Russia
fon: +007 445 695 3912 • fax: +007 495 645 3913
mail: info@keb.ru

KEB Sverige

Box 265 (Bergavägen 19)
S-43093 Hälsö
fon: +46 31 961520 • fax: +46 31 961124
mail: vb.schweden@keb.de

KEB America, Inc.

5100 Valley Industrial Blvd. South
USA-Shakopee, MN 55379
fon: +1 952 224-1400 • fax: +1 952 224-1499
net: www.kebamerica.com • mail: info@kebamerica.com

More and newest addresses at <http://www.keb.de>

© KEB	
Mat.No.	DHF5ZEM-K002
Rev.	1D
Date	01/2009