

1. Product Description

1.1 Order designation

Description	Material number
EtherCAT AI4 (Thermo / 16Bit)	00C6CC1-1100
EtherCAT AI8 (Thermo / 16Bit)	00C6CC1-1200
Plug 18-pole for in-/outputs (accessories)	0090501-7121
Grounding assembly 2x8 mm (accessories)	00C6CD1-0400
Grounding assembly 14 mm (accessories)	00C6CD1-0500

1.2 Application

Four or eight analog inputs for temperature detection

1.3 Description of the modules

Picture 1.3 Frontal view of the bus coupler

1.	Release lever			
2.	Status-LED's module			
	EtherCAT	Flash code	Description	
		red - continuous light	Initialisation (Init), no data exchange	
		red/green 1:1	Ready for operation (Pre-Op), no data exchange	
		red/green 3:1	Safe operation (Safe-Op), inputs are readable	
		green - continuous light	Normal operation (Op), full data exchange	
	I/O	Flash code	Description	
		green - cont. light	OK, no error available	
		off	Module defective, if EtherCAT-LED in operation no function, if EtherCAT-LED off	
		Red, 4 x	Response monitoring EtherCAT	
		Red, 6 x	Module specific error	
		Red, 7 x	Configuration error (EtherCAT-Bus in Pre-Op state), number of process data different to the module	
		red - cont. light	Module defect	
3.	I/O-LED's			
	State	Flash code	Description	
	On	green constant	Channel is active	
	off	off	Channel is deactivated	
	Error	red	Measuring range overrange	
4.	Connection I/O (see plug chapter 1.1)			
5.	Earth-/shield connection for bolt M3x5			
6.	E-Bus / module locking			
	Use shielded cables for the analog line and fit the shield on to the purposed place.			
	Connect the DIN mounting rail or the earthing connection with functional earth.			

1.4 Technical data

Fieldbus	EtherCAT 100 Mbit/s
WxHxD	25x120x90 mm
Assembling	35 mm DIN mounting rail
Controller	ASIC ET1200
Connection E-bus	10-pole system connector in side panel
End module	not necessary
Voltage supply	from the EtherCAT coupler by the E-Bus connector
E-Bus load	150 mA
Potential separation	Modules each other and against the bus
Storage temperature	-25 °C...+70 °C
Operation temperature	0 °C...+55 °C
Relative humidity	5%...95% without condensation
Degree of protection	IP20
Noise immunity	Zone B

AI4 thermo element	
Analog inputs	4
Resolution	16 Bit
Measuring range Type K	-200 °C...+1372 °C (resolution 0,1 °C)
Measuring range mV	-40...+65 mV (resolution 2 µV)
Transformation frequency	7.63 Hz (4 channels)
E-Bus load	150 mA

AI8 thermo element	
Analog inputs	8
Resolution	16 Bit
Measuring range Type K	-200 °C...+1372 °C (resolution 0,1 °C)
Measuring range mV	-40...+65 mV (resolution 2 µV)
Transformation frequency	3.82 Hz (8 channels)
E-Bus load	170 mA

1.5 Assembling

Picture 1.5 Mounting of the bus coupler

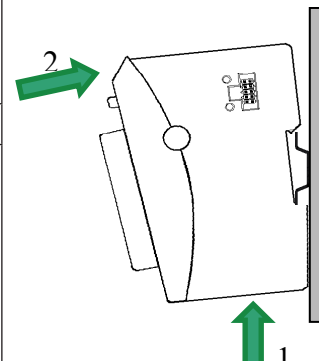
1.	Put the module in accordance with the picture from downside against the mounting rail that the metal spring is impressed between mounting rail and mounting surface.	
2.	Press the module against the mounting panel above until it is snapped-in.	

1.6 Connection of the analog inputs

Connection of AI4-TE with plug 0090501-7121

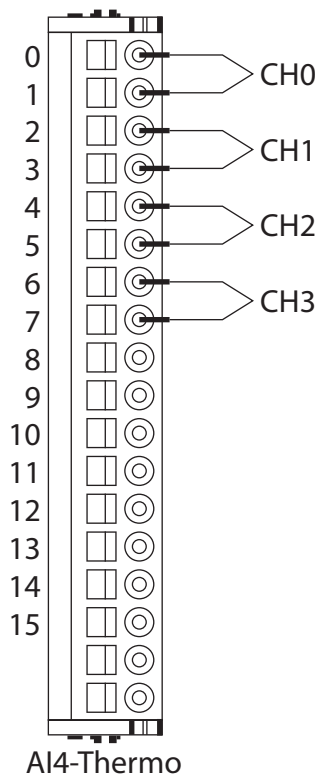

Connection of AI8-TE with plug 0090501-7121

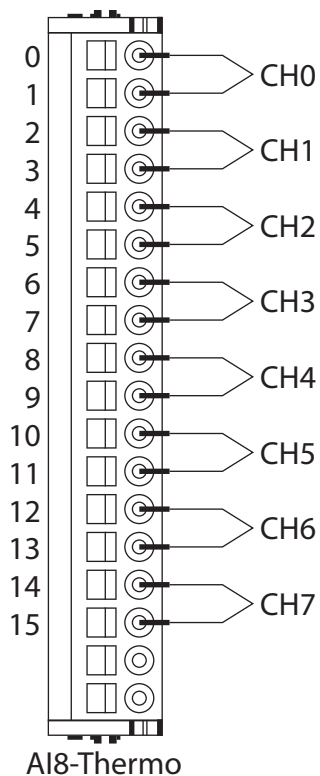

efesotomasyon.com



Karl E. Brinkmann GmbH
Försterweg 36 - 38 • D - 32683 Barntrop
Telefon 0 52 63 / 4 01 - 0 • Telefax 4 01 - 116
Internet: www.keb.de • E-mail: info@keb.de

Mat.No.	00C6NEM-CC50
Rev.	1B
Date	01/2010