

efesotomasyon.com

The right drive for your **Lift**

Elevator

Ascensore

电梯

Elevador

Ascenseur

エレベーター

ЛИФТ

Asensör

Lift

Ascensor

DIANTI

HISS

COMBIVERT Lift

F5

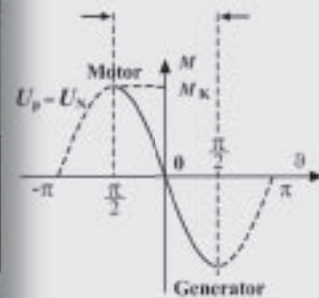

KEB

Lift - History

1987

1st generation of IGBT-inverters, type **58**
LSVF-inverter for OTIS, Berlin

1991



2nd generation of lift-inverters type **F2** with vector-controller, distributed in Europe by SIEMENS

1992

1st planetary-gear-drive with high efficient industrial motor and KEB-two-circuit-fail-safe-brake for LM-Munich

1996



3rd generation of lift-inverters type **F4**
with flux vector control
Development of regenerative units, type **R4**

1997

Two elevators with planetary-gear-drive running 3 m/s at CARLSBERG Brewery, Denmark and LVM insurance Münster, Germany

1998

Lift-servo-parameters for permanent-magnet-gearless-motors

2000

Special customer software for the US-market
Six elevators in Malaysia with asynchronous-gearless-machine at a speed of 3,5 m/s

2001

First elevators with new inverter-generation type **F5** in open-loop

2002

New F4 controlboard for Hiperface-encoders
Software version V3.0 for high-torque-pm-motors

2003

First elevators 2,5 m/s with positioning control, direct approach

2005



4th generation of Lift-inverters
F5-Lift with positioning controller, **all in one**
Development of THD-filters according to the EN 12015

2006

Elevator with **F5** positioning controller and direct approach at a speed of 5 m/s
2nd generation of regenerative units, type **R6**



Hardware

- varnished boards against environmental influences (dust, etc.)
- high modulation frequency for noiseless operation
- perfect load-transfer when the brake opens
- power-range from 0,25 kW up to 710 kW
- disconnection under load allowed
- thermostatic controlled fan, no noise when lift is not in use
- 220 V AC single-phase power supply for emergency-run with UPS
- detection of the "easy direction" for undersized UPS
- small dimensions



305 V ... 500 V 3phase

Inverter	Motor Power kW	Nominal Current A	Peak Current (30s) / A
10.F5.A1D-3A0A	2,2	5,8	10,4
12.F5.A1D-3A0A	4	9,5	17
13.F5.A1D-390A	5,5	12	21,6
14.F5.A1E-3A0A	7,5	16,5	29,7
15.F5.A1E-350A	11	24	36
16.F5.A1G-360A	15	33	49,5
17.F5.A1G-350A	18,5	42	63
18.F5.A1G-340A	22	50	75
20.F5.A1H-380F	37	75	135
21.F5.A1R-960A	45	90	135
22.F5.A1R-960A	55	115	172
23.F5.A1R-940A	75	150	225
24.F5.A1R-940A	90	180	270

Further sizes upon request!

Software

- self optimizing operating menu
- easy diagnosis
- parameter in lift-terminology
- protection against wrong adjustment
- easy adjustment
- multi encoder
- open-loop-vector-control
- multi motor
- special digital in- and output functions like:
 - brake control
 - main contactor
 - UPS function
 - level running open doors
- speed curve with 5 independent jerks and different acceleration and deceleration for shortest floor-to-floor-times for best driving comfort and optimized passenger conveyance
- direct approach with correction input or positioning control
- self optimizing only with motor-nameplate-data and winding resistance
- speed setting via digital inputs, analog inputs, via BUS, or positioning control
- ogive function with automatic correction of deceleration-curve

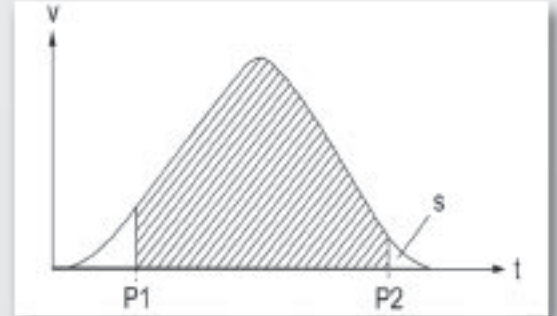

Safety features:

- Encoder failure detection
- Over-current detection
- Over-voltage detection
- Brake opening check
- Over speed fault
- Speed limitation whilst inspection-, levelling- and relevelling-speed
- Healing of encoder-puls-loss and encoder-puls-excess
- Output phase check
- Under-voltage detection
- Speed deviation detection
- Main contactor check
- Powerless switching of main contactors

Diagnostic / Adjustment Tools

- Fault history, fault counters, peak current and peak voltage values
- Parameters to view the I/O status, analog input voltages, output voltage, output frequency, output current, motor torque, DC bus voltage
- Diagnostic parameter for trouble shooting encoders with serial communication.
- KEB COMBIVIS PC Software for monitoring and programming the F5 Elevator Drive.

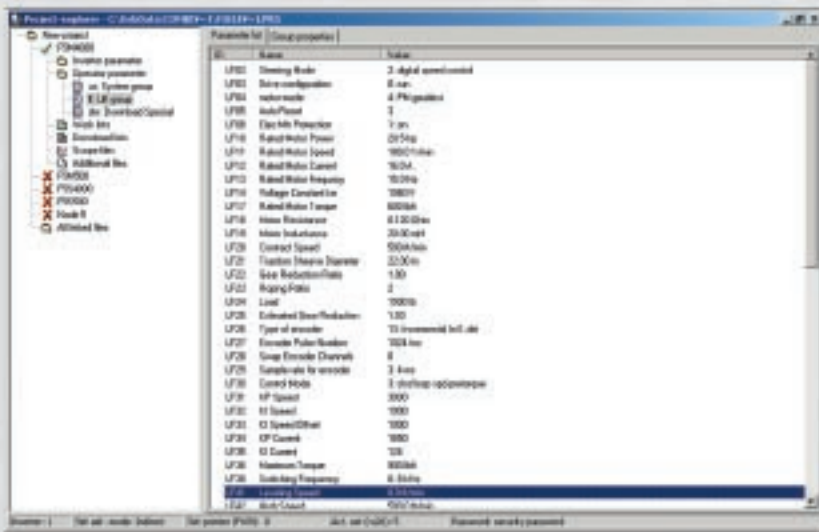

All parameters can be quickly viewed and adjusted through a parameter explorer. Complete drive set up can be saved to disk or copied to another drive for fast commissioning of multiple cars.

Scope function allows adjuster to view realtime operation of the elevator drive.

Typical parameters to monitor are: commanded speed, actual speed, motor current and motor torque. Additionally, analog input and output signals, digital inputs and outputs, drive temperature, DC bus voltage, output voltage, encoder position, ...and many more, can be monitored.

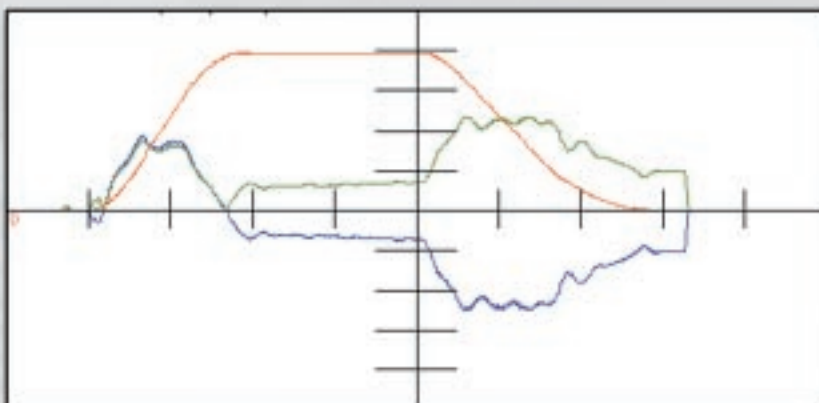

Open Loop

The ideal solution for retrofitting old elevators and keeping the existing machine.

Your advantages:

- Maintains constant speed in both up and down, loaded and unloaded conditions
- Good positioning, load independent, ± 1 mm
- Easy adjustment, self tuning only by setting the motor-nameplate-data and measuring the winding resistance (can be measured by the inverter drive after installation)
- Digital input for brake release check
- Digital input for main contactor check
(verifies the contactor is switching between each run)
- Saves installation costs
- Main contactor output to control the contactor and provide powerless switching of the contactor
- Speed-and current-regulator-values are self adjusting
- Works even with old high slip ($> 10\%$) two speed motors
- Positioning controller still works, even when running the motor open loop, uses a position sensor in the hoistway instead.
- Output-phase check before brake opening and during the run for maximum safety

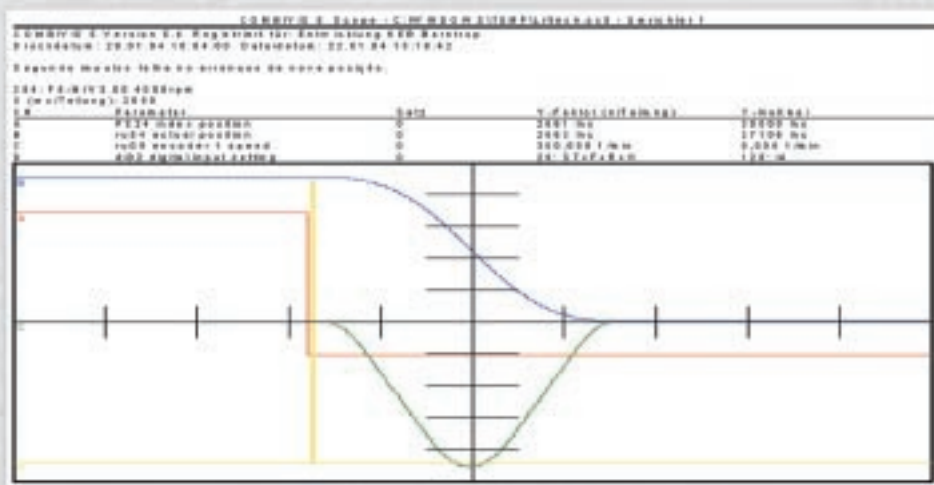
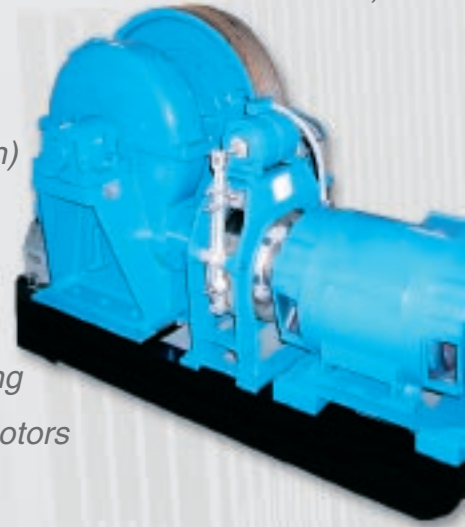

Example: positioning using hoistway encoder but without motor encoder

flexibility

Closed Loop

By installing a feedback interface card the F5 Elevator Drive is ready for closed loop operation. With these feedback cards it is possible to control **both AC induction as well as permanent magnet, synchronous motors.**

The options are as follows:

- Incremental **TTL, HTL**, with SUB-D connector or plug in screw terminals
- **SinCos** • **Hiperface** • **UVW** • **Resolver** • **EnDat** • **SSI**
- Detection of over speed, and speed following errors
- High speed run and/or deceleration confirmation based on motor speed
- Fast rollback compensation for a smooth transition from brake to motor
- High performance speed regulation, ensures accurate tracking of speed profile.
- Full support of advanced encoder functions (**HIPERFACE, EnDat**), stores motor data, encoder position, etc.
- High resolution encoder interface - supports over 1,000,000 ppr

In addition, KEB can supply pre-manufactured encoder cables. That simplifies field installation and avoids time spending troubleshooting. These high quality cables are made of double shielded twisted pairs for maximum noise immunity.

Special gearless features:

- Special gearless mode - designed to handle the difficulties of low speed operation with higher speed resolution (0.015 rpm), greater internal value resolution, optimized control loops and gain values
- Exceptional load transfer from brake to motor with permanent magnet motors, accurate load weighing is often not required
- High bandwidth speed and current loop - compensates torque ripples often found in inexpensive PM gearless motors



Ogive

- for different floor-to-floor distances
- self-adaption of deceleration
- teach in of deceleration-distance "S1" or manual setting
- scan time of correction input = 256 μ s for precise correction
- ogive, direct approach, correction before landing

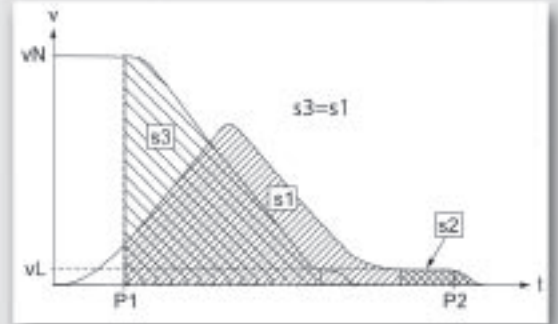

Position control is the latest development to help the elevator control manufacturer to reduce the overall system costs. Naturally, some of these savings are also relevant for the contractor.

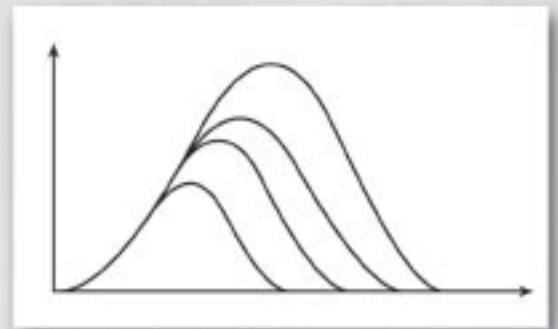

easy



- more comfortable
- more precise
- easy and time saving commissioning
- direct approach with and without motor encoder
- input for shaft encoder, incremental or SSI
- for old and new lift machines
- for asynchronous or synchronous motors
- travel time optimizing speed profile
- new floor-selection whilst running

Braking Resistors

- noiseless
- less radiation
- with temperature sensor

efesotomasyon.com



Inverter	BR Part Number	R (Ohm)	PD (W)	PS (W)	A (mm)	B (mm)	C (mm)	D/D' (mm)	E (mm)
10.F5-D	11.BR.100-6180	180	190	3200	26	240	80	-	225
12.F5-D	13.BR.100-6110	110	350	5000	28	400	80	-	385
13.F5-D	14.BR.226-7853	85	600	12000	270	625	116	240/176	526
14.F5-E	16.BR.226-7423	42	1200	15000	270	625	116	240/176	526
15.F5-E	16.BR.226-7423	42	1200	15000	270	625	116	240/176	526
16.F5-G	17.BR.226-6303	30	1200	19000	270	625	116	240/176	526
17.F5-G	18.BR.226-6203	20	1700	29000	270	625	116	240/176	526
18.F5-G	19.BR.226-6153	15	2300	38000	270	625	116	240/176	526
20.F5-H	21.BR.226-6103	10	3400	53000	270	625	223	240/176	526
21.F5-R	22.BR.226-6866	8,6	4000	68000	270	625	273	240/176	526
22.F5-R	23.BR.226-6676	6,7	5200	86000	270	625	273	240/176	526
23.F5-R	24.BR.226-6506	5	6900	115000	270	625	223	240/176	526
24.F5-R	25.BR.226-6436	4,3	8100	135000	270	625	273	240/176	526

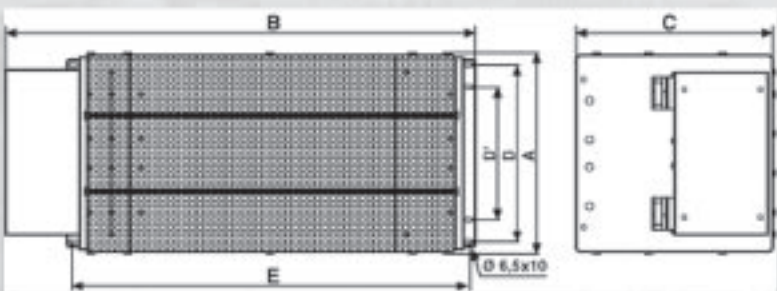
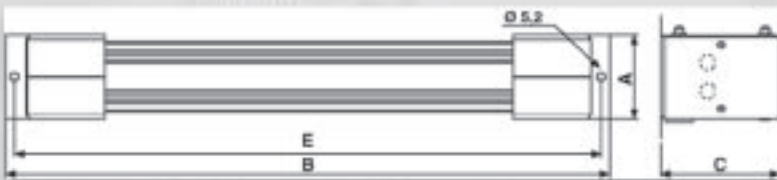

Number of modules

= 2-fold

EMC-Service

- means mobile assistance on site
- advice in the planning phase
- analysis of existing systems

is one way in which we can help design real system solutions.

The EU-guidelines 90/336/EEG place on every machine manufacturer the obligation to carry out the installation of electrical plants according to the EMC-regulation.

In many cases the task arises to check the interplay of individual CE-marked components in the plant or the machine



For this purpose KEB offers a service which includes the consultation as well as the testing of electrical installations. The long experiences in development and application of drive controllers in the various branches of industry, combined with modern mobile measuring devices, provide optimal conditions for a fast support on the spot.

HF-Filters

Inverter	Filter Kit Part Number	Power Loss (W)	Leakage Current (mA)	EMC-level / cable lenght	Dimensions W x H x D (mm)	Weight (kg)
10.F5-D	10.U5.B0D-3020	7	15	B / 30m	90 x 250 x 40	1.3
12.F5-D	13.U5.B0D-3020	11.5	20	B / 30m	90 x 250 x 40	1.3
13.F5-D	13.U5.B0D-3020	11.5	20	B / 30m	90 x 250 x 40	1.3
14.F5-E	14.U5.B0E-3030	14	4	B / 10m	135 x 355 x 50	1.5
15.F5-E	15.U5.B0E-3030	21	4	B / 10m	135 x 355 x 50	1.5
16.F5-G	17.U5.B0G-3030	14	11	B / 10m	180 x 415 x 55	3.2
17.F5-G	17.U5.B0G-3030	14	11	B / 10m	180 x 415 x 55	3.2
18.F5-G	18.U5.B0G-3030	20	7	B / 10m	180 x 415 x 65	5.1
20.F5-H	20.U5.B0H-3000	30	15	B / 30m	270 x 445 x 75	5.5
21.F5-R	23.U5.B0R-3000	60	48	B / 30m	270 x 400 x 65	9
22.F5-R	23.U5.B0R-3000	60	48	B / 30m	270 x 400 x 65	9
23.F5-R	23.U5.B0R-3000	60	48	B / 30m	270 x 400 x 65	9
24.F5-R	23.U5.B0R-3000	60	48	B / 30m	270 x 400 x 65	9

Filter sizes of 10 to 18 are particularly suitable for IT-mains



- EMC-filters according to EN 12015 and optimized for elevator drives
- Special designs for a delta connected supply
- Low ground leakage currents < 11 mA

Tidy Technology

KEB has long been involved in these developments starting with special EMC filters, active power factor correction, and now finally to harmonic mitigation. We can offer a complete range of filter products to meet these specifications world wide.



Harmonic mitigation according to the new guideline EN 12015 from March 2005

- Small physical size due to special core design
- Optimized for use with back up power generators
- Protects the drive from voltage transients
- Increases drive lifetime
- no fan - no noise
- further series THD $\leq 8\%$ and PWHD $\leq 15\%$ available

Harmonic Filter- THD $\leq 15\%$ / PWHD $\leq 38\%$

Part number	I_{rating} [A]	A [mm]	B [mm]	C [mm]	weight [kg]
07.Z1.C04-1001	2.4	148	134	163	2.6
10.Z1.C04-1001	6.1	178	128	168	4.8
12.Z1.C04-1001	10	175	145	220	6.8
13.Z1.C04-1001	12.6	220	155	250	8.7
14.Z1.C04-1001	17.3	243	185	260	12.2
15.Z1.C04-1001	25.2	267	171	285	16.3
16.Z1.C04-1001	34.7	291	205	275	22.6
17.Z1.C04-1001	44.1	291	215	280	27
18.Z1.C04-1001	52.5	316	256	300	33
19.Z1.C04-1001	63	316	242	297	35.8

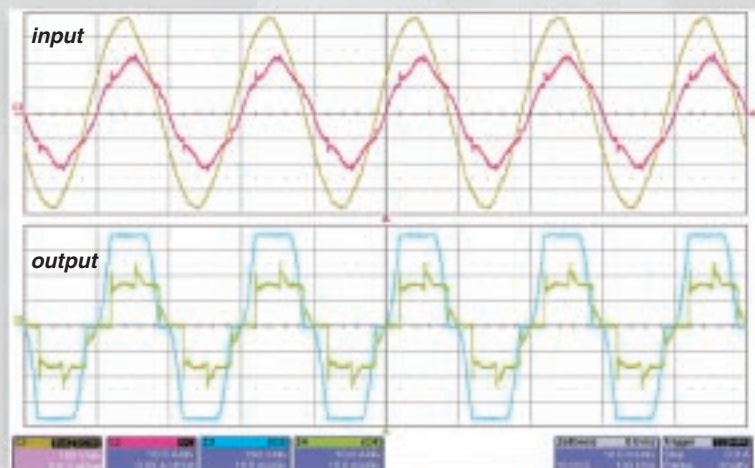
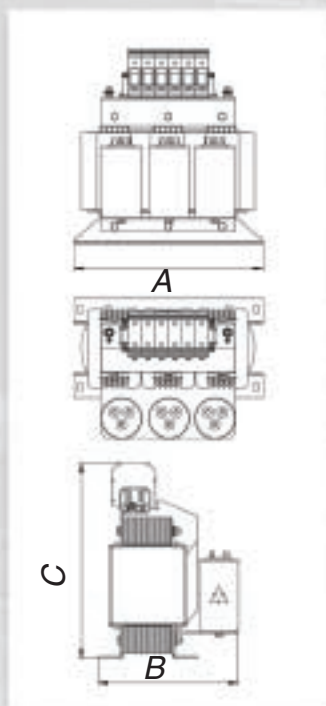

Voltage and current with harmonic filter THD $\leq 8\%$

Regenerative Units

The physical principle of all elevators is to change electrical energy into potential energy that is stored in the load which was lifted up.

In 50 % of all rides the motor works as a generator and gives back the potential energy. Typically this energy is changed into heat by braking resistors.

This heat is wasted in the machinery room and often needs additionally energy for air-condition.

After 10 years experience in regen units KEB introduces the next generation for faster amortisation.

Advantages:

- Energy savings - returns overhauling load energy back to the line supply.
- High regen system efficiency - greater than 98%, minimal lost energy on return.
- Modular sizes - to match the up front investment with the required demand, i.e. a gearless system will have more returned energy than a geared, therefore a gearless system would need a larger regen module.
- Elimination of the braking resistors - the size of the cooling (HVAC) system for the machine room can be reduced, offsetting the up front cost of the regen system. Furthermore, the operating cost of the cooling system is reduced.
- Competitive compatibility - the KEB regen system can be used not only with KEB elevator drives but also with those of our competition. Get the same benefit even when you use a different drive.
- No decrease in power quality - the base KEB regen system creates the same level of harmonic distortion on the line, as does a standard drive without regen.
- EN 12015 compliant - when using a KEB harmonic filter together with the KEB regen system the result is a solution which meets the requirements of EN 12015 and IEEE519 for power quality.
- Easy to install - nothing to adjust, simply turn it on and it runs when the elevator does.
- User interface - display & keypad for diagnostic service, COMBIVIS software can also be used to graph performance.

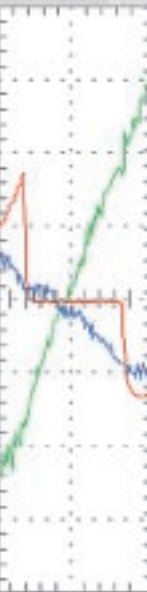

green line
red line
blue line

Elevator Brakes COMBISTOP

Type 38.DDN / Double brake

Type 38.DEN / Single brake

Type D8 / redundant single brake



- brake for Lift application with TÜV approval, conform to EN 81
- low noise < 60dB!
- also as safty-device on gearless-machines to avoid safty-gear for direction upwards
- type D8 - two armature parts at one magnet, TÜV approval for sizes 05, 07 and 09
- much less inertia as a drum brake



Construction features:

- IP40 - Standard, IP65 / IP66 on request
- Coil IP 66
- housing consists of forging (no shrink hole which shear and scrap especially in the area of springs)
- springs are corrosion protected, refined and fixed, steady stroke consistent 10.000.000 strokes
- other options: flange, hand release, dust protection ring, terminal box
- Encoder / tacho generator adapter

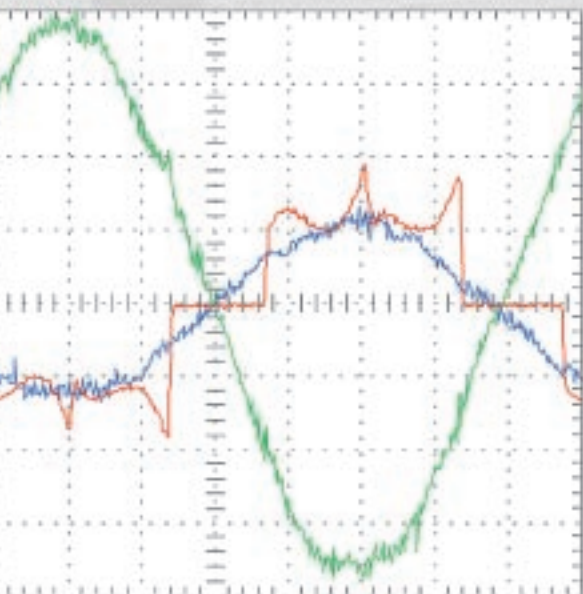

voltage
current
current with harmonic filter

Worldwide

- *support through experienced application engineers*
- *training / seminars*
- *trouble shooting / service*
- *accompanying measurements for EMC-certification*
- *development*
- *engineering*
- *documentation*



Ask for door-drives and escalator drives!



Customized Solutions

- ideal for retrofit
- dust tight
- plug and play

Options:

- HF-filter
- THD-filter
- choke
- main contactors
- brake contactor
- decoupling relays
- prewired

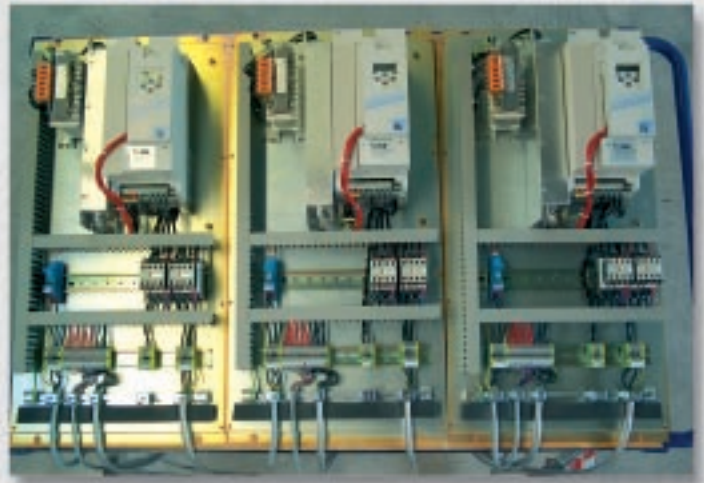

our partners for complete solutions:

- ISA, Germany
- SFKEB, France
- SETEC, Belgium



people in motion



KEB Antriebstechnik Austria GmbH • Ritzstraße 8 • **A** - 4614 Marchtrenk
Tel.: +43 7243 53586-0 • FAX: +43 (0) 7243 53586-21
Internet: www.keb.at • E-Mail: info@keb.at



KEB Antriebstechnik Austria GmbH / Organizacni slozka • K. Weise 1675/5 • **CZ** - 37004 České Budějovice
Tel.: +420 38 76991-11 • FAX: +420 38 76991-19
Internet: www.keb.at • E-Mail: info@seznam.cz



KEB Antriebstechnik • Herenveld 2 • **B** - 9500 Geraardsbergen
Tel.: +32 5443 7860 • FAX: +32 5443 7898
E-Mail: vb.belgien@keb.de



KEB Power Transmission Technology (Shanghai) Co., Ltd - Office Room 401
No. 665 North Songwei Road (New Husong Road), Songjiang District • **CHN** - 201613 Shanghai, P.R. China
Tel.: +86 21 51095995 • FAX: +86 21 54450115 • Internet: www.keb.cn • E-Mail: info@keb.cn



Société Française KEB • Z.I. de la Croix St. Nicolas • 14, rue Gustave Eiffel • **F** - 94510 LA QUEUE EN BRIE
Tél.: +33 1 49620101 • FAX: +33 1 45767495
Internet: www.keb.fr • E-Mail: info@keb.fr



KEB (UK) Ltd. • 6 Chieftain Buisness Park, Morris Close • Park Farm, Wellingborough, **GB** - Northants, NN8 6 XF
Tel.: +44 1933 402220 • FAX: +44 1933 400724
Internet: www.keb-uk.co.uk • E-Mail: info@keb-uk.co.uk



KEB Italia S.r.l. • Via Newton, 2 • **I** - 20019 Settimo Milanese (Milano)
Tel.: +39 02 33535311 • FAX: +39 02 33500790
Internet: www.keb.it • E-Mail: info@keb.it



KEB - Japan Ltd. • 15 - 16, 2-Chome • Takanawa Minato-ku • **J** - Tokyo 108 - 0074
Tel.: +81 33 445-8515 • FAX: +81 33 445-8215
Internet: www.keb.jp • E-Mail: info@keb.jp



KEB KOREA • Representative Office, Room 1709, 415 Missy 2000, 725 Su Seo Dong, Gang Nam Gu
ROK - 135-757 Seoul / South Korea
Tel.: +82 2 6253-6771 • FAX: + 82 (0) 2 6253-6770 • Internet: www.kebkorea.com • E-Mail: vb.korea@keb.de



KEB - RUS Ltd. • Dolgorukovskaja str. 33, Building 8 • **RUS** - 127006 Moscow / Russia
Telefon + 7 499 9723162 • Telefax +7 499 9789573
E-Mail: info@keb.ru



KEB Sverige • Box 265 (Bergavägen 19) • **S** - 43093 Hälsö
Tel.: +46 31 961520 • FAX: +46 31 961124
E-Mail: vb.schweden@keb.de



KEB España • C / Mitjer, Nave 8 Poligono Industrial "La masia" • **E** - 08798 Sant Cugat Sesgarrigues (Barcelona)
Tel.: +34 93 8970268 • FAX: +34 93 8992035
E-Mail: vb.espana@keb.de



KEB America, Inc. • 5100 Valley Industrial Blvd. South • **USA** - Shakopee, MN 55379
Tel.: +1 952 2241400 • FAX: +1 952 2241499
Internet: www.kebamerica.com • E-Mail: info@kebamerica.com



KEB Antriebstechnik GmbH • Wildbacher Str. 5 • **D** - 08289 Schneeberg
Telefon +49 3772 67-0 • Telefax +49 3772 67-281
Internet: www.keb.de • E-Mail: info@keb-combidrive.de

© KEB 00.00.000-5LIF 01/2008 - Subject to technical changes -



Karl E. Brinkmann GmbH
Försterweg 36 - 38 • **D** - 32683 Barntrop
Telefon 0 52 63 / 4 01 - 0 • Telefax 4 01 - 116
Internet: www.keb.de • E-mail: info@keb.de