

## Preface

Thank you for choosing the CHV110 series of injection molding machine energy savers developed by Shenzhen INVT Electric Co., Ltd..

This operating instruction manual must be made available for actual operators of the equipment.

To guarantee the safety of users and to achieve the optimal energy saving effect while satisfying technological requirements of energy savers, please read this operating instruction manual carefully before use.

CHV110 series energy savers are applicable to various injection molding machines with constant delivery pumps under hydraulic transmission control. According to different pressures and rates of flow required for different operational stages of injection molding machines, the user can adjust the output power of the oil pump accordingly to save energy by 25% to 50%. They feature high energy conservation ratio, high reliability, motor soft start, and easy operation.

If you have any problems during use, please contact our technical department.

Please keep this operating instruction manual properly as a reference in future maintenance, repair, and use in a different operating condition.

The company reserves the right to constantly improve its products. Any technical improvement, if without impact on the use of the equipment, shall be made without notice.

## Table of Contents

1. Energy Saving Principle.....	1
2. Product Features.....	2
3. Application Environment.....	3
4. Installation and Configuration.....	4
4.1 Environmental Requirements.....	5
4.2 Outside Dimensions of Energy Saver.....	6
4.3 Connection of Injection Molding Machine with Energy Saver.....	7
4.4 Operation Instructions for Current Signal Acquisition Card.....	10
4.5 Signal Acquisition Method of Injection Molding Machine.....	11
4.6 Description of Operation Panel.....	13
4.7 Operation Procedures.....	15
4.8 Installation and Debugging Procedures.....	21
5. Operating Guide.....	26
5.1 Switchover between Mains Supply Mode and Energy Saving Mode.....	26
5.2 Test Stage.....	26
5.3 Normal Operation Stage of Energy Saver.....	27
6. Fault Diagnosis.....	28
6.1 Fault Diagnosis and Corrective Action.....	28
6.2 Handling of Common Faults.....	32
6.3 Adjustment of Common Product Defects.....	33
7. Repair and Maintenance.....	36
7.1 Daily Check.....	36
7.2 Periodic Check.....	36
8. Warranty.....	38
9. Additional Information.....	39
Attachment 1: List of Functional Parameters.....	40
Attachment 2: Standard Wiring Diagram.....	50
Attachment 3: Warranty Card.....	52

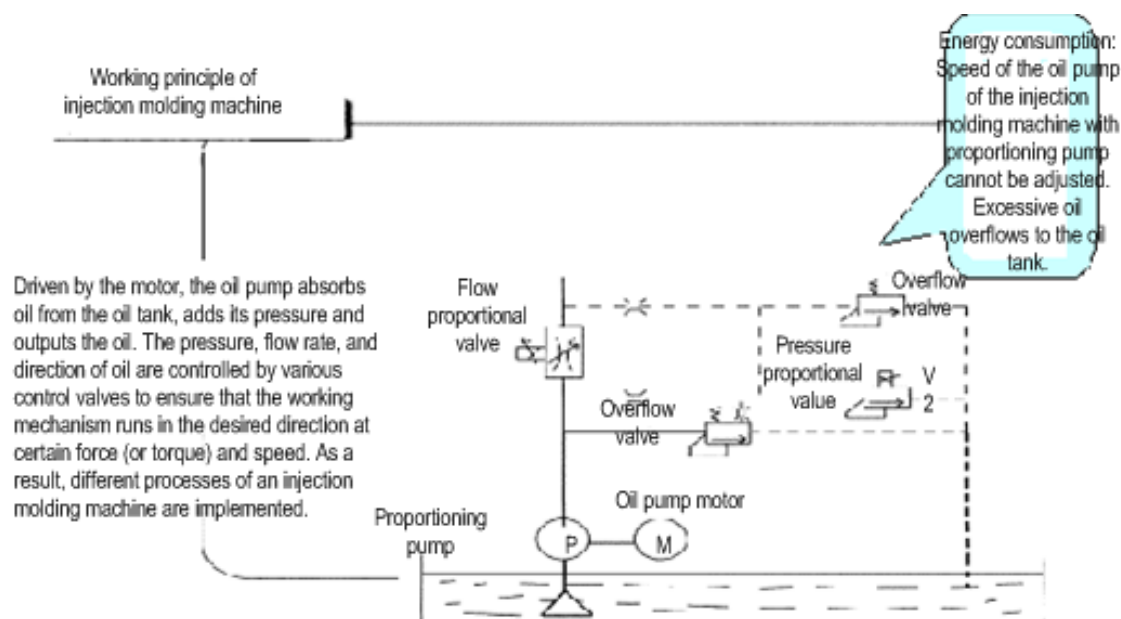

For traditional injection molding machines with constant delivery pumps, valve adjustment is required to change load flow rate and pressure. In this case, input power changes slightly, and a large proportion of energy is consumed by the valve in the form of pressure difference, causing overflow.

CHV110 energy saver can automatically adjust the rotation speed and oil supply quantity of the oil pump based on the current working state of an injection molding machine, like mold clamping, injection, melting, mold opening, and ejector pin, and according to the set pressure and speed requirements, so that the actual oil supply quantity of the oil pump can be consistent with the actual load flow rate of the injection molding machine at any stage. As a result, it minimizes the energy consumption when the motor operates in its load range, eliminates overflow phenomenon, and ensures stable and precise operation of the motor.

Application of CHV110 energy saver makes soft start possible for the motor of injection molding machines, improves the power factor  $\cos \phi$  of the motor, and dynamically adjusts the output power of the motor of injection molding machines. In this way, the energy is saved.



## **Product Features**

---

CHV110 series of products are the latest products launched by Shenzhen INVT Electric Co.,Ltd. based on its years of experience in research, development, production, and on-site rebuilding of energy savers for injection molding machines. The products represent the leading level in the same industry. Compared with existing product, CHV110 series have the following features:

- Fast current limiting function, with an instantaneous impulse current as high as 250% and an overload capability up to 180%/30 seconds; ensuring normal operation under such heavy load as injection and no influence upon the production efficiency; ensuring product quality;
- Automatic reset and power failure reset function, ensuring production continuity and efficiency;
- CHV110 series feature integrated structure and dual power supply switching and control system;
- With a protection grade of IP54, full-closed design, perfect dust-proof, gas-proof, and corrosive-proof performance and strong environment adaptability, prolonging the service life of the equipment;
- Independent air duct design, providing better heat dissipation effect, preventing electrostatic dusts from causing damage to electronic components;
- Small size, easy to install, user-friendly structure design; compact structure, supporting cabinet installation and wall mounting;

To achieve better energy saving effect, the following aspects must be taken into account before carrying out the energy saving rebuilding for injection molding machines:

- 1) Type of injection molding machine: The energy saver is applicable to injection molding machines with hydraulic constant delivery pumps only, and it is not applicable to other types of injection molding machines (such as those with electric or variable delivery pumps).
- 2) Injection molding technology: The energy saving ratio will not reach the lowest rate if the molding period is too short (less than 10 seconds), or most technological parameters of the equipment are close to or up to the full load.
- 3) Equipment condition: For the old model of injection molding machines or those with circuit defects, such problems as large noise and motor overheat may occur when the energy saver is installed.
- 4) Installation environment: It is recommended not to install any other high-precision analog test meters on the same circuit of the energy saver because they may be interfered by the higher-order harmonic.

## Safety Instructions

Please read this operating instruction manual carefully before installing, operating, maintaining or checking the equipment.

Safety information in this manual is divided into “WARNING” and “CAUTION”.

 **WARNING** Indicates potential hazards that, if not avoided, could result in loss of life or serious injury.

 **CAUTION** Indicates potential hazards that, if not avoided, could result in minor or medium injury or damage to the equipment. It can be used to warn unsafe operations. It can be used to warn unsafe operations.

In some cases, even contents described in **CAUTION** may result in major accidents. Therefore, follow these important safety instructions in any cases. Therefore, follow these important safety instructions in any cases.

★ **Note** Procedure taken to ensure correct operation.

Warning signs are marked on the front cover of the inverter.

Follow these instructions when using the inverter.

## Warning Mark

WARNING	
●	May cause injury or electric shock.
●	Please follow the instructions in the manual before installation or operation.
●	Disconnect all power before opening front cover of unit. Wait at least 1 minute until DC Bus capacitors discharge.
●	Use proper grounding techniques.
●	Never connect AC power to output UVW terminals 



## WARNING

- Operation on the component/system of the inverter by untrained personnel or nonobservance of requirements stipulated in the warning may result in severe personal injury or property loss. Only qualified personnel who have received training in equipment design, installation, debugging and operation can work on the component/system of the equipment.
- Power feeding line can only be permanently connected and the equipment must be securely grounded.
- Even when the inverter is disabled, the following terminals may have dangerous voltage:
  - Power terminals R, S, T
  - Terminals to be connected to the motor: U, V, W
- After the power switch is turned off, wait at least 5 minutes before installation so that the inverter is completely discharged.
- The minimum sectional area of the grounding conductor must be equal to or greater than that of the power supply cable.



## Caution

- Hold the base to lift the cabinet. Do not hold the panel to move the inverter. Otherwise, the main unit may fall off and may result in personal injury.
- Install the inverter on fire-retardant materials (such as metal); otherwise, it may result in fire.
- To install two or more inverters in a cabinet, it is necessary to install a cooling fan to keep the air temperature below 45°C; overheat may result in fire or damage to the equipment.

## 4.1 Environmental Requirements

Energy savers have good heat dissipation performance. To ensure high performance and long service life of energy savers, follow the suggestions below when selecting an installation site.

- Keep a clearance between the energy saver and adjacent articles.
- The energy saver shall be prevented from rain and direct sunshine when it is located close to a window; otherwise, it may result in equipment damage.
- The equipment shall be protected from mechanical impact or vibration;
- It is recommended to operate the equipment in the temperature range -10°C to 40°C.

Excessively high or extremely low temperature may lead to equipment fault.

- The surrounding shall be free of electromagnetic interference and the equipment shall be kept at a distance away from any interference source;
- Flammables, thinners and solvents shall be kept far away from the equipment.
- The equipment shall be prevented from dust, oily dust, floating fiber, and metallic particles.
- The equipment shall be installed on a solid base without vibration. It shall be securely fixed if it is mounted on the wall.

## 4.2 Outside Dimensions of Energy Saver

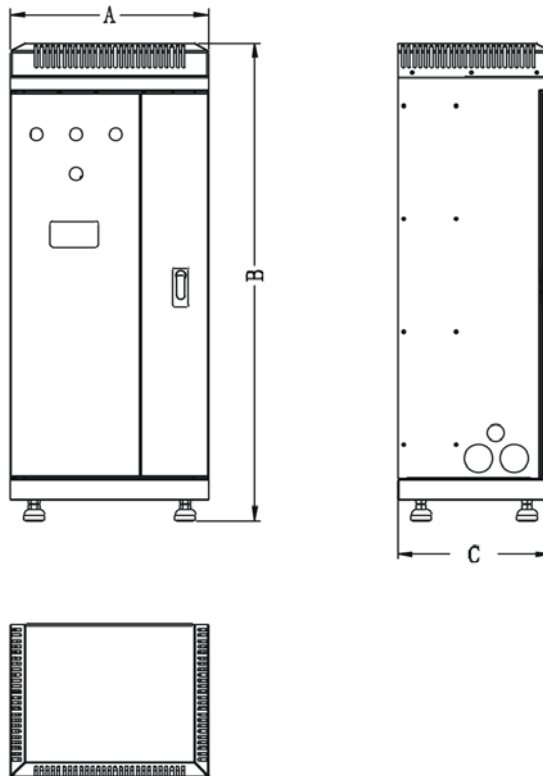

Model and Power Range	A (mm)	B(mm)	C(mm)
	Outside Dimensions		
CHV110-(07R5-015)T3	300	685	250
CHV110-(018-030)T3	350	846	270
CHV110-(037-055)T3	390	935	285
CHV110-075T3	431	985	360



### Warning

- To ensure safe operation of the inverter, only qualified and service-trained electrician can work on the equipment.
- It is strictly forbidden to test the insulation of the cables connected to the inverter with high-voltage insulation testing equipment.
- Even when the inverter is disabled, other power feeding lines, DC loop terminals and motor terminals may have dangerous voltage. Therefore, after the power switch is turned off, wait at least 5 minutes before performing any operation to make sure the inverter is completely discharged.
- The grounding terminal of the inverter must be securely grounded. Grounding resistance for 200V grade shall be 100Ω or lower; Grounding resistance for 400V grade shall be 10Ω or lower; Grounding resistance for 660V grade shall be 5Ω or lower. Nonobservance of this WARNING may result in electric shock or fire.
- Make sure the input terminals (R, S, T) and output terminals (U, V, W) of the inverter are correctly connected; any wrong connection may cause damage to the inverter.
- Never connect the wires or operate the inverter with wet hand; otherwise, it may result in an electric shock.



### CAUTION

- Confirm that the rated voltage of the inverter is consistent with the AC power voltage.
- Power cables and motor cables must be connected securely and permanently.

### 4.3 Connection of Injection Molding Machine with Energy Saver

#### 4.3.1 Schematic diagram of connection of injection molding machine with energy saver

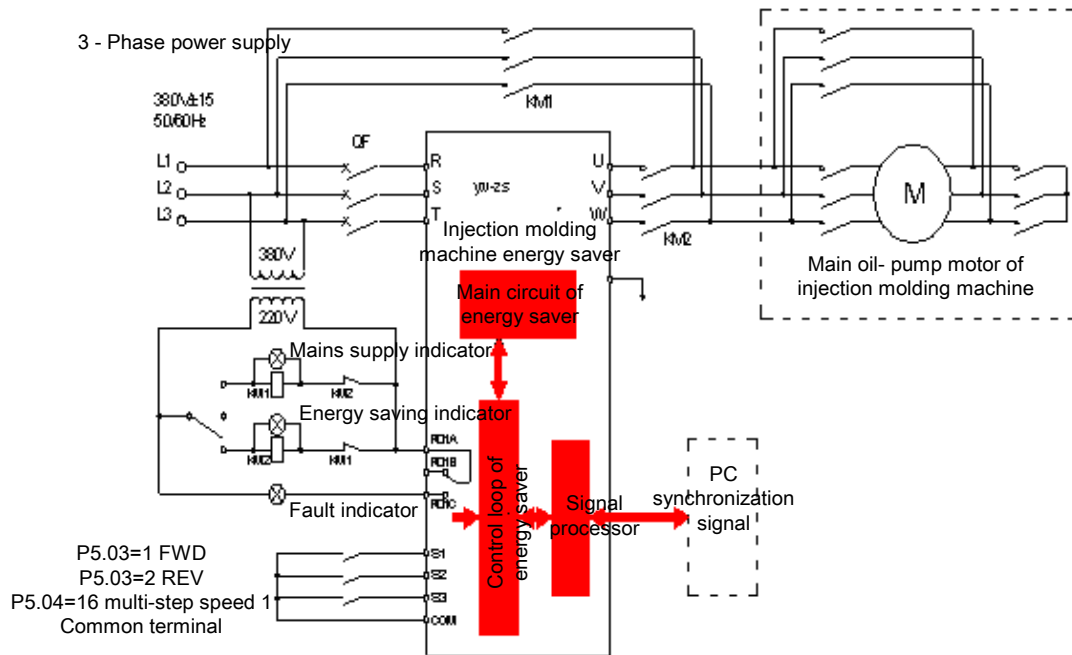

Figure 4.3.1 Schematic Diagram of Connection of Injection Molding Machine to Energy Saver



- To ensure safe operation of the inverter, only qualified and service-trained electrician can work on the equipment.
- It is strictly forbidden to test the insulation of the cables connected to the inverter with high-voltage insulation testing equipment.
- Even when the inverter is disabled, other power feeding lines, DC loop terminals and motor terminals may have dangerous voltage. Therefore, after the power switch is turned off, wait at least 5 minutes before performing any operation to make sure the inverter is completely discharged.
- The grounding terminal of the inverter must be securely grounded. Grounding resistance for 200V grade shall be 100Ω or lower; Grounding resistance for 400V grade shall be 10Ω or lower; Grounding resistance for 660V grade shall be 5Ω or lower. Nonobservance of this WARNING may result in electric shock or fire.
- Make sure the input terminals (R, S, T) and output terminals (U, V, W) of the inverter are correctly connected; any wrong connection may cause damage to the inverter.
- Never connect the wires or operate the inverter with wet hand; otherwise, it may result in an electric shock.



### CAUTION

- Confirm that the rated voltage of the inverter is consistent with the AC power voltage.
- Power cables and motor cables must be connected securely and permanently.

#### 4.3.2 Main loop terminals consist of:

- 1) Three-phase AC power input terminals: R, S, T
- 2) Ground wiring terminal: 
- 3) Motor wiring terminals: U, V, W

Distribution of main loop terminals is shown in Figure 4.3.2

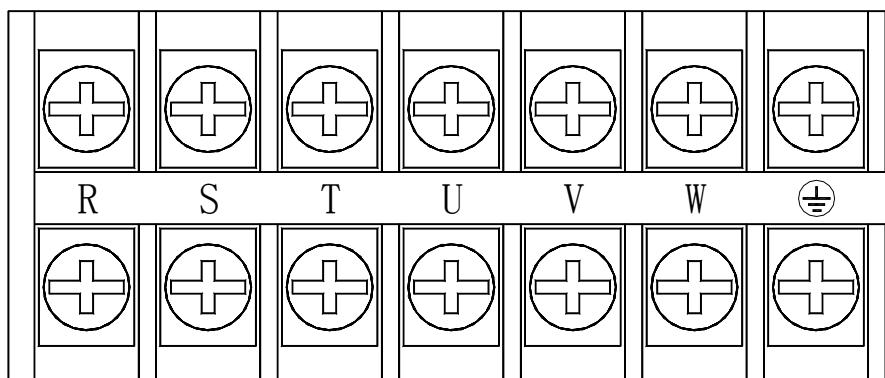

Figure 4.3.2 Main Loop Terminal Block of the Energy Saver for Injection Molding Machine

#### 4.3.3 Terminals of control loop:

S1	S2	S3	S4	S5	HDI1	GND	AI1	AI2	+10V	R01A	R01B	R01C
+24V	PW	COM	Y1	CME	COM	HDO	AO1	GND	PE	R02A	R02B	R02C

Figure 4.3.3 Wiring Terminals of Control Loop

Terminal Name	Purpose and Description
S1~S5	Digital input terminals, forming optical coupling isolation input with PW and COM; Input voltage range: 9~30V Input impedance: 3.3 K $\Omega$
HDI1 (HDI2)	High-speed pulse or digital input, forming optical coupling isolation input with PW and COM; Range of pulse input frequency: 0-50 KHz Input voltage range: 9~30V Input impedance: 1.1 K $\Omega$
PW	External power supply; the user can directly connect it (with COM) or use the +24V power supplied by the equipment. When the inverter is delivered out of the factory, +24V and PW are short-circuited by default. If you use the external power supply, disconnect the +24V power supply.
+24V	+24V power supply provided for the inverter; Maximum output current: 150 mA
COM	Common terminal for +24V or external power supply
AI1 (AI3, AI4)	Analog input, voltage range: 0V~10V Input impedance: 10 k $\Omega$
AI2	Analog input: voltage (0~10V)/current (0~20 mA), optional through J18; Input impedance: 10 K $\Omega$ (voltage input)/250 $\Omega$ (current input)
+10V	+10V power supply provided for the inverter;
GND	Reference zero potential for +10V (Note: GND is isolated from COM)
Y1 (Y2)	Open collector output terminal, with the corresponding common terminal as CME External voltage range: 0~24V Output current range: 0~50 mA
CME	Common terminal for open collector output
HDO	High-speed pulse output terminal, with the corresponding common terminal as COM; Output frequency range: 0~50 KHz
AO1 (AO2)	Analog output terminal: optional voltage or current output through jumper J19; Output range: voltage (0~10V)/current (0~20 mA)
PE	Grounding terminal
RO1A, RO1B, RO1C	RO1 relay output, RO1A common terminal, RO1B normally close, RO1C normally open Contact capacity: AC 250V/3A, DC 30V/1A
RO2A, RO2B, RO2C	RO2 relay output, RO2A common terminal, RO2B normally close, RO2C normally open Contact capacity: AC 250V/3A, DC 30V/1A
RO3A, RO3B, RO3C	RO3 relay output, RO3A common terminal, RO3B normally close, RO3C normally open Contact capacity: AC 250V/3A, DC 30V/1A

### 4.3.4 Composition of pressure and flow signal input terminals

The composition of pressure and flow signal input terminals of the energy saver for injection molding machine is shown in Figure 4.3.4

- 1) Current signal channel 1, 1IA, 1IB
- 2) Current signal channel 2, 2IA, 2IB

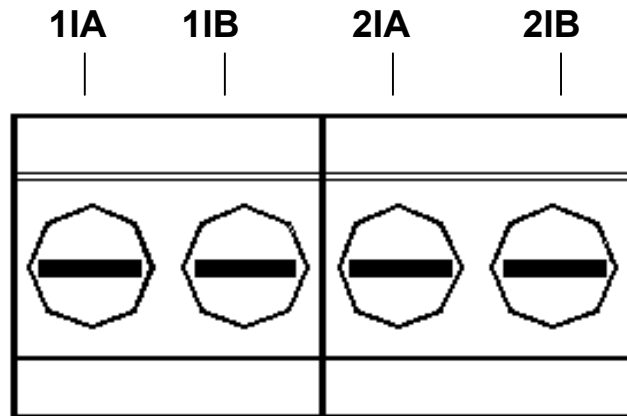

Figure 4.3.4 Pressure and flow (current signal) input terminals

## 4.4 Operating Instructions for Current Signal Acquisition Card

4.4.1. The appearance of the current signal acquisition card is shown in Figure 4.4.1-1.

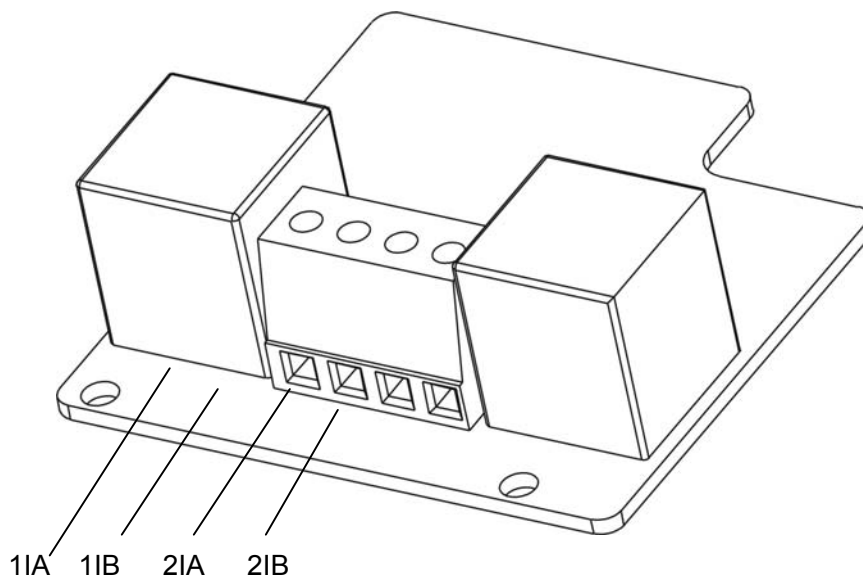

Figure 4.4.4-1 Appearance of Current Signal Acquisition Card

The card has four wiring terminals, as shown in Figure 4.4.4-2.

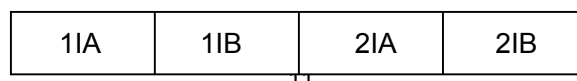

Figure 4.4.4-2 Wiring Terminals

Where, 1IA and 1IB are input terminals of the current signal channel, and the corresponding internal channel is AI3. Its functional code is P0.03=2, and the corresponding parameters are set to P5.25-P5.29. 1IA is the positive input of the differential current, and 1IB is the negative input of the differential current. 2IA and 2IB are input terminals of current signal channel 2, and the corresponding internal channel is AI4. Its functional code is P0.04=1, and the corresponding parameters are set to P5.30-P5.34. 2IA is the positive input of the differential current, and 2IB is the negative input of the differential current. In addition, the combination mode of the two signal channels is set by parameter P0.05. Upon wiring, pay attention to the flow direction of the current over the signal line; otherwise, the inverter cannot operate normally. If any signal is input, the on-board LED will indicate whether the wiring is correct. For the current signal card, if the current signal is greater than 0.6A, the LED will light up, and its brightness will increase with the input signal.

#### 4.4.2 Special Functions

**Functional code P4.12:** If it is set to “0”, it indicates the terminal control command is invalid upon power-up; if it is set to “1”, it indicates that the terminal control command is valid upon power-up.

#### 4.4.3 Precautions on Wiring

- The signal line of the injection molding machine card should be separated from the power line. Parallel wiring is forbidden.
- To prevent injection molding machine signals from interference, please select a shielded cable as the signal line of the injection molding machine card.
- The shielding layer of the shielded signal line cable of the injection molding machine card should be grounded (such as terminal PE of the inverter), and furthermore, only one end is grounded, to prevent signal interference.

### 4.5 Signal Acquisition Method of Injection Molding Machine

To install an energy saver correctly for an injection molding machine, it is necessary to

precisely identify the proportional flow and proportional pressure signals, which serve as input signals for the energy saver. There are three methods as follows:

**Method 1:** Collecting signals from proportional flow and proportional pressure ammeters. Most injection molding machines have these two ammeters. They are usually installed on the panel of or in the distribution box of an injection molding machine. The range of an ammeter is usually 0-1A. To distinguish a proportional flow ammeter from a proportional pressure ammeter, set an action parameter of the injection molding machine to 0 (for flow) or 50 (for pressure) and then perform the action. The ammeter whose pointer moves is the proportional pressure ammeter. The proportional flow ammeter is alike.

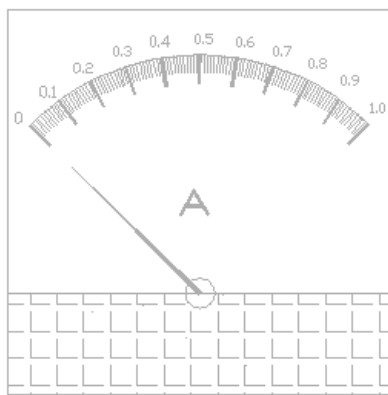

Proportional Flow Ammeter

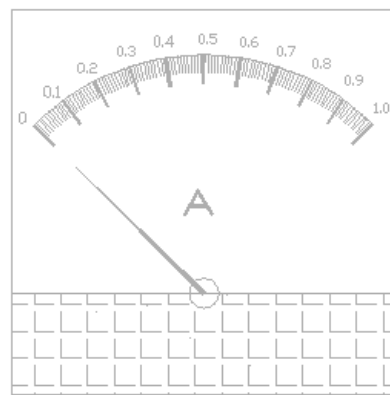

Proportional Pressure Ammeter

**Method 2:** Collecting signals from proportional pressure and proportional flow signal amplifier board. On the signal amplifier board, the user can find power amplification transistors for pressure and flow signals. In other words, the circuit board that has two power transistors is the proportional pressure and proportional flow signal board. Moreover, the first letters of pressure and flow are marked on the wiring terminals of the circuit: pressure (P+, P-) and flow (F+, F-). The user can also determine whether it is proportional pressure or proportional flow signal by the current scale of a multimeter.

**Method 3:** Collecting signals on the proportional pressure and proportional flow solenoid valves. On the oil way block on the both ends of an injection molding machine, there are a number of solenoid valves, most of which are directional valves. Unlike directional valves, the proportional pressure and proportional flow solenoid valves are often combined together and looks much bigger than flow valves. The user can also determine whether they are proportional pressure and proportional flow solenoid valves by the current scale

of a multimeter.

Note: Proportional pressure and flow signals must be 0-1A current signals, and the signal acquisition card must be connected in series with such signals. Proportional pressure and flow signals flow into the signal acquisition card from 11A/21A, and flow out from 11B/21B. If the signal acquisition card is reversely connected, it cannot collect any signals and the injection molding machine has no action signal.

## 4.6 Description of Operation Panel

### 4.6.1 Schematic diagram of operation panel

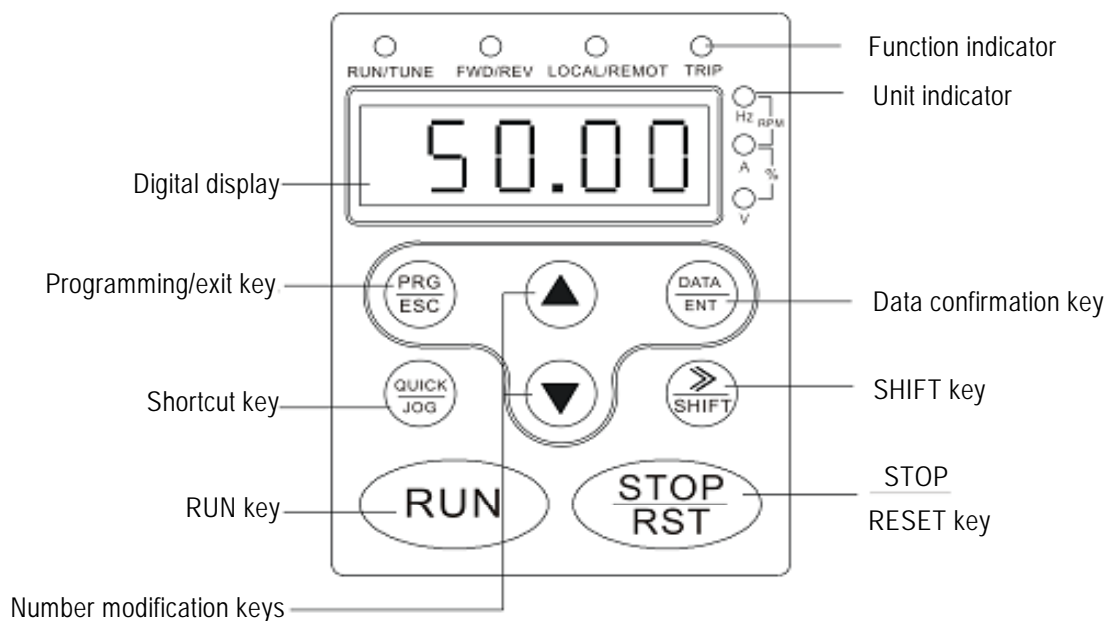



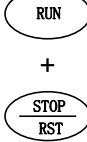

Figure 4.6.1 Schematic Diagram of the Operation Panel

### 4.6.2 Functions of keys

Key Symbol	Name	Function Description
	Programming key	Enters or exits the level-1 menu; deletes shortcut parameter
	Confirmation key	Enters menus level by level; conforms parameter setting
	UP key	Increase of data or functional code
	DOWN key	Decrease of data or functional code

Key Symbol	Name	Function Description
	SHIFT key	Displays parameters cyclically in the stop display interface and operation display interface; select the bit to be modified when modifying a parameter
	RUN key	Used for operation in keypad operation mode
	STOP/RESET key	In operation state, press this key to stop the operation; restricted by the functional code P7.04. In fault alarm state, press this key to reset any control mode.
	Multifunctional shortcut key	Function of this key is determined by the functional code P7.03: 0: Quick function of shortcut menus; enters or exits level-1 menu. 1: Switching between forward rotation and reverse rotation; the changeover key 2. JOG operation, forward rotation JOG key 3. Clearing UP/DOWN settings: Clears frequency values set by UP/DOWN keys
	Combination	Press the <RUN> key and the <STOP/RST> key at the same time, the inverter free stops

#### 4.6.3 Description of Indicators

##### 1) Description of functional indicators

Indicator	Indication
RUN/TUNE	If the indicator is off, it indicates the inverter stops; if the indicator flickers, it indicates the inverter is in the parameter self-learning state; if the indicator is on, it indicates the inverter is in the operation state;
FWD/REV	Forward/Reverse rotation indicator: If the indicator is off, it means the inverter is in the forward rotation state; if the indicator is on, it means the inverter is in the reverse rotation state.
LOCAL/REMOTE	Keypad operation, terminal operation, and remote communication control indicator: If the indicator is off, it indicates the inverter is in the keypad operation control mode; if the indicator flickers, it indicates the inverter is in the operation control state; if the indicator is on, it indicates the inverter is in the remote operation control state.
TRIP	Overload alarm indicator: If it is in the overload alarm state, the indicator flickers; otherwise, the indicator is off.

##### 2) Description of unit indicators

<b>Symbol</b>	<b>Description</b>
Hz	Frequency unit
A	Current unit
V	Voltage unit
RPM	Rotation speed unit
%	Percent

### 3) Digital display area

The 5-digit LED display can display various monitoring data such as set frequency and output frequency as well as alarm code.

## 4.7 Operation Procedures

### 4.7.1 Parameter setting

Three-level menus:

- 1) Functional code group number (level-1 menu);
- 2) Functional code ID (level-2 menu);
- 3) Functional code set value (level-3 menu).

Note: In level-3 menu operation, press <PRG/ESC> or <DATA/ENT> to return to the level-2 menu. The difference between two keys is: if you press <DATA/ENT>, the system saves set parameters in the control board, returns to the level-2 menu, and automatically shifts to the next functional code; if you press <PRG/ESC>, the system directly returns to the level-2 menu without saving the parameter, and still stays at the current functional code.

For example, change the value of the functional code P1.01 from 00.00 Hz to 01.05 Hz.

### **Stop/Run**

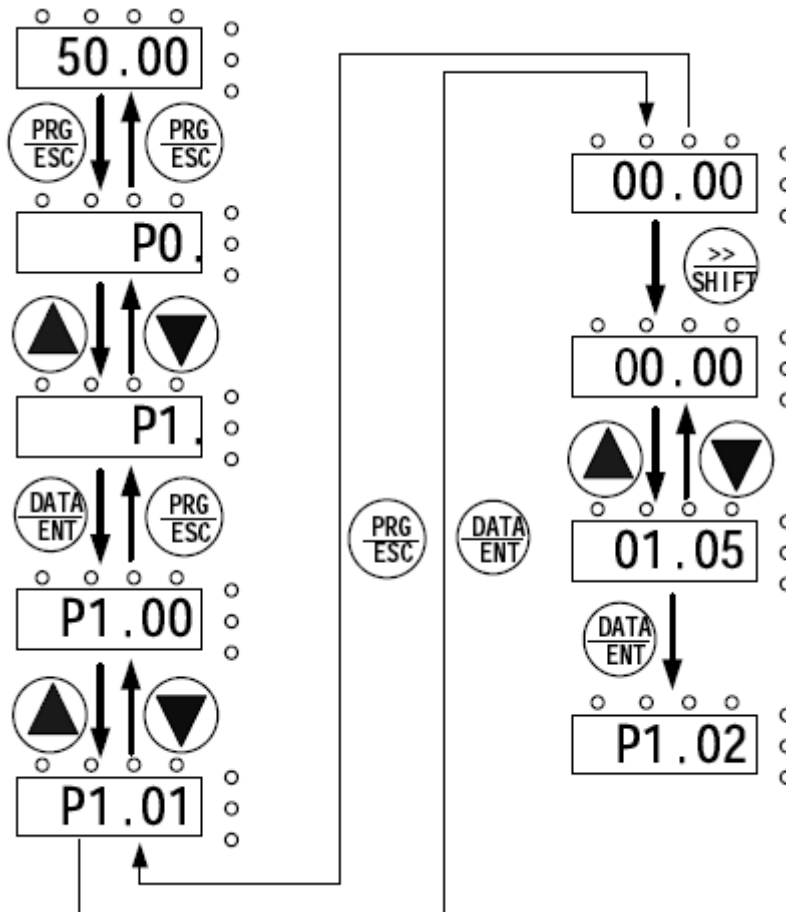

Figure 4.7.1 Level-3 Menu Operation Flow Diagram

In the level-3 menu, if no bit of parameters flickers, it indicates the functional code cannot be modified. The possible causes include:

- 1) The functional code cannot be modified, for example, actually measured parameters and operation record parameters.
- 2) The functional code cannot be modified in the operation state; you have to stop the equipment before modifying the functional code.

#### 4.7.2 Shortcut menu

Shortcut menu provides a quicker and more convenient means for viewing and modifying functional parameters. The user can add frequently used functional parameters to the shortcut menu. Parameter in the shortcut menu is displayed in the format of “hp0.11”, indicating that it is the functional parameter P0.11. Modifying a parameter in the shortcut menu has the same effect as modifying the parameter in the common programming state. A maximum of 16 functional parameters can be added to the shortcut menu. The user can

add or delete functional parameters to or from the shortcut menu when the functional code F7-03 is set to 0.

4.7.2-1 Adding shortcut parameter: To set the functional code P0.00 as a shortcut parameter, for example, operate as follows:

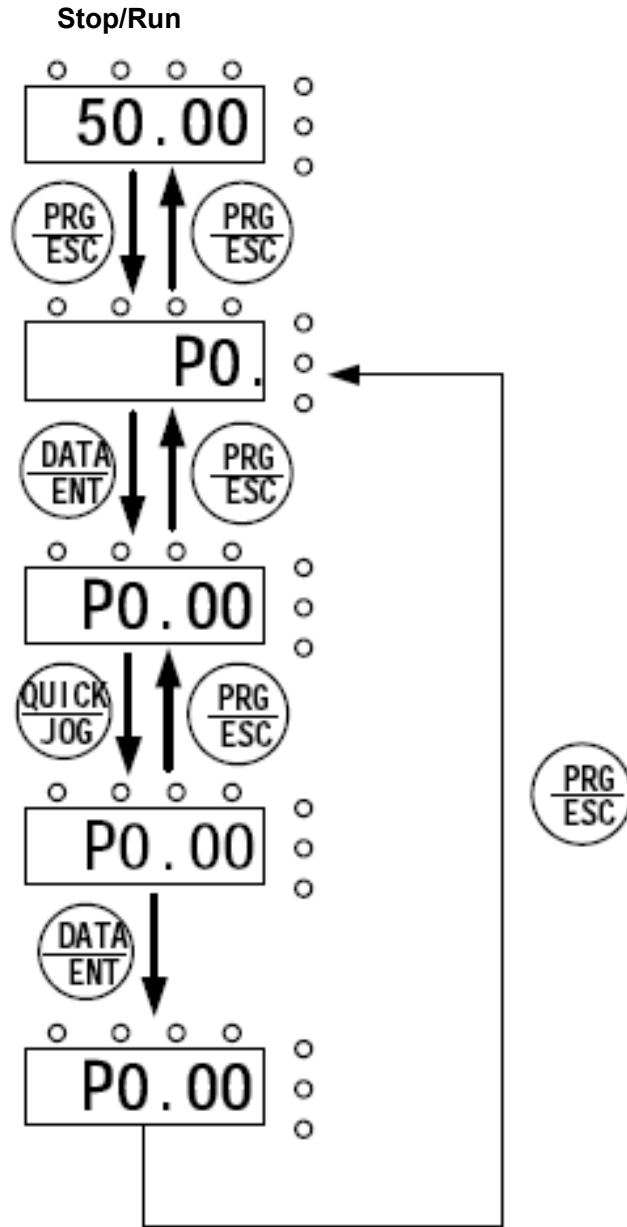

Figure 4.7.2-1 Example of Adding Shortcut Menu

Note: Press <QUICK/JOG> in the level-2 menu of the programming state, the displayed content flickers, prompting whether to save the parameter to the shortcut menu. To confirm the setting, press <DATA/ENT>. The displayed content stops flickering and the operation is completed. To cancel the setting, press <PRG/ESC>. The displayed content stops flickering and the operation is cancelled. If the system has already stored 16 parameters, it will give a prompt of “FULLP” if the user tries to store another parameter.

#### 4.7.2-2 Operation of shortcut parameters

The shortcut menu contains only two levels, corresponding to the level-2 and level-3 menus in the common programming state.

An operation example is as follows:

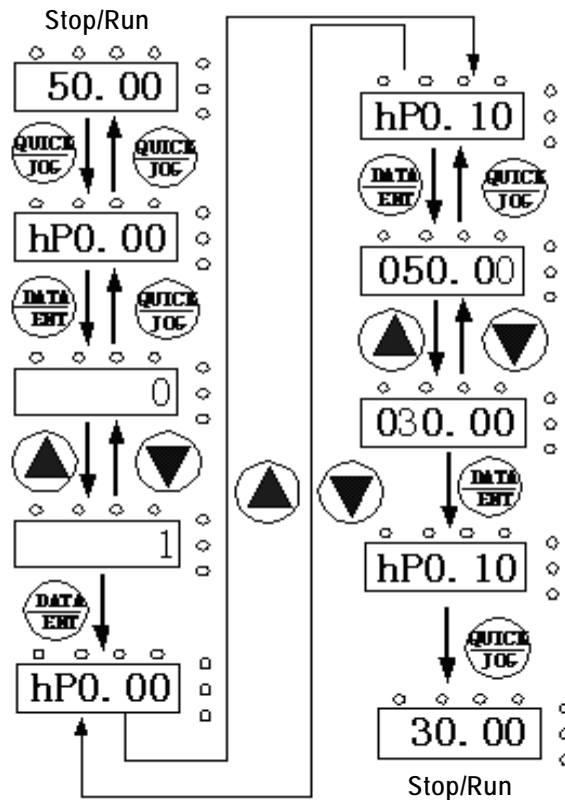

Figure 4.7.2-2 Example of Shortcut Menu Operation

Note: In the stop or operation display interface, press <QUICK/JOG> to enter the level-1 shortcut menu. Use the <^> and <v> keys to select different shortcut parameters, and then press <DATA/ENT> to enter the level-2 shortcut menu. Modification method of level-2 shortcut menu is the same as that for level-3 menu common parameters. To return to the previous menu, press <QUICK/JOG>.

If the “NULLP” appears when the user enters the level-1 shortcut menu, it indicates the shortcut menu is null.

#### 4.7.2-3 Deleting shortcut parameters

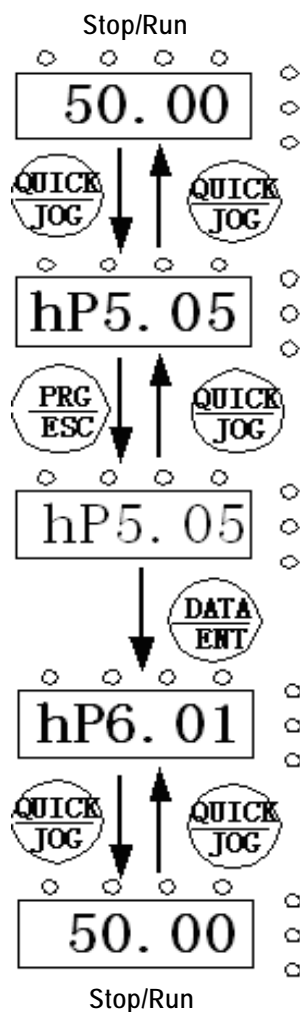

Figure 4.7.2-3 Example of Shortcut Menu Deletion Operation

Note: Press <PRG/ESC> in the level-1 shortcut menu, the display flickers, prompting whether to delete the parameter. To confirm the deletion, press <DATA/ENT>. The display stops flickering and shifts to the next shortcut parameter, and the deletion operation is completed. To cancel the deletion, press <QUICK/JOG>. The display stops flickering and the deletion operation is cancelled. If the shortcut parameter to be deleted is the last one, the “NULLP” appears after the deletion, indicating there are no shortcut parameters.

#### 4.7.3 Fault reset

If a fault occurs with the inverter, the inverter will give a prompt on fault information. The user can perform fault reset operation through the <STOP/RST> key on the keypad or the terminal function (P5 group). After fault reset, the inverter goes to the standby state. If the

user does not reset an inverter in the faulty state, the inverter will go to the operation protection state and stop operation.

#### 4.7.4 Parameter copying

For details, refer to the functional description of the external LCD keypad.

#### 4.7.5 Motor parameter self-learning

The user can select the operation mode with or without PG vector control. Enter the parameters on the name plate of a motor correctly before starting the inverter. For c series inverters, the user has to match the standard motor parameters according to the parameters on their name plates. Vector control mode depends largely on motor parameters. To ensure good control performance, it is required to obtain correct parameters of the controlled motor.

Operating procedures for motor parameter self-learning are as follows:

Firstly, select the operation command channel selection (P0.01) as the keypad command channel.

Then, enter the following parameters according to the name plate of the motor:

- P2.01: Rated frequency of the motor;
- P2.02: Rated rotation speed of the motor;
- P2.03: Rated voltage of the motor;
- P2.04: Rated current of the motor;
- P2.05: Rated power of the motor.

Set P0.17 to 1. For detailed description of motor parameter self-learning process, refer to the description of the functional code P0.17. Press <RUN> on the keypad and the inverter will automatically calculate the following parameters of the motor:

- P2.06: Resistance of the motor stator;
- P2.07: Resistance of the motor rotor;
- P2.08: Inductance of the motor stator and rotor;
- P2.09: Mutual inductance of the motor stator and rotor;
- P2.10: Motor no-load current; implementing motor parameter self-learning.

**Note: The motor must be separated from the load; otherwise, motor parameters**

## 4.8 Installation and Debugging Procedures

### 4.8.1 Connection of lines

4.8.1-1 The connection method of the power line is as follows: Correctly identify the main AC contactor for the startup of the motor, disconnect the 3-phase AC wires between the air switch of the injection molding machine and the main AC contactor (Note that if the main AC contactor has other power lines, re-connect them to the air switch), and then connect the <R, S, T> 3-phase power lines of the energy saver to the air switch, and the <U, V, W> 3-phase output lines to the main AC contactor.

4.8.1-2 The connection method of the signal line is as follows: Correctly identify proportional flow signal and proportional pressure signal. When the signal is the current signal, 1IA and 1IB on the signal acquisition card are input terminals for current signal channel 1, and the corresponding internal channel is AI3. The functional code is P0.03=2, and the corresponding parameters are set to P5.25-P5.29. Where the 1IA is the positive input terminal of differential current and the 1IB is the negative input terminal of differential current. 2IA and 2IB are input terminals for current signal channel 2, and the corresponding internal channel is AI4. The functional code is P0.04=1 and the corresponding parameters are set to P5.30-P5.34. Where the 2IA is the positive input terminal of differential current and the 2IB is the negative input terminal of differential current. Besides, the combination mode of these two signal channels is set by the parameter P0.06. Please pay attention to the flow direction of current on the signal line; the user can also make a judgment according to the on/off status of the indicator (the brightness of the indicator varies with the current signal). When the current signal is greater than 0.6A, all indicators become on, indicating the wiring is correct.

4.8.1-3 Upon completion of wiring, test the direction of mains supply mode and energy saving mode, make sure the phase sequence of corresponding motors of the injection molding machine is consistent, and measure signals on two channels with a multimeter to check whether the output is normal.

**4.8.2 Perform motor parameter self-learning. Self-learning steps are precautions are as follows:**

4.8.2-1 Enter correctly the parameters on the name plate of the motor. The corresponding functional codes are P2.01 to P2.05.

a) Enter rated power of the motor (very important)

P2.05 (Rated power of the motor)	On the name plate of the motor
----------------------------------	--------------------------------

b) Enter the following four parameters:

P2.01 (Rated frequency of the motor)	On the name plate of the motor
P2.02 (Rated rotation speed of the motor)	On the name plate of the motor
P2.03 (Rated voltage of the motor)	On the name plate of the motor
P2.04 (Rated current of the motor)	On the name plate of the motor

4.8.2-2 Change the following parameters

P0.01 (Keypad control)	0
P0.11 (Acceleration time)	20
P0.12 (Deceleration time)	20

4.8.2-3 Turn the energy saver to the energy saving state, and start the motor of the injection molding machine (ensure the connection between the inverter output and the motor). At this time, you cannot operate the injection molding machine (the motor has no load). Then, change the P0.17 to 1. At last, press the green <RUN> key, and the inverter starts self-learning. Upon completion of self-learning, the prompt of END appears.

4.8.2-4 After self-learning of motor parameters, check the parameter P2.10. The value shall be less than 60% of the rated current of the motor (P2.04); otherwise, it is abnormal, and it is necessary to confirm whether the motor is free of load when the parameter self-learning takes place.

4.8.2-5 After the self-learning, the user cannot change parameters in group P2 at will. If any parameter on the name plate of the motor (P2.01-P2.05) changes, it is necessary to conduct the motor parameter self-learning again.

4.8.2-6 If parameters on the name plate of the motor are unavailable, use default parameters. In this case, enters motor power (P2.05) only, and it is unnecessary to carry out parameter self-learning.

4.8.2-7 If the user wants to change the result just after the completion of self-learning, the user can change the rated power of the motor (P2.05) to a different value, and then change it to the current required value. A default value will be generated automatically.

**4.8.3 Before debugging, conduct commissioning with the keypad to observe whether the system runs normally and whether motor parameters are correct.**

4.8.3-1 Set P0.00=0 (Open loop vector control), P0.11=0.1s (acceleration time), P0.10 = 50.00 Hz. Conduct acceleration and deceleration for several times. If no OC fault occurs, the system is normal.

4.8.3-2 When the motor reaches its rated frequency (P2.01), view the output voltage with the <SHIFT> key on the keypad. If the output voltage is close to the rated voltage of the motor (P2.03), it indicates the system is normal and motor parameters are correct. If the output voltage is excessively high, appropriately reduce the no-load current of the motor (P2.10); if the output voltage is excessively low, appropriately increase the no-load current of the motor (P2.10).

4.8.3-3 When the motor reaches half of its rated frequency (P2.01), view the output voltage. If the output voltage is about half of the rated voltage, it indicates the system

is normal; otherwise, motor parameters are incorrect. If the output voltage is excessively high, appropriately reduce the no-load current of the motor (P2.10); if the output voltage is excessively low, appropriately increase the no-load current of the motor (P2.10).

#### 4.8.4 Debugging contents

Enter the corresponding functional code and set the parameters by referring to the following settings:

4.8.4-1 Modify the following basic parameters:

Functional Code	Reference Set Value	Functional Code	Reference Set Value	Functional Code	Reference Set Value
P0.00	0	P0.08		P7.04	0
P0.01	1	P0.09		P8.16	3
P0.02	2	P0.11	0.7	P8.18	1.0
P0.03	2	P0.12	1.5		
P0.04	1	P1.14	0		
P0.06	3	P4.12	1		

4.8.4-2 Parameters for adjusting signal amplification rate are as follows:

Functional Code	Function Description	Functional Code	Function Description
P5.25	Lower limit of channel 1	P5.30	Lower limit of channel 2
P5.26	Setting corresponding to the lower limit of channel 1	P5.31	Setting corresponding to the lower limit of channel 2
P5.27	Upper limit of channel 1	P5.32	Upper limit of channel 2
P5.28	Setting corresponding to the upper limit of channel 1	P5.33	Setting corresponding to the upper limit of channel 2

When the energy saver runs in the mains supply mode, flow and pressure parameters can be adjusted separately. Change P0.06 to 0, observe flow parameters of channel 1, and compare with the analog frequency of the energy saver. If it is inconsistent, adjust the parameters P5.25 to P5.28. After that, change P0.06 to 1, observe pressure parameters of channel 2, and compare with the analog frequency of the energy saver. If it is inconsistent, adjust the parameters P5.30 to P5.33. At last, change P0.06 to 3, which is the standard

comparative input for two channels.

4.8.4-3 During the use of the energy saver, if protection function is incorrectly enabled, motor parameters may be incorrect. Change P0.00 to 2 (V/F control) and try to identify the cause.

4.8.4-4 Make sure the motor is in the stop state during the switchover between the mains supply mode and energy saving mode; otherwise, the inverter will generate an OC fault.

**4.8.5 If multi-step speed is required for the commissioning of some injection molding machines, try the following methods:**

4.8.5-1 Set the following parameters through the JOG terminal (S2):

Functional Code	Function Description
P5.03 (S2 terminal function selection)	4 (FWD JOG); 5 (REV JOG)
P8.06 (JOG run frequency)	Set according to actual situations (less than the maximum frequency)
P8.07 (JOG acceleration time)	0.7
P8.08 (JOG deceleration time)	2.0

4.8.5-2 Set the following parameters through the multi-step speed terminal (S4):

Functional Code	Function Description
P5.05 (S4 terminal function selection)	16 (Multi-step speed terminal 1)
PA.04 (Multi-step speed 1)	

### 5.1 Switchover between Mains Supply Mode and Energy Saving Mode

#### 5.1.1 Energy saving to mains supply operation

- The energy saver operates in the energy saving state and the energy saving operation indicator is on.
- Shut down the main oil pump motor and make sure the motor stops.
- Turn the changeover switch and the mains supply operation indicator becomes on. The energy saver operates in the mains supply state.
- Turn on the main motor of the injection molding machine and perform normal operations.

#### 5.1.2. Mains supply to energy saving operation

- The energy saver operates in the mains supply state and the mains supply operation indicator is on.
- Shut down the main oil pump motor and make sure the motor stops.
- Turn the changeover switch and the energy saving operation indicator becomes on. The energy saver operates in the energy saving state.
- Turn on the main motor of the injection molding machine and perform normal operations.

**★ Key Point ★**

**Make sure to shut down the motor of the injection molding machine before carrying out the switchover between mains supply operation mode and energy saving operation mode.**

### 5.2 Test Stage

With the same mold and materials, the quantity of electricity consumed by an injection molding machine in the energy saving operation state and in the mains supply operation state can be measured respectively by the switchover between these two modes. Therefore, the energy saving ratio can be calculated. During the switchover, production

technicians must be on the site to inspect product quality.

In the energy saving operation state, some injection molding machines may have different technological process flow rate (speed) parameters and pressure parameters from those in the mains supply operation state. Parameters of the injection molding machines in energy saving operation mode are set to values comparatively greater than those set in mains supply operation mode. For these injection molding machines, parameters have to be adjusted when performing the switchover between mains supply mode and energy saving mode to turn out qualified products.

### **5.3 Normal Operation Stage of Energy Saver**

After the energy saver is installed and debugged, always turn it to the energy saving operation mode unless it is required to have a test. It is not necessary for a user to adjust the parameters of the energy saver when a different type of mold is used. No matter what kind of product is produced, it is only required to set the flow (speed) and pressure parameters of the injection molding machine at different stages such as mold clamping, injection, melting, mold opening, and ejector pin, until the qualified products are turned out.

**Note:**

- 1) Never turn the changeover switch when the equipment is running; otherwise, the energy saver may fail.
- 2) Do not perform the mains supply/energy saving mode switchover frequently; otherwise, it may lead to protection action of the energy saver.

**★Warning!★**

→ Do not connect the AC power with output terminals (U, V, W); otherwise, it may cause personal injury or accident.

→ Do not carry out insulation test between cables of the energy saver.

### 6.1 Fault Diagnosis and Corrective Action

If a fault occurs during the operation of the inverter, the LED display automatically shows the fault. At this time, energy saver has implemented effective protection against the fault.

The output terminal stops output and the fault indicator flickers. The fault information is indicated by a code consisting of 2 to 4-digit letters and digits.

Fault information and removal

Fault Code	Fault Type	Possible Cause	Solution
OUT1	Inverter unit phase U failure	1. Acceleration is too quick; 2. Internal damage to the IGBT of the phase; 3. Misoperation caused by interference; 4. Whether the grounding is sound.	1. Increase acceleration time;  2. Seek for support;  3. Check whether there is strong interference source among peripherals.  4. Check the grounding method and state of the grounding cable.
OUT2	Inverter unit phase V failure		
OUT3	Inverter unit phase W failure		
OC1	Acceleration operation over-current	1. Acceleration is too quick; 2. Power grid voltage is too low; 3. The power of the inverter is too low.	1. Increase acceleration time;  2. Check power supply;  3. Select an inverter with a larger scale of power.
OC2	Deceleration operation over-current	1. Deceleration is too quick; 2. Load inertial torque is large; 3. The power of the inverter is too low.	1. Increase deceleration time;  2. Add appropriate energy consumption braking unit;  3. Select an inverter with a larger scale of power.
OC3	Constant-speed operation over-current	1. Sudden change or exception happens to load; 2. Power grid voltage is too low; 3. The power of the inverter is too low. 4. During closed-loop vector high-speed operation, code	1. Check the load or reduce the sudden change to the load;  2. Check power supply;  3. Select an inverter with a larger scale of power;  4. Check code wheel and wires.

		wheel wires break or fail suddenly.	
OV1	Acceleration operation over-voltage	<ol style="list-style-type: none"> <li>1. Abnormal input voltage;</li> <li>2. Restart a rotating motor after transient power failure;</li> </ol>	<ol style="list-style-type: none"> <li>1. Check power supply;</li> <li>2. Avoid restarting after stopping.</li> </ol>
OV2	Deceleration operation over-voltage	<ol style="list-style-type: none"> <li>1. Deceleration is too quick;</li> <li>2. Load inertia is large;</li> <li>3. Abnormal input voltage.</li> </ol>	<ol style="list-style-type: none"> <li>1. Decrease deceleration time;</li> <li>2. Increase energy consumption braking units;</li> <li>3. Check power supply;</li> </ol>
OV3	Constant-speed operation over-voltage	<ol style="list-style-type: none"> <li>1. Abnormal change to input voltage;</li> <li>2. Load inertia is large</li> </ol>	<ol style="list-style-type: none"> <li>1. Install input reactor;</li> <li>2. Add appropriate energy consumption braking unit;</li> </ol>
UV	Bus under-voltage	<ol style="list-style-type: none"> <li>1. Power grid voltage is too low</li> </ol>	<ol style="list-style-type: none"> <li>1. Check power supply of the power grid;</li> </ol>
OL1	Motor overload	<ol style="list-style-type: none"> <li>1. Power grid voltage is too low;</li> <li>2. Rated current of the motor is incorrectly set;</li> <li>3. Rotation of motor blocked or excessive sudden change;</li> <li>4. Close-loop vector control, code wheel in reverse direction, long-term low-speed operation;</li> <li>5. The load is too light.</li> </ol>	<ol style="list-style-type: none"> <li>1. Check the voltage of the power grid;</li> <li>2. Set rated current of the motor again;</li> <li>3. Check the load and adjust torque raise;</li> <li>4. Adjust code wheel signal direction;</li> <li>5. Select an appropriate motor.</li> </ol>
OL2	Inverter overload	<ol style="list-style-type: none"> <li>1. Acceleration is too quick;</li> <li>2. Restart a rotating motor;</li> <li>3. Power grid voltage is too low;</li> <li>4. Overload;</li> <li>5. Close-loop vector control; code wheel in reverse direction; long-term low-speed</li> </ol>	<ol style="list-style-type: none"> <li>1. Decrease the acceleration;</li> <li>2. Avoid restarting after stopping.</li> <li>3. Check the voltage of the power grid;</li> <li>4. Select an inverter with larger power;</li> <li>5. Adjust code wheel signal direction;</li> </ol>

		operation;	
SPI	Phase loss on the input side	Phase loss at input terminals R, S, T	<ol style="list-style-type: none"> <li>1. Check power supply;</li> <li>2. Check installation and wiring.</li> </ol>
SPO	Phase loss on the output side	<ol style="list-style-type: none"> <li>1. U, V, W phase-loss output (or grave imbalance of three phases of load)</li> <li>2. Pre-excitation cannot stop during the pre-excitation period if it is not connected with the motor.</li> </ol>	<ol style="list-style-type: none"> <li>1. Check output wires;</li> <li>2. Check motor and cables.</li> </ol>
OH1	Rectifier module overheat	<ol style="list-style-type: none"> <li>1. Transient over-current of inverter;</li> <li>2. Alternated three output phases or ground connection short-circuited</li> </ol>	<ol style="list-style-type: none"> <li>1. Refer to solution to over-current;</li> <li>2. Redistribute cables;</li> <li>3. Clean air duct or replace the fan;</li> </ol>
OH2	Inverter module overheat	<ol style="list-style-type: none"> <li>3. Air duct is blocked or fan is damaged;</li> <li>4. Ambient temperature is too high;</li> <li>5. Wires or connectors of the control board become loose;</li> <li>6. Auxiliary power supply is damaged, under-voltage with drive voltage;</li> <li>7. Straight through of power module bridge leg;</li> <li>8. Control board fails.</li> </ol>	<ol style="list-style-type: none"> <li>4. Decrease ambient temperature;</li> <li>5. Check and connect again;</li> <li>6. Seek for service;</li> <li>7. Seek for service;</li> <li>8. Seek for service.</li> </ol>
EF	External fault	1. SI external fault input terminal action	1. Check the input of external equipment
CE	Communication fault	<ol style="list-style-type: none"> <li>1. Incorrect baud rate setting;</li> <li>2. Error with serial communication;</li> <li>3. Long-time communication</li> </ol>	<ol style="list-style-type: none"> <li>1. Set appropriate baud rate;</li> <li>2. Press &lt;STOP/RST&gt; to reset and seek for service;</li> <li>3. Check the wires of the communication interface.</li> </ol>

		interruption	
ITE	Current detection circuit fault	<ol style="list-style-type: none"> <li>1. Poor contact of connectors of the control board;</li> <li>2. Damage to auxiliary power supply;</li> <li>3. Hall element damaged;</li> <li>4. Amplification circuit failure</li> </ol>	<ol style="list-style-type: none"> <li>1. Check connectors and reconnect the wires;</li> <li>2. Seek for service;</li> <li>3. Seek for service;</li> <li>4. Seek for service.</li> </ol>
TE	Motor self-learning fault	<ol style="list-style-type: none"> <li>1. Motor capacity does not match inverter capacity;</li> <li>2. Incorrect settings for rated parameters of the motor;</li> <li>3. Large deviation between self-learned parameters and standard parameters;</li> <li>4. Self-learning timeout</li> </ol>	<ol style="list-style-type: none"> <li>1. Replace inverter model;</li> <li>2. Set rated parameters according to those on the name plate of the motor;</li> <li>3. Recognize the parameters again when the motor is free of load;</li> <li>4. Check motor wires and parameter settings.</li> </ol>
PCE	Coder wire broken fault	<ol style="list-style-type: none"> <li>1. With PG vector control, coder signal line broken;</li> <li>2. Coder damage</li> </ol>	<ol style="list-style-type: none"> <li>1. Check coder wires and reconnect the line;</li> <li>2. Check whether the coder has output.</li> </ol>
PCDE	Coder reverse fault	<ol style="list-style-type: none"> <li>1. With PG vector control, coder signal line is reversely connected.</li> </ol>	<ol style="list-style-type: none"> <li>1. Check coder wires and adjust the connection.</li> </ol>
OPSE	System fault	<ol style="list-style-type: none"> <li>1. Severe interference prevents main control board from working normally;</li> <li>2. Environment noise prevents main control board from working normally.</li> </ol>	<ol style="list-style-type: none"> <li>1. Press &lt;STOP/RST&gt; to reset or add power filter on the power input side;</li> <li>2. Press &lt;STOP/RST&gt; to reset and seek for service.</li> </ol>
EEP	EEPROM read and write fault	<ol style="list-style-type: none"> <li>1. Control parameter reading or writing error;</li> <li>2. Damage to EEPROM</li> </ol>	<ol style="list-style-type: none"> <li>1. Press &lt;STOP/RST&gt; to reset and seek for service;</li> <li>2. Seek for service.</li> </ol>
PIDE	PID feedback wire broken fault	<ol style="list-style-type: none"> <li>1. PID feedback line broken;</li> <li>2. PID feedback</li> </ol>	<ol style="list-style-type: none"> <li>1. Check PID feedback signal line;</li> <li>2. Check PID feedback</li> </ol>

		source disappeared	source.
BCE	Braking unit fault	1. Braking line failed or braking pipe damaged; 2. External braking resistor is low	1. Check braking unit or replace braking pipe; 2. Increase braking resistors.
	Reserved by the factory		

## 6.2 Handling of Common Faults

### 6.2.1 Normal protection of energy saver

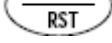
If the energy saver is in the normal protection state, press  on the keypad to conduct fault reset, and then restart the oil pump motor.

After reset, stop the energy saver and then turn it to the energy saving state, and start the motor.

Shut down the main power supply of the energy saver and power on it again after all LEDs on the keypad are off, and then start the oil pump motor.

### 6.2.2 No display when energy saver powered on

Check whether the power supply of the energy saver is consistent with the rated voltage.

If there is a fault with the power supply, check and remove the fault.

Check whether the 3-phase rectifier bridge is in good condition. If it is broken, seek for external service.

Check whether the CHARGE indicator is on. If it is off, the fault usually lies on the rectifier bridge or buffer resistor; if it is on, the fault may lie on the switching power supply. In this case, seek for external service.

### 6.2.3 Power supply air switch tripped when energy saver powered on

Check whether power supplies are grounded securely or short-circuited; remove the fault if any.

Check whether the rectifier bridge is broken down. If it is broken down, seek for service.

### 6.2.4 Motor does not rotate after the energy saver runs

Check whether U, V, W terminals have balanced 3-phase output. If yes, the motor lines or the motor itself may be damaged, or the motor is blocked due to mechanical reasons. Please remove the fault.

It may have output but three phases are unbalanced. It may be a fault with the drive board or output module of the energy saver. Please seek for service.

If there is no output voltage, it may be a fault with the drive board or the output module. Please seek for service.

### **6.2.5 The display is normal when the energy saver is powered on, but power supply air switch is tripped when energy saver is running:**

Check whether there is short circuit between output modules. If yes, seek for external service.

Check whether leads of motor are short-circuited or grounded. Remove the fault if any.

If the tripping occurs occasionally and the distance between the motor and the energy saver is far, an output AC reactor may be added.

#### **★Note★**

**In general, it is unnecessary for the user to adjust parameters of the energy saver. If it is required so, please make adjustment under the direction of our technicians. Improper adjustment may result in injection molding machine fault or product defect.**

### **6.3 Adjustment of Common Product Defects**

<b>Product Defect</b>	<b>Cause</b>	<b>Adjustment</b>
Product inadequacy	Defect with material, material temperature , or mold	Adjust parameters of the injection molding machine.
	Injection pressure is too low.	Increase the value of injection pressure parameters.
	Injection time is too short.	Increase the value of injection time parameters.
	Injection speed is too slow.	Increase the value of injection speed parameters.
Product flash	Defect with mold, temperature, or material	Adjust parameters of the injection molding machine.
	Injection pressure is too high	Decrease the value of injection pressure parameters.

Product blistering	Defect with material or mold temperature	Adjust parameters of the injection molding machine.
	Injection pressure is too low.	Increase the value of injection pressure parameters.
	Injection speed is too high.	Decrease the value of injection speed parameters.
Product sinking	Defect with material temperature or material	Adjust parameters of the injection molding machine.
	Injection pressure is inadequate.	Increase the value of injection pressure parameters.
	Injection speed is too high.	Decrease the value of injection speed parameters.
	Holding time is too short.	Increase the value of injection time parameters.
Welding mark	Defect with material temperature or material	Adjust parameters of the injection molding machine.
	Injection speed is too low.	Increase the value of injection speed parameters.
	Injection pressure is too low.	Increase the value of injection pressure parameters.
Wires and ripple on the product surface	Defect with material, material temperature , or mold	Adjust parameters of the injection molding machine.
	Injection pressure is too low.	Increase the value of injection pressure parameters.
Warpage	Mold or mold temperature	Improve mold and adjust parameters of the injection molding machine.
	Cooling time is not long enough.	Increase the value of corresponding time parameters.
Instable dimension	Defect with material, temperature , or mold	Adjust parameters of the injection molding machine.
	Injection pressure is too low.	Increase the value of injection pressure parameters.
	Mold filling time is not long enough.	Increase the value of corresponding time parameters.
Product adhesion to mold	Defect with mold temperature or mold	Adjust parameters of the injection molding machine.
	Injection pressure is too high.	Decrease the value of injection pressure parameters.
	Injection time is too short.	Increase the value of corresponding time parameters.
Feed opening adhesion to mold	Material temperature is too high.	Adjust related temperature parameters.
	Cooling time is too short.	Increase the value of corresponding time parameters.

Cold slug or rigidity of product	Defect with material or mold temperature	Adjust parameters of the injection molding machine.
	Molding time is too short.	Increase the value of corresponding time parameters.
Color fading	Material temperature is too high.	Adjust related temperature parameters.
	Injection pressure is too high.	Decrease the value of injection pressure parameters.
	Injection time is too short.	Increase the value of corresponding time parameters.
	Injection pressure holding time is too long.	Decrease the value of corresponding time parameters.
Product strength deterioration	Defect with material, temperature, or mold	Adjust parameters of the injection molding machine.
	Molding temperature is too low.	Adjust related temperature parameters.



### WARNING

- Maintenance personnel must follow the stipulated repair and maintenance methods in their work.
- Only qualified and service-trained personnel can conduct maintenance operation.
- Before carrying out maintenance operation, shut down the power of the inverter first and wait at least 10 minutes.
- Do not directly touch components on the PCB; otherwise, the inverter may be damaged by static electricity.
- Upon completion of maintenance, make sure to tighten all screws.

### 7.1 Daily Maintenance

To prevent energy saver failure, ensure normal operation of the equipment, and prolong the service life of the energy saver, it is necessary to carry out daily maintenance for the energy saver. Daily maintenance covers:

Check Item	Content
Temperature/humidity	Make sure the ambient temperature is about 0°C to 50°C, and the related humidity is about 20% to 90%.
Oil mist and dust	Make sure there are no oil mist, dust, or condensed water,
Inverter	Check whether the inverter has abnormal overheat or vibration.
Fan	Make sure the fan works normally and is not blocked.
Power supply	Make sure the voltage and frequency of power supply are within permissible scope.
Motor	Check whether the motor has abnormal vibration, overheat, noise, or phase loss.

### 7.2 Periodic Maintenance

To prevent energy saver failure and ensure its long-term, high-performance and stable operation, users must carry out a periodic check (within six months) for the energy saver.

The check covers:

Check Item	Check Content	Solution
Screws of external cabinet	Whether screws become loose	Tighten them

PCB board	Dust and dirt	Clean dirt or dust with dry compressed air
Fan	Abnormal noise or vibration, or accumulated operation time exceeding 20,000 hours	<ol style="list-style-type: none"> <li>1. Clean irrelevant objects</li> <li>2. Replace the fan</li> </ol>
Electrolytic capacitor	Whether the color changes or with foreign smell	Replace the electrolytic capacitor
Heat sink	Dust and dirt	Clean dirt or dust with dry compressed air
Power components	Dust and dirt	Clean dirt or dust with dry compressed air

The product warranty is subject to the following provisions:

### **8.1 In case of quality defects, the warranty covers:**

#### **8.1-1 For domestic use**

- A warranty of repair, replacement, or return in one month from the date of shipment;
- Repair or replacement in three months from the date of shipment;
- Repair in 18 months from the date of shipment.

#### **8.1-2 For overseas use**

- For overseas use (excluding domestic use), the warranty covers repair in the place of purchasing in 12 months from the date of shipment.

### **8.2 Even within the warranty period, this warranty does not apply to (but paid maintenance service is available for):**

- Fault or damage caused by inappropriate operation or unauthorized repair or modification;
- Fault or damage caused by use against the requirements specified in standards and specifications;
- Component aging or fault caused by the use in an environment incompliant with the environment requirements provided in this manual;
- Damage arising from natural disasters such as earthquake, fire, wind storm, flood, lightning strike, abnormal voltage or other consequential damage;
- Equipment fault or damage when the purchaser fails to pay up the payment for the equipment as agreed.

### **8.3 Life-long paid maintenance service is provided for our products no matter when and where you buy it.**



Based on frequency conversion and speed adjusting principles, the following difference may occur when the injection molding machine operates in the energy saving mode in comparison with operating with mains supply. It is normal if such difference is kept under certain limit.

- Sharper Noise

The energy saver adopts frequency conversion technology to drive the oil-pump motor of the injection molding machine. According to characteristics of CHV110 series of energy savers, energy savers are driven by multiple pulses. Therefore, the motor gives out sharp noise of different loudness when it is running at different speeds.

- Higher Temperature (about 5°C)

The energy saver is driven by multiple pulses. Therefore, the temperature of the motor operating in the energy saving mode is slightly higher than that of the motor operating in the mains supply mode. At the low-speed operation stage, the temperature may increase by 5 to 8°C. Since the oil-pump motor of an injection molding machine usually runs at a medium or low speed in the energy saving mode, the temperature is about 5°C higher than that in the mains supply mode. The temperature-resistant grade of all materials used for the oil-pump motor is at grade F (resistant to a temperature up to 135°C) or above. Therefore, the temperature raise of the motor is within the permitted scope and will not have any impact on the use and service life of the motor.

## Attachment 1: List of Functional Parameters

Functional parameters of the CHV110 energy saver can be functionally divided into sixteen groups (P0 through PF). Where, PF refers to extended functional parameters. After the corresponding extension card is installed on the energy saver, the user can access to the group of parameters. Each functional group contains certain functional codes. Three levels of menus are used for the functional codes. For example, “P8.08” indicates the eighth functional code of the P8 functional group.

For the convenience of functional code setting, upon operation through the operation panel, the functional group numbers correspond to the level-one menu, the functional code numbers to the level-two menu, and functional code parameters to level-three menu.

1. The contents of the functional list are described as follows:

“Functional Code” in the first column: number of the functional parameter group and parameter;

“Name” in the second column: complete name of the functional parameter;

“Detailed Parameter Description” in the third column: detailed description of the functional parameter;

“Setting Range” in the fourth column: valid setting range of the functional parameter;

“Default Value” in the fifth row: original default setting of the functional parameter;

“Change” in the sixth row: change property of the functional parameter (that is, whether to allow change and the change conditions);

The description is as follows:

“O”: indicates that the setting value of the parameter can be changed upon stop and running of the energy saver;

“⊙”: indicates that the setting value of the parameter cannot be changed during running of the energy saver;

“●”: indicates that the parameter value is the actually detected and recorded value and cannot be changed.

(The energy saver has conducted automatic detection restriction upon the modification

properties of the parameters, so that the user can avoid modifications by mistake). )

“LCD Display” in the seventh column: brief description of the functional parameter name on the LCD display in the operation panel.

“Serial No.” in the eighth column: sequence number of the functional code among all the functional codes, and likewise, it also indicates the register address in communications.

2. “Parameter Notation” is decimal (DEC) notation. If hexadecimal notation is used for parameters, the data of each bit is mutually independent upon parameter editing. The range value of some bits can be in hexadecimal notation (0~F).

3. “LCD Display Description” in the table is only valid when an external LCD operation panel is used.

4. “Default Value”: indicates the value after the refreshing of the functional code parameter upon default parameter operation recovery operation. However, the actually detected parameter values or recorded values will not be refreshed.

5. To protect parameters more efficiently, the energy saver provides password protection for the functional codes. After a user password (that is, the parameter if user password P7.00 is not zero) is set, when the user press <PRG/ESC> to enter functional code edit status, the system will first enter user password verification state, displaying “----“. The operator has to enter the correct user password; otherwise the operator cannot enter the edit state. For factory setting parameter area, it is necessary to enter the correct factory password before entry. (Attention: Do not try to modify the default settings. Improper parameter settings may easily cause abnormal operation of the energy saver or even damage to the energy saver.) If password protection is not in locked state, the user password can be modified anytime. The last entered user password shall prevail. If P7.00 is set to 0, the user password can be cancelled. Upon power-up, if P7.00 is not set to 0, the parameters will be protected by the user password. When serial communications is used to modify functional code parameters, the above rules should also be followed as for user password function.

Functional Code	Name	Detailed Parameter Description	Setting Range	Default Value	Change	LCD Display	Serial No.
P0.00	Speed control mode	0: Vector control without PG 1: Vector control with PG 2: V/F control	0~2	0	⊙	Speed control mode	0.
P0.01	Run command channel	0: Keypad command channel (LED goes off) 1: Terminal command channel (LED flashes) 2: Communication command channel (LED lights up)	0~2	0	⊙	Command selection	1.
P0.02	Keypad and terminal UP/DOWN setting	0: Enabled, and stored upon inverter power-off 1: Enabled, and not stored upon inverter power-off 2: Invalid	0~2	0	⊙	UP/DOWN setting	2.
P0.03	Frequency command selection A	0: Keypad setting 1: Analog AI1 setting 2: Analog AI3 setting 3: High-speed pulse setting (HDI1) 4: Simple PLC program setting 5: Multi-step running setting 6: PID control setting 7: Remote communication setting	0~7	0	⊙	Frequency A command selection	3.
P0.04	Frequency command selection B	0: Analog AI2 setting 1: Analog AI4 setting 2: High-speed pulse setting (HDI2)	0~2	0	⊙	Frequency B command selection	4.
P0.05	Frequency command reference object selection B	0: Maximum output frequency 1: Frequency A command	0~1	0	○	Reference job	5.
P0.06	Setting source combination mode	0: A 1: B 2: A+B 3: Max(A, B (	0~3	0	○	Setting source combination	6.
P0.07	Maximum output frequency	600.00~10.00 Hz	10.00~600.00	50.00 Hz	⊙	Max. frequency	7.
P0.08	Upper operating frequency limit	P0.09~ P0.07 (maximum frequency)	P0.09~P0.07	50.00 Hz	○	Upper frequency limit	8.
P0.09	Lower operating frequency limit	0.00 Hz ~ P0.08 (upper operating frequency limit)	~0.00 P0.08	0.00 Hz	○	Lower frequency limit	9.
P0.10	Keypad setting frequency	0.00 Hz ~ P0.08 (upper operating frequency limit)	~0.00 P0.08	50.00 Hz	○	Keypad setting frequency	10.
P0.11	Acceleration time 0	3600.0~0.0 s	0.0~3600.0	20.0 s	○	Acceleration time 0	11.

Functional Code	Name	Detailed Parameter Description	Setting Range	Default Value	Change	LCD Display	Serial No.
P0.12	Deceleration time 0	3600.0~0.0 s	0.0~3600.0	20.0 s	○	Deceleration time 0	12.
P0.13	Running direction selection	0: Running in default direction 1: Running in opposite direction 2: Reverse running prohibited	0~2	0	⊙	Running direction	13.
P0.14	Carrier frequency setting	16.0~1.0 kHz	1.0~16.0	Set by model	○	Carrier frequency	14.
P0.17	Motor parameter self-learning	0: No operation 1: Parameter self-learning	0~1	0	⊙	Parameter self-learning	15.
P0.18	Functional parameter recovery	0: No operation 1: Recover default value 2: Clear fault files	0~2	0	⊙	Parameter recovery	16.

P1.14	Action when operating frequency is less than the lower frequency limit (the lower frequency limit is valid if it is greater than zero)	0: Run at lower frequency limit 1: Stop 2: Dormant and standby	0~2	0	⊙	Action at lower frequency limit	17.
P2.01	Rated frequency of motor	0.01Hz~P0.07 (maximum frequency)	~0.01 P0.07	50.00 Hz	⊙	Rated frequency of motor	18.
P2.02	Rated rotation speed of motor	36000~0 rpm	0~36000	1460 rpm	⊙	Rated rotation speed of motor	19.
P2.03	Rated voltage of motor	460~0 V	0~460	380 V	⊙	Rated voltage of motor	20.
P2.04	Rated current of motor	1000.0~0.1 A	0.1~1000.0	Set by model	⊙	Rated current of motor	21.
P2.05	Rated power of motor	900.0~0.4 kW	0.4~900.0	Set by model	⊙	Rated power of motor	22.
P2.10	Idle current of motor	655.35~0.01 A	0.01~655.35	Set by model	○	Idle current	23.
P4.01	Torque boost	0.0%: (automatic) 0.1% ~ 30.0%	0.0~30.0	1.0%	○	Torque boost	24.
P4.02	torque boost cutoff	0.0% ~ 50.0% (corresponding to rated frequency of the motor)	0.0~50.0	20.0%	⊙	torque boost cutoff	25.

Functional Code	Name	Detailed Parameter Description	Setting Range	Default Value	Change	LCD Display	Serial No.
P4.10	AVR function selection	0: Invalid 1: Full-range enabled 2: Disabled upon deceleration	0~2	1	○	AVR selection	26.
P4.11	Energy-saving running selection	0: No action 1: Automatic energy-saving running	0~1	0	○	Energy saving running	27.
P5.00	HDI input type selection	0: HDI1 and HDI2 are high-speed pulse inputs 1: HDI1 is digital input, HDI2 is high-speed pulse input 2: HDI2 is digital input, HDI1 is high-speed pulse input 3: HDI1 and HDI2 are digital inputs	0~3	0	⊙	Input type selection	28.
P5.01	Terminal function input selection	0: Physical digital input 1: Communication virtual terminal input	0~1	0	⊙	Terminal input selection	29.
P5.02	S1 terminal function selection	0: No function 1: Forward running 2: Reverse running 3: 3-wire run control	0~47	1	⊙	S1 function selection	30.
P5.03	S2 terminal function selection	4: Forward jogging 5: Reverse jogging 6: Free stop	0~47	4	⊙	S2 function selection	31.
P5.04	S3 terminal function selection	7: Fault reset 8: Run pause 9: External fault input	0~47	7	⊙	S3 function selection	32.
P5.05	S4 terminal function selection	10: Frequency setting increment (UP) 11: Frequency setting decrement (DOWN)	0~47	0	⊙	S4 function selection	33.
P5.06	S5 terminal function selection	12: Frequency increase/decrease setting clear 13: Switching between A setting and B setting	0~47	0	⊙	S5 function selection	34.
P5.07	HDI 1 terminal digital input function selection	14: Switching between (A+B) setting and A setting	0~47	0	⊙	HDI1 function selection	35.
P5.08	HDI 2 terminal digital input function selection	15: Switching between (A+B) setting and B setting 16: Multi-step speed terminal 1	0~47	0	⊙	HDI2 function selection	36.
P5.09	S6 terminal function selection	17: Multi-step speed terminal 2 18: Multi-step speed terminal 3	0~47	0	⊙	S6 function selection	37.
P5.10	S7 terminal function selection	19: Multi-step speed terminal 4	0~47	0	⊙	S7 function selection	38.

Functional Code	Name	Detailed Parameter Description	Setting Range	Default Value	Change	LCD Display	Serial No.
P5.11	S8 terminal function selection	20: Multi-step pause 21: Acceleration/deceleration time selection 1 22: Acceleration/deceleration time selection 2 23: Simple PLC reset 24: Simple PLC pause 25: PID control pause 26: Wobble frequency pause (stop at the current frequency) 27: Wobble frequency reset (return to center frequency) 28: Counter reset 29: Length reset 30: Acceleration/deceleration disabled 31: Torque control disabled 32~47: Reserved	0~47	0	⊙	S8 function selection	39.
P5.12	Count of digital input filter	1~10	1~10	5	○	Count of digital input filter	40.
P5.13	Terminal control run mode	0: Two-wire control, with integrated enable and direction 1: Two-wire control, with separated enable and direction 2: Three-wire control 1 3: Three-wire control 2	0~3	0	⊙	Terminal run mode	41.
P5.14	Terminal UP/DOWN Frequency increment change rate	50.00~0.01 Hz/s	0.01~50.00	0.50 Hz/s	○	Frequency increment change rate	42.
P5.15	Lower AI1 limit	0.00 V 10.00~V	0.00~10.00	0.00 V	○	Lower AI1 limit	43.
P5.16	Corresponding setting of lower AI1 limit	-100.0%~100.0%	-100.0~100.0	0.0%	○	Lower AI1 limit setting	44.
P5.17	Upper AI1 limit	0.00 V 10.00~V	0.00~10.00	10.00 V	○	Upper AI1 limit	45.
P5.18	Corresponding setting of upper AI1 limit	-100.0%~100.0%	-100.0~100.0	100.0%	○	Upper AI1 limit setting	46.
P5.19	AI1 input filter time	0.00 s 10.00~s	0.00~10.00	0.10 s	○	AI1 filter time	47.
P5.20	Lower AI2 limit	0.00 V 10.00~V	0.00~10.00	0.00 V	○	Lower AI2 limit	48.
P5.21	Corresponding setting of lower AI2 limit	-100.0%~100.0%	-100.0~100.0	0.0%	○	Lower AI2 limit setting	49.

Functional Code	Name	Detailed Parameter Description	Setting Range	Default Value	Change	LCD Display	Serial No.
P5.22	Upper AI2 limit	0.00 V 10.00~V	0.00~10.00	10.00 V	O	Upper AI2 limit	50.
P5.23	Corresponding setting of upper AI2 limit	-100.0%~100.0%	-100.0~100.0	100.0%	O	Upper AI2 limit setting	51.
P5.24	AI2 input filter time	0.00 s 10.00~s	0.00~10.00	0.10 s	O	AI2 filter time	52.
P5.25	Lower AI3 limit	10.00- V ~10.00V	-10.00~10.00	0.00 V	O	Lower AI3 limit	53.
P5.26	Corresponding setting of lower AI3 limit	-100.0%~100.0%	-100.0~100.0	0.0%	O	Lower AI3 limit setting	54.
P5.27	Upper AI3 limit	10.00- V ~10.00V	-10.00~10.00	10.00 V	O	Upper AI3 limit	55.
P5.28	Corresponding setting of upper AI3 limit	-100.0%~100.0%	-100.0~100.0	100.0%	O	Upper AI3 limit setting	56.
P5.29	AI3 input filter time	0.00 s~10.00s	0.00~10.00	0.10 s	O	AI3 filter time	57.
P5.30	Lower AI4 limit	0.00 V~10.00V	0.00~10.00	0.00 V	O	Lower AI4 limit	58.
P5.31	Corresponding setting of lower AI4 limit	-100.0%~100.0%	-100.0~100.0	0.0%	O	Lower AI4 limit setting	59.
P5.32	Upper AI4 limit	0.00 V~10.00V	0.00~10.00	10.00 V	O	Upper AI4 limit	60.
P5.33	Corresponding setting of upper AI4 limit	-100.0%~100.0%	-100.0~100.0	100.0%	O	Upper AI4 limit setting	61.
P5.34	AI4 input filter time	0.00 s~10.0 0s	0.00~10.00	0.10 s	O	AI4 filter time	62.
P5.35	HDI1 high-speed pulse input function selection	0: Setting input 1: Counter input 2: Length count input 3: reserved 4: reserved	0~4	0	⊙	HDI1 pulse function	63.
P5.36	HDI2 high-speed pulse input function selection		0~4	0	⊙	HDI2 pulse function	64.
P5.37	Lower HDI1 frequency limit	0.0 KHz ~50.0KHz	0.0~50.0	0.0 KHz	O	Lower HDI1 frequency limit	65.
P5.38	Corresponding setting of lower HDI1 frequency limit	-100.0%~100.0%	-100.0~100.0	0.0%	O	Lower HDI1 limit setting	66.
P5.39	Upper HDI1 frequency limit	0.0 KHz ~50.0KHz	0.0~50.0	50.0 KHz	O	Upper HDI1 frequency limit	67.

Functional Code	Name	Detailed Parameter Description	Setting Range	Default Value	Change	LCD Display	Serial No.
P5.40	Corresponding setting of upper HDI1 frequency limit	-100.0%~100.0%	-100.0~100.0	100.0%	O	Upper HDI1 limit setting	68.
P5.41	HDI frequency input filter time	0.00 s 10.00~s	0.00~10.00	0.10 s	O	HDI1 filter time	69.
P5.42	Lower HDI2 frequency limit	0.0 KHz ~50.0KHz	0.0~50.0	0.0 KHz	O	Lower HDI2 frequency limit	70.
P5.43	Corresponding setting of lower HDI2 frequency limit	-100.0%~100.0%	-100.0~100.0	0.0%	O	Lower HDI2 limit setting	71.
P5.44	Upper HDI2 frequency limit	0.0 KHz ~50.0KHz	0.0~50.0	50.0 KHz	O	Upper HDI2 frequency limit	72.
P5.45	Corresponding setting of upper HDI2 frequency limit	-100.0%~100.0%	-100.0~100.0	100.0%	O	Upper HDI2 limit setting	73.
P5.46	HD2 frequency input filter time	0.00 s~10.00s	0.00~10.00	0.10 s	O	HDI2 filter time	74.
P7.00	User password	0~65535	0~65535	0	O	User password	75.
P7.01	LCD display language selection	0: Chinese 1: English	0~1	0	O	Language	76.
P7.04	STOP/RST stop function selection	0: Valid only for panel control 1: Valid for panel and terminal control 2: Valid for panel and communication control 3: Valid for all control modes	0~3	0	O	STOP functional key	77.
P7.08	Temperature of rectifier module	100.0~0 °C			●	Temperature of rectifier module	78.
P7.09	Temperature of inverter module	100.0~0 °C			●	Temperature of inverter module	79.
P7.12	Accumulative run time of the device	65535~0 h			●	Accumulative run time	80.
P7.13	Type of previous two faults	0: Not fault 1: Phase U protection of inverter unit (OUT1) 2: Phase V protection of inverter unit (OUT2) 3: Phase W protection of inverter unit (OUT3)			●	Fault type 1	81.

Functional Code	Name	Detailed Parameter Description	Setting Range	Default Value	Change	LCD Display	Serial No.
P7.14	Type of the previous fault	4: Acceleration overcurrent (OC1) 5: Deceleration overcurrent (OC2) 6: Constant overcurrent (OC3) 7: Acceleration overvoltage (OV1)			•	Fault type 2	82.
P7.15	Current fault type	8: Deceleration overvoltage (OV2) 9: Constant overvoltage (OV3) 10: Bus under-voltage fault (UV) 11: Motor overload (oL1) 12: Inverter overload (oL2) 13: Input phase failure (SPI) 14: Output phase failure (SP0) 15: Overheat fault of rectifier module (OH1) 16: Overheat fault of inverter module (OH2) 17: External fault (EF) 18: Communication fault (CE) 19: Current detection fault (ITE) 20: Motor self-learning fault (TE) 21: Coder disconnection fault (PCE) 22: Coder reverse direction fault (PCE) 23: System fault (OPSE) 24: FEPROM operation fault (EEP) 25: PID feedback disconnection fault (PIDE) 26: Brake unit fault (BCE) 27: reserved			•	Fault type 3	83.
P7.16	Current fault run frequency				•	Frequency upon fault	84.
P7.17	Current fault output current				•	Current upon fault	85.
P7.18	Current fault bus voltage				•	Bus voltage upon fault	86.
P7.19	Current fault input terminal state				•	Fault input terminal	87.
P7.20	Current fault output terminal state				•	Fault output terminal	88.
P8.16	Number of automatic fault reset operations	0~3	0~3	0	O	Number of fault resets	89.

Functional Code	Name	Detailed Parameter Description	Setting Range	Default Value	Change	LCD Display	Serial No.
P8.17	Action of faulty relay in case of automatic fault reset	0: No action 1: Action	0~1	0	○	Fault action selection	90.
P8.18	Auto fault reset interval setting	100.0~0.1 s	0.1~100.0	1.0 s	○	Fault reset interval	91.
PA.04	Multi-step speed 1	-100.0~100.0%	-100.0~100.0	0.0%	○	Multi-step speed 1	92.
Pb.00	Input phase failure protection	0: protection disabled 1: protection enabled	0~1	1	○	Input phase failure	93.
Pb.01	Output phase failure protection	0: protection disabled 1: protection enabled	0~1	1	○	Output phase loss	94.
Pb.02	Motor overload protection selection	0: Not protected 1: Common motor (with low-speed compensation) 2: Variable frequency motor (without low-speed compensation)	0~2	2	⊙	Motor overload selection	95.
Pb.03	Motor overload protection current	20.5% ~ 120.0% (rated current of the motor)	20.0~120.0	100.0%	○	Overload protection current	96.
Pb.04	Overload alarm point	20.0%~150.0%	20.0~150.0	130.0%	○	Overload alarm point	97.
Pb.05	Overload alarm selection	0: corresponding to the rated current of the motor, tested all the time 1: corresponding to the rated current of the motor, tested at constant speed 2: corresponding to the rated current of the inverter, tested all the time 3: corresponding to the rated current of the inverter, tested at constant speed	0~3	0	⊙	Overload alarm selection	98.
Pb.06	Overload alarm delay time	30.0~0.0 s	0.0~30.0	5.0 s	○	Alarm delay time	99.
Pb.07	Frequency decrease point upon instantaneous power failure	400.0 V~600.0V	400.0~600.0	450.0 V	○	Frequency decrease point upon power failure	100.

Functional Code	Name	Detailed Parameter Description	Setting Range	Default Value	Change	LCD Display	Serial No.
Pb.08	Frequency decrease rate upon instantaneous power failure	0.00Hz~P0.07 (maximum frequency)	0.00 Hz ~ P0.07	0.00 Hz	○	Frequency decrease rate upon power failure	101.
Pb.09	Overvoltage stall speed protection	0: protection disabled 1: protection enabled	0~1	0	○	Overvoltage stall speed protection	102.
Pb.10	Overvoltage stall speed protection voltage	120~150%	120~150	130%	○	Overvoltage stall speed voltage	103.
Pb.11	Overcurrent stall speed protection	0: protection disabled 1: protection enabled	0~1	0	○	Overcurrent stall speed protection	104.
Pb.12	Overcurrent stall speed protection current	100~200%	100~200	150%	○	Overcurrent stall speed current	105.
Pb.13	Overcurrent frequency decrease rate	50.00~0.00 Hz/s	0.00~50.00	0.00 Hz/s	○	Overcurrent decrease rate	106.

## Attachment 2: Standard Wiring Diagram

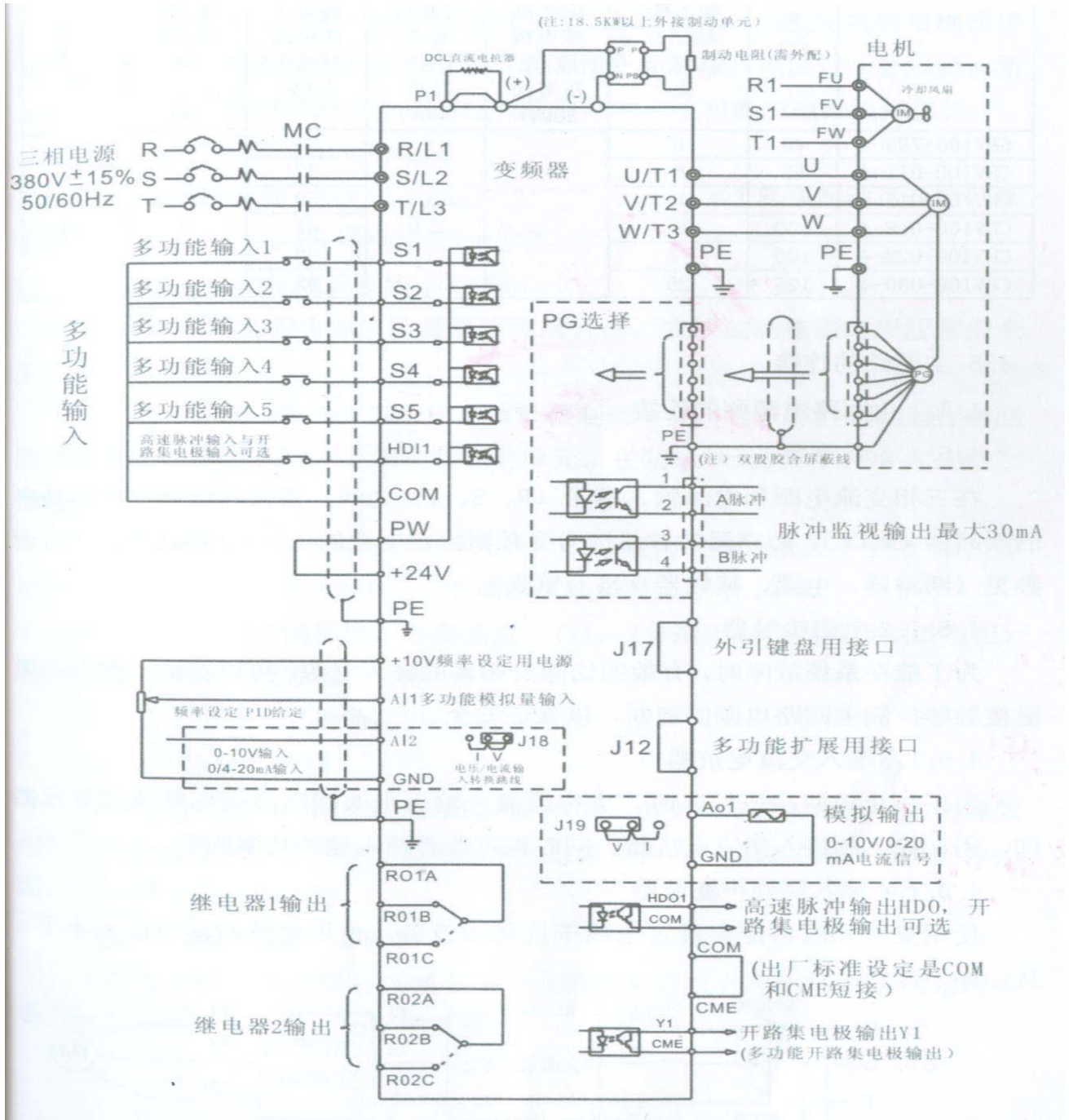

(注: 18.5KW 以上外接制动单元)	(Note: external brake unit in case of over 18.5KW)
DCL 直流电机	DC: DC motor Brake resistor (option)
制动电阻(需外配)	
电机	Motor
冷却风扇	Cooling fan
三相电源	Three-phase power supply
变频器	Inverter
多功能输入	Multifunction input
多功能输入 1	Multifunction input 1
多功能输入 2	Multifunction input 2
多功能输入 3	Multifunction input 3
多功能输入 4	Multifunction input 4
多功能输入 5	Multifunction input 5
高速脉冲输入与开路集电极输入可选	High-speed pulse input and open-circuit collector input (optional)
PG 选择	PG selection
(注: ) 双股胶合屏蔽线	(Note:) twisted pair shielded cable
A 脉冲	Pulse A
B 脉冲	Pulse B
脉冲监视输出最大 30mA	Pulse monitoring output (max: 30mA)
频率设定 PID 给定	Frequency setting by PID
0-10V 输入	0-10V input
0/4-20mA 输入	0/4-20mA input
+10V 频率设定用电源	+10V frequency setting power
AI1 多功能模拟量输入	AI1 multifunction analog input
电压/电流输入转换跳线	Voltage/current input switching jumper
多功能扩展用接口	Multifunction extension interface
模拟输出	Analog output
MA 电流信号	MA current signal
继电器 1 输出	Relay 1 output
继电器 2 输出	Relay 2 output
高速脉冲输出 HD0, 开	High-speed pulse output HD0, open
开路集电极输出可选	Open-circuit collector output (optional)
(出厂标准设定是 COM 和 CME 短接)	(Default setting: COM short-circuited with CME)
开路集电极输出 Y1	Open-circuit collector output Y1
(多功能开路集电极输出)	(Multifunction open-circuit collector output)



## Warranty Card for CHV110 Energy Saver

Card No.: \_\_\_\_\_ - \_\_\_\_\_

Company name					
Company address					
Contact		Department		Title	
Tel		Fax		Postal code	
Model of energy saver			Product number		
Model			Code		
Supplier			Installation date		
Contact			Tel		
Maintainer			Tel		
<p>Through strict quality control and inspected by the quality assurance department, the performance parameters of the product comply with the standard specified in the Operating Instructions delivered with the device, and the product is allowed to leave factory.</p>			<p>Qualification certificate</p>		

- Note: 1. Warranty contents: "A warranty of repair, replacement, or return in one month from the date of shipment; "Repair or replacement in three months from the date of shipment; and "Repair in 18 months from the date of shipment.
- 2 For overseas use (excluding domestic use), the warranty covers repair in the place of purchasing in twelve months from the date of shipment.
3. The warranty of the product shall be based on the warranty card. Please fill in this card upon receipt of the product, and mail it back to our company.