



## VARIABLE SPEED DRIVE UNIT INVERTER

### VAT20

1ph 200V-240V system, 0.2-0.75kW  
1ph/3ph 200/240V system, 1.5-2.2kW

3ph 380/460V system, 0.75-2.2kW

## INSTRUCTION MANUAL

---

### NOTICE

---

1. Read this manual thoroughly before using the VAT20, and store in a safe place for reference.
2. When using this speed drive unit in the EU, compliance with the EMC Directive (89/336/EEC) is required. Check carefully Chapter 2.4. - Installation.
3. The contents of this manual can be changed without notice



## Table of Contents

<b>Foreword</b> .....	3
<b>Chapter 1 Safety Precautions</b>	
1. Precautions of operation.....	4
2. Precautions of operation environment .....	7
<b>Chapter 2 Hardware Instruction and Installation</b>	
1. Operation environment.....	8
2. Type number definitions .....	9
3. Specifications .....	10
4. Wiring .....	12
5. Dimensions & terminal block layout.....	18
<b>Chapter 3 Software Index</b>	
1. Control panel instructions.....	23
2. List of parameters.....	24
3. Parameter function description.....	25
4. Malfunction Indication and countermeasure .....	36
5. General troubleshooting method .....	39
<b>Chapter 4 Maintenance and Peripherals</b>	
1. Maintenance and examiner .....	47
2. Voltage current measurement .....	48
3. Input AC reactor specifications.....	49
4. EMC filter (class B) specifications .....	49
5. DIN-rail specifications.....	49
6. Dynamic braking resistor specifications.....	49

# 1. Foreword

To fully employ all functions of the inverter, and to ensure the safety of users, please read through this operating manual in detail. Should you have any further query, please feel free to contact your local distributor or customer service of GE.

## Precaution

The inverter is a power electronic device, for safety reason, please take special care for paragraphs with “WARNING” or “CAUTION” symbol. They are important safety precautions to be aware of while transporting, installation, operating or examining the inverter. Please following these precaution to ensure your safety.

**⚠ WARNING** Personnel injury may be resulted by improper operation.

**⚠ CAUTION** The inverter or mechanical system may be damaged by improper operation.

<b>⚠ WARNING</b>
<ul style="list-style-type: none"><li>● Do not touch the PCB or components on the PCB right after turning off the power before the charging indicator went off.</li><li>● Do not attempt to wire circuitry while power is on. Do not attempt to examine the components and signals on the PCB while the inverter operating.</li><li>● Do not attempt to disassemble or modify internal circuitry, wiring, or components of the inverter.</li><li>● The grounding terminal of the inverter must be grounded properly with 200V class type III standard.</li><li>● This is a product of the restricted sales distribution class according to EN 61800-3. In a domestic environment this product may cause radio interference in which case the user may be required to take adequate measures.</li></ul>

<b>⚠ CAUTION</b>
<ul style="list-style-type: none"><li>● Do not attempt to proceed dielectric strength test to internal components of the inverter. There are sensitive semiconductor-devices vulnerable to high voltage in the inverter.</li><li>● Do not connect the output terminals: T1(U), T2(V), and T3(W) to AC power outlet.</li><li>● The CMOS IC on the primary PCB of the inverter is vulnerable to static electrical charges. Do not contact the primary PCB of the inverter.</li></ul>

## 2. Examination before installation

Every GE Power Controls inverter has been fully tested and examined before shipment. Please carry out following examination procedures after unpacking your inverter.

- Check to see the model number of the inverter. It should be the one that you ordered.
- Check to see if there is any damage during the transportation. Do not connect the inverter to the power supply if there is any sign of damage.

Report to regional sale representative if you find any abnormal condition as mentioned above.

# Chapter 1. Safety Precautions

## 1.1. Precautions of operation

### Before turning ON power

#### CAUTION

Choose appropriate power source with correct voltage setting as the input voltage specification of the inverter.

#### WARNING

Special care must be taken while wiring the primary circuitry panel. The L1 and L2 terminal must be connected to input power source and must not be mistakenly connected to T1, T2 or T3 terminal. This may damage the inverter when the power is turned on.

#### CAUTION

- 1 Do not attempt to transport the inverter by the front cover. Securely hold the inverter by the heat-sink mounting chassis to prevent the inverter from falling that may cause personnel injury or damage the inverter.
- 1 Install the inverter onto firm metal base or other inflammable material. Do not install the inverter onto or nearby any flammable material to avoid fire.
- 1 Additional cooling fan should be installed if several inverter are installed into one control panel to lower the temperature inside below 40° to avoid overheating or fire alarm.
- 1 Turn off power supply before proceeding removal or installation of operating panel. Carry out installation procedure according to instructions given to avoid poor-contact situation resulting operating panel malfunction or no displaying information.
- 1 Suitable for use on a circuit capable of delivering not more than 5000RMS symmetrical amperes, 240V maximum
- 1 Not proved with over speed Protection or equivalent
- 1 Only intended for use in a pollution degree 2 macro environment or equivalent

## When power is turned ON

### **⚠ WARNING**

- 1 Do not attempt to install or remove connector of inverter when the power supply is turned on. Otherwise, the inverter may be damaged due to the surge peak caused by the insertion or removal.
- 1 When momentary power loss is longer than 2 seconds (the larger of horse power, the longer of time), the inverter does not have enough storage power to control the circuit. Therefore, when power is regenerated, the operation of the inverter is based on the setup of F\_10 and the condition of external switch, this is considered to be 'restart' in the following paragraphs.
- 1 When the momentary power loss is short, the inverter still has enough storage power to control the circuit; therefore, when power is regenerated, the inverter will automatically start operation again depends on the setup of F\_23.  
When restart the inverter, the operation of the inverter is based on the setup of F\_10 and the condition of external switch (FWD/REV button). Attention: the restart operation is irrelevant with F\_23/F\_24.
  - (1) When F\_10=0, the inverter will not start after restart.
  - (2) When F\_10=1 and the external switch (FWD/REV button) is OFF, the inverter will not start after restart.
  - (3) When F\_10=1 and the external switch (FWD/REV button) is ON, the inverter will start automatically after restart. Attention: Base on safety reason, please turn off the external switch (FWD/REV button) after power loss to avoid possible damage to the machine and the human body after sudden regeneration of power.

## Under Operation

### **⚠ WARNING**

Do not switch ON or OFF motor at the middle of operation. Otherwise, the inverter over-current break-down may be resulted.

### **⚠ WARNING**

- 1 Do not remove the front cover of the inverter when the power is ON to avoid personnel injury caused by electrical shock.
- 1 When the automatic restart function is enabled, the motor and machinery will be restarted automatically after fully stop from operation. Do not get close to the machinery to avoid personnel injury.

**⚠ CAUTION**

- 1 Do not touch the heat-sink base.
- 1 The inverter can be easily operated from low-speed to high-speed range. Please reconfirm the operating range of motor and machinery.
- 1 Do not examining the signals on the PCB of the inverter when it is under operation.
- 1 All inverter had been properly adjusted before delivery. Do not attempt to adjust it.

**⚠ CAUTION**

Do not proceed with disassemble or examination procedure before ensuring that the power is off and the Power LED extinguished.

### **During examination and maintenance**

**⚠ CAUTION**

Inverter environment should be within temp:  $-10^{\circ}\text{C} \sim +40^{\circ}\text{C}$ , humidity under 95% RH without condensing.

**⚠ CAUTION**

After the removal of shield sticker, the environment temperature should be within  $-10^{\circ}\text{C}$  and  $+50^{\circ}\text{C}$  and humidity under 95% RH without condensing. Besides, the inverter should be free from water dripping or metal dust.

## 1.2. Precautions of operation environment

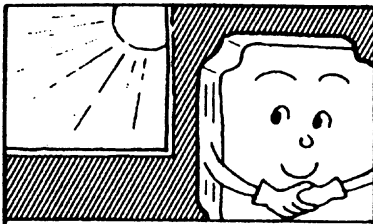

Avoid direct sunlight

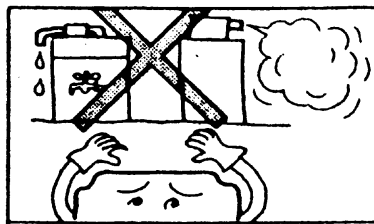

Keep away from corrosive gas or liquid

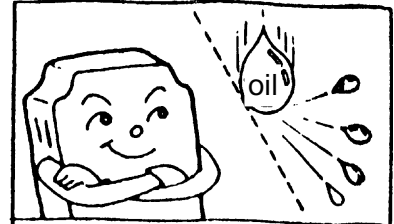

Keep away from oil grease and gas

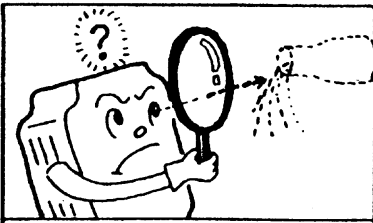

Keep away from salty environment

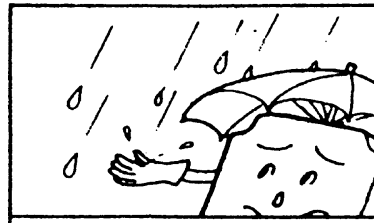

Keep away where rain or dripping water may get into the inverter

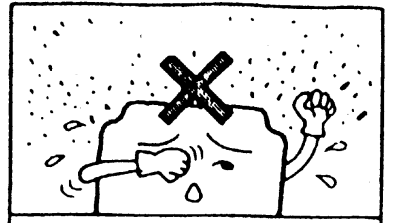

Avoid metal dust and dusty environment

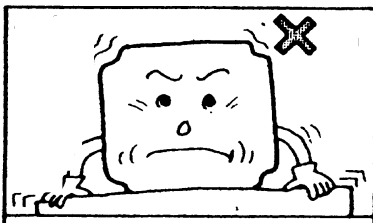

Avoid massive vibration

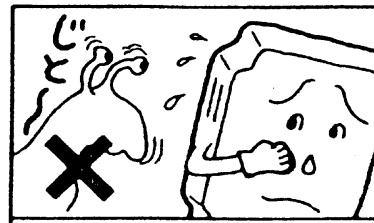

Avoid heat

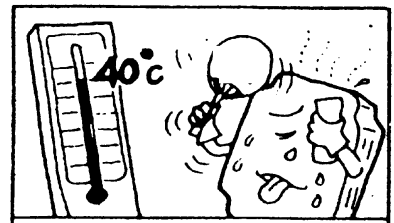

Avoid where environment temperature is too high

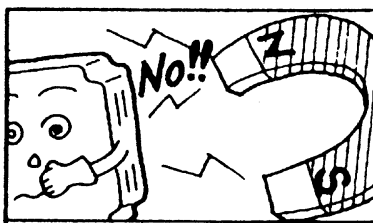

Keep away from high electrical-magnetic wave or ultra-high wave.

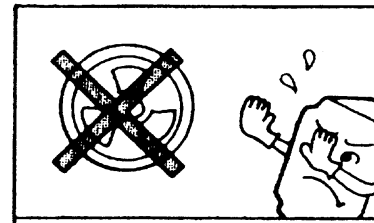

Keep away from radio-active matter

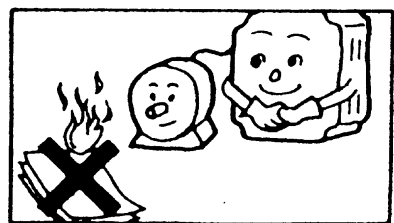

Keep away from flammable material

# Chapter 2. Hardware Instruction and Installation

## 2.1. Operation Environment

The installation site of the inverter pose direct impact to the fully functionality and the life-span of your inverter. Please carefully choose the installation site to meet following requirements:

- 1 Mount the unit vertically
- 1 Environment temperature:  $-10^{\circ}\text{C}$  to  $+50^{\circ}\text{C}$
- 1 Avoid placing close to any heating equipment
- 1 Avoid water dripping or humid environment
- 1 Avoid direct sunlight
- 1 Avoid oil or salty corrosive gas
- 1 Avoid contacting corrosive liquid or gas
- 1 Prevent foreign dusts, flocks, or metal scraps from entering interior
- 1 Away from radioactive matter or flammable material
- 1 Avoid electric-magnetic interference (soldering or power machinery)
- 1 Avoid vibration, if vibration can not be avoided, anti-rattler should be installed to reduce it.
- 1 If inverter is installed in control panel, please tear off shield sticker of VAT20.  
Additional cooling fan should be installed to lower the environment below  $50^{\circ}\text{C}$

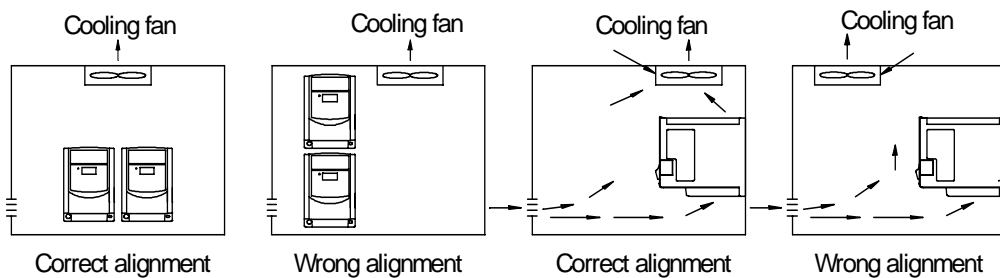

- 1 Installation of the inverter must place the front side of inverter facing front and the top of inverter towards up direction for better heat dissipation.
- 1 Installation rooming must be compliant to following requirement.

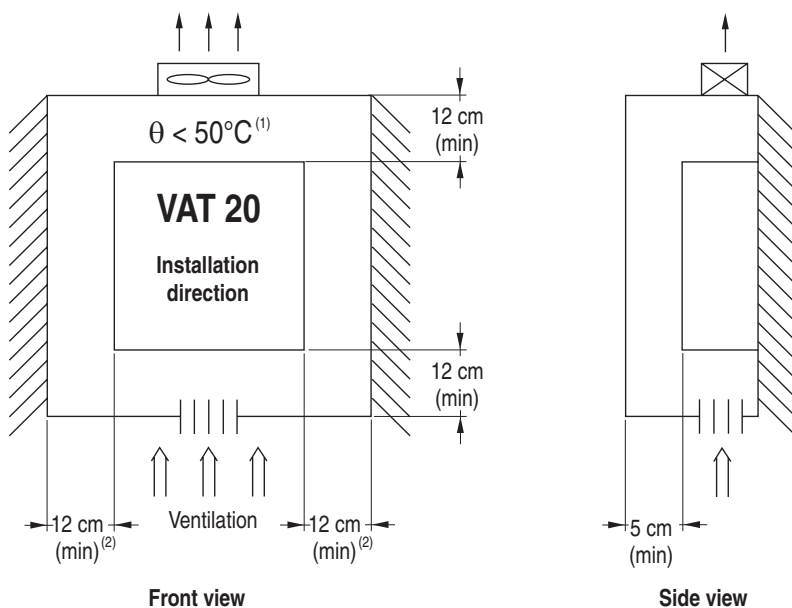

(1) Maximum temperature in the enclosure  $50^{\circ}\text{C}$

(2) Keep 7 cm for following drives: N1K5, N2K2, X0K7, X1K5, X2K2

## 2.2. Type number definitions

Inverter Type → U20N0K7S (for example)

Input Power Rating → I/P: AC 1ph 200 ~ 240V 50/60Hz

Output Rating → O/P: AC 3ph 0 ~ 240V 1.6kVA 4.2A

U20	-	N	-	0K7	-	S
Series		Power Voltage		Power Rated		Option

**N:200V**, 1ph

**N:200V**, 1ph/3ph

**X:400V**, 3ph

0K2: 0.2kW

0K4: 0.4kW

0K7: 0.7kW

1K5: 1.5kW

2K2: 2.2kW

0K7: 0.75kW

1K5: 1.5kW

2K2: 2.2kW

S: Standard model with EMC filter

SX: Standard model without EMC filter

## 2.3. Specifications

### Basic specifications, 200V series

Type No: VAT20-		U20N0K2_	U20N0K4_	U20N0K7_	U20N1K5_	U20N2K2_
Suitable Motor Power Rating (kW)		0.2	0.4	0.75	1.5	2.2
Rated	Motor HP	1/4	1/2	1	2	3
	Current A	1.4	2.3	4.2	7.5	10.5
	Capacity kVA	0.53	0.88	1.6	2.9	4.0
	Weight (kg )	0.76	0.77	0.8	1.66	1.76
Input Voltage Max.		Single phase 200/240V (+10% -15%), 50/60Hz (±5%)			Single/Three phases 200-240V (+10% -15%), 50/60Hz (±5%)	
Output Voltage Max.		Three phase 200/240V +10%-15%				
Dimensions (W x H x D) mm		72x132x118		118x143x172		
EMC specification <sup>(1)</sup>		Class A (single phase filter built in)				

(1) Only for U20N\_K\_S type

### Basic specifications, 400V series

Type No: VAT20-				U20X0K7_	U20X1K5_	U20X2K2_
Suitable Motor Power Rating (kW)				0.75	1.5	2.2
Rated	Motor HP			1	2	3
	Current A			2.3	3.8	5.2
	Capacity kVA			1.6	2.9	4.0
	Weight (kg )			1.66	1.66	1.76
Input Voltage Max.		Three phase 380/460V (+10% -15%), 50/60Hz (± 5%)				
Output Voltage Max.		Three phase 380/460V +10%-15%				
Dimensions (W x H x D) mm				118x143x172		
EMC specification <sup>(2)</sup>		Class A (single phase filter built in)				

(2) Only for U20X\_K\_S type

## Functional specifications

Type No: VAT20-		U20N0K2S	U20N0K4S	U20N0K7S	U20N1K5S	U20N2K2S
					U20X0K7S, 1K5S, 2K2S	
Input Signal Type		PNP type (SOURCE) input				
Control Method		Sinusoidal wave PWM control				
Freq. control	Frequency range	0~120Hz			0~200Hz	
	Resolution	Digital : 0.1Hz (0~99.9Hz) / 1Hz (100~120Hz) Analog: 0.06Hz/60Hz				
	Keyboard setting	Directly setup by ▲ ▼ buttons.				
	External signal setting	0~10V, 4~20mA , 0~20mA				
	Other function	Frequency upper and lower limit				
General control	Carrier frequency	4-8kHz			4-16kHz	
	Accelerate/decelerate time	0.1~ 999 Sec				
	V/F pattern	6 patterns				
	Torque control	Torque boost level adjustable (manual torque boost)				
	Multi-function input	2 point, to be used as multi-speed 1(Sp1) / Jog / External emergency stop / External reset			2 point, to be used as multi-speed 1(Sp1) / multi-speed 2 (Sp2) / Jog / External emergency stop / External reset	
	Multi-function output	1a Relay terminal, to be setup as Fault / Running / Frequency.				
	Braking torque	About 20%. Not allowable external braking resistor.			100% with external resistor	
	Other function	Decelerate or free run stop, Auto reset, DC braking frequency / Voltage / Time can be setup by constants.				
Display		3 digital LED display frequency / inverter parameter / fault record / program version				
Indication function		7 segments*3 indicate frequency / inverter parameter / fault record / program version.				
Operating temperature		-10 to +40°C (without shield sticker: -10 to +50°C)				
Humidity		0~95% RH non-condensing.				
Vibration		Under 1 G ( 9.8 m/s <sup>2</sup> )				
EMC specification		EN 5008-1, EN 5008-2, EN 50082-1, EN 50082-2, EN 50178				
Protection level		IP20				
UL		UL508C				
Protection function	Overload protection	150% for 1min.				
	Over-voltage	DC voltage > 410V (200V series), DC > 800V (400V series)				
	Under voltage	DC voltage < 200V (200V series), DC < 400V (400V series)				
	Momentary power-loss	0 ~ 2 sec : VAT20 can be restart by speed search				
	Stall prevention	Accelerate / Decelerate / Constant speed				
Protection function	Output terminal short-circuit	Electronic circuitry protection				
	Grounding fault	Electronic circuitry protection				
	Other function	Heat sink protection , Current limit				
Dimensions (WxHxD) mm		72x132x118			118x143x172	
Installation		Install by mounting screw or DIN rail (Option).				

## 2.4. Wiring

### Moulded-Case Circuit Breaker / Contactor

1 **GE Power Controls maintenance and service do not apply to damage caused by following situation:**

- (1) Damage to the inverter caused by the lack of appropriate molded-case circuit breaker or a circuit breaker with too large capacity is installed in between the power supply and the inverter.
- (2) Damage to the inverter caused by the serial magnetic contactor, phase advancing capacitor, or surge-protector in between the inverter and the motor.

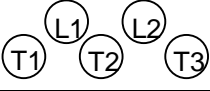
Type No: U20N	0K2, 0K4, 0K7	1K5, 2K2	
Type No: U20X			0K7, 1K5, 2K2
Moulded-case circuit breaker Made by GE	20A	30A	30A
Magnetic Contactor (MC)	Made by GE CL00	Made by GE CL00	Made by GE CL00
Primary Circuit Terminal (TM1) 	Wire dimension 2.5 mm <sup>2</sup> Terminal screw M3	Wire dimension 4 mm <sup>2</sup> Terminal screw M3	Wire dimension 2.5 mm <sup>2</sup> Terminal screw M3
Signal Terminal (TM2) 1~11	Wire dimension 0.75mm <sup>2</sup> (#18 AWG), Terminal screw M3		

- 1 **Please utilize three-phase squirrel-cage induction motor with appropriate capacity.**
- 1 **If a inverter is used to drive more than one motor, the total capacity must be smaller than the capacity of the inverter. Additional thermal relay must be installed in front of every motor. Use the Fn\_18 at 1.0 times of the rated value specified on the motor nameplate at 50Hz, 1.1 times of the rated value specified on the motor nameplate at 60Hz.**
- 1 **Do not install phase advancing capacitor, LC, or RC component between the inverter and the motor.**

## Application and precautions of peripherals

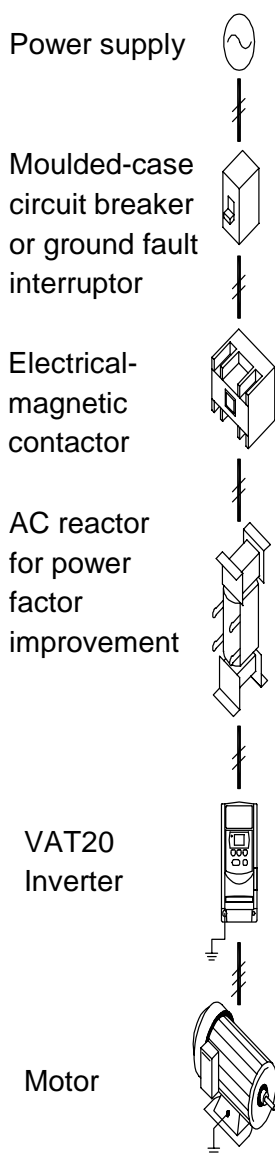

### Power Source

- 1 Ensure to apply power source at correct rated voltage to prevent from damaging the inverter.
- 1 Circuit breaker must be installed in between the AC power supply and the inverter.

### Moulded-case circuit breaker (MCCB)

- 1 Utilize appropriate circuit breaker suitable for the rated voltage and current ratings of the inverter to switch ON/OFF the power supply to the inverter and as a protection for the inverter.
- 1 Do not operate the circuit breaker to switch ON or OFF the inverter.

### Earth leakage circuit breaker (Residual current device)

- 1 Leakage circuit breaker should be added to prevent false operation cause by leakage current and to ensure personnel safety.

### Magnetic Contact

- 1 The Magnetic Contact can be omitted at ordinary operation. To utilize external control, automatic restart, or breaking controller the magnetic contact must be added at the primary side.
- 1 Do not operate the magnetic contact to switch ON or OFF the inverter.

### Power improvement AC Reactor

- 1 If large capacity power source is applied (over 600kVA), additional AC reactor may be added to improve power factor.

### Inverter

- 1 Power supply input terminals L1 and L2 is not differentiated on phase sequence, they can be arbitrarily connected. Their connection may be exchanged.
- 1 Output terminal T1, T2, and T3 should be connected to the U, V, and W terminals of the motor respectively. If motor turns in opposite direction of the inverter, simply exchanging two of three wire connection may correct this problem.
- 1 Output terminal T1, T2, and T3 must not be connected to power source to prevent from damaging inverter.
- 1 Grounding terminal. Properly ground the grounding terminal in compliance to local codes

- (A) External wiring should be carried out in accordance with following requirement. Check and reassure the wiring is correct after the wiring is complete. (Do not utilize the control circuitry buzzer to check the wiring.)

**EMI connecting:**

It is very important that the connections between the frequency inverter with the screened motor cable and the EMI filter during the EMI tests are as following.

- 1 Use a metal grounding plate and place the frequency inverter and the EMI filter on the plate.
- 1 Use a screened motor cable with 4 connectors ( U,V,W,& Earth ), don't use the shielding as safety earth ( shield is high frequency earth )
- 1 Remove painting around the two metal coupling nut holes. So that the metal coupling nuts (and the shielding) make contact with the frequency inverter and the motor.
- 1 Don't solder a conductor to the shielding (pig tail)
- 1 Use a metal clamp to connect the shielding from the motor cable with the metal grounding plate. Now there is a perfect high frequency earth connection between frequency inverter . grounding plate and EMI filter.
- 1 Keep the distance between frequency inverter and EMI filter as short as possible ( < 30cm ) otherwise use screened cable with a metal coupling nut and a metal clamp addle to connect the shielded cable to the frequency inverter and metal grounding plate.
- 1 The only earth connection between the LISN and the test plate should be via the EMI filter.
- 1 Use a motor which equals the power rating or below of the inverter rating.
- 1 Install a noise filter for inverter onto the output side of the primary circuitry can suppress conducting noise (for residential environment only). To reduce radio active noise, use a shielded wire between motor and drive, this wiring should be away from control wiring for more than 30 cm.

Class B, Residential Environment

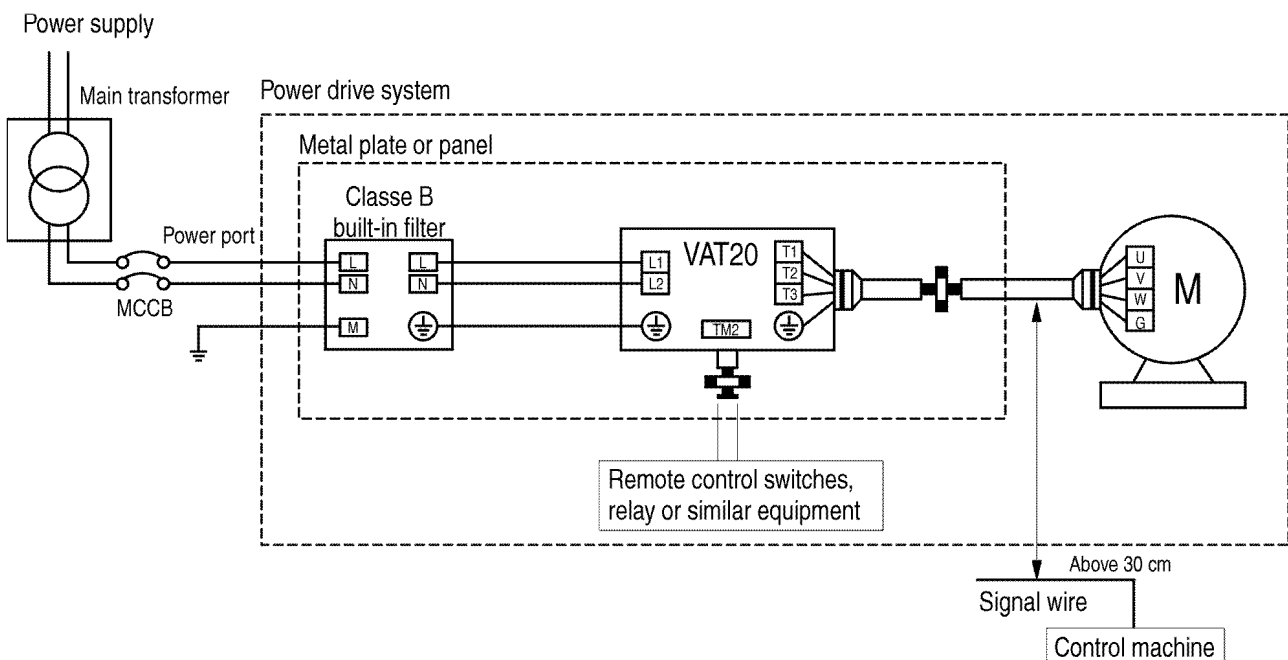

Class A, Industrial Environment (only for drives with built-in EMC class A filter, U20----S)

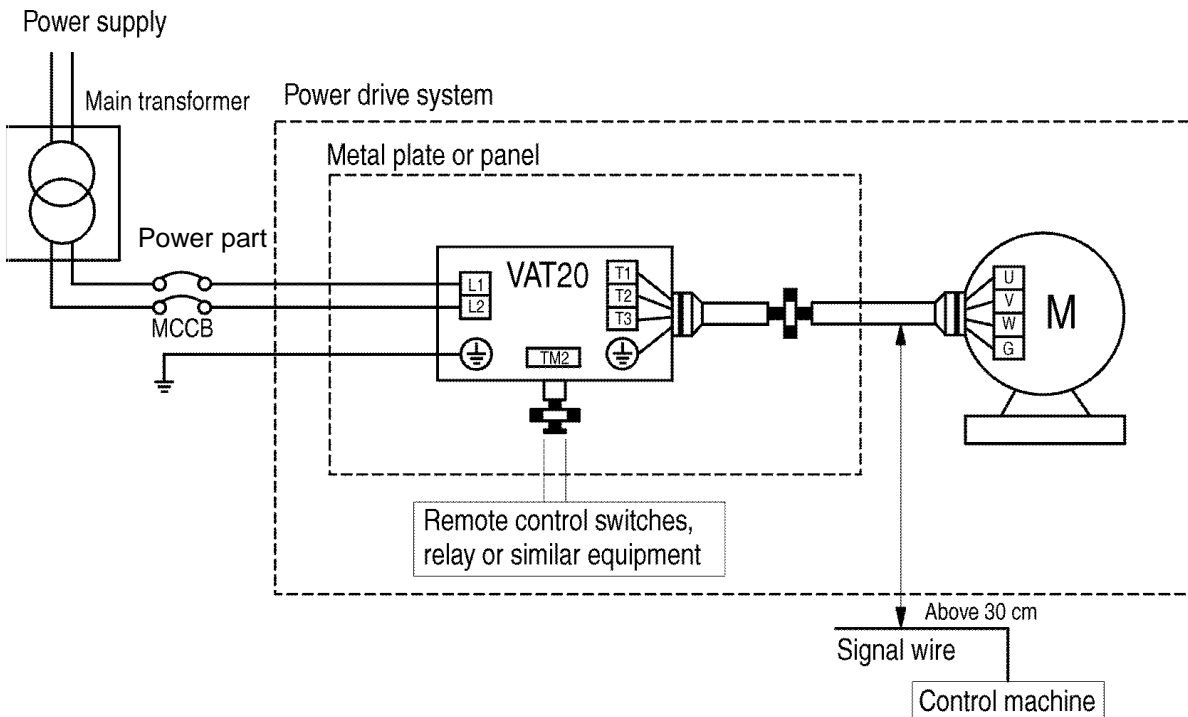

- 1 When the distance between the inverter and motor is longer than 100m, connection wire should be carefully chosen to reduce the wiring resistance below 3% and the voltage drop (V) =  $\sqrt{3} \times \text{Wire resistance } (\Omega/\text{km}) \times \text{wire length (m)} \times \text{current} \times 10^{-3}$

(B) Control circuitry wiring must be separated and away from the primary circuitry control line and other high-voltage or large-current power lines to avoid noise interference.

- 1 To reduce the noise interference and avoid mistake operation, shielded twisted pair cable must be used to wire the control circuitry. Please refer to following diagram. Connect the shielding wire onto the grounding terminal.

**Wiring distance must be under 50m.**

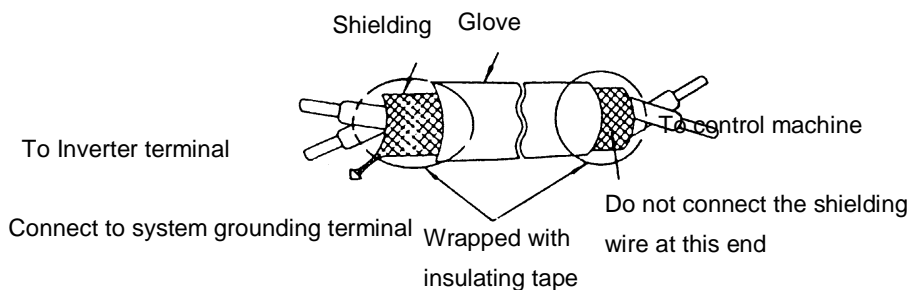

(C) The grounding terminal of the inverter must be correctly grounded in compliance with 200V class type three grounding.

- 1 Grounding wire should be wired in accordance to electrical equipment (AWG) with the length of the grounding wire as short as possible.
- 1 The grounding wire of the inverter must not be grounded together with other large current loading (such as soldering machine or large power motor). They should be grounded separately.

1 Grounding circuitry must not be formed when grounding several inverters together.

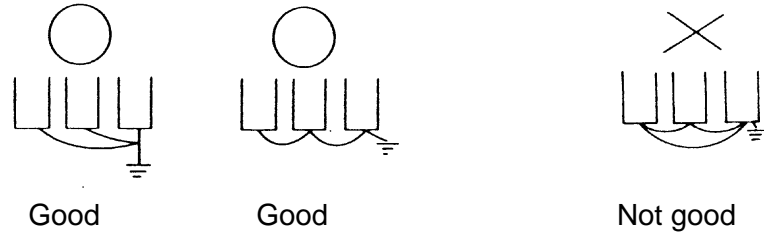

- (D) Wire specification Choose appropriate wire with correct diameter for primary power circuitry and control circuitry in accordance with electricity regulations.
- (E) Upon completion, check out to reassure the wiring correctness, broken wires, and secure terminal screws.

### Wiring Diagram

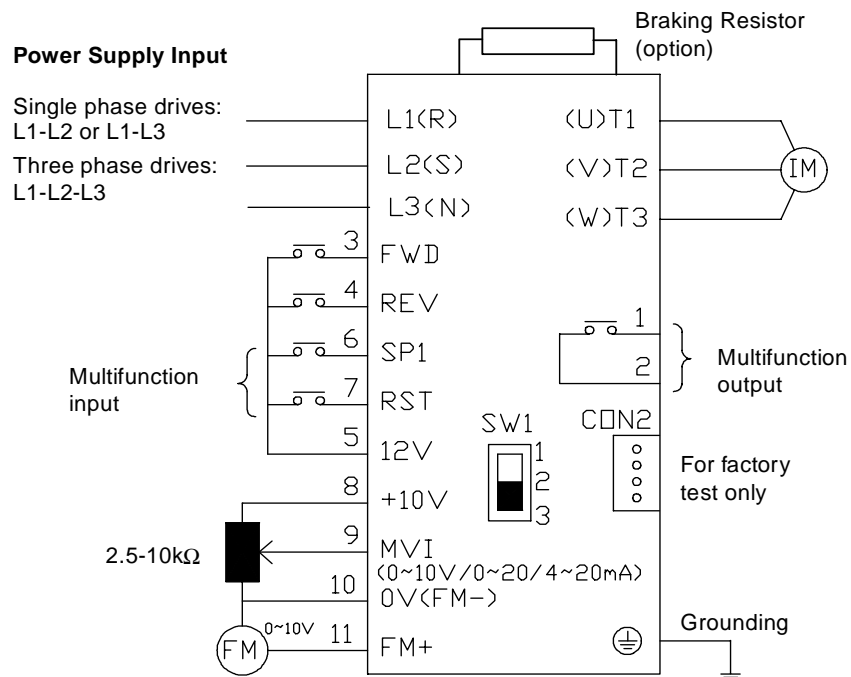

Terminations to Inverter must be made with either UL listed field wiring lug kits or UL listed crimp type ring terminals

Note: only for U20-N1K5/N2K2 and U20-X0K7/X1K5/X2K2

1 Other connections(external 24V supply)

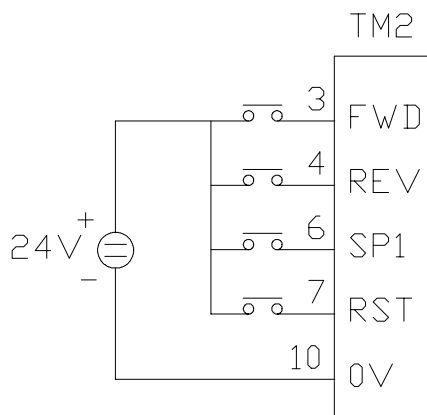

## VAT20 series inverter terminal descriptions

### Primary circuitry terminal block (TM1) descriptions

Terminal symbol	Function description
L1 (R)	Primary power source input to drive Single phase (1ph) drives: L1, L2 or L, N Three phase (3ph) drives: L1, L2, L3
L2 (S)	
L3/N (T)	
P	External braking resistor terminals (Only for U20-N1K5/N2K2 and U20-X0K7/X1K5/X2K2)
R	
T1 (U)	Inverter output to motor
T2 (V)	
T3 (W)	

\* Tightening torque for TM1 is 0.98, or 12 LBS-IN (U20-N0K2/N0K4/N0K7).

\* Tightening torque for TM1 is 1.3 or 16 LBS-IN (U20-N1K5/N2K2 and U20-X0K7/X1K5/X2K2)

\* Wire voltage rating must be a minimum of 300V (200V series)/600V (400V series)

### VAT20 control circuitry terminal block ( TM2 ) description

Terminal symbol		Terminal function description	
1	TRIP	Fault relay output terminal	
2	RELAY	Connection point rated capacity 250VAC/1A ( 30VDC / 1A )	
3	FWD	Operation control terminals (refer to Fn_03)	
4	REV		
5	+ 12V	Common point of terminal 3 / 4 / 6 / 7	
6	SP1	Multifunction input terminals (refer to Fn_19)	
7	RESET		
8		+10V	Power terminal of potentiometer ( Pin 3 )
9		Analog input point	Analog frequency signal input terminal ( Pin 2 of potentiometer or positive terminal of 0~10V / 4~20mA / 0~20mA)
10		0V (FM -)	Analog common point
11	FM+	Analog output positive connection point	Analog frequency signal output terminal Output terminal signal is 0 ~ 10VDC/Fn6

\* Tightening torque for TM2 is 0.4 Nm or 5.03 LBS-IN.

\* Wire voltage rating must be a minimum of 300V for 200V inverters and minimum 600V for 400V inverters

\* Control wiring should not run in the same conduit or race way with power or motor wiring

\* Single Input and Output Terminals (TM2) Ratings are **all** Class 2

## SW1 function description

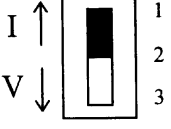
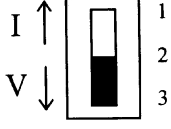
SWITCH 1	External signal type
	<p>0~20mA analog signal ( When Fn11 set to 1 )</p> <p>4~20mA analog signal ( When Fn11 set to 2 )</p>
	<p>0~10 VDC analog signal ( When Fn11 set to 1 )</p>

## 2.5. Dimensions and terminal block layout

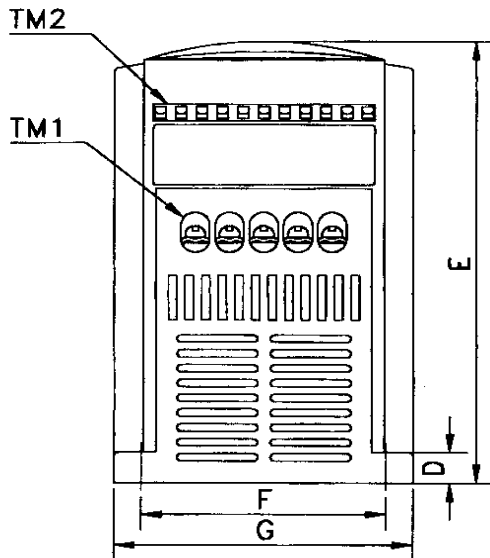
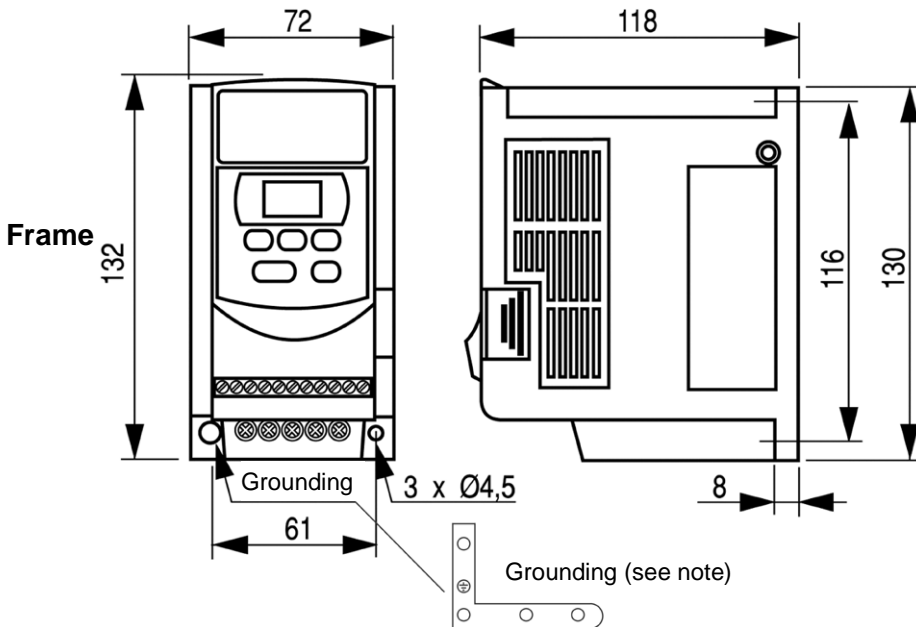

Type	Length			
	D	E	F	G
U20N0K2	8.2	118	61	72
U20N0K4				
U20N0K7				

### NOTE

For safety reason, we strongly recommend users to remove the M4 'green' grounding screw, then screw the enclosed 'metal frame grounding terminal' on the same location to make a grounding bar to ensure good earth protection.

**Frame 2: U20N1K5, U20N2K2, U20X0K7, U20X1K5, U20X2K2**

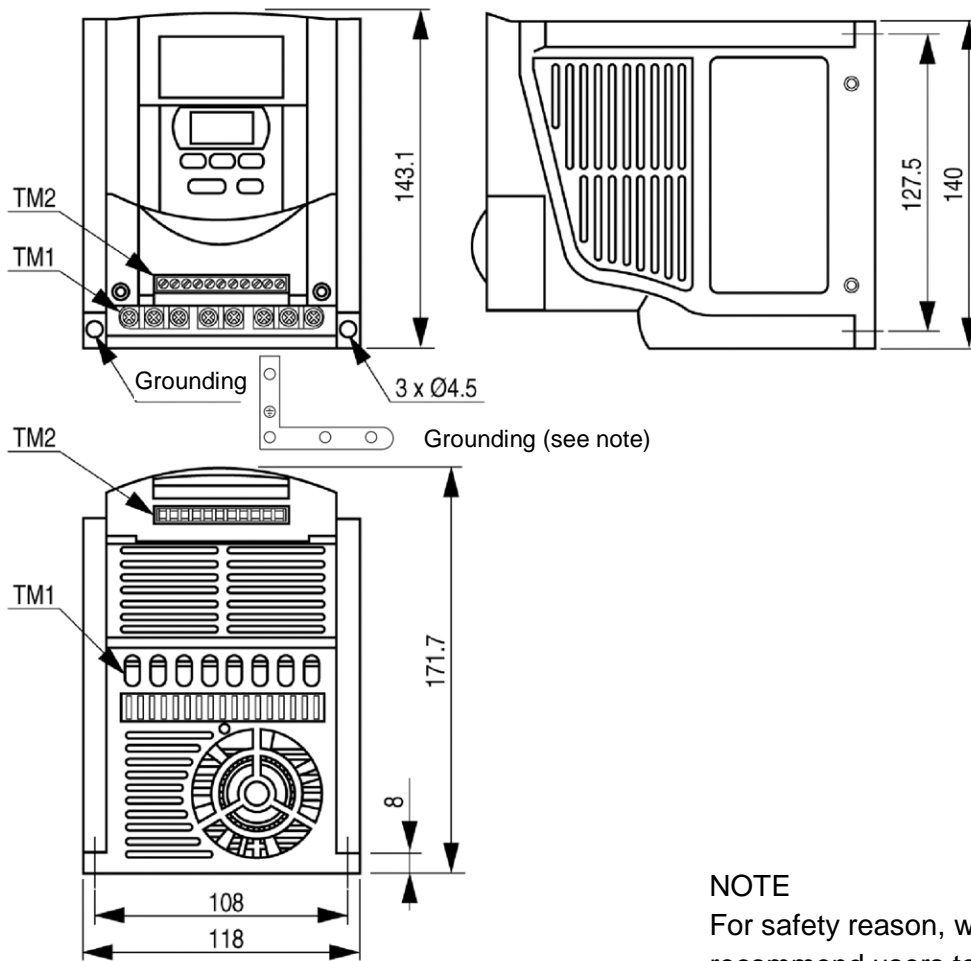

**NOTE**

For safety reason, we strongly recommend users to remove the M4 'green' grounding screw, then screw the enclosed 'metal frame grounding terminal' on the same location to make a grounding bar to ensure good earth protection.

## Dimensions and Installation of class B filter (U20AF0K7)

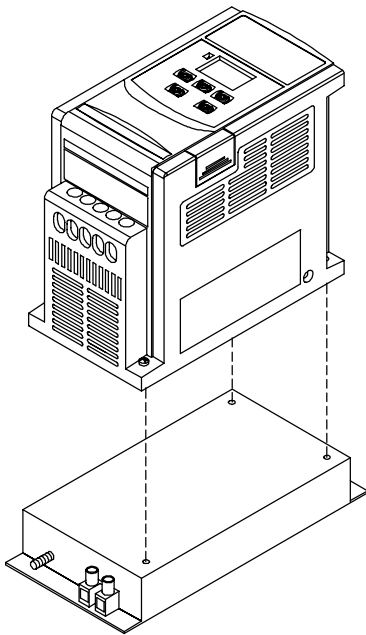
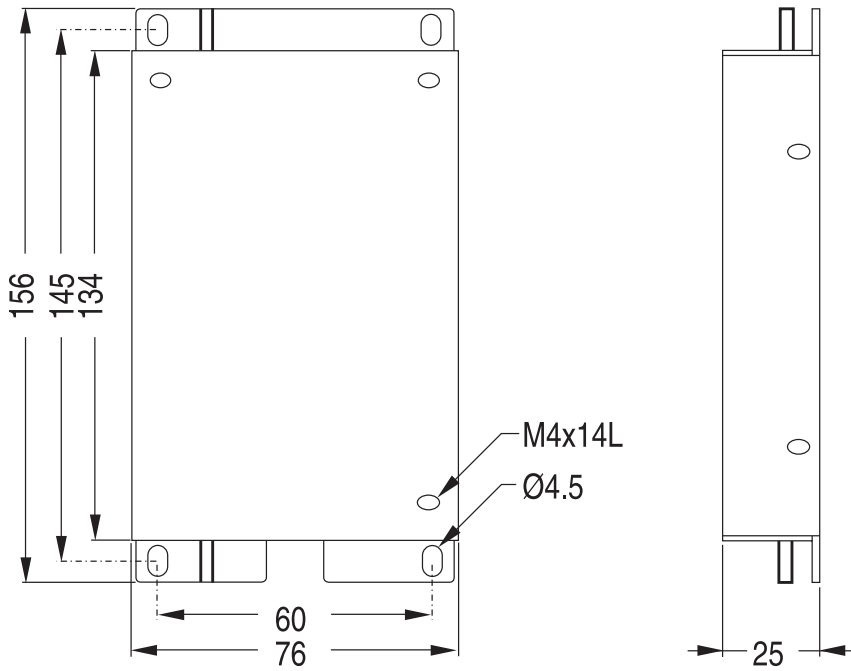

Inverter with class B filter (U20AF0K7) mounted.

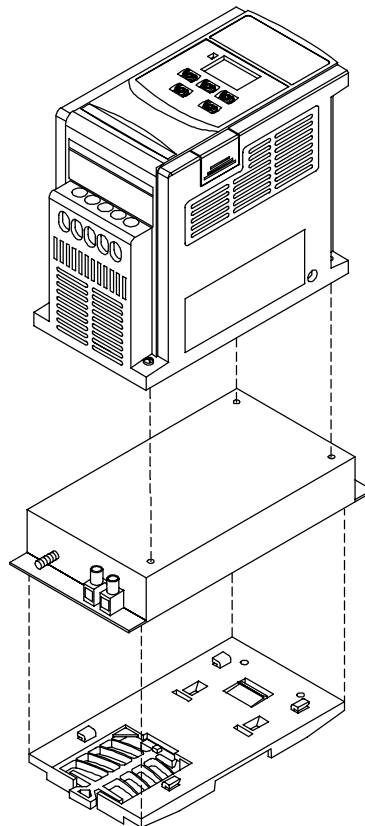

Inverter with class B filter (U20AF0K7) and DIN rail (U20AR0K7) mounted.

## Mounting screw operation diagram

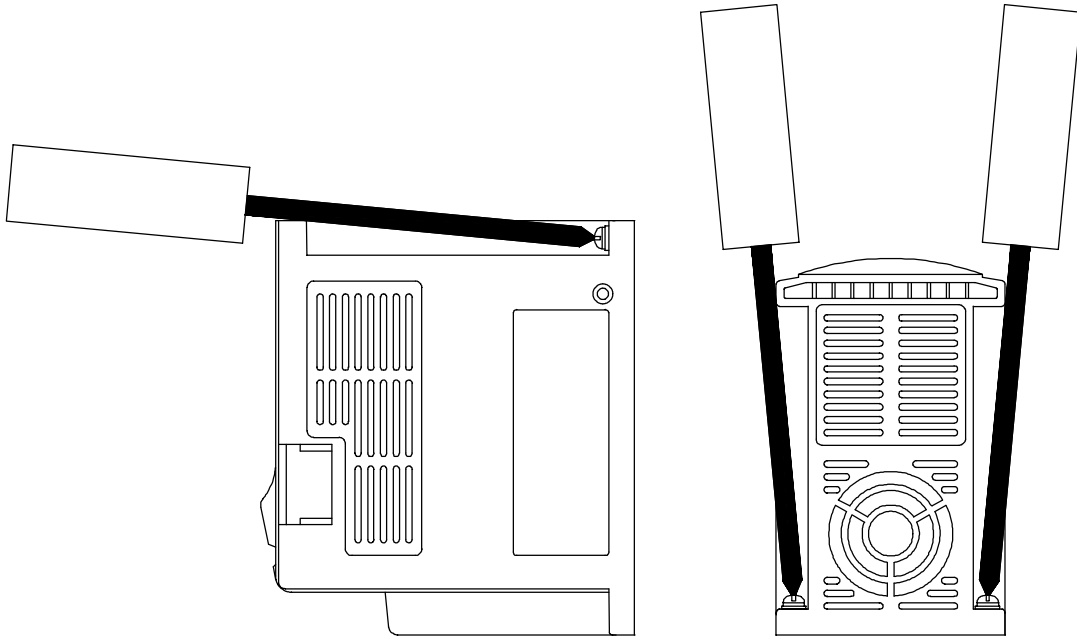

## DIN rail (U20AR0K7) operation diagram

**Step 1**  
Aim and insert the 4 retention ribs of U20AR0K7 at the 4 holes in rear panel of VAT20 .

**Step 2**  
Push the U20AR0K7 forward until the middle rib grips firmly with rear panel

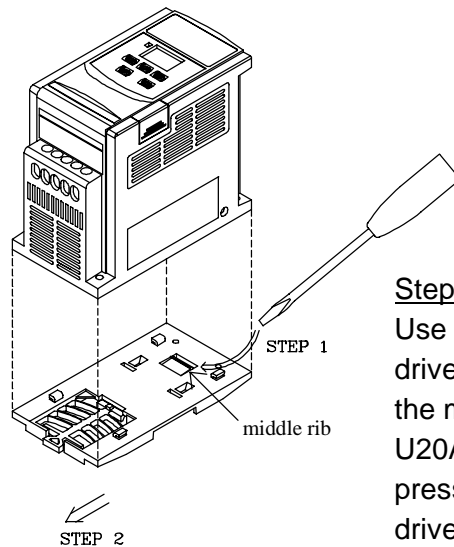
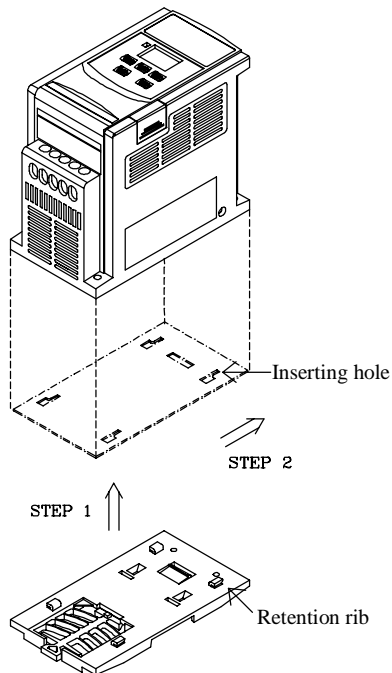

**Step 1**  
Use small screw driver inserting the middle rib of U20AR0K7 and press the screw driver in order to strip U20AR0K7 from VAT20.

## DIN rail installation

Mounting clamp and 35 mm width rail must be used to install VAT20 on the rail.

Install VAT20

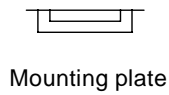
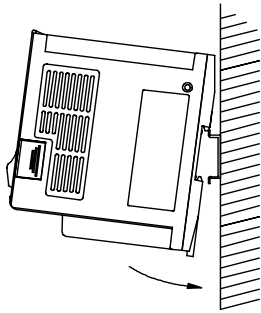

Mounting plate

Dismounting VAT20

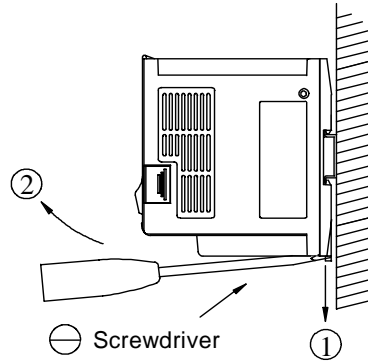

Screwdriver



Pull mounting plate

First place the groove on the back of module on the upper edge of din rail , and then push the module down to lock up position. Finally press the mounting plate upward into module.

- ① Pull the mounting plate downward.
- ② Rotate the T-verter module to dismount it.

Mount

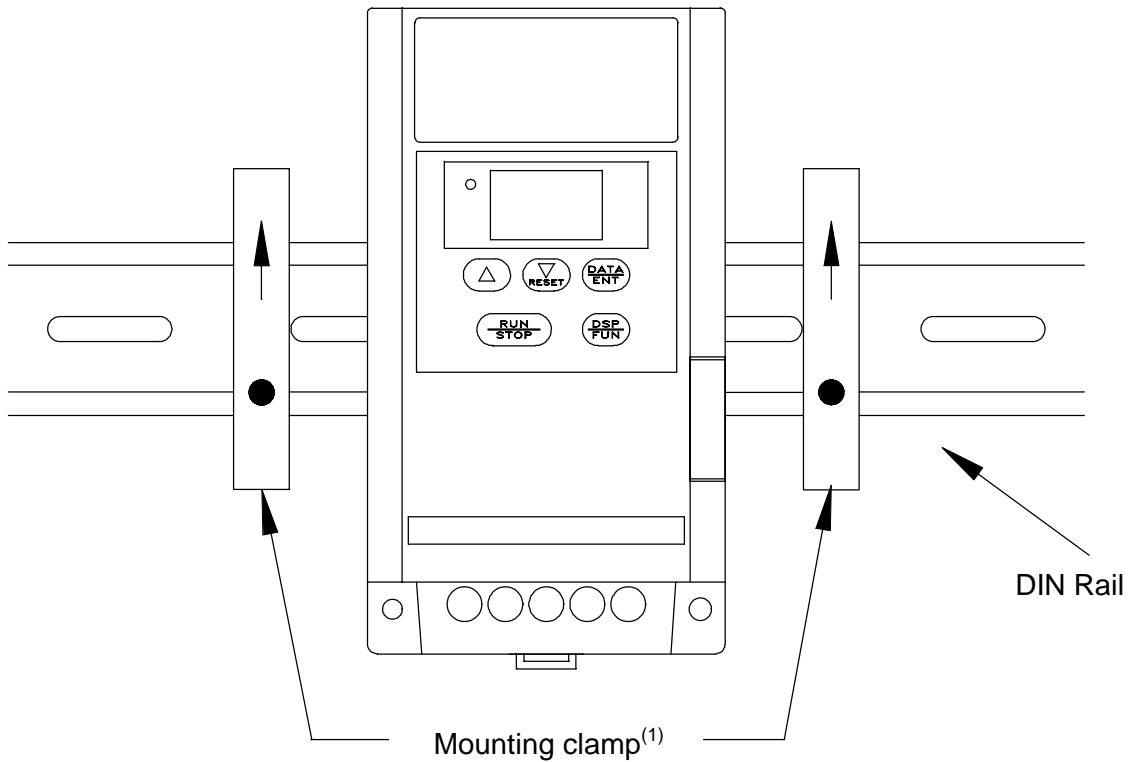

DIN Rail

Mounting clamp<sup>(1)</sup>

(1) Mounting clamp must be used to fasten VAT20

# Chapter 3. Software Index

## 3.1. Control Panel Instructions

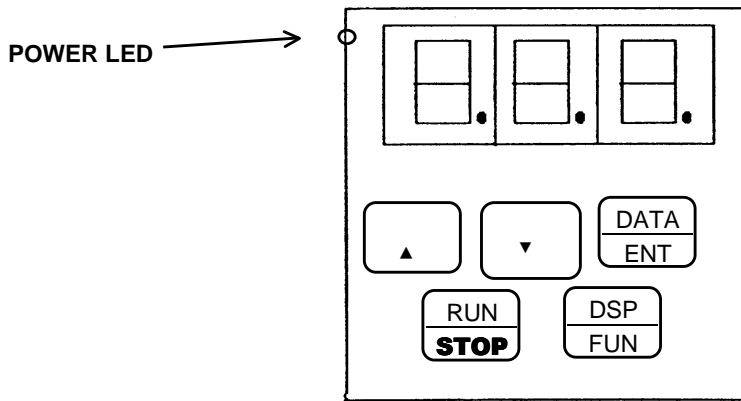

### ⚠ CAUTION

Do not operate keypad by screwdriver or other sharp-ended tool to avoid damaging keypad.

### Brief keypad operation flowchart

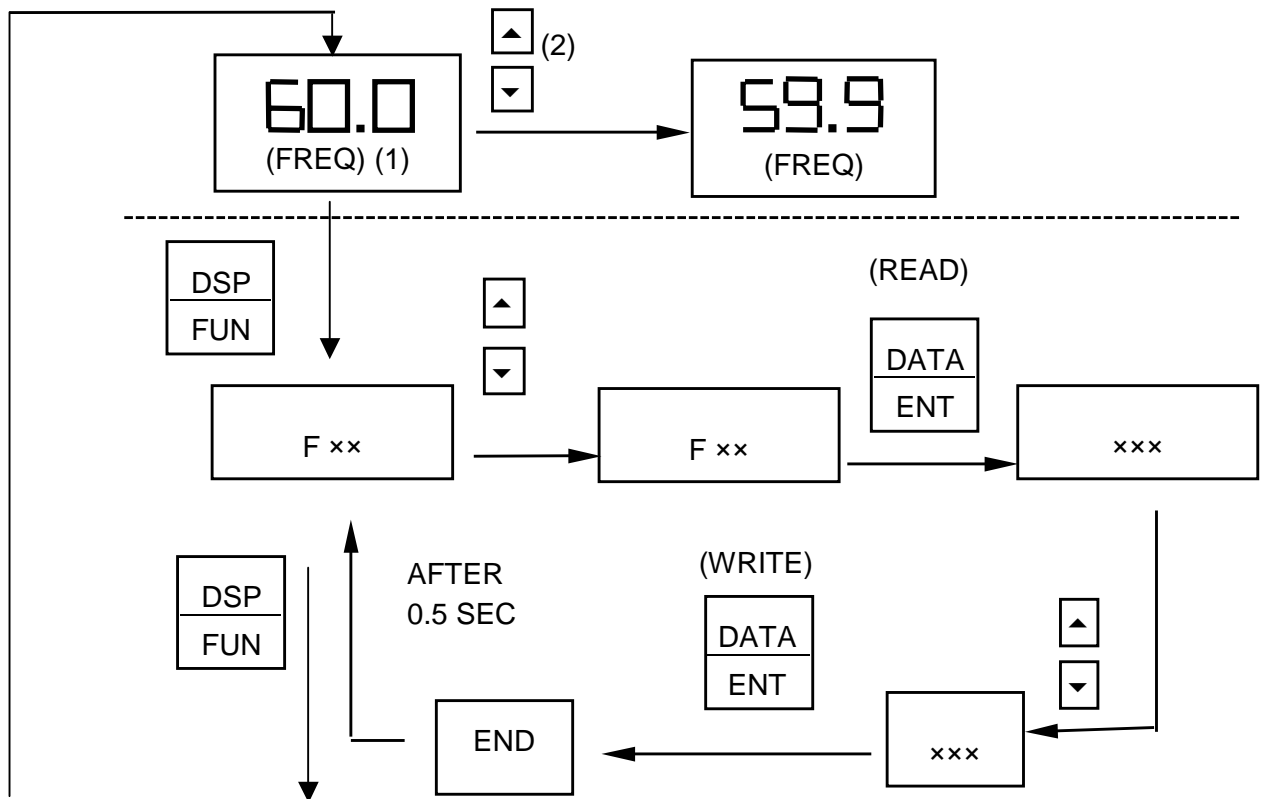

(1) Displayed setting frequency when stopped. Display output frequency when running.

(2) The setting frequency can be modified either when stopped or when running.

### 3.2. List of parameters

Function	FN_	Function Description	Unit	Range	Factory setting	Note
	0	Factory Adjustment			0	
Accelerate / Decelerate Time	1	Accelerate time	0.1 sec	0.1 ~ 999 S	5.0	(1)(3)
	2	Decelerate time	0.1 sec	0.1 ~ 999 S	5.0	(1)(3)
Operation mode	3	0: Forward / Stop, Reverse / Stop 1:Run/Stop, Forward / Reverse	1	0 ~ 1	0	
Motor direction	4	0: Forward 1: Reverse	1	0 ~ 1	0	(1)
V/F Pattern	5	V/F pattern setting	1	1 ~ 6	1/4	(2)
Frequency upper/lower limit	6	Frequency upper limit	0.1Hz	1.0 ~ 120Hz 1.0 ~ 200Hz	50/60Hz	(2)(3) (4)
	7	Frequency lower limit	0.1Hz	0.0 ~ 120Hz 0.0 ~ 200Hz	0.0Hz	(3) (4)
SPI frequency	8	SP1 frequency	0.1Hz	1.0 ~ 120Hz 1.0 ~ 200Hz	10Hz	(3) (4)
JOG frequency	9	JOG frequency	0.1Hz	1.0 ~ 120Hz 1.0 ~ 200Hz	6Hz	(4)
Operation control	10	0:keypad 1: external terminal	1	0 ~ 1	0	
Frequency control	11	0:keypad 1:external terminal(0~10v/0~20mA ) 2: external terminal ( 4~20mA )	1	0 ~ 2	0	
Carrier frequency	12	Carrier Frequency setting	1	1 ~ 5 1 ~ 10	5	(4)
Torque compensation	13	Torque compensation gain	0.1%	0.0 ~ 10.0%	0.0%	(1)
Stop method	14	0:decelerate stop, 1:free run stop	1	0 ~ 1	0	
DC braking setting	15	DC braking time	0.1S	0.0 ~ 25.5S	0.5S	
	16	DC braking injection frequency	0.1Hz	1 ~ 10Hz	1.5Hz	
	17	DC braking level	0.1%	0.0 ~ 20.0%	8.0%	
Electronic thermal	18	Protection on motor rated current	1%	50 ~ 100% (0-200)	100%	(4)
Multifunction input connection point	19	Multifunction input terminal 1 function	1: Jog 2: Sp1 3: Emergency stop 4: External Base Block		2	
	20	Multifunction input terminal 2 function	5: Reset 6: Sp2		5	(4)
Multi-function output	21	Multifunction output terminal	1: Operating 2: Frequency reached 3: Fault		3	
Reverse instruction	22	0: REV run enabled 1: REV run disabled	1	0 ~ 1	0	
Momentary power loss	23	0: enabled 1: disabled	1	0 ~ 1	0	
Auto restart	24	Number of Auto-restart times	1	0 ~ 5	0	
Factory setting	25	010: Constants initialization to 50Hz system 020: Constants initialization to 60Hz system				(2)
SP2 frequency	26	Frequency SP2	0.1Hz	1.0 ~ 200Hz	20	(4)
SP2 frequency	26	Frequency SP3	0.1Hz	1.0 ~ 200Hz	30	(4)
Direct start	28	0: enable 1: disable	1	0 ~ 1	1	(5)
Software version	29	CPU program version				
Fault trace	30	Last 3 malfunction memory				

(1) Indicate this parameter can be adjusted during running mode

(2) Please refer to Fn\_25

(3) If the setting range is above 100, the setting unit becomes 1.

(4) Only for drives with CPU version from 1.9 (check function F\_29)

(5) Only for drives with CPU version from 2.1 (check function F\_29)

### 3.3. Parameter function description

**Fn\_00 Factory adjustment parameter. Do not change.**

**Fn\_01 : Accelerate time = 0.1 up to 999 sec**

**Fn\_02 : Decelerate time = 0.1 up to 999 sec**

#### 1. Accelerate/decelerate time calculation formula:

$$\text{Accelerate time} = \text{Fn\_01} \times \frac{\text{Setting Frequency}}{60 \text{ Hz}}$$

$$\text{Decelerate time} = \text{Fn\_02} \times \frac{\text{Setting Frequency}}{60\text{Hz}}$$

**Fn\_03 : Operation mode selection =**  
**0 : Forward / Stop , Reverse / Stop**  
**1 : Run / Stop , Forward / Reverse**

*Note 1: Fn\_03 take effect only when Fn\_10 = 1 (external operation control)*

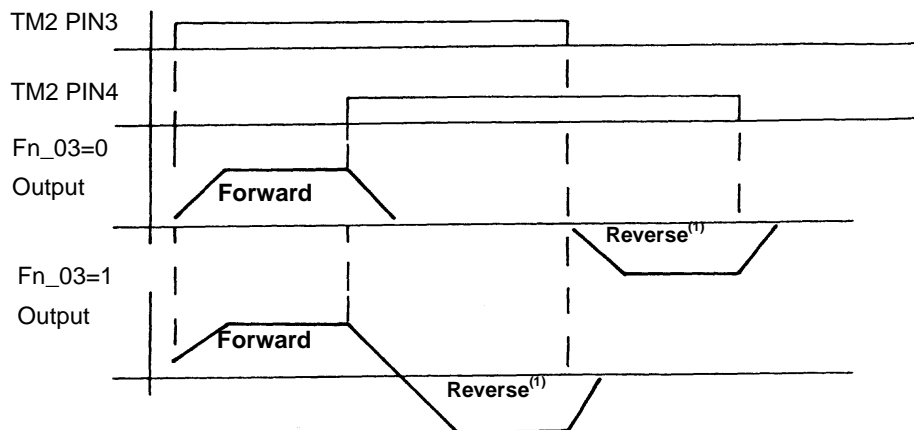
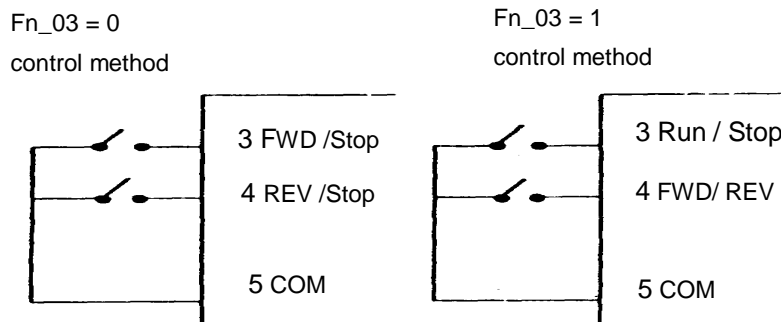

(1) Reverse command is ignored when Fn\_22 = 1

**Fn\_04 : Motor rotation direction setting = 0 : forward  
1 : reverse**

Although there is no Forward/Reverse push button on the digital control panel, it is possible to adjust forward/reverse function by changing Fn\_04 setting.

**Note:**

When Fn\_22 =1: Reverse disabled, the Fn\_04 can not be set to 1. Then keypad indication would display “LOC”.

**Fn\_05 : V/F pattern setting = 1 up to 6**

Adjust Fn\_05 = 1-6 to select one of six fixed V/F pattern. (refer to following tables)

Specification	50 Hz system		
Application	General application	High starting torque	Decreasing torque
Fn_5	1	2	3
V/F pattern			
Specification	60Hz system		
Application	General application	High starting torque	Decreasing torque
Fn_5	4	5	6
V/F pattern			

Fn_5	B	C
1/4	10%	8%
2/5	15%	10.5%
3/6	25%	7.7%

**Fn\_06 : frequency upper limit = 1 up to 120Hz or 200Hz<sup>(\*)</sup>**

**Fn\_07 : frequency lower limit = 0 up to 120Hz or 200Hz<sup>(\*)</sup>**

(\*) Only for with CPU version from 1.9 (check function F\_29)

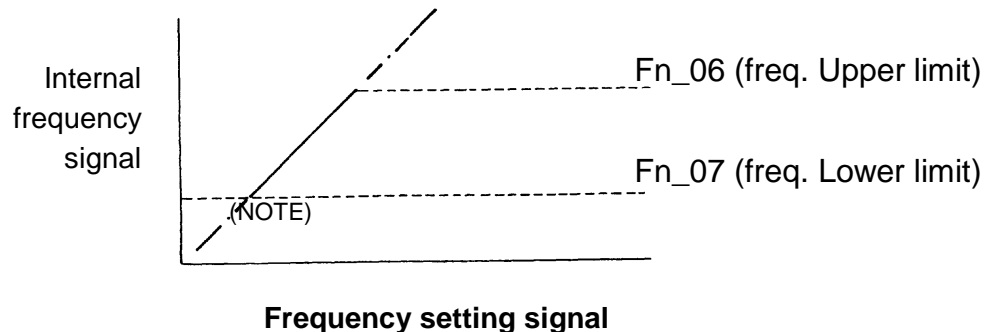

**Note:**

**If  $Fn_{07} = 0$  Hz, and the frequency instruction is equal to 0Hz, the inverter will stop at 0 speed.**

**If  $Fn_{07} > 0$  Hz, and the frequency instruction  $\leq Fn_{07}$ , the inverter will output according to  $Fn_{07}$  setting.**

**Fn\_08 : sp1 frequency = 1 up to 120Hz or 200Hz<sup>(\*)</sup>**

**Fn\_09 : jog frequency = 1 up to 10Hz or 200Hz<sup>(\*)</sup>**

(\*)Only for with CPU version from 1.9 (check function F\_29)

1. When  $Fn_{19}$  or  $Fn_{20} = 2$  and multifunction input terminal is ON, the inverter operate at sp1 frequency ( $Fn_{08}$ )
2. When  $Fn_{19}$  or  $Fn_{20} = 1$  and multifunction input terminal is ON, the inverter operate at jog frequency ( $Fn_{09}$ )
3. The priority of reading frequency setting is Jog > Sp1 > Keypad setting or external frequency signal

## **Fn\_10 : Operation Control**

**= 0 : Keypad**

**= 1 : External terminal TM2**

### **Note:**

*When Fn\_10=1 (external operation control), emergency stop on the keypad is enabled.  
When Fn\_10=1, please refer to the descriptions of F\_23/24, in order to avoid the damage to the human and the machine.*

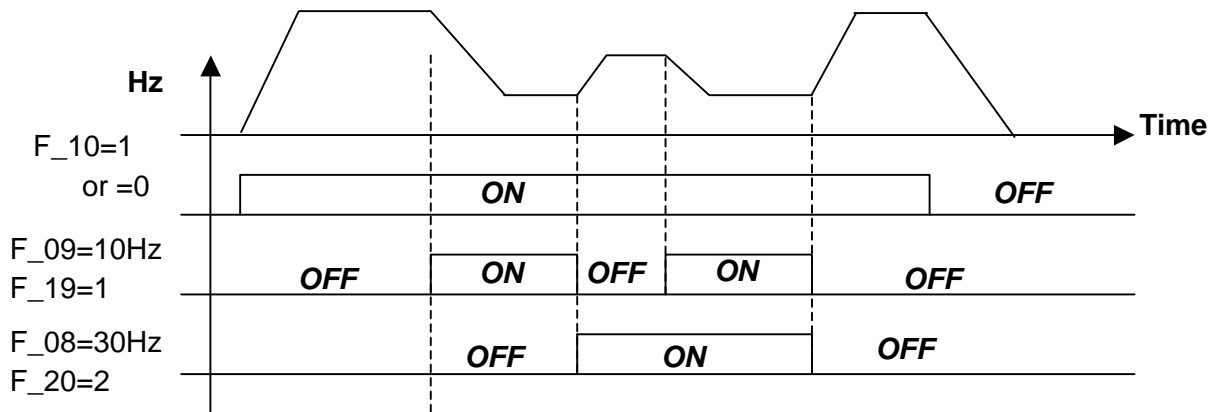

## **Fn\_11 : Frequency control**

**= 0 : Frequency instruction is setup by keypad**

**= 1 : Frequency instruction is setup by VR or analog signal on TM2 ( 0 up to 10V / 0-20mA )**

**= 2 : Frequency instruction is setup by VR or analog signal on TM2 ( 4-20mA )**

### **Note 1:**

*When Jog frequency or Sp1 frequency is switched on, the frequency is setup by Sp1 speed, the ▲▼ buttons on the keypad is disabled. Original setting will be restored after Sp1 connection is OFF.*

### **Note 2:**

*During the contact closure of the jog function, the keypad control remains in a sleep state until the jog contact connection is re-opened.*

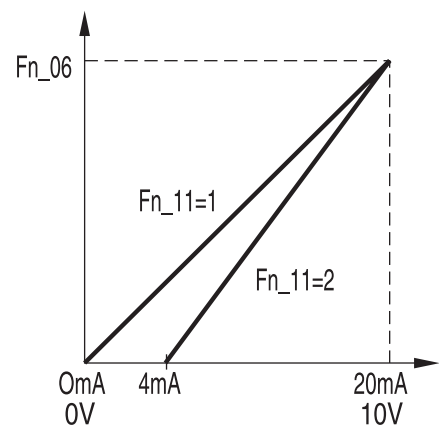

## Fn\_12 : carrier frequency = 1 up to 5 or up to 10<sup>(\*)</sup>

(\*) Only for drives with CPU version from 1.9 (check function F\_29)

F_12	Carrier frequency	F_12	Carrier frequency	F_12	Carrier frequency
1	4 kHz	5	8 kHz	9	15 kHz <sup>(1)</sup>
2	5 kHz	6	10 kHz <sup>(1)</sup>	10	16 kHz <sup>(1)</sup>
3	6 kHz	7	12 kHz <sup>(1)</sup>		
4	7.2 kHz	8	14.4 kHz <sup>(1)</sup>		

(1) If F\_12 = 7 up to 10, the inverter must operate with low load.

Although an IGBT TYPE inverter can provide a low audible noise level during its operation, it is possible that the switching of the high carrier frequency may interfere with external electronic components (or other controllers) or even cause vibration in the motor. Adjusting the carrier frequency can usually correct this problem.

## Fn\_13: Torque compensation gain = 0 up to 10 %

To enhance Inverter output torque patterns according to the B, C voltage points on the V/F pattern (refer to F\_05 description) and the (F\_13) for this feature.

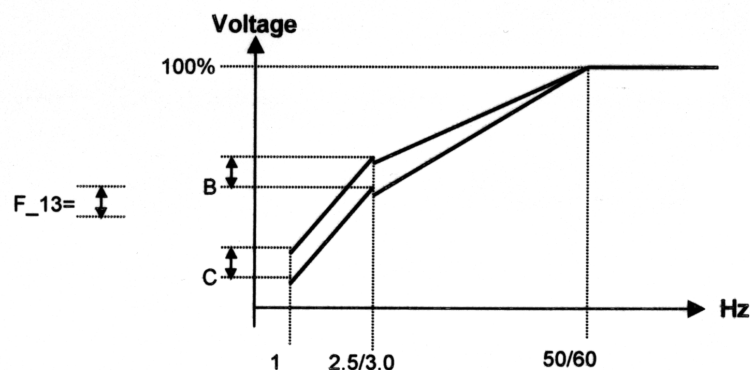

**Note :** When Fn\_13 = 0, the torque boost function is disabled.

**Fn\_14: Stopping method = 0 : decelerate stop  
1 : free run stop**

**Fn\_15: DC braking time = 0 up to 25.5 sec**

**Fn\_16: DC braking starting frequency = 1 up to 10Hz**

**Fn\_17: DC braking level = 0 up to 20%**

**If Fn\_14 = 0**

When the inverter receive the stop instruction, it decelerate to the frequency setup by Fn\_16 and then output voltage level setup in the Fn\_17; after the time duration setup in Fn\_15, the inverter turn into complete stop.

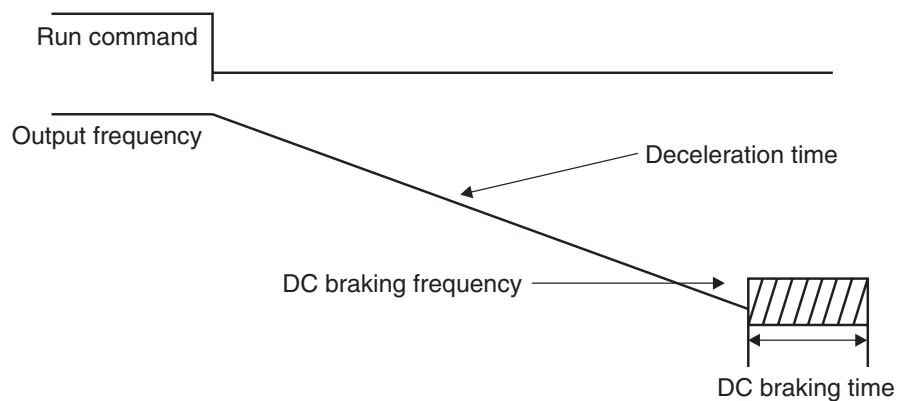

**If Fn\_14 = 1**

The inverter stop output immediately after receiving stop instruction. The motor get into free running state to completely stop.

**Fn\_18: Motor rated current = 50 up to 100 % or 0 up to 200% (\*)**

(\*) Only for drives with CPU version from 1.9 (check fnction F\_29)

**1. Function of the electronic thermal protecting motor**

- (1) Motor rated current = Inverter rated current x Fn\_18  
Fn\_18 = Motor rated current / inverter rated current
- (2) When the load is within 100% of the motor rated current, the operation continues. When the load reaches 150% of the motor rated current the operation may continues for only 1 minute. (refer to curve (1) in figures 3)
- (3) After protecting the motor with the electronic thermal switch activated, the inverter is cut off immediately. The OLI light will flash. To resume operation, push the RESET button or activate an external reset connection wired to terminal 2.
- (4) When the motor is operating at low speeds, the heat dissipation efficiency is lower. The electronic thermal activation level is also reduced. (to change from curve (1) to curve (2) in Figure 3. Choose the appropriate Fn\_05 setting according to the applied motor to reach the desired performance.

## 2. Function of the electronic thermal protecting inverter

- (1) When the load is within 103% of the inverters rated current, the operation continues. When the load reaches 150% of rated current of the inverter, the operation will continue for 1 minute. ( Refer to curve (1) of figure 3)
- (2) After the activation of the electronic thermal switch, the inverter is shut off immediately. The OL2 light will flash. To resume the operation, push RESET button or activate an external reset contact on terminal 2.

Fn\_05 = 1,2,3  
50 Hz standard motor

Fn\_05 = 4,5,6  
60 Hz standard motor

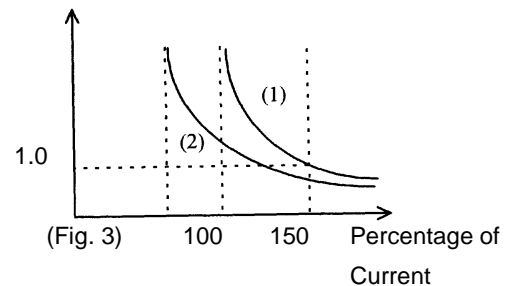
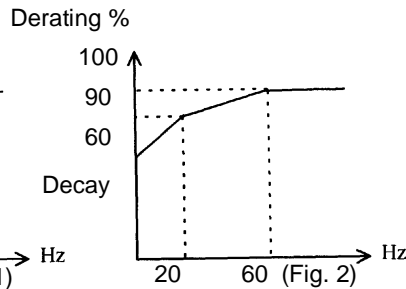
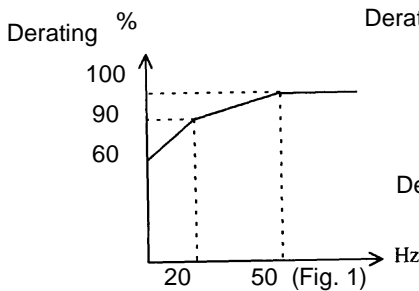

**Fn\_19: Multifunction input terminal 1 function = 1 up to 5 or 6<sup>(\*)</sup>**

**Fn\_20: Multifunction input terminal 2 function = 1 up to 5 or 6<sup>(\*)</sup>**

(\*) Only for drives with CPU version from 1.9 (check function F\_29)

1. Fn\_19, Fn\_20 = 1 : JOG (refer to F\_09)
2. Fn\_19, Fn\_20 = 2 or 6 multispeed control

**Multi-speed control (only for drives with CPU version from 1.9)**

**F\_19 = 2 and F\_20 = 6**

TM2 SP1 Terminal	TM2 RESET Terminal	Output frequency
ON	OFF	(F_08)
OFF	ON	(F_26)
ON	ON	(F_27)

**F\_19 = 6 and F\_20 = 2**

TM2 SP1 Terminal	TM2 RESET Terminal	Output frequency
ON	OFF	(F_26)
OFF	ON	(F_08)
ON	ON	SP3 (F_27)

### 3. Fn\_19, Fn\_20 =3: External emergency stop signal

When the external emergency stop signal is activated, the inverter proceeds to decelerate and stop, (ignoring the setting of Fn\_14). The inverters E.S. light will flash after stopping. After the emergency stop signal is deactivated, turn the RUN switch OFF and then ON again to cycle it. (Fn\_10 =1) Or, push the RUN key (Fn\_10=0). The inverter will then resume operation and restart. If the emergency stop signal is removed before the inverter stops, the inverter will still execute the emergency stop.

### 4. Fn\_19, Fn\_20 =4: External Base Block (immediate shut off)

When the external base block signal is activated, the inverter output will be immediately shut off (ignoring setting in Fn\_14) and flash b.b. After the base block signal deactivated, turn the RUN switch OFF and then ON again (Fn\_10 = 1) or push the RUN key (Fn\_10=0), the inverter will restart from the starting frequency.

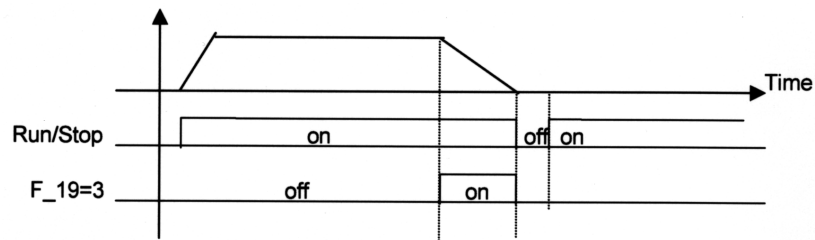

### 5. Fn\_19, Fn\_20 = 5: Reset when inverter fault.

## Fn\_21: Multi-function output terminal = 1 up to 3

1. Fn\_21 = 1: Run mode signal
2. Fn\_22 = 2: Frequency agreed signal
3. Fn\_21 = 3: Fault signal

Terminal 1 and 2 of TM2 are activated at CPF, OL1, OL2, OCS, OCA, OCC, Ocd , Ocb , OVC , LVC , OHC.

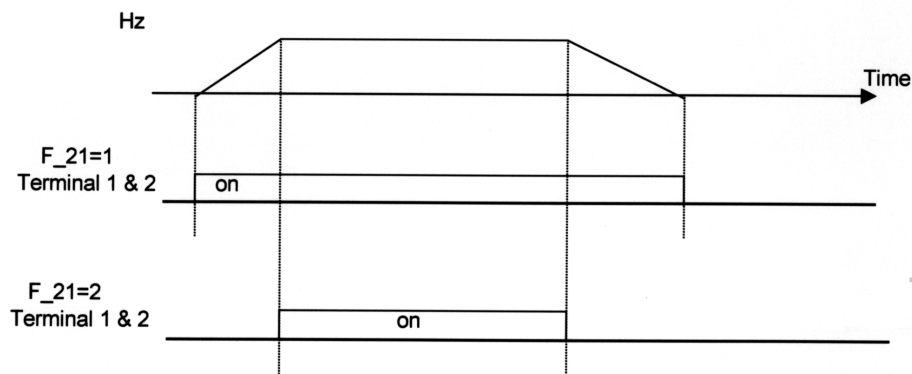

**Fn\_22:Reverse instruction = 0 : REV command enabled**  
**= 1 : REV command disabled**

**Note:**

*When Fn\_04 is set to 1 (reverse), Fn\_22 can not be set to 1, indication displays “LOC”.  
Fn\_04 must be change to 0 before setting Fn\_22 to 1.*

**Fn\_23: Restart after momentary power loss**  
**= 0 : restart enabled**  
**= 1 : restart disabled**

1. When the AC power supply is temporary below low voltage protection levels because of power company issues or encountering large current loading in the same power supply system, the inverter will stop its output immediately. If the power source resumes within 2 seconds, the inverter can restart by using its speed search program.
2. When F\_23=0:
  - (1) If the momentary power loss is less than 2 seconds, the inverter resume operation automatically via speed search at 0.5 seconds after power up. The number of auto-restart times is not limited by F\_24.
  - (2) If the momentary power loss is long, the operation of the inverter is based on the setup of F\_10 and the condition of external switch.
  - (3) If the time of momentary loss is between the above two, whether the inverter will auto-restart depends on F\_24:
    - F\_24=0: auto-restart disabled.
    - F\_24=1~5: auto-restart enabled 1~5 times.
3. When F\_23=1,
  - (1) Power up after momentary power loss, the inverter will not start. Even under F\_24>0.
  - (2) If the momentary power loss is long, the inverter must be restart manually. The operation of the inverter is based on the setup of F\_10 and the condition of external switch.
4. When restart the inverter, the operation of the inverter is based on the setup of F\_10 and the condition of external switches (FWD/REV button).
  - (1) When F\_10=0, the inverter will not start after restart.
  - (2) When F\_10=1 and the external switch (FWD/REV button) is OFF, the inverter will not start after restart.
  - (3) When F\_10=1 and the external switch (FWD/REV button) is ON, the inverter will start automatically after restart. Attention: Base on safety reason, please turn off the external switch (FWD/REV button) after power loss to avoid possible damage to the machine and the human body after sudden regeneration of power.

## **Fn\_24: Number of Auto-restart times = 0 up to 5**

1. When Fn\_24 = 0, the inverter will not try to restart.  
(Except for momentary power loss, please refer to F\_23 for details)
2. When Fn\_24 > 0, the inverter will resume operation via SPEED SEARCH at approximately 0.5 second after a function trip. After that, the inverter will accelerate or decelerate to current frequency setting.  
(Except for momentary power loss, please refer to F\_23 for details)
3. When the inverter is set to deceleration or DC breaking, the transient restart procedure is not performed.
4. When either of following situation happen, the transient restart count will be reset:
  - (1) No additional malfunction (in operation or stop) occurs within 10 minutes.
  - (2) Press RESET button or external terminal RESET is ON.

## **Fn\_25 : Factory settings function**

**= 010 : Constants initialisation to 50Hz system**

**= 020 : Constants initialisation to 60Hz system**

1. When Fn\_25 is set to 010, all parameters are restored to factory settings. The settings of Fn\_05 =1 and Fn\_06 = 50. Fn\_25 is restored back to 000 after the reset process complete (50Hz operation).
2. When Fn\_25 is set to 020, all parameters are restored to factory settings. The settings of Fn\_05 =4 and Fn\_06 = 60. Fn\_25 is restored back to 000 after the reset process complete (60Hz operation).

## **Fn\_26: SP2 (1 up to 200Hz), multi-speed 2**

**(Refer to Fn\_19, Fn\_20)**

## **Fn\_27: SP3 (1 up to 200Hz), multi-speed 3**

**(Refer to Fn\_19, Fn\_20)**

## **F\_28: Direct start**

**= 0 : Direct start enable when remote Run command on**

**= 1 : Direct start disable when remote Run command  
on drives with CPU version from 2.1  
(check function F\_29)**

When F\_28 = 1 and control mode is remote control (F\_10 = 1), the inverter can not start if RUN switch is ON when power is engaged, must be turned the RUN switch OFF and turned ON again, then inverter can start.

## **Fn\_29: software (program) version**

## **Fn\_30: Fault trace**

1. Fault trace : indicate the sequence of the occurrence of malfunctions by the location of decimal point. **x.xx** indicate a recently happened malfunction. **xx.x** indicate the last malfunction that happened. **xxx.** indicated the earliest malfunction in the record.
2. After entering the Fn\_30 function, the **x.xx** record will be displayed first. After that, press ▲ button can read out **xx.x** **xxx.** **x.xx** ,, , consecutively.
3. After entering Fn\_30 function, if the RESET button is pressed, all three malfunction record will be cleared. Indication display **-.--**, **--.-**, and **---.**
4. When the content of malfunction memory indicate O.CC, indicate the latest malfunction code is OC-C and so on.

### 3.4. Malfunction indication and countermeasure

#### 3.4.1. Manual reset inoperative faults

INDICATION	CONTENT	POSSIBLE CAUSE	COUNTERMEASURE
<b>CPF</b>	Program error	Outside noise interference	Place a RC surge absorber in parallel with the noise generating magnetic contact
<b>EPR</b>	EEPROM error	EEPROM defective	Replace EEPROM
<b>OV</b>	Voltage too high while not operating	1. Power source voltage too high. 2. Detection circuitry defective	1. Examining the power supply 2. Return the inverter for repair
<b>LV</b>	Voltage too low while not operating	1. Power source voltage too low. 2. Detection circuitry defective.	1. Examining the power supply 2. Return the inverter for repair
<b>OH</b>	Inverter over heat while not operating	1. Detection circuit defective. 2. Environment over-heat or poor ventilation	1. Return the inverter for repair 2. Improve ventilation

#### 3.4.2. Manual reset operative faults (Auto-Reset inoperative)

INDICATION	CONTENT	POSSIBLE CAUSE	COUNTERMEASURE
<b>OC</b>	Over-current at stop condition	Detection circuit malfunction	Return the inverter for repair
<b>OL1</b>	Motor over-load	1. Loading too large 2. Improper V/F model setting 3. Improper Fn_18 setting	1. Increase capacity of motor 2. Adjust to use a proper V/F curve setting 3. Adjust Fn_18 according to instruction
<b>OL2</b>	Inverter over-load	1. Loading too large 2. Improper V/F model setting	1. Increase capacity of inverter 2. Adjust to use a proper V/F curve setting

### 3.4.3. Manual Reset and Auto-Reset Operative faults

INDICATION	CONTENT	POSSIBLE CAUSE	COUNTERMEASURE
<b>OCS</b>	Transient over-current starting machine	<ol style="list-style-type: none"> <li>1. Motor coil short-circuit with external casing</li> <li>2. Motor connection wire short-circuit with grounding</li> <li>3. Transistor module damaged</li> </ol>	<ol style="list-style-type: none"> <li>1. Examining motor</li> <li>2. Examining wiring</li> <li>3. Replace transistor module</li> </ol>
<b>OCA</b>	Over-current at acceleration	<ol style="list-style-type: none"> <li>1. Acceleration time setting too short</li> <li>2. Improper V/F feature selection</li> <li>3. Applied motor capacity exceeds inverter capacity</li> </ol>	<ol style="list-style-type: none"> <li>1. Adjust acceleration time to longer setting</li> <li>2. Adjust to a proper V/F curve</li> <li>3. Replace and install another inverter with appropriate capacity</li> </ol>
<b>OCC</b>	Over-current at steady speed	<ol style="list-style-type: none"> <li>1. Transient alteration of the loading</li> <li>2. Transient alteration of the power supply</li> </ol>	<ol style="list-style-type: none"> <li>1. Examining the loading configuration</li> <li>2. Install inductor on the power supply input side</li> </ol>
<b>OCd</b>	Over-current at deceleration	Deceleration setting too short	Adjust to use a longer acceleration time
<b>OCb</b>	Over-current at breaking	DC Breaking frequency, breaking voltage, or breaking time setting too long	Adjust to reduce settings of Fn_15, Fn_16, or Fn_17
<b>OVC</b>	Over-voltage at operation/deceleration	<ol style="list-style-type: none"> <li>1. Deceleration time setting too short or inertial loading too large</li> <li>2. Power supply voltage variation too large</li> </ol>	<ol style="list-style-type: none"> <li>1. Adjust to use a longer deceleration time</li> <li>2. Install a inductor on the power supply input side</li> <li>3. Increase the capacity of inverter</li> </ol>
<b>LVC</b>	Insufficient voltage level at operation	<ol style="list-style-type: none"> <li>1. Power supply voltage too low</li> <li>2. Power supply voltage variation too large</li> </ol>	<ol style="list-style-type: none"> <li>1. Improve power source quality</li> <li>2. Adjust to use a longer acceleration time</li> <li>3. Increase capacity of inverter</li> <li>4. Install a reactor on the power supply input side</li> </ol>
<b>OHC</b>	Heat-sink over heated at operation	<ol style="list-style-type: none"> <li>1. Loading too heavy</li> <li>2. Ambient temperature too high or poor ventilation</li> </ol>	<ol style="list-style-type: none"> <li>1. Examining the loading</li> <li>2. Increase capacity of inverter</li> <li>3. Improve ventilation</li> </ol>

### 3.4.4. Other indications

INDICATION	CONTENT	DESCRIPTION
<b>SP0</b>	Zero Speed Stopping	When Fn_11 = 0, Fn_7= 0 and frequency setting < 1 Hz When Fn_11 = 1, Fn_7<(Fn_6/100), and frequency setting <(Fn_6/100)
<b>SP2</b>	Keypad emergency stop	The inverter setup to external operation (Fn_10=1). If the STOP key in the keypad is pressed at the middle of operation, the inverter stop according the setting in Fn_14 and flash SP2 after stop. The RUN switch must be turned OFF than ON to restart the machine.
<b>E.S.</b>	External emergency stop	When the external emergency stop signal is activated through the multi-function input terminal, the inverter decelerate and stop. Inverter flash E.S. after stop. (Refer to instruction for Fn_19 for detail).
<b>b.b.</b>	External BASE BLOCK	When the external BASE BLOCK signal is activated through the multifunction terminal, the inverter stop output immediately and flash b.b. for indication. (refer to instruction for Fn_19 for detail)

### 3.4.5. Keypad Operation Error Indications

INDICATION	CONTENT	POSSIBLE CAUSE	COUNTERMEASURE
<b>LOC</b>	Motor direction locked	1. Attempt to reverse direction when Fn_22 = 1  2. Attempt to set Fn_22 to 1 when Fn_04 = 1	1. Adjust Fn_22 to 0  2. Adjust Fn_04 to 0
<b>Er1</b>	Keypad operation error	1. Press ▲ or ▼ keys when Fn_11=1 or under sp1 operation  2. Attempt to modify Fn_29  3. Attempt to modify parameter that is not allowed to be modified during operation (refer to parameter list)	1. Use ▲ or ▼ keys to adjust frequency setting only after Fn_11=0  2. Do not modify Fn_29  3. Modify in stop mode
<b>Er2</b>	Parameter setting error	1. Fn_6 ≤ Fn_7	1. Fn_6 > Fn_7

### 3.5. General Troubleshooting Method

ABNORMALITY	CHECK POINT	COUNTERMEASURE
<b>Motor inoperative</b>	Is power source voltage delivered into L1, L2 terminal (is the charging indicator illuminated)?	<ul style="list-style-type: none"> <li>1 Check if the power source switched on.</li> <li>1 Turn power source OFF and then ON again.</li> <li>1 Reconfirm the power voltage level.</li> <li>1 Check to see if the mounting screw secured.</li> </ul>
	Is there voltage output from output terminal T1, T2 and T3?	<ul style="list-style-type: none"> <li>1 Turn power source OFF and then ON again.</li> </ul>
	If the loading too heavy to block motor?	<ul style="list-style-type: none"> <li>1 Reduce load to start motor.</li> </ul>
	Is there any abnormal condition of the inverter?	<ul style="list-style-type: none"> <li>1 Refer to malfunction handling instructions to examine and correct wiring.</li> </ul>
	Is the forward or reverse instruction loaded?	
	Is the analog frequency setting loaded?	<ul style="list-style-type: none"> <li>1 Check to see if wiring for analog frequency input signal is correct?</li> </ul>
	If the operation mode setting correct?	<ul style="list-style-type: none"> <li>1 Check if the frequency input setting voltage is correct?</li> </ul>
<b>Motor operate in opposite direction</b>	Is wiring on the output terminals T1, T2 and T3 correct?	<ul style="list-style-type: none"> <li>1 Operate by digital?</li> </ul>
	Is the wiring for the forward and reverse signals correct?	<ul style="list-style-type: none"> <li>1 Wiring should be in accordance with the U, V, W terminals of motor.</li> </ul>
<b>Motor operation speed fixed</b>	Is the wiring for analog frequency input correct?	<ul style="list-style-type: none"> <li>1 Examining the wiring and correct it.</li> </ul>
	Is the operation mode setting correct?	<ul style="list-style-type: none"> <li>1 Examining the wiring and correct it.</li> </ul>
	Is the loading too heavy?	<ul style="list-style-type: none"> <li>1 Operation panel operation mode setting check.</li> </ul>
<b>Motor operation at speed too high or too low</b>	Is the specification of motor (poles, voltage) correct?	<ul style="list-style-type: none"> <li>1 Reduce loading</li> </ul>
	Is the gear ratio correct?	<ul style="list-style-type: none"> <li>1 Reconfirm motor specification.</li> </ul>
	Is the highest output frequency setting correct?	<ul style="list-style-type: none"> <li>1 Reconfirm gear ratio</li> </ul>
	Is the voltage on motor side reduced extremely?	<ul style="list-style-type: none"> <li>1 Reconfirm highest output frequency</li> </ul>
<b>Abnormal speed variation at operation</b>	Is the loading too heavy?	<ul style="list-style-type: none"> <li>1 Reduce loading variation</li> </ul>
	Is the loading variation too large?	<ul style="list-style-type: none"> <li>1 Increase inverter and motor capacity</li> </ul>
	Is the input power source steady and stable?	<ul style="list-style-type: none"> <li>1 Install AC reactor on the power supply input side</li> </ul>

# Simple VAT20 Troubleshooting Procedure

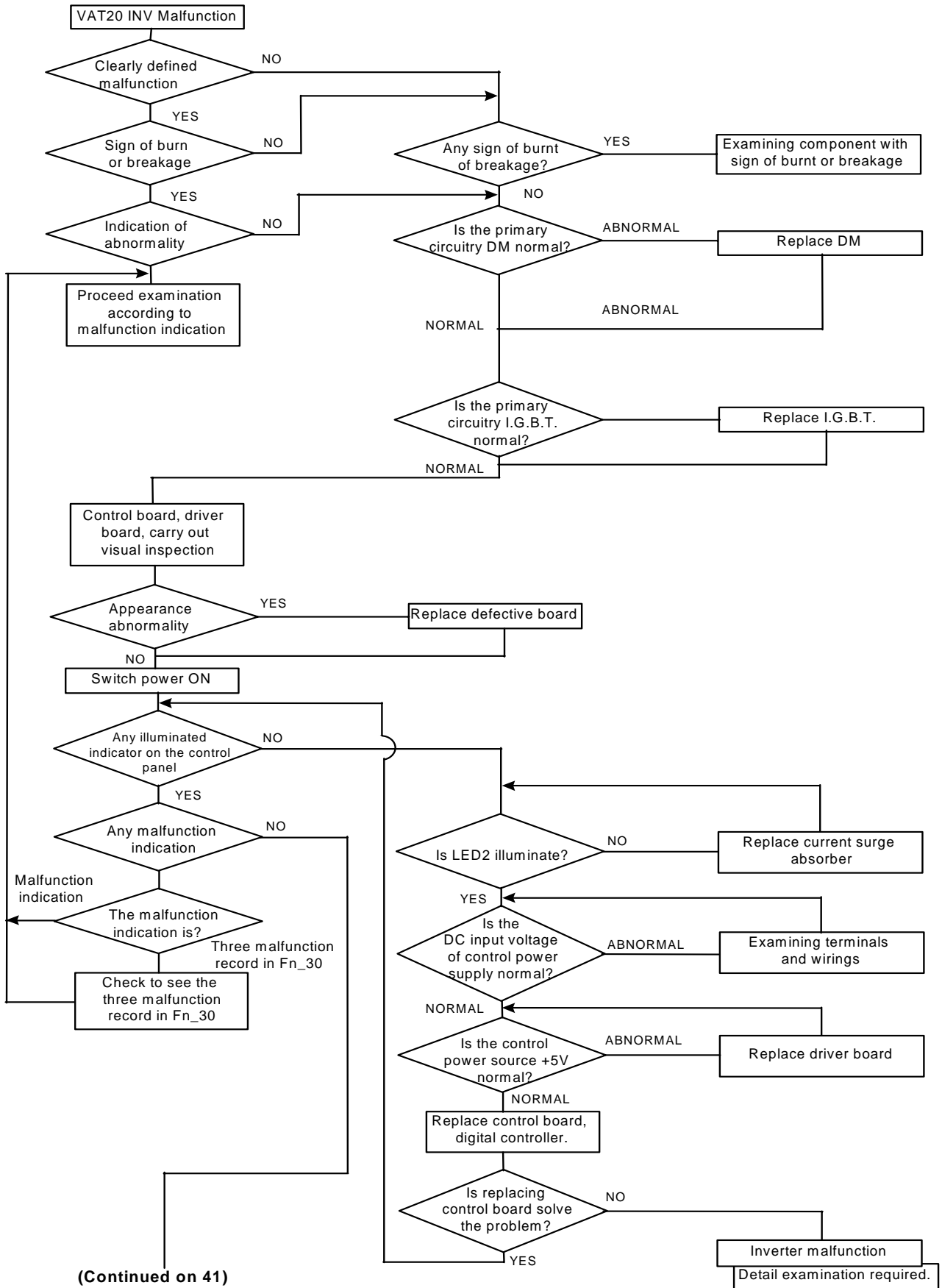

(Continued on 41)

(Continued from 40)

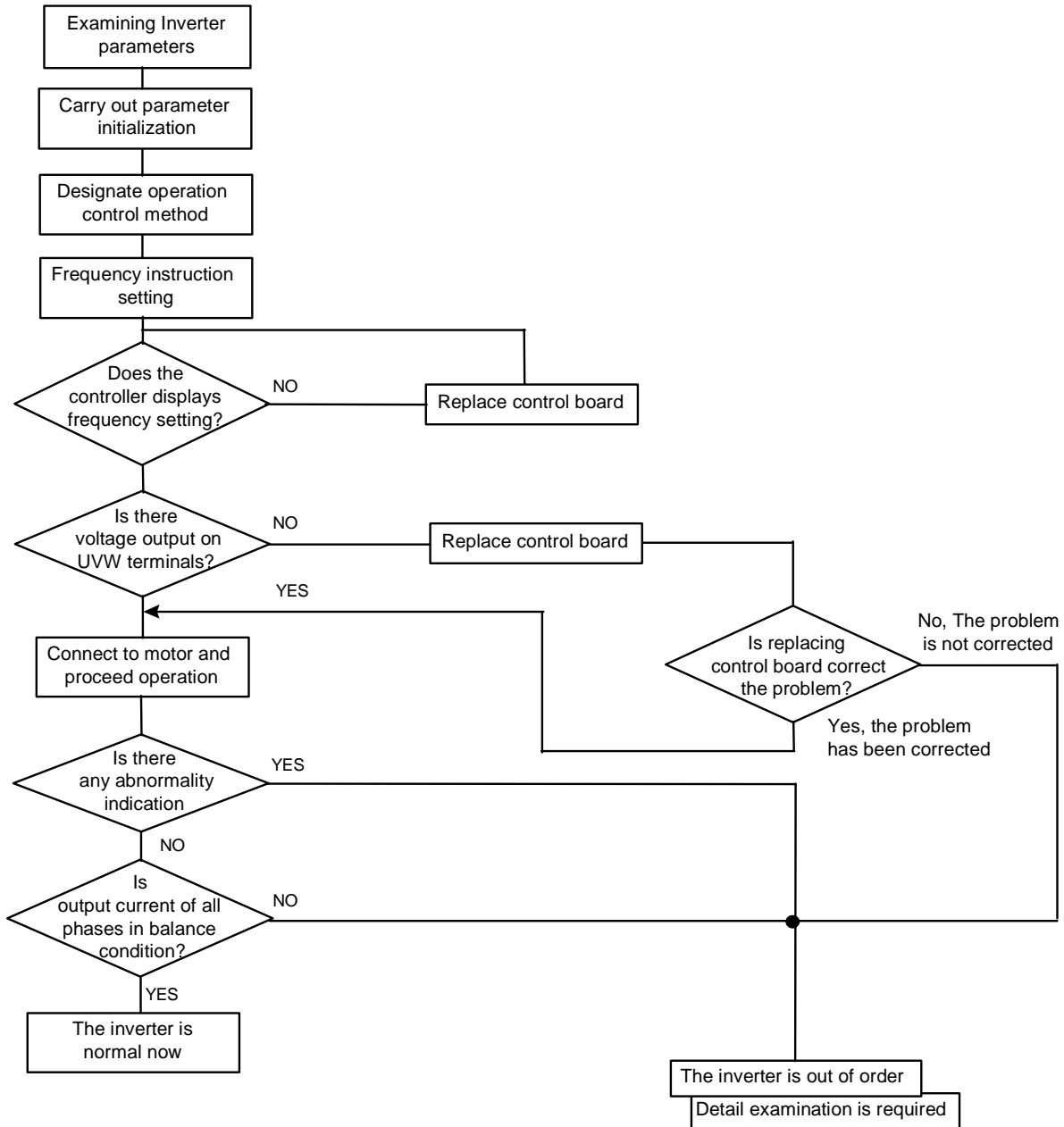

# Error handling of malfunction indication of OC.OL

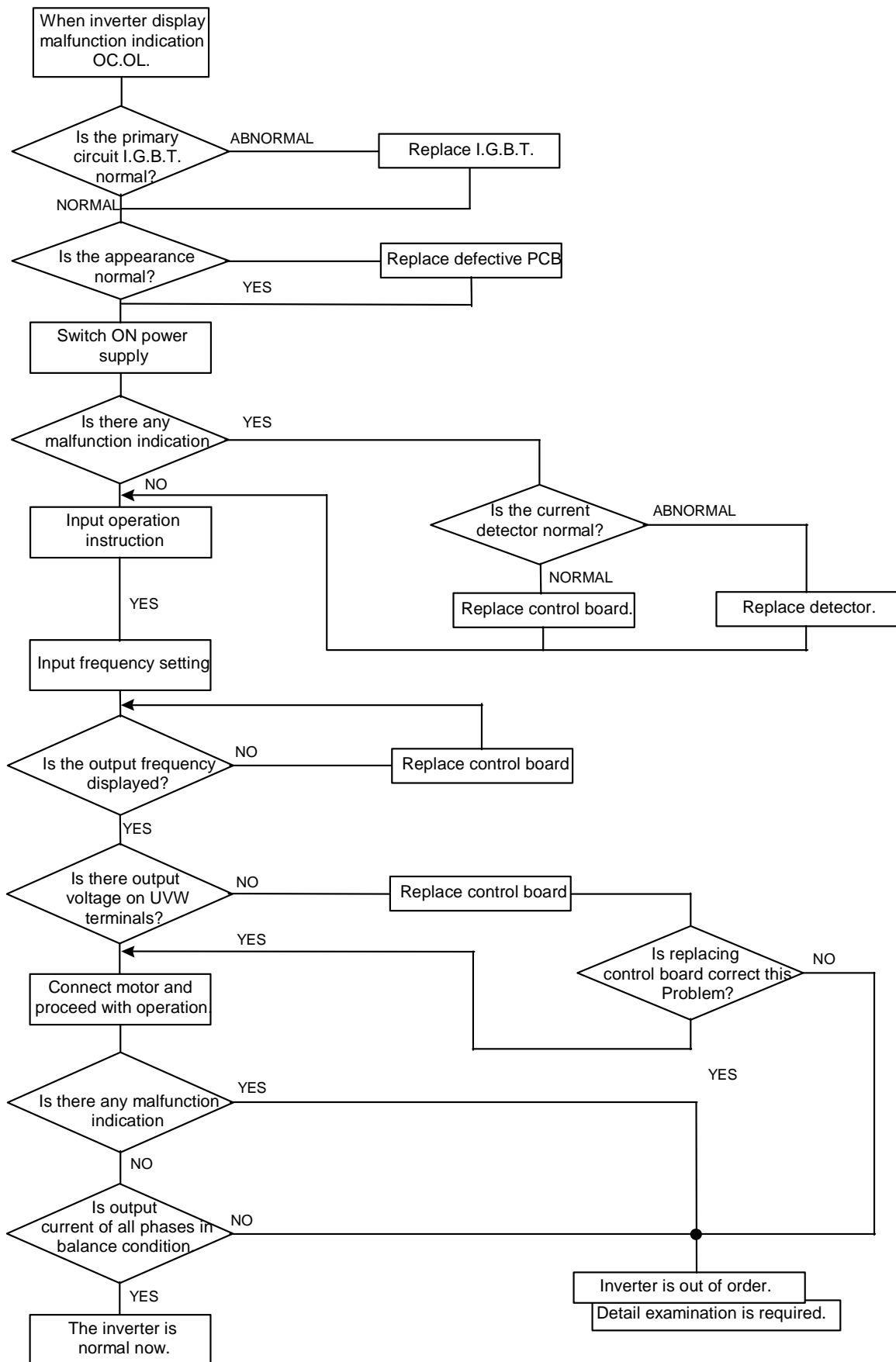

# Error handling of malfunction indication of OV.LV

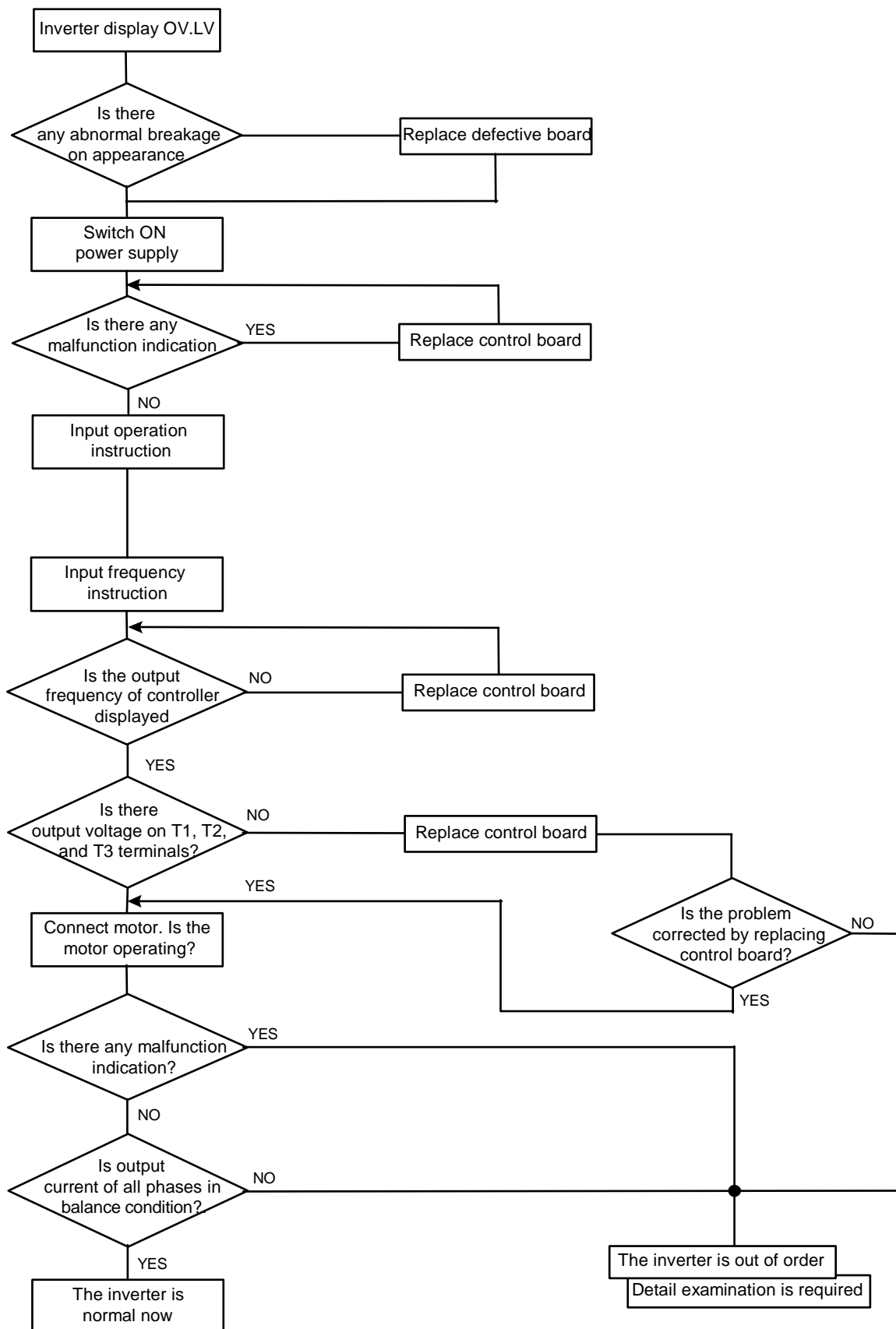

# (1) Motor inoperative

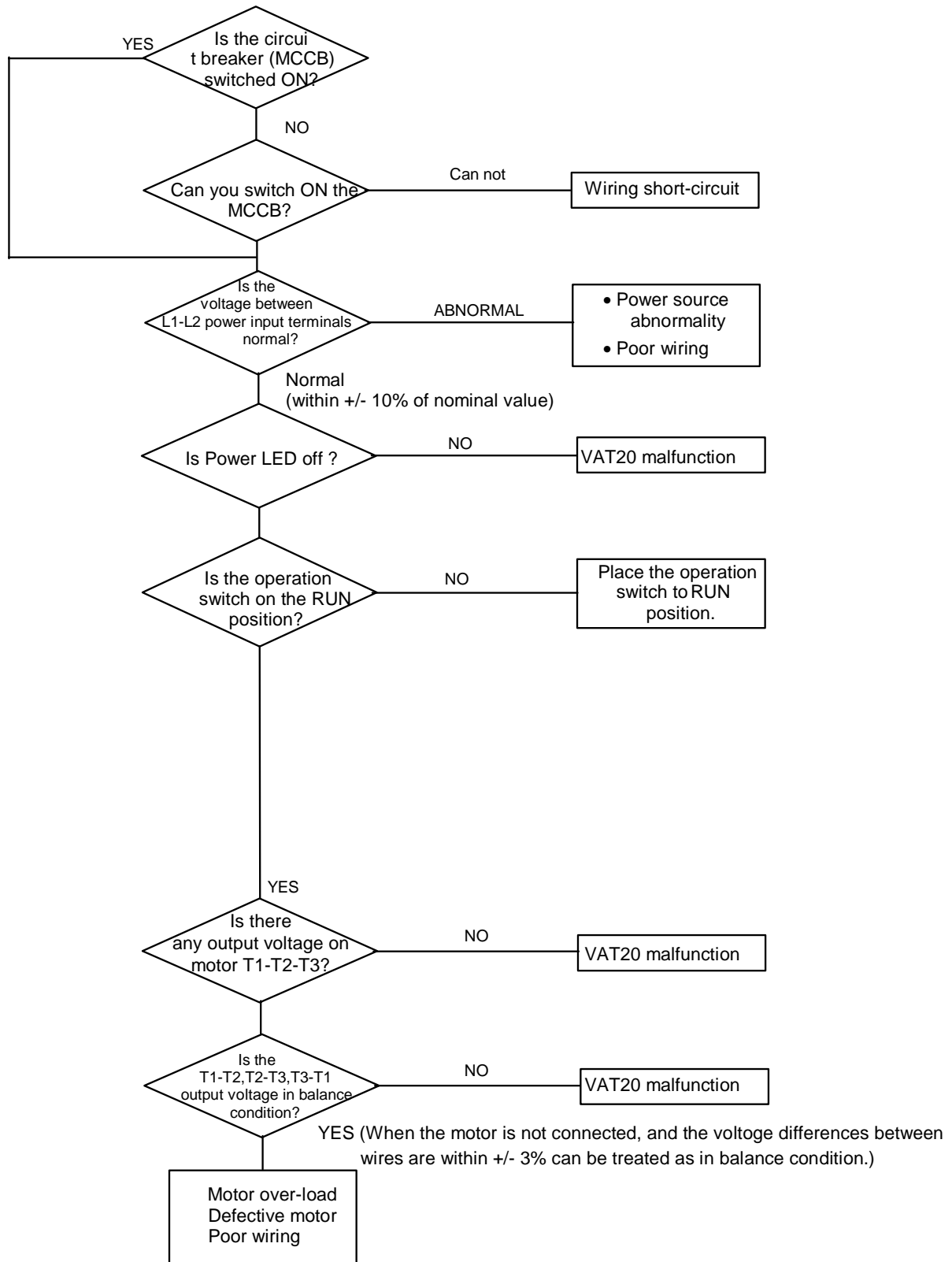

## (2) Motor over-heat

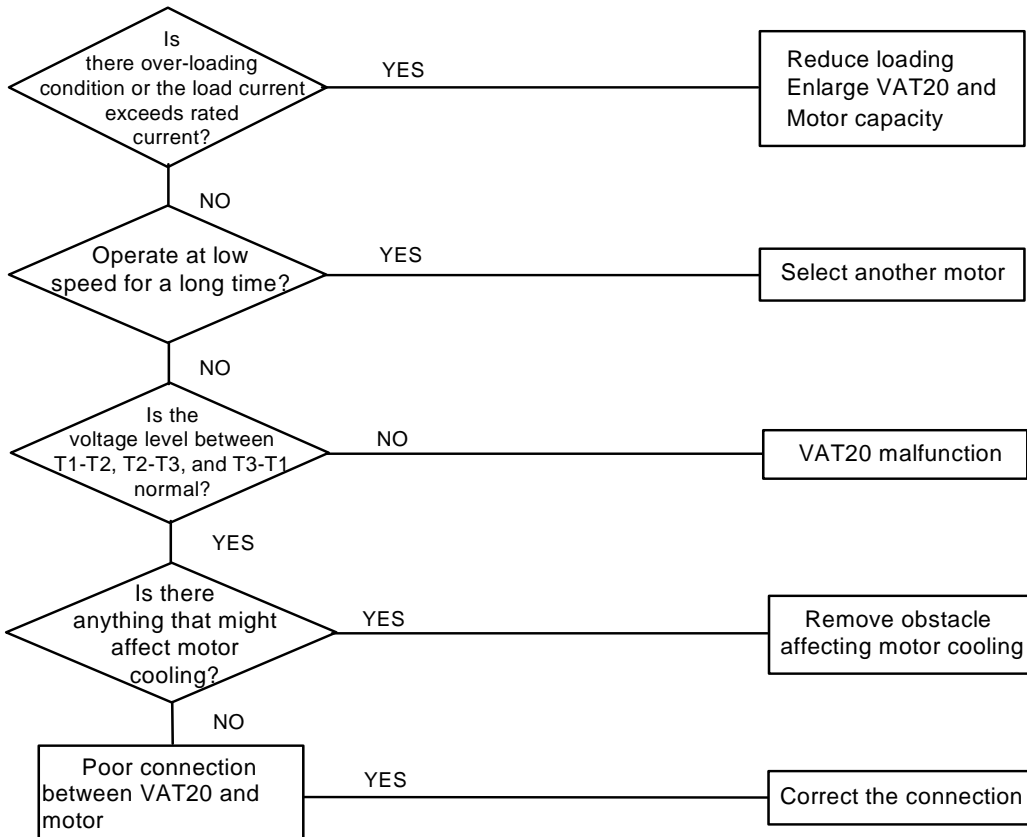

## (3) Disturbing motor operation

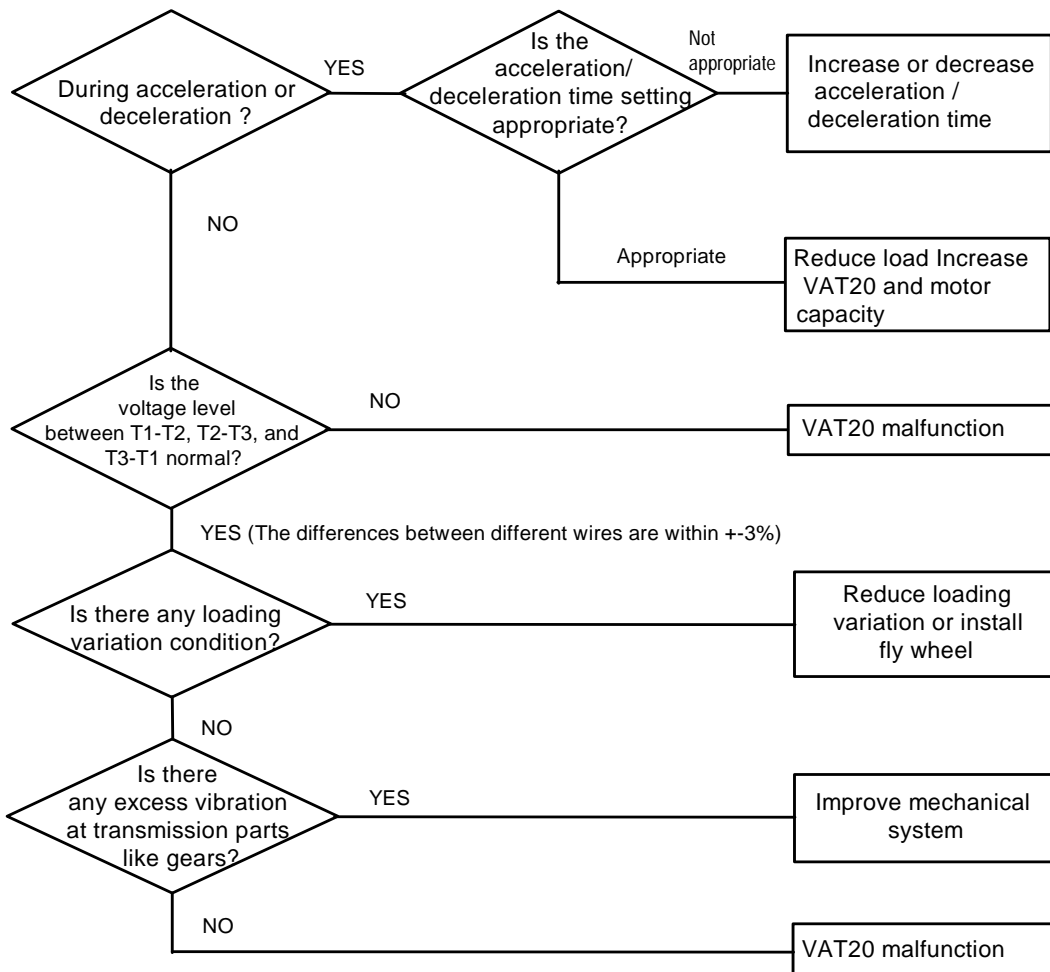

## Routine examination and periodical examination

Inverter requires routine and periodical examination and maintenance for a more stable and safer operation. Refer to following table for required examination item for a more stable and safer operation.

Carry out examination after the “ Power LED ” indicator goes off for 5 minutes to prevent the maintenance personnel injury caused by the remaining charges in the capacitor of inverter.

Maintenance item	Maintenance description	Examination period		Examination method	Criterion	Countermeasure
		Routine	1 Year			
Installation site environment	Reconfirm environment temperature and humidity	○		Refer to installation instructions and measure with thermometer and hygrometer	Temperature: -10~40 OC Humidity: under 95% without condensing	Improve installation site environment
	Check and remove any flammable material nearby	○		Visual inspection	No foreign object	
Inverter Installation and grounding	Is there any abnormal vibration on the installation site?	○		Visual and audio inspection	No foreign object	Tighten loose screw
	Is the grounding resistance within acceptable range?		○	Measure resistance by multi-meter	200V class under 100 ohm	Improve grounding
Input power source voltage	Is the voltage of the primary circuitry normal?	○		Measure voltage by multi-meter	Voltage level conforming specification	Improve input power source
Inverter external terminal mounting screw	Is the tighten parts secured?		○	Visual inspection. Use screwdriver to verify screw tightness	No abnormality	Tighten loose screw or return for repair
	Is there any sign of breakage on the terminal panel?		○			
	Is there any obvious rusty condition?		○			
Internal wiring of inverter	Is it deformed or skewed?		○	Visual inspection	No abnormality	Replace or return for repair
	Is the insulation of wire broken?		○			
Heat-sink	Is it accumulating dust or dirt?	○		Visual inspection	No abnormality	Clean up dust or dirt
PCB	Is it accumulating conductive metal or oil stain?		○	Visual inspection	No abnormality	Clean up or replace PCB
	Is there any over-heated or burnt component?		○			
Cooling fan	Is there any abnormal vibration or noise?		○	Visual and audio inspection	No abnormality	Replace cooling fan
	Is it accumulating dust or dirt?	○		Visual inspection		Clean up
Power component	Is it accumulating dust or dirt?		○	Visual inspection	No abnormality	Clean up
	Examine resistance between each terminal		○	Measure by multi-meter	No short-circuit or open-circuit on the three-phase output	Replace power component or inverter
Capacitor	Is there any sign of strange odor or leakage?	○		Visual inspection	No abnormality	Replace capacitor or inverter
	Is there any sign of swelling or bulging?	○				

# Chapter 4. Maintenance and Peripherals

## 4.1. Maintenance and Examination

Frequent examination and maintenance is not required for VAT20.

To maintain appropriate reliability for a long term of time, please proceed with following periodical examination. Remember to turn off power supply and wait till the Power LED went off before proceed. (Due to the large amount of remaining charges in the internal capacitors.)

- (1) Clean out internal dust and dirt.
- (2) Check out mounting screws on every terminal and parts. Tighten loose screws.
- (3) Dielectric strength test
  - (a) Remove all conducting wires between VAT20 and outside world. Power must be turned OFF.
  - (b) The dielectric strength test inside VAT20 should be carried out only for VAT20 major circuitry. Use DC 500V: high resistance meter. Measured resistance should be higher than 100M ohm.

**CAUTION: Do not perform dielectric strength test to the control circuit.**

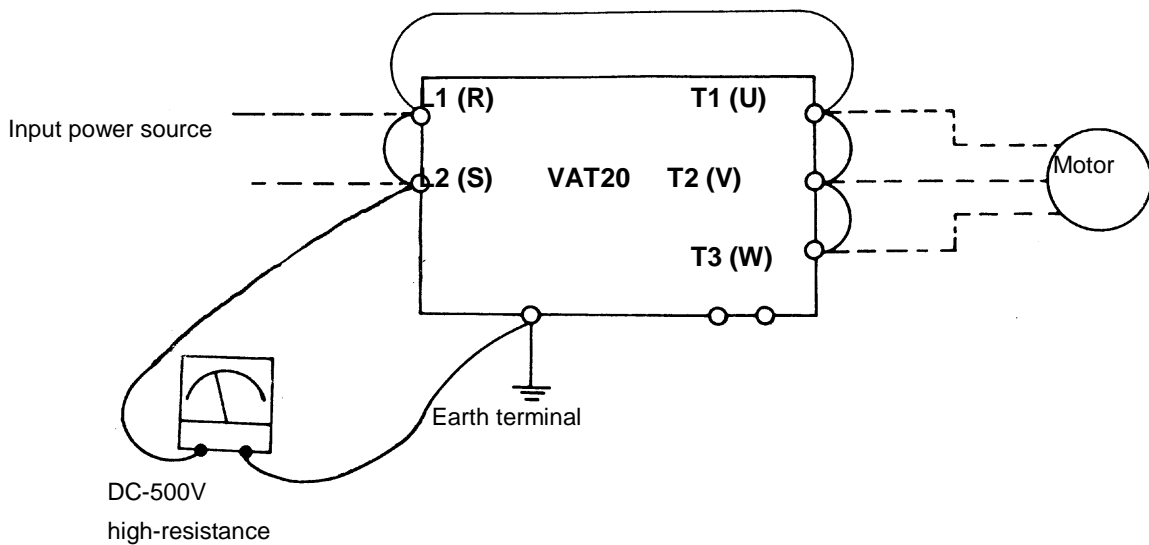

**Connection for dielectric strength test**

## 4.2. Voltage Current Measurement

The voltage and current measurement on the primary and secondary side may be different for the reason of the instrumentation and the high frequency wave. Refer to following diagram for measurement:

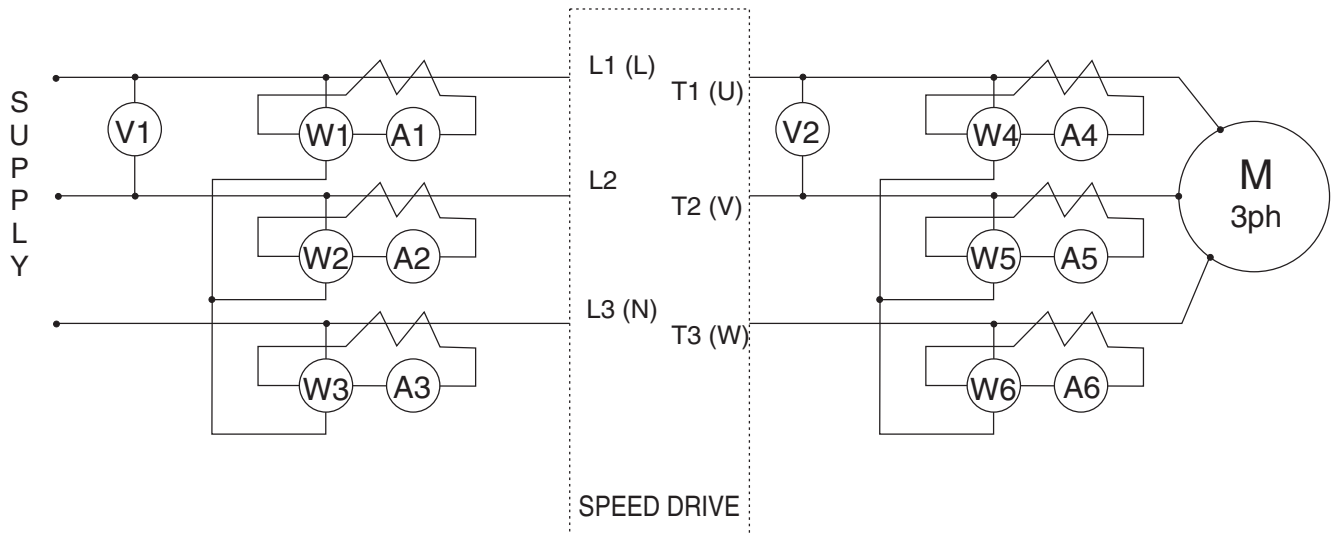

Ⓟ V1 Moving iron type Voltmeter ( Ⓟ )

Ⓡ V2 Rectifier type Voltmeter ( Ⓡ )

Ⓜ W1 to Ⓜ W6 Electrodynamicometer type power meter Ⓜ

Ⓟ A1 to Ⓟ A6 Moving iron type Ammeter ( Ⓟ )

### 4.3. Input AC Reactor Specification<sup>(1)</sup>

VAT20 Model	AC Reactor <sup>(2)</sup>	AC Reactor <sup>(3)</sup>	VAT20 Model	AC Reactor <sup>(2)</sup>	AC Reactor <sup>(3)</sup>
U20N0K2	ACR3A7H0	37G00204	U20X0K7	ACR3A8H1	37G00201
U20N0K4	ACR8A2H5	37G00204	U20X1K5	ACR4A5H1	37G00402
U20N0K7	ACR12A2H5	37G00401	U20X2K2	ACR6A3H4	37G00402
1ph, U20N1K5 3ph, U20N1K5	ACR18A1H3 ACR6A2H5	37G00801			
1ph, U20N2K2 3ph, U20N2K2	ACR22A0H84 ACR9A1H3	37G01201			

### 4.4. EMI Filter (class B) Specification<sup>(1)</sup>

Model	Dimensions (mm)	Current(A)	VAT20 model
U20AF0K7	156X76X25	10A	U20N0K2 U20N0K4 U20N0K7
U20AF2K2	170x221x38		U20N1K5 U20N2K2
U20AF2K2X	171x221x38		U20X0K7 U20X1K5 U20X2K2

### 4.5. DIN RAIL Specification<sup>(1)</sup>

Model	Dimensions	VAT20 model
U20AR0K7	130x72x7.5	U20N0K2, U20N0K4, U20N0K7, U20N1K5, U20N2K2 U20X0K7, U20X1K5, U20X2K2

### 4.6. Dynamic Braking resistor Specification<sup>(1)</sup>

VAT20 Model	Motor kW / HP	Braking resistor	Braking resistor <sup>(3)</sup>
U20N1K5	1.5 / 2	TLR100P200	DB2F22C
U20N2K2	2.2 / 3	TLR75P200	DB2F22C
U20X0K7	0.75 / 1	TLR750P200	DB0F754C
U20X1K5	1.5 / 2	TLR400P200	DB2F24C
U20X2K2	2.2 / 3	TLR250P200	DB2F24C

(1) All above are optional devices not included with the drive and sold separately.

(2) Optional device part numbers available in the European market

(3) Optional device part numbers available in the American market