



[efesotomasyon.com](http://efesotomasyon.com)

---

# *GE Fanuc Automation*

---

*Programmable Control Products*

## *Series 90™ -30 PLC Installation and Hardware Manual*

GFK0356P

October 1999

## *Warnings, Cautions, and Notes as Used in this Publication*

### **Warning**

**Warning notices are used in this publication to emphasize that hazardous voltages, currents, temperatures, or other conditions that could cause personal injury exist in this equipment or may be associated with its use.**

**In situations where inattention could cause either personal injury or damage to equipment, a Warning notice is used.**

### **Caution**

**Caution notices are used where equipment might be damaged if care is not taken.**

### **Note**

Notes merely call attention to information that is especially significant to understanding and operating the equipment.

This document is based on information available at the time of its publication. While efforts have been made to be accurate, the information contained herein does not purport to cover all details or variations in hardware or software, nor to provide for every possible contingency in connection with installation, operation, or maintenance. Features may be described herein which are not present in all hardware and software systems. GE Fanuc Automation assumes no obligation of notice to holders of this document with respect to changes subsequently made.

GE Fanuc Automation makes no representation or warranty, expressed, implied, or statutory with respect to, and assumes no responsibility for the accuracy, completeness, sufficiency, or usefulness of the information contained herein. No warranties of merchantability or fitness for purpose shall apply.

The following are trademarks of GE Fanuc Automation North America, Inc.

|                   |             |             |              |
|-------------------|-------------|-------------|--------------|
| Alarm Master      | Genius      | ProLoop     | Series Three |
| CIMPLICITY        | Helpmate    | PROMACRO    | VersaMax     |
| CIMPLICITY 90-ADS | Logicmaster | Series Five | VersaPro     |
| CIMSTAR           | Modelmaster | Series 90   | VuMaster     |
| Field Control     | Motion Mate | Series One  | Workmaster   |
| GEnet             | PowerTRAC   | SeriesSix   |              |

## RFI Standards

---

The Series 90™ -30 PLC and its associated modules have been tested and found to meet or exceed the requirements of FCC Rule, Part 15, Subpart J. The Federal Communications Commission (FCC) requires the following note to be published according to FCC guidelines.

### NOTE

This equipment generates, uses, and can radiate radio frequency energy and if not installed in accordance with this instruction manual, may cause harmful interference to radio communications. It has been tested and found to comply with the limits for a Class A digital device pursuant to Part 15 of the FCC Rules, which are designed to provide reasonable protection against harmful interference when operated in a commercial environment. Operation of this equipment in a residential area is likely to cause harmful interference, in which case the user will be required to correct the interference at his own expense.

The following note is required to be published by the Canadian Department of Communications.

### NOTE

This digital apparatus does not exceed the Class A limits for radio noise emissions from digital apparatus set out in the radio interference regulations of the Canadian Department of Communications.

The following statements are required to appear in the *Series 90™ -30 Installation Manual* and the *Series 90™ -30 I/O Specifications Manual* for Class I Div 2 Hazardous Locations.

1. **EQUIPMENT LABELED WITH REFERENCE TO CLASS I, GROUPS A, B, C, and D, DIV. 2 HAZARDOUS LOCATIONS IS SUITABLE FOR USE IN CLASS I, DIVISION 2, GROUPS A, B, C, D OR NON-HAZARDOUS LOCATIONS ONLY.**
2. **WARNING - EXPLOSION HAZARD - SUBSTITUTION OF COMPONENTS MAY IMPAIR SUITABILITY FOR CLASS I, DIVISION 2:**
3. **WARNING - EXPLOSION HAZARD - DO NOT DISCONNECT EQUIPMENT UNLESS POWER HAS BEEN SWITCHED OFF OR THE AREA IS KNOWN TO BE NON-HAZARDOUS.**
4. **ALL UNUSED SLOTS IN ALL BASEPLATES MUST BE POPULATED WITH FILLER MODULES, IC693ACC310, OR EQUIVALENT**

# *Preface*

---

This manual describes the GE Fanuc Series 90™ -30 Programmable Logic Controller (PLC). It contains a description of hardware components and provides basic hardware installation procedures. The Series 90-30 PLC is a member of the Series 90™ family of Programmable Logic Controllers from GE Fanuc.

For a list of product standards, refer to data sheet GFK-0867B or later, *GE Fanuc Approvals, Standards, General Specifications* which lists all of the standards for GE Fanuc products.

Installation instructions in this manual are provided for installations that do not require special procedures for noisy or hazardous environments. For installations that must conform to more stringent requirements (such as CE Mark), see GFK-1179, *Installation Requirements for Conformance to Standards*.

## What's New in This Manual

- This manual has been rearranged into 13 chapters, each covering a specific topic such as Installation, Baseplates, Power Supplies, CPUs, Option Modules, etc.
- Chapter 5 contains information about CPU models IC693CPU363 and IC693CPU364 and CPU firmware release 9.00 features for CPUs 350 – 364.
- Chapter 7 contains information about the IC693DVM300 Digital Valve Driver module.
- Preliminary information about Option modules IC693DSM314 and IC693PTM100/101 (Chapter 8), and Power Supply IC693PWR328 (Chapter 4) has been added.
- Chapter 6 contains information on memory backup strategy and on the backup battery, including such things as reading battery date codes and estimating battery life.
- Chapter 10 includes additional information on both new and old cables, including a cable-to-product cross-reference table.
- Chapter 12 introduces a new subject, System Design, to this manual. It describes factors to consider and specifications needed for designing a Series 90-30 system.
- Chapter 13 presents information on the subject of maintenance and troubleshooting and includes information on obtaining technical help and information via the Web site, Fax Link, and Technical Support telephone numbers.
- Appendix G discusses new port isolator IC690ACC903.
- A new section describing how to calculate Series 90-30 heat dissipation can be found in Appendix H.
- A product to publication number cross-reference has been added (Appendix I) to help you find documentation for Series 90-30 products.
- Appendix J includes information on the new Terminal Block Quick Connect (IC693ACC377) and associated cables for 32-point modules.
- Appendix K covers the subject of SNP Multidrop.
- Appendix L contains data on Ethernet Transceivers IC649AEA102 and IC649AEA103.
- Appendix M contains useful tables and formulas.

*Some of the new modules and/or other products referenced above may not be available when this manual is printed. For current availability of features and products consult your local GE Fanuc PLC distributor or GE Fanuc sales representative.*

## Content of this Manual

**Chapter 1. Overview of the Series 90-30 PLC:** This chapter provides you with an introduction to the Series 90-30 Programmable Logic Controller products and an overview of how they fit together into a system.

**Chapter 2. Installation:** Provides information such as mounting, wiring, and grounding Series 90-30 components.

**Chapter 3. Baseplates:** Baseplate types, descriptions, and specifications.

**Chapter 4. Power Supplies:** Power supply types, descriptions, and specifications.

**Chapter 5. CPUs:** CPU types, descriptions, and specifications.

**Chapter 6. Memory Backup and Backup Battery:** Discusses various memory backup strategies as well as battery issues, such as battery life estimation and date code interpretation.

**Chapter 7. Input and Output Modules:** Covers an overview of these modules. This chapter refers you to the *Series 90-30 I/O Module Specifications Manual (GFK-0898)* for details on these modules.

**Chapter 8. Option Modules:** Covers an overview of these modules. This chapter refers you to the various manuals that cover these modules in detail.

**Chapter 9. State Logic Products:** Covers an overview of these modules. This chapter refers you to the various manuals that cover these modules in detail.

**Chapter 10. Cables:** Contains a cable-to-product cross-reference table as well as data sheets for the Series 90-30 cables.

**Chapter 11. Programmer Hardware Products.** Discusses such things as WSI boards, PCIF cards, and converters and isolators.

**Chapter 12. System Design:** Factors to consider when designing a Series 90-30 PLC system. Includes specifications and layout information needed for the design process.

**Chapter 13. Maintenance:** Features of Series 90-30 hardware and software that are useful for troubleshooting. Also contains tables of spare parts and preventive maintenance suggestions, and a fuse-to-module cross-reference. Includes information on accessing GE Fanuc technical help resources such as Fax Link and our Web site.

**Appendix A. Glossary:** Contains terms relevant to the Series 90-30 PLC and to Programmable Logic Controllers in general.

**Appendix B. Commonly used Acronyms.**

**Appendix C. Serial Port and Cables:** Serial port and cable specifications.

**Appendix D. IC690ACC900 Converter:** Contains detailed information about this **obsolete** product.

**Appendix E. IC655CCM590 Isolated Repeater/Converter:** Contains detailed information about this **obsolete** product

**Appendix F. IC690ACC901 Miniconverter Kit:** Product description and specifications.

**Appendix G. IC690ACC903 Port Isolator:** Product description and specifications.

**Appendix H. Series 90-30 Heat Dissipation:** How to calculate heat dissipation for the purpose of sizing enclosures.

**Appendix I. Catalog Number to Publication Cross-Reference:** Lists applicable publications for Series 90-30 product catalog numbers.

**Appendix J. Terminal Block Quick Connect.** Describes the Terminal Block Quick Connect system, which consists of an interposing terminal block, faceplate, and cable. This assembly allows faster wiring of some discrete I/O modules.

**Appendix K. SNP Multidrop.** Explains how to connect a programming unit to multiple PLCs and/or Option modules.

**Appendix L. Ethernet Transceivers.** Data on the two transceivers sold by GE Fanuc.

**Appendix M. Tables and Formulas.** Contains information such as Fahrenheit to Celsius temperature conversion, AWG wire sizes to Metric conversion, ASCII codes, Metric to English units conversions, etc.

**Appendix N. 44A720084-001 EMI Line Filter.** Describes the optional EMI line filter that was used on some early versions of the Series 90-30 PLC to meet FCC EMI requirements for non-industrial applications.

## Related Publications:

For more information on Series 90-30 products, refer to these publications (note: a publication to product catalog number cross-reference is provided in Appendix H):

- GFK-0255 - Series 90™ PCM and Support Software User's Manual
- GFK-0256 - MegaBasic™ Programming Reference Manual
- GFK-0293 - Series 90™-30 High Speed Counter User's Manual
- GFK-0401 - Workmaster® II PLC Programming Unit Guide to Operation
- GFK-0402 - Series 90™-30 and 90-20 PLC Hand-Held Programmer User's Manual
- GFK-0412 - Genius® Communications Module User's Manual
- GFK-0466 - LogiMaster 90™ Series 90™-30/20 Micro Programming Software User's Manual
- GFK-0467 - Series 90™-30/20 Micro Programmable Controllers Reference Manual
- GFK-0487 - Series 90™ PCM Development Software (PCOP) User's Manual
- GFK-0499 - CIMPPLICITY® 90-ADS Alphanumeric Display System User's Manual
- GFK-0582 - Series 90™ PLC Serial Communications User's Manual
- GFK-0631 - Series 90™-30 IO LINK Interface User's Manual
- GFK-0641 - CIMPPLICITY® 90-ADS Alphanumeric Display System Reference Manual
- GFK-0664 - Series 90™-30 PLC Axis Positioning Module Programmer's Manual
- GFK-0685 - Series 90™ Programmable Controllers Flow Computer User's Manual
- GFK-0695 - Series 90™-30 Enhanced Genius® Communications Module User's Manual
- GFK-0726 - Series 90™-30 PLC State Logic Processor User's Guide
- GFK-0732 - Series 90™-30 PLC ECLiPS User's Manual
- GFK-0747 - Series 90™-30 PLC OnTOP User's Guide
- GFK-0750 - OnTop for Series 90™-30 (State Logic) Program User's Manual
- GFK-0781 - Motion Mate™ APM300 for Series 90™-30 PLC Follower Mode User's Manual
- GFK-0823 - Series 90™-30 I/O LINK Master Module User's Manual
- GFK-0828 - Series 90™-30 Diagnostic System User's Manual
- GFK-0840 - Motion Mate™ APM300 for Series 90™-30 PLC Standard Mode User's Manual
- GFK-0867 - GE Fanuc Product Agency Approvals, Standards, General Specifications
- GFK-0898 - Series 90™-30 PLC I/O Module Specifications
- GFK-1028 - Series 90™-30 I/O Processor Module User's Manual
- GFK-1034 - Series 90™-30 Genius® Bus Controller User's Manual
- GFK-1037 - Series 90™-30 FIP Remote I/O Scanner User's Manual
- GFK-1056 - Series 90™-30 State Logic Control System User's Manual
- GFK-1186 - TCP/IP Ethernet Communications for the Series 90™ -30 PLC Station Manager Manual
- GFK-1179 - Series 90™ PLC Installation Requirements for Conformance to Standards
- GFK-1464 - Motion Mate DSM302 for Series 90™ -30 PLCs User's Manual
- GFK-1466 - Temperature Control Module for the Series 90™ -30 PLC User's Manual
- GFK-1541 - TCP/IP Ethernet Communications for the Series 90™ PLC User's Manual

## **We Welcome Your Comments and Suggestions**

At GE Fanuc Automation, we strive to produce quality technical documentation. After you have used this manual, please take a few moments to complete and return the Reader's Comment Card located on the next page.

*Thomas W. Myrtle*  
Senior Technical Writer



|                      |  |                |
|----------------------|--|----------------|
| <b>Chapter 1</b>     | <b>Overview of the Series 90-30 PLC</b>                                  | <b>1-1</b>     |
|                      | The Basic Parts of a Series 90-30 PLC                                    | 1-1            |
|                      | Assembling a Basic Series 90-30 PLC System                               | 1-2            |
|                      | What else would be needed to make this basic system functional?          | 1-6            |
|                      | What if the application requires more than five modules?                 | 1-6            |
|                      | What if the application requires more than ten modules?                  | 1-7            |
|                      | What is the Difference Between Expansion and Remote baseplates?          | 1-8            |
|                      | What if I need to cover more than 700 feet (213 meters) ?                | 1-9            |
| <br><b>Chapter 2</b> | <br><b>Installation</b>  | <br><b>2-1</b> |
|                      | Receiving your Products – Visual Inspection                              | 2-1            |
|                      | Pre-installation Check   | 2-1            |
|                      | Warranty Claims  | 2-1            |
|                      | Working with Series 90-30 Modules  | 2-2            |
|                      | Baseplate Mounting   | 2-8            |
|                      | Mounting a Baseplate to a Panel  | 2-8            |
|                      | Mounting a Baseplate to a 19" Rack                                       | 2-8            |
|                      | Grounding Procedures   | 2-11           |
|                      | System Grounding Procedures  | 2-11           |
|                      | Series 90-30 PLC Equipment Grounding                                     | 2-12           |
|                      | Module Shield Grounding  | 2-14           |
|                      | General Wiring Guidelines  | 2-17           |
|                      | Discrete I/O Module Connection Methods                                   | 2-18           |
|                      | Connections to I/O Module Terminal Boards                                | 2-18           |
|                      | Terminal Block Quick Connect Installation for 16-Point Discrete Modules  | 2-19           |
|                      | Installation of 32-Point Discrete, 50-Pin Connector Modules              | 2-19           |
|                      | Installation of Discrete 32-Point, Dual 24-Pin Connector Modules         | 2-20           |
|                      | General Wiring Methods for Analog Modules                                | 2-21           |
|                      | Analog Input Module Wiring Methods                                       | 2-21           |
|                      | Analog Output Module Wiring  | 2-22           |
|                      | AC Power Source Connections  | 2-23           |
|                      | Special Installation Instructions for Floating Neutral (IT) Systems      | 2-25           |
|                      | Definition of Floating Neutral Systems                                   | 2-25           |
|                      | Use These Special Installation Instructions for Floating Neutral Systems | 2-26           |
|                      | DC Power Source Connections  | 2-27           |
|                      | Basic Installation Procedure   | 2-28           |

# Contents

---

|                  |  |            |
|------------------|--|------------|
| <b>Chapter 3</b> | <b>Baseplates</b> .....  | <b>3-1</b> |
|                  | Baseplate Types .....  | 3-1        |
|                  | Baseplate Terms Explained .....                                    | 3-3        |
|                  | CPU Baseplates .....   | 3-4        |
|                  | Expansion Baseplates (Figures 3-6 and 3-7) .....                   | 3-8        |
|                  | Remote Baseplates (Figures 3-8 and 3-9) .....                      | 3-10       |
|                  | Expansion Rack Connection Example .....                            | 3-16       |
|                  | Expansion and Remote Baseplates Connection Example .....           | 3-17       |
|                  | Baseplate Mounting Dimensions .....                                | 3-18       |
|                  | Load Ratings, Temperature, and Mounting Position .....             | 3-21       |
|                  | Baseplate Adapter Brackets for 19" Rack Mounting .....             | 3-22       |
| <br>             |  |            |
| <b>Chapter 4</b> | <b>Power Supplies</b> .....  | <b>4-1</b> |
|                  | Power Supply Categories .....                                      | 4-1        |
|                  | Power Supply Feature Comparison .....                              | 4-1        |
|                  | AC/DC Input Power Supplies .....                                   | 4-2        |
|                  | IC693PWR321 Standard Power Supply, 120/240 VAC or 125 VDC Input .  | 4-2        |
|                  | IC693PWR330 High Capacity Power Supply, 120/240 VAC/125 VDC Input  | 4-4        |
|                  | Field Wiring Connections for the AC/DC Input Power Supplies .....  | 4-5        |
|                  | DC Input Only Power Supplies .....                                 | 4-7        |
|                  | Calculating Input Power Requirements for IC693PWR322 .....         | 4-8        |
|                  | Calculating Input Power Requirements for IC693PWR328 .....         | 4-11       |
|                  | IC693PWR331 High Capacity Power Supply, 24 VDC Input .....         | 4-13       |
|                  | Calculating Input Power Requirements for IC693PWR331 .....         | 4-15       |
|                  | Field Wiring Connections to the DC Input-Only Power Supplies ..... | 4-16       |
|                  | Common Series 90-30 Power Supply Features .....                    | 4-17       |
|                  | Output Voltage Connections to Backplane (All Supplies) .....       | 4-18       |

|                      |  |                |
|----------------------|--|----------------|
| <b>Chapter 5</b>     | <b>CPUs</b> .....  | <b>5-1</b>     |
|                      | CPU Types for Series 90-30 PLCs .....                            | 5-1            |
|                      | Embedded CPUs .....  | 5-1            |
|                      | Modular CPUs .....   | 5-2            |
|                      | General CPU Features .....                                       | 5-3            |
|                      | Series 90-30 CPU Capacities .....                                | 5-10           |
|                      | User Memory Addresses (References) .....                         | 5-11           |
|                      | Difference Between a Memory Address and a Nickname .....         | 5-11           |
|                      | User Memory Reference Types .....                                | 5-11           |
|                      | 350 - 364 CPUs .....   | 5-13           |
|                      | Hardware Features of the 350 - 364 CPUs .....                    | 5-18           |
|                      | CPU350 and CPU360 Hardware Features .....                        | 5-18           |
|                      | CPU351, CPU352, and CPU363 Hardware Features .....               | 5-19           |
|                      | CPU364 Hardware Features .....                                   | 5-22           |
|                      | CPU Data Sheets .....  | 5-24           |
|                      | CPU313            Catalog Number IC693CPU313 .....               | 5-26           |
|                      | CPU323            Catalog Number IC693CPU323 .....               | 5-27           |
|                      | CPU331            Catalog Number IC693CPU331 .....               | 5-28           |
|                      | CPU340            Catalog Number IC693CPU340 .....               | 5-29           |
|                      | CPU341            Catalog Number IC693CPU341 .....               | 5-30           |
|                      | CPU350            Catalog Number IC693CPU350 .....               | 5-31           |
|                      | CPU351            Catalog Number IC693CPU351 .....               | 5-32           |
|                      | CPU352            Catalog Number IC693CPU352 .....               | 5-33           |
|                      | CPU360            Catalog Number IC693CPU360 .....               | 5-34           |
|                      | CPU363            Catalog Number IC693CPU363 .....               | 5-35           |
|                      | CPU364            Catalog Number IC693CPU364 .....               | 5-36           |
| <br><b>Chapter 6</b> | <br><b>Memory Backup and Backup Battery</b> .....                | <br><b>6-1</b> |
|                      | Backup Battery for RAM Memory (All Supplies) .....               | 6-1            |
|                      | Battery Replacement Instructions .....                           | 6-2            |
|                      | Battery Replacement/Memory Protection Factors .....              | 6-3            |
|                      | Factors Affecting Battery Life .....                             | 6-4            |
|                      | Low Battery Warning Methods .....                                | 6-4            |
|                      | Operating Without a Memory Backup Battery .....                  | 6-5            |
|                      | Determining Battery Age Using Battery Date Code .....            | 6-6            |
|                      | RAM Memory Battery Backup Connection Path .....                  | 6-6            |
|                      | Maintaining RAM Memory During Storage or Shipment of a CPU ..... | 6-7            |
|                      | Batteries in Power Supplies on Expansion or Remote Racks .....   | 6-9            |

# Contents

---

|                  |  |            |
|------------------|--|------------|
| <b>Chapter 7</b> | <b>Input and Output Modules</b> .....  | <b>7-1</b> |
|                  | Basic I/O Module Types .....   | 7-1        |
|                  | Discrete I/O Modules .....   | 7-3        |
|                  | Wiring Methods for 32-Point Discrete I/O Modules .....                       | 7-8        |
|                  | Analog Module Features .....   | 7-10       |
|                  | Wiring Methods for Analog Modules .....                                      | 7-11       |
|                  | I/O Module Power Supply Current Draw .....                                   | 7-12       |
|                  | I/O Module Wire Routing .....  | 7-12       |
|                  | IC693DVM300 Digital Valve Driver Module .....                                | 7-14       |
| <b>Chapter 8</b> | <b>Option Modules</b> .....  | <b>8-1</b> |
|                  | IC693CMM301 Genius Communications Module (GCM) .....                         | 8-2        |
|                  | Status LEDs .....  | 8-2        |
|                  | IC693CMM302 Enhanced Genius Communications Module (GCM+) ..                  | 8-4        |
|                  | IC693BEM331 Genius Bus Controller (GBC) .....                                | 8-6        |
|                  | IC693BEM340 FIP Bus Controller (FBC) Module .....                            | 8-10       |
|                  | IC693BEM330 FIP Remote I/O Scanner Module .....                              | 8-12       |
|                  | IC693APU301/302 Motion Mate Axis Positioning Module (APM) .....              | 8-15       |
|                  | IC693DSM302 Motion Mate Digital Servo Module (DSM302) .....                  | 8-17       |
|                  | IC693DSM314 Motion Mate Digital Servo Module (DSM314)<br>– Preliminary ..... | 8-20       |
|                  | IC693APU300 High Speed Counter (HSC) Module .....                            | 8-24       |
|                  | IC693BEM320 I/O LINK Interface (Slave) Module .....                          | 8-25       |
|                  | IC693BEM321 I/O LINK Master Module .....                                     | 8-26       |
|                  | IC693APU305 I/O Processor Module .....                                       | 8-28       |
|                  | IC693CMM321 Ethernet Interface Module .....                                  | 8-30       |
|                  | IC693PCM300/301/31 Programmable Coprocessor Module (PCM) ....                | 8-32       |
|                  | IC693CMM311 Communications Coprocessor Module (CMM) .....                    | 8-34       |
|                  | IC693ADC311 Alphanumeric Display Coprocessor (ADC) .....                     | 8-35       |
|                  | IC693TCM302/303 Temperature Control Modules (TCM) .....                      | 8-37       |
|                  | IC693PTM100/101 Power Transducer (PTM)– Preliminary .....                    | 8-40       |
| <b>Chapter 9</b> | <b>State Logic Products</b> .....  | <b>9-1</b> |
|                  | State Logic Overview .....   | 9-1        |
|                  | State Logic Products .....   | 9-1        |
|                  | AD693CMM301 State Logic Serial Communications Module (SCM) ....              | 9-2        |
|                  | IC693SLP300 State Logic Processor Module .....                               | 9-4        |
|                  | State Logic CPUs .....   | 9-8        |
|                  | State Logic CPU Data Sheets .....  | 9-13       |
|                  | CSE311                      Catalog Number IC693CSE311 .....                 | 9-14       |
|                  | CSE313                      Catalog Number IC693CSE313 .....                 | 9-15       |
|                  | CSE323                      Catalog Number IC693CSE323 .....                 | 9-16       |
|                  | CSE331                      Catalog Number IC693CSE331 .....                 | 9-17       |
|                  | CSE340                      Catalog Number IC693CSE340 .....                 | 9-18       |

|                   |  |             |
|-------------------|--|-------------|
| <b>Chapter 10</b> | <b>Cables</b> .....  | <b>10-1</b> |
|                   | Cable Data Sheets .....  | 10-8        |
|                   | IC647CBL704  |             |
|                   | Workstation Interface to Series 90 CPU (SNP Port) Cable .....    | 10-9        |
|                   | IC690CBL701  |             |
|                   | PCM, ADC, CMM to Workmaster (PC-XT) Cable .....                  | 10-13       |
|                   | PCM to Programmer Cable Installation .....                       | 10-14       |
|                   | IC690CBL702  |             |
|                   | PC-AT to PCM, ADC, CMM Cable .....                               | 10-15       |
|                   | PCM to Programmer Cable Installation .....                       | 10-16       |
|                   | IC690CBL705  |             |
|                   | Workmaster II (PS/2) to PCM, ADC, CMM Cable .....                | 10-17       |
|                   | PCM to Programmer Cable Installation .....                       | 10-18       |
|                   | IC690CBL714A Multidrop Cable .....                               | 10-19       |
|                   | Connection Diagrams for IC690CBL714A Cable .....                 | 10-21       |
|                   | IC693CBL300/301/302/312/313/314                                  |             |
|                   | I/O Bus Expansion Cables .....                                   | 10-23       |
|                   | Building Custom Length I/O Bus Expansion Cables .....            | 10-25       |
|                   | IC693CBL303  |             |
|                   | Hand-Hand Programmer and Converter (IC690ACC900) Cable ....      | 10-34       |
|                   | IC693CBL304/305  |             |
|                   | Port Expansion (WYE) Cables for PCM, ADC, and CMM .....          | 10-36       |
|                   | IC693CBL306/307  |             |
|                   | Extension Cables (50-Pin) for 32 Point Modules .....             | 10-39       |
|                   | IC693CBL308/309  |             |
|                   | I/O Cables (50-Pin) for 32 Point Modules .....                   | 10-41       |
|                   | IC693CBL310  |             |
|                   | I/OInterface Cable (24-Pin) for 32 Point Modules .....           | 10-42       |
|                   | IC693CBL311/317/319/320  |             |
|                   | I/OInterface Cables for Power Mate APM Modules .....             | 10-45       |
|                   | IC693CBL315  |             |
|                   | I/OInterface Cable (24-Pin) for 32 Point Modules .....           | 10-49       |
|                   | IC693CBL316  |             |
|                   | Serial Cable, 9-Pin D-Shell to RJ-11 Connector .....             | 10-53       |
|                   | IC693CBL321/322/323  |             |
|                   | I/OFaceplate Connector to Terminal Block Connector, 24-Pin ..... | 10-54       |
|                   | IC693CBL327/328  |             |
|                   | I/OInterface Cables with Right Angle 24-Pin Connector .....      | 10-57       |
|                   | IC693CBL329/330/331/332/333/334                                  |             |
|                   | 24-PinI/OFaceplate Connector to Terminal Block Connector .....   | 10-62       |
|                   | IC693CBL340/341  |             |
|                   | PTM Interface Cables –Preliminary Information .....              | 10-65       |

# Contents

---

|                   |  |             |
|-------------------|--|-------------|
| <b>Chapter 11</b> | <b>Programmer Hardware Products</b> .....                        | <b>11-1</b> |
|                   | Products Discussed in this Chapter .....                         | 11-1        |
|                   | IC640WMI310/320 Work Station Interface Boards .....              | 11-2        |
|                   | Replacing Workmaster Computers .....                             | 11-3        |
|                   | IC690ACC900 RS-422/RS-485 to RS-232 Converter .....              | 11-4        |
|                   | IC690ACC901 Miniconverter Kit .....                              | 11-5        |
|                   | IC693PRG300 Hand-Held Programmer (HHP) .....                     | 11-6        |
|                   | HHP Features .....   | 11-7        |
|                   | HHP Memory Card (IC693ACC303) .....                              | 11-7        |
|                   | HHP Modes of Operation .....                                     | 11-7        |
|                   | IC693PIF301/400 Personal Computer Interface (PCIF) Cards .....   | 11-8        |
|                   | IC655CCM590 Isolated Repeater/Converter .....                    | 11-10       |
|                   | IC690ACC903 Port Isolator .....                                  | 11-10       |
| <b>Chapter 12</b> | <b>System Design</b> .....                                       | <b>12-1</b> |
|                   | Introduction .....   | 12-1        |
|                   | Step 1: Planning Your System .....                               | 12-1        |
|                   | Step 2: Determining I/O Requirements .....                       | 12-1        |
|                   | Step 3: Selecting Option Modules .....                           | 12-2        |
|                   | Step 4: Selecting a CPU .....                                    | 12-4        |
|                   | Step 5: Selecting Baseplates .....                               | 12-6        |
|                   | Step 6: Selecting Power Supplies .....                           | 12-6        |
|                   | Reducing PLC Module Count by Using Other GE Fanuc Products ..... | 12-7        |
|                   | Designing For Safety .....                                       | 12-8        |
|                   | Number of Modules Per Series 90-30 PLC System .....              | 12-11       |
|                   | Calculating Power Supply Loading .....                           | 12-12       |
|                   | Scan (Sweep) Time Calculation .....                              | 12-16       |
|                   | Calculating PLC Heat Dissipation .....                           | 12-16       |
|                   | System Layout Guidelines .....                                   | 12-17       |
|                   | Series 90-30 PLC Layout Example .....                            | 12-20       |
|                   | PLC Mounting Position .....                                      | 12-21       |
| <b>Chapter 13</b> | <b>Maintenance and Troubleshooting</b> .....                     | <b>13-1</b> |
|                   | Troubleshooting Features of Series 90-30 Hardware .....          | 13-1        |
|                   | Module LED Indicators .....                                      | 13-2        |
|                   | Troubleshooting Features of Programming Software .....           | 13-3        |
|                   | Replacing Modules .....  | 13-4        |
|                   | Series 90-30 Product Repair .....                                | 13-4        |
|                   | Module Fuse List .....   | 13-5        |
|                   | Spare/Replacement Parts .....                                    | 13-6        |
|                   | Preventive Maintenance Suggestions .....                         | 13-7        |
|                   | Getting Additional Help and Information .....                    | 13-8        |

|                   |   |            |
|-------------------|---|------------|
| <b>Appendix A</b> | <b>Glossary</b> .....                                     | <b>A-1</b> |
|                   | Glossary of Terms for the Series 90-30 PLC .....          | A-1        |
| <b>Appendix B</b> | <b>Acronyms and Abbreviations</b> .....                   | <b>B-1</b> |
| <b>Appendix C</b> | <b>Serial Port and Cables</b> .....                       | <b>C-1</b> |
|                   | What this Appendix Contains .....                         | C-1        |
|                   | RS-422 Interface .....                                    | C-1        |
|                   | Cable and Connector Specifications .....                  | C-2        |
|                   | Series 90 PLC Serial Port .....                           | C-3        |
|                   | Workmaster Serial Port .....                              | C-5        |
|                   | IBM-AT/XTSerialPort .....                                 | C-6        |
|                   | RS-232/RS-485Converter .....                              | C-7        |
|                   | Serial Cable Diagrams .....                               | C-7        |
|                   | RS-232 Point-to-Point Connections .....                   | C-7        |
|                   | RS-422 Point-to-Point Connection .....                    | C-10       |
|                   | Multidrop Connections .....                               | C-11       |
| <b>Appendix D</b> | <b>IC690ACC900 Converter</b> .....                        | <b>D-1</b> |
|                   | Features .....  | D-1        |
|                   | Functions .....   | D-1        |
|                   | Location in System .....                                  | D-1        |
|                   | Installation .....  | D-2        |
|                   | Cable Description .....                                   | D-3        |
|                   | Logic Diagram .....                                       | D-6        |
|                   | Jumper Configuration .....                                | D-7        |
| <b>Appendix E</b> | <b>IC655CCM590 Isolated Repeater/Converter</b> .....      | <b>E-1</b> |
|                   | Description of the Isolated Repeater/Converter .....      | E-1        |
|                   | Logic Diagram of the Isolated Repeater/Converter .....    | E-3        |
|                   | Pin Assignments for the Isolated Repeater/Converter ..... | E-4        |
|                   | System Configurations .....                               | E-5        |
|                   | Cable Diagrams .....                                      | E-7        |

# Contents

---

|                   |  |            |
|-------------------|--|------------|
| <b>Appendix F</b> | <b>IC690ACC901 Miniconverter Kit</b> .....                         | <b>F-1</b> |
| <b>Appendix G</b> | <b>IC690ACC903 Port Isolator</b> .....                             | <b>G-1</b> |
| <b>Appendix H</b> | <b>Series 90-30 Heat Dissipation</b> .....                         | <b>H-1</b> |
| <b>Appendix I</b> | <b>Catalog Number to Publication Cross-Reference</b> .....         | <b>I-1</b> |
| <b>Appendix J</b> | <b>Terminal Block Quick Connect Components</b> .....               | <b>J-1</b> |
|                   | Terminal Block Quick Connect Components for 16-Point Modules ..... | J-2        |
|                   | Terminal Blocks .....  | J-2        |
|                   | Cable Current Rating .....   | J-2        |
|                   | Cable Selection and Cross-Reference .....                          | J-3        |
|                   | I/OFace Plate for 16-Point Modules .....                           | J-3        |
|                   | I/OFace Plate Installation .....                                   | J-3        |
|                   | Module Wiring Information .....                                    | J-4        |
|                   | Cable Information .....  | J-4        |
|                   | Connector Pin Orientation and Connection to Module Terminal .....  | J-5        |
|                   | Terminal Block Information .....                                   | J-5        |
|                   | Terminal Block Quick Connect Components for 32-Point Modules ..... | J-11       |
|                   | Terminal Block .....   | J-11       |
|                   | Cable Selection and Cross-Reference .....                          | J-12       |
|                   | Cable Current Rating .....   | J-12       |
|                   | Cable Data .....   | J-12       |
|                   | Terminal Block Data .....  | J-12       |
| <b>Appendix K</b> | <b>SNP Multidrop</b> .....   | <b>K-1</b> |
|                   | SNP Multidrop Overview .....                                       | K-1        |
|                   | Cable and Connector Specifications .....                           | K-2        |
|                   | SNP Multidrop Examples .....                                       | K-4        |
|                   | Configuring and Connecting a Programmer to a Multidrop Network ..  | K-5        |
|                   | SNP Multidrop Troubleshooting .....                                | K-6        |
| <b>Appendix L</b> | <b>Ethernet Transceivers</b> .....                                 | <b>L-1</b> |
|                   | IC649AEA102 Ethernet 10BASE-T Transceiver .....                    | L-1        |
|                   | IC649AEA103 Ethernet 10BASE2 Transceiver .....                     | L-2        |
| <b>Appendix M</b> | <b>Tables and Formulas</b> .....                                   | <b>M-1</b> |
| <b>Appendix N</b> | <b>44A720084-001 EMI Line Filter</b> .....                         | <b>N-1</b> |
|                   | 44A720084-001 Optional EMI Line Filter .....                       | N-1        |

|   |      |
|---|------|
| Figure 1-1. Five-Slot CPU Baseplate .....   | 1-3  |
| Figure 1-2. Power Supply Module .....   | 1-3  |
| Figure 1-3. CPU Module .....  | 1-4  |
| Figure 1-4. I/O Module .....  | 1-4  |
| Figure 1-5. Assembling the System .....   | 1-5  |
| Figure 1-6. A Basic System .....  | 1-6  |
| Figure 1-7. Ten-Slot Rack .....   | 1-7  |
| Figure 1-8. I/O Bus Expansion Cable .....   | 1-7  |
| Figure 1-9. Connecting Expansion and Remote Baseplates .....                          | 1-8  |
| Figure 1-10. Connecting PLCs Using GBC or CMM Modules .....                           | 1-9  |
| Figure 2-1. Features of Series 90-30 Module .....                                     | 2-2  |
| Figure 2-2. Installing a Module .....   | 2-3  |
| Figure 2-3. Removing a Module .....   | 2-4  |
| Figure 2-4. Installing an I/O Module's Terminal Board .....                           | 2-5  |
| Figure 2-5. Removing a Module's Terminal Board .....                                  | 2-6  |
| Figure 2-6. Terminal Board with Holding Screws .....                                  | 2-7  |
| Figure 2-7. IC693ACC308 Front Mount Adapter Bracket Installation .....                | 2-9  |
| Figure 2-8. Dimensions for 19I Rack Mounting Using IC693ACC308 Adapter Bracket .....  | 2-9  |
| Figure 2-9. IC693ACC313 Recessed Mount Adapter Bracket .....                          | 2-10 |
| Figure 2-10. Recommended System Grounding .....                                       | 2-11 |
| Figure 2-11. Baseplate Grounding .....  | 2-12 |
| Figure 2-12. CPU 351 or 352 - Attaching Ground Wire .....                             | 2-14 |
| Figure 2-13. CPU 351 or 352 - Mounting Grounding Bracket .....                        | 2-15 |
| Figure 2-14. CPU 363 or CPU364 - Attaching Ground Wire .....                          | 2-16 |
| Figure 2-15. Power Supply Terminal Boards .....                                       | 2-24 |
| Figure 2-16. Overvoltage Protection Devices and Jumper Strap .....                    | 2-24 |
| Figure 3-1. Common Baseplate Features .....   | 3-2  |
| Figure 3-2. Models IC693CPU311 and IC693CPU313 (5-Slot) Embedded CPU Baseplates ..... | 3-5  |
| Figure 3-3. Model IC693CPU323 (10-slot) Embedded CPU Baseplate .....                  | 3-5  |
| Figure 3-4. IC693CHS397 5-Slot Modular CPU Baseplate .....                            | 3-6  |
| Figure 3-5. IC693CHS391 10-Slot Modular CPU Baseplate .....                           | 3-7  |
| Figure 3-6. IC693CHS398 5-Slot Expansion Baseplate .....                              | 3-8  |
| Figure 3-7. IC693CHS392 10-Slot Expansion Baseplate .....                             | 3-9  |
| Figure 3-8. IC693CHS399 5-Slot Remote Baseplate .....                                 | 3-10 |
| Figure 3-9. IC693CHS393 10-Slot Remote Baseplate .....                                | 3-11 |
| Figure 3-10. I/O Bus Expansion Cables .....   | 3-12 |
| Figure 3-11. Rack Number Selection Switch (Shown with Rack 2 Selected) .....          | 3-15 |

# Contents

---

|   |      |
|---|------|
| Figure 3-12. Example of Connecting Expansion Baseplates .....   | 3-16 |
| Figure 3-13. Example of Connecting Expansion and Remote Baseplates .....                                    | 3-17 |
| Figure 3-14. Model 311 and 313 5-Slot Baseplate Dimensions and Spacing Requirements .....                   | 3-18 |
| Figure 3-15. Model 323 10-Slot Baseplate Dimensions and Spacing Requirements .....                          | 3-19 |
| Figure 3-16. Modular CPU, Expansion, and Remote 5-Slot Baseplate Dimensions and Spacing Requirements .....  | 3-19 |
| Figure 3-17. Modular CPU, Expansion, and Remote 10-Slot Baseplate Dimensions and Spacing Requirements ..... | 3-20 |
| Figure 3-18. IC693ACC308 Front Mount Adapter Bracket Installation .....                                     | 3-22 |
| Figure 3-19. Dimensions for 19I Rack Mounting Using IC693ACC308 Adapter Bracket .....                       | 3-23 |
| Figure 3-20. IC693ACC313 Recessed Mount Adapter Bracket .....   | 3-23 |
| Figure 4-1. Standard AC/DC Input Power Supply - IC693PWR321 .....   | 4-2  |
| Figure 4-2. High Capacity AC/DC Input Power Supply - IC693PWR330 .....                                      | 4-4  |
| Figure 4-3. Overvoltage Protection Devices and Jumper Strap .....   | 4-6  |
| Figure 4-4. Series 90-30 24/48 VDC Input Power Supply - IC693PWR322 .....                                   | 4-7  |
| Figure 4-5. Typical Efficiency Curve for 24/48 VDC Power Supply .....                                       | 4-8  |
| Figure 4-6. Series 90-30 48 VDC Input Power Supply - IC693PWR328 .....                                      | 4-10 |
| Figure 4-7. Typical Efficiency Curve for IC693PWR328 Power Supply .....                                     | 4-11 |
| Figure 4-8. Series 90-30 24 VDC Input High Capacity Power Supply - IC693PWR331 .....                        | 4-13 |
| Figure 4-9. 5 VDC Current Output Derating for Temperatures above 50C (122F) .....                           | 4-14 |
| Figure 4-10. Overvoltage Protection Devices and Jumper Strap .....  | 4-18 |
| Figure 4-11. Interconnection of Power Supplies .....  | 4-18 |
| Figure 4-12. Timing Diagram for all Series 90-30 Power Supplies .....                                       | 4-19 |
| Figure 4-13. Serial Port Connector .....  | 4-20 |
| Figure 4-14. Backup Battery for RAM Memory .....  | 4-21 |
| Figure 5-1. Models 311 and 313 (5-Slot) Embedded CPU Baseplates .....                                       | 5-2  |
| Figure 5-2. IC693CHS397 5-Slot Modular CPU Baseplate .....  | 5-3  |
| Figure 5-3. CPU Serial Port Connector on Power Supply .....   | 5-4  |
| Figure 5-4. CPUs 351, 352, and 363 .....  | 5-19 |
| Figure 6-1. Backup Battery for RAM Memory .....   | 6-1  |
| Figure 6-2. Installing the Battery Accessory Kit .....  | 6-8  |
| Figure 7-1. Example of Series 90-30 Standard Density Discrete Output Module .....                           | 7-4  |
| Figure 7-2. Example of 32-Point I/O Module (IC693MDL654) With Dual Connectors .....                         | 7-6  |
| Figure 7-3. Example of 32-Point I/O Module (IC693MDL653) With Single Connector .....                        | 7-7  |
| Figure 7-4. 50-PIN, 32 Point I/O Module Connection Method .....   | 7-8  |
| Figure 7-5. Example of Series 90-30 Analog Current Output Module .....                                      | 7-11 |
| Figure 7-6. IC693DVM300 Digital Valve Driver Module .....   | 7-14 |
| Figure 8-1. The IC693CMM301 GCM Module .....  | 8-2  |

|  |       |
|--|-------|
| Figure 8-2. Genius Bus Wiring Schematic .....  | 8-3   |
| Figure 8-3. Example of Genius Communications Network .....                                 | 8-3   |
| Figure 8-4. Enhanced Genius Communications Module .....                                    | 8-4   |
| Figure 8-5. Genius Bus Controller Module .....   | 8-6   |
| Figure 8-6. Example of FIP I/O System Configuration .....                                  | 8-10  |
| Figure 8-7. Series 90-30 FIP Bus Controller .....  | 8-11  |
| Figure 8-8. Example of FIP Remote I/O Scanner System Configuration .....                   | 8-12  |
| Figure 8-9. FIP Bus Interface Module .....   | 8-13  |
| Figure 8-10. Motion Mate APM Module .....  | 8-15  |
| Figure 8-11. Example of Motion Mate APM Servo System .....                                 | 8-16  |
| Figure 8-12. Motion Mate DSM302 Module .....   | 8-17  |
| Figure 8-13. Motion Mate DSM314 Module .....   | 8-20  |
| Figure 8-14. High Speed Counter (HSC) .....  | 8-24  |
| Figure 8-15. Example of a Series 90-30 PLC in a Fanuc I/O LINK Configuration .....         | 8-25  |
| Figure 8-16. Example of I/O LINK Master System Configuration .....                         | 8-26  |
| Figure 8-17. I/O Processor Module .....  | 8-28  |
| Figure 8-18. Ethernet Interface Module .....   | 8-30  |
| Figure 8-19. Programmable Coprocessor Module (PCM) .....                                   | 8-32  |
| Figure 8-20. Communications Control Module .....   | 8-34  |
| Figure 8-21. Alphanumeric Display Coprocessor Module (ADC) .....                           | 8-35  |
| Figure 8-22. IC693TCM302/303 Temperature Control Module (TCM) .....                        | 8-37  |
| Figure 8-23. IC693PTM100/101 Components .....  | 8-41  |
| Figure 8-24. IC693PTM100/101 Component Mounting .....                                      | 8-42  |
| Figure 9-1. AD693CMM301 State Logic Serial Communications Module .....                     | 9-2   |
| Figure 9-2. IC693CBL305 WYE Cable .....  | 9-3   |
| Figure 9-3. IC693SLP300 State Logic Processor Module for Series 90-30 .....                | 9-4   |
| Figure 9-4. State Logic Processor Module User Details .....                                | 9-6   |
| Figure 9-5. Model CSE311 or CSE313 5-Slot Embedded CPU Baseplate .....                     | 9-9   |
| Figure 9-6. Model CSE323 10-Slot Embedded CPU Baseplate .....                              | 9-9   |
| Figure 9-7. CPU Models CSE 331 or CSE 340 .....  | 9-10  |
| Figure 9-8. Serial Port Connector .....  | 9-11  |
| Figure 10-1. Serial Port to Work Station Interface Board Cable Connection .....            | 10-9  |
| Figure 10-2. Series 90 PLC to Workmaster II Serial Cable .....                             | 10-10 |
| Figure 10-3. Example of Multidrop Configuration with Converter .....                       | 10-11 |
| Figure 10-4. Series 90 PLC to Programmer 8-Wire Multidrop, Serial Data Configuration ..... | 10-12 |
| Figure 10-5. PCM, ADC, or CMM to Workmaster or PC-XT Serial Cable .....                    | 10-13 |
| Figure 10-6. PCM to Workmaster Computer or PC-XT Personal Computer .....                   | 10-14 |

# Contents

---

|  |       |
|--|-------|
| Figure 10-7. PCM, ADC, or CMM to Workmaster or PC-AT Serial Cable .....                          | 10-15 |
| Figure 10-8. PCM to PC-AT Personal Computer .....  | 10-16 |
| Figure 10-9. PCM, ADC, or CMM to Workmaster II or PS/2 Serial Cable .....                        | 10-17 |
| Figure 10-10. PCM to Workmaster II Computer or PS/2 Computer .....                               | 10-18 |
| Figure 10-11. Connecting Diagram for Multidrop Cable IC690CBL714A .....                          | 10-20 |
| Figure 10-12. Multidrop Arrangement for Series 90-30 Redundant System .....                      | 10-21 |
| Figure 10-13. Connecting CPU and APM to Programmer with IC690CBL714A Cable .....                 | 10-21 |
| Figure 10-14. Multidrop Arrangement for Series 90-70 TMR Redundant System .....                  | 10-22 |
| Figure 10-15. Detail of I/O Bus Expansion Cables .....   | 10-23 |
| Figure 10-16. How to use Split-Ring Ferrules for Foil and Braided Cable Shield .....             | 10-27 |
| Figure 10-17. Point-To-Point Cable Wiring for Continuous Shield Custom Length Cables .....       | 10-29 |
| Figure 10-18. Point-To-Point Cable Wiring Diagram for Applications Requiring Less Noise Immunity | 10-29 |
| Figure 10-19. Earlier Versions of Remote Baseplate Custom WYE Cable Wiring Diagram .....         | 10-30 |
| Figure 10-20. Current Remote baseplate (IC693CHS393/399) Custom Wye Cable Wiring Diagram .       | 10-31 |
| Figure 10-21. Example of Connecting Expansion Baseplates .....                                   | 10-32 |
| Figure 10-22. Example of Connecting Expansion and Remote Baseplates .....                        | 10-33 |
| Figure 10-23. Wiring Connections for IC693CBL303 and Custom-Built Cables .....                   | 10-35 |
| Figure 10-24. Hand-Held Programmer Cable Connection to a Series 90-30 PLC .....                  | 10-35 |
| Figure 10-25. Wye Cable .....  | 10-36 |
| Figure 10-26. Wye Cable Connections .....  | 10-37 |
| Figure 10-27. 32 Point I/O Module to Weidmuller Terminal Block Assembly .....                    | 10-40 |
| Figure 10-28. IC693CBL310 Cable .....  | 10-42 |
| Figure 10-29. Dimensions for Depth of Connector in front of PLC .....                            | 10-44 |
| Figure 10-30. I/O Connector Cable Specifications .....   | 10-45 |
| Figure 10-31. IC693CBL315 Cable .....  | 10-49 |
| Figure 10-32. Dimensions for Depth of Connector in front of PLC .....                            | 10-52 |
| Figure 10-33. IC693CBL316A Serial Cable Illustration and Connector Pinouts .....                 | 10-53 |
| Figure 10-34. Connector Orientation on I/O Faceplate .....                                       | 10-55 |
| Figure 10-35. I/O Faceplate to Terminal Block Cable .....  | 10-55 |
| Figure 10-36. Dimensions for Depth of Connector in front of PLC .....                            | 10-56 |
| Figure 10-37. IC693CBL327/328 Cables .....   | 10-57 |
| Figure 10-38. Dimension for Depth of Connector for IC693CBL327/328 .....                         | 10-58 |
| Figure 10-39. Dimensions for Depth of Connector in front of PLC for Custom Built Cables .....    | 10-61 |
| Figure 10-40. IC693CBL329/330/331/332/333/334 Cables .....                                       | 10-62 |
| Figure 10-41. Dimension for Depth of Connector .....   | 10-63 |
| Figure 10-42. IC693CBL340/341 PTM Interface Cables .....   | 10-65 |
| Figure 10-43. IC693PTM100 PTM Component Mounting .....   | 10-65 |

|  |       |
|--|-------|
| Figure 11-1. WSI Board for the Workmaster II Computer .....                              | 11-2  |
| Figure 11-2. Location of WSI in a Series II 90-30 PLC System .....                       | 11-2  |
| Figure 11-3. Example of IC690ACC900 Converter Connection .....                           | 11-4  |
| Figure 11-4. IC690ACC901 Series 90 SNP Port to RS-232 Adapter .....                      | 11-5  |
| Figure 11-5. Hand-Held Programmer for the Series 90-30 PLC .....                         | 11-6  |
| Figure 11-6. Example of PCIF Interface to Series 90-30 I/O .....                         | 11-8  |
| Figure 12-1. Hard-Wired MCR Circuit Example .....  | 12-9  |
| Figure 12-2. Allowable Location of Modules .....   | 12-19 |
| Figure 12-3. Series 90-30 Example Layout .....   | 12-20 |
| Figure 12-4. Recommended PLC Mounting Orientation .....                                  | 12-21 |
| Figure 12-5. Derated PLC Mounting Orientation .....                                      | 12-21 |
| Figure 13-1. Relationship of Indicator Lights to Terminal Board Connections .....        | 13-1  |
| Figure C-1. Series 90 PLC, RS-422 Serial Port Connector Configuration .....              | C-3   |
| Figure C-2. Workmaster RS-232 Serial Port Connector Configuration .....                  | C-5   |
| Figure C-3. IBM-AT/XTSerialPort .....  | C-6   |
| Figure C-4. IBM-AT (compatibles) Personal Computer to Series 90 PLCs .....               | C-8   |
| Figure C-5. Workmaster or IBM-XT (compatibles) Personal Computer to Series 90 PLCs ..... | C-9   |
| Figure C-6. Typical RS-422, Host to PLC Connection, with Handshaking .....               | C-10  |
| Figure C-7. Workmaster II/Series 90 PLC Multidrop Connection .....                       | C-11  |
| Figure C-8. Workmaster/Series 90 PLC Multidrop Connection .....                          | C-12  |
| Figure C-9. IBM-AT/Series 90 PLC Multidrop Connection .....                              | C-12  |
| Figure C-10. IBM-XT/Series 90 PLC Multidrop Connection .....                             | C-13  |
| Figure D-1. Front and Rear View of Converter .....                                       | D-2   |
| Figure D-2. Typical Configuration with Series 90-70 PLC .....                            | D-3   |
| Figure D-3. Typical Configuration with Series 90-30 PLC .....                            | D-4   |
| Figure D-4. RS-422/RS-485 to RS-232 Converter Logic Diagram .....                        | D-6   |
| Figure D-5. Location of Jumpers for User Options .....                                   | D-7   |
| Figure E-1. Isolated/Repeater Converter .....  | E-2   |
| Figure E-2. RS-422 Isolated Repeater/RS-232 Converter Logic Diagram .....                | E-3   |
| Figure E-3. Example RS-422 Isolated Repeater/RS-232 Converter Connection .....           | E-5   |
| Figure E-4. Simple System Configuration Using the Isolated Repeater/Converter .....      | E-6   |
| Figure E-5. Complex System Configuration Using the Isolated Repeater/Converter .....     | E-6   |
| Figure E-6. Cable A; RS-232 CMM To Converter .....                                       | E-7   |
| Figure E-7. Cable B; RS-422 CMM To Converter .....                                       | E-7   |
| Figure E-8. Cable C; RS422 Twisted Pair .....  | E-8   |
| Figure E-9. Cable D; RS-422 Twisted Pair .....   | E-9   |
| Figure E-10. Cable E; RS-232 Converter to CMM .....                                      | E-9   |

# Contents

---

|  |      |
|--|------|
| Figure F-1. Series 90 SNP to RS-232 Miniconverter .....                              | F-1  |
| Figure F-2. Miniconverter to PC-AT .....   | F-3  |
| Figure F-3. Miniconverter to Workmaster II, PC-XTPS/2 .....                          | F-3  |
| Figure F-4. Miniconverter to 9-Pin Workmaster or PC-XT Computer .....                | F-3  |
| Figure J-1. Typical TBQC Terminal Block .....  | J-1  |
| Figure J-2. TBQC Faceplate .....   | J-5  |
| Figure J-3. IC693ACC329 TBQC Terminal Block .....                                    | J-6  |
| Figure J-4. IC693ACC330 TBQC Terminal Block .....                                    | J-7  |
| Figure J-5. IC693ACC331 TBQC Terminal Block .....                                    | J-8  |
| Figure J-6. IC693ACC332 TBQC Terminal Block .....                                    | J-9  |
| Figure J-7. IC693ACC333 TBQC Terminal Block .....                                    | J-10 |
| Figure J-8. IC693MDL654 32-Point Module .....  | J-11 |
| Figure J-9. IC693ACC337 TBQC Terminal Block .....                                    | J-13 |
| Figure K-1. Series 90-30 Multidrop Example .....                                     | K-1  |
| Figure K-2. Multidrop Cable Wiring Diagram .....                                     | K-3  |
| Figure K-3. Connecting CPU and APM to Programmer with IC690CBL714A Cable .....       | K-4  |
| Figure K-4. Multidrop Arrangement for Series 90-70 TMR Redundant System .....        | K-4  |
| Figure K-5. Multidrop Arrangement for Series 90-30 Redundant System .....            | K-5  |
| Figure L-1. IC649AEA102 Ethernet 10BASE-T Transceiver .....                          | L-1  |
| Figure L-2. IC649AEA103 Ethernet 10BASE2 Transceiver .....                           | L-2  |
| Figure N-1. 44A720084-001 Line Filter Connections to Series 90-30 Power Supply ..... | N-1  |
| Figure N-2. Equivalent Circuit for 44A720084-001 Line Filter .....                   | N-2  |
| Figure N-3. 44A720084-001 Line Filter Mounting Dimensions .....                      | N-2  |

|  |       |
|--|-------|
| Table 3-1. Rack Number Selection Switch Settings .....                                 | 3-14  |
| Table 3-2. Series 90-30 Baseplate Comparison .....                                     | 3-24  |
| Table 4-1. Power Supply Comparison Table .....   | 4-1   |
| Table 4-2. IC693PWR321 Power Supply Capacities .....                                   | 4-2   |
| Table 4-3. Specifications for IC693PWR321 Standard AC/DC Input Power Supply .....      | 4-3   |
| Table 4-4. IC693PWR330 Power Supply Capacities .....                                   | 4-4   |
| Table 4-5. Specifications for IC693PWR330 High Capacity AC/DC Input Power Supply ..... | 4-5   |
| Table 4-6. IC693PWR322 Power Supply Capacities .....                                   | 4-7   |
| Table 4-7. Specifications for IC693PWR322 Power Supply .....                           | 4-8   |
| Table 4-8. IC693PWR328 Power Supply Capacities .....                                   | 4-10  |
| Table 4-9. Specifications for IC693PWR328 Power Supply .....                           | 4-11  |
| Table 4-10. IC693PWR331 Power Supply Capacities .....                                  | 4-13  |
| Table 4-11. Specifications for IC693PWR331 Power Supply .....                          | 4-14  |
| Table 5-1. EPROM and EEPROM Catalog Numbers .....                                      | 5-9   |
| Table 5-2. Series 90-30 CPU Capacities .....   | 5-10  |
| Table 5-3. Range and Size of User References for CPU Models 311-341 .....              | 5-11  |
| Table 5-4. Range and Size of User References for CPU Models 350 through 364 .....      | 5-12  |
| Table 5-5. Port 1 (RS-232) .....   | 5-21  |
| Table 5-6. Port 2 (RS-485) .....   | 5-21  |
| Table 7-1. IC693DVM300 Specifications .....  | 7-15  |
| Table 7-2. IC693DVM300 Connections .....   | 7-16  |
| Table 7-3. Series 90-30 Discrete I/O Modules .....                                     | 7-17  |
| Table 7-4. Series 90-30 Analog I/O Modules .....                                       | 7-17  |
| Table 8-1. Comparison of TCM302 and TCM303 .....                                       | 8-39  |
| Table 9-1. System Specifications for Series 90-30 State Logic CPUs .....               | 9-12  |
| Table 10-1. Series 90-30 Cable Cross-Reference .....                                   | 10-1  |
| Table 10-2. Expansion Port Pin Assignments .....                                       | 10-26 |
| Table 10-3. Wire List for 32 Point I/O Cables .....                                    | 10-41 |
| Table 10-4. Wire List for 24-Pin Connectors .....                                      | 10-43 |
| Table 10-5. Catalog Numbers for 24-Pin Connector Kits .....                            | 10-46 |
| Table 10-6. I/O Cable Wire Coding for IC693CBL311 and IC693CBL319 .....                | 10-47 |
| Table 10-7. I/O Cable Wire Coding for IC693CBL317 and IC693CBL320 .....                | 10-48 |
| Table 10-8. Catalog Numbers for 24-Pin Connector Kits .....                            | 10-50 |
| Table 10-9. Wire List for 24-Pin Connectors .....                                      | 10-51 |
| Table 10-10. Catalog Numbers for 24-Pin Connector Kits .....                           | 10-59 |
| Table 10-11. Wire List for 24-Pin Connectors .....                                     | 10-60 |
| Table 10-12. TBQC Cable Cross-Reference Table .....                                    | 10-63 |

# Contents

---

|   |       |
|---|-------|
| Table 11-1. Personal Computer Interface Card Comparison Table .....         | 11-8  |
| Table 12-1. Power Supply Feature Comparison Table .....                     | 12-7  |
| Table 12-2. Maximum Number of Modules Per System .....                      | 12-11 |
| Table 12-3. Load Requirements (in milliamps) .....                          | 12-13 |
| Table 13-1. Fuse List for Series 90-30 Modules .....                        | 13-5  |
| Table 13-2. Spare/Replacement Parts .....                                   | 13-6  |
| Table C-1. Connector/Cable Specifications .....                             | C-2   |
| Table C-2. Series 90 PLC, RS-422 Serial Port Pin-out .....                  | C-4   |
| Table C-3. Workmaster RS-232 Serial Port Pins-out .....                     | C-5   |
| Table C-4. IBM-AT/XT Serial Port Pins-out .....                             | C-6   |
| Table D-1. RS-232 Interface for Converter .....                             | D-4   |
| Table D-2. RS-422/RS-485 Interface for Converter .....                      | D-5   |
| Table D-3. Jumper Configuration for RS-422/RS-485 to RS-232 Converter ..... | D-8   |
| Table D-4. Specifications for IC690ACC900 Converter .....                   | D-9   |
| Table E-1. Isolated Repeater/Converter Pin Assignments .....                | E-4   |
| Table F-1. Miniconverter RS-232 Port .....                                  | F-2   |
| Table F-2. Miniconverter RS-422 Port .....                                  | F-2   |
| Table F-3. Miniconverter Specifications .....                               | F-4   |
| Table J-1. TBQC Terminal Block Selection Table .....                        | J-2   |
| Table K-1. Connector and Cable Specifications .....                         | K-2   |

# Chapter 1

## Overview of the Series 90-30 PLC

[efesotomasyon.com](http://efesotomasyon.com)

---

---

The Series 90™-30 Programmable Logic Controller (PLC) is a member of the GE Fanuc Series 90™ PLC family.

### The Basic Parts of a Series 90-30 PLC

The Series 90-30 PLC is very versatile because (1) it is programmable, and (2) it is assembled from a wide variety of modular, plug-together components. Therefore, by choosing the correct components and developing an appropriate program, the PLC can be used for an almost unlimited variety of applications. Although there are many choices of individual hardware components to use in a system, there are just a few basic categories. Each of these component categories is covered in detail in a separate chapter in this manual. They are introduced in this chapter so you can see how they fit together:

- Baseplates
- Power Supplies
- CPUs
- I/O Modules
- Option Modules
- Cables

#### Baseplates

The baseplates are the foundation of the PLC system because most other components mount on them. As a basic minimum, every system has at least one baseplate, which usually contains the CPU (in which case, it is referred to as “the CPU Baseplate”). Many systems require more modules than can be mounted on one baseplate, so there are also Expansion and Remote baseplates that connect together. So, there are three different categories of baseplates: CPU, Expansion, and Remote. Also, each of these is available in two sizes, 5-slot and 10-slot, named according to the number of modules they can hold.

#### Power Supply Modules

Every baseplate, whether a CPU, Expansion, or Remote baseplate, and whether a 5-slot or 10-slot size, must have its own power supply. The power supply always mounts in a baseplate’s left-most slot. There are several power supply models available to meet a variety of requirements.

## CPUs

The CPU is the manager of the PLC. Every PLC system must have one. A CPU uses the instructions in its firmware and application program to direct the PLC's operation and to monitor the the system to make sure there are no basic faults. Some Series 90-30 CPUs are built into baseplates, but most are contained in plug-in modules. In some cases, the CPU resides in a Personal Computer using a Personal Computer Interface Card that interfaces to Series 90-30 Input, Output, and Option modules.

## Input and Output (I/O) Modules

These modules enable the PLC to interface with input and output field devices such as switches, sensors, relays, and solenoids. They are available in both discrete and analog types.

## Option Modules

These modules extend the capability of the PLC beyond the basic functions. These provide such things as communications and networking options, motion control, high speed counting, temperature control, interfacing to operator interface stations, etc.

## Cables

These connect the PLC components together or to other systems. Many standard prefabricated cables are available from GE Fanuc. They are primarily used to:

- Interconnect baseplates
- Connect a programmer to the CPU or to an option module
- Connect option modules to field devices or other systems.

## Assembling a Basic Series 90-30 PLC System

Let's assemble, on paper, a basic system using the following components:

- Baseplate
- Power Supply module
- CPU module
- Some I/O modules

We'll start with the **baseplate**. To keep it simple, we'll use a 5-slot size. Note that a 5-slot baseplate actually has six slots, but the power supply slot is not numbered. Note also, that this baseplate has a CPU slot, which is slot number 1, and it has an expansion connector on the right end, which is used for connecting to another baseplate if the system has more than one baseplate.

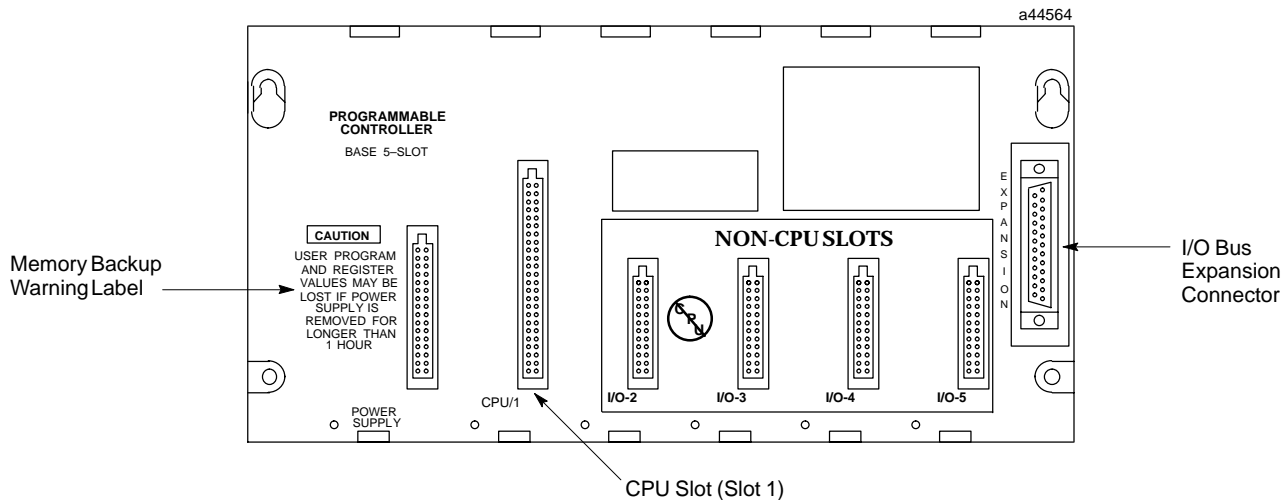

Figure 1-1. Five-Slot CPU Baseplate

Next, we'll add a **power supply** module. It mounts in the unnumbered slot on the left end of the baseplate. This slot has a unique connector that will only fit a power supply module.

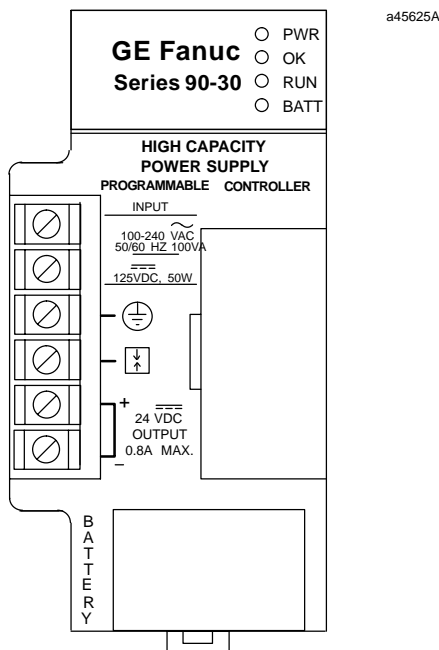

Figure 1-2. Power Supply Module

Then, a **CPU module**. A CPU module can only mount in baseplate slot 1, next to the power supply. Slot 1 has a unique connector that will only fit CPU or special Option modules.



Figure 1-3. CPU Module

To finish, we will add some **I/O modules** to baseplate slots 2 through 5.

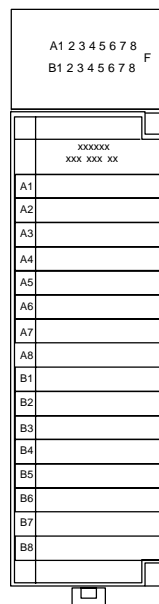

Figure 1-4. I/O Module

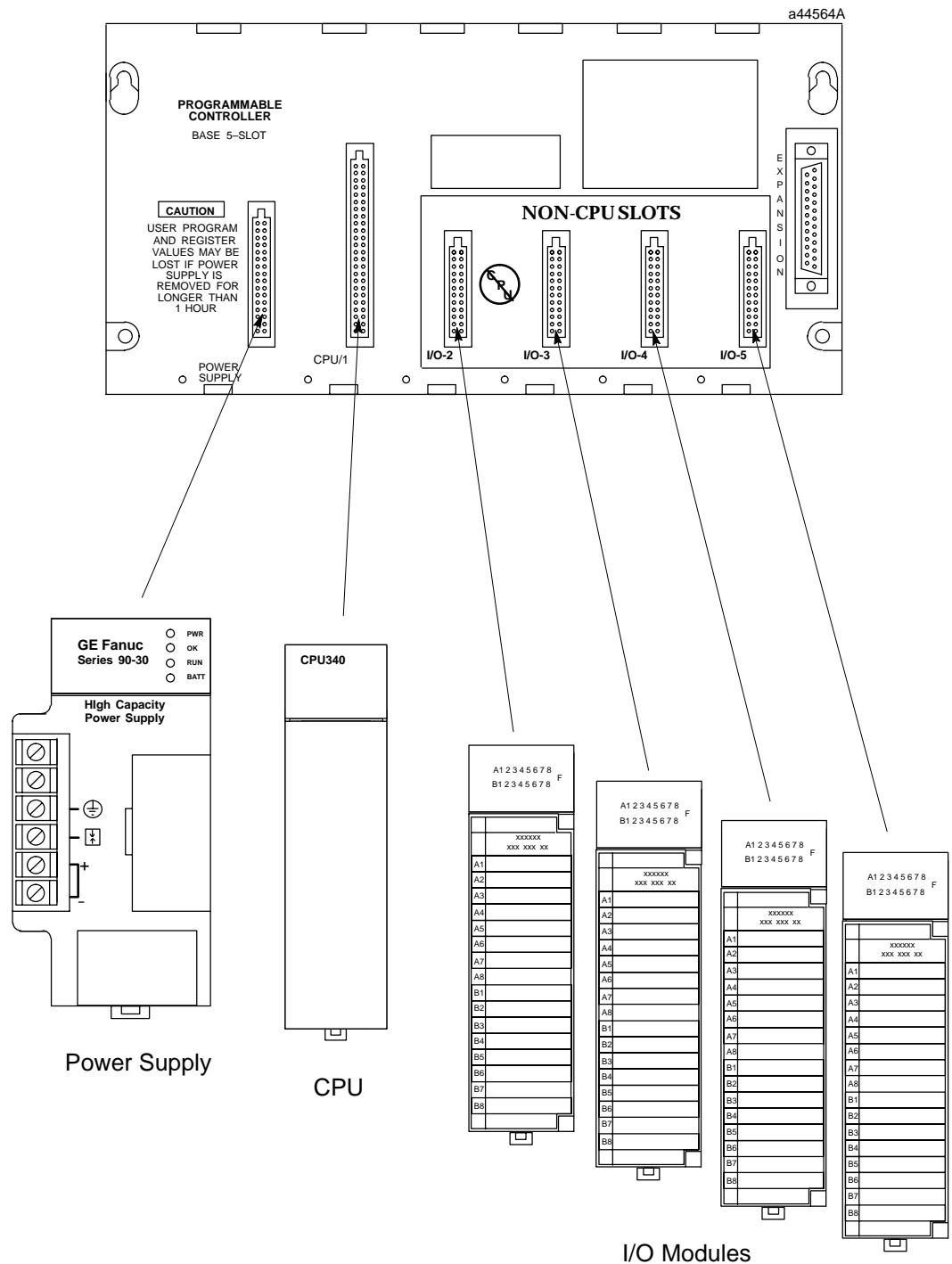

Figure 1-5. Assembling the System

**When assembled, the system will look like ...**

this:

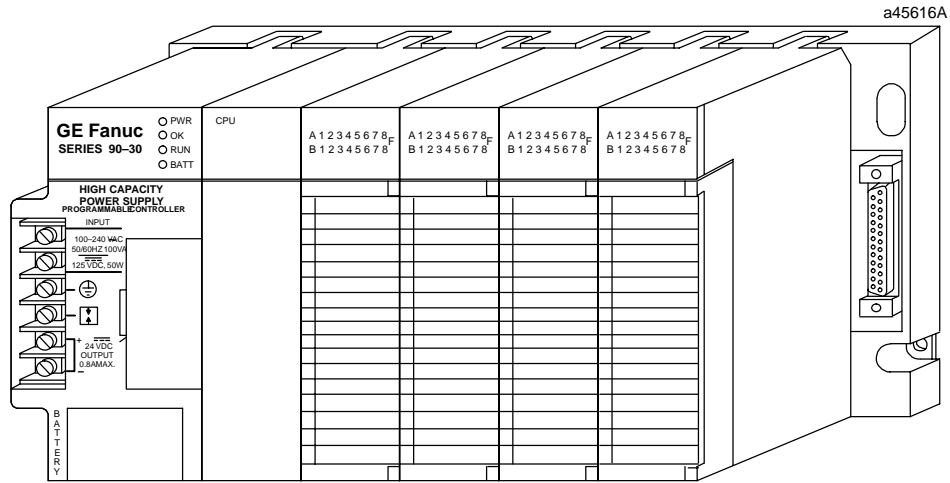

Figure 1-6. A Basic System

An assembly of baseplate and modules such as this one is called a “Rack.”

### What else would be needed to make this basic system functional?

To make this basic system functional, you would need:

- **Mounting.** Safe, secure mounting for the PLC, preferably in a protective enclosure.
- **Wiring.** This includes properly installed incoming power to the power supply, as well as wiring from the I/O modules to field devices such as switches, sensors, solenoids, relays, etc.
- **Program.** An application program for the PLC to run. This is developed with GE Fanuc PLC programming software.

### What if the application requires more than five modules?

You could use a 10-slot baseplate, shown in the next picture:

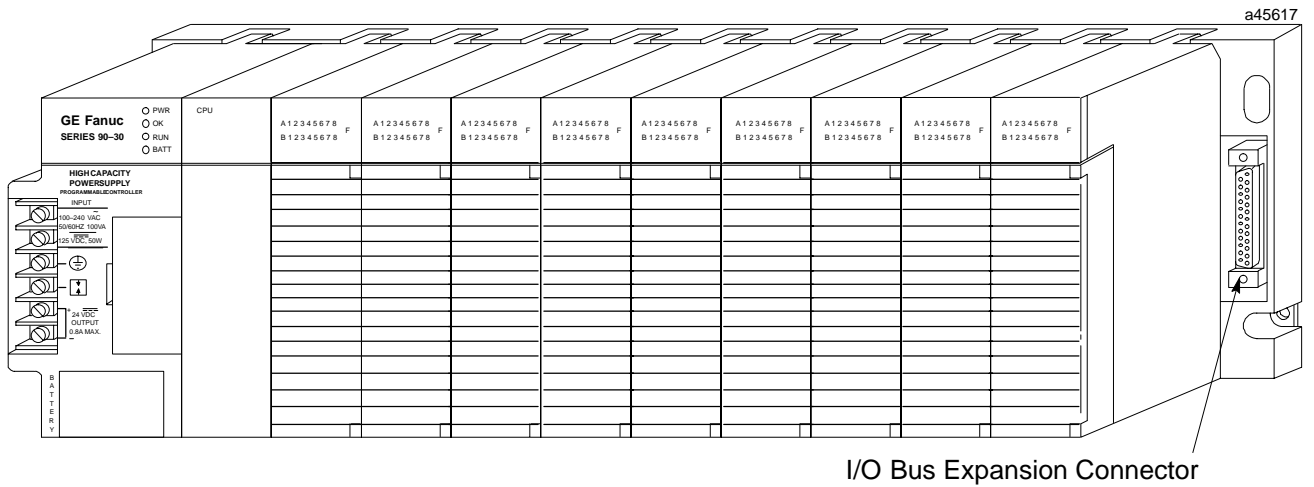

Figure 1-7. Ten-Slot Rack

### What if the application requires more than ten modules?

You can add one or more Expansion or Remote racks to this system. Some CPUs can support up to seven additional racks. If you added seven additional 10-slot racks, you could have 70 more modules.

Racks are interconnected in a "daisy-chain" cabling arrangement. This interconnection system is called the "I/O Expansion Bus." The connections are made from one baseplate's I/O Bus Expansion Connector (shown in the figure above) to the next one's. The I/O Bus Expansion Cables, shown below, have a double connector on one end to facilitate these connections.

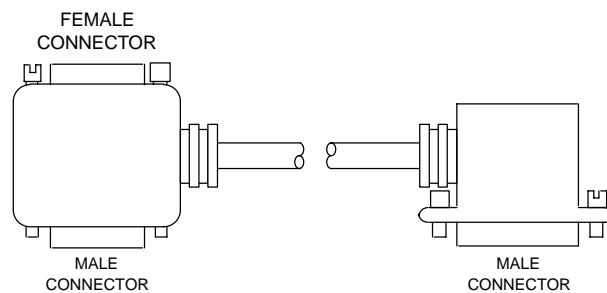

Figure 1-8. I/O Bus Expansion Cable

The next figure shows a system that has a CPU baseplate, one Expansion rack and three Remote racks. Notice that the last rack, the one at the end of the I/O Expansion Bus, must be terminated. A convenient way of terminating the bus is with an IC693ACC307 I/O Bus Terminator Plug, as shown.

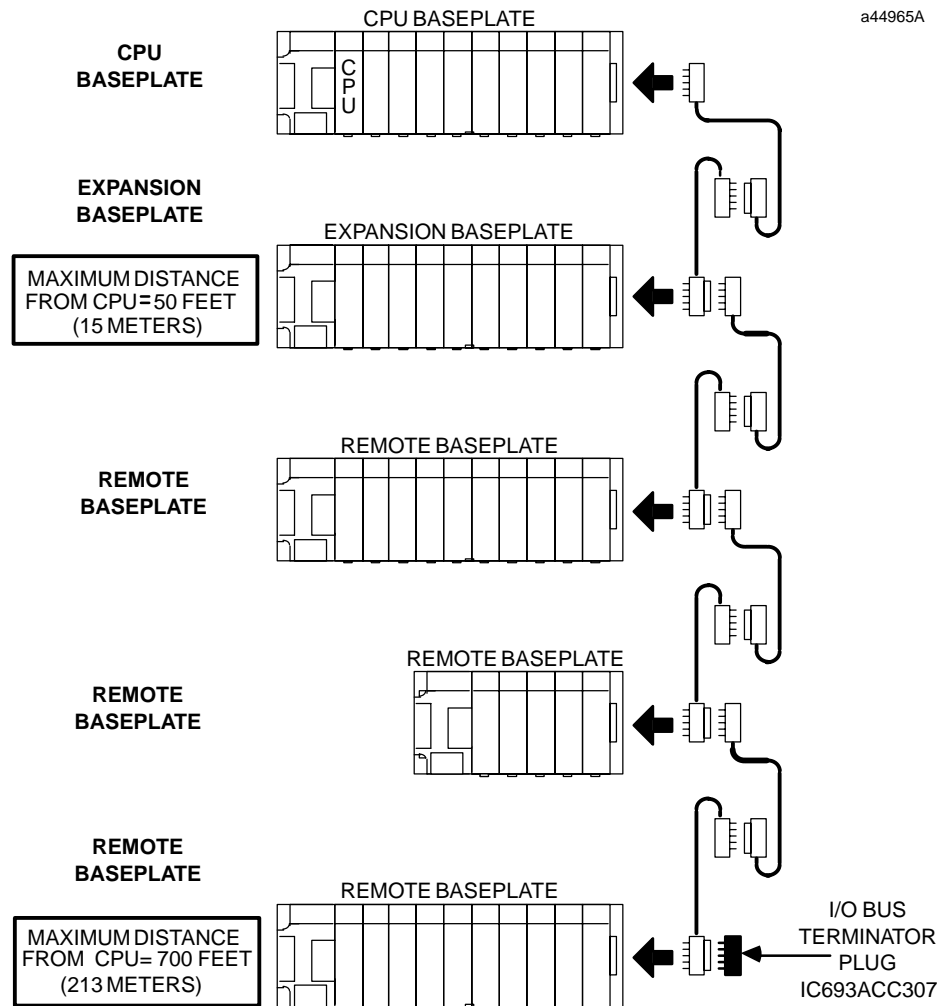

Figure 1-9. Connecting Expansion and Remote Baseplates

### What is the Difference Between Expansion and Remote baseplates?

The main factor to consider is distance. How far will the baseplate be from the CPU baseplate? If the cabling distance from the CPU baseplate is 50 feet (15 meters) or less, use an Expansion baseplate. The Expansion baseplate is preferable because of its higher communication speed with the CPU baseplate. However, if a baseplate must be located where it requires a cabling distance from the CPU rack in excess of 50 feet, an Expansion baseplate will not work – a Remote baseplate must be used. The limit for a Remote baseplate is a cabling distance of 700 feet (213 meters) from the CPU baseplate to the farthest Remote baseplate.

## What if I need to cover more than 700 feet (213 meters) ?

You can cover much greater distances by using Series 90-30 communications option modules. For example, Genius Bus Controller Modules (GBC) can communicate at distances up to 7,500 feet (2,286 meters) over a shielded twisted-pair cable, as shown in Example 1 below. Or, serial communications with Communications Coprocessor Modules (CMM) using the RS-485 standard can cover up to 4,000 feet (1,219 meters), as shown in Example 2 below. And virtually unlimited communication distances can be attained with modems and telephone lines or radio transmitters. Also, there are numerous networking options available such as Ethernet or WorldFIP.

### Example 1 – GBC

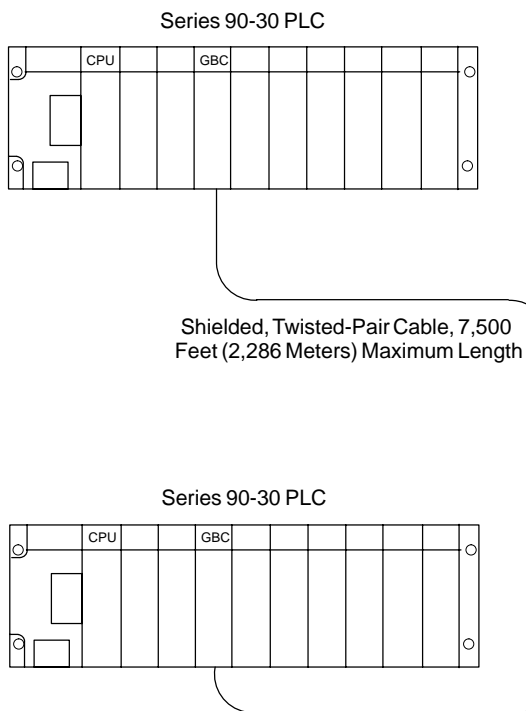

### Example 2 – CMM

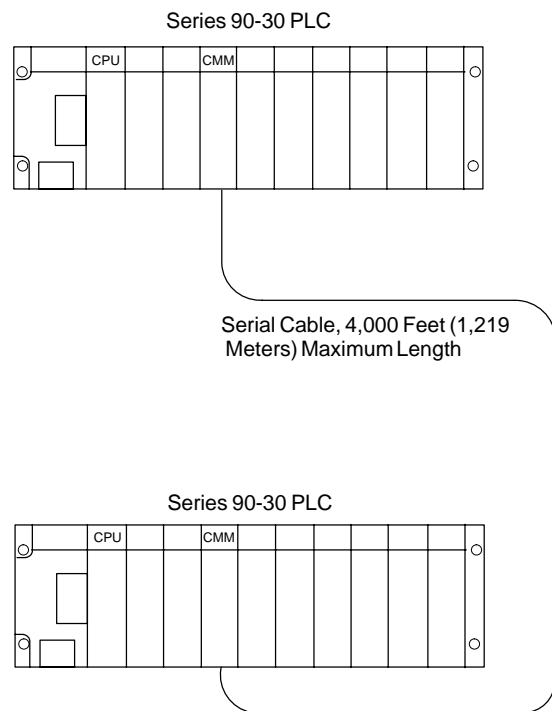

Figure 1-10. Connecting PLCs Using GBC or CMM Modules

# Chapter 2

## Installation

[efesotomasyon.com](http://efesotomasyon.com)

---

---

This chapter discusses installation details only. Other information about the products such as hardware descriptions and specifications, are covered in the applicable chapter.

### - Important Note -

*The installation instructions described in this chapter apply to PLC installations that do not require special procedures for noisy or hazardous environments. For installations that must conform to more stringent requirements (such as CE Mark), see **GFK-1179, Installation Requirements for Conformance to Standards**. Also see **GFK-0867, GE Fanuc Product Agency Approvals, Standards, General Specifications**.*

### Receiving your Products – Visual Inspection

When you receive your Series 90-30 PLC system, carefully inspect all shipping containers for damage that may have occurred during shipping. If any part of the system is damaged, notify the carrier immediately. The damaged shipping container should be saved as evidence for inspection by the carrier.

As the consignee, it is your responsibility to register a claim with the carrier for damage that happened during shipment. However, GE Fanuc will fully cooperate with you if such action is necessary.

### Pre-installation Check

After unpacking Series 90-30 PLC racks, cables, modules, etc., **record all serial numbers**. Serial numbers are printed on the module packaging. Serial numbers are required to make a claim during the warranty period of the equipment. All software product registration cards should be completed and returned to GE Fanuc. See the “Module Features” section in this chapter for location of module serial numbers. See the “Common Baseplate Features” section in the “Baseplates” chapter for location of baseplate serial numbers.

You should verify that all components of the system have been received and that they agree with your order. If the parts received do not agree with your order, call Programmable Control Customer Service, toll free, in Charlottesville, VA at 1-800-432-7521. A Customer Service representative will provide further instructions.

If you require assistance with your installation, the GE Fanuc *Technical Service Hotline* personnel in Charlottesville, VA are available to help you. North American customers should call toll-free at *1-800-GE FANUC (1-800-433-2682)*. International customers should dial direct: *804-978-6036*. The GE Fanuc web site support address is [www.gefanuc.com/support/plc](http://www.gefanuc.com/support/plc) Chapter 13, “Maintenance and Troubleshooting” has additional telephone numbers and troubleshooting information.

### Warranty Claims

Record the serial number of the defective item and contact your distributor for instructions.

## Working with Series 90-30 Modules

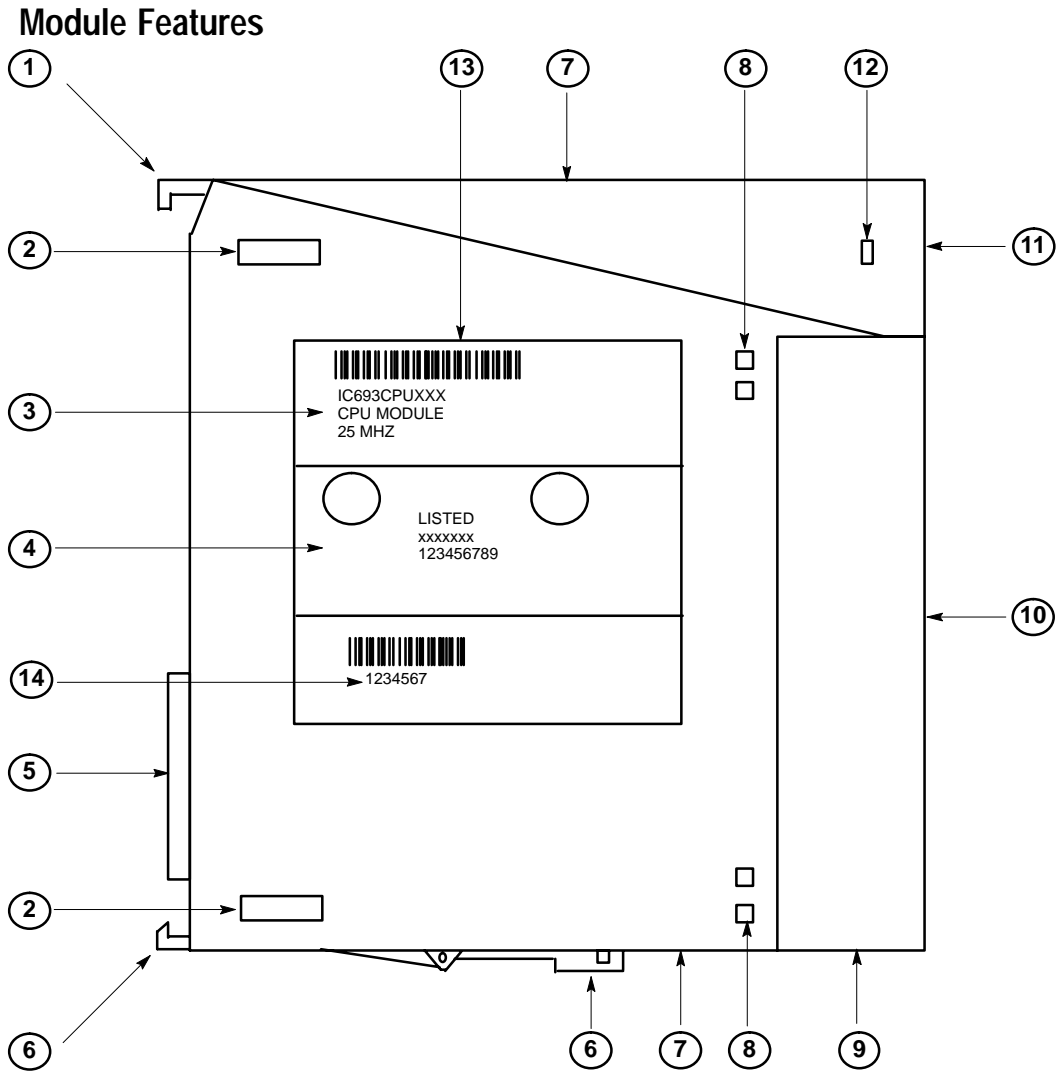

**Figure 2-1. Features of Series 90-30 Module**

1. Pivot hook
2. Circuit board holding tabs (two on each side of module)
3. Catalog number and description section of label
4. Certification (UL, CE, etc.) section of label
5. Module connector – plugs into baseplate backplane connector
6. Release lever – spring loaded
7. Ventilation openings in module case (top and bottom)
8. Front cover holding tabs (two on each side of module)
9. Front cover (shown) or terminal board (for I/O modules).
10. Front cover faceplate or hinged cover for terminal board.
11. Lens cap (some modules do not have).
12. Lens cap holding tabs (one on each side of module)
13. Module label
14. Serial Number – used to determine module warranty status. Note that on some modules, the Serial Number may be on a small tag on the back of the module.

## Installing a Module

### Warning

**Do not insert or remove modules with power applied. This could cause the PLC to stop or malfunction. Injury to personnel and damage to the module or baseplate may result. Also, attempts to force a module into an improper slot type will result in damage to the module and/or the baseplate. Modules will mount in the correct slot type easily, with a minimum of force.**

Use the following instructions as a guide when inserting a module into a baseplate slot.

- Check that module catalog number matches slot configuration. Each slot is, or will be, assigned a particular module type during configuration. A Power Supply module must be installed in the left end unnumbered slot only, and a CPU module and some special Option modules can only be installed in Slot 1 of a CPU baseplate. I/O Modules and most Option modules install in slots numbered 2 and higher.
- Grasp the module firmly with terminal board toward you and with rear pivot hook facing away from you.
- Align the module with the desired baseplate slot and connector. Tilt the module upwards so that top rear pivot hook of the module engages the baseplate's top module retainer.
- Swing the module downward until the module's connector engages the baseplate's backplane connector, and the release lever on the bottom of the module snaps into place in the baseplate's bottom module retainer.
- Visually inspect the module to be sure that it is properly seated.

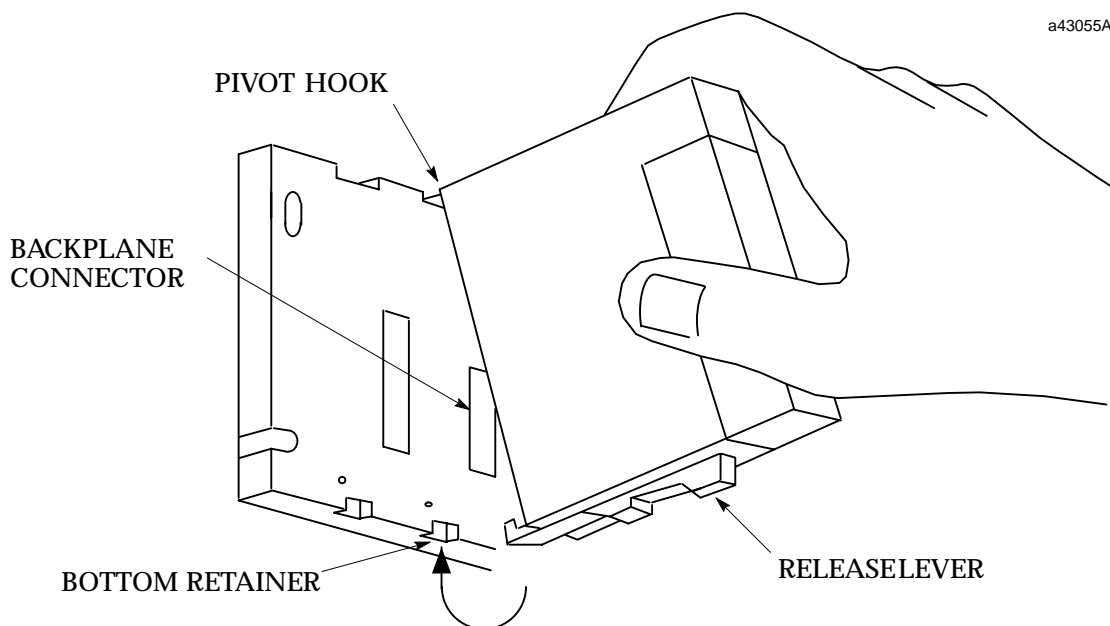

Figure 2-2. Installing a Module

## Removing a Module

### Warning

**Do not insert or remove modules with power applied. This could cause the PLC to stop or malfunction. Injury to personnel and damage to the module or baseplate may result. Also potentially dangerous voltages from user devices may be present on a module's screw terminals even though power to the rack is turned off. Care must be taken any time that you are handling the module's removable terminal board or any wires connected to it.**

- If the module has wiring, remove the module's terminal board (NOTE: You do not have to unwire the terminal board) or cables. The procedure for removing a terminal board is described later in this section.
- Locate the release lever at the bottom of the module and firmly press it up, towards the module.
- While holding the module firmly at its top and fully depressing release lever, swing (pivot) the module upward (release lever must be free of its retaining slot).
- Disengage pivot hook at the top rear of the module by moving the module up and away from the baseplate.

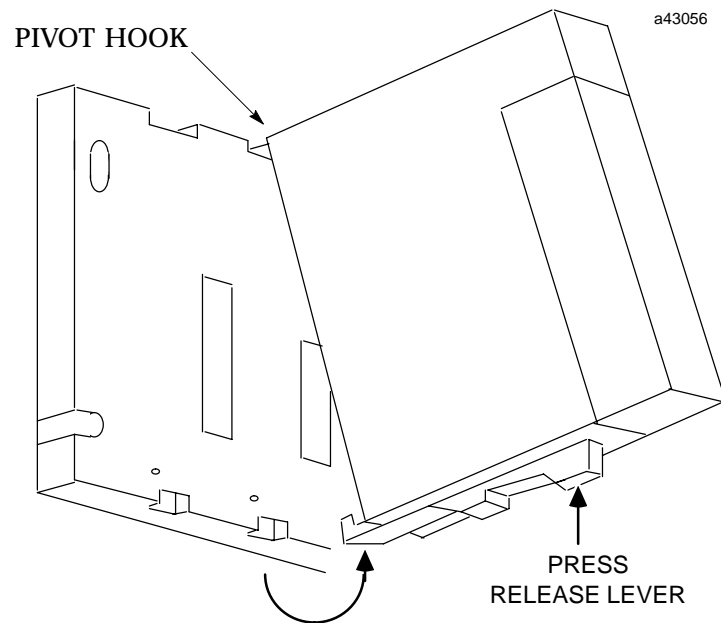

Figure 2-3. Removing a Module

### Note

Modules in expansion or remote baseplates can be added, removed, or replaced while the PLC is in RUN mode if power is first removed from the expansion or remote baseplate. I/O data to/from this baseplate will not be updated while power is removed.

## Installing a Module's Terminal Board

Note: Modules IC693MDL730F (and later) and IC693MDL731F (and later) have special terminal boards that are equipped with holding screws. For Installation and Removal instructions, please see the section “Installing and Removing Terminal Boards with Holding Screws” later in this chapter.

To install a terminal board:

- Hook the pivot hook①, located on the bottom of the terminal board, to the lower slot on the module.
- Push the terminal board towards the module② until it snaps into place.
- Open the terminal board cover③ and ensure that the latch on the module is securely holding the terminal board in place.

### Caution

Compare the module catalog number on the label on the back of the hinged door (see Figure 2-6) and the label on the side of the module (see below) to ensure that they match. If a wired terminal board is installed on the wrong module type, damage to the module may occur when the system is powered up.

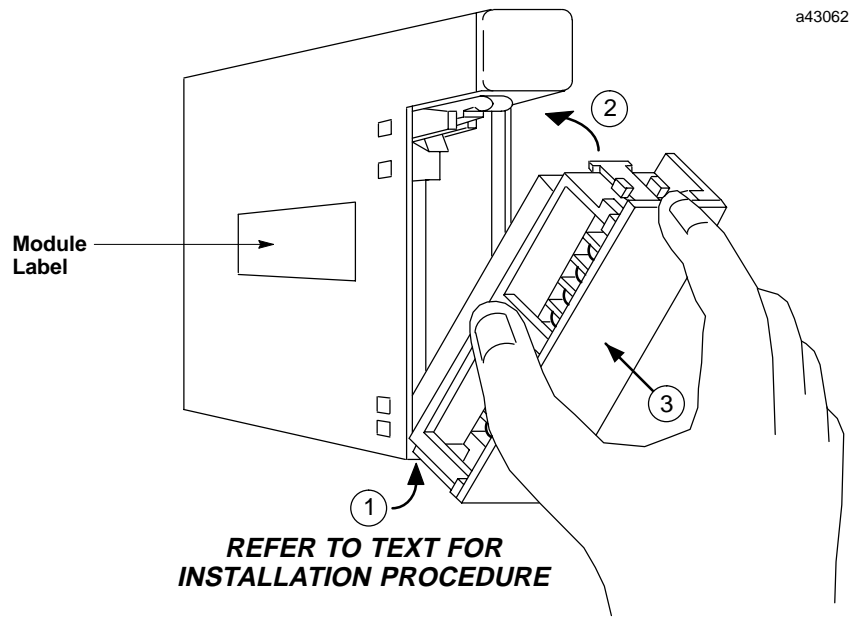
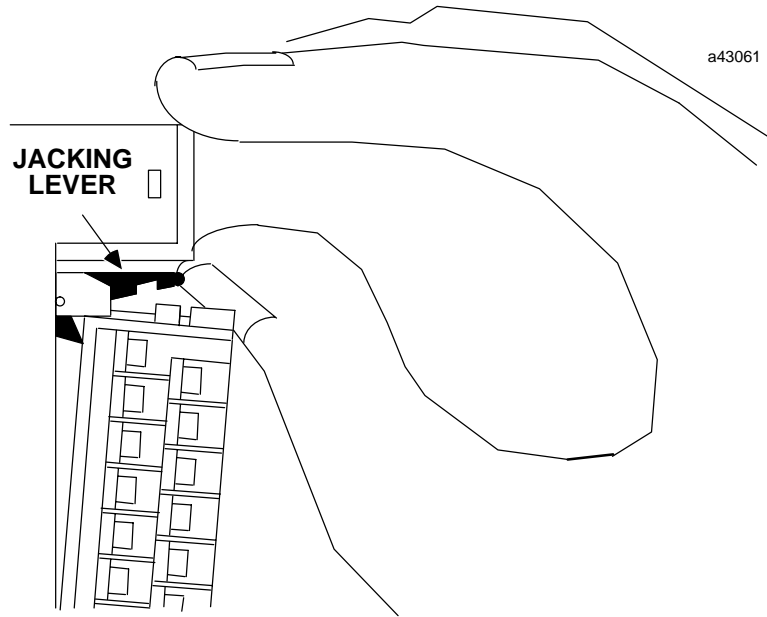

Figure 2-4. Installing an I/O Module's Terminal Board

## Removing a Module's Terminal Board

To remove a terminal board:

- Open the plastic terminal board cover.
- Push up on the jacking lever to release the terminal block.



- Grasp pull-tab and pull it towards you until contacts have separated from module housing and bottom pivot hook has disengaged.

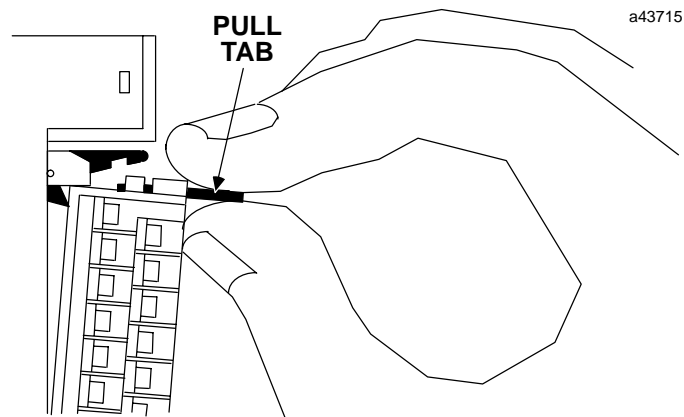

Figure 2-5. Removing a Module's Terminal Board

## I/O Module Terminal Board Posts

Notice that the terminal board has three posts on the left side. The top and bottom posts hold the terminal board cover in place. The purpose of the middle post is to keep the terminal board wiring in place. This middle post can be easily snapped off if you do not require it to hold the wiring in place.

Since minimal force is required to snap off the middle post, you should be careful that you do not inadvertently snap it off if you are using it to keep your wiring in place.

## Installing and Removing Terminal Boards with Holding Screws

Discrete output modules IC693MDL730F (and later) and IC693MDL731F (and later) have a special terminal board that is equipped with holding screws, shown in the figure below. These screws prevent the terminal board-to-module connections from deteriorating in applications where the PLC is subjected to severe vibration.

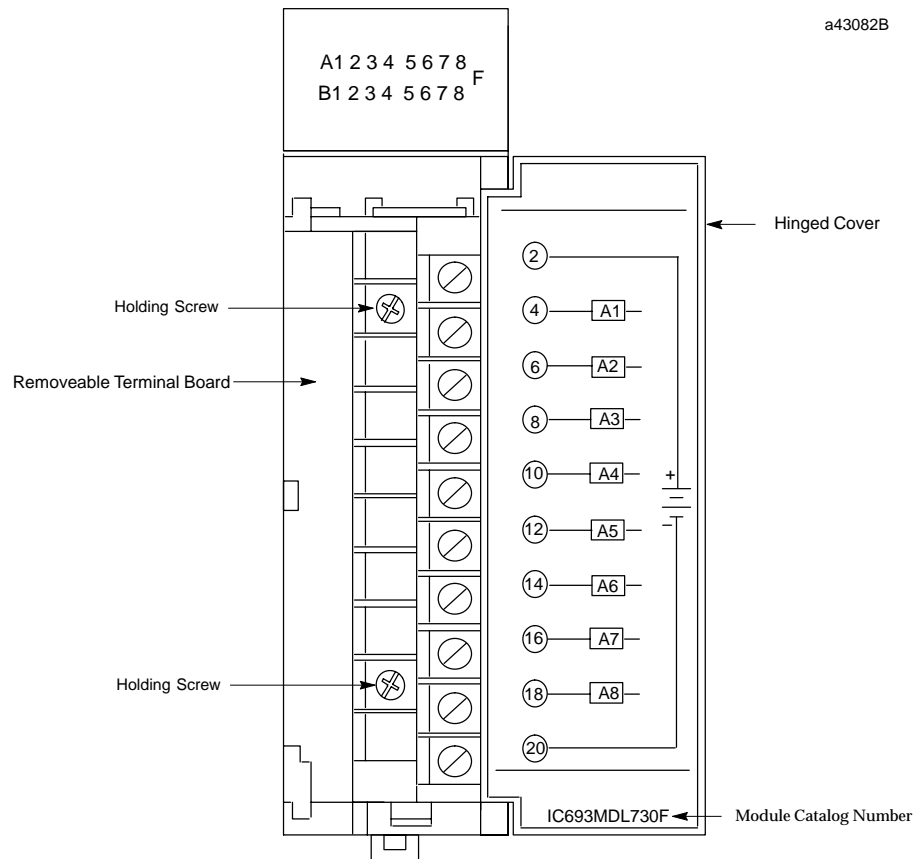

Figure 2-6. Terminal Board with Holding Screws

- **Removing:** To Remove these terminal boards, first loosen the two holding screws on the front of the terminal board, then follow the standard removal instructions in the section “Removing an I/O Module’s Terminal Board.” The holding screws are held captive in the terminal board and do not have to be completely removed.
- **Installing:** To install these terminal boards, follow the standard installation instructions in the section “Installing an I/O Module’s Terminal Board,” then tighten the two holding screws to 8 to 10 inch pounds (1 Newton-meter) of torque.

## Baseplate Mounting

### Warning

**Be sure to follow baseplate grounding instructions in this chapter. Failure to properly ground the PLC can result in improper operation, damage to equipment, and injury to personnel.**

### Mounting a Baseplate to a Panel

- Use four good-quality 8-32 x 1/2 (4 x 12 mm) machine screws, lock washers and flat washers. Install the screws in four 8-32 tapped holes. The “Baseplates” chapter has the applicable dimensions and mounting clearances. Alternately, 10-slot baseplates can be mounted in standard 19-inch racks by using the appropriate adapter. This is also discussed in the “Baseplates” chapter.
- A vertical mounting orientation is preferred for maximum heat dissipation. Other mounting orientations will require derating the Power Supply current capabilities. See Chapter 12, “System Design,” for details.
- All baseplates must be grounded. The “Baseplate Safety Grounding” section of this chapter has details.
- The Rack Number Selection switch must be set on each Expansion or Remote baseplate. A CPU baseplate does not require this switch. Rack numbers should be assigned by the system designer. Failure to set the Rack Number Selection switches properly will result in system malfunction. See the “Baseplates” chapter for details on setting these switches.

### Mounting a Baseplate to a 19” Rack

Two optional Baseplate Adapter Brackets allow a 10-slot baseplate to be mounted in a 19 inch rack. Each baseplate installation requires only one of the adapter brackets.

- **IC693ACC308 Front Mount Adapter Bracket.** Used to mount a baseplate to the front face of a 19” rack. Install the adapter bracket by inserting the tabs at the top and bottom of the adapter bracket into the corresponding slots at the top and bottom of the plastic baseplate cover. **NOTE: Although the figure below shows the plastic baseplate cover removed, this is for illustration purposes only. It is not necessary to remove the cover to install the bracket.** With the bracket in place, insert and tighten the two screws (included with the bracket) through the back of the baseplate holes into the threaded holes in the bracket.
- **IC693ACC313 Recessed Mount Adapter Bracket.** Used to recess mount a baseplate inside a 19” rack. A baseplate mounts on the rear panel of this adapter bracket using four 8-32 (4 mm) screws, nuts, lockwashers and flat washers. The Adapter Bracket bolts through its four slotted holes to the face of the 19” rack using applicable hardware (lockwashers recommended).

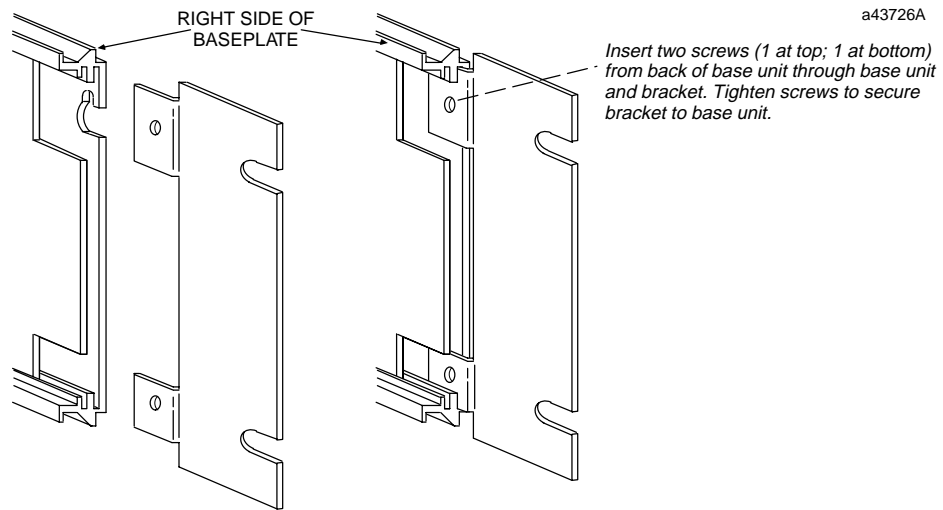

**Note:** Baseplate is shown with cover removed for illustration purposes. It is not necessary to remove the baseplate cover to install the bracket.

**Figure 2-7. IC693ACC308 Front Mount Adapter Bracket Installation**

Dimensions for rack mounting a 10-slot baseplate with the IC693ACC308 Front Mount Adapter Bracket are shown in the following figure.

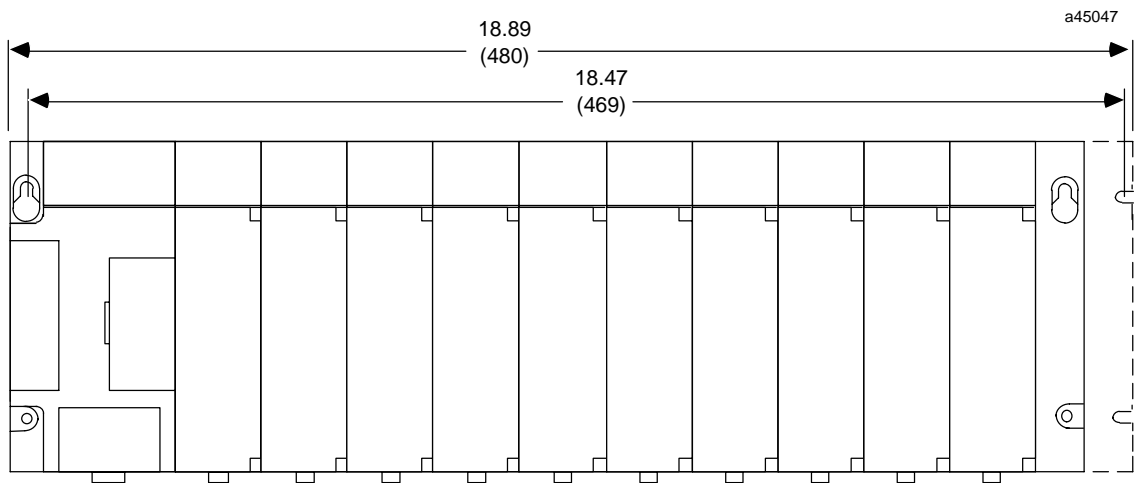

DIMENSIONS IN INCHES (MILLIMETERS IN PARENTHESES)

**Figure 2-8. Dimensions for 19" Rack Mounting Using IC693ACC308 Adapter Bracket**

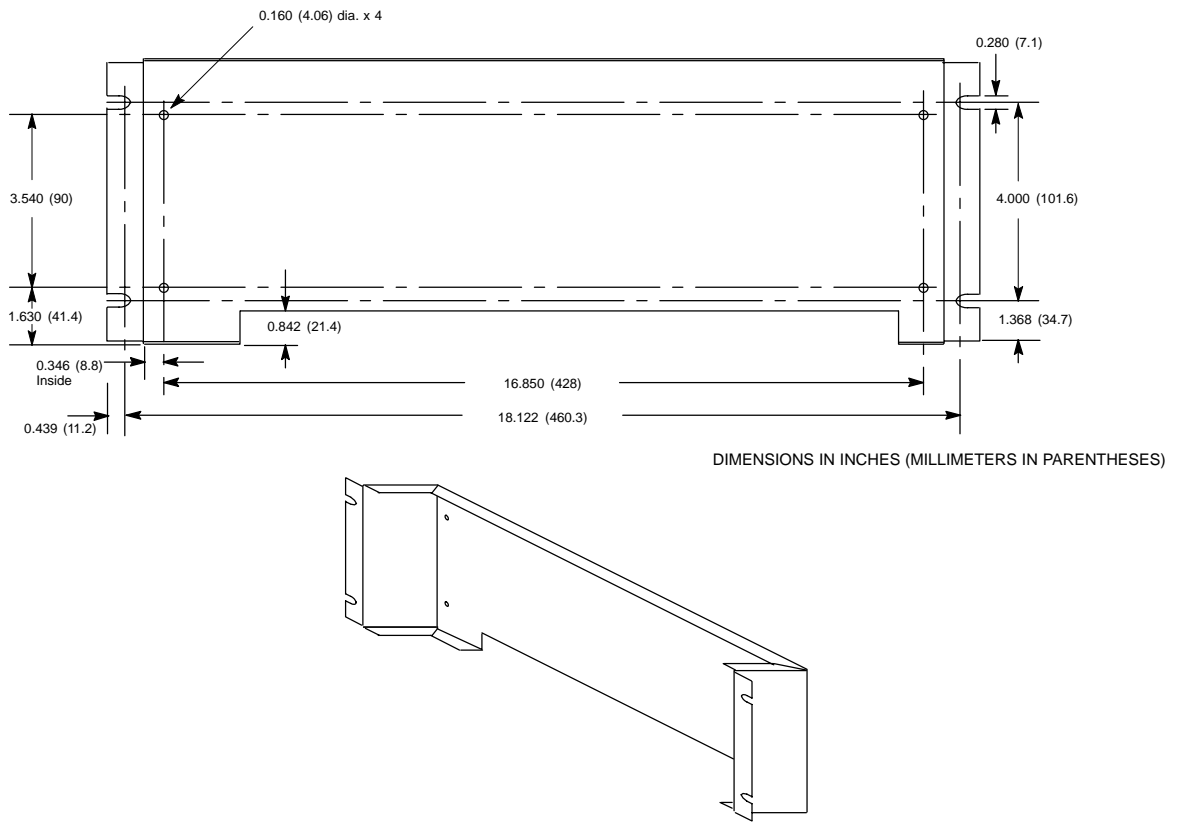

Figure 2-9. IC693ACC313 Recessed Mount Adapter Bracket

# Grounding Procedures

## System Grounding Procedures

### Warning

In addition to the following grounding information, we strongly urge that you follow all applicable codes that apply to your area. For example, in the United States, most areas have adopted the National Electrical Code standard and specify that all wiring conform to its requirements. In other countries, different codes will apply. For maximum safety to personnel and property you must follow these codes. Failure to do so can mean injury or death to personnel, damage to property, or both.

All components of a programmable logic control system and the devices it is controlling must be properly grounded. This is particularly important for the following reasons.

- A low resistance path from all parts of a system to earth minimizes exposure to shock in the event of short circuits or equipment malfunction.
- The Series 90-30 PLC system requires proper grounding for correct operation.

***The importance of a proper grounding cannot be over-emphasized.***

### Ground Conductors

- Ground conductors should be connected in a tree fashion with branches routed to a central earth ground point, shown in the figure below. This ensures that no ground conductor carries current from any other branch. This method is shown in the following figure.
- Ground conductors should be as short and as large in size as possible. Braided straps or ground cables (typically green insulation with a yellow tracer - AWG #12 (3.3 mm<sup>2</sup>) or larger) can be used to minimize resistance. Conductors must always be large enough to carry the maximum short circuit current of the path being considered.

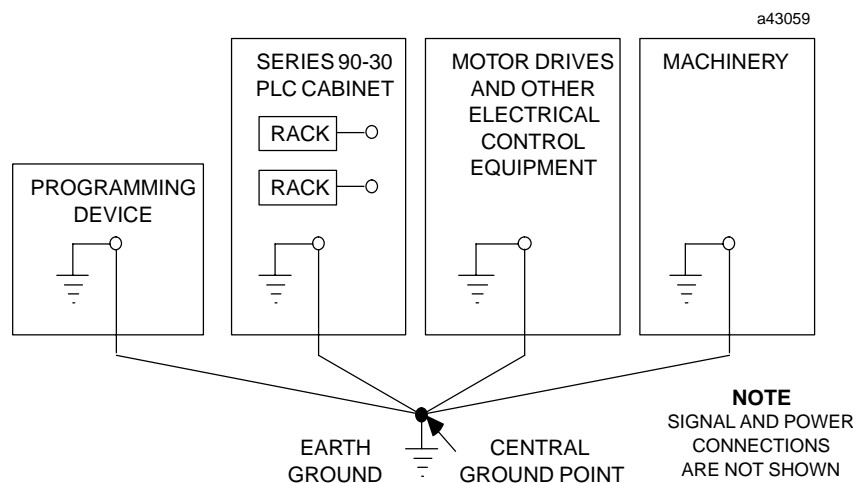

Figure 2-10. Recommended System Grounding

## Series 90-30 PLC Equipment Grounding

Equipment grounding recommendations and procedures are listed below. These grounding procedures must be properly followed for safe, proper operation of your Series 90-30 PLC system.

### Baseplate Safety Grounding

The following recommendations are offered, but applicable safety codes for your area or equipment type should also be consulted. The baseplate's metal back must be grounded using a separate conductor; the baseplate mounting screws are not considered to an acceptable ground connection by themselves. Use a minimum AWG #12 (3.3 mm<sup>2</sup>) wire with a ring terminal and star lock washer under the head of one of the baseplate's two lower mounting holes. These two holes have openings to the side to allow connecting a wire and ring terminal under the head of a mounting screw. Connect the other end of this ground wire to a tapped hole in the panel that the baseplate is mounted to, using a machine screw, star lock washer, and flat washer. Alternately, if your panel has a ground stud, it is recommended you use a nut and star lock washer for each wire on the ground stud to ensure adequate grounding. Where connections are made to a painted panel, the paint should be removed so clean, bare metal is exposed at the connection point. Terminals and hardware used should be rated to work with the aluminum baseplate material.

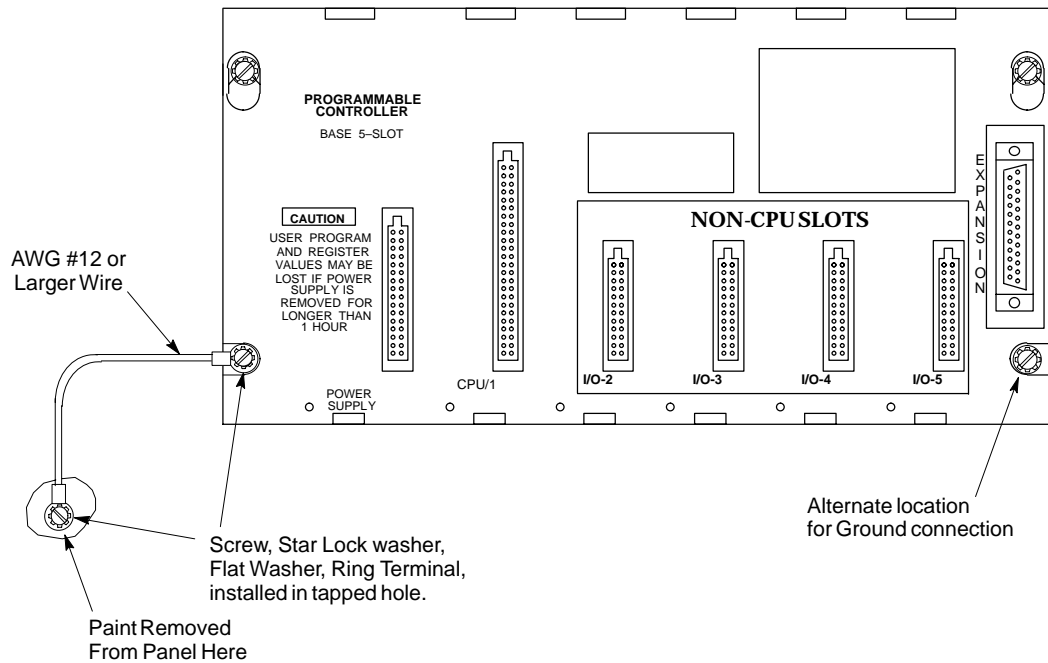

Figure 2-11. Baseplate Grounding

**Warning**

**All baseplates must be grounded to minimize electrical shock hazard. Failure to do so can result in severe personal injury.**

All baseplates grouped together in a Series 90-30 PLC system must have a common ground connection. This is especially important for baseplates that are not mounted in the same control cabinet.

## Grounding 19" Rack-Mounted Baseplates

There are two Adapter Brackets used for mounting a 10-slot Series 90-30 baseplate to a 19" Rack. Regardless of which of the two Adapter Brackets is used, the 19" Rack should be grounded as per the instructions in "System Grounding Procedures," including Figure 2-10. (For details on the Adapter Brackets, see the "Mounting a Baseplate to a 19" Rack" section earlier in this chapter.)

Nineteen-Inch Rack-mounted PLC baseplates should be grounded according to the guidelines in the "Baseplate Safety Grounding" section, using a separate ground wire from the PLC baseplate as shown in the previous figure (Fig. 2-11).

- If using the **Recessed Mount Adapter Bracket (IC693ACC313)**, the ground wire can be installed as shown in Figure 2-11 with the ground attached to the Recessed Mount Adapter Bracket. An additional ground wire connecting the Adapter Bracket to a solid chassis ground on the 19" Rack should be installed. Use the same or equivalent hardware and paint removal scheme as shown in Figure 2-11.
- If using the **Surface Mount Adapter Bracket (IC693ACC308)**, the ground wire should be run from the baseplate as shown in Figure 2-11, to a solid chassis ground on the 19" Rack. Use the same or equivalent hardware and paint removal scheme as shown in Figure 2-11.

## Programmer Grounding

For proper operation, the computer (programmer) running the PLC software must have a ground connection in common with the CPU baseplate. Normally, this common ground connection is provided by ensuring that the programmer's power cord is connected to the same power source (with the same ground reference point) as the baseplate. If it is not possible to ensure this common ground scheme, use a port isolator (IC690ACC903) between the programmer and PLC serial connection. If the programmer ground is at a different potential than the PLC ground, a shock hazard could exist. Also, damage to the ports or converter (if used) could occur when the programmer serial cable is connected between the two.

### Warning

**Failure to follow programmer grounding recommendations could result in personal injury, equipment damage, or both.**

## Module Shield Grounding

In general, the aluminum PLC baseplate is used for module shield grounding. On some Series 90-30 modules, shield connections to the user terminal connector on the module are routed to the baseplate through the module's backplane connector. Other modules, such as CPUs 351, 352, 363, and 364, require a separate shield ground. These are discussed in the next several sections.

### Shield Grounding Information for CPUs with External Port Connections

CPUs with external port connections, the 351, 352, 363, and 364, must have a separate shield ground connection which provides shielding for these ports. The design of the ground connection for the CPU351 and 352 is different from that of the CPU363 and 364, so each grounding method is discussed in a separate heading.

#### CPU351 and 352 Shield Grounding

The CPU 351 or 352 module must be connected to frame ground at the slot where it is installed. Two methods are provided for making this ground connection. Each CPU comes with an EMC Grounding Kit (44A737591-G01) that contains a ground wire, grounding bracket, and screws.

1. The connection from the CPU to frame ground can be made using the ground wire (part number 44A735970-001R01) that comes with the module in the EMC Grounding Kit. This wire has a stab-on connector on one end for connection to a mating terminal on the bottom of the CPU, and a ring terminal on the other end for connection to a grounded enclosure. Where the ring terminal contacts a painted enclosure panel, either a star lock washer can be installed between the terminal and the panel to cut through the paint, or the paint can be scraped away down to clean, bare metal to ensure a good contact. **Note: The star lock washer method is suitable for a shield ground, but not suitable for a safety ground.**

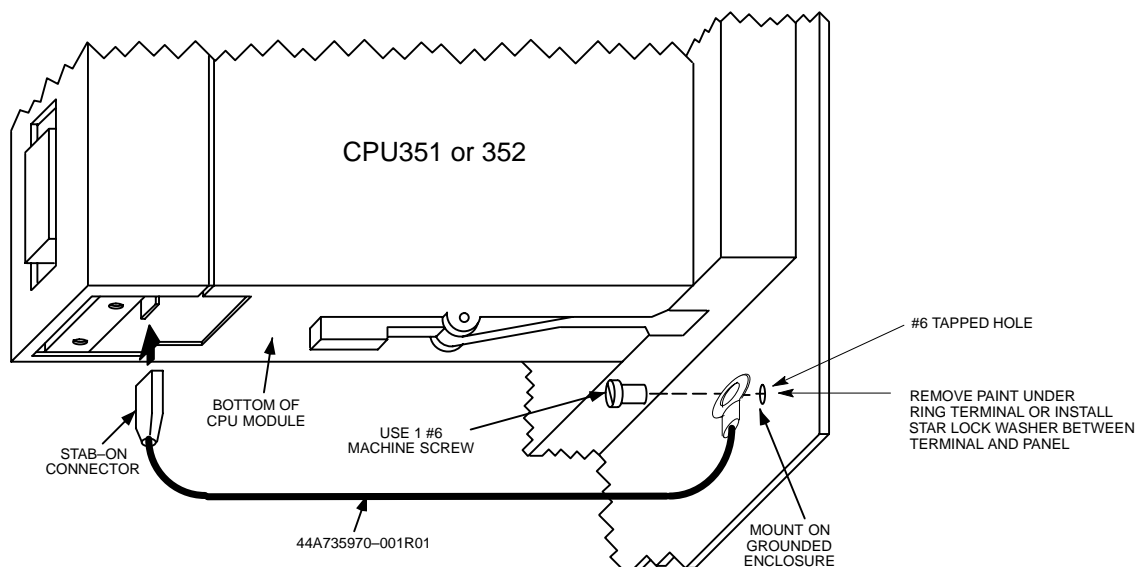

Figure 2-12. CPU 351 or 352 - Attaching Ground Wire

- The second method, which can be used for systems in noisy environments consists of installing the green ground wire **and** the optional grounding bracket (part number 44C715646-001R01). This bracket attaches to the CPU using two #4 thread-rolling screws (part number N666P9004B6) and to the grounded enclosure using two #6 thread-rolling screws (part number N666P13006B6). Two holes must be drilled in the enclosure for mounting this bracket. Also, if the bracket will be attached to a painted surface, the paint should be removed down to bare metal under the bracket to ensure good contact between the bracket and the surface. See the next figure.

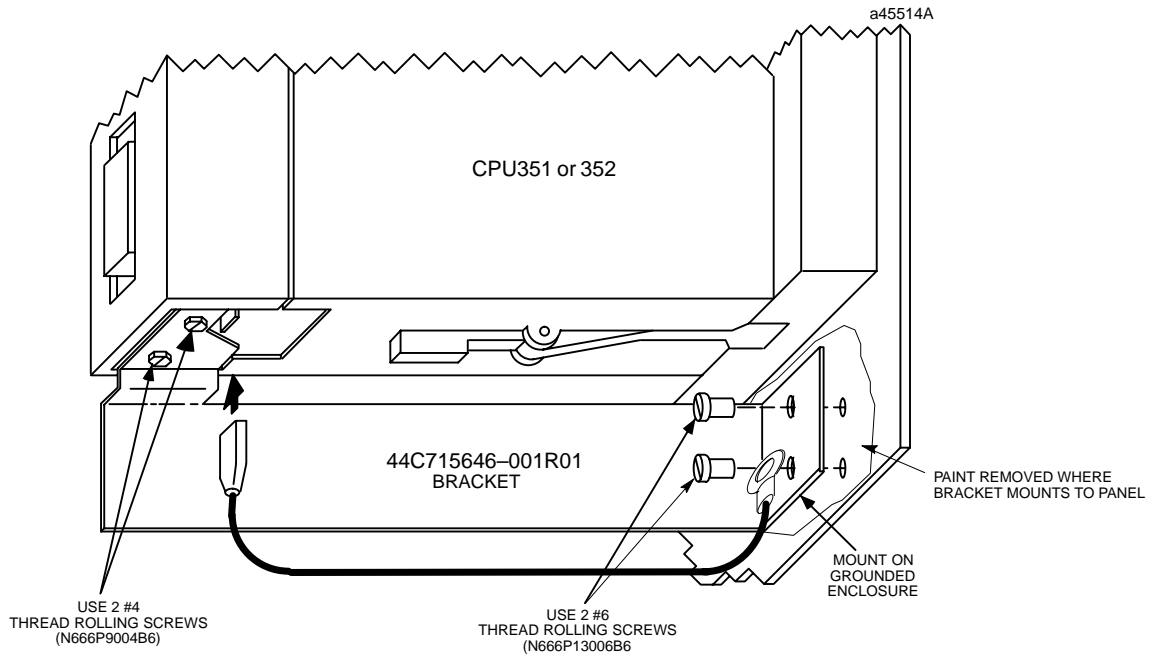

Figure 2-13. CPU 351 or 352 - Mounting Grounding Bracket

Note: When the grounding bracket is used, pin 1 of the cable connector that plugs into the Port 2 connector should not be connected. A metal connector shell must be used on the cable for this port, and the cable shield must be terminated at the metal shell instead of pin 1 of the connector.

### CPU363 and CPU364 Shield Grounding

The CPU363 and CPU364 modules must be connected to frame ground at the slot where they are installed. Each module comes with a grounding wire for this purpose. These modules do not support or require the use of a grounding bracket. If the ring terminal on the grounding wire is to be mounted to a painted surface, remove the paint under the ring terminal to ensure good contact, or place a star lock washer between the ring terminal and the painted surface. See the next figure. **Note: The star lock washer method is suitable for a shield ground, but not suitable for a safety ground.**

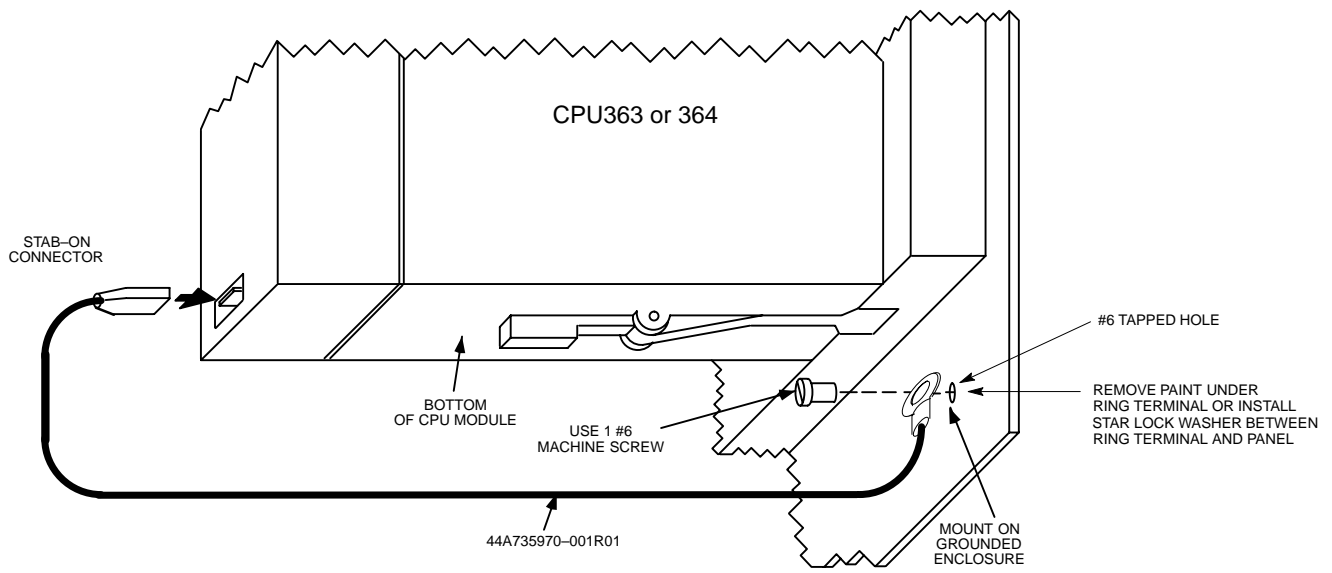

Figure 2-14. CPU 363 or CPU364 - Attaching Ground Wire

### Additional Modules with Shield Grounding Requirements

Some of the Series 90-30 Option modules, such as the FIP Remote I/O Scanner (IC693BEM330), and DSM modules (IC693DSM302 and IC693DSM314) also have shield grounding requirements. These modules come equipped with suitable grounding hardware. Please refer to each module's user's manual for grounding instructions. Appendix I contains a product to publication cross-reference to help you identify the correct manual.

## General Wiring Guidelines

### Warning

**In addition to the following wiring suggestions, we strongly urge that you follow all wiring and safety codes that apply to your area or your type of equipment. For example, in the United States, most areas have adopted the National Electrical Code standard and specify that all wiring conform to its requirements. In other countries, different codes will apply. For maximum safety to personnel and property you must follow these codes. Failure to do so can lead to personal injury or death, property damage or destruction, or both.**

### Color Coding Wires

These color codes are commonly used in industrial equipment manufactured in the United States. They are cited here as a reference. Where they are in conflict with codes that apply to your area or your type of equipment, you should follow your applicable codes instead. Besides satisfying code requirements, wire color coding makes testing and troubleshooting safer, faster, and easier.

- Green or green with stripe– Ground
- Black – Primary AC
- Red – Secondary AC
- Blue – DC
- White – Common or neutral
- Yellow – Secondary power source not controlled by the main disconnect. Alerts maintenance personnel that there may be power present (from an external source) even if the equipment is disconnected from its main power source.

### Wire Routing

To reduce noise coupling among PLC wires, it is recommended you keep electrically noisy wiring, such as AC power wiring and Discrete Output Module wiring, physically separated from low-level signal wiring such as DC and Analog Input module wiring or communications cables. This can be accomplished by grouping separately, where practical, the following categories of wiring:

- **AC power wiring.** This includes the AC input to the PLC power supply, as well as other AC devices in the control cabinet.
- **Analog Input or Output Module wiring.** This should be shielded to further reduce noise coupling. See the *Series 90-30 I/O Module Specifications Manual*, GFK-0898 for details.
- **Discrete Output Module wiring.** These often switch inductive loads that produce noise spikes when switched off.
- **DC Input Module wiring.** Although suppressed internally, these low-level inputs should be further protected against noise coupling by observing these wiring practices.

- **Communications Cables.** Wiring such as Genius Bus or serial cables should be kept away from noise-producing wiring.

Where AC or Output wiring bundles must pass near noise-sensitive signal wiring bundles, avoid running them beside each other. Route them so that, if they have to cross, they do so at a right angle. This will minimize coupling between them.

### Grouping Modules to Keep Wires Segregated

If practical, grouping similar modules together in the PLC racks can help keep wiring segregated. For example, one rack could contain only AC modules, and a different rack only DC modules, with further grouping in each rack by input and output types. For smaller systems, as an example, the left end of a rack could contain Analog modules, the middle could contain DC modules, and the right end could contain AC modules.

## Discrete I/O Module Connection Methods

- For modules with 16 points or less, the standard method is to use the removable terminal board which comes with these modules. The removable terminal board makes it easy to prewire field wiring to the user supplied input and output devices, and to replace modules in the field without disturbing existing field wiring.
- Some discrete 16-point I/O modules can be used with an optional Terminal Block Quick Connect (TBQC) assembly. This assembly contains a module faceplate, with built-in connector, that replaces the removable terminal board. The assembly also contains a DIN-rail mounted terminal block and a cable to connect the module to the terminal block. The advantage of this method is that it saves about two hours of wiring time per module compared with hand wiring from a module's removable terminal board to a user-supplied, panel-mounted terminal block or strip.
- Older 32-point I/O modules have one 50-pin connector on the front of the module that is either connected by a cable with a connector on each end to a Weidmuller panel-mounted terminal block (Weidmuller catalog no. 912263), or is connected by a cable with stripped, tinned leads to a user-supplied terminal block or strip.
- Newer 32-point I/O modules have two 24-pin connectors on the front of the module. These module may be wired in one of three ways. (1) Use a pair of cables (IC693CBL327/328 – see data sheet in “Cables” chapter) to connect the module to a user-supplied, panel-mounted terminal block or strip. These cables have a 24-pin connector on one end, and stripped, tinned leads with wire markers on the other end. (2) Use a pair of dual-connector cables to connect the module to a Terminal Block Quick Connect (TBQC) terminal block (IC693ACC377). See Appendix J for details. (3) Make your own custom cables. Instructions are found in the IC693CBL327/328 data sheet in Chapter 10.

## Connections to I/O Module Terminal Boards

Series 90-30 PLC I/O terminal boards have either 10 or 20 screw terminals that will accept from two AWG #22 (0.36 mm<sup>2</sup>) to two AWG #16 (1.3 mm<sup>2</sup>), or one AWG #14 (2.1 mm<sup>2</sup>) copper 90°C (194°F) wire(s). Each terminal can accept solid or stranded wires, but the wires into any given terminal should be the same type (both solid or both stranded)

to ensure a good connection. Wires are routed to and from the terminals out of the bottom of the terminal board cavity. The suggested torque for the I/O terminal board connection screws is from 9.6 in-lbs to 11.5 in-lbs (1.1 - 1.3 Newton-meters).

For 24 volt DC input modules, an internal 24 volt power connection is provided on the terminal board to supply a limited number of input devices. Also, a 24 volt DC output is available on the power supply module's terminal board to supply a limited number of output devices.

## Terminal Block Quick Connect Installation for 16-Point Discrete Modules

The Terminal Block Quick Connect (TBQC) Assembly is an option for certain Series 90-30 discrete I/O modules. See Appendix J for more information.

- Remove standard terminal board from module.
- Install TBQC faceplate (it has a 24-pin connector).
- Mount the TBQC terminal block. It has a 24-pin connector and a terminal strip, and mounts on a standard 35 mm DIN-rail.
- Connect a TBQC cable between the TBQC faceplate connector on the module and the connector on the TBQC terminal block.
- Wire I/O devices to the terminal block.

## Installation of 32-Point Discrete, 50-Pin Connector Modules

These 50-Pin modules are an older design and are not generally used on new systems, unless to fulfill standardization requirements. They are mainly used as replacements for existing installations. For new installations, we recommend the dual 24-pin connector style because they have additional features not found on the older modules (LED indicators, TBQC), and it is much easier to fabricate custom-length cables for them. Installation information is provided here for the convenience of those still using these modules.

### Using Weidmuller #912263 Terminal Block

Note: The TBQC is not available for these modules, but you may purchase a Weidmuller #912263 from your electronics distributor for this application.

- Mount the Weidmuller#912263 terminal block. It has a 50-pin connector and a terminal strip, and mounts on a standard 35 mm DIN-rail.
- Connect an IC693CBL306/307 cable between the module's faceplate connector and the connector on the Weidmuller terminal block. See Chapter 10 for cable data.
- Wire I/O devices to the terminal block. See the *Series 90-30 PLC I/O Module Specifications Manual*, GFK-0898, for pin-out information.

## Using Generic Terminal Block or Strip

- Mount terminal block/strip to the enclosure panel.
- Connect an IC693CBL308 or 309 cable, or a custom made cable, to the module's faceplate connector and wire the stripped ends of the cable to the terminal block/strip. See Chapter 10 for cable data.
- Wire I/O devices to the terminal block/strip.

## Direct Method

- Connect an IC693CBL308 or 309 cable, or a custom made cable, to the module's faceplate connector and wire the stripped ends of the cable directly to the field devices. See Chapter 10 for cable data. See the *Series 90-30 PLC I/O Module Specifications Manual*, GFK-0898, for pin-out information.

## Installation of Discrete 32-Point, Dual 24-Pin Connector Modules

### Using a TBQC

- Mount two TBQC terminal blocks. Each has a 24-pin connector and a terminal strip, and mounts on a standard 35 mm DIN-rail.
- Connect a pair of TBQC cables (IC693CBL329 – 334) between the module's faceplate connector and the connectors on the two TBQC terminal blocks. Note that both a right side and left side cable is required. See Appendix J for a list of cables.
- Wire I/O devices to the terminal blocks. See the *Series 90-30 PLC I/O Module Specifications Manual*, GFK-0898, for pin-out information.

The Terminal Block Quick Connect (TBQC) Assembly is an option for certain Series 90-30 discrete I/O modules. See Appendix J for more information.

### With a Generic Terminal Block/Strip

- Mount terminal block/strip to the enclosure panel.
- Connect an IC693CBL327/328 cables, or a custom made cables, to the module's faceplate connectors, and wire the stripped ends of the cables to the terminal block/strip. Note that both a right side and left side cable is required. See Appendix J for a list of cables. See Chapter 10 for cable data sheets.
- Wire I/O devices to the terminal block/strip. See the *Series 90-30 PLC I/O Module Specifications Manual*, GFK-0898, for pin-out information.

### Direct Method

- Connect an IC693CBL327/328 cables, or a custom made cables, to the module's faceplate connectors, and wire the stripped ends of the cable directly to the field devices. See Chapter 10 for cable data. See the *Series 90-30 PLC I/O Module Specifications Manual*, GFK-0898, for pin-out information.

## General Wiring Methods for Analog Modules

Twisted, shielded instrumentation cable is strongly recommended for analog module input or output signal connections. Proper grounding of the shield is also important. For maximum electrical noise suppression, the cable shield should only be grounded at one end of the cable. For Input modules, ground the end that is in the noisiest environment (which often is at the field device end). For Output modules, ground at the module end. See GFK-0898, *Series 90-30 PLC I/O Module Specifications*, for more shield grounding information.

## Analog Input Module Wiring Methods

Correcting electrical noise problems can sometimes be a trial-and-error routine. However, in general, it is generally best to ground the cable shield as close to the source of the noise as possible, which is usually at the device end. In troubleshooting noise problems, sometimes it is beneficial to experiment with the shield grounding point location. Remember, the cable shield should be grounded at one end only. Also, it is best to keep the length of stripped cable leads as short as possible to minimize the length of unshielded conductors that will be exposed to the noisy environment. See the *Series 90-30 PLC I/O Module Specifications Manual*, GFK-0898 for additional details.

### Using Generic Terminal Block or Strip

- Mount a terminal strip inside the control enclosure and run a shielded cable from the terminal strip to each input circuit on the module's terminal board terminals.
- Connect each cable's shield to the metal panel next to the terminal strip. Do not connect the shields at the module end (cut shield off at module end of cable and insulate with shrink tubing).
- Wire the field device to the terminal strip with a shielded cable, grounding the shield at the device end only (cut shield off at terminal strip end of cable and insulate with shrink tubing). Also, keep the length of exposed (outside of shield) leads at the terminal strip and device ends as short as possible.

### Direct Method

- Run a shielded cable from the field device (transducer, potentiometer, etc.) directly to the module.
- Connect the conductors to the applicable screws on the module's terminal board.
- Ground the shield at the field device end, exposing a minimum amount of conductor to the noisy environment. Do not connect the shield at the module end (cut shield off at module end of cable and insulate with shrink tubing).

### TBQC

The Terminal Block Quick Connect (TBQC) Assembly is not recommended for use with analog modules due to cable shielding requirements.

## Analog Output Module Wiring

### General

Each output should be connected using a good quality shielded wire with the cable shield grounded at the module end. See GFK-0898, *Series 90-30 PLC I/O Module Specifications*, for more information.

### Using Generic Terminal Block or Strip

- Mount a terminal strip inside the control enclosure and run a shielded cable from the terminal strip to each output circuit on the module's terminal board terminals.
- Ground each cable's shield at the module end only. Do not connect the shields at the terminal strip end (cut shields off at terminal strip end of cables and insulate with shrink tubing).
- Wire the field device to the terminal strip with shielded cables, grounding the shields at the terminal strip end only (cut shields off at field device end of cables and insulate with shrink tubing). Also, keep the length of exposed (outside of shield) leads at the terminal strip and device ends as short as possible.

### Direct Method

- Run a shielded cable from each field device (transducer, potentiometer, etc.) directly to the module.
- Connect the conductors to the applicable screws on the module's terminal board.
- Ground the shield at the module end only, exposing a minimum amount of conductor to the noisy environment. Do not connect the shield at the device end (cut shield off at device end of cable and insulate with shrink tubing).

### TBQC

The Terminal Block Quick Connect (TBQC) Assembly is not recommended for use with analog modules due to cable shielding requirements.

## AC Power Source Connections

### AC Input Wiring to AC/DC Power Supplies

#### Warning

**If the same AC power source is used to provide AC power to other baseplates in a Series 90-30 PLC System, ensure that all AC input connections are identical at each rack. Do not cross Line 1 (L1) and Line 2 (L2). A resulting difference in potential can injure personnel or cause damage to equipment. Each baseplate must be connected to a common ground.**

**Ensure that the protective cover is installed over all terminal boards. During normal operation with an AC power source either 120 VAC or 240 VAC is present on the AC Power Supply. The cover protects against accidental shock hazard which could cause severe or fatal injury to the operator or maintenance personnel.**

Both the Standard (IC693PWR321) and High Capacity (IC693PWR330) AC/DC power supplies currently have six terminals for user connections. Early versions of some Series 90-30 power supplies had five terminals (see next figure). The wiring methods for both five-terminal and six-terminal types is similar, except that step 3 below does not apply to the five-terminal type.

The power supply terminal boards will accept one AWG #14 (2.1 mm<sup>2</sup>) or two AWG #16 (1.3 mm<sup>2</sup>) copper 75° C (167° F) wires. Each terminal can accept solid or stranded wires, but the wires in any given terminal should be the same type. The suggested torque for the power supply terminal board is 12 in-lbs (1.36 Newton-meters). Open the door protecting the terminal board and make the following connections from the AC power source, and ground connections (system grounding requirements are described in detail later in this chapter).

1. These are wide range supplies that can operate from an AC power source within the nominal range of 100 VAC to 240 VAC at 50/60 Hz. This may vary -15% to +10% for a total maximum range of 85 VAC to 264 VAC. These are auto-ranging supplies that do not require jumper or switch settings for selection of power source voltage.
2. Connect the hot and neutral wires or lines L1 and L2 to the upper two terminals on the terminal board. Connect the safety ground wire to the ground terminal, which is the third terminal from the top, and is marked with a ground symbol.
3. For power supplies with six terminals, the factory jumper between the 3rd and 4th terminals (see figure below), should be left in place for normal installations. However, this jumper must be removed and external surge suppressors installed in installations with a "Floating Neutral" input. Please see the section "Special Instructions for Floating Neutral (IT) Systems" later in this chapter for details.
4. After all connections to Power Supply terminal board have been completed, the protective cover plate should be carefully reinstalled.

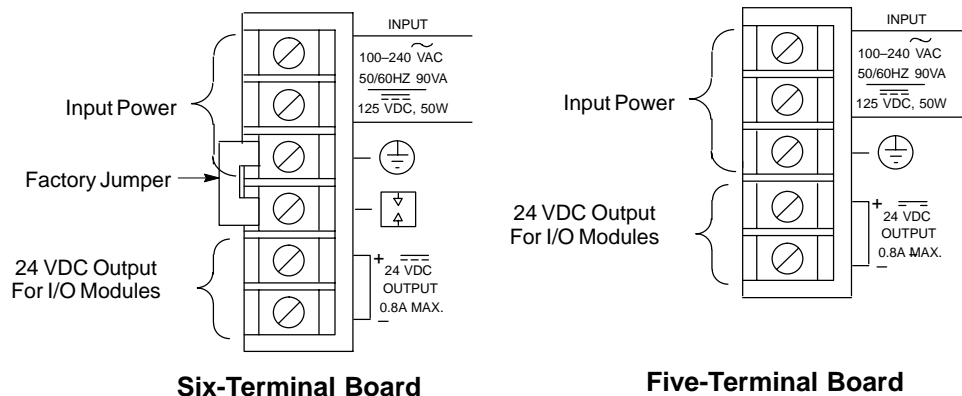

Figure 2-15. Power Supply Terminal Boards

### Power Supply Overvoltage Protection Devices

The overvoltage protection devices for this power supply are connected internally to pin 4 on the user terminal board. This pin is normally connected to frame ground (pin 3) with the supplied jumper strap which is installed at the factory. If overvoltage protection is not required *or* is supplied upstream, this feature can be disabled by leaving pin 4 unconnected by removing the jumper strap. Also, this jumper must be removed and external surge suppressors installed in installations with a “Floating Neutral” input, please see the following section “Special Instructions for Floating Neutral (IT) Systems” later in this chapter.

If you want to Hi-pot test this supply, overvoltage protection *must be disabled* during the test by removing the terminal board strap. Re-enable overvoltage protection after testing by reinstalling the strap.

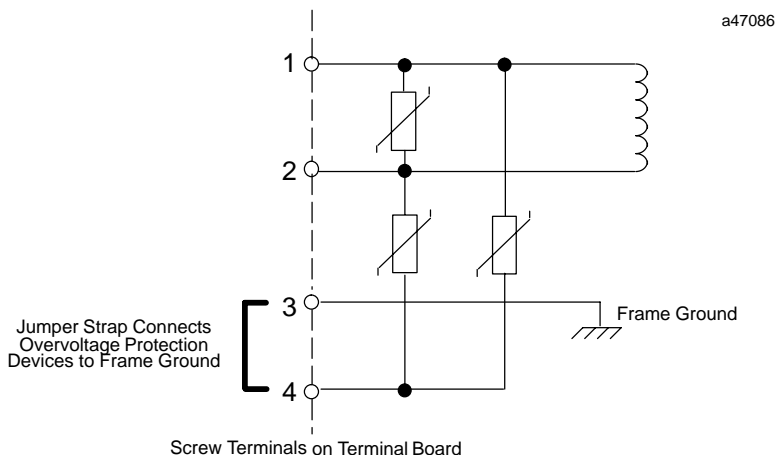

Figure 2-16. Overvoltage Protection Devices and Jumper Strap

# Special Installation Instructions for Floating Neutral (IT) Systems

When the AC input power supplies listed below are installed in a system where the Neutral line is **not** referenced to Protective Earth Ground, these special installation instructions must be followed to prevent damage to the power supply.

- IC693PWR321S (or later version)
- IC693PWR330A (or later version)

## Definition of Floating Neutral Systems

A *Floating Neutral System* is a system of power distribution wiring where Neutral and Protective Earth Ground are **not** tied together by a negligible impedance. In Europe this is referred to as an **IT** system (see IEC950). In a *Floating Neutral System*, voltages measured from input terminals to protective earth ground may exceed the 264 Volts AC maximum input voltage specified in the power supply specifications in Chapter 24 in this manual.

### Example of Floating Neutral System

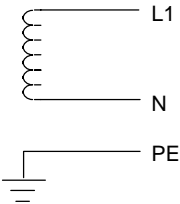

This system **must** be installed using the special installation instructions on the following page.

Systems in which one leg of the power distribution wiring is tied to Protective Earth or a tap between two legs of the power distribution wiring is tied to Protective Earth are **not** *Floating Neutral Systems*.

### Examples of Non-Floating Neutral System

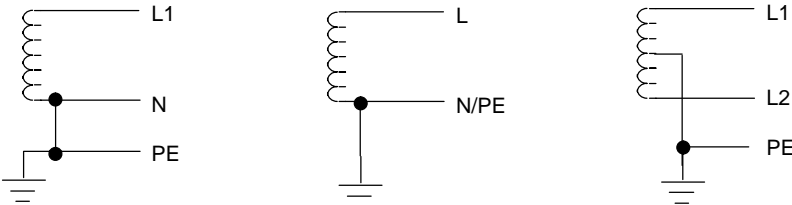

These non-floating neutral systems **do not** require these special installation instructions.

## Use These Special Installation Instructions for Floating Neutral Systems

1. The input power terminals should be wired according to the instructions in the “AC Power Source Connections” section of this chapter.
2. The factory installed jumper between terminals 3 and 4 of the Power Supply module **must** be removed if using one of the Power Supplies that have this feature. See the “Overvoltage Protection Devices” section of the “Power Supplies” chapter for details.
3. Voltage surge protection devices, such as MOVs, **MUST** be installed between the following terminals:
  - From L1 to earth ground
  - From L2 (Neutral) to earth ground

The voltage surge devices must be rated such that the system is protected from power line transients that exceed  $Line\ voltage + 100V + (N-PE)_{MAX}$ .

The expression  $N-PE$  refers to the voltage potential between neutral and Protective Earth (PE) ground.

For example, in a 240 Volt AC system with neutral floating 50V above earth ground, the transient protection should be rated at:

$$240V + 100V + 50V = 390V$$

---

## DC Power Source Connections

### DC Input Wiring to AC/DC and DC-Only Power Supplies

DC Input power can range from 12 to 30 VDC for the 24 VDC supply, 18 to 56 VDC for the 24/48 VDC supply or 100 to 150 VDC for the 125 VDC supply. All Series 90-30 power supplies have DC input capabilities. The following connection information applies to all of them:

Connect the + and - wires from the power source to the top terminals on the terminal board (+ to the top terminal, - to the second terminal). Connect the third terminal from the top to system ground.

### +24 VDC Output (All Supplies)

The bottom two terminals are connected to the isolated 24 volt DC output that can be used to supply power to input circuits (within power limitations of the supply).

### Warning

**If the same DC input power source is used to provide power to two or more power supplies in a Series 90-30 PLC System, ensure that connection polarity is identical at each rack (top terminal + and second terminal -). Do not cross the Positive (+) and Negative (-) lines. A resulting difference in potential can injure personnel or cause damage to equipment. Also, each baseplate must be connected to a common system ground, described earlier in this chapter.**

## Basic Installation Procedure

The system design, which includes producing the layout and wiring drawings, should be completed before beginning the installation procedure. This section offers a basic step-by-step approach to installing a Series 90-30 PLC system. Some steps refer to earlier sections of this chapter for additional details. An attempt was made to place the steps in an order that will make the process as efficient as possible. However, due to the wide variance in system designs, this order may not be the most efficient for your system, so you may wish modify this procedure to fit your needs.

1. Gather the schematics, layouts, prints, and other information for the job.

### Warning

**To avoid the possibility of electrical shock to personnel or damage to your PLC, we recommend that you shut off all power to the system before mounting and wiring the PLC. Also, keep all electronic components away from the area while drilling and tapping to keep metal chips and filings out of these sensitive components.**

2. From the layout drawing, determine where the baseplate(s) will be mounted. Lay out the hole locations, either using the dimensions given on your layout drawing or from the “Baseplates” chapter of this manual.
3. Mark the hole locations for the baseplate safety ground wire (see “Baseplate Safety Ground” in this chapter).
4. Mark the hole locations for module shield ground connections (if any). See “Module Shield Ground” (and accompanying sections) in this chapter for instructions.
5. Finish laying (marking hole locations) out the rest of the system. This includes any terminal blocks you will be using. DIN-rail mounted terminal blocks for some of the 32-point I/O modules are manufactured by Weidmuller. DIN-rail mounted GE Fanuc Terminal Block Quick Connect (TBQC) assemblies are optional for some of the 16-point and 32-point discrete I/O modules. If using these TBQCs, refer to Appendix J for data. Also, APM and DSM modules use DIN-rail mounted terminal blocks.

### Note

We recommend drilling and tapping all holes before mounting any components. This will avoid getting chips and filings in the components.

6. Drill and tap the marked holes. For baseplate mounting, use 8-32 or 4mm size.
7. Mount the baseplates. Use good quality 8-32 x 1/2 inch or 4 x 12mm size screws. We recommend using star lock washers and flat washers under the screw heads (star lock washer should be located between screw head and flat washer) to ensure a tight baseplate ground connection, and to keep the screws from loosening. Connect each baseplate ground wire as shown in the “Baseplate Safety Ground” section of this chapter.
8. If you have Expansion or Remote racks, determine the correct rack number for each one, then set the rack numbers using the Rack Number Selection DIP switch on the baseplate. Please refer to the “Baseplates” chapter for details on setting these DIP switches. Rack numbers should be assigned by the system programmer because they correspond to system configuration settings and program memory addressing.

9. If you have more than one baseplate (rack), connect the I/O Bus Expansion Cables between the I/O Bus Expansion Connectors, which are located on the right end of the baseplates. The cables are connected in a “daisy-chain” arrangement from one baseplate to the other. This is made possible by the fact that the cables have a dual connector on one end. Therefore, when the cable is plugged into a baseplate connector, the second connector on that end of the cable provides a socket for connecting to the next cable. The data sheet for the I/O Bus Expansion cables (IC693CBL300 etc.) in the “Cables” chapter has sample wiring figures.
10. On the last I/O Bus Expansion Connector, plug in an I/O Bus Expansion Terminator, Catalog Number IC693ACC307 (unless using a cable with built-in terminator resistors, which would either be GE Fanuc cable IC693CBL302, or your own custom-built cable).
11. Install the modules in their correct slots using your system layout drawings. (The label on the side of each module identifies the module type and catalog number.) Refer to the section “Installing Modules” if you are not familiar with how to do this.
12. Connect cables to Option modules. Route cables away from noise-producing wires. See the “Wire Routing” section of this chapter.
13. Be sure to follow the information in the “Wiring Guidelines” section of this chapter to protect the system from electrical noise. Install the power wires to the Power Supply and I/O modules:
  - **I/O modules with removeable terminal boards.** You can wire the terminal boards in-place on the modules or remove them from the modules before wiring. Although removing them may help make wiring easier (a previous section “Working with Removeable Terminal Boards” shows how to remove a terminal board), care should be taken to avoid mixing them (each terminal board has the catalog number of the module printed on it, and the hinged cover has a wiring diagram for that module type). If you are using wire duct, routing each module’s wires through the opening in the duct directly under the module will help to keep each terminal board in its correct position.
  - **I/O Modules with terminal blocks.** Some modules use terminal blocks that mount to the enclosure panel. This includes all 32-point modules and, can include other I/O modules if they are fitted with the optional Terminal Block Quick Connect Assembly. Connect the terminal blocks to the connectors on the modules with the provided cables.
14. Connect the signal (switches, sensors, solenoids, etc.) wires to the terminal boards, or terminal blocks/strips. If wiring to terminal boards, these can be removed for ease of wiring, if desired. See the section “Removing a Module’s Terminal Board.”
15. When finished wiring the I/O terminal boards (if used and if you removed them for ease of wiring), re-install them on the modules, being careful to match each one with the correct module.

# Chapter 3

## Baseplates

[efesotomasyon.com](http://efesotomasyon.com)

---

---

### Baseplate Types

A baseplate is composed of three main parts: (1) a circuit board mounted to (2) a metal back-plate with (3) a plastic cover. The circuit board, called the "backplane," contains sockets for plug-in modules. The metal back-plate has four holes for mounting the baseplate, and retainers for mounting the modules. The plastic cover provides protection for the circuit board, slotted holes for the module connectors and retainers, and printed labels such as the baseplate description, serial number, and slot number labels. There are three basic types of baseplates discussed in this chapter:

- CPU
- Expansion
- Remote

### Common Baseplate Features

The callouts in the following picture show the items that are common to all Series 90-30 baseplates. Note that a modular CPU baseplate is shown.

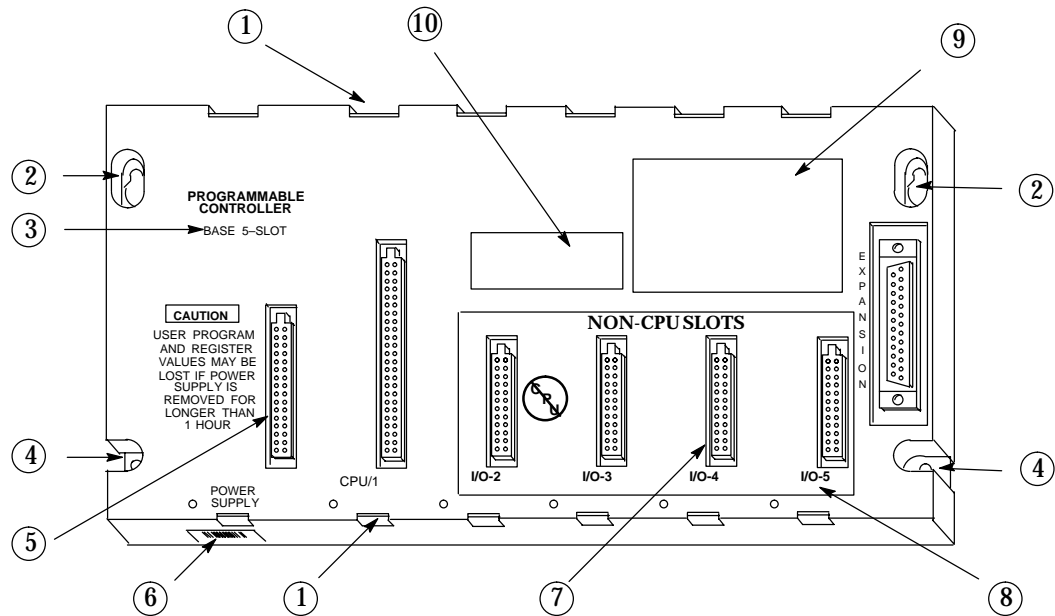

1. Module retainers
2. Upper mounting holes
3. Baseplate description
4. Lower mounting holes. The plastic cover is slotted at these two holes to facilitate a ground connection. See the “Baseplate Safety Grounding” section of the “Installation” chapter for ground connection details.
5. Backplane connector for Power Supply
6. Serial number label
7. Backplane connectors for I/O or Option modules (slots 2–4) . Note that the slot labeled CPU/1 is the backplane connector for a CPU module; however, on Embedded CPU, Expansion, and Remote baseplates, this would be another I/O or Option module slot.
8. Slot number labels
9. Compliance label
10. Catalog number and certification (UL, CE, etc.) label. On an Embedded CPU baseplate, this label will be located between Slots 4 and 5.

Figure 3-1. Common Baseplate Features

### Two Baseplate Sizes

Series 90-30 baseplates come in two sizes: 5-slot and 10-slot. Be aware that the Power Supply slot is not numbered, and is not considered to be one of the 5 or 10 slots. So a 5-slot baseplate has slots for a Power Supply and five other modules, and a 10-slot baseplate has slots for a Power Supply and ten other modules.

## Baseplate Terms Explained

**Backplane:** Refers to the circuit board in the baseplate. It contains the baseplate circuitry and sockets for the plug-in modules.

**Rack:** This term applies to an assembly consisting of a baseplate, power supply, and other modules.

**Rack Number:** In systems that require more than one rack, each rack is given its own unique number, which enables the CPU to distinguish one rack from another.

**Slot Number:** Each module location (called a "slot") on a baseplate has a unique number (except for the unnumbered left slot which is for the Power Supply). The slot to the right of the Power Supply slot is always called Slot 1. These slot numbers are marked on the baseplate's plastic cover. Each slot has a connector for module connections and top and bottom retainers for holding the module in place.

**Module Location:** Since each rack is assigned a unique number, and since each slot in a rack's baseplate has a unique slot number, each individual module's location in a system can be identified by its rack and slot numbers. For example, a module could be referred to as "the module in Rack 1, Slot 4." This numbering method enables the CPU to correctly read from and write to a particular module, and report the location of a faulted module.

**CPU Baseplate:** A baseplate that either has a CPU built-in to its backplane circuit board (embedded CPU) or one that has a slot for a plug-in CPU module (modular CPU). There can only be one CPU baseplate in a Series 90-30 PLC system and it will always be called Rack 0 (zero). A CPU module can only mount in Slot 1 of a CPU baseplate. A special Option module, such as the FIP Remote I/O Scanner module (IC693BEM330) can also be used in Slot 1 of a CPU baseplate. I/O, Power Supply, and most Option modules cannot fit in a CPU slot.

**Expansion Baseplate:** One that does not contain a CPU and which can be mounted up to 50 cable-feet from the CPU baseplate. An Expansion baseplate cannot operate on its own. It must be used in a system that has a controlling CPU.

**Remote Baseplate:** One that does not contain a CPU and which can be mounted up to 700 cable-feet from the CPU baseplate. A remote baseplate cannot operate on its own. It must be used in a system that has a controlling CPU.

**Power Supply Slot:** Each baseplate must contain its own Power Supply module, which must mount in the Power Supply slot. It is the slot located on the left end of the baseplate, it is not numbered, and it has a unique size and shape so that only a Power Supply module can mount in it.

### Note

**Attempts to force a module into an improper slot type will result in damage to the module and/or the baseplate. Modules will mount in the correct slot type easily and with a minimum of force.**

## CPU Baseplates

There are two basic kinds of CPU baseplates, embedded and modular. The embedded types fulfill the need for a good low cost PLC, but lack the power, expandability, and versatility of the modular systems.

**Embedded CPU Baseplate:** This type has CPU and memory integrated circuit chips soldered to its backplane circuit board.

**Modular CPU Baseplate:** This type does not have CPU and memory chips on its backplane. Instead, it has a connector in Slot 1 for a plug-in CPU module which contains the CPU and memory chips on an internal circuit board.

### Embedded CPU Baseplates (Figures 3-2 and 3-3)

There are three models of embedded baseplates, the 311, 313, and 323. These model numbers are based upon the CPU type that each contains. This chapter discusses only the baseplate features of these products. CPU specifications for the embedded CPU are located in Chapter 4. The embedded CPU baseplates have the following features:

- The CPU type cannot be changed.
- They do not support the use of expansion or remote racks, so these racks do not have an expansion connector like the modular CPU baseplates do.
- The models 311 and 313 are 5-slot baseplates, and the model 323 is a 10-slot baseplate.
- Since they do not require a plug-in CPU module, all numbered slots, including Slot 1, can be used for I/O or Option modules.
- The memory back-up battery is located in the Power Supply module; so if the Power Supply is unplugged from the baseplate, the battery will be disconnected from the memory circuits, which are located on the backplane circuit board. However, the backplane circuit board contains a high value capacitor, sometimes called a "super capacitor," that can store enough charge to maintain the memory circuits for about 1 hour if the Power Supply is removed or its battery is disconnected. Chapter 6 discusses the IC693ACC315 Battery Accessory kit that can be used to maintain memory contents when the Power Supply is removed from an embedded CPU baseplate.
- There are no configuration switches or jumpers on the Model 311, 313, or 323 baseplates.
- An embedded CPU baseplate is always assigned, by default, Rack Number Zero (0).

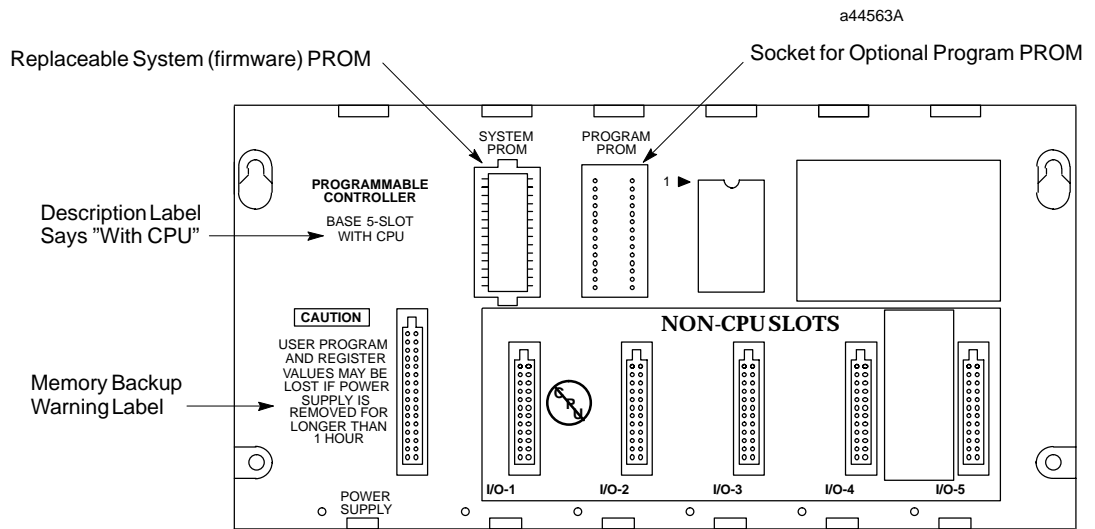

Figure 3-2. Models IC693CPU311 and IC693CPU313 (5-Slot) Embedded CPU Baseplates

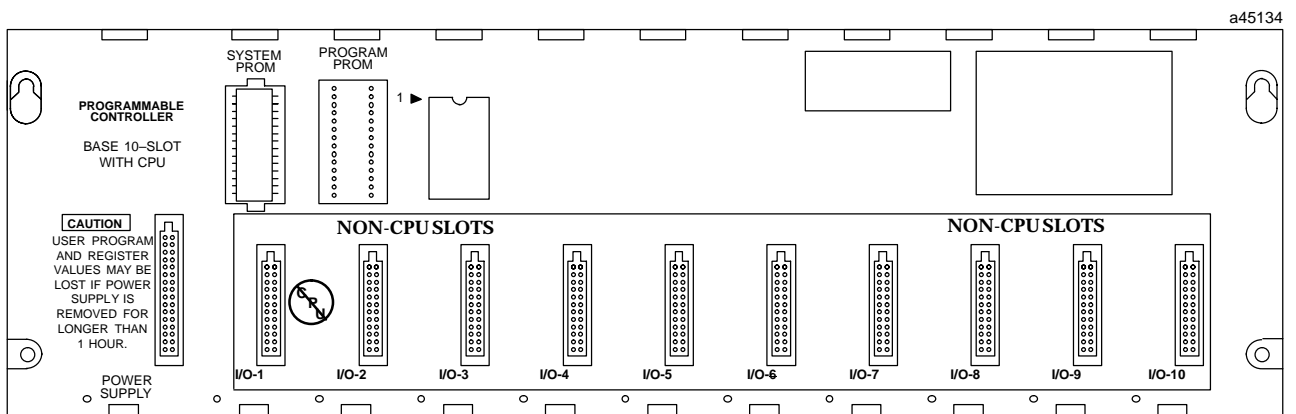

Figure 3-3. Model IC693CPU323 (10-slot) Embedded CPU Baseplate

## Modular CPU Baseplates (Figures 3-4 and 3-5)

- A Power Supply module must be plugged into the left slot (which is not numbered) of these baseplates. The left slot is a unique size and type that only supports a Power Supply module.
- A CPU module (or a special Option module) must be installed in Slot 1 of these baseplates. Slot 1 is a unique size and type that only supports a CPU module or a special Option module like the FIP Remote I/O Scanner (IC693BEM330). Slot 1 is labeled CPU/1.
- Slots numbered 2 and above are of a unique size and type that only supports I/O or Option modules.
- Expansion and Remote baseplates are supported, so a 25-pin D-type female expansion connector is located at the right end of the baseplate for connecting to an Expansion or Remote baseplate.
- Since the CPU is modular, it can be replaced or changed to a different type if additional features are desired.
- Only one CPU baseplate is allowed per system. If more than one baseplate is used in a system, the additional ones must be either Expansion or Remote types.
- A modular CPU baseplate is always assigned, by default, Rack Number 0.

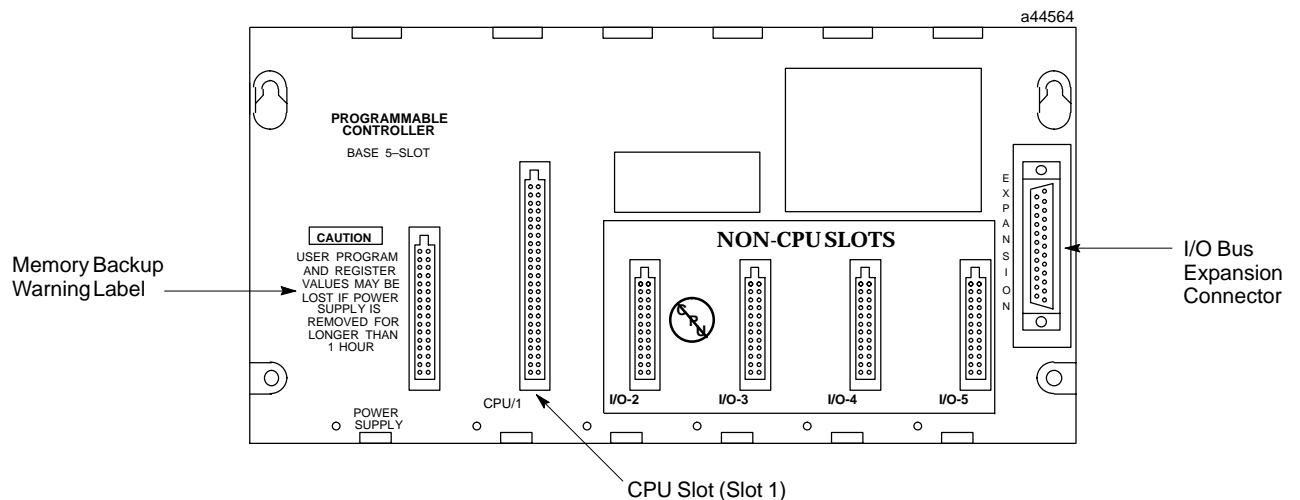

Figure 3-4. IC693CHS397 5-Slot Modular CPU Baseplate

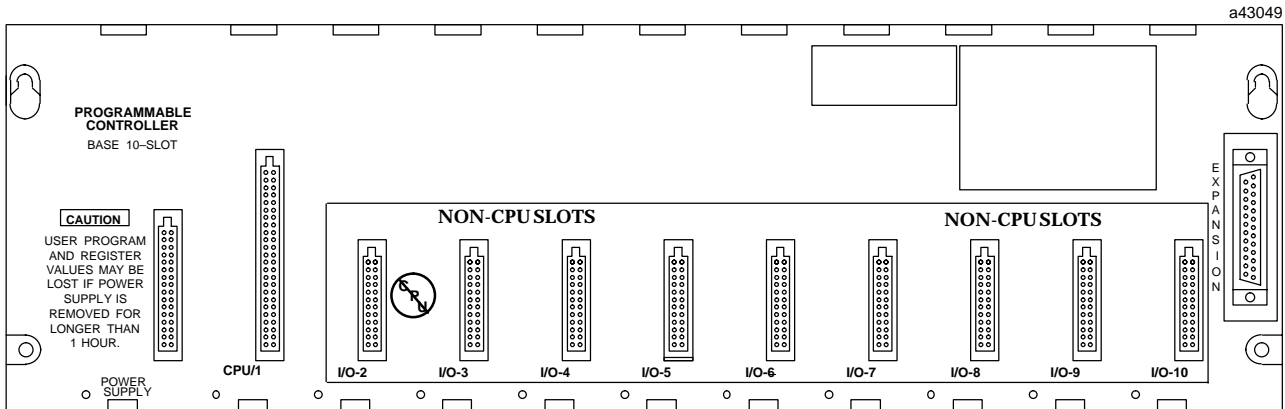

Figure 3-5. IC693CHS391 10-Slot Modular CPU Baseplate

### Expansion Baseplates (Figures 3-6 and 3-7)

- There can be **no more** than a total of 50 feet (15 meters) of cable interconnecting Expansion baseplates and the CPU baseplate.
- An Expansion baseplate cannot stand alone. It must be connected to a system that has a CPU. The CPU can be in a PLC or in a Personal Computer that is equipped with a Personal Computer Interface Card (see Chapter 11).
- Maximum number of Expansion baseplates allowed per system depends on the type of CPU they are used with. For CPUs 331, 340, and 341, the maximum is 4. For CPUs numbered 350 and higher, the maximum is 7.
- Each Expansion baseplate has a 25-pin female D-type I/O Bus Expansion connector mounted at its right end for connection to other baseplates.
- Available in two versions; 5-slot (IC693CHS398) and 10-slot (IC693CHS392)
- An Expansion backplane does not support the following intelligent option modules: PCM, ADC, BEM330, and CMM. These modules must be mounted in a CPU baseplate. All other I/O and option modules can be mounted in any type of rack.
- All Expansion baseplates must be connected to a common ground (see the "Installation" chapter for details).
- Expansion baseplates are the same physical size, use the same type power supplies, and support the same I/O and option modules as the Remote baseplates.
- Each Expansion baseplate has a Rack Number Selection DIP switch.

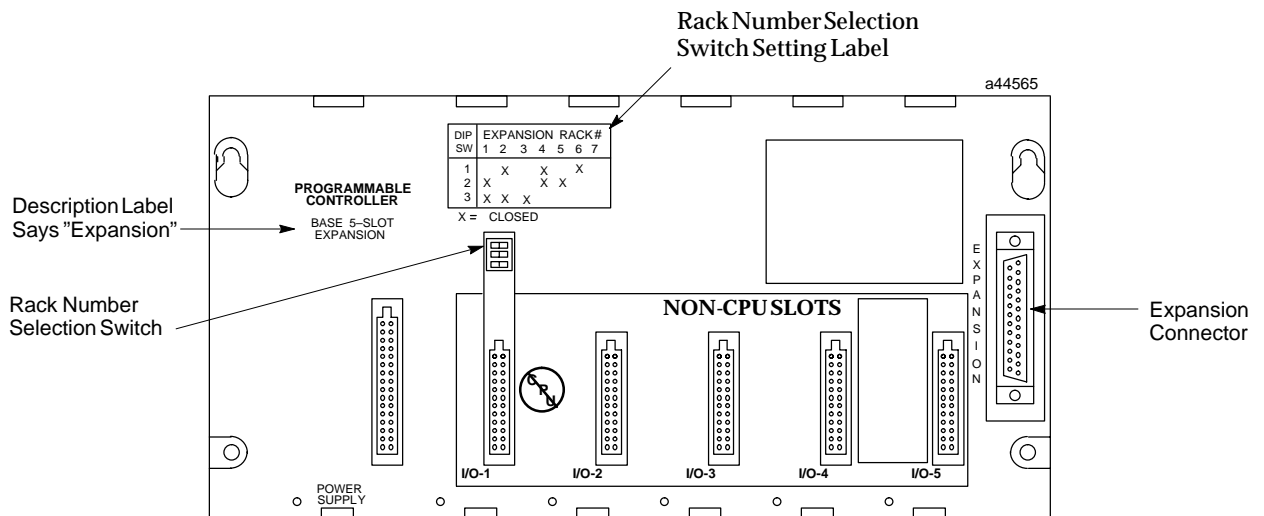

Figure 3-6. IC693CHS398 5-Slot Expansion Baseplate

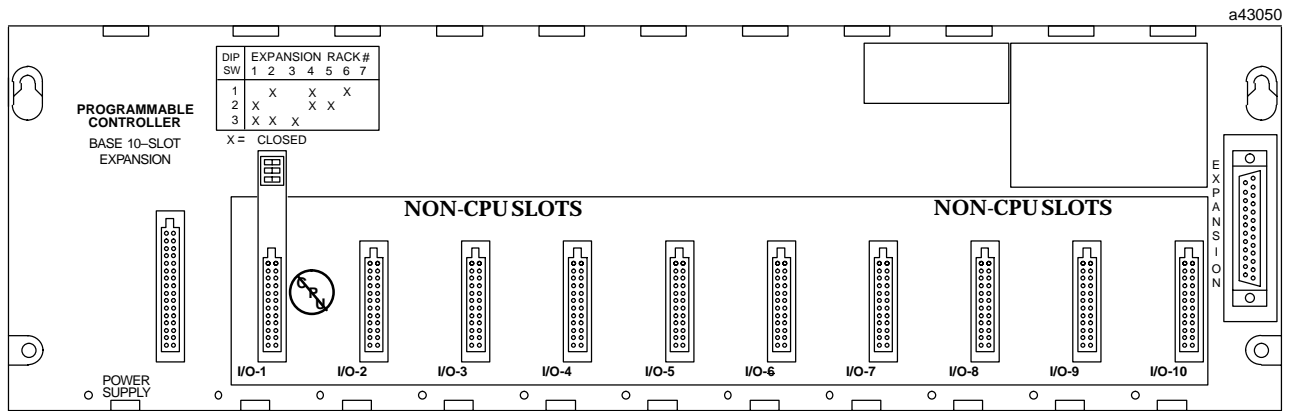

Figure 3-7. IC693CHS392 10-Slot Expansion Baseplate

## Remote Baseplates (Figures 3-8 and 3-9)

- There can be no more than 700 feet of cable connecting all baseplates in a system that uses Remote baseplates.
- A Remote baseplate cannot stand alone. It must be connected to a system that has a CPU. The CPU can be in a PLC or in a Personal Computer that is equipped with a Personal Computer Interface Card (see Chapter 11).
- Remote capability is facilitated by the Remote baseplate's built-in isolation between the +5 volt logic supply used by the I/O modules residing in the Remote baseplate and the supply for the interface circuit associated with the I/O Bus Expansion Interface. Isolation helps prevent problems associated with unbalanced ground conditions.
- Maximum number of Remote baseplates allowed per system depends on the type of CPU they are used with. For CPUs 331, 340, and 341, the maximum is 4. For CPUs numbered 350 and higher, the maximum is 7.
- Each remote baseplate has a 25-pin female D-type Expansion connector mounted at its right end for connection to other baseplates.
- Remote baseplates are available in two sizes; 5-slot (IC693CHS398) and 10-slot (IC693CHS392)
- A Remote backplane does not support the following intelligent option modules: PCM, ADC, BEM330, and CMM. These modules must be mounted in a CPU baseplate. All other I/O and option modules can be mounted in any type of baseplate.
- Remote baseplates are the same physical size, use the same type power supplies, and support the same I/O and option modules as the Expansion baseplates.
- Each Remote baseplate has a Rack Number Selection DIP switch.

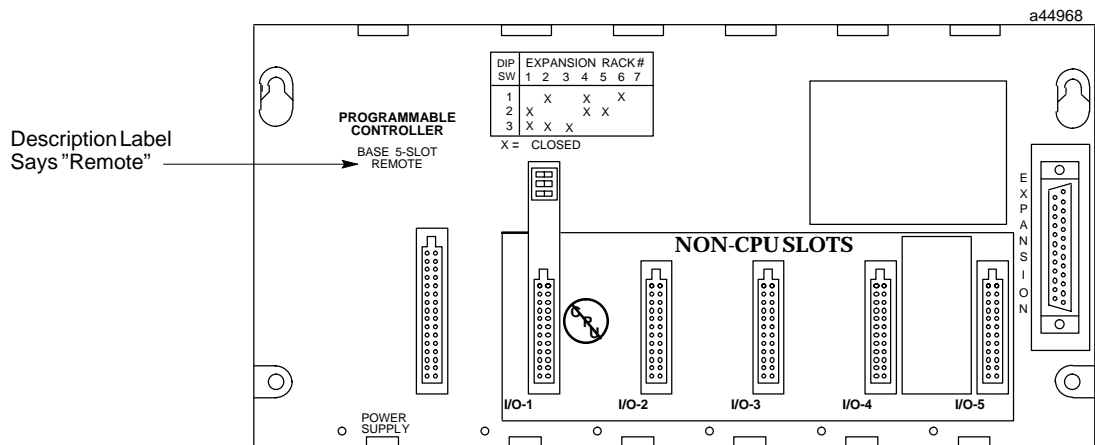

Figure 3-8. IC693CHS399 5-Slot Remote Baseplate

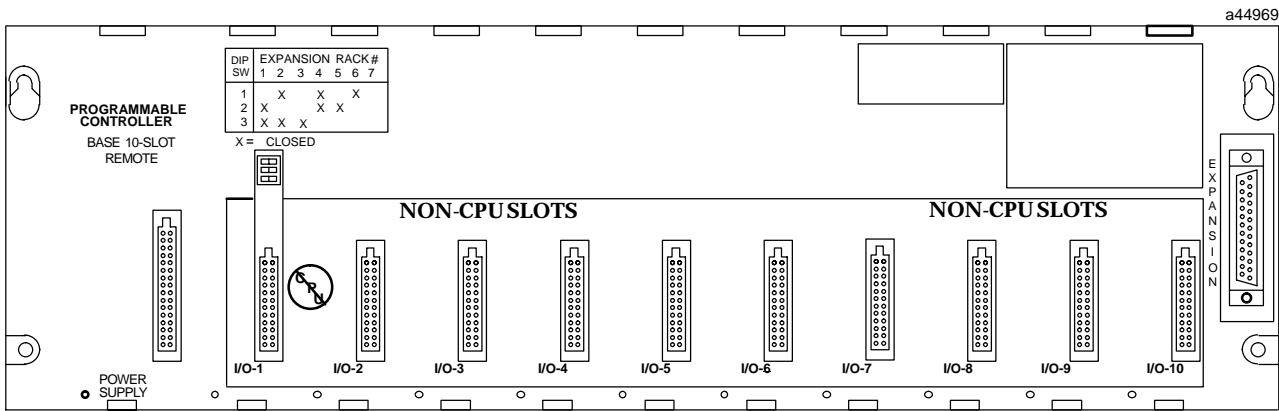
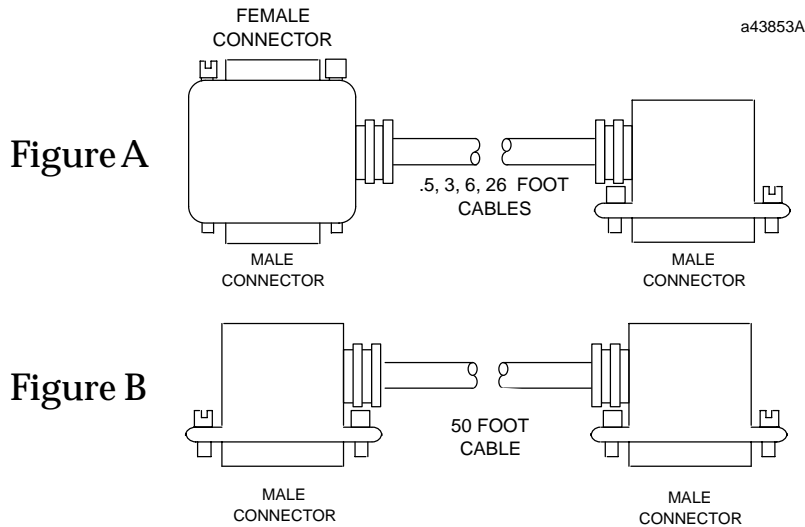

Figure 3-9. IC693CHS393 10-Slot Remote Baseplate

## I/O Bus Expansion Cables

Five prewired I/O Bus Expansion cables are available from GE Fanuc. Catalog numbers and lengths of these cables are listed in the following figure. You can build custom cables to suit the needs of your application if cable lengths other than those listed are required. Refer to the “Cables” chapter for detailed information on cable type and connectors. Note that the same cables can be used with both Expansion and Remote baseplates, however the cables used in a remote expansion system *must* use the cable type described in the “Cables” chapter.



| Catalog Number | Length  | Figure |
|----------------|---|--------|
| IC693CBL300    | 3 feet (1 meter), continuous shield   | A      |
| IC693CBL301    | 6 feet (2 meters), continuous shield  | A      |
| IC693CBL302    | 50 feet (15 meters), continuous shield with built in terminator (this is not a Wye cable) | B      |
| IC693CBL312    | 0.5 feet (.15 meters), continuous shield  | A      |
| IC693CBL313    | 25 feet (8 meters), continuous shield   | A      |

Figure 3-10. I/O Bus Expansion Cables

### Note

The 3 foot cable (IC693CBL300) can be used as a Wye adapter between custom-built cables and Remote baseplates.

## Differences Between Remote and Expansion Racks

Basically, Remote racks provide the same functionality as Expansion racks, but with the longer distance (700 feet/213 meters versus 50 feet/15 meters for Expansion racks) capability. To minimize unbalanced ground conditions, Remote baseplates have extra

isolation circuitry. Unbalanced ground conditions can occur when systems are located long distances from each other and do not share the same ground system. However, distance is not always the problem; even racks that are mounted near each other can experience problems if the system is not grounded properly. See Chapter 2 for grounding information.

The use of Remote racks requires a special consideration pertaining to scan time. In order to operate at long distances, the I/O Bus runs at a lower clock speed (compared to that used for Expansion racks) when communicating with Remote racks, which will have an impact on performance. The impact will be relatively small for discrete I/O and slightly more for other modules, such as the High Speed Counter or Genius Communications Module. The increase in time needed to communicate with modules in a remote baseplate will usually be small with respect to the overall scan time. For more detailed information on scan time calculations, refer to Chapter 2 of GFK-0467, the *Series 90-30/20/Micro PLC CPU Instruction Set Reference Manual*.

Another important scan time consideration is the cable type used for communicating at longer distances. Data propagation delay must be minimized to ensure proper system timing and margins. Any deviation in cable type may result in erratic or improper system operation. Suggested cable types are specified in the “Cables” chapter in the IC693CBL300/etc. data sheet.

## Mixing Expansion and Remote Baseplates in a System

Expansion and remote baseplates can be used in the same system as long as certain requirements are met:

- You do not exceed the 50 foot (15 meter) maximum cable distance from the CPU to the last Expansion baseplate
- You do not exceed the 700 foot (213 meter) maximum cable distance from the CPU to the last Remote baseplate.
- The cable type recommended for use with Remote baseplates must be used throughout the system. The exception to this requirement is that the prewired 3 foot (1 meter) cable, IC693CBL300, can be used as a Wye adapter to simplify the custom cable assembly associated with the “daisy chain” connections between baseplates. Information on building cables for use with Remote baseplates can be found in the “Cables” chapter in the IC693CBL300/etc. data sheet..

## Termination Requirement for Expansion or Remote System

When two or more baseplates are connected via the I/O Bus Expansion System, the I/O Expansion Bus must be properly terminated. The most common method of terminating the I/O Expansion Bus is by installing a termination resistor pack (IC693ACC307) on the open connector on the last (most distant from the CPU) Expansion or Remote baseplate in the system. The resistor pack is physically mounted inside of a connector. Although a termination resistor pack is shipped with each baseplate, only the last baseplate in the chain needs to have this termination connector installed. Unused termination packs can be discarded. The prewired 50 foot (15 meter) cable (IC693CBL302) has termination resistors wired inside the connector on one end of the cable. This cable can be used if only one expansion rack is needed in a system and a 50 foot cable link is required (the IC693ACC307 resistor pack is not needed in this case). Also, a custom-built cable with built-in resistors would eliminate the need for the IC693ACC307 resistor pack.

## Powering Down Individual Expansion or Remote Baseplates

Expansion or Remote baseplates can be powered-down individually without affecting the operation of other baseplates; however, powering off a baseplate generates a loss of module (LOSS\_OF\_MODULE) fault in the PLC Fault Table for each module in the baseplate. When this fault condition occurs, and until the baseplate is powered back on and all modules recovered, the lost I/O modules are not scanned. For more information on the power-up and power-down sequence, see Chapter 2 in the *Series 90-30 Programmable Controller Reference Manual*, GFK-0467.

## Series 90-30 PLC Backplane

The Series 90-30 PLC backplane (on all three types of baseplates) has a dedicated I/O communications bus. The signals on the remote baseplate backplane are optically coupled and an isolated DC-DC power supply converter is provided to isolate the signals from other backplanes.

- **Power bus** – connects the power supply outputs to the modules in the baseplate.
- **I/O Communications bus** – the CPU communicates with I/O modules over this bus. This bus is connected to the I/O busses in Expansion and Remote racks via the I/O Bus Expansion connectors and cables.
- **Special Intelligent Module bus** – exists only on a CPU baseplate; therefore, certain special intelligent option modules, such as the PCM, ADC, and CMM modules, will only work in a CPU baseplate.

## Rack Number DIP Switch on Expansion and Remote Baseplates

Each baseplate in a Series 90-30 system is identified with a unique number called a “Rack Number.” Rack Numbers for Expansion and Remote baseplates are selected by setting a DIP switch located on each baseplate directly above the connector for Slot 1. Rack number 0 must always be present and is assigned, by default, to the CPU rack (the CPU baseplate does not have this DIP switch). Racks do not need to be contiguously numbered, although for consistency and clarity, it is recommended that rack numbers not be skipped (use 1, 2, 3 - not 1, 3, 5). Rack numbers must not be duplicated within a system. The following table shows the DIP switch positions for rack number selection.

**Table 3-1. Rack Number Selection Switch Settings**

|            | Rack Number |        |        |        |        |        |      |
|------------|-------------|--------|--------|--------|--------|--------|------|
| DIP Switch | 1           | 2      | 3      | 4      | 5*     | 6*     | 7*   |
| 1          | open        | closed | open   | closed | open   | closed | open |
| 2          | closed      | open   | open   | closed | closed | open   | open |
| 3          | closed      | closed | closed | open   | open   | open   | open |

\* Rack numbers 5, 6, and 7 only valid for CPUs 350 and higher.

The particular CPU module used determines how many expansion and remote baseplates are allowed:

- The 331, 340, and 341 CPUs support a total of 4 Expansion and/or Remote racks.
- The 350, 351, 352, 360, 363, and 364 CPUs support a total of 7 Expansion and/or Remote racks.

Each baseplate has a label above the DIP switch that shows the settings for each rack number. The following figure shows this DIP switch package with an example of rack #2 number selected.

**Note**

Use a ball-point pen to set the DIP switches. In general, it is best to avoid using a pencil to set DIP switches since graphite (a gritty, conductive material) from the pencil can enter and damage the switch.

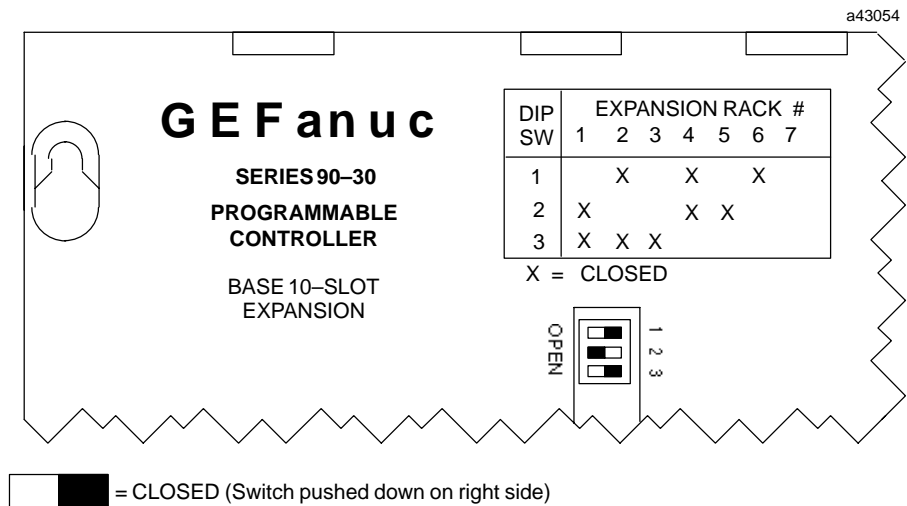

Figure 3-11. Rack Number Selection Switch (Shown with Rack 2 Selected)

## Expansion Rack Connection Example

The following example shows a system that includes Expansion baseplates.

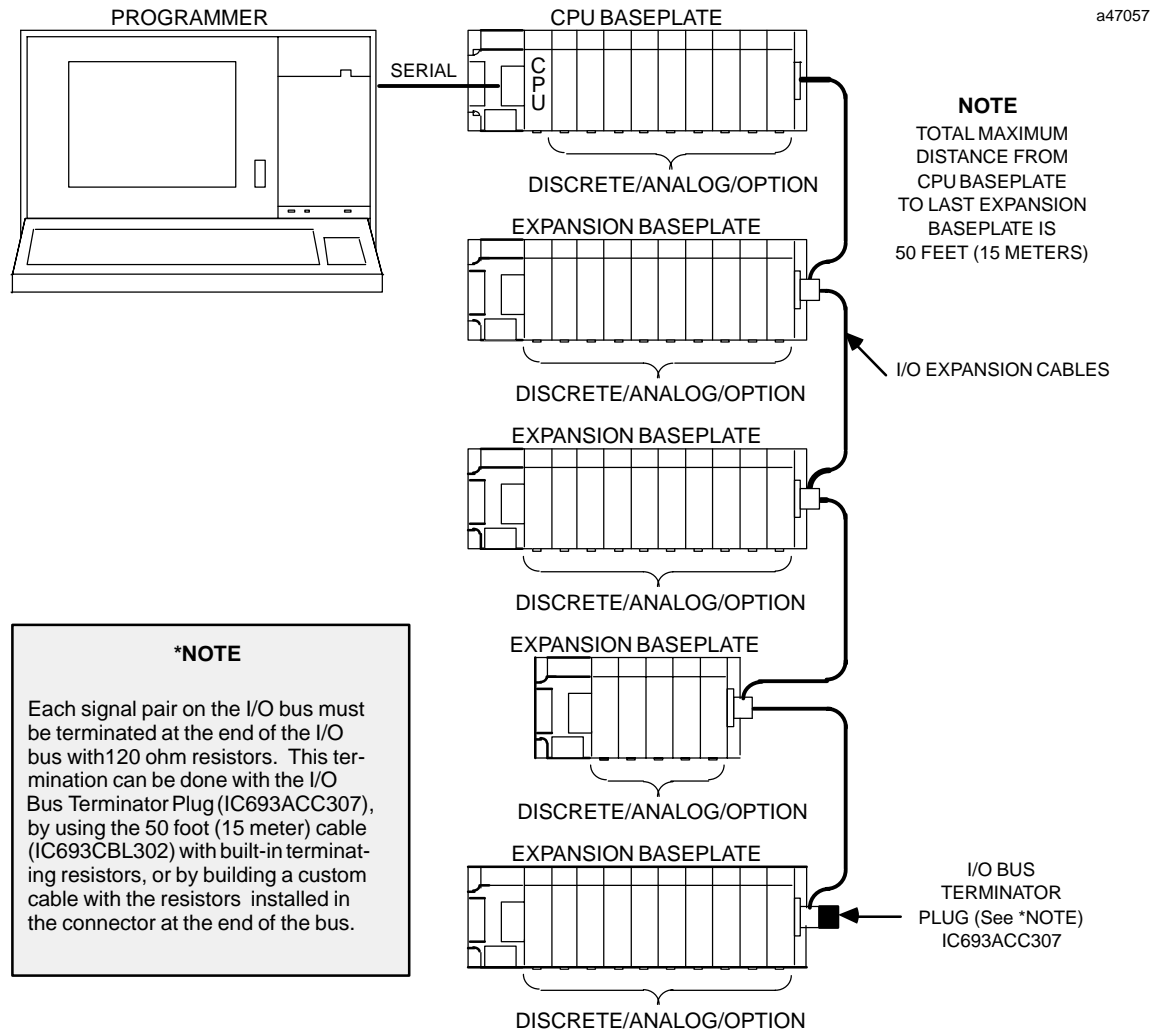

Figure 3-12. Example of Connecting Expansion Baseplates

### Expansion and Remote Baseplates Connection Example

The following example shows cable connections in a system that includes both remote and expansion baseplates. A system can have a combination of remote and expansion baseplates as long as the distance and cable requirements are followed.

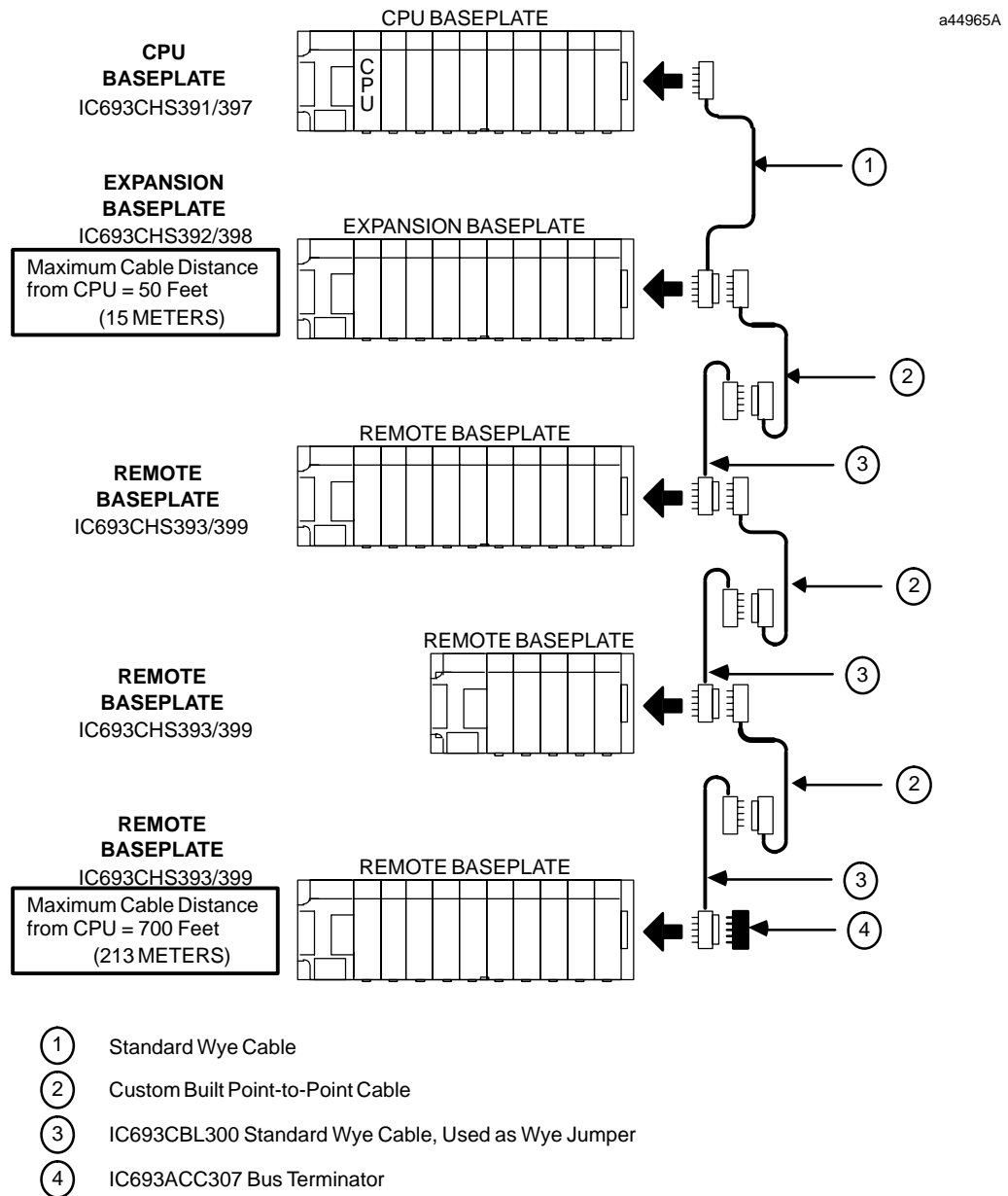

Figure 3-13. Example of Connecting Expansion and Remote Baseplates

# Baseplate Mounting Dimensions

Series 90-30 PLC baseplates are designed to be panel mounted. Each baseplate has standard attachment flanges for mounting on an electrical panel. Baseplate dimensions and proper spacing requirements for installation purposes for both the 5 and 10-slot baseplates with embedded CPU (Models 311 and Model 313 are 5-slot baseplates; Model 323 is a 10-slot baseplate), and the 5 and 10-slot baseplates for Modular CPUs are shown in figures 3-1 through 3-4.

## Note

All 5-slot baseplates have the same mounting dimensions and all 10-slot baseplates have the same mounting dimensions. *Baseplates must be mounted in the orientation as shown in the following figures for proper cooling.*

## Embedded CPU (311, 313, and 323) Baseplate Dimensions

Baseplate dimensions and spacing requirements for installation for Models 311, 313, and 323 baseplates are shown below.

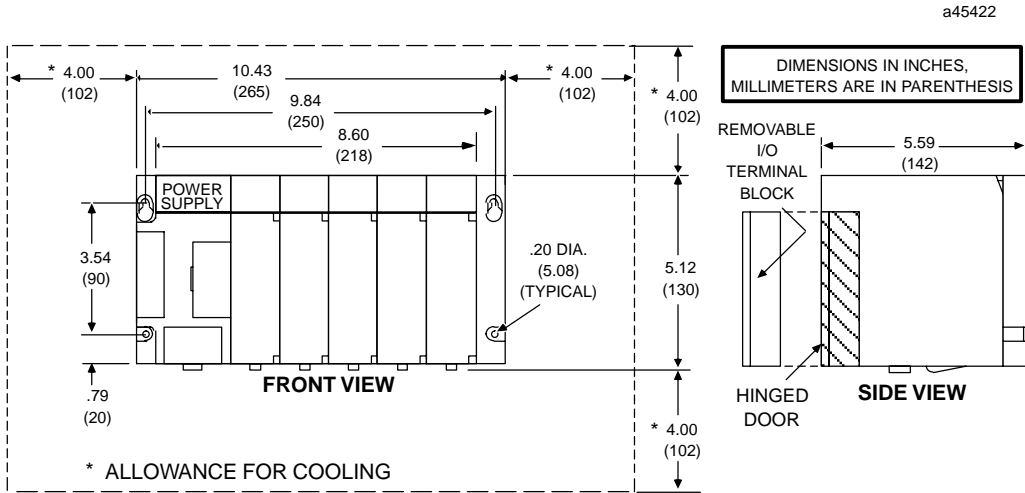

Figure 3-14. Model311 and 313 5-Slot Baseplate Dimensions and Spacing Requirements

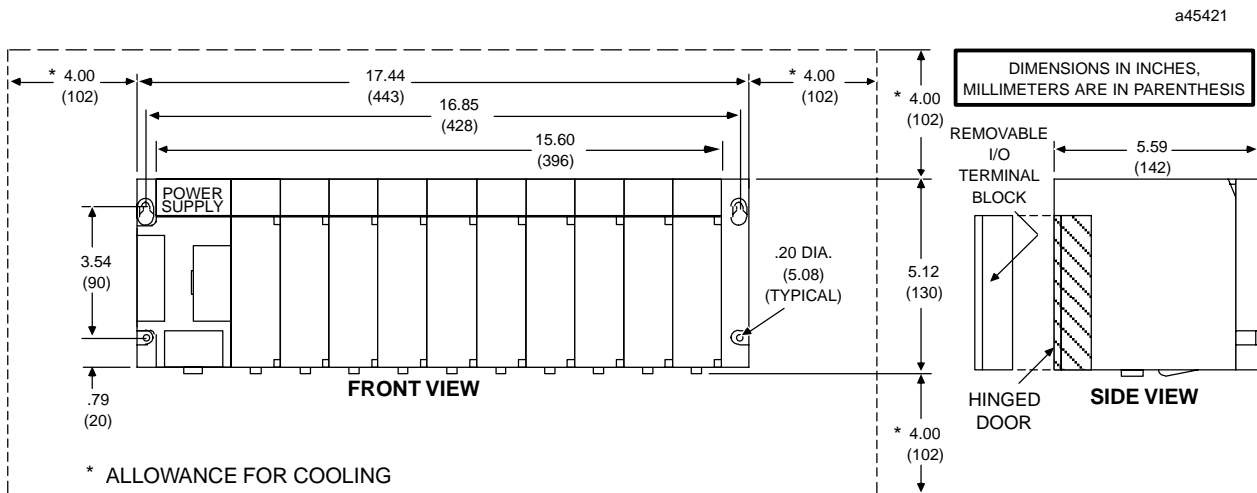

Figure 3-15. Model323 10-Slot Baseplate Dimensions and Spacing Requirements

### Modular CPU, Expansion, and Remote Baseplate Dimensions

Baseplate dimensions and spacing requirements for installation for Modular CPU baseplates are shown below.

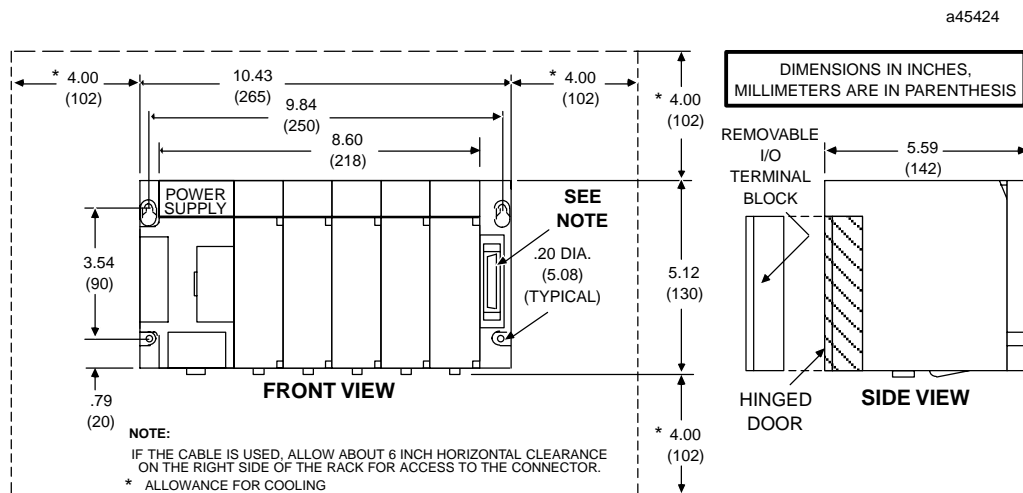
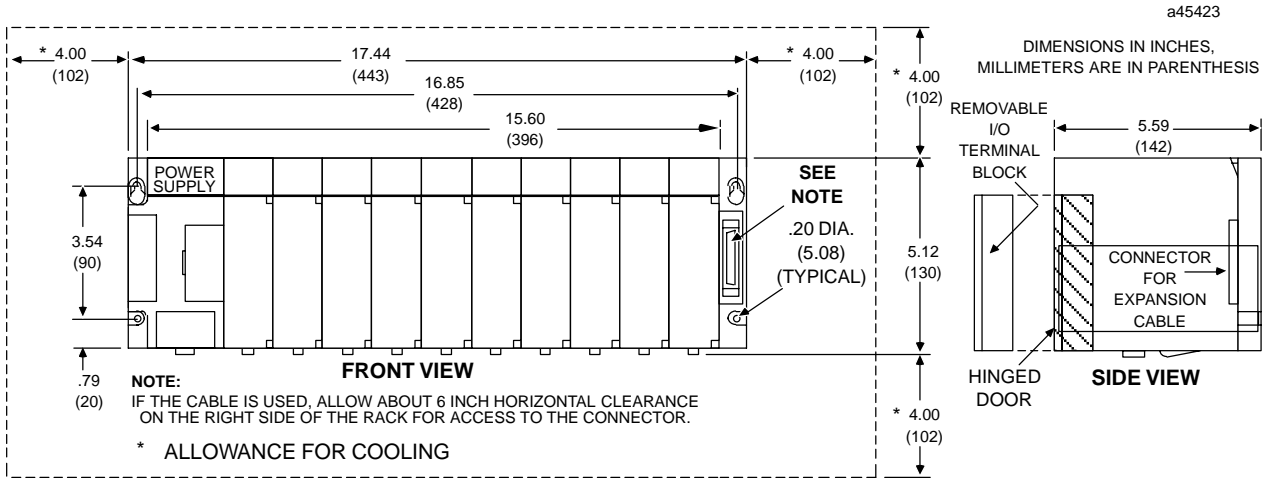

Figure 3-16. Modular CPU, Expansion, and Remote 5-Slot Baseplate Dimensions and Spacing Requirements



**Figure 3-17. Modular CPU, Expansion, and Remote 10-Slot Baseplate Dimensions and Spacing Requirements**

### Load Ratings, Temperature, and Mounting Position

The power supply load rating depends on the mounting position of the baseplate and the ambient temperature.

The load rating with the baseplate mounted upright on a panel is:

- 100% at 60°C (140°F)

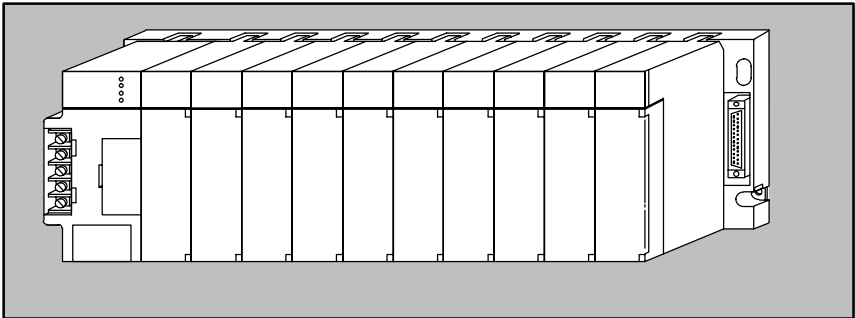

Power supply load ratings with the baseplate mounted horizontally are:

- temperature at 25°C (77°F) - full load
- temperature at 60°C (140°F) - 50% of full load

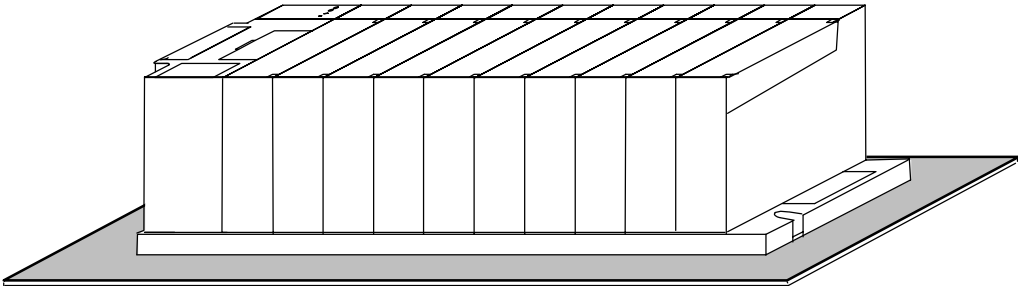

## Baseplate Adapter Brackets for 19" Rack Mounting

Two optional Baseplate Adapter Brackets allow a 10-slot baseplate to be mounted in a 19 inch rack. Each baseplate installation requires only one of the adapter brackets.

### Warning

**Be sure to follow grounding instructions in Chapter 2 when using these adaptor brackets. Failure to properly ground the PLC can result in improper operation, damage to equipment, and injury to personnel.**

- IC693ACC308 Front Mount Adapter Bracket.** Used to mount a baseplate to the front face of a 19" rack. Install the adapter bracket by inserting the tabs at the top and bottom of the adapter bracket into the corresponding slots at the top and bottom of the plastic baseplate cover. **NOTE: Although the figure below shows the plastic baseplate cover removed, this is for illustration purposes only. It is not necessary to remove the cover to install the bracket.** With the bracket in place, insert and tighten the two screws (included with the bracket) through the back of the baseplate holes into the threaded holes in the bracket.
- IC693ACC313 Recessed Mount Adapter Bracket.** Used to recess mount a baseplate inside a 19" rack. A baseplate mounts on the rear panel of this adapter bracket using four 8-32 (4 mm) screws, nuts, lockwashers and flat washers. The Adapter Bracket bolts through its four slotted holes to the face of the 19" rack using applicable hardware (lockwashers recommended).

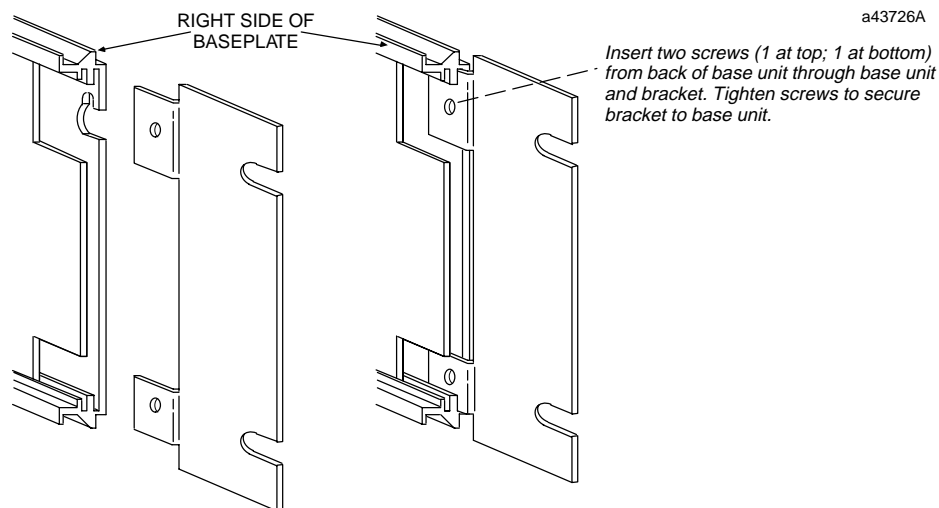

**Note:** Baseplate is shown with cover removed for illustration purposes. It is not necessary to remove the baseplate cover to install the bracket.

Figure 3-18. IC693ACC308 Front Mount Adapter Bracket Installation

Dimensions for rack mounting a 10-slot baseplate with the IC693ACC308 Front Mount Adapter Bracket are shown in the following figure.

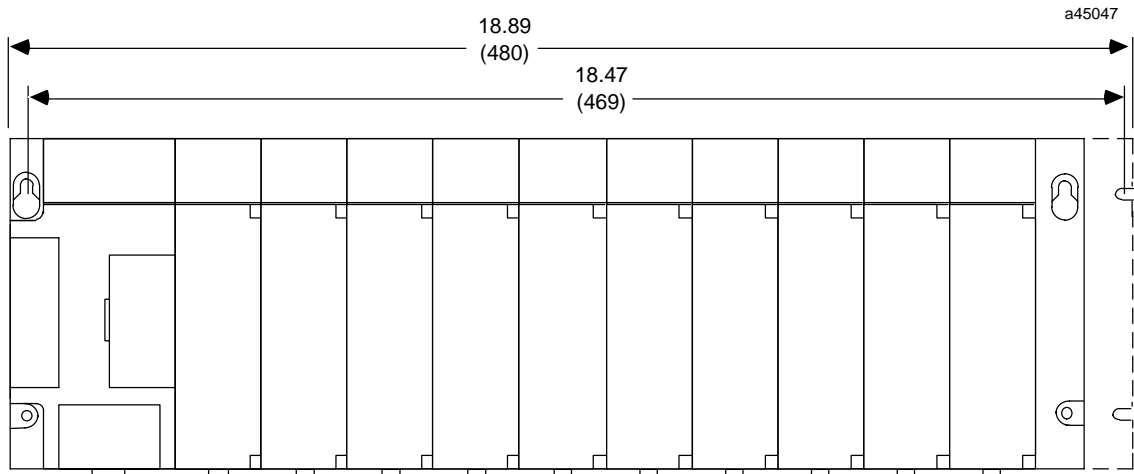

DIMENSIONS IN INCHES (MILLIMETERS IN PARENTHESES)

Figure 3-19. Dimensions for 19" Rack Mounting Using IC693ACC308 Adapter Bracket

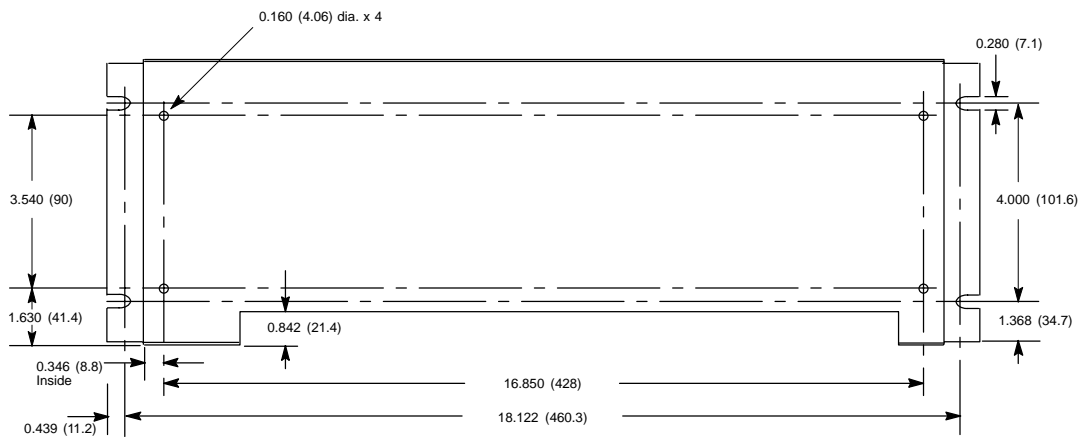

DIMENSIONS IN INCHES (MILLIMETERS IN PARENTHESES)

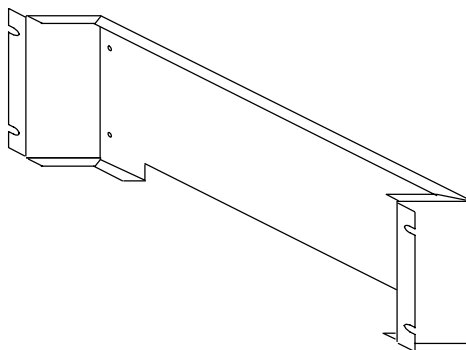

Figure 3-20. IC693ACC313 Recessed Mount Adapter Bracket

## Baseplate Comparison Table

Table 3-2. Series 90-30 Baseplate Comparison

| Series 90-30 Baseplates |              |              |
|-------------------------|--------------|--------------|
| Catalog Number          | Type         | Size (Slots) |
| IC693CPU311             | Embedded CPU | 5            |
| IC693CPU313             | Embedded CPU | 5            |
| IC693CPU323             | Embedded CPU | 10           |
| IC693CHS397             | Modular CPU  | 5            |
| IC693CHS391             | Modular CPU  | 10           |
| IC693CHS398             | Expansion    | 5            |
| IC693CHS392             | Expansion    | 10           |
| IC693CHS399             | Remote       | 5            |
| IC693CHS393             | Remote       | 10           |

# Chapter 4

## Power Supplies

[efesotomasyon.com](http://efesotomasyon.com)

### Power Supply Categories

Series 90-30 power supplies are modular types that plug into the left slot of all 90-30 baseplates. They have been placed into two categories for the purpose of this chapter:

#### AC/DC Input Power Supplies

- IC693PWR321, Standard 120/240 VAC or 125 VDC input, 30 watts total output
- IC693PWR330, High Capacity 120/240 VAC or 125 VDC input, 30 watts total output

#### DC Input-Only Power Supplies

- IC693PWR322, 24/48 VDC input, 30 watts total output
- IC693PWR328 48 VDC input, 30 watts total output
- IC693PWR331, High Capacity 24 VDC input, 30 watts total output

### Power Supply Feature Comparison

The following table lists the features of the Series 90-30 PLC Power Supplies.

Table 4-1. Power Supply Comparison Table

| Catalog Number | Load Capacity | Nominal Input             | Output Capacities (Voltage/Power †) |                              |                           |
|----------------|---------------|---------------------------|-------------------------------------|------------------------------|---------------------------|
| IC693PWR321    | 30 Watts      | 100 to 240 VAC or 125 VDC | +5 VDC<br>15 watts                  | +24 VDC Isolated<br>20 watts | +24 VDC Relay<br>15 watts |
| IC693PWR330    | 30 Watts      | 100 to 240 VAC or 125 VDC | +5 VDC<br>30 watts                  | +24 VDC Isolated<br>20 watts | +24 VDC Relay<br>15 watts |
| IC693PWR322    | 30 Watts      | 24 or 48 VDC              | +5 VDC<br>15 watts                  | +24 VDC Isolated<br>20 watts | +24 VDC Relay<br>15 watts |
| IC693PWR328    | 30 Watts      | 48 VDC                    | +5 VDC<br>15 watts                  | +24 VDC Isolated<br>20 watts | +24 VDC Relay<br>15 watts |
| IC693PWR331    | 30 Watts      | 24 VDC                    | +5 VDC<br>30 watts                  | +24 VDC Isolated<br>20 watts | +24 VDC Relay<br>15 watts |

† Total of all outputs combined cannot exceed 30 watts.

## AC/DC Input Power Supplies

### IC693PWR321 Standard Power Supply, 120/240 VAC or 125 VDC Input

The IC693PWR321 is a 30 watt supply that can operate from an input voltage source in the range of 85 to 264 VAC or 100 to 300 VDC. This power supply provides three outputs:

- + 5 VDC output,
- + 24 VDC "Relay" power output which provides power to circuits on Series 90-30 Output Relay modules.
- "Isolated" +24 VDC, which is used internally by some modules, can also be used to provide external power for 24 VDC Input modules.

The load capacity for each output of this power supply is shown in the following table.

Table 4-2. IC693PWR321 Power Supply Capacities

| Catalog Number | Load Capacity | Nominal Input                | Output Capacities (Voltage/Power †) |                              |                           |
|----------------|---------------|------------------------------|-------------------------------------|------------------------------|---------------------------|
|                |               |                              | +5 VDC<br>15 watts                  | +24 VDC Isolated<br>20 watts | +24 VDC Relay<br>15 watts |
| IC693PWR321    | 30 Watts      | 100 to 240 VAC or<br>125 VDC |                                     |                              |                           |

† Total of all outputs combined cannot exceed 30 watts.

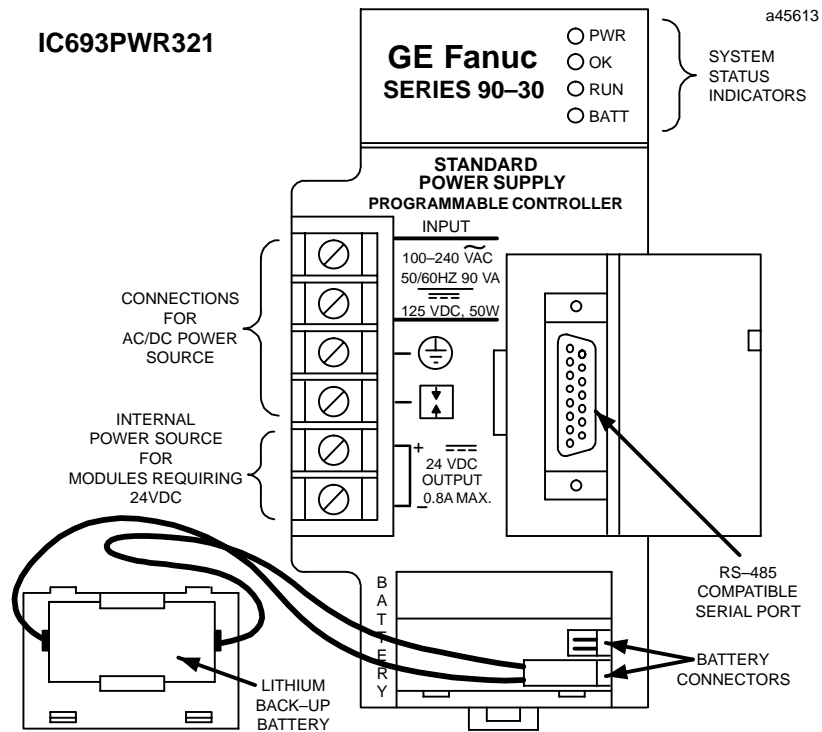

Figure 4-1. Standard AC/DC Input Power Supply - IC693PWR321

Power supplies must be installed in the leftmost slot in all baseplates.

### Note

Previous versions of this power supply had five terminals on the terminal block. The new version (shown above), which has six terminals, is functionally the same as the previous version. The change was made to conform to European EC requirements.

**Table 4-3. Specifications for IC693PWR321 Standard AC/DC Input Power Supply**

|   |  |
|---|--|
| <b>Nominal Rated Voltage</b>                | 120/240VAC or 125 VDC  |
| <b>Input Voltage Range</b>                  |  |
| AC  | 85 to 264 VAC  |
| DC  | 100 to 300 VDC   |
| <b>Input Power (Maximum with Full Load)</b> | 90 VA with VAC Input<br>50 W with VDC Input  |
| <b>Inrush Current</b>                       | 4A peak, 250 milliseconds maximum  |
| <b>Output Power</b>                         | 5 VDC and 24 VDC Relay: 15 watts maximum<br>24 VDC Relay: 15 watts maximum<br>24 VDC Isolated: 20 watts maximum<br><i>NOTE: 30 watts maximum total (all three outputs)</i> |
| <b>Output Voltage</b>                       | 5 VDC: 5.0 VDC to 5.2 VDC (5.1 VDC nominal)<br>Relay 24 VDC: 24 to 28 VDC<br>Isolated 24 VDC: 21.5 VDC to 28 VDC   |
| <b>Protective Limits</b>                    |  |
| <b>Overvoltage:</b>                         | 5 VDC output: 6.4 to 7 V   |
| <b>Overcurrent:</b>                         | 5 VDC output: 4 A maximum  |
| <b>Holdup Time:</b>                         | 20 milliseconds minimum  |

## IC693PWR330 High Capacity Power Supply, 120/240 VAC/125 VDC Input

The IC693PWR330 High Capacity Power Supply is rated for 30 watts output. *For applications requiring greater +5V current capacity than is available with the standard supply (IC693PWR321), this supply allows all 30 watts to be consumed from the +5V supply.* It can operate from an input voltage source in the range of 85 to 264 VAC or 100 to 300 VDC. This power supply provides the following outputs:

- + 5 VDC output.
- + 24 VDC "Relay" power output which provides power to circuits on Series 90-30 Output Relay modules.
- "Isolated" +24 VDC, which is used internally by some modules, can also be used to provide external power for 24 VDC Input modules.

The load capacity for each output of this power supply is shown in the following table.

Table 4-4. IC693PWR330 Power Supply Capacities

| Catalog Number | Load Capacity | Nominal Input             | Output Capacities (Voltage/Power †) |                              |                           |
|----------------|---------------|---------------------------|-------------------------------------|------------------------------|---------------------------|
| IC693PWR330    | 30 Watts      | 100 to 240 VAC or 125 VDC | +5 VDC<br>30 watts                  | +24 VDC Isolated<br>20 watts | +24 VDC Relay<br>15 watts |

† Total of all outputs combined cannot exceed 30 watts.

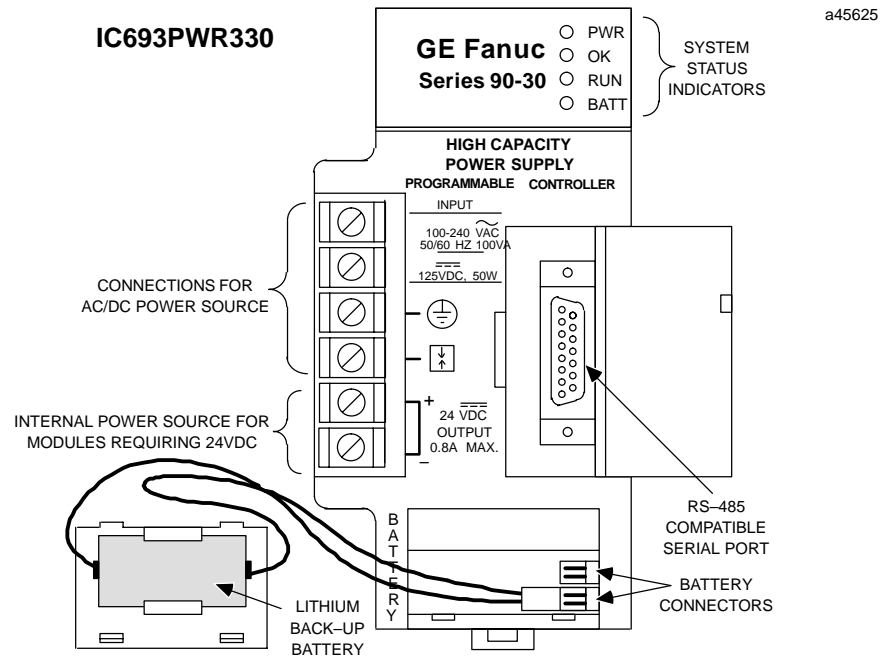

Figure 4-2. High Capacity AC/DC Input Power Supply - IC693PWR330

Table 4-5. Specifications for IC693PWR330 High Capacity AC/DC Input Power Supply

|   |  |
|---|--|
| <b>Nominal Rated Voltage</b>                | 120/240VAC or 125 VDC  |
| <b>Input Voltage Range</b>                  |  |
| AC  | 85 to 264 VAC  |
| DC  | 100 to 300 VDC   |
| <b>Input Power (Maximum with Full Load)</b> | 100 VA with VAC Input<br>50 W with VDC Input   |
| <b>Inrush Current</b>                       | 4A peak, 250 ms maximum  |
| <b>Output Power</b>                         | <b>5 VDC:</b> 30 watts maximum<br><b>24 VDC Relay:</b> 15 watts maximum<br><b>24 VDC Isolated:</b> 20 watts maximum<br><i>NOTE: 30 watts maximum total (all three outputs)</i> |
| <b>Output Voltage</b>                       | <b>5 VDC:</b> 5.0 VDC to 5.2 VDC (5.1 VDC nominal)<br><b>24 VDC Relay:</b> 24 to 28 VDC<br><b>24 VDC Isolated:</b> 21.5 VDC to 28 VDC  |
| <b>Protective Limits</b>                    |  |
| <b>Overvoltage:</b>                         | <b>5 VDC output:</b> 6.4 to 7 V  |
| <b>Overcurrent:</b>                         | <b>5 VDC output:</b> 7 A maximum   |
| <b>Holdup Time:</b>                         | 20 ms minimum  |

## Field Wiring Connections for the AC/DC Input Power Supplies

The two AC/DC input power supplies have six terminals for user connections. These connections are described below.

### AC Power Source Connections

The Hot, Neutral, and Ground wires from the 120 VAC power source or L1, L2, and Ground wires from the 240 VAC power source connect to the system through the top three terminals of the terminal strip on the front of the power supply.

### DC Power Source Connections

Connect the + and – wires from the 125 VDC (nominal) power source to the top two terminals on the terminal connector. These connections are not polarity-sensitive on an AC/DC input power supply. (However, the DC Input-only type supplies, which are discussed later in this chapter, are polarity sensitive.)

### Input Overvoltage Protection Devices

**This information applies to all Series 90-30 power supplies except IC693PWR322 and IC693PWR328.** The overvoltage protection devices for this power supply are connected internally to pin 4 on the user terminal strip. This pin is normally connected to frame ground (pin 3) with the supplied jumper strap which is installed at the factory. If overvoltage protection is not required *or* is supplied upstream, this feature can be disabled by removing the jumper strap from pins 3 and 4.

If you want to Hi-pot test this supply, overvoltage protection *must be disabled* during the test by removing the terminal strip jumper strap. Re-enable overvoltage protection after testing by reinstalling the strap.

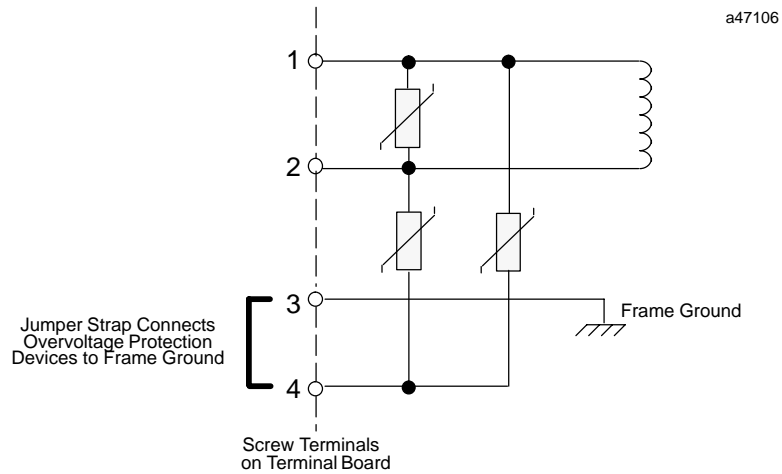

Figure 4-3. Overvoltage Protection Devices and Jumper Strap

### Isolated 24 VDC Supply Output Connections

The bottom two terminals of the power supply terminal strip provide connections to the Isolated +24 volt DC output which can be used to provide power for external circuits (within power limitations of the supply).

**Caution**

**If the Isolated 24 VDC supply is overloaded or shorted, the Programmable Logic Controller will stop operation.**

## DC Input Only Power Supplies

### IC693PWR322 Standard Power Supply, 24/48 VDC Input

The IC693PWR322 is a 30 watt output power supply designed for 24 VDC or 48 VDC nominal inputs. It will accept an input voltage range from 18 VDC to 56 VDC. Although it is capable of maintaining all outputs within specifications with input voltages as low as 18 VDC, it will not start with initial input voltages of less than 21 VDC. This power supply provides the following outputs:

- + 5 VDC output.
- + 24 VDC "Relay" power output which provides power to circuits on Series 90-30 Output Relay modules.
- "Isolated" +24 VDC, which is used internally by some modules, can also be used to provide external power for 24 VDC Input modules.

The load capacity for each output of this power supply is shown in the following table.

Table 4-6. IC693PWR322 Power Supply Capacities

| Catalog Number | Load Capacity | Input        | Output Capacities (Voltage/Power †) |                              |                           |
|----------------|---------------|--------------|-------------------------------------|------------------------------|---------------------------|
| IC693PWR322    | 30 Watts      | 24 or 48 VDC | +5 VDC<br>15 watts                  | +24 VDC Isolated<br>20 watts | +24 VDC Relay<br>15 watts |

† Total of all outputs combined cannot exceed 30 watts.

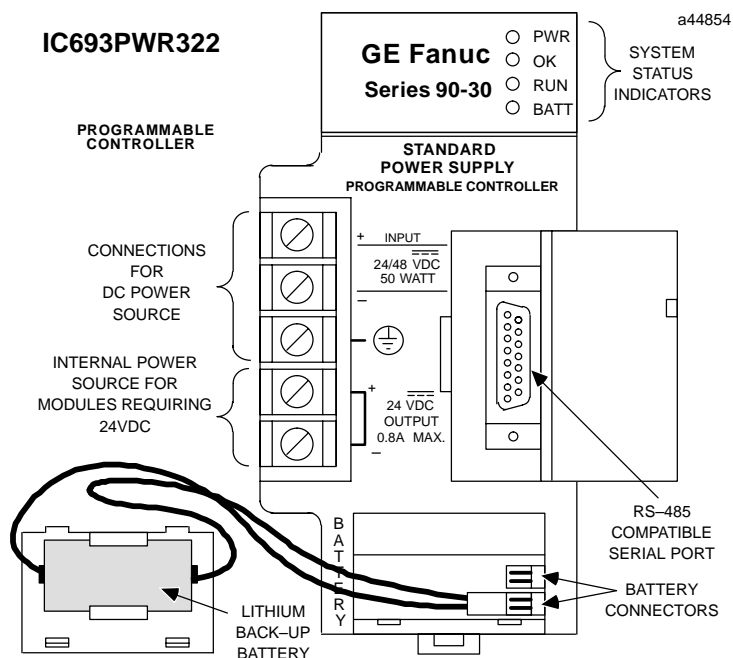

Figure 4-4. Series 90-30 24/48 VDC Input Power Supply - IC693PWR322

Table 4-7. Specifications for IC693PWR322 Power Supply

|                              |  |
|------------------------------|--|
| <b>Nominal Rated Voltage</b> | 24 or 48 VDC   |
| <b>Input Voltage Range</b>   |  |
| <b>Start</b>                 | 21 to 56 VDC   |
| <b>Run</b>                   | 18 to 56 VDC   |
| <b>Input Power</b>           | 50 watts maximum at full load  |
| <b>Inrush Current</b>        | 4A peak, 100 ms maximum  |
| <b>Output Power</b>          | <b>5 VDC:</b> 15 watts maximum<br><b>24 VDC Relay:</b> 15 watts maximum<br><b>24 VDC Isolated:</b> 20 watts maximum<br><i>NOTE: 30 watts maximum total (all three outputs)</i> |
| <b>Output Voltage</b>        | <b>5 VDC:</b> 5.0 VDC to 5.2 VDC (5.1 VDC nominal)<br><b>24 VDC Relay:</b> 24 to 28 VDC<br><b>24 VDC Isolated:</b> 21.5 VDC to 28 VDC  |
| <b>Protective Limits</b>     |  |
| <b>Overvoltage:</b>          | 5 VDC output: 6.4 to 7 V   |
| <b>Overcurrent;</b>          | 5 VDC output: 4 A maximum  |
| <b>Holdup Time:</b>          | 14 ms minimum  |
| <b>Standards</b>             | Refer to data sheet, GFK-0867B, or later version for product standards, and general specifications.  |

### Calculating Input Power Requirements for IC693PWR322

The following graph is a typical 24/48 VDC power supply efficiency curve. A basic procedure for determining efficiency of the 24/48 VDC power supply follows the figure.

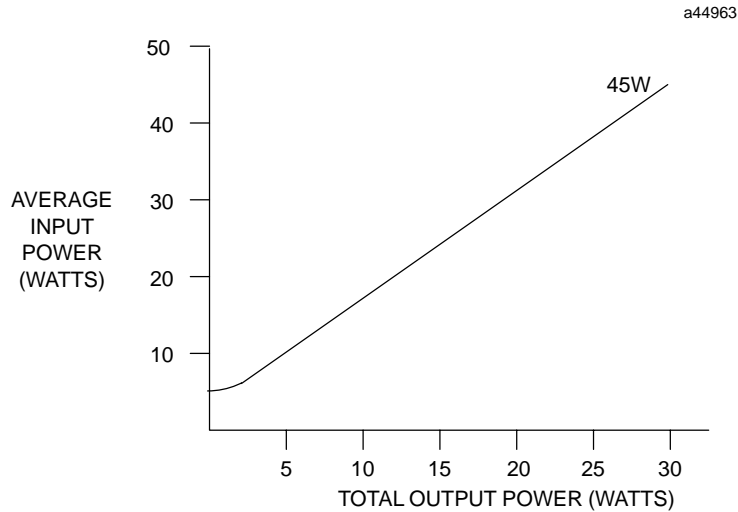

Figure 4-5. Typical Efficiency Curve for 24/48 VDC Power Supply

#### Note

Start-up surge at full load is 4 amps for 250 milliseconds (maximum).

---

### Input Power/Current Calculation

- Determine total output load from typical specifications listed for individual modules in Chapters 2 and 3.
- Use the graph to determine average input power.
- Divide the input power by the operating source voltage to determine the input current requirements.
- Use the lowest input voltage to determine the maximum input current.
- Allow for start-up surge current requirements.
- Allow margins (10% to 20%) for variations.

### IC693PWR328 Standard Power Supply, 48 VDC Input

The IC693PWR328 is a 30 watt output power supply designed for 48 VDC nominal input. It will accept an input voltage range from 38 VDC to 56 VDC. This power supply provides the following outputs:

- + 5 VDC output.
- + 24 VDC "Relay" power output which provides power to circuits on Series 90-30 Output Relay modules.
- "Isolated" +24 VDC, which is used internally by some modules, can also be used to provide external power for 24 VDC Input modules.

The load capacity for each output of this power supply is shown in the following table.

Table 4-8. IC693PWR328 Power Supply Capacities

| Catalog Number | Load Capacity | Input  | Output Capacities (Voltage/Power †) |                              |                           |
|----------------|---------------|--------|-------------------------------------|------------------------------|---------------------------|
| IC693PWR328    | 30 Watts      | 48 VDC | +5 VDC<br>15 watts                  | +24 VDC Isolated<br>20 watts | +24 VDC Relay<br>15 watts |

† Total of all outputs combined cannot exceed 30 watts.

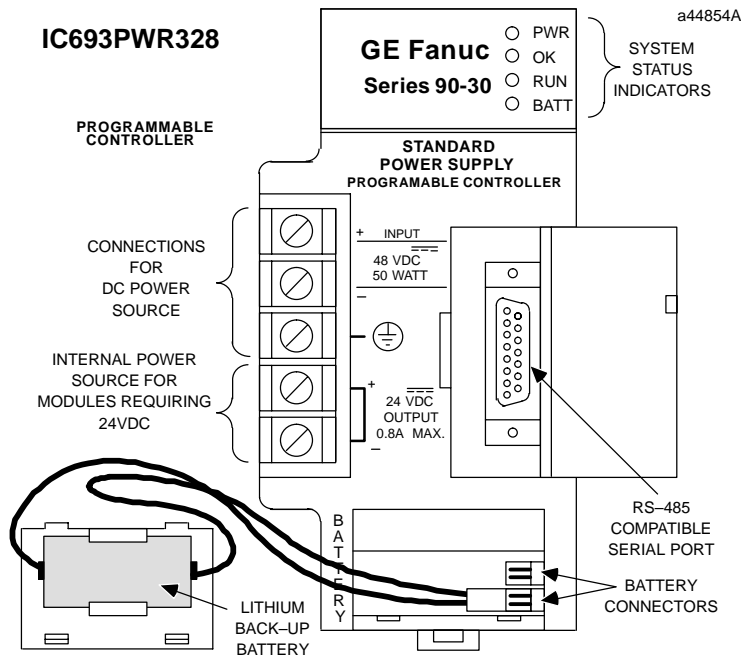

Figure 4-6. Series 90-30 48 VDC Input Power Supply - IC693PWR328

Table 4-9. Specifications for IC693PWR328 Power Supply

|                              |  |
|------------------------------|--|
| <b>Nominal Rated Voltage</b> | 48 VDC   |
| <b>Input Voltage Range</b>   | 38 to 56 VDC   |
| <b>Input Power</b>           | 50 watts maximum at full load  |
| <b>Inrush Current</b>        | 4A peak, 100 ms maximum  |
| <b>Output Power</b>          | <b>5 VDC:</b> 15 watts maximum<br><b>24 VDC Relay:</b> 15 watts maximum<br><b>24 VDC Isolated:</b> 20 watts maximum<br><i>NOTE: 30 watts maximum total (all three outputs)</i> |
| <b>Output Voltage</b>        | <b>5 VDC:</b> 5.0 VDC to 5.2 VDC (5.1 VDC nominal)<br><b>24 VDC Relay:</b> 24 to 28 VDC<br><b>24 VDC Isolated:</b> 21.5 VDC to 28 VDC  |
| <b>Protective Limits</b>     |  |
| <b>Overvoltage:</b>          | <b>5 VDC output:</b> 6.4 to 7 V  |
| <b>Overcurrent:</b>          | <b>5 VDC output:</b> 4 A maximum   |
| <b>Holdup Time:</b>          | 14 ms minimum  |
| <b>Standards</b>             | Refer to data sheet, GFK-0867B, or later version for product standards, and general specifications.  |

### Calculating Input Power Requirements for IC693PWR328

The following graph is a typical 48 VDC power supply efficiency curve. A basic procedure for determining efficiency of the 48 VDC power supply follows the figure.

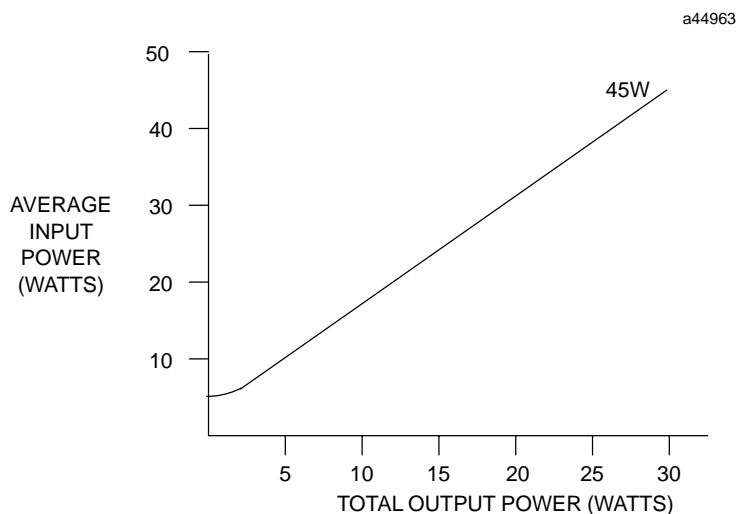

Figure 4-7. Typical Efficiency Curve for IC693PWR328 Power Supply

#### Note

Start-up surge at full load is 4 amps for 250 milliseconds (maximum).

### **Input Power/Current Calculation for IC693PWR328 Power Supply**

- Determine total output load from typical specifications listed for individual modules in Chapter 12.
- Use the graph to determine average input power.
- Divide the input power by the operating source voltage to determine the input current requirements.
- Use the lowest input voltage to determine the maximum input current.
- Allow for start-up surge current requirements.
- Allow margins (10% to 20%) for variations.

## IC693PWR331 High Capacity Power Supply, 24 VDC Input

The Series 90-30 DC input High Capacity power supply (IC693PWR331) is a 30 watt wide range supply designed for 24 VDC nominal inputs. *For applications requiring greater +5V current capacity than is available with the standard supply, this supply allows all 30 watts to be consumed from the +5 V output.* It will accept an input voltage range from 12 VDC to 30 VDC. Although it is capable of maintaining all outputs within specifications with input voltages as low as 12 VDC, it will not start with initial input voltages of less than 18 VDC. This power supply provides the following outputs:

- + 5 VDC output.
- + 24 VDC "Relay" power output which provides power to circuits on Series 90-30 Output Relay modules.
- "Isolated" +24 VDC, which is used internally by some modules, can also be used to provide external power for 24 VDC Input modules.

The load capacity for each output of this power supply is shown in the following table.

Table 4-10. IC693PWR331 Power Supply Capacities

| Catalog Number | Load Capacity | Input        | Output Capacities (Voltage/Power †) |                              |                           |
|----------------|---------------|--------------|-------------------------------------|------------------------------|---------------------------|
| IC693PWR331    | 30 Watts      | 12 to 30 VDC | +5 VDC<br>30 watts                  | +24 VDC Isolated<br>20 watts | +24 VDC Relay<br>15 watts |

† Total of all outputs combined cannot exceed 30 watts.

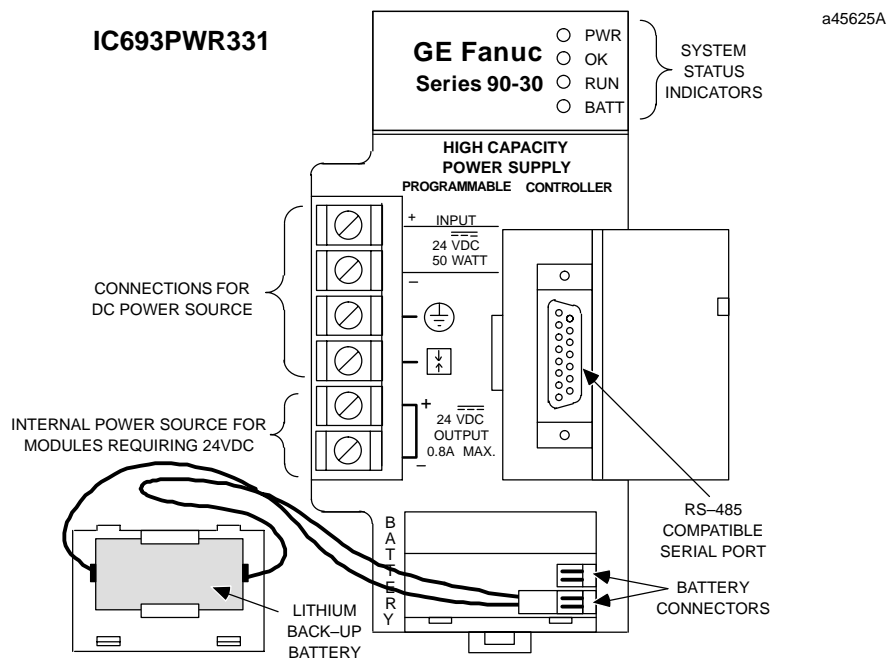

Figure 4-8. Series 90-30 24 VDC Input High Capacity Power Supply - IC693PWR331

Table 4-11. Specifications for IC693PWR331 Power Supply

|                              |   |
|------------------------------|---|
| <b>Nominal Rated Voltage</b> | 24 VDC  |
| <b>Input Voltage Range</b>   | 18 to 30 VDC  |
| <b>Start</b>                 | 18 to 30 VDC  |
| <b>Run</b>                   | 12 to 30 VDC  |
| <b>Input Power</b>           | 50 watts maximum at full load   |
| <b>Inrush Current</b>        | †   |
| <b>Output Power</b>          | 5 VDC: 30 watts maximum ‡<br>24 VDC Relay: 15 watts maximum<br>24 VDC Isolated: 20 watts maximum<br><i>NOTE: 30 watts maximum total (all three outputs)</i> |
| <b>Output Voltage</b>        | 5 VDC: 5.0 VDC to 5.2 VDC (5.1 VDC nominal)<br>24 VDC Relay: 19.2 to 28.8 VDC<br>24 VDC Isolated: 19.2 VDC to 28.8 VDC                                      |
| <b>Protective Limits</b>     |   |
| <b>Overvoltage:</b>          | 5 VDC output: 6.4 to 7 V  |
| <b>Overcurrent:</b>          | 5 VDC output: 7 A maximum   |
| <b>Holdup Time:</b>          | 10 ms minimum   |
| <b>Standards</b>             | Refer to data sheet, GFK-0867B, or later version for product standards, and general specifications.   |

† Dependent on installation and power supply impedance characteristics.

‡ Derate per Figure 2-22 at ambient temperatures above 50 C (122 F).

### Current Derating for Higher Temperatures

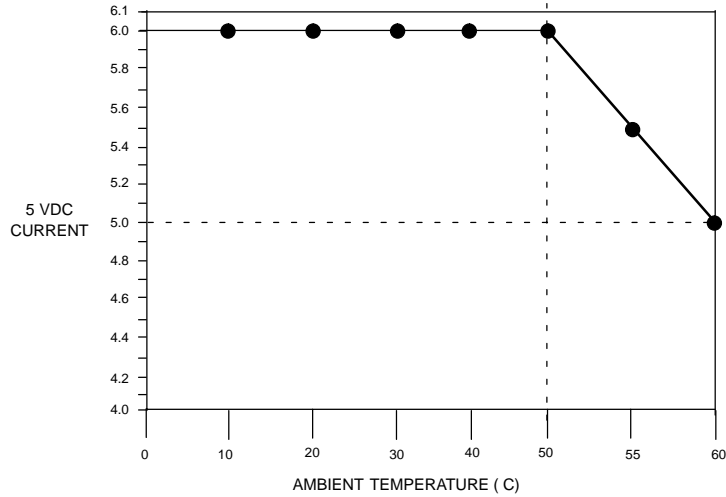

Figure 4-9. 5 VDC Current Output Derating for Temperatures above 50C (122F)

## Calculating Input Power Requirements for IC693PWR331

Use the following procedure to determine input power requirements for the 24 VDC High Capacity Power Supply:

- Determine total output power load from typical specifications listed for individual modules at the end of this chapter.
- Multiply the output power by 1.5 to determine the input power value.
- Divide the input power value by the operating source voltage to determine the input current requirements
- Use the lowest input voltage to determine the maximum input current
- Allow for start-up surge current requirements
- Allow margins (10% to 20%) for variations

## Field Wiring Connections to the DC Input-Only Power Supplies

### DC Power Source Connections

The + and - wires from the DC power source connect to the top two terminals on the terminal strip. The + wire should be connected to the top terminal screw, and the - wire to the second screw (counting from the top down). The ground connection connects to the third screw. This connection scheme is clearly marked on the front of these power supplies.

### Isolated 24 VDC Supply Output Connections

The bottom two terminals of the power supply terminal strip provide connections to the Isolated +24 volt DC output which can be used to provide power for external circuits (within power limitations of the supply).

#### Caution

**If the Isolated 24 VDC supply is overloaded or shorted, the Programmable Logic Controller will stop operation.**

## Common Series 90-30 Power Supply Features

### Status Indicator Lights on all Power Supplies

Four LEDs are located on the upper right front of the power supply faceplate. The purpose of these LEDs is as follows:

#### **PWR**

The top green LED, labeled **PWR**, provides an indication of the operating state of the power supply. The LED is *ON* when the power supply has a correct source of power and is operating properly, and *OFF* when a power supply fault occurs or power is not applied.

#### **OK**

The second green LED, labeled **OK**, is steady *ON* if the PLC is operating properly, and *OFF* if a problem is detected by the PLC.

#### **RUN**

The third green LED, labeled **RUN**, is steady *ON* when the PLC is in the RUN mode.

#### **BATT**

The bottom red LED, labeled **BATT**, will be *ON* if the memory backup battery voltage is too low to maintain the memory under a loss of power condition; otherwise it remains *OFF*. If this LED is *ON*, the Lithium battery must be replaced before removing power from the rack, or PLC memory may be lost.

### Input Overvoltage Protection Devices

**This information applies to all Series 90-30 power supplies except IC693PWR322 and IC693PWR328.** The overvoltage protection devices for this power supply are connected internally to pin 4 on the user terminal strip. This pin is normally connected to frame ground (pin 3) with the supplied jumper strap which is installed at the factory. If overvoltage protection is not required *or* is supplied upstream, this feature can be disabled by removing the jumper strap from pins 3 and 4.

If you want to Hi-pot test this supply, overvoltage protection *must be disabled* during the test by removing the terminal strip jumper strap. Re-enable overvoltage protection after testing by reinstalling the strap.

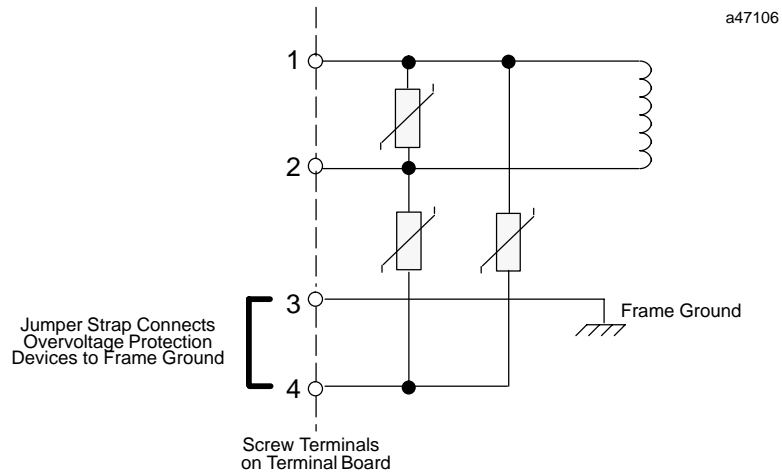

Figure 4-10. Overvoltage Protection Devices and Jumper Strap

### Output Voltage Connections to Backplane (All Supplies)

The following figure illustrates how these three output voltages are connected internally to the backplane on the baseplate. The voltage and power required by modules installed on the baseplate is supplied through the baseplate connectors.

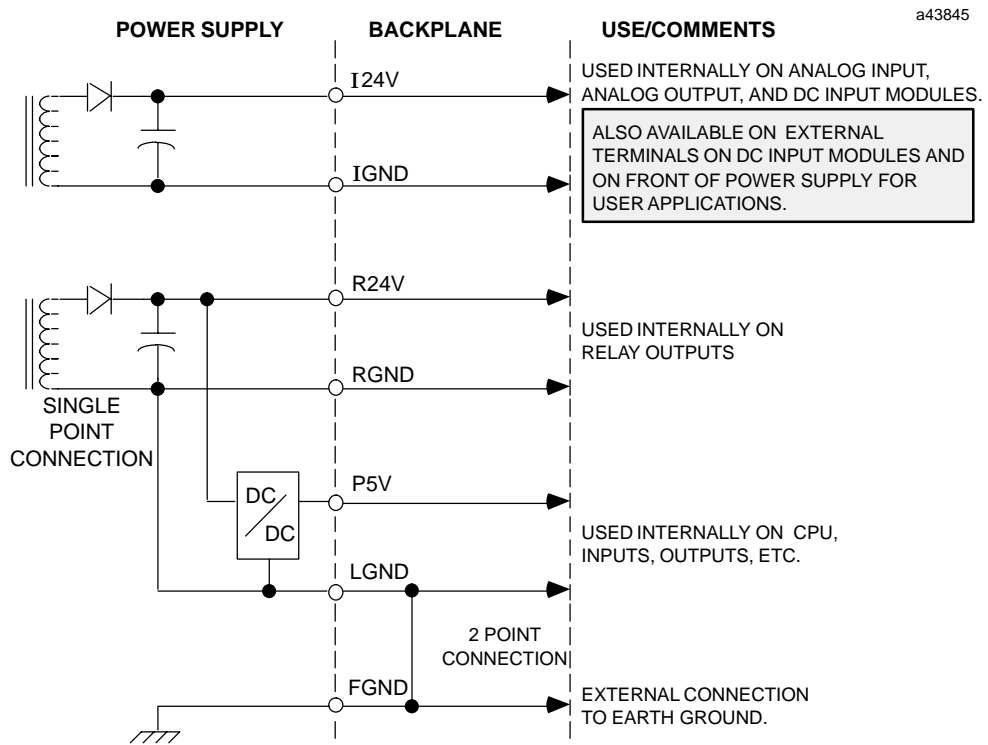

Figure 4-11. Interconnection of Power Supplies

## Overcurrent Protection (all Supplies)

The 5V logic output is electronically limited to 3.5 amps (7 amps for high capacity supplies). An overload (including short circuits) is sensed internally and causes the supply to shut down. The supply will continually try to restart until the overload is removed. An internal fuse in the input line is provided as a backup. The supply will usually shut down before the fuse blows. The fuse also protects against internal supply faults.

## Timing Diagram

The timing diagram below shows the relationship of the DC input to the DC outputs and to the Power Supply OK signal (PSOK) generated by the power supply. When power is first applied, the PSOK signal goes false. This line remains false for a minimum of 20 msec after the +5V bus is within specifications, then it becomes true.

If input power is interrupted, the +5V bus will remain within specifications and PSOK will remain true a minimum of 10 milliseconds. PSOK then goes false. The +5V bus will remain within specifications for an additional 4 milliseconds minimum to allow an orderly shutdown of the system.

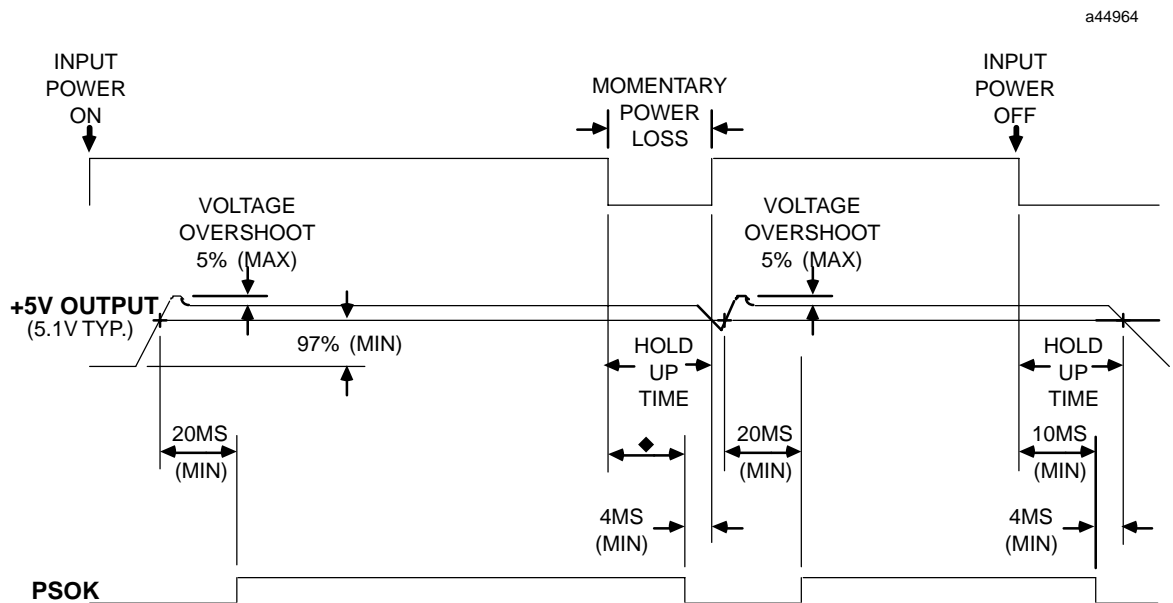

◆ HOLD-UP TIME: 20 ms, minimum for IC693PWR321/330  
14 ms, minimum for IC693PWR322  
10 ms, minimum for IC693PWR331/332

Figure 4-12. Timing Diagram for all Series 90-30 Power Supplies

## CPU Serial Port Connector on Power Supply (All Supplies)

A 15-pin D-type female connector, accessed by opening the hinged door on the right front of the power supply, provides the connection to a CPU serial port which is used to connect to:

- A programmer (usually a personal computer) running GE Fanuc PLC programming software.
- The GE Fanuc Hand-Held Programmer.
- Other serial devices.

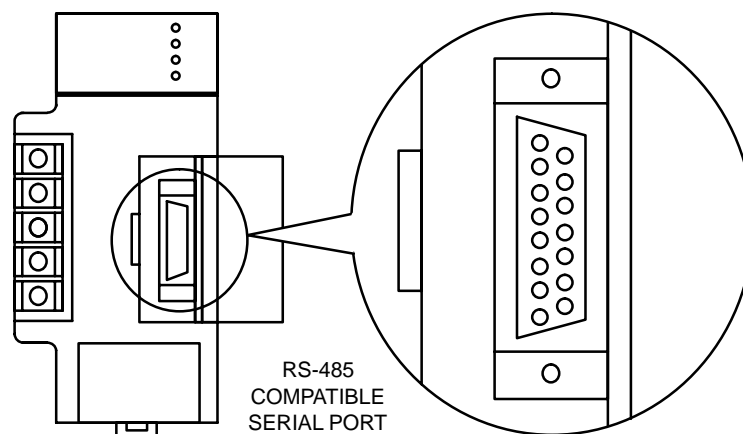

Figure 4-13. Serial Port Connector

- The serial port connector is only functional in a power supply that is installed in a baseplate that also contains the CPU. *The serial port is not functional on a power supply that is installed in an expansion or remote baseplate.*
- Any device connected to the serial port that uses +5 VDC power from the Series 90-30 power supply **must be included** in the calculation for maximum power consumption (see the heading “Power Supply Loading Calculations” in Chapter 12).

### CPU Serial Port Information

The serial port connector on the power supply accesses the CPU serial port, which is a feature of all Series 90-30 CPUs. See Chapter 5, “CPUs” for information on this serial port.

## Backup Battery for RAM Memory (All Supplies)

The long-life Lithium battery (IC693ACC301) used to maintain the contents of the CMOS RAM memory in the CPU is accessed by removing the cover plate located at the bottom of the power supply faceplate. This battery is mounted on a plastic clip attached to the inside of this cover.

The battery is wired to a small Berg female connector that connects to either of the two Berg male connectors mounted on the Power Supply printed circuit board. This battery can be replaced with power applied to the PLC.

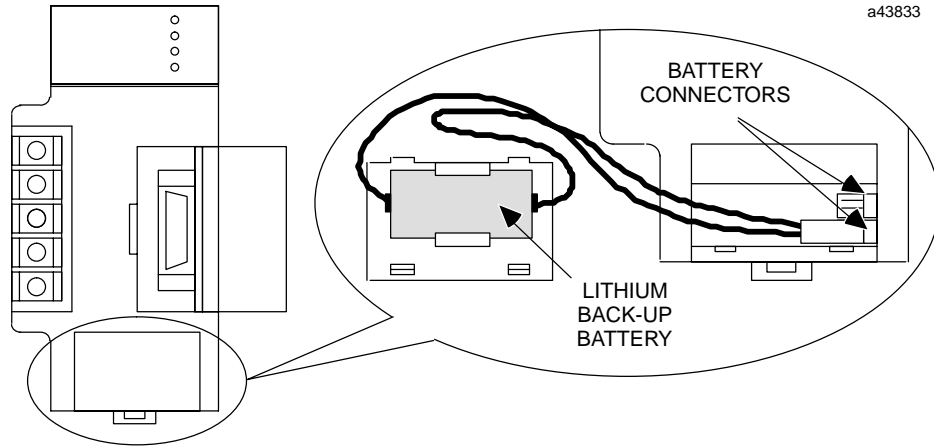

Figure 4-14. Backup Battery for RAM Memory

**Caution**

If a Low Battery Warning (BATT LED turns ON) occurs, replace the battery located in the power supply *before* removing power from the rack. Otherwise, there is a possibility that data will be corrupted or the application program will be cleared from memory.

**Additional Battery Information**

For additional information on the memory backup battery, see the chapter, “Memory Backup and Backup Battery.”

### CPU Types for Series 90-30 PLCs

There are numerous CPU models available for the Series 90-30 PLC which differ in speed, I/O capacity, size of user memory, and advanced features. This variety of models gives a system designer considerable flexibility in choosing the one best suited to the system being designed. There are two basic types of CPUs, **Embedded** and **Modular**. The embedded types fulfill the need for a good low cost PLC, but lack the power, expandability, and versatility of the modular systems. In the embedded types, the CPU is built into the baseplate. In the modular types, the CPU is contained inside a plug-in module.

#### Embedded CPUs

The embedded CPUs are part of an embedded CPU baseplate. In these products, the CPU and memory integrated circuit chips are soldered to the backplane board of the baseplate. This chapter discusses the CPU features of these products. Details about the baseplate features are located in Chapter 2. There are three different embedded CPUs: Model 311 (IC693CPU311), Model 313 (IC693CPU313), and Model 323 (IC693CPU323). The embedded CPUs have the following basic features:

- The CPU type cannot be changed. It is soldered to the backplane board in the baseplate.
- They do not support the use of Expansion or Remote racks, so an embedded CPU baseplate does not have an expansion connector like the modular baseplates do. This means that if you have an application that requires more than 10 modules, you will have to use a modular CPU system.
- The models 311 and 313 are 5-slot baseplates, and the model 323 is a 10-slot baseplate. Since they do not require a plug-in CPU module, all numbered slots, including Slot 1, can be used for I/O or Option modules.
- The memory back-up battery is located in the Power Supply module; so if the Power Supply is unplugged from the baseplate, the battery will be disconnected from the memory circuits, which are located on the backplane circuit board. However, the backplane circuit board contains a high value capacitor, called a "super capacitor," that can store enough charge to maintain the memory circuits for a short period of time if the Power Supply is removed or its battery is disconnected. See the section "Super Capacitor Memory Backup" in Chapter 6.
- These CPUs do not have a time-of-day (TOD) clock.

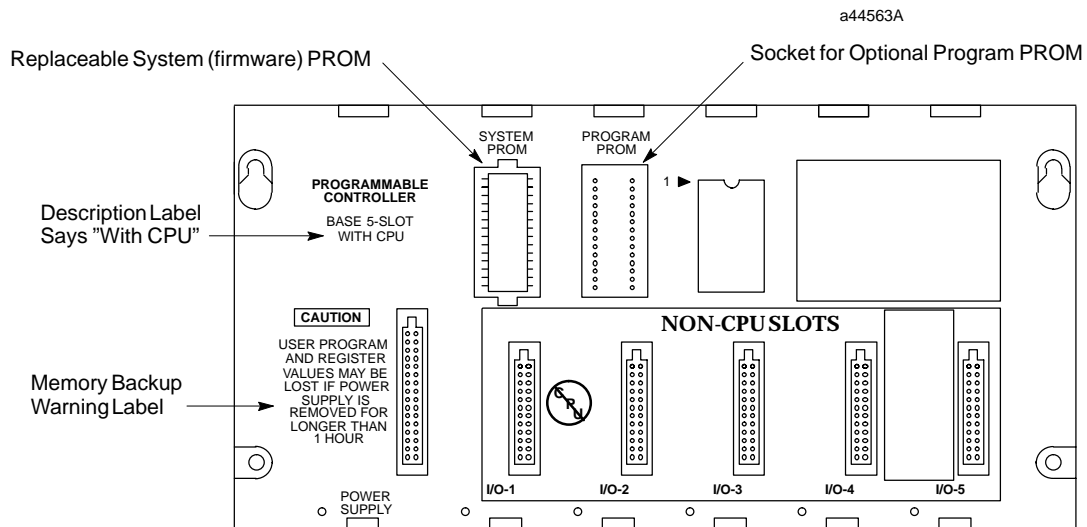

Figure 5-1. Models 311 and 313 (5-Slot) Embedded CPU Baseplates

## Modular CPUs

The modular CPUs consist of a CPU, memory, and associated integrated circuit chips soldered to circuit board which is mounted in a plug-in module. The modular CPUs include the model CPU331 and higher. The modular CPUs have the following basic features:

- A CPU module must be installed in Slot 1 of a modular CPU baseplate. Slot 1 is a unique size and type that only fits a CPU module (or special Option modules). Slot 1 is labeled CPU/1. Details on modular CPU baseplates are located in Chapter 2.
- Modular CPUs support expansion and remote baseplates, so a 25-pin D-type female expansion connector is located at the right end of the CPU baseplate for connection to an expansion or remote baseplate.
- Since the CPU is modular, it can readily be replaced or changed to a different type if desired.
- Only one CPU is allowed per system, and it must be mounted in a CPU baseplate. If more than one baseplate is used in a system, the additional ones must be either expansion or remote types that do not contain a CPU.
- A modular CPU baseplate is always assigned, by default, Rack Number 0.
- All have a time-of-day (TOD) clock.

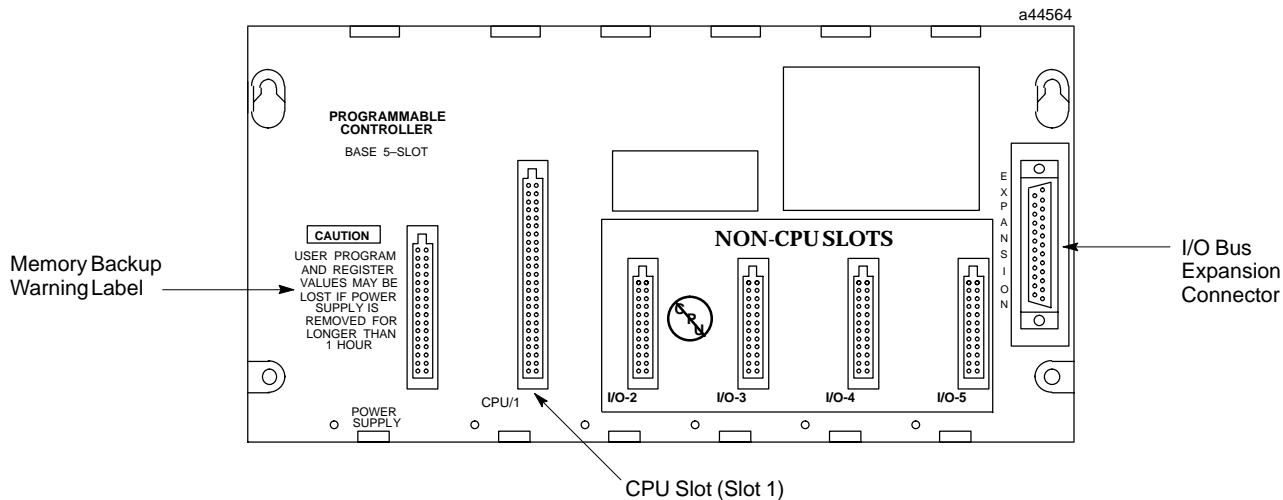

Figure 5-2. IC693CHS397 5-Slot Modular CPU Baseplate

## General CPU Features

### Microprocessor

The microprocessor type varies by the CPU model:

- 80188 microprocessor for CPU models 311/313/323/331
- 80C188XL microprocessor for CPU models 340/341
- 80386EX microprocessor for CPU models 350–364.

The microprocessor provides all fundamental sweep and operation control, and execution of all non-boolean (as used here, the term boolean refers to discrete logic such as contacts and coils) functions. Boolean functions in the modular CPUs are handled by a dedicated VLSI (Very Large Scale Integration) Instruction Sequencer Coprocessor (ISCP). All Series 90-30 CPUs use RAM working memory.

### CPU Serial Port (Connector on Power Supply)

A 15-pin D-type female connector, accessed by opening the hinged door on the right front of the power supply, provides the connection to a CPU serial port which is used to connect to:

- A programmer (usually a personal computer) running GE Fanuc PLC programming software. The IC690ACC901 Miniconverter/cable kit is a convenient way to access this port. See Appendix F for details.
- The IC693PRG300 GE Fanuc Hand-Held Programmer. See Chapter 11 for details.
- Other serial devices.

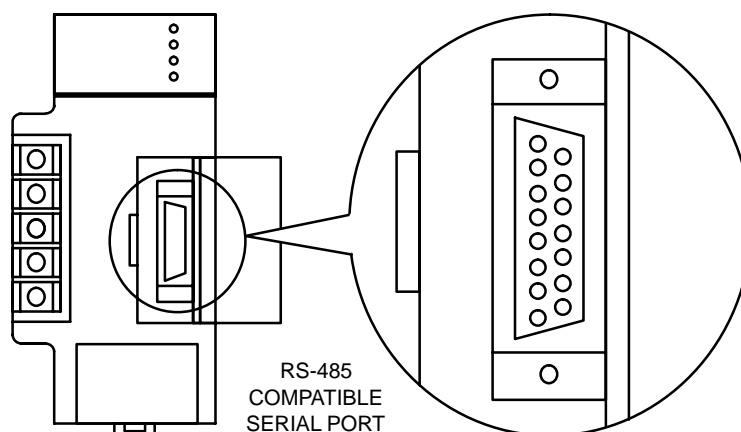

Figure 5-3. CPU Serial Port Connector on Power Supply

- This serial port is RS-485 compatible, and uses the GE Fanuc SNP (Series Ninety Protocol) protocol (slave only). Break-Free SNP became the default protocol on all serial ports on the Series 90-30 CPUs, starting with Firmware Release 9.00 for CPUs 350 - 364, and Firmware Release 8.20 for CPUs 311 - 341. BreakFree SNP is discussed in a later section of this chapter.
- The serial port connector is only functional in a power supply that is installed in a baseplate that also contains the CPU. It is not functional on a power supply that is installed in an expansion or remote baseplate.
- Any device connected to the serial port that uses +5 VDC power from the Series 90-30 power supply **must be included** in the calculation for maximum power consumption (see the heading “Power Supply Loading Calculations” in Chapter 12).
- All Series 90-30 CPUs have this serial port arrangement. The 351, 352, and 363 CPUs have additional serial ports, described in a later section of this chapter.

### Caution

**Care must be taken that common mode voltage specifications are met for connections to this serial port. Common mode conditions that exceed those specified will result in errors in transmission and/or damage to Series 90 PLC components. Common mode specifications are discussed in Appendix C. When the common mode voltage specification is exceeded, a port isolator such as the GE Fanuc IC690ACC903 must be used. See Appendix G for details on this port isolator.**

## Memory Volatility

The term volatility refers to the issue of whether or not a certain memory type retains or loses its contents (data) when power is removed from it.

- **Volatile** memory – memory that loses its contents when power is removed. RAM memory is inherently volatile. Therefore, when the PLC is turned off, a backup battery is necessary if data loss in RAM memory is to be prevented.

- **Non-volatile** memory – memory that retains its contents when power is removed. The various types of PROM (Programmable Read-Only Memory) memory are non-volatile.

## RAM Memory

Every Series 90-30 CPU uses RAM memory for its "working memory." The RAM chips used are of the CMOS type. CMOS RAM is an acronym for **Complimentary Metal-Oxide Semiconductor, Random Access Memory**. CMOS RAM is a relatively fast, low power memory that can be easily examined (read) and changed (written to).

In the embedded CPU models, RAM memory is mounted on the backplane board. In the modular CPU models, RAM memory is mounted inside the CPU module. A backup battery is usually used to preserve the contents of RAM memory when power is off.

## RAM Memory Backup/Backup Battery Information

Please see Chapter 6 for the following information:

- RAM memory backup recommendations.
- Backup battery information such as estimated life, replacing, determining battery age using date codes, etc.
- Running without a backup battery.
- Low battery warning methods.

## Programmable Read-Only Memory (PROM) Types

There are three types of PROM devices used in Series 90-30 CPUs:

**EPROM:** An acronym for Erasable Programmable Read-Only Memory. It is a plug-in integrated circuit memory device that can be erased with an ultraviolet light. EPROMs can be read when installed in the PLC, however in order to write new data to them, they must be removed from the PLC and written to using an external PROM burning device.

**EEPROM:** An acronym for Electrically Erasable Programmable Read-Only Memory. It is a plug-in integrated circuit memory device that can be erased and written to while installed in the PLC.

**Flash Memory:** A variation of the EEPROM type memory. It also is an integrated circuit device that can be erased and written to while installed in the PLC. One advantage of CPUs having flash memory storage of firmware, is that firmware can be updated by writing from a Personal Computer through a PLC serial port to flash memory. No modules have to be removed for flash firmware upgrade.

## Uses of PROM devices in the 90-30 CPUs

PROM-type devices are used in two ways in the 90-30 CPUs:

- To store CPU firmware
- To store user data, which consists of program, configuration, and register data.

The following table shows the types of PROM devices each CPU uses.

## CPU Firmware and PROM Configurations

| CPU Firmware and PROM Table |                     |                         |                          |                         |
|-----------------------------|---------------------|-------------------------|--------------------------|-------------------------|
| CPU                         | Firmware (standard) | EPROM (for user memory) | EEPROM (for user memory) | Flash (for user memory) |
| CPU311                      | EPROM               | Optional                | Optional                 | N/A                     |
| CPU313                      | EPROM               | Optional                | Optional                 | N/A                     |
| CPU323                      | EPROM               | Optional                | Optional                 | N/A                     |
| CPU331                      | EPROM               | Optional                | Optional                 | N/A                     |
| CPU340                      | EPROM               | N/A                     | N/A                      | Optional                |
| CPU341                      | EPROM               | *Optional               | * Optional               | *Optional               |
| CPU350                      | Flash               | N/A                     | N/A                      | Standard                |
| CPU351                      | Flash               | N/A                     | N/A                      | Standard                |
| CPU352                      | Flash               | N/A                     | N/A                      | Standard                |
| CPU360                      | Flash               | N/A                     | N/A                      | Standard                |
| CPU363                      | Flash               | N/A                     | N/A                      | Standard                |
| CPU364                      | Flash               | N/A                     | N/A                      | Standard                |

\* Early versions of the CPU341 support optional EPROM and optional EEPROM only. Starting with hardware version IC693CPU341-J and Firmware version 4.61, only optional Flash is supported.

### CPU Firmware

The CPU firmware contains the basic operating instructions for the PLC. Firmware is developed by a GE Fanuc product engineering group. It is stored in either EPROM or Flash memory, depending on the particular CPU.

### CPU Firmware Upgrade (Update)

From time to time, new firmware is released. A new firmware version may contain support for new features or improvements to existing features. Once a new version of CPU firmware is released, all new CPU modules will be sold with that version. The Technical Support section of the GE Fanuc Web site lists CPU revision histories, matching version numbers to associated features. See Chapter 13 for information on the GE Fanuc Web site. Users who could benefit from a new firmware release may choose to upgrade their CPU by installing new firmware. Upgrades come in two formats, depending on the type of CPU to be upgraded. The "CPU Firmware and PROM Configuration" table in this chapter shows which type of firmware storage device each CPU has. The two types are:

- **EPROM** – For CPUs with firmware stored in EPROM, the upgrade is done by replacing the CPU's EPROM chip(s). The upgrade kit contains new EPROM chip(s), update labels, and installation instructions. To upgrade the EPROM in an embedded CPU system, the module in slot 1 must be unplugged to gain access to

the PROM socket on the baseplate. In the case of a modular CPU, the CPU must be unplugged and disassembled.

- **Flash** – For CPUs with firmware stored in Flash, the upgrade is done by copying a new firmware file to the CPU's Flash memory. An upgrade kit may be purchased from GE Fanuc. The upgrade kit contains the necessary files, update labels, and instructions. This method does not require disassembling the module. The file downloading is done either through the port on the power supply, or through a port on the front of the CPU module (if it has one). The applicable method will be documented in your upgrade kit instructions. Downloadable firmware upgrade files are also found in the Technical Support area of the GE Fanuc Web site. See Chapter 13 for Web site information.

To order an upgrade kit, write down the full catalog number of your module from the module identification label on the side of the module, determine your current firmware revision level, then call your PLC distributor. If you are not sure what firmware version you currently have, see the heading on the next page "Determining CPU Revision Levels (Versions)."

### Flash Firmware Upgrade Procedure

The operating system firmware is updated by connecting a PC compatible computer to the applicable PLC serial port and running the PC Loader software included with the firmware floppy disk.

The computer used for this task should be an IBM AT compatible or better PC with a minimum 640K of RAM, one 3.5" or high density 5.25" floppy drive, MS-DOS version 3.3 or later, a hard drive, and an RS-232 serial port. In addition, a miniconverter/serial cable is required. The following miniconverter/serial cable kit is available:

- IC690ACC901 Miniconverter Kit (RS-232/RS-485) with cable and 9-pin to 25-pin adapter. (This product is documented in Appendix F)

### Determining CPU Revision Levels (Versions)

If you plan to make changes to your system, you will need to know if your CPU can support those changes. The features and capabilities of your CPU are determined by its revision levels (hardware and firmware). This section discusses methods that you can use to determine your CPU's revision levels and associated features and capabilities.

#### Direct Methods

- Obtain the information from the Important Product Information (IPI) sheet that came with your CPU. However, if your CPU firmware has been upgraded, the IPI will not indicate the current revision level.
- The surest way to determine a CPU's firmware revision level is to read it from the CPU by using your programmer. Your programmer must be connected to the PLC and be in Online or Monitor mode, and the PLC must be powered up. For example, on the LogiMaster "PLC STATUS and CONTROL" screen is an item called "SOFTWARE REVISION." The data displayed in that field (such as 6.04) is the firmware revision level. See the *LogiMaster 90-30 Programming Software User's Manual*, GFK-0466 (or the user's manual for the programming software you use), for additional details.

### Indirect Method

Check the catalog number printed on the module identification label on the side of the module. On all Series 90-30 modules, this catalog number indicates the module's revision level(s). For some CPUs, the catalog number contains a single letter at the end to indicate the CPU's overall revision level. For example,

IC693CPU341-J

This tells us that the module has a revision level J. Later CPU modules began to be produced with two revision letters, such as:

IC693CPU351-EK

The first letter stands for the hardware revision level and the second for the firmware revision level.

These letters can be cross-referenced to the firmware version. A revision history list for Series 90-30 products, including CPUs, can be found in the GE Fanuc web site technical support area ([www.gefanuc.com/support](http://www.gefanuc.com/support)) that cross-references revision letters, firmware versions, and related features. Also, if you have access to the progression of IPIs that were issued for the particular CPU (these are available on the GE Fanuc PLC InfoLink CD-ROM) you can find the desired cross-reference. Of course, you can also contact your distributor or GE Fanuc for help.

If your firmware has been upgraded in the past, a small label that comes in the upgrade kit should be attached to the side of the module next to the module identification label to indicate the current firmware revision level. However, the label could have been forgotten; so to be sure, you may want to read the information from the CPU with a programmer as described in the "Direct Method" above. On models with EPROM firmware, the firmware revision level will also be printed on the EPROM.

### EPROM and EEPROM User Program Storage Options

The Model 311, 313, 323, 331, and an earlier version of the Model 341 CPUs have a **User PROMoption** for storing user application programs, register data, and configuration data in non-volatile memory. Application programs are usually developed in a CPU's battery-backed RAM memory and executed from this RAM memory. But, if additional program integrity, or operation of the PLC without a battery is desired, an optional EEPROM or EPROM can be installed in a spare socket (labeled PROGRAM PROM) on the embedded CPU baseplates or in a socket inside the Model 331 CPU module (and inside the early versions of Model 341 CPU prior to hardware version IC693CPU341-J and firmware release 4.61). The Model 331 CPU module (and the early versions of Model 341) has a jumper labeled **JP1** located next to the EEPROM/EPROM socket to allow you to select either *EEPROM* or *EPROM*. These jumper positions are shown below.

| Jumper | Selects |
|--------|---------|
| 3 - 2  | EEPROM  |
| 2 - 1  | EPROM   |

## Comparing EPROM and EEPROM Features

For one-time applications, an EEPROM is the more practical of the two. It can be created in the PLC itself and doesn't require any additional outside equipment. An EPROM is not as convenient to create. It must be created outside the PLC using an EPROM burner. However, an EPROM is less expensive than an EEPROM. So, if you need to reproduce multiple copies of a program to use on a large number of identical controls, it may be cost effective to use EPROMs, especially if you already have an EPROM burner.

## Procedure for Creating an EPROM

These are the steps for creating an EPROM or multiple EPROMs:

- Install an EEPROM in the PROM socket of the PLC you will use to develop the application program.
- Develop and debug the program in RAM memory, then write it to the EEPROM.
- Remove the EEPROM from the PLC and install it in the EPROM burner as a master to make one or more EPROMs.
- Install the blank EPROM in the EPROM burner and copy the program on the EEPROM to the blank EPROM.
- Install the EPROM in the PLC's PROM socket, then copy its contents into RAM memory. The EPROM then serves as an on-board backup to RAM memory.

Note: Your CPU can be configured to load the the application program stored in the PROM device automatically into RAM memory when the CPU is powered-up. See the heading "Running Without a Memory Backup Battery" in Chapter 6 for details.

### Caution

**If PROM is configured (on the CPU configuration screen) as the power-up program source and a PROM device is not present in the PROM socket, or a blank PROM is in the socket, on a power-up cycle, a blank program will be copied into the CPU's RAM memory and the program in RAM memory will be lost. Always keep a backup copy of your current program files in case of an emergency.**

EEPROM and EPROM memory devices are available from GE Fanuc. Catalog numbers for these devices are listed in the following table.

Table 5-1. EPROM and EEPROM Catalog Numbers

| CatalogNumber       | Description           | GE Fanuc PartNumber | Third Party Source Vendor PartNumber  |
|---------------------|-----------------------|---------------------|---|
| IC693ACC305 (Qty 4) | 28C256 EEPROM, 350ns  | 44A725999-000       | XICOR X28C256P<br>XICORX28C256P25<br>XICORX28HC256P-15  |
| IC693ACC306 (Qty 4) | 32Kx8 UV EPROM, 150ns | 44A723379-000       | NEC PD27C256AD-15<br>Atmel AT27C256-15DC1<br>Toshiba TC57256AD-15<br>Hitachi HN27C256AG-15<br>AMD AM27C256-150DC<br>Intel TD27C256A-1 |

## Flash Memory

The Model 340, 341 (later versions), 350, 351, 352, 360, 363, and 364 CPUs have **Flash memory** for user program storage. (Note that versions of the Model 341 CPU prior to firmware release 4.61 had EEPROM memory.) The Read/Write/Verify process for user programs is the same for Flash memory as it is for EEPROM operations. Flash memory operations (Read, Write, or Verify) are accessed from the Program Utilities Function menu or from another Program Utilities screen in the Logicmaster 90-30/20/Micro programming software.

## Series 90-30 CPU Capacities

The following table describes the maximum capacities and operating features for the Series 90-30 PLC CPU models. For State Logic CPUs, see the section “System Specifications for Series 90-30 State Logic CPUs” in Chapter 9.

**Table 5-2. Series 90-30 CPU Capacities**

| CPU Model | Speed, (MHz) | Processor | Input Points     | Output Points    | Register Memory | User Program Memory (Maximum) | Floating Point Math |
|-----------|--------------|-----------|------------------|------------------|-----------------|-------------------------------|---------------------|
| CPU311    | 10           | 80188     | 160 <sup>1</sup> | 160 <sup>1</sup> | 1K (Bytes)      | 6K (Bytes)                    | no                  |
| CPU313    | 10           | 80188     | 160 <sup>1</sup> | 160 <sup>1</sup> | 2K (Bytes)      | 12K (Bytes)                   | no                  |
| CPU323    | 10           | 80188     | 320 <sup>2</sup> | 320 <sup>2</sup> | 2K (Bytes)      | 12K (Bytes)                   | no                  |
| CPU331    | 10           | 80188     | 512              | 512              | 4K (Bytes)      | 16K (Bytes)                   | no                  |
| CPU340    | 20           | 80C188XL  | 512              | 512              | 19.9K (Bytes)   | 32K (Bytes)                   | no                  |
| CPU341    | 20           | 80C188XL  | 512              | 512              | 19.9K (Bytes)   | 80K (Bytes)                   | no                  |
| CPU350    | 25           | 80386EX   | 2048             | 2048             | 19.9K (Bytes)   | 32K (Bytes)                   | yes                 |
| CPU351    | 25           | 80386EX   | 2048             | 2048             | Note 3          | Note 4                        | yes                 |
| CPU352    | 25           | 80386EX   | 2048             | 2048             | Note 3          | Note 4                        | yes <sup>5</sup>    |
| CPU360    | 25           | 80386EX   | 2048             | 2048             | Note 3          | Note 4                        | yes                 |
| CPU363    | 25           | 80386EX   | 2048             | 2048             | Note 3          | Note 4                        | yes                 |
| CPU364    | 25           | 80386EX   | 2048             | 2048             | Note 3          | Note 4                        | yes                 |

- <sup>1</sup> Maximum of 160 combined I + O points.
- <sup>2</sup> Maximum of 320 combined I + O points.
- <sup>3</sup> Configurable from 128 to 32,640 words, in 128 word increments.
- <sup>4</sup> Depends on assigned values for configurable word memory (%R, %AQ, %AI). Maximum is 240K Bytes.
- <sup>5</sup> CPU352 has hardware-based floating point math. Others CPUs have firmware-based floating point math.

## User Memory Addresses (References)

Data in the Series 90-30 PLC programs is referenced by its memory address. A reference indicates the way that data is stored in the PLC. A reference specifies both a memory type and a precise location (number) within that memory type. For example:

%I00001      specifies address 1 in input memory.  
 %R00256      specifies address 256 in register memory.

## Difference Between a Memory Address and a Nickname

The % symbol is used to distinguish memory addresses from nicknames. For example, %I17 (or %I000017) is a memory address. The similar term, I17 (it has no % sign), is viewed by the PLC as a nickname and could be used with most memory addresses. For example, if you had a motor in your plant called "Infeed No. 17," and it was commonly referred to as "I17" by the people in your plant, you might wish to use I17 as the nickname for the output coil (%Q11) that turns on that motor. You are allowed to do so because the PLC can distinguish between the nickname, I17 (your nickname for memory address %Q11), and memory address %I17.

## User Memory Reference Types

The user references referred to in the following tables are explained in the *Series 90-30 PLC CPU Instruction Set Reference Manual*, GFK-0467.

**Table 5-3. Range and Size of User References for CPU Models 311-341**

| Reference(Memory) Type     | Model311/313/323      |            | ModeB31/340/341   |   |
|----------------------------|-----------------------|------------|-------------------|---|
|                            | Reference Range       | Size       | Reference Range   | Size  |
| User program logic         | Not applicable        | 6K bytes   | Not applicable    | CPU331: 16K bytes<br>CPU340: 32K bytes<br>CPU341: 80K bytes |
| Discrete inputs            | %I0001 - %I0320 †     | 512 bits   | %I0001 - %I0512   | 512 bits  |
| Discrete outputs           | %Q0001 - %Q0320 †     | 512 bits   | %Q0001 - %Q0512   | 512 bits  |
| Discrete globals           | %G0001 - %G1280       | 1280 bits  | %G0001 - %G1280   | 1280 bits   |
| Internal coils             | %M0001 - %M1024       | 1024 bits  | %M0001 - %M1024   | 1024 Bits   |
| Temporary coils            | %T0001 - %T0256       | 256 bits   | %T0001 - %T0256   | 256 bits  |
| System status references   | %S0001 - %S0032       | 32 bits    | %S0001 - %S0032   | 32 bits   |
|                            | %SA001 - %SA032       | 32 bits    | %SA0001 - %SA0032 | 32 bits   |
|                            | %SB001 - %SB032       | 32 bits    | %SB0001 - %SB0032 | 32 bits   |
|                            | %SC001 - %SC032       | 32 bits    | %SC0001 - %SC0032 | 32 bits   |
| System register references | %R0001 - %R0512 (311) | 512 words  | %R0001 - %R2048   | 2K words (331)  |
|                            | %R0001 - %R1024 (313) | 1024 words | %R0001 - %R9999   | 9999 words (340/341)  |
| Analog inputs              | %AI001 - %AI064       | 64 words   | %AI0001 - %AI0128 | 128 words (331)   |
|                            |                       |            | %AI0001 - %AI1024 | 1024 words (340/341)  |
| Analog outputs             | %AQ001 - %AQ032       | 32 words   | %AQ001 - %AQ064   | 64 words (331)  |
|                            |                       |            | %AQ001 - %AQ256   | 256 words (340/341)   |
| System registers ‡         | %SR001 - %SR016       | 16 words   | %SR001 - %SR016   | 16 words  |

† 160 physical I/O maximum with 16 point modules installed; 320 maximum with 32 point modules installed

‡ May be viewed only with a Hand-Held Programmer (see the Hand-Held Programmer User's Manual, GFK-0402) ; may not be referenced in a user's logic program.

Table 5-4. Range and Size of User References for CPU Models 350 through 364

| Reference Type           | Model 350/351/352/360/363/364 CPU |  |
|--------------------------|-----------------------------------|--|
|                          | Reference Range                   | Size   |
| MaximumUser memory*      | Notapplicable                     | 240K Bytes, configurable<br>(CPU350: 32K Bytes, fixed)             |
| Discreteinputs           | %I0001 - %I2048                   | 2048 bits  |
| Discreteoutputs          | %Q0001 - %Q2048                   | 2048 bits  |
| Discrete globals         | %G0001 - %G1280                   | 1280 bits  |
| Internal coils           | %M0001 - %M4096                   | 4096 bits  |
| Temporary coils          | %T0001 - %T0256                   | 256 bits   |
| Systemstatusreferences   | %S0001 - %S0032                   | 32 bits  |
|                          | %SA001 - %SA032                   | 32 bits  |
|                          | %SB001 - %SB032                   | 32 bits  |
|                          | %SC001 - %SC032                   | 32 bits  |
| Systemregisterreferences | %R0001 - %R32640*                 | 128 - 32,640 words , configurable.<br>(CPU350: 9999 words, fixed,) |
| Analoginputs             | %AI001-%AI32640*                  | 128 - 32,640 words , configurable.<br>(CPU350: 2048 words, fixed)  |
| Analogoutputs            | %AQ001-%AQ32640*                  | 128 - 32,640 words,configurable.<br>(CPU350: 512 words, fixed)     |
| System registers †       | %SR001 - %SR028                   | 28 words   |

† May be viewed only with a Hand-Held Programmer (see the Hand-Held Programmer User’s Manual, GFK-0402) ; may not be referenced in a user’s logic program.

\* Depends on user-defined value(s) of configurable memory.

### Application Program Compatibility

Programs that have been developed on Series 90-30 CPUs 311–341 will automatically be translated by the programming software when used on CPUs 350–364. Programs created or translated for CPUs 350–364 will automatically be translated when used with CPUs 311–341; however, be aware that some CPUs support features, such as floating-point math or larger memory sizes, that are not supported by other CPUs. In those cases, attempting to load a program to a CPU not supporting one or more of the programmed or configured features will result in an error. However, in some cases it may be possible to edit the program and configuration to make them compatible with the targeted CPU.

### CPU Time-of-Day (TOD) Clock Accuracy

The accuracy of the Series 90-30 time-of-day clock is Ç 9 seconds per day across the rated operating temperature range of 0–60°C. The accuracy is relatively stable at any fixed temperature. For applications that require greater accuracy, the following suggestions are furnished:

- For an installation where the temperature of the CPU is stable, measure the amount of time drift for a 24 hour period, then program a “correction” factor into the ladder program to add or subtract seconds periodically to keep the CPU time accurate. The instruction to use in this case is Service Request #7, “Change/ReadTime-of-Day Clock.” At the appropriate time, a Service Request would read the TOD clock, an

ADD instruction would add the correction value to it, and another Service Request would write the new value to the TOD clock. A possible drawback to this method is that if you replace your CPU you will have to determine a new correction factor. Also, this method is affected by temperature changes, so its success is based on holding the CPU's ambient temperature stable.

- If more accuracy is needed, the PLC could be interfaced to a third party solution such as a radio link or Global Positioning System (GPS) satellite system.

## Break-Free SNP Protocol

Break-Free SNP became the default protocol on all serial ports on the Series 90-30 CPUs, starting with Firmware Release 9.00 for CPUs 350 - 364, and Firmware Release 8.20 for CPUs 311 - 341. The Break-Free feature makes the protocol compatible with a wider variety of modems. This feature is compatible with existing SNP master units such as computers running PLC programming software, or PCM modules. In a few applications, primarily where a combination of multi-drop SNP communications and very short PLC sweep times are used, users may desire, for performance reasons, to disable Break-Free SNP. Break-Free SNP can be disabled and re-enabled via Communications Request instructions. The Series 90 PLC Serial Communications User's Manual, GFK-0582D (when available) will document these Communications Request instructions. These instructions are currently detailed in Important Product Information (IPI) publication number GFK-0810W.

## 350 - 364 CPUs

The 350-364 group of CPUs was developed to meet the needs of customers requiring increased memory size, faster processing speed, and additional features not available on the 311-341 CPUs.

## Compatibility With Hand-Held Programmer (HHP) and Memory Card

- The user program in CPUs 350–364 **cannot** be viewed or edited with the Series 90-30 Hand-Held Programmer (IC693PRG300). You must use one of the GE Fanuc programming software packages to create or edit CPU 350–364 user programs.
- The Series 90 Memory Card (used on the Hand-Held Programmer) is *not supported* by CPUs 350–364.
- The only operations supported by the HHP's *PROGRAM* mode are writing to and reading from the CPU's flash memory.
- Although the HHP's *CONFIG* mode can be used to perform basic configuration of these CPUs, it cannot handle specialized parameters such as those pertaining to the embedded Ethernet Interface in the CPU364.
- The HHP can be used to change the Time-of-Day Clock unless the *Mem Protect* configuration parameter is set to *Enabled* and the keylock switch is in the ON (Protect) position.
- The HHP can be used to edit data values in %R registers.
- The HHP can be used to invoke or clear overrides on these CPUs.

## 350 - 364 CPU Advanced Features

| Advanced features of 350 - 364 CPUs |                             |                                |                                |                                |                                |                                |
|-------------------------------------|-----------------------------|--------------------------------|--------------------------------|--------------------------------|--------------------------------|--------------------------------|
| Feature                             | CPU350                      | CPU351                         | CPU352                         | CPU360                         | CPU363                         | CPU364                         |
| Memory                              | 32K fixed                   | 240K <sup>1</sup> Configurable | 240K <sup>1</sup> Configurable | 240K <sup>1</sup> Configurable | 240K <sup>1</sup> Configurable | 240K <sup>1</sup> Configurable |
| Serial Ports                        | 1                           | 3                              | 3                              | 1                              | 3                              | 1                              |
| Floating-Point Math                 | Yes <sup>1</sup> (Firmware) | Yes <sup>1</sup> (Firmware)    | Yes (Hardware)                 | Yes <sup>1</sup> (Firmware)    | Yes <sup>1</sup> (Firmware)    | Yes <sup>1</sup> (Firmware)    |
| Flash Memory                        | Yes                         | Yes                            | Yes                            | Yes                            | Yes                            | Yes                            |
| Key Switch                          | Yes                         | Yes                            | Yes                            | Yes                            | Yes                            | Yes                            |
| Sequential Event Recorder           | Yes <sup>1</sup>            | Yes <sup>1</sup>               | Yes <sup>1</sup>               | Yes <sup>1</sup>               | Yes <sup>1</sup>               | Yes <sup>1</sup>               |
| Embedded Ethernet Interface         | No                          | No                             | No                             | No                             | No                             | Yes <sup>1</sup>               |

<sup>1</sup> Denotes features supported in CPU firmware release 9.0 and later.

## Details of 350 - 364 CPU Advanced Features

### Upgrading Older CPUs

Older versions of the CPU firmware do not support some of the features in the table above (see table footnote). These features may be added to older 350 - 360 CPUs by upgrading them to CPU firmware version 9.0 or later. (The 363 and 364 CPUs were equipped with firmware version 9.0 when released as new products.) No hardware changes are required for this upgrade. For more information on the subject of upgrading, see the heading “CPU Firmware Upgrades” earlier in this chapter.

### Memory/Configurable Memory

Starting with CPU firmware version 9.0, the 351 - 364 CPUs have 240K of user-configurable memory. The CPU350 has 32K of fixed memory. The configurable memory feature lets you specify the amount of %R, %AI, and %AQ word memory. Discrete memory (%I, %Q, %M, etc.) sizes are not configurable. Word memory can be configured from 128 to 32,640 words in 128 word increments, which gives 255 possible sizes. The amount of memory available for a user program depends on how much is configured for word memory.

### Note

Configurable Memory has limited support in Logicmaster Version 9.02 and later (limited to 16K %R words, 8K %AI words, and 8K %AQ words), and full support in Control (Version 2.2 and later) and VersaPro (all versions).

## Additional Serial Ports (CPU351, CPU352, CPU363)

Although all Series 90-30 CPUs have a serial port that is accessed through the connector on the power supply, the CPU351, CPU352, and CPU363 each have two additional serial ports. The connectors for these additional serial ports are mounted on the front of each CPU. These two built-in serial ports eliminate the need for the CPU to access serial ports across the PLC backplane, resulting in better system performance. These two ports support the SNP/SNP-X master and slave protocols (see previous section “Break-Free SNP Protocol”), RTU slave protocol (in Firmware Version 8.0 and later), and the Serial I/O feature (in Firmware Version 8.0 and later) that lets you create a custom serial output. Instructions on how to use these ports can be found in the *Series 90 PLC Serial Communications User’s Manual*, GFK-0582C or later.

## Floating-Point Math

All Series 90-30 CPUs can work with integer numbers. (The set of integer numbers consists of all positive and negative whole numbers, including zero.) The floating-point math feature enables a CPU to work with decimal numbers in addition to integer numbers. It also provides trigonometric, logarithmic, exponential, and radian conversion functions. Floating-point math is also referred to as “real number” math. The CPU352 has always had hardware-based floating-point math capabilities due to its built-in math co-processor chip. Starting with CPU firmware release 9.0, all of the other CPUs in the 350 - 364 CPU group were provided with firmware-based floating-point math capability. Although there is a speed difference between the hardware-based floating-point math of the CPU352 and the firmware-based type, this will not be significant to many users. For applications where faster performance is important, the CPU352 is the best choice. The floating-point math instructions are explained in the *Series 90-30 PLC CPU Instruction Set Reference Manual*, GFK-0467K (the letter K is the revision or version indicator) or later.

## Flash Memory

All of the 350 - 364 CPUs have built-in Flash memory, which serves two purposes:

- It provides non-volatile storage of the CPU firmware.
- It gives you the option of storing program, configuration, and register data in non-volatile Flash memory. Two ways of using this memory are: (1) to store an on-board backup copy of user memory (although we still recommend that you keep a separate backup copy of your complete program folder), and (2) for running in a battery-less scheme. For details, please see Chapter 6.

## Keyswitch

All 350 - 364 CPUs have a keyswitch; however, some versions of the CPU firmware do not support all of the keyswitch features (see the section “Determining CPU Revision Levels” earlier in this chapter). These differences are described in this section. Note that the keyswitches on some of these CPUs are labeled ON/RUN and OFF/STOP and on others are just labeled ON and OFF. Regardless of the labeling, all of these keyswitches work as described below:

- **Flash Memory Protection:** This standard, hard-wired feature can be used to prevent Flash memory from being changed by unauthorized people (people without a key). When the key switch is in the ON position, Flash memory cannot be changed

(written to). This keyswitch feature will always be in effect, regardless of how the next two configurable features are set.

- **Run/Stop (configurable):** This feature was introduced in CPU firmware release 7.0. It is, by default, disabled. It is not functional unless the *R/S Switch:* parameter on the CPU configuration screen is set to *Enabled*. This feature, when enabled, lets you stop the PLC by turning the key switch to OFF, or start the PLC running by turning the key switch to ON (if there are no faults).

**If the PLC has a non-fatal fault,** turning the key switch from OFF to ON will cause the RUN light on the power supply to flash for 5 seconds. If you again turn the key switch OFF, then ON during the 5 seconds, the fault will clear and the PLC will go into run mode (and the RUN light will stay ON).

**If the PLC has a fatal fault,** you will not be able to use the keyswitch to either clear the fault or put the PLC into run mode. You will have to correct the cause of the fault before being able to resume operation.

- **RAM Memory and Override Protection (configurable):** This feature was introduced in CPU firmware release 8.0. This feature is, by default, disabled. It is not functional unless the *Mem Protect:* parameter on the CPU configuration screen is set to *Enabled*. If this feature is enabled and the keyswitch is ON, (1) user RAM memory cannot be changed (2) discrete points cannot be overridden, and (3) the TOD clock cannot be changed with the Hand Held Programmer (however, the TOD clock can still be changed using programming software).

**Protect your keys.** Each new 350 - 364 CPU is supplied with a pair of keys for the key switch. If you use one or more of the key switch protection features described above, we recommend you carefully guard your keys. If they are lost, misplaced, or stolen, you may be locked out from working on your PLC, and unauthorized persons may have access to it. Replacement keys can be purchased under part number 44A736756-G01. This kit contains 3 sets of CPU keys. All 350 - 364 CPUs use the same key.

Of course, you can choose to not use any of the keyswitch protection features, in which case you can leave the keyswitch set to the OFF position, and leave the two configurable keyswitch features set at their default (disabled) settings. Then, you will not need to use a key to access the PLC.

## Sequential Event Recorder (SER) Instruction

This functional instruction (programmed in ladder logic) was introduced in CPU firmware release 9.0 and is available in all of the 350 - 354 CPUs that have this firmware. The purpose of the SER is to provide a dynamic troubleshooting and debugging tool. In effect, it takes "snapshots" of the on/off status of groups of discrete points that you specify. You also specify how many of these snapshots to take, when and how often they will be taken, and where in memory they will be stored. The stored snapshots can be analyzed to see the time relationship of the bits sampled. Please see the *Series 90-30 PLC CPU Instruction Set Reference Manual*, GFK-0467K or later for details on using this instruction. Some feature highlights:

- An SER function block collects up to 32 contiguous or non-contiguous bits per sample.
- Each SER function block can capture up to 1024 samples.
- If the SER is embedded in a periodic subroutine, sampling rate is determined by the periodic subroutine execution rate.

- Only the trigger sample is time stamped. The trigger sample can be time-stamped in BCD (maximum resolution of 1 s) or POSIX format (maximum resolution of 10ms). The time stamp is only placed once at the trigger point. The SER does not support more than one time stamp per recording.
- The SER can be configured for pre-, mid-, or post-trigger modes.

## Embedded Ethernet Interface (CPU364)

The CPU364 consists of a CPU and an Ethernet Interface combined in one module. This module offers Ethernet capabilities formerly available only with the separate IC693CMM321 Ethernet module. The CPU364 offers several advantages compared to using a separate CPU and Ethernet module:

- It only occupies one slot in the PLC baseplate compared to the two slots required by separate CPU and Ethernet modules.
- The IC693CMM321 Ethernet module requires an external transceiver. The CPU364 does not require one since it has this functionality built-in. To use this internal transceiver, connect to the 10BASE-T port. However, if you choose, you may use an external transceiver by connecting to the CPU364's AAUI port, which bypasses the internal transceiver (see Appendix L for GE Fanuc transceiver information).
- Because they both reside in the CPU364 module, the CPU and Ethernet Interface can communicate without using the PLC backplane. This give faster communications speed compared to using separate CPU and Ethernet modules, which have to use the slower path across the PLC backplane.
- Beginning with Firmware Release 9.1, the Ethernet Global Data (EGD) and configurable Name Resolution features were added to the CPU364. These features are not supported by the IC693CMM321 Ethernet module. Logicmaster will not include support for these features. They will only be supported in Control, Version 2.2 or later, and in all versions of VersaPro programming software. For details about these features, please see publication GFK-1541A or later versions (when available), *TCP/IP Ethernet Communications for the Series 90 PLC User's Manual*.

## Hardware Features of the 350 - 364 CPUs

### CPU350 and CPU360 Hardware Features

These two modules look identical except for labeling.

- These modules feature an LED light, labeled "PS Port" that indicates serial port activity through the serial connector on the PLC power supply. Typically, this LED will flash while data is being transferred through the port, and will stay off when the port is inactive.
- These modules also have the keyswitch, described earlier in this chapter, that is standard on the 350 - 364 CPUs.

### CPU Firmware Upgrade

The CPU firmware, which is stored in Flash memory, is loaded through the serial port connector on the PLC Power Supply.

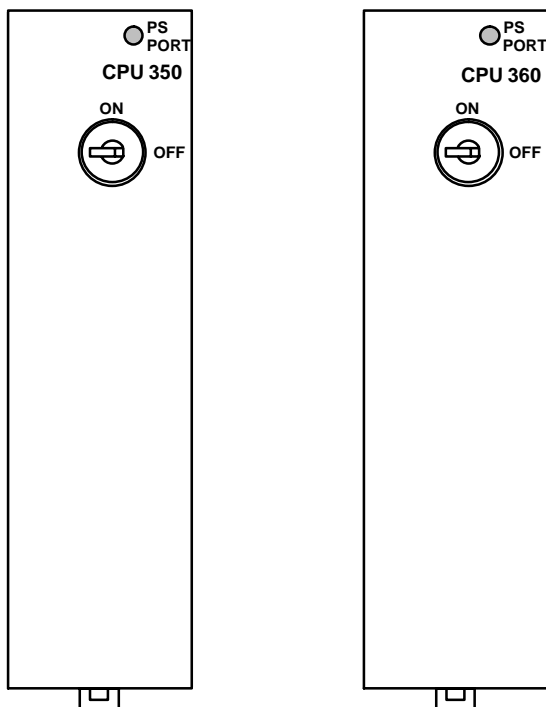

## CPU351, CPU352, and CPU363 Hardware Features

These three modules are similar in features and functionality. The CPU351 and CPU352 look identical except for labeling. The CPU363 has the same features as the other two, but the orientation of its Port 1 and Port 2 connectors is reversed from those of the CPU351 and CPU352, and its LED indicator lights, key switch, and shield ground connector are in different locations. (The shield ground connector is on the front panel of the CPU363, labeled "FRAME," but is located on the bottom of the CPU351 and CPU352 modules.)

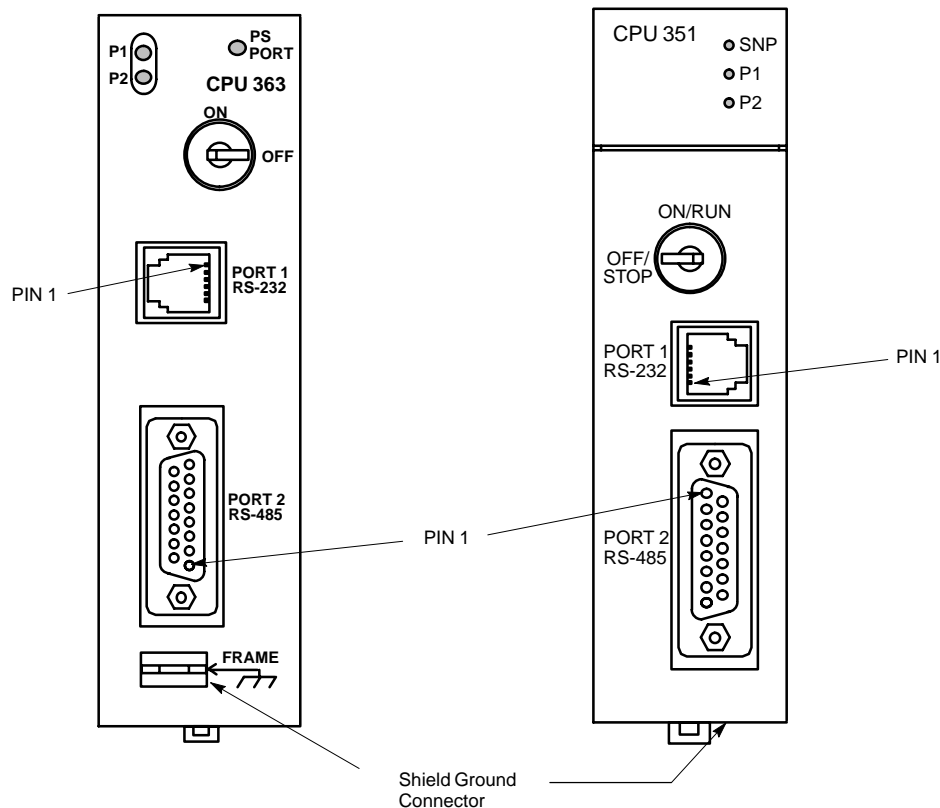

Figure 5-4. CPUs 351, 352, and 363

### CPU Firmware Upgrade

The CPU firmware, which is stored in Flash memory, is loaded through the Port 1 connector on these modules' faceplate using Loader software supplied with the firmware upgrade kit. The IC693CBL316 cable can be used for this purpose (see Chapter 10 for data sheet on this cable).

### Keyswitch

This is a standard CPU keyswitch, discussed earlier in this chapter.

### Shield Ground Connection Tab

This tab is located on the bottom of the CPU351 and 352 modules and on the front of the CPU363 module. It is used to make the module's shield ground connection. A wire with

the applicable terminal ends is supplied with the module for this purpose. Please see the section "Module Shield Grounding" in Chapter 2 ("Installation") for details.

## Serial Ports

The 351, 352, and 363 CPUs have three serial ports. One is accessed through a connector on the PLC power supply (standard serial port found on all Series 90-30 CPUs), and the connectors for the other two are on the modules' front panel, labeled Port 1 and Port 2.

The CPU351, 352, and 363 serial ports are configurable using the programming software configurator function. Each port can also be configured using a COMM\_REQ. For details about using these ports and about the COMM\_REQ instruction, please see publication GFK-0582, *Series 90 PLC Serial Communications User's Manual*.

### Serial Port Front Panel Connectors

- **Port 1**, the top port is RS-232 compatible. This port has a 6-pin RJ-11 connector. This connector has female contacts and is similar to modular jacks commonly used for telephones and modems. The IC693CBL316 can be used to access this port, providing a direct connection to an RS-232 device without the need for a converter. See Chapter 10 for a data sheet on this cable.
- **Port 2**, the bottom port is RS-485 compatible. Access to Port 2 is through a 15-pin D connector that has female contacts.

### Serial Port Status LEDs

The CPU351 and CPU352 have three LEDs that indicate the status of serial port activity on the CPU.

- The **SNP** LED on the CPU351 and CPU352 is called **PS Port** on the CPU363. This refers to the port that uses the serial connector on the PLC's power supply. This LED flashes when data is being transferred through the port. It remains off when the port is inactive.
- The **P1** LED will flash when data is being transferred through Port 1, the RS-232 port. It remains off when the port is inactive.
- The **P2** LED will flash when data is being transferred through Port 2, the RS-485 port. It remains off when the port is inactive.

### Protocols Supported

Starting with Firmware Release 9.00, Break-Free SNP became the default protocol on the three Serial Ports on these modules. See previous section "Break-Free SNP Protocol" for details.

#### SNP Port (Through Power Supply Connector)

- SNP slave.
- SNP-X slave

#### Port 1 and Port 2 (Through Module's Front Panel Connectors)

- SNP master and slave
- SNP-X master and slave
- RTU slave (starting with Firmware Release 8.0)
- Serial I/O – Limited functionality (write only) starting with Firmware Release 8.0, will have full functionality (read and write) starting with Firmware Release 10.0.

Used with autodialer feature to call a pager. To use this feature, configure protocol as *Custom*. See GFK-0582, *Series 90 PLC Serial Communications User's Manual* for details.

### Pin Assignments for CPU351, CPU352, and CPU363 Serial Ports 1 & 2

The following two tables describe the pin assignments for each of the two front panel serial ports on the CPU351, CPU352, and CPU363.

**Table 5-5. Port 1 (RS-232)**

| Pin Number | Signal Name | Description     |
|------------|-------------|-----------------|
| 1          | CTS         | Clear To Send   |
| 2          | TXD         | Transmit Data   |
| 3          | 0V          | Signal Ground   |
| 4          | 0V          | Signal Ground   |
| 5          | RXD         | Receive Data    |
| 6          | RTS         | Request to Send |

**Table 5-6. Port 2 (RS-485)**

| Pin Number | Signal Name | Description                  |
|------------|-------------|------------------------------|
| 1          | Shield      | Cable Shield                 |
| 2          | NC          | No Connection                |
| 3          | NC          | No Connection                |
| 4          | NC          | No Connection                |
| 5          | +5VDC       | Logic Power *                |
| 6          | RTS(A)      | Differential Request to Send |
| 7          | SG          | Signal Ground                |
| 8          | CTS(B')     | Differential Clear To Send   |
| 9          | RT          | Resistor Termination         |
| 10         | RD(A)       | Differential Receive Data    |
| 11         | RD(B')      | Differential Receive Data    |
| 12         | SD(A)       | Differential Send Data       |
| 13         | SD(B)       | Differential Send Data       |
| 14         | RTS(B')     | Differential Request To Send |
| 15         | CTS(A)      | Differential Clear To Send   |

\* Note that Pin 5 provides Isolated +5 VDC power (100 mA maximum) for powering external options.

## CPU364 Hardware Features

This module has four LED indicator lights, an Ethernet Restart pushbutton, a standard CPU keyswitch, three port connectors, and a shield ground connection tab (labeled “FRAME”).

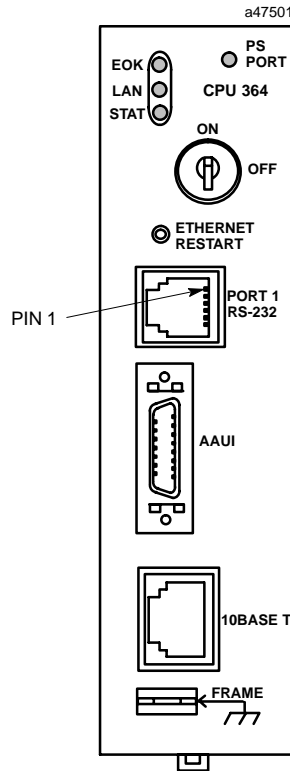

### LED Indicators

There are four LED Indicators. Three relate to the Ethernet interface: EOK, LAN, and STAT. These can be ON, OFF, FLASHING slow, or FLASHING fast in several different combinations. The full functionality of these LEDs is detailed in GFK-1541, *TCP/IP Ethernet Communications for the Series 90 PLC User’s Manual*.

The fourth LED, PS PORT, is for the CPU’s serial port and is not related to the Ethernet interface. This LED will flash while data is being transferred through the SNP serial port connector on the PLC power supply, and will stay off when the port is inactive. (On some early production 364 CPUs, this LED is labeled “SNP.”) All Series 90-30 CPUs have this standard serial port.

### Ethernet Restart Pushbutton

This pushbutton performs four functions: LED test, Restart, Restart and enter Software Load state, and Restart and enter Maintenance state. These are detailed in GFK-1541, *TCP/IP Ethernet Communications for the Series 90 PLC User’s Manual*.

### Keyswitch

This is a standard CPU keyswitch, discussed earlier in this chapter.

## Front Panel Connectors

The full functionality of these ports is detailed in GFK-1541, *TCP/IP Ethernet Communications for the Series 90 PLC User's Manual*.

- **Port 1, RS-232** - This connector is used for two purposes: (1) To connect a terminal or terminal emulator to access the Station Manager software on the Ethernet Interface. (2) To connect to a Personal Computer that will be used to update the Ethernet Interface firmware (the CPU firmware is updated separately through the connector on the power supply). This RJ-11 connector has the same pinout as Port 1 of the CPUs 351, 352, and 353, shown in Table 5-5. The IC693CBL316 cable can be used to access this port. See Chapter 10 for a data sheet on this cable.
- **AAUI port** - This 14-pin AAUI port connects via a user-supplied IEEE 802.3 transceiver cable to an external Ethernet-compatible transceiver such as the GE Fanuc catalog number IC649AEA102 (for 10Base T) or IC649AEA103 (for 10Base 2). See Appendix L for details on these transceivers.
- **10Base T port** - This 8-pin, RJ-45 port provides a direct connection to a 10Base T (twisted pair) Ethernet network without the need for an external transceiver.

## Shield Ground Connection Tab

This tab is used to make the module's shield ground connection. A wire with the applicable terminal ends is supplied with the module for this purpose. Please see the section "CPU363 and 364 Shield Grounding" in Chapter 2 ("Installation") for details.

## Firmware Upgrade

- The CPU firmware, which is stored in Flash memory, is loaded through the serial port connector on the PLC Power Supply using a personal computer that has been equipped with the loader and CPU firmware software.
- The Ethernet Interface firmware, stored in Flash memory, is loaded through the module's front panel Port 1 connector using a personal computer that has been equipped with the loader and Ethernet firmware software. Cable IC693CBL316 is required (see Chapter 10 for details on this cable).

## CPU Data Sheets

This section provides data sheets describing each of the Series 90-30 CPU modules. For information on the State Logic CPUs, see Chapter 9, "State Logic Products."

### ***CPU Model List***

- IC693CPU311 5-slot baseplate with embedded CPU, 1K Byte Register Memory
- IC693CPU313 5-slot baseplate with embedded CPU, 2K Bytes Register Memory
- IC693CPU323 10-slot baseplate with embedded CPU
- IC693CPU331 CPU module, 10 MHz
- IC693CPU340 CPU module, 20 MHz, 32K Bytes User Program Memory
- IC693CPU341 CPU module, 20 MHz, 80K Bytes User Program Memory
- IC693CPU350 CPU module, 25 MHz
- IC693CPU351 CPU module, 25 MHz, with two extra serial ports
- IC693CPU352 CPU module, 25 MHz, math coprocessor, two extra serial ports
- IC693CPU360 CPU module, 25 MHz
- IC693CPU363 CPU module, 25 Mhz, with two extra serial ports
- IC693CPU364 CPU module, 25 Mhz, with Ethernet interface

# CPU311

Catalog Number IC693CPU311

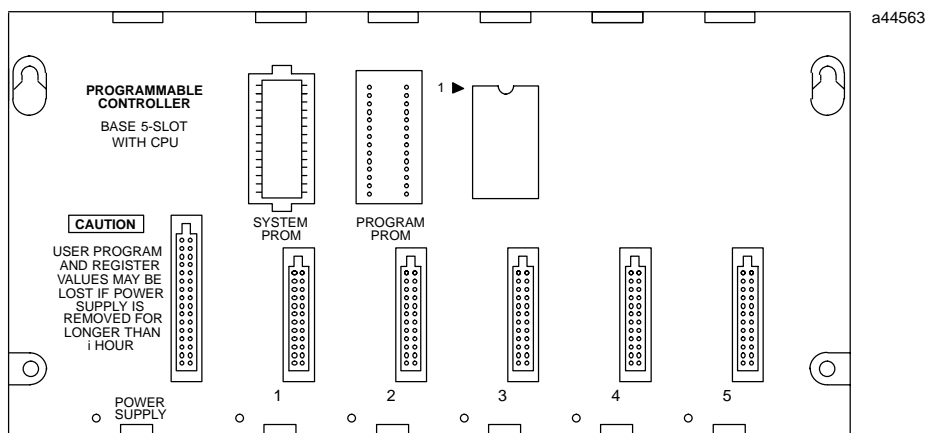

|  |  |
|--|--|
| <b>CPU Type</b>  | 5-slot baseplate with embedded CPU   |
| <b>Total Baseplates per System</b>   | 1  |
| <b>Load Required from PowerSupply</b>  | 410 milliamps from +5 VDC supply   |
| <b>ProcessorSpeed</b>  | 10MegaHertz  |
| <b>Processor Type</b>  | 80188  |
| <b>Operating Temperatue</b>  | 0 to 60 degrees C (32 to 140 degrees F) ambient  |
| <b>Typical Scan Rate</b>   | 18 milliseconds per 1K of logic (boolean contacts)   |
| <b>User ProgramMemory(maximum)</b>   | 6K Bytes   |
| <b>Discrete Input Points - %I</b>  | 160 (maximum - combined inputs + outputs)  |
| <b>Discrete Output Points - %Q</b>   | 160 (maximum - combined outputs + inputs)  |
| <b>Discrete GlobalMemory - %G</b>  | 1280 bits  |
| <b>Internal Coils - %M</b>   | 1024 bits  |
| <b>Output (Temporary) Coils - %T</b>   | 256 bits   |
| <b>System Status References - %S</b>   | 128 bits (%S, %SA, %SB, %SC - 32 bits each)  |
| <b>RegisterMemory - %R</b>   | 512 words  |
| <b>Analog Inputs - %AI</b>   | 64 words   |
| <b>Analog Outputs - %AQ</b>  | 32 words   |
| <b>System Registers</b> (for reference table viewing only; cannot be referenced in user logic program) | 16 words (%SR)   |
| <b>Timers/Counters</b>   | 170  |
| <b>Shift Registers</b>   | yes  |
| <b>Built-in Serial Ports</b>   | 1 (uses connector on PLC power supply). Supports SNP slave and SNP-X slave protocols.          |
| <b>Communications</b>  | LAN- Supports multidrop. Also supports Ethernet, FIP, Profibus, GBC, GCM, GCM+ option modules. |
| <b>Override</b>  | no   |
| <b>Battery Backed Clock</b>  | no   |
| <b>Interrupts</b>  | no   |
| <b>Type of Memory Storage</b>  | RAM and optional EPROM or EEPROM   |
| <b>PCM/CCM Compatibility</b>   | no   |

# CPU313

Catalog Number IC693CPU313

a44563

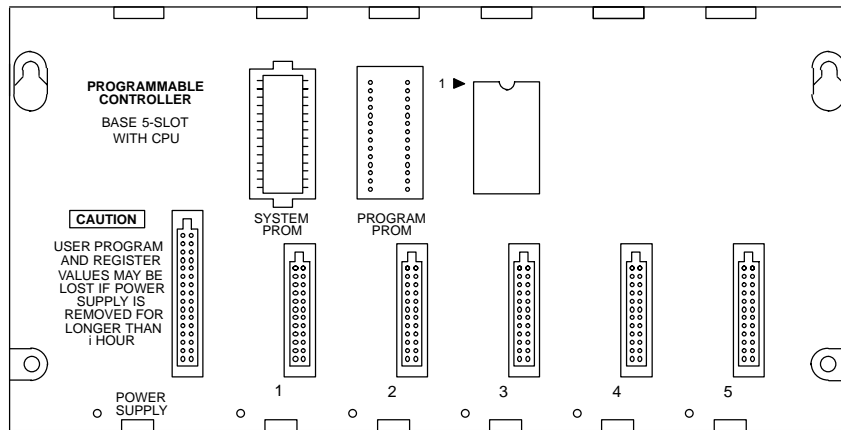

|  |  |
|--|--|
| <b>CPU Type</b>  | 5-slot baseplate with embedded CPU   |
| <b>Total Baseplates per System</b>   | 1  |
| <b>Load Required from PowerSupply</b>  | 430 milliamps from +5 VDC supply   |
| <b>ProcessorSpeed</b>  | 10MegaHertz  |
| <b>Processor Type</b>  | 80188  |
| <b>Operating Temperatue</b>  | 0 to 60 degrees C (32 to 140 degrees F) ambient  |
| <b>Typical Scan Rate</b>   | 0.6 milliseconds per 1K of logic (boolean contacts)  |
| <b>User ProgramMemory (maximum)</b>  | 12K Bytes (6K bytes prior to release 7)  |
| <b>Discrete Input Points - %I</b>  | 160 (maximum - combined inputs + outputs)  |
| <b>Discrete Output Points - %Q</b>   | 160 (maximum - combined outputs + inputs)  |
| <b>Discrete Global Memory - %G</b>   | 1280 bits  |
| <b>Internal Coils - %M</b>   | 1024 bits  |
| <b>Output (Temporary) Coils - %T</b>   | 256 bits   |
| <b>System Status References - %S</b>   | 128 bits (%S, %SA, %SB, %SC - 32 bits each)  |
| <b>Register Memory - %R</b>  | 1024 words   |
| <b>Analog Inputs - %AI</b>   | 64 words   |
| <b>Analog Outputs - %AQ</b>  | 32 words   |
| <b>System Registers</b> (for reference table viewing only; cannot be referenced in user logic program) | 16 words (%SR)   |
| <b>Timers/Counters</b>   | 170  |
| <b>Shift Registers</b>   | yes  |
| <b>Built-in Ports</b>  | 1 (uses connector on PLC power supply). Supports SNP slave and SNP-X slave protocols.          |
| <b>Communications</b>  | LAN- Supports multidrop. Also supports Ethernet, FIP, Profibus, GBC, GCM, GCM+ option modules. |
| <b>Override</b>  | no   |
| <b>Battery Backed Clock</b>  | no   |
| <b>Interrupts</b>  | no   |
| <b>Type of Memory Storage</b>  | RAM and optional EPROM or EEPROM   |
| <b>PCM/CCM Compatibility</b>   | no   |

# CPU323

Catalog Number IC693CPU323

a45134

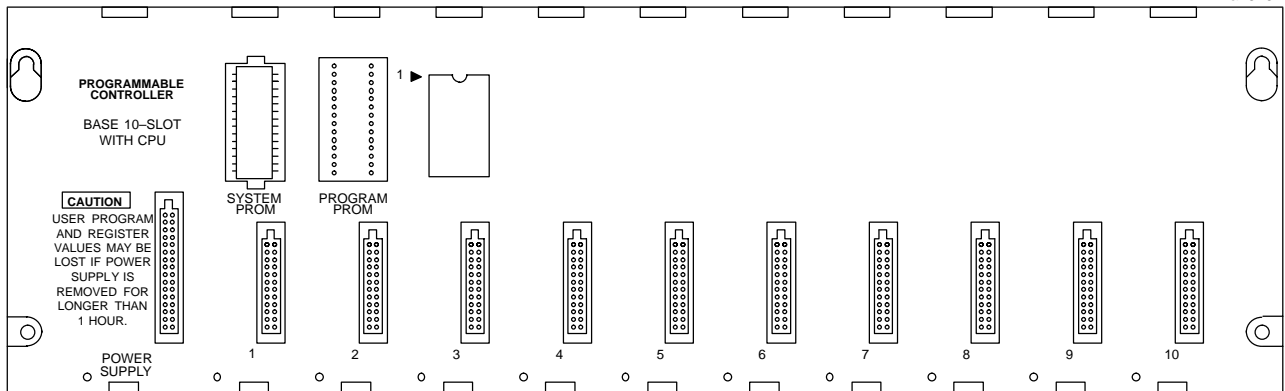

|  |  |
|--|--|
| <b>CPU Type</b>  | 10-slot baseplate with embedded CPU  |
| <b>Total Baseplates per System</b>   | 1  |
| <b>Load Required from Power Supply</b>   | 430 milliamps from +5 VDC supply   |
| <b>Processor Speed</b>   | 10 MegaHertz   |
| <b>Processor Type</b>  | 80188  |
| <b>Operating Temperature</b>   | 0 to 60 degrees C (32 to 140 degrees F) ambient  |
| <b>Typical Scan Rate</b>   | 0.6 milliseconds per 1K of logic (boolean contacts)  |
| <b>User Program Memory (maximum)</b>   | 12K Bytes (6K bytes prior to release 7)  |
| <b>Discrete Input Points - %I</b>  | 320 (maximum - combined inputs + outputs)  |
| <b>Discrete Output Points - %Q</b>   | 320 (maximum - combined outputs + inputs)  |
| <b>Discrete Global Memory - %G</b>   | 1280 bits  |
| <b>Internal Coils - %M</b>   | 1024 bits  |
| <b>Output (Temporary) Coils - %T</b>   | 256 bits   |
| <b>System Status References - %S</b>   | 128 bits (%S, %SA, %SB, %SC - 32 bits each)  |
| <b>Register Memory - %R</b>  | 1024 words   |
| <b>Analog Inputs - %AI</b>   | 64 words   |
| <b>Analog Outputs - %AQ</b>  | 32 words   |
| <b>System Registers</b> (for reference table viewing only; cannot be referenced in user logic program) | 16 words (%SR)   |
| <b>Timers/Counters</b>   | 340  |
| <b>Shift Registers</b>   | yes  |
| <b>Built-in Ports</b>  | 1 (uses connector on PLC power supply). Supports SNP slave and SNP-X slave protocols.          |
| <b>Communications</b>  | LAN- Supports multidrop. Also supports Ethernet, FIP, Profibus, GBC, GCM, GCM+ option modules. |
| <b>Override</b>  | no   |
| <b>Battery Backed Clock</b>  | no   |
| <b>Interrupts</b>  | no   |
| <b>Type of Memory Storage</b>  | RAM and optional EPROM or EEPROM   |
| <b>PCM/CCM Compatibility</b>   | no   |

# CPU331

Catalog Number IC693CPU331

|  |  |
|--|--|
| <b>CPU Type</b>  | Single slot CPU module   |
| <b>Total Baseplates per System</b>   | 5 (1 CPU baseplate + 4 expansion and/or remote)  |
| <b>Load Required from Power Supply</b>   | 350 milliamps from +5 VDC supply   |
| <b>Processor Speed</b>   | 10 MegaHertz   |
| <b>Processor Type</b>  | 80188  |
| <b>Operating Temperature</b>   | 0 to 60 degrees C (32 to 140 degrees F) ambient  |
| <b>Typical Scan Rate</b>   | 0.4 milliseconds per 1K of logic (boolean contacts)  |
| <b>User Program Memory (maximum)</b>   | 16K Bytes  |
| <b>Discrete Input Points - %I</b>  | 512  |
| <b>Discrete Output Points - %Q</b>   | 512  |
| <b>Discrete Global Memory - %G</b>   | 1280 bits  |
| <b>Internal Coils - %M</b>   | 1024 bits  |
| <b>Output (Temporary) Coils - %T</b>   | 256 bits   |
| <b>System Status References - %S</b>   | 128 bits (%S, %SA, %SB, %SC - 32 bits each)  |
| <b>Register Memory - %R</b>  | 2048 words   |
| <b>Analog Inputs - %AI</b>   | 128 words  |
| <b>Analog Outputs - %AQ</b>  | 64 words   |
| <b>System Registers</b> (for reference table viewing only; cannot be referenced in user logic program) | 16 words (%SR)   |
| <b>Timers/Counters</b>   | 680  |
| <b>Shift Registers</b>   | yes  |
| <b>Built-in Ports</b>  | 1 (uses connector on PLC power supply). Supports SNP/SNPX slave protocols. Requires CMM module for SNP/SNP-X master, CCM, or RTU slave support; PCM module for RTU master support. |
| <b>Communications</b>  | LAN- Supports multidrop. Also supports Ethernet, FIP, Profibus, GBC, GCM, GCM+ option modules.   |
| <b>Override</b>  | yes  |
| <b>Battery Backed Clock</b>  | yes  |
| <b>Interrupts</b>  | no   |
| <b>Type of Memory Storage</b>  | RAM and optional EPROM or EEPROM   |
| <b>PCM/CCM Compatibility</b>   | yes  |

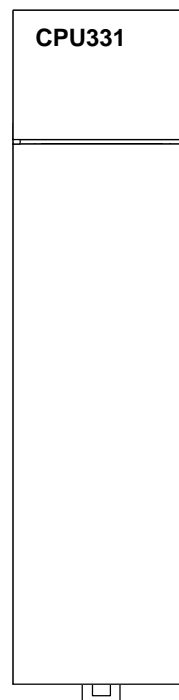

# CPU340

Catalog Number IC693CPU340

|  |  |
|--|--|
| <b>CPU Type</b>  | Single slot CPU module   |
| <b>Total Baseplates per System</b>   | 5 (1 CPU baseplate + 4 expansion and/or remote)  |
| <b>Load Required from Power Supply</b>   | 490 milliamps from +5 VDC supply   |
| <b>Processor Speed</b>   | 20 MegaHertz   |
| <b>Processor Type</b>  | 80C188XL   |
| <b>Operating Temperature</b>   | 0 to 60 degrees C (32 to 140 degrees F) ambient  |
| <b>Typical Scan Rate</b>   | 0.3 milliseconds per 1K of logic (boolean contacts)  |
| <b>User Program Memory (maximum)</b>   | 32K Bytes  |
| <b>Discrete Input Points - %I</b>  | 512  |
| <b>Discrete Output Points - %Q</b>   | 512  |
| <b>Discrete Global Memory - %G</b>   | 1280 bits  |
| <b>Internal Coils - %M</b>   | 1024 bits  |
| <b>Output (Temporary) Coils - %T</b>   | 256 bits   |
| <b>System Status References - %S</b>   | 128 bits (%S, %SA, %SB, %SC - 32 bits each)  |
| <b>Register Memory - %R</b>  | 9999 words   |
| <b>Analog Inputs - %AI</b>   | 1024 words   |
| <b>Analog Outputs - %AQ</b>  | 256 words  |
| <b>System Registers</b> (for reference table viewing only; cannot be referenced in user logic program) | 16 words (%SR)   |
| <b>Timers/Counters</b>   | >2000  |
| <b>Shift Registers</b>   | yes  |
| <b>Built-in Ports</b>  | 1 (uses connector on PLC power supply). Supports SNP/SNPX slave protocols. Requires CMM module for SNP/SNP-X master, CCM, or RTU slave support; PCM module for RTU master support. |
| <b>Communications</b>  | LAN- Supports multidrop. Also supports Ethernet, FIP, Profibus, GBC, GCM, GCM+ option modules.   |
| <b>Override</b>  | yes  |
| <b>Battery Backed Clock</b>  | yes  |
| <b>Interrupts</b>  | yes  |
| <b>Type of Memory Storage</b>  | RAM and optional Flash   |
| <b>PCM/CCM Compatibility</b>   | yes  |

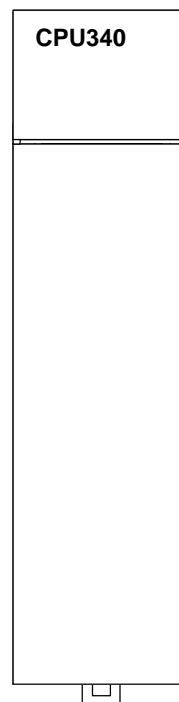

# CPU341

Catalog Number IC693CPU341

|  |  |
|--|--|
| <b>CPU Type</b>  | Single slot CPU module   |
| <b>Total Baseplates per System</b>   | 5 (1 CPU baseplate + 4 expansion and/or remote)  |
| <b>Load Required from Power Supply</b>   | 490 milliamps from +5 VDC supply   |
| <b>Processor Speed</b>   | 20 MegaHertz   |
| <b>Processor Type</b>  | 80C188XL   |
| <b>Operating Temperature</b>   | 0 to 60 degrees C (32 to 140 degrees F) ambient  |
| <b>Typical Scan Rate</b>   | 0.3 milliseconds per 1K of logic (boolean contacts)  |
| <b>User Program Memory (maximum)</b>   | 80K Bytes  |
| <b>Discrete Input Points - %I</b>  | 512  |
| <b>Discrete Output Points - %Q</b>   | 512  |
| <b>Discrete Global Memory - %G</b>   | 1280 bits  |
| <b>Internal Coils - %M</b>   | 1024 bits  |
| <b>Output (Temporary) Coils - %T</b>   | 256 bits   |
| <b>System Status References - %S</b>   | 128 bits (%S, %SA, %SB, %SC - 32 bits each)  |
| <b>Register Memory - %R</b>  | 9999 words   |
| <b>Analog Inputs - %AI</b>   | 1024 words   |
| <b>Analog Outputs - %AQ</b>  | 256 words  |
| <b>System Registers</b> (for reference table viewing only; cannot be referenced in user logic program) | 16 words (%SR)   |
| <b>Timers/Counters</b>   | >2000  |
| <b>Shift Registers</b>   | yes  |
| <b>Built-in Ports</b>  | 1 (uses connector on PLC power supply). Supports SNP/SNPX slave protocols. Requires CMM module for SNP/SNP-X master, CCM, or RTU slave support; PCM module for RTU master support. |
| <b>Communications</b>  | LAN- Supports multidrop. Also supports Ethernet, FIP, Profibus, GBC, GCM, GCM+ option modules.   |
| <b>Override</b>  | yes  |
| <b>Battery Backed Clock</b>  | yes  |
| <b>Interrupts</b>  | yes  |
| <b>Type of Memory Storage</b>  | RAM and optional EPROM or EEPROM for early versions. Starting with hardware version IC693CPU341J and firmware Release 4.61, only RAM and optional Flash are supported.             |
| <b>PCM/CCM Compatibility</b>   | yes  |

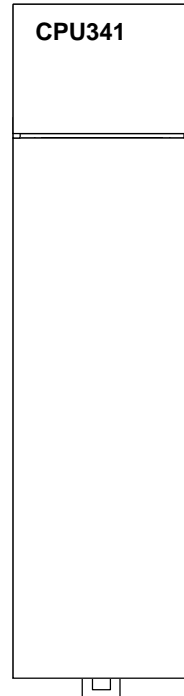

# CPU350

Catalog Number IC693CPU350

|  |   |
|--|---|
| <b>CPU Type</b>  | Single slot CPU module  |
| <b>Total Baseplates per System</b>   | 8 (CPU baseplate + 7 expansion and/or remote)   |
| <b>Load Required from Power Supply</b>   | 670 milliamps from +5 VDC supply  |
| <b>Processor Speed</b>   | 25 MegaHertz  |
| <b>Processor Type</b>  | 80386EX   |
| <b>Operating Temperature</b>   | 0 to 60 degrees C (32 to 140 degrees F) ambient   |
| <b>Typical Scan Rate</b>   | .22 milliseconds per 1K of logic (boolean contacts)   |
| <b>User Program Memory (maximum)</b>   | 32K Bytes (not configurable)  |
| <b>Discrete Input Points - %I</b>  | 2,048   |
| <b>Discrete Output Points - %Q</b>   | 2,048   |
| <b>Discrete Global Memory - %G</b>   | 1,280 bits  |
| <b>Internal Coils - %M</b>   | 4,096 bits  |
| <b>Output (Temporary) Coils - %T</b>   | 256 bits  |
| <b>System Status References - %S</b>   | 128 bits (%S, %SA, %SB, %SC - 32 bits each)   |
| <b>Register Memory - %R</b>  | 9,999 words   |
| <b>Analog Inputs - %AI</b>   | 2,048 words   |
| <b>Analog Outputs - %AQ</b>  | 512 words   |
| <b>System Registers</b> (for reference table viewing only; cannot be referenced in user logic program) | 28 words (%SR)  |
| <b>Timers/Counters</b>   | >2,000  |
| <b>Shift Registers</b>   | Yes   |
| <b>Built-in Serial Port</b>  | 1 (uses connector on PLC power supply). Supports SNP/SNPX slave protocols. Requires CMM module for SNP/SNP-X master, CCM, or RTU slave protocol support; PCM module for RTU master support. |
| <b>Communications</b>  | LAN- Supports multidrop. Also supports Ethernet, FIP, Profibus, GBC, GCM, GCM+ option modules.  |
| <b>Override</b>  | Yes   |
| <b>Battery Backed Clock</b>  | Yes   |
| <b>Interrupts</b>  | Supports the periodic subroutine feature  |
| <b>Type of Memory Storage</b>  | RAM and Flash   |
| <b>PCM/CCM Compatibility</b>   | Yes   |
| <b>Floating Point Math Support</b>   | Yes. Firmware-based in firmware releases 9.0 and later  |

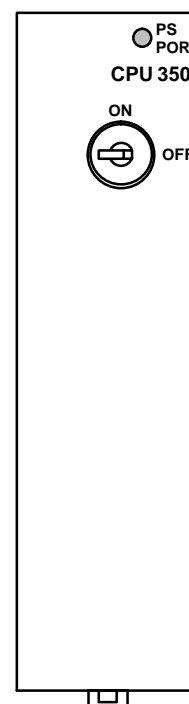

# CPU351

Catalog Number IC693CPU351

|   |   |
|---|---|
| <b>CPU Type</b>   | Single slot CPU module  |
| <b>Total Baseplates per System</b>  | 8 (CPU baseplate + 7 expansion and/or remote)   |
| <b>Load Required from Power Supply</b>  | 890 milliamps from +5 VDC supply  |
| <b>Processor Speed</b>  | 25 MegaHertz  |
| <b>Processor Type</b>   | 80386EX   |
| <b>Operating Temperature</b>  | 0 to 60 degrees C (32 to 140 degrees F) ambient   |
| <b>Typical Scan Rate</b>  | .22 milliseconds per 1K of logic (boolean contacts)   |
| <b>User Program Memory (maximum)</b>  | Starting with firmware Release 9.0, 240K Bytes. Note: Actual size of available user program memory depends on the amounts configured for the %R, %AI, and %AQ configurable word memory types (see below). For firmware prior to Release 9.0, fixed size is 80K bytes. |
| <b>Discrete Input Points - %I</b>   | 2,048   |
| <b>Discrete Output Points - %Q</b>  | 2,048   |
| <b>Discrete Global Memory - %G</b>  | 1,280 bits  |
| <b>Internal Coils - %M</b>  | 4,096 bits  |
| <b>Output (Temporary) Coils - %T</b>  | 256 bits  |
| <b>System Status References - %S</b>  | 128 bits (%S, %SA, %SB, %SC - 32 bits each)   |
| <b>Register Memory - %R</b>   | Starting with firmware Release 9.0, configurable in 128 word increments from 128 to 16,384 word with Logicmaster and from 128 to 32,640 words with Control version 2.2. For firmware prior to Release 9.0, fixed size is 9,999 words.                                 |
| <b>Analog Inputs - %AI</b>  | Starting with firmware Release 9.0, configurable in 128 word increments from 128 to 16,384 word with Logicmaster and from 128 to 32,640 words with Control version 2.2. For firmware prior to Release 9.0, fixed size is 9,999 words.                                 |
| <b>Analog Outputs - %AQ</b>   | Starting with firmware Release 9.0, configurable in 128 word increments from 128 to 16,384 word with Logicmaster and from 128 to 32,640 words with Control version 2.2. For firmware prior to Release 9.0, fixed size is 9,999 words.                                 |
| <b>System Registers (for reference table viewing only; cannot be referenced in logic program)</b> | 28 words (%SR)  |
| <b>Timers/Counters</b>  | >2,000  |
| <b>Shift Registers</b>  | Yes   |
| <b>Built-in Serial Ports</b>  | Three ports. Supports SNP/SNPX slave (on power supply connector) and RTU slave, SNP/SNPX master/slave, Serial I/O (on Ports 1 and 2). Requires CMM module for CCM; PCM module for RTU master support.   |
| <b>Communications</b>   | LAN- Supports multidrop. Also supports Ethernet, FIP, Profibus, GBC, GCM, GCM+ option modules.  |
| <b>Override</b>   | Yes   |
| <b>Battery Backed Clock</b>   | Yes   |
| <b>Interrupt Support</b>  | Supports the Periodic Subroutine feature.   |
| <b>Type of Memory Storage</b>   | RAM and Flash   |
| <b>PCM/CCM Compatibility</b>  | Yes   |
| <b>Floating Point Math Support</b>  | Yes, firmware-based in firmware Release 9.0 and later.  |

The CPU351 is supported by Logicmaster 90-30/20/ Micro programming and configuration software Release 6.00 and later releases, and Control programming and configuration software Release 2.0 and later releases.

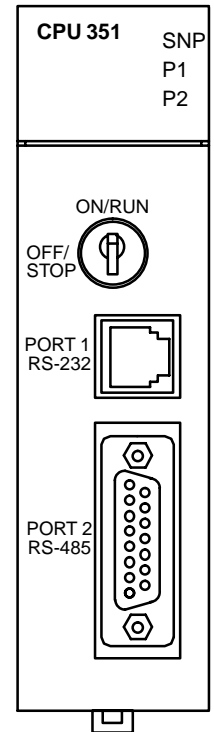

# CPU352

Catalog Number IC693CPU352

|   |   |
|---|---|
| <b>CPU Type</b>   | Single slot CPU module  |
| <b>Total Baseplates per System</b>  | 8 (CPU baseplate + 7 expansion and/or remote)   |
| <b>Load Required from Power Supply</b>  | 890 milliamps from +5 VDC supply  |
| <b>Processor Speed</b>  | 25 MegaHertz  |
| <b>Processor Type</b>   | 80386EX   |
| <b>Operating Temperature</b>  | 0 to 60 degrees C (32 to 140 degrees F) ambient   |
| <b>Typical Scan Rate</b>  | .22 milliseconds per 1K of logic (boolean contacts)   |
| <b>User Program Memory (maximum)</b>  | Starting with firmware Release 9.0, 240K Bytes. Note: Actual size of available user program memory depends on the amounts configured for the %R, %AI, and %AQ configurable word memory types (see below). For firmware prior to Release 9.0, fixed size is 80K bytes. |
| <b>Discrete Input Points - %I</b>   | 2,048   |
| <b>Discrete Output Points - %Q</b>  | 2,048   |
| <b>Discrete Global Memory - %G</b>  | 1,280 bits  |
| <b>Internal Coils - %M</b>  | 4,096 bits  |
| <b>Output (Temporary) Coils - %T</b>  | 256 bits  |
| <b>System Status References - %S</b>  | 128 bits (%S, %SA, %SB, %SC - 32 bits each)   |
| <b>Register Memory - %R</b>   | Starting with firmware Release 9.0, configurable in 128 word increments from 128 to 16,384 word with Logicmaster and from 128 to 32,640 words with Control version 2.2. For firmware prior to Release 9.0, fixed size is 9,999 words.                                 |
| <b>Analog Inputs - %AI</b>  | Starting with firmware Release 9.0, configurable in 128 word increments from 128 to 16,384 word with Logicmaster and from 128 to 32,640 words with Control version 2.2. For firmware prior to Release 9.0, fixed size is 9,999 words.                                 |
| <b>Analog Outputs - %AQ</b>   | Starting with firmware Release 9.0, configurable in 128 word increments from 128 to 16,384 word with Logicmaster and from 128 to 32,640 words with Control version 2.2. For firmware prior to Release 9.0, fixed size is 9,999 words.                                 |
| <b>System Registers (for reference table viewing only; cannot be referenced in logic program)</b> | 28 words (%SR)  |
| <b>Timers/Counters</b>  | >2,000  |
| <b>Shift Registers</b>  | Yes   |
| <b>Built-in Serial Ports</b>  | Three ports. Supports SNP/SNPX slave (on power supply connector) and RTU slave, SNP/SNPX master/slave, Serial I/O (on Ports 1 and 2). Requires CMM module for CCM; PCM module for RTU master support.   |
| <b>Communications</b>   | LAN- Supports multidrop. Also supports Ethernet, FIP, Profibus, GBC, GCM, GCM+ option modules.  |
| <b>Override</b>   | Yes   |
| <b>Battery Backed Clock</b>   | Yes   |
| <b>Interrupt Support</b>  | Supports the Periodic Subroutine feature.   |
| <b>Type of Memory Storage</b>   | RAM and Flash   |
| <b>PCM/CCM Compatibility</b>  | Yes   |
| <b>Floating Point Math Support</b>  | Yes, hardware-based (built-in math co-processor)  |

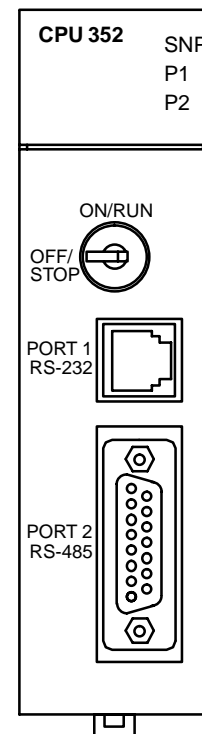

The CPU352 is supported by Logicmaster 90-30/20/ Micro programming and configuration software Release 7.00 and later releases, and Control programming and configuration software Release 2.0 and later releases.

# CPU360

Catalog Number IC693CPU360

|   |   |
|---|---|
| <b>CPU Type</b>   | Single slot CPU module  |
| <b>Total Baseplates per System</b>  | 8 (CPU baseplate + 7 expansion and/or remote)   |
| <b>Load Required from Power Supply</b>  | 670 milliamps from +5 VDC supply  |
| <b>Processor Speed</b>  | 25 MegaHertz  |
| <b>Processor Type</b>   | 80386EX   |
| <b>Operating Temperature</b>  | 0 to 60 degrees C (32 to 140 degrees F) ambient   |
| <b>Typical Scan Rate</b>  | .22 milliseconds per 1K of logic (boolean contacts)   |
| <b>User Program Memory (maximum)</b>  | Starting with firmware Release 9.0, 240K Bytes. Note: Actual size of available user program memory depends on the amounts configured for the %R, %AI, and %AQ configurable word memory types (see below). For firmware prior to Release 9.0, fixed size is 80K bytes. |
| <b>Discrete Input Points - %I</b>   | 2,048   |
| <b>Discrete Output Points - %Q</b>  | 2,048   |
| <b>Discrete Global Memory - %G</b>  | 1,280 bits  |
| <b>Internal Coils - %M</b>  | 4,096 bits  |
| <b>Output (Temporary) Coils - %T</b>  | 256 bits  |
| <b>System Status References - %S</b>  | 128 bits (%S, %SA, %SB, %SC - 32 bits each)   |
| <b>Register Memory - %R</b>   | Starting with firmware Release 9.0, configurable in 128 word increments from 128 to 16,384 words with Logicmaster and from 128 to 32,640 words with Control version 2.2. For firmware prior to Release 9.0, fixed size is 9,999 words.                                |
| <b>Analog Inputs - %AI</b>  | Starting with firmware Release 9.0, configurable in 128 word increments from 128 to 16,384 words with Logicmaster and from 128 to 32,640 words with Control version 2.2. For firmware prior to Release 9.0, fixed size is 9,999 words.                                |
| <b>Analog Outputs - %AQ</b>   | Starting with firmware Release 9.0, configurable in 128 word increments from 128 to 16,384 words with Logicmaster and from 128 to 32,640 words with Control version 2.2. For firmware prior to Release 9.0, fixed size is 9,999 words.                                |
| <b>System Registers (for reference table viewing only; cannot be referenced in logic program)</b> | 28 words (%SR)  |
| <b>Timers/Counters</b>  | >2,000  |
| <b>Shift Registers</b>  | Yes   |
| <b>Built-in Serial Ports</b>  | 1 (uses connector on PLC power supply). Supports SNP slave and SNP-X slave protocols. Requires CMM module for SNP/SNPX master, CCM, or RTU slave protocol support; PCM module for RTU master support.   |
| <b>Communications</b>   | LAN- Supports multidrop. Also supports Ethernet, FIP, Profibus, GBC, GCM, and GCM+ option modules.  |
| <b>Override</b>   | Yes   |
| <b>Battery Backed Clock</b>   | Yes   |
| <b>Interrupts</b>   | Yes   |
| <b>Type of Memory Storage</b>   | RAM and Flash   |
| <b>PCM/CCM Compatibility</b>  | Yes   |
| <b>Floating Point Math Support</b>  | Yes, firmware-based in firmware Release 9.0 and later.  |

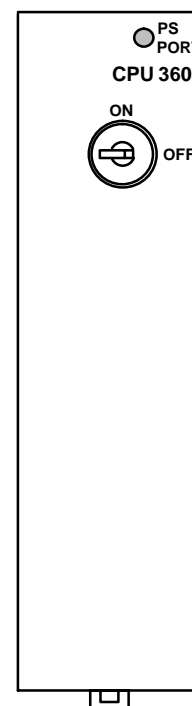

# CPU363

Catalog Number IC693CPU363

|  |   |
|--|---|
| <b>CPU Type</b>  | Single slot CPU module  |
| <b>Total Baseplates per System</b>   | 8 (CPU baseplate + 7 expansion and/or remote)   |
| <b>Load Required from Power Supply</b>   | 890 milliamps from +5 VDC supply  |
| <b>Processor Speed</b>   | 25 MegaHertz  |
| <b>Processor Type</b>  | 80386EX   |
| <b>Operating Temperature</b>   | 0 to 60 degrees C (32 to 140 degrees F) ambient   |
| <b>Typical Scan Rate</b>   | .22 milliseconds per 1K of logic (boolean contacts)   |
| <b>User Memory (total)</b>   | 240K (245,760) Bytes. Actual size of available user program memory depends on the amounts configured for %R, %AI, and %AQ configurable word memory types (see below).                             |
| <b>Discrete Input Points - %I</b>  | 2,048   |
| <b>Discrete Output Points - %Q</b>   | 2,048   |
| <b>Discrete Global Memory - %G</b>   | 1,280 bits  |
| <b>Internal Coils - %M</b>   | 4,096 bits  |
| <b>Output (Temporary) Coils - %T</b>   | 256 bits  |
| <b>System Status References - %S</b>   | 128 bits (%S, %SA, %SB, %SC - 32 bits each)   |
| <b>Register Memory - %R</b>  | Configurable in 128 word increments from 128 to 16,384 words with Logicmaster and from 128 to 32,640 words with Control version 2.2.  |
| <b>Analog Inputs - %AI</b>   | Configurable in 128 word increments from 128 to 16,384 words with Logicmaster and from 128 to 32,640 words with Control version 2.2.  |
| <b>Analog Outputs - %AQ</b>  | Configurable in 128 word increments from 128 to 16,384 words with Logicmaster and from 128 to 32,640 words with Control version 2.2.  |
| <b>System Registers</b> (for reference table viewing only; cannot be referenced in user logic program) | 28 words (%SR)  |
| <b>Timers/Counters</b>   | >2,000  |
| <b>Shift Registers</b>   | Yes   |
| <b>Built-in Ports</b>  | Three ports. Supports SNP/SNPX slave (on power supply connector). On Ports 1 and 2, supports SNP/SNPX master/slave and RTU slave. Requires CMM module for CCM; PCM module for RTU master support. |
| <b>Communications</b>  | LAN- Supports multidrop. Also supports Ethernet, FIP, Profibus, GBC, GCM, GCM+ option modules.  |
| <b>Override</b>  | Yes   |
| <b>Battery Backed Clock</b>  | Yes   |
| <b>Interrupt Support</b>   | Supports the periodic subroutine feature.   |
| <b>Type of Memory Storage</b>  | RAM and Flash   |
| <b>PCM/CCM Compatibility</b>   | Yes   |
| <b>Floating Point Math Support</b>   | Yes, firmware-based in firmware Release 9.0 and later.  |

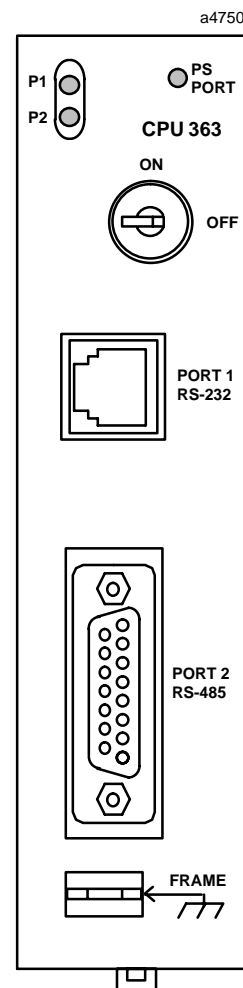

# CPU364

Catalog Number IC693CPU364

|   |  |
|---|--|
| <b>CPU Type</b>   | Single slot CPU module with embedded Ethernet Interface  |
| <b>Total Baseplates per System</b>  | 8 (CPU baseplate + 7 expansion and/or remote)  |
| <b>Load Required from Power Supply</b>  | 1.51 Amps from +5 VDC supply   |
| <b>Processor Speed</b>  | 25 MegaHertz   |
| <b>Processor Type</b>   | 80386EX  |
| <b>Ethernet fuse, replaceable</b>   | 2.69x2.69x6.1 mm, 125V, 1A, slow acting  |
| <b>Operating temperature</b>  | 0 to 60 degrees C (32 to 140 degrees F) ambient  |
| <b>Typical Scan Rate</b>  | .22 milliseconds per 1K of logic (boolean contacts)  |
| <b>User Memory (total)</b>  | 240K Bytes. Note: Actual size of available user program memory depends on the amounts configured for %R, %AI, and %AQ configurable word memory types (see below).  |
| <b>Discrete Input Points - %I</b>   | 2,048  |
| <b>Discrete Output Points - %Q</b>  | 2,048  |
| <b>Discrete Global Memory - %G</b>  | 1,280 bits   |
| <b>Internal Coils - %M</b>  | 4,096 bits   |
| <b>Output (Temporary) Coils - %T</b>  | 256 bits   |
| <b>System Status References - %S</b>  | 128 bits (%S, %SA, %SB, %SC - 32 bits each)  |
| <b>Register Memory - %R</b>   | Configurable in 128 word increments from 128 to 16,384 words with Logicmaster and from 128 to 32,640 words with Control version 2.2.   |
| <b>Analog Inputs - %AI</b>  | Configurable in 128 word increments from 128 to 16,384 words with Logicmaster and from 128 to 32,640 words with Control version 2.2.   |
| <b>Analog Outputs - %AQ</b>   | Configurable in 128 word increments from 128 to 16,384 words with Logicmaster and from 128 to 32,640 words with Control version 2.2.   |
| <b>System Registers</b> (for reference table viewing only; cannot be referenced in logic program) | 28 words (%SR)   |
| <b>Timers/Counters</b>  | >2,000   |
| <b>Shift Registers</b>  | Yes  |
| <b>Built-in Serial Ports</b>  | 1 (uses connector on PLC Power Supply). Supports SNP/SNPX slave. Requires CMM module for SNP/SNP-X master, RTU slave, or CCM; PCM module for RTU master support.   |
| <b>Communications</b>   | <i>Ethernet</i> (internal) – AAUI or 10BASE-T. AAUI requires external transceiver. 10BASE-T is direct.<br><i>Ethernet</i> (additional) – Supports Ethernet option modules. LAN Requires option modules for Genius, Profibus, FIP |
| <b>Override</b>   | Yes  |
| <b>Battery Backed Clock</b>   | Yes  |
| <b>Interrupt Support</b>  | Supports the periodic subroutine feature.  |
| <b>Type of Memory Storage</b>   | RAM and Flash  |
| <b>PCM/CCM Compatibility</b>  | Yes  |
| <b>Floating Point Math Support</b>  | Yes, firmware-based.   |

Note: On some early modules, the LED labeled "PS PORT" may say "SNP" instead; otherwise, the modules are identical.

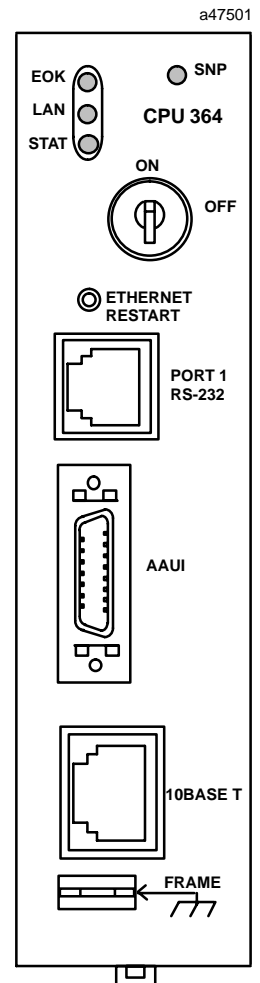

# Chapter 6

## Memory Backup and Backup Battery

efesotomasyon.com

### Backup Battery for RAM Memory (All Supplies)

The long-life Lithium battery (IC693ACC301) used to maintain the contents of the CMOS RAM memory in the CPU is accessed by removing the cover plate located at the bottom of the power supply faceplate. This battery is mounted on a plastic clip attached to the inside of this cover.

The battery is wired to a small Berg female connector that connects to either of the two Berg male connectors mounted on the Power Supply printed circuit board. This battery can be replaced with power applied to the PLC.

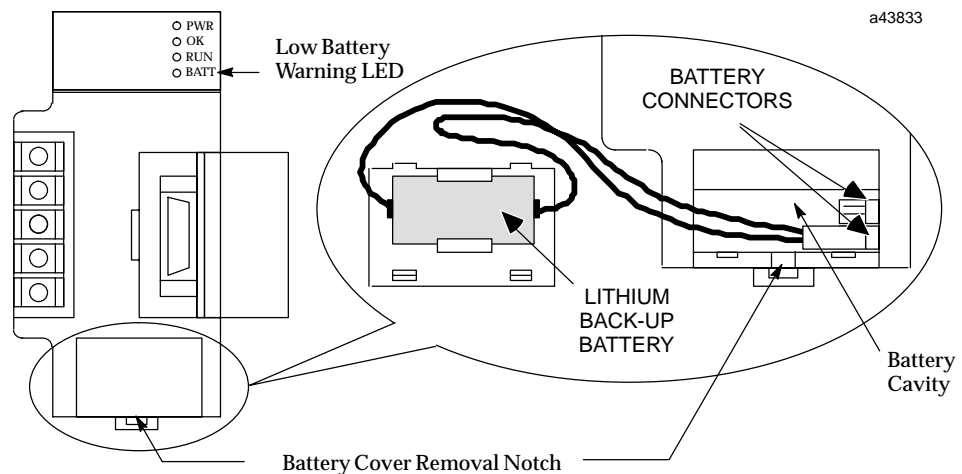

Figure 6-1. Backup Battery for RAM Memory

### Caution

**If a Low Battery Warning (BATT LED turns ON) occurs, replace the battery located in the power supply *before* removing power from the rack. Otherwise, there is a possibility that data will be corrupted or the application program will be cleared from memory.**

## Battery Replacement Instructions

### Warning

**To avoid the chance of losing the contents of RAM memory, you can carefully perform the following steps with PLC power ON. This procedure should only be performed by qualified electrical personnel who are trained in applicable electrical safety rules and procedures. Failure to follow standard electrical safety practice can result in injury or death to personnel, damage to equipment, or both.**

- Carefully insert the tip of a small pocket-size screwdriver approximately 1/4 inch (6 mm) into the battery cover removal slot, located beneath the battery cover (see previous figure).
- Gently rotate the screwdriver about 45 degrees to loosen the cover.
- Remove cover with fingers. The battery is mounted in a clip on the back of the cover. It has a pair of leads with a connector that is plugged-in to a connector on a circuit board inside the power supply.
- Carefully reach into battery cavity with your fingers (do not use a metal object to do this) and unplug the battery connector.
- Remove the old battery from the clip on the battery cover and set it aside. Be careful not to mix it up with the new battery.
- Carefully reach into battery cavity with your fingers (do not use a metal object to do this) and plug in new battery connector.
- Clip new battery into clip on battery cover.
- Snap battery cover back onto power supply.

## Battery Replacement/Memory Protection Factors

Since there are differences in each PLC application, each user will have to determine on an individual basis what strategy to use. There are several factors to consider when planning a battery replacement/memory protection strategy:

- How critical is the application? Will considerable loss be sustained if the PLC goes down? If so, frequent replacement of the battery would be a wise choice. For critical applications, the cost of a battery would be quite low in comparison to the cost of a PLC shut-down.
- How readily can a backup program be loaded? Are there technicians on-site who know how to load a backup program? Is the backup program accessible at all times to those responsible for maintaining the equipment? Is a personal computer or equivalent equipped with GE Fanuc programming software available at all times for use in loading the backup program?
- Do you have a preventive maintenance program? A formal program would help ensure that the battery is replaced on time. Some users replace the backup battery each year during their annual shut-down period.
- How accessible is the PLC? In some applications, the PLC may be mounted in a remote location that is not easily accessed.
- Safety codes. Some users may have safety rules that would not allow replacing the battery with power applied.
- How is the PLC used? Is power left on all the time, or is it shut down every day? See the heading "Factors Affecting Battery Life."
- Some users run without a backup battery by using one of the PROM options. See the section below called "Operating Without a Memory Backup Battery" to determine if this strategy is suitable for your application.

## The Importance of Backing up your Program

Experience has shown that regardless of what strategy you use to maintain PLC memory, you should, additionally, always keep an up-to-date backup copy of your application program. The effort required to create and maintain a backup copy is very small compared to the work required to reprogram, or re-key from hardcopy, your entire application if, due to some misfortune, it was lost. Other suggestions to help minimize down time:

- Make sure the backup copy is readily accessible to those who may need to use it.
- Train more than one person to load the backup program in case that one person is not available when needed. Information on creating a backup can be found in GE Fanuc's software user's manuals. This procedure is also covered in applicable GE Fanuc programming software training courses.
- Ensure that a suitable computer (usually a laptop type) is equipped with GE Fanuc PLC programming software and will be readily available to load the backup program to the PLC.
- Create a written backup procedure. Fortunately, restoring your program from the backup copy is probably not something you will do very often. As a result, however, some of the steps could easily be forgotten.

## Factors Affecting Battery Life

Replacing your battery once per year is a good rule of thumb. However, no one can predict precisely how long a backup battery will last because this depends upon what CPU is used, what temperature it is subjected to, and how it used. Considering the following list of factors that affect battery life will help you decide how frequently to replace the battery in your application:

- A battery that is not in use has an estimated life (called its "shelf life") of 5 years at "room temperature" (25 degrees C, or 77 degrees F).
- A battery that is used continuously (supplying current to memory circuits with PLC power off) has an average estimated life of one year for CPU models 331 and above, and 2 years for CPU models 311, 313 and 323, if used at room temperature.
- As long as a PLC is powered up, its battery is not being used; so how often you power down your PLC has a direct affect on battery life. Some users keep their PLC powered up all of the time while others turn theirs off every night.
- Temperature has a relatively large affect on battery life. Temperatures considerably above room temperature (25 degrees C, or 77 degrees F), or below freezing (0 degrees C, or 32 degrees F) will appreciably shorten battery life.
- The type of CPU has a small affect on battery life. Some CPUs have more memory than others. Also, some CPUs have a clock and some do not. More memory requires more battery current to maintain its contents; and a clock requires battery current to maintain its operation.

## Low Battery Warning Methods

There are three basic ways that the PLC warns of a low battery:

- The red "BATT" LED on the Power Supply module lights when the battery is low. The disadvantage of this method is that the PLC is often mounted in an enclosure, so this LED might not be easily seen.
- The PLC Fault Table is updated with a battery low message. Viewing the PLC Fault Table requires that a programmer be connected to the PLC.
- Certain System Reference bits are set to logic 1 when the battery is low. These are %SA011 (LOW\_BAT), %SC009 (ANY\_FLT), %S010 (SY\_FLT), and %SC012 (SY\_PRES). The most specific is %SA011 (LOW\_BAT). This bit could be used as a contact in your ladder logic program to turn on an output that controls a warning light on an operator panel (as in the example rung below), or to send a warning to an operator interface terminal.

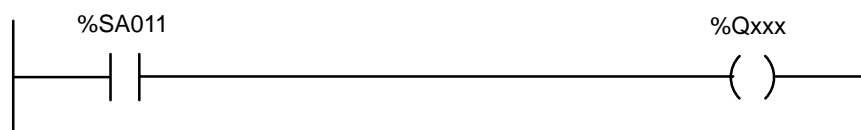

In the rung shown above, the %SA011 contact will close when a low battery is detected by the PLC. This will turn on the %Q output coil, which addresses an output module's output that will turn on a warning light. An alternate method would be to communicate the status of the coil (which, in that case, would probably be a %M coil) to a Human to Machine Interface (HMI) terminal such as a GE Fanuc CIMPLICITY HMI unit. The HMI could be programmed to display a warning message when that

particular bit goes to a logic 1. For more information about System Reference bits and ladder logic programming, see the the *Series 90-30/20/Micro PLC CPU Instruction Set Reference Manual*, GFK-0467.

## Operating Without a Memory Backup Battery

Whether it would be to your advantage to use a battery-less scheme depends on your application. There are various advantages and disadvantages to consider in making your decision.

### Possible Advantage

The obvious advantage of operating without a memory backup battery is that you are freed from the need to maintain the battery. To be able to run without a battery, you need to have a PROM device – either an EPROM, EEPROM, or Flash PROM – installed in your system. These devices can store program logic, configuration, and register values without the need for a backup battery, and you can configure your CPU to read the contents of PROM into RAM memory each time the PLC is powered up.

### Possible Disadvantages

Information is not stored to your PROM device automatically. To store information, you must stop the PLC, then use a programming device to tell the CPU to write the current PLC (RAM) memory contents to the PROM device. This requirement may make battery-less operation undesirable for many users. For example, in many applications, important data is gathered and stored in RAM register memory, data such as the current level of material in a tank that is being filled, or a running count of parts produced, etc. This constantly changing data is not being copied automatically to the PROM device. It only exists in RAM memory. Therefore, if power is lost and there is no RAM memory backup battery, this data will be lost.

However, one way to preserve data in a battery-less system is to send it over a network to a computer that can store the data on its hard drive. Also, static data (data that doesn't change) contained in RAM memory, such as mathematical constants or look-up table type information, can be stored initially in PROM and automatically written back to RAM each time the PLC powers up.

Another consideration is that if you change your program (or configuration), someone will have to remember to write the changed information to the PROM device. If that step is forgotten, then the change only exists in RAM memory, and in a battery-less system, it will be lost the next time power is removed from the PLC.

### Configuring a Battery-Less System

Here are the basic steps to configure a system to run battery-less:

- Equip your CPU with a PROM device. On some CPUs a PROM device is purchased as an option; on others, it is a standard feature. The CPU chapter of this manual has a table that identifies the standard PROM configuration for each CPU.
- There are three CPU configuration parameters involved. Configure them as follows: **Pwr Up Mode:** RUN; **Logic/Cfg:** PROM; **Registers:** PROM.
- Store your folder (include Program Logic, Configuration, and Register Data) to the PLC. This places your entire folder into RAM (working) memory.

- Write PLC (RAM) memory to the PROM device. Make sure you write all data (Program Logic, Configuration, and Register Data) to the PROM. Note that the type of PROM device depends on what model CPU you have and how it is equipped.
- If you are using a 340 or higher CPU (such as a CPU350, CPU351, etc.), read the next section for an additional requirement.

When configured this way, the contents of PROM memory will be written into RAM memory each time the PLC powers up.

### Operation Without a Memory Backup Battery Using a 340 or Higher CPU

This information is applicable only to CPU model numbers 340 and higher (such as CPU350, CPU351, etc.). In systems that do not use a memory backup battery, a standard 0.1" Berg jumper should be installed across either of the two power supply battery connectors to ensure reliable restarting of the CPU after a power cycle. This jumper should not be installed if a battery is plugged into either the power supply or CPU battery connector.

## Determining Battery Age Using Battery Date Code

Battery age can be determined from the date code stamped on the battery.

The battery, manufactured by Panasonic, will have a four-digit date code. It will be something like 5615 or 7Y34. Use the following information to determine the date of manufacture.

- First digit shows the year in a rotating 10-year cycle. For example, 0=1990, 1=1991, 2=1992 ... 9=1999, 0=2000, 1=2001, 2=2002, etc. This seeming duplication should not be a problem because the shelf life of these batteries is 5 years. Batteries in inventory that are older than 4 years old should be discarded according to the manufacturer's instructions (since they have less than one year of life remaining we would not recommend using them in a PLC). This will ensure that outdated batteries are not mistaken for newer batteries.
- Second digit shows the month. 1=January, 2=February, 3=March, 4=April, 5=May, 6=June, 7=July, 8=August, 9=September, O=October, Y=November, Z=December.
- Third digit shows the week of the month.
- Fourth digit shows the day of the week. 1=Monday, 2=Tuesday, 3=Wednesday, 4=Thursday, 5=Friday, 6=Saturday, 7=Sunday.

For example, the code 7612 is interpreted as:

Manufactured on June 3, 1997

## RAM Memory Battery Backup Connection Path

CMOS RAM memory is a volatile type of memory, which means that it can lose its contents (ladder program, configuration, etc.) if power is removed. To retain RAM memory contents under no-power conditions, a long-life lithium battery is provided. This battery is normally mounted in the rack's Power Supply module. To avoid accidental disconnection of the memory backup battery, it is beneficial to know the connection path between the battery and the memory circuits:

**For embedded CPUs:** The battery connection path to RAM memory is through the Power Supply's baseplate connector and across the backplane board to the RAM circuits.

**For modular CPUs:** The battery connection path to RAM memory is through the Power Supply's baseplate connector, across the backplane board, and through the CPUs baseplate connector to the RAM circuits inside the CPU module.

Obviously, removing the Power Supply module from the PLC breaks the connection between the backup battery and the RAM memory circuits for both embedded and modular CPUs. Also, in a modular CPU system, removing the CPU module would disconnect the backup battery from the memory circuits. ***In addition, to avoid the possible problems associated with losing the contents of RAM memory, we recommend that you maintain an up-to-date backup copy of your program folder.*** Instructions for creating program folder backups can be found in the *Logicmaster 90, Series 90-30 Programming Software User's Manual*, GFK-0466, *Control User's Guide*, GFK-1295, and *VersaPro Programming Software User's Guide*, GFK-1670.

### Super Capacitor Memory Backup

Besides the backup battery, the RAM memory circuits in both Embedded and Modular CPUs are further protected by a "super capacitor," which can store enough charge to maintain memory for a short time if the battery is disconnected. The amount of protection time provided by the super capacitor depends on the following:

- The PLC power supply supplies 5 VDC to the memory circuits, including the super capacitor. Therefore, when PLC power is turned off, the super capacitor has an initial 5 VDC charge. If the battery is also disconnected shortly after PLC power is turned off, the super capacitor will begin discharging from the 5 VDC level until its charge reaches 2 VDC, at which time memory contents will be lost. When used this way, the super capacitor can maintain memory contents for a minimum of 1 hour.
- The memory backup battery supplies 3 VDC to the memory circuits, including the super capacitor. Therefore, if PLC power has been turned off for an hour or more and only the battery is powering the memory circuits, the super capacitor has a 3 VDC charge. Then, if the battery is disconnected, the super capacitor will begin discharging from the 3VDC level until its charge reaches 2 VDC, at which time memory contents will be lost. When used this way, the super capacitor can maintain memory contents for a minimum of 20 minutes.

## Maintaining RAM Memory During Storage or Shipment of a CPU

### Modular CPUs

Modular CPUs have an internal connector for a backup battery so that RAM memory contents can be retained while the CPU is being stored or shipped. This arrangement should not to be used when the CPU module is installed in the baseplate and the backup battery is installed in the power supply. To use a backup battery in the CPU module, it is necessary to remove the front cover of the CPU module. This can be accomplished by following these steps:

- To avoid losing memory contents once the CPU is removed from the PLC, we recommend you install the backup battery into the CPU within 20 minutes. First, make sure PLC power is off, then remove the CPU module.
- Gently squeeze the front cover of the CPU module and pull it forward, away from the module case, while gently pressing in on the 4 front cover tabs sequentially with

a small screwdriver. The front cover tabs latch into holes on each side of the module case (refer to Figure 2-1 for location of front cover holding tabs).

- After removing the front cover, plug the memory backup battery into the two-prong battery connector on the front of the CPU module's printed circuit board.
- While the battery is connected to the CPU, you will have to leave the CPU's front cover off. Also, the battery should be temporarily secured to the module with cable ties or tape to keep it from being accidentally damaged or disconnected.

The Battery Accessory Kit, described below, may also be used on a Modular CPU baseplate if the power supply has to be removed. This would require leaving the CPU module mounted in the baseplate.

### Embedded CPUs

Embedded CPU Models 311, 313, and 323 can be stored or shipped with a power supply installed and the power supply battery connected in order to maintain the contents of RAM memory. However, another option (that doesn't require the use of a power supply) is to use the Battery Accessory Kit, described next.

### Battery Accessory Kit (IC693ACC315)

The Battery Accessory Kit (IC693ACC315) lets you maintain RAM memory contents without using a power supply. It is useful for maintaining memory contents while a baseplate is being stored or shipped. The Battery Accessory Kit consists of a battery with an attached connector mounted on a circuit board. The circuit board has a connector that plugs into the power supply backplane connector (see the figure below). The Battery Accessory Kit can be used on either Embedded or Modular Series 90-30 CPU baseplates.

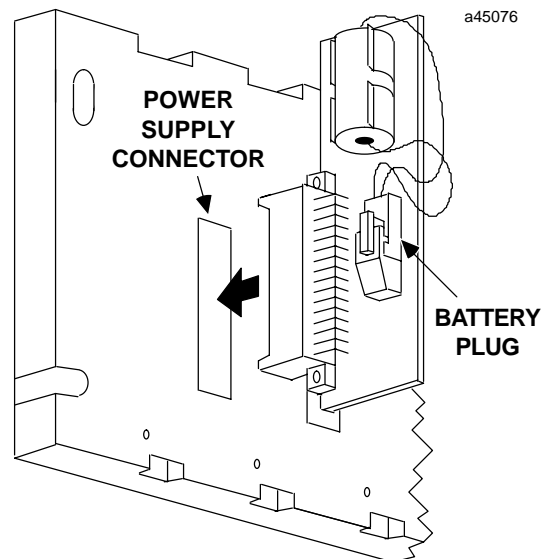

Figure 6-2. Installing the Battery Accessory Kit

## Battery Accessory Kit Installation

1. Insert the plug on the end of the battery cable into the 2-pin connector on the Battery Accessory board. The battery plug is normally not plugged into the accessory connector. This prevents accidental discharge of the battery during storage and handling.
2. Align the backplane connector on the Battery Accessory board with the power supply connector on the baseplate backplane. Push the Battery Accessory board toward the baseplate until it is fully seated. See the figure above.
3. If the baseplate is to be shipped with the Battery Accessory board installed, ensure that the board is held in place by packing material or cable ties. The cable ties can be installed in holes provided on both ends of the accessory board and secured to the baseplate.

### Caution

**To avoid losing CPU data, the Battery Accessory must be installed within 1 hour after turning off PLC power, or 20 minutes after removing the memory backup battery. See the section “Super Capacitor Memory Backup” section for details.**

**When the Battery Accessory is removed, a power supply module with a good battery must be installed and/or input power applied within 20 minutes to avoid losing CPU data. See the section “Super Capacitor Memory Backup” section for details.**

## Batteries in Power Supplies on Expansion or Remote Racks

Batteries in power supplies on Expansion or Remote racks, are not in use. Only the battery in a CPU rack supplies backup power to RAM memory. Batteries in non-CPU racks may be removed and used as spares, if they meet the age requirements stated previously in this chapter.

# Chapter 7

## Input and Output Modules

[efesotomasyon.com](http://efesotomasyon.com)

---

---

The basics of the Series 90-30 Input and Output (I/O) modules are covered in this chapter for your convenience. A table listing these modules is located at the end of this chapter. For detailed specifications and installation instructions, please refer to publication GFK-0898, *Series 90-30 PLC I/O Module Specifications*. **This chapter also contains a preliminary description of the IC693DVM300 Digital Valve Driver Module.**

### Basic I/O Module Types

#### ■ Discrete Input

Series 90-30 discrete input modules convert AC and DC power levels from user devices to the logic levels required by the PLC. An optical coupler provides isolation between the incoming power and the logic circuitry. Discrete input modules are available that have 8, 16, or 32 points.

#### ■ Discrete Output

Series 90-30 discrete output modules convert logic levels into AC or DC power levels required for driving user supplied devices. Either a power semiconductor or an electromagnetic relay switches each output point. The discrete output semiconductor-switched modules are available with 5, 8, 12, 16, or 32 output points. Relay output modules are available with either 8 or 16 Normally Open relay contact outputs.

#### ■ Discrete Input/Output

Combination discrete input/output modules combine AC inputs and relay outputs or DC inputs and relay outputs on one module. Each of these modules have 8 input circuits and 8 relay output circuits on one board.

#### ■ Analog Input

Series 90-30 analog input modules provide A/D (Analog to Digital) conversion by converting an analog input signal into a scaled digital number which will be transferred into the PLC's %AI memory. Analog input modules are provided in four versions, (1) a 4-channel current module, (2) a 4-channel voltage module, (3) a 16-channel high-density current input module, and (4) a 16-channel high-density voltage input module.

#### ■ Analog Output

Series 90-30 analog output modules provide D/A (Digital to Analog) conversion by converting a scaled digital number (from the PLC's %AQ memory) into an analog output voltage. Analog output modules are provided in three versions, (1) a 2-channel current module, (2) a 2-channel voltage module, and (3) a high-density current/voltage module with 8 analog output channels.

- **Analog Combination Module**

An analog combination module provides 4 A/D input channels and 2 D/A output channels on one module. Each of the input and output channels can be configured individually for current or voltage mode.

- **Third-Party Modules**

In addition to the modules discussed in this chapter, numerous third-party I/O modules (and other hardware and software products) for the Series 90-30 PLC are available to meet a wide variety of needs. Third-party companies that meet GE Fanuc's standards may apply for recognition under the GE Fanuc Accompany Program. Details on this program are found in the GE Fanuc Automation Solutions Catalog, or on the GE Fanuc web site, both listed below. For information on third-party modules, consult the following:

- Your GE Fanuc PLC distributor or sales engineer
- The GE Fanuc web site at <http://www.gefanuc.com>
- The GE Fanuc *Automation Solutions Catalog*, GFW-0067

## Discrete I/O Modules

### Discrete I/O Module Point Density

There are two density categories for these modules:

- **Standard Density Modules:** Standard density modules have up to 16 circuits (also called “points”) per module. These modules are equipped with a removeable terminal board. See the following figure.
- **High Density Modules:** High density modules have 32 circuits per module. These modules have either a 50-pin connector, or two 24-pin connectors mounted on their faceplates. Connection choices are discussed later in this chapter.

### Standard Density Discrete I/O Module Features

Standard Density(16 points or less) Modules have the following features (refer to the following figure):

- **Removeable Terminal Board.** You can remove the terminal board from the module in order to wire it, if desired. Then, when you are finished wiring it, you can easily reinstall it on the module. However, some prefer to leave it on the module when wiring. If you ever need to replace a module, you don't have to do any rewiring if your old terminal board is still in good condition. Simply remove the wired terminal board from the old module and install it on the new module. The terminal board screw terminals are also convenient points for measuring voltages while testing or troubleshooting.
- **Hinged Front Cover.** The cover is easily opened to access the terminal board connections. Normally it's kept closed to protect personnel from accidentally touching a hot terminal. Note in the following figure that the back side of the front cover insert contains a schematic diagram of the terminal board connections. The module catalog number (IC693MDL940 in the example shown) is printed on the bottom of the front cover insert. The module catalog number is also printed on the label on the side of the module. However, in order to see this side label, the module has to be removed from the PLC

On the front side of the front cover insert are lines that correspond to the module's I/O points. You can temporarily remove the insert and write the signal name for each point on the appropriate line, as shown in the example in the figure.

Also on the front side of the front cover insert, running vertically on the left edge of the insert, is a color bar that identifies the type of module: Blue = DC, Red = AC, and Gray = Analog.

- **Module Lens Cap.** Located on the top front of the module, it covers the LED (Light Emitting Diode) status lights. These are labeled in the following figure in two groups, A1 through A8, and B1 through B8. Since this is a figure of a 16-Point Output module, there are 16 LED status lights. (The number of status lights on any given module is a function of the number of circuits points on that module.) If you compare these status lights to the connection diagram on the back of the hinged cover, you will notice that the outputs on this module are in two groups, labeled A1–A8 and B1–B8, that correspond to the A and B rows of status LEDs. Note the additional LED on the right side of the lens cap that is labeled with the letter F. This

is a blown fuse indicator light. This letter F is present on all of the discrete I/O module lens caps, but is only functional on certain Output Modules that have internal fuses. It only lights if an internal fuse is blown. A table with a list of modules having fuses as well as other details about the status LEDs is provided in Chapter 13 of this manual.

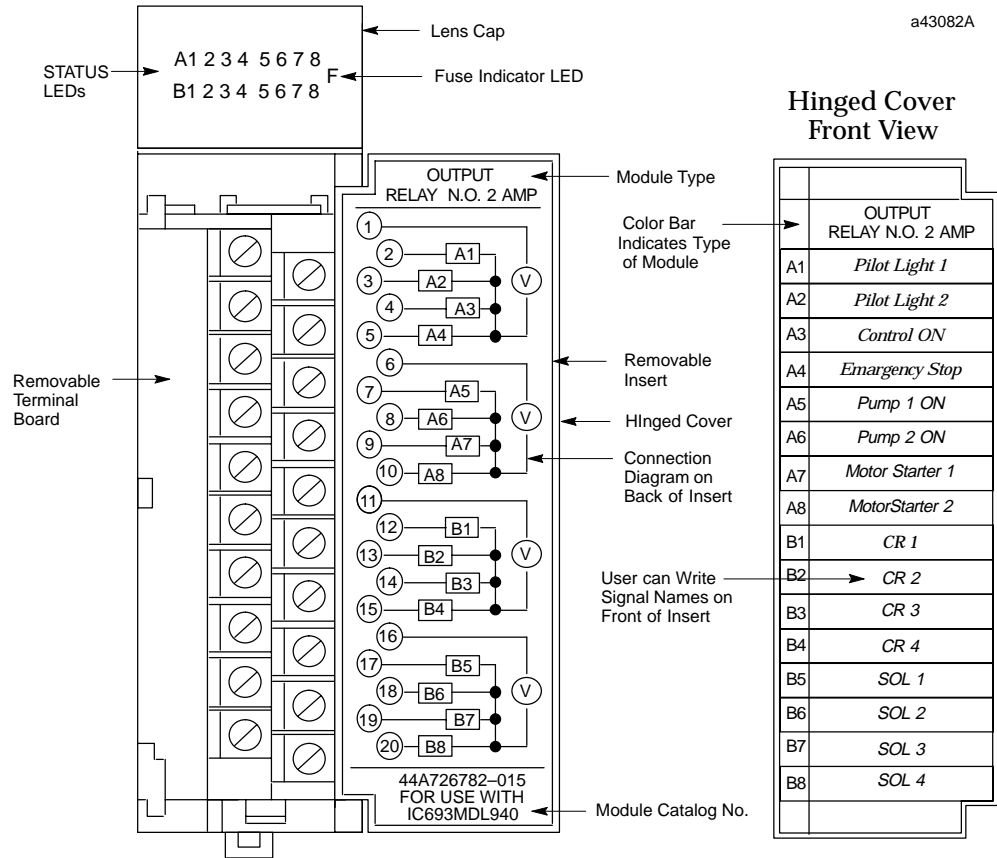

Figure 7-1. Example of Series 90-30 Standard Density Discrete Output Module

---

## Wiring Standard Density (16-Point or Less) Discrete Modules

There are three basic wiring methods:

- **Direct Method.** Run the wires from the field devices (switches, relays, etc.) directly to the screws on the modules' terminal boards.
- **Terminal Strip Method.** Mount a terminal strip inside the control enclosure and wire from the terminal strip to the modules' terminal boards. Then wire field devices to the terminal strip.
- **Terminal Block Quick Connect Assembly Method.** The Terminal Block Quick Connect Assembly has three pieces: a faceplate, a cable, and a terminal block. The faceplate snaps onto an I/O module in place of its normal terminal board. This faceplate has a connector that mates with the cable. In turn, the cable plugs into a connector on the terminal block. The terminal block mounts on a DIN-rail in a convenient place in your enclosure. The terminal block is used for connecting to field devices such as switches and relays. This method saves, on the average, over two hours of wiring time per module when compared with the Terminal Strip method. For more information, see Appendix J, "Terminal Block Quick Connect Components."

## Discrete Relay Output Module Protection

Output points on discrete relay output modules that switch an inductive load such as a relay coil, lamp filament, or solenoid coil should have external protection. This is usually in the form of an R-C (Resistor-Capacitor) network across an AC load, or a reverse-biased diode across a DC load. Please see GFK-0898, *Series 90-30 PLC I/O Module Specifications*, for details.

## High Density (32-Point) Discrete Module Features

- There are two types of these modules. One type has a single 50-pin connector on its faceplate, the other type has a pair of 24-pin connectors on its faceplate (see next two figures).
- The dual 24-pin type has LED status indicators. The 50-pin type does not. The LED status indicators are arranged in four groups of eight across, labeled A, B, C, and D. They are located at the top of the module (see next figure).
- 32-point modules are only available in 5, 12, and 24 VDC ratings.
- None of the 32-point modules are fused.
- These modules are useful in applications where a high count of DC I/O points is required. The maximum number of I/O points for a Series 90-30 system can be obtained by using a CPU that supports a total of eight 10-slot racks, and by populating the racks with 32-point modules. The theoretical maximum number of I/O points possible is calculated by adding the 9 available slots in the CPU rack (the CPU must occupy one slot) to the 70 slots in the seven 10-slot expansion or remote racks to get a total of 79 slots. Multiply 79 times 32 for a maximum of 2,528 I/O points (only CPUs 350 – 364 support this many I/O points). Of course, this assumes that every slot is populated with a 32-point I/O module. Most practical applications require that you use some slots for option modules, so the number of slots available for I/O modules will be reduced accordingly.

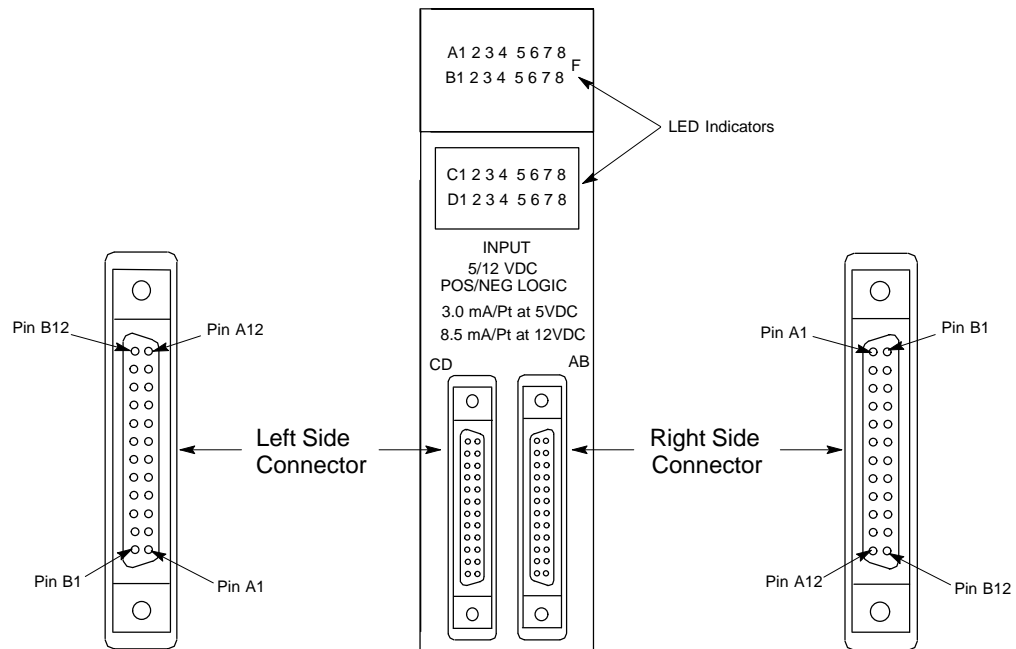

Figure 7-2. Example of 32-Point I/O Module (IC693MDL654) With Dual Connectors

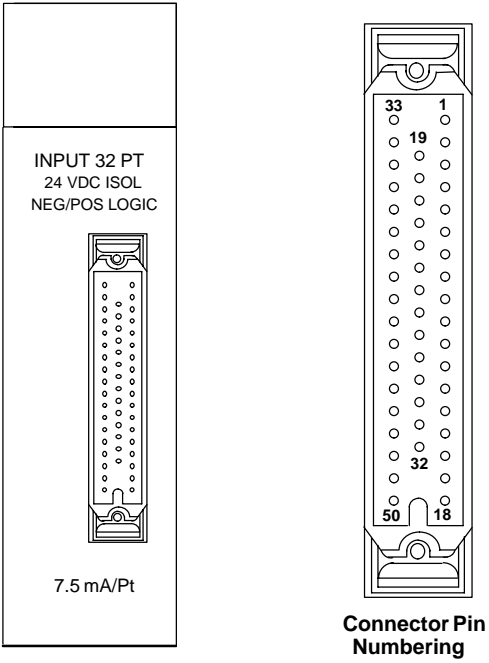

Figure 7-3. Example of 32-Point I/O Module (IC693MDL653) With Single Connector

## Wiring Methods for 32-Point Discrete I/O Modules

### Modules with Single 50-Pin Connector

Three choices are available for connecting these modules.

- Connect to a Weidmuller #912263 terminal block using one of the two GE Fanuc “extension” cables (see next figure). Cable IC693CBL306 is 3 feet (1meter) long. Cable IC693CBL307 is 6 feet (2 meters) long. Chapter 10, “Cables,” has details on these cables.
- Connect to a user-supplied terminal block/strip or I/O field devices using one of the two GE Fanuc “interface” cables. These cables have a 50-pin connector on one end that plugs into the module, and stripped, tinned leads on the other for wiring to a terminal block/strip or I/O field devices. Cable IC693CBL308 is 3 feet (1 meter) long, and cable IC693CBL309 is 6 feet (2 meters) long. These cables are useful if you have to run your wiring through conduit that is too small for a connector to fit through.
- Build a custom length cable. This is required if you need a cable longer than 6 feet (2 meters). See the IC693CBL308/309 data sheet in Chapter 10 for pin-out details.

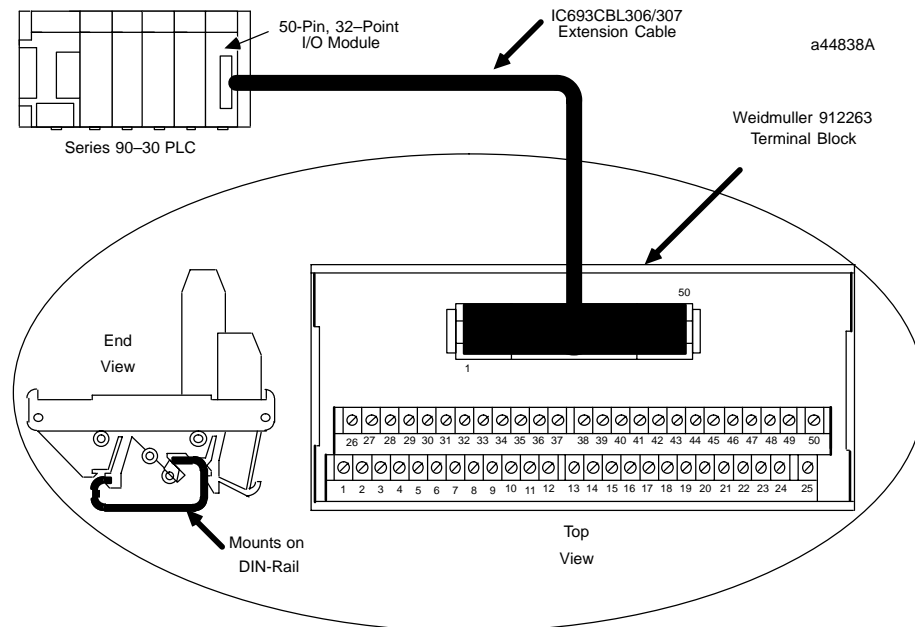

Figure 7-4. 50-PIN, 32 Point I/O Module Connection Method

---

## Modules with Dual 24-Pin Connectors

Three choices are available for connecting these modules

- Connect to a pair of Terminal Block Quick Connect (TBQC) terminal blocks (IC693ACC337) using a pair of GE Fanuc cables. Three lengths of cables are available: 20" (0.5 meter), 3 feet (1 meter), 6 feet (2 meters). The cables come in right hand and left hand types because the connectors on the modules are oriented differently (see figure 7-2). For details on the terminal blocks and cables, please see Appendix J.
- Connect to user supplied terminal block/strip or directly to I/O field devices using a pair of 10 foot (3 meter) GE Fanuc interface cables. These cables have 24-pin connectors on one end for connecting to the module, and stripped, tinned leads on the other for wiring to a terminal block/strip or I/O devices. Cable IC693CBL327 is for the left side and IC693CBL328 is for the right side. These cables are useful if you have to run your wiring through conduit that is too small for a connector to fit through, or if you need a cable longer than six feet. Chapter 10, "Cables," has details on these cables.
- Build a custom length cable. This is required if you need a cable longer than 10 feet (3 meters). See the IC693CBL327/328 data sheet in Chapter 10 for details on building custom length cables.

## Analog Module Features

Analog Modules have the following basic features (refer to the following figure):

- **Removeable Terminal Board.** You can remove the terminal board from the module in order to wire it, if desired. Then, when you are finished wiring it, you can easily reinstall it on the module. However, some prefer to leave it on the module when wiring. If you ever need to replace a module, you don't have to do any rewiring if your old terminal board is still in good condition. Simply remove the wired terminal board from the old module and install it on the new module if it is good condition. The terminal board screw terminals are also convenient points for measuring voltages while testing or troubleshooting.
- **Hinged Front Cover.** The cover is easily opened to access the terminal board connections. For normal operation, it is kept closed to protect personnel from accidentally touching a hot terminal. Note in the following figure that the back side of the front cover insert contains a schematic diagram of the terminal board connections. The module catalog number (IC693ALG391 in this example) is printed on the bottom of the front cover insert. The module catalog number is also printed on the label on the side of the module. However, in order to see this side label, the module has to be removed from the PLC

On the front side of the front cover insert are lines that correspond to the module's I/O points. You can temporarily remove the insert and write the signal name for each point on the appropriate line to aid in testing or troubleshooting.

Also on the front side of the front cover insert, running vertically on the left edge of the insert, is a colored line that identifies the type of module: Blue = DC, Red = AC, and Gray = Analog.

- **Module Lens Cap.** Located on the top front of the module, it covers the LED (Light Emitting Diode) OK status light. This light indicates the basic status of the module. For normal operation, the OK LED should be on.

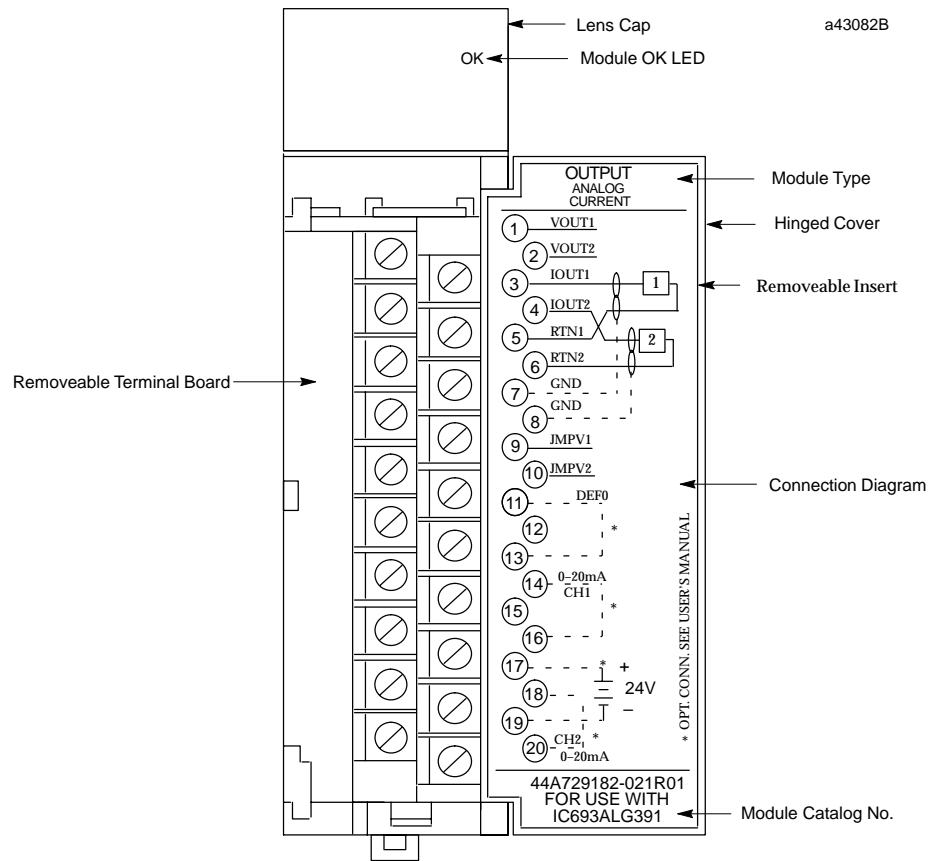

Figure 7-5. Example of Series 90-30 Analog Current Output Module

## Wiring Methods for Analog Modules

Twisted, shielded instrumentation cable is strongly recommended for analog module input or output signal connections. Proper grounding of the shield is also important. For maximum electrical noise suppression, the cable shield should only be grounded at one end of the cable. For Input modules, ground the end that is in the noisiest environment (which often is at the field device end). For Output modules, ground at the module end. See GFK-0898, *Series 90-30 PLC I/O Module Specifications*, for more shield grounding information.

## Analog Input Module Wiring Methods

Correcting electrical noise problems can sometimes be a trial-and-error routine. However, in general, it is generally best to ground the cable shield as close to the source of the noise as possible, which is usually at the device end. In troubleshooting noise problems, sometimes it is beneficial to experiment with the shield grounding point location. Remember, the cable shield should be grounded at one end only. Also, it is best to keep the length of stripped cable leads as short as possible to minimize the length of unshielded conductors that will be exposed to the noisy environment. See the *Series 90-30 PLC I/O Module Specifications Manual*, GFK-0898 for additional details.

- **Direct Method.** Run a shielded cable from the field device (transducer, potentiometer, etc.) directly to the module. Connect the conductors to the

applicable screws on the module's terminal board. Ground the shield at the field device end, exposing a minimum amount of conductor to the noisy environment. Do not connect the shield at the module end (insulate it with shrink tubing).

- **Terminal Strip Method.** Mount a terminal strip inside the control enclosure and run a shielded cable from the terminal strip to the module's terminal board terminals. Connect the shield to the metal panel next to the terminal strip. Do not connect the shield at the module end (insulate it with shrink tubing). Wire the field device to the terminal strip with a shielded cable, grounding the shield at the device end only (insulate the other end of the shield with shrink tubing). Also, keep the length of exposed leads at the terminal strip and device ends as short as possible.

### Note

**TBQC – The Terminal Block Quick Connect Assembly is not recommended for use with analog modules due to cable shielding requirements.**

## Analog Output Module Wiring

Each output should be connected using a good quality shielded wire with the shield grounded at the module end only. See GFK-0898, *Series 90-30 PLC I/O Module Specifications*, for more information.

## I/O Module Power Supply Current Draw

These values are found in Chapter 12 of this manual, which discusses how to calculate power supply loading. The information is also found in GFK-0898, *Series 90-30 PLC I/O Module Specifications*.

## I/O Module Wire Routing

To reduce noise coupling among PLC wires, it is recommended you keep electrically noisy wiring, such as AC power wiring and Discrete Output Module wiring, physically separated from low-level signal wiring such as connections to DC and Analog Input modules. This can be accomplished by grouping separately, where practical, the following categories of wiring:

- **AC power wiring.** This includes the AC input to the PLC power supply, as well as other AC devices in the control cabinet.
- **Analog Input and Output Module wiring.** This should also be shielded to further reduce noise coupling.
- **Discrete Output Module wiring.** These often switch inductive loads that produce noise spikes when switched off.
- **DC Input Module wiring.** Although suppressed internally, these low-level inputs should be further protected against noise coupling by observing these wiring practices.

---

## Grouping Modules to Keep Wires Segregated

If practical, grouping similar modules together in the PLC racks can help keep wiring segregated. For example, one rack could contain only AC modules and a different rack only DC modules, with further grouping in each rack by input and output types. For smaller systems, as an example, the left end of a rack could contain Analog modules, the middle could contain DC modules, and the right end could contain AC modules. Where AC or Output wiring bundles must pass near low-level signal wiring bundles, avoid running them beside each other. Route them so that, if they have to cross, they do so at a right angle. This will minimize coupling between them.

## IC693DVM300 Digital Valve Driver Module

This 4-channel digital valve driver module is capable of driving loads of up to 1.6 Amps at 24 VDC. Although it mounts in a standard Series 90-30 PLC slot, it does not connect to the PLC backplane. Its control power and output power come from an external supply. (The GE Fanuc IC690PWR124 stand-alone power supply would be a suitable choice.) This module is designed for TTL (5 Vdc) inputs.

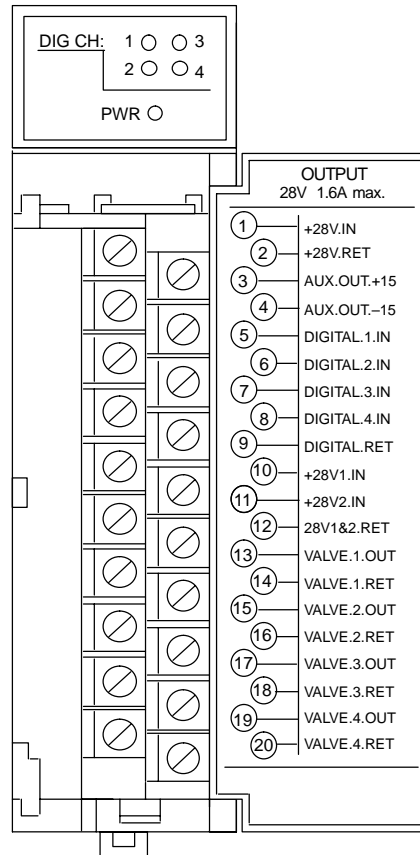

Figure 7-6. IC693DVM300 Digital Valve Driver Module

### Indicator LEDs

- **DIG CH: 1 - 4:** These light when their corresponding input is at a Logic 1 level.
- **PWR:** Lights to indicate the presence of +26 VDC (nominal) input power on terminals 1 and 2.

## DVM Specifications

Table 7-1. IC693DVM300 Specifications

| <b>OUTPUT CHARACTERISTICS</b>   |  |
|---|--|
| <b>Outputs (Channels) per Module</b>                                      | 4  |
| <b>Isolation</b>  | 2500 Vrms (optical isolation)  |
| <b>Nominal Output Voltage</b>   | 24 Vdc   |
| <b>Power Supply for Output Channels</b>                                   | 26 Vdc nominal, 21 Vdc minimum, 35 Vdc maximum   |
| <b>Output Current</b>   | 1.6 Amps maximum per channel<br>6.4 Amps maximum total per module  |
| <b>Output Voltage Drop (fully loaded)</b>                                 | 0.32 Vdc   |
| <b>Off state leakage current</b>  | 26 $\mu$ A at 26 Vdc operating voltage   |
| <b>Turn-on response time</b>  | < 1 $\mu$ S with resistive load  |
| <b>Turn-off response time</b>   | < 1 $\mu$ S with resistive load  |
| <b>Output protection (per channel)</b>                                    | Reversed-biased zener diode for free-wheeling inductive current. Also 36 Volt transorb for ESD and surge protection.             |
| <b>INPUT CHARACTERISTICS</b>  |  |
| <b>Input Voltage</b>  | 5 VDC (TTL) nominal, 12Vdc Maximum   |
| <b>Logic 1 Level</b>  | Logic 1: V > 3.5 Vdc<br>Logic 0: V < 0.7 Vdc   |
| <b>Input Current</b>  | 3.8 mA nominal   |
| <b>Input protection</b>   | 13.3 Volt transorb   |
| <b>AUXILIARY POWER SUPPLY OUTPUTS</b>                                     |  |
| <b>Voltage and Current</b>  | +15 VDC @ 0.3A and -15 VDC @ 0.2A  |
| <b>Isolation</b>  | Not isolated   |
| <b>MODULE POWER REQUIREMENTS</b>  |  |
| <b>Power Consumption</b> (Does not consume any power from PLC backplane.) | 5.6 Watts (with all outputs on) from external supply connected to terminals 1 and 2 (does not include power consumed by outputs) |
| <b>Input Voltage</b>  | +26 VDC nominal, 35 VDC maximum continuous   |

## Fuses

- Quantity 1 – Module control power. 1 Amp. Buss GDB-1A.
- Quantity 4 – One for each output. 2 Amps. Littlefuse 239002.

## DVM Connections

Table 7-2. IC693DVM300 Connections

| Pin No. | Signal Name     | Connection Description  |
|---------|-----------------|---|
| 1       | +28V.IN         | Module Control Power + input terminal (common on pin 2). Supplies power to module's signal-level circuits and auxiliary +15 and -15 Volt power supplies (pins 2, 3, and 4). Requires external 26 VDC (nominal) power supply |
| 2       | +28V.RET        | Common terminal for Module Control Power (pin 1).   |
| 3       | AUX.OUT.+1<br>5 | + 15 Vdc @ 0.3A Auxiliary power output for external circuits. Not isolated. Developed from input power on pins 1 and 2.   |
| 4       | AUTXOUT.-1<br>5 | - 15 Vdc @ 0.2A Auxiliary power output for external circuits. Not isolated. Developed from input power on pins 1 and 2.   |
| 5       | DIGITAL.1.IN    | Channel 1 TTL input connection (common on pin 9)  |
| 6       | DIGITAL.2.IN    | Channel 2 TTL input connection (common on pin 9)  |
| 7       | DIGITAL.3.IN    | Channel 3 TTL input connection (common on pin 9)  |
| 8       | DIGITAL.4.IN    | Channel 4 TTL input connection (common on pin 9)  |
| 9       | DIGITAL.RET     | Common connection for Digital Input Channels 1 - 4 (pins 5 - 8)   |
| 10      | +28V1.IN        | Power Supply connection for Output Channels 1 and 2 (common on pin 12). Required external 26 VDC (nominal) power supply.  |
| 11      | +28V2.IN        | Power Supply connection for Output Channels 3 and 4 (common on pin 12). Required external 26 VDC (nominal) power supply.  |
| 12      | 28V1&2.RET      | Common connection for both Output Channel Power Supply inputs (pins 10 and 11)  |
| 13      | VALVE1.OUT      | Channel 1 Output connection (return on pin 14)  |
| 14      | VALVE1.RET      | Return connection for Channel 1 Output (pin 13)   |
| 15      | VALVE2.OUT      | Channel 2 Output connection (return on pin 16)  |
| 16      | VALVE2.RET      | Return connection for Channel 2 Output (pin 15)   |
| 17      | VALVE3.OUT      | Channel 3 Output connection (return on pin 18)  |
| 18      | VALVE3.RET      | Return connection for Channel 3 Output (pin 17)   |
| 19      | VALVE4.OUT      | Channel 4 Output connection (return on pin 20)  |
| 20      | VALVE4.RET      | Return connection for Channel 4 Output (pin 19)   |

**Table 7-3. Series 90-30 Discrete I/O Modules**

| Catalog Number                                     | Points | Description   |
|--|--------|---|
| <b>Discrete Modules - Input</b>                    |        |   |
| IC693MDL230  | 8      | 120 VAC Isolated                                      |
| IC693MDL231  | 8      | 240 VAC Isolated                                      |
| IC693MDL240  | 16     | 120 VAC   |
| IC693MDL241  | 16     | 24 VAC  |
| IC693MDL630  | 8      | 24 VDC Positive Logic                                 |
| IC693MDL632  | 8      | 125 VDC Positive/Negative Logic                       |
| IC693MDL633  | 8      | 24 VDC Negative Logic                                 |
| IC693MDL634  | 8      | 24 VDC Positive/Negative                              |
| IC693MDL640  | 16     | 24 VDC Positive Logic                                 |
| IC693MDL641  | 16     | 24 VDC Negative Logic                                 |
| IC693MDL643  | 16     | 24 VDC Positive Logic, FAST                           |
| IC693MDL644  | 16     | 24 VDC Negative Logic, FAST                           |
| IC693MDL645  | 16     | 24 VDC Positive/Negative Logic                        |
| IC693MDL646  | 16     | 24 VDC Positive/Negative Logic FAST                   |
| IC693MDL652  | 32     | 24 VDC Positive/Negative Logic                        |
| IC693MDL653  | 32     | 24 VDC Positive/Negative Logic FAST                   |
| IC693MDL654  | 32     | 5/12 VDC (TTL) Positive/Negative Logic                |
| IC693MDL655  | 32     | 24 VDC Positive/Negative Logic                        |
| IC693ACC300  | 16     | Input Simulator                                       |
| <b>Discrete Modules - Output</b>                   |        |   |
| IC693MDL310  | 12     | 120 VAC, 0.5A   |
| IC693MDL330  | 8      | 120/240VAC, 2A  |
| IC693MDL340  | 16     | 120 VAC, 0.5A   |
| IC693MDL390  | 5      | 120/240VAC Isolated, 2A                               |
| IC693MDL730  | 8      | 12/24VDC Positive Logic, 2A                           |
| IC693MDL731  | 8      | 12/24VDC Negative Logic, 2A                           |
| IC693MDL732  | 8      | 12/24VDC Positive Logic, 0.5A                         |
| IC693MDL733  | 8      | 12/24VDC Negative Logic                               |
| IC693MDL734  | 6      | 125 VDC Positive/Negative Logic, 1A                   |
| IC693MDL740  | 16     | 12/24VDC Positive Logic, 0.5A                         |
| IC693MDL741  | 16     | 12/24VDC Negative Logic, 0.5A                         |
| IC693MDL742  | 16     | 12/24VDC Pos. Logic, Electronic Short Circuit Protect |
| IC693MDL750  | 32     | 12/24VDC Negative Logic                               |
| IC693MDL751  | 32     | 12/24VDC Positive Logic                               |
| IC693MDL752  | 32     | 5/24VDC (TTL) Negative Logic                          |
| IC693MDL753  | 32     | 12/24VDC Positive/Negative Logic, 0.5A                |
| IC693MDL930  | 8      | Relay, 4A Isolated                                    |
| IC693MDL940  | 16     | Relay, 2A   |
| IC693MDL931  | 8      | Relay, Isolated, N.C. and Form C, 8A                  |
| IC693DVM300  | 4      | Digital Valve Driver module, 1.6A, 24 VDC             |
| <b>Discrete Modules - Combination Input/Output</b> |        |   |
| IC693MAR590  | 8/8    | 120 VAC Input, Relay Output                           |
| IC693MDR390  | 8/8    | 24 VDC Input, Relay Output                            |

**Table 7-4. Series 90-30 Analog I/O Modules**

| Catalog Number        | Channels | Description                                     |
|-----------------------|----------|---|
| <b>Analog Modules</b> |          |   |
| IC693ALG220           | 4        | Analog Input, Voltage                           |
| IC693ALG221           | 4        | Analog Input, Current                           |
| IC693ALG222           | 16       | Analog Input, Voltage, High Density             |
| IC693ALG223           | 16       | Analog Input, Current, High Density             |
| IC693ALG390           | 2        | Analog Output, Voltage                          |
| IC693ALG391           | 2        | Analog Output, Current                          |
| IC693ALG392           | 8        | Analog Output, Current/Voltage, High Density    |
| IC693ALG442           | 4In/2Out | Analog Current/Voltage Combination Input/Output |

# Chapter 8

## Option Modules

[efesotomasyon.com](http://efesotomasyon.com)

---

---

This chapter provides an overview of Series 90-30 Option modules. For detailed information, the applicable user's manual should be consulted (these manuals are listed for each module at the end of its section).

### Third-Party Option Modules and the Accompany Program

In addition to the modules discussed in this chapter, numerous third-party option modules (and other hardware and software products) for the Series 90-30 PLC are available to meet a wide variety of needs. Third-party companies that meet GE Fanuc's standards may apply for recognition under the GE Fanuc Accompany Program. Details on the Accompany Program are found in the GE Fanuc Automation Solutions Catalog or on the GE Fanuc web site, both listed below. For information on third-party modules, consult the following:

- Your GE Fanuc PLC distributor or sales engineer
- The GE Fanuc web site at <http://www.gefanuc.com>
- The GE Fanuc *Automation Solutions Catalog*, GFW-0067

### Option Modules Discussed in this Chapter

- IC693CMM301 Genius Communications Module (GCM)
- IC693CMM302 Enhanced Genius Communications Module (GCM+)
- IC693BEM331 Genius Bus Controller (GBC)
- IC693BEM340 FIP Bus Controller (FBC)
- IC693BEM330 FIP Remote I/O Scanner
- IC693APU301/302 Motion Mate Axis Positioning Module (APM)
- IC693DSM302 Motion Mate Digital Servo Module (DSM302)
- IC693DSM314 Motion Mate Digital Servo Module (DSM314) – Preliminary
- IC693APU300 High Speed Counter (HSC) Module
- IC693BEM320 I/O Link Interface Module
- IC693BEM321 I/O Link Master Module
- IC693APU305I/O Processor Module
- IC693CMM321 Ethernet Interface Module
- IC693PCM300/301/31 Programmable Coprocessor Module (PCM)
- IC693CMM311 Communications Control Module (CCM)
- IC693ADC311 Alphanumeric Display Coprocessor (ADC) Module
- IC693TCM302 Temperature Control Module (TCM)
- IC693PTM100 Power Transducer Module (PTM) –Preliminary

## IC693CMM301 Genius Communications Module (GCM)

The *Genius Communications Module (IC693CMM301)* for the Series 90-30 PLC provides global communications on a Genius Communications bus between Series 90-30 PLCs and/or other GE Fanuc PLCs. Series 90-70, Series Six, and Series Five PLCs can communicate on this bus through their respective Genius Bus Controllers.

The Genius Communications bus is a token passing peer-to-peer, noise immune network optimized to provide high speed transfer of real time control data. Up to eight Series 90-30 PLC CPUs, in any combination, can communicate with each other over a single Genius I/O serial bus using a standard twisted pair, shielded cable.

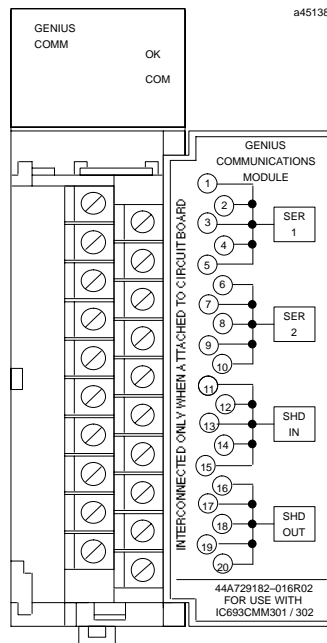

Figure 8-1. The IC693CMM301 GCM Module

### Status LEDs

The LEDs on the front of the GCM module indicate its operating status and should be on during normal operation.

- OK** Shows the status of the GCM module. This LED turns on after power up diagnostics are completed.
- COM** Shows the status of the Genius communications bus. This LED is on steadily when the bus is operating properly. It blinks for intermittent bus errors and is off for a failed bus. It is also off when no configuration has been received from the PLC CPU.

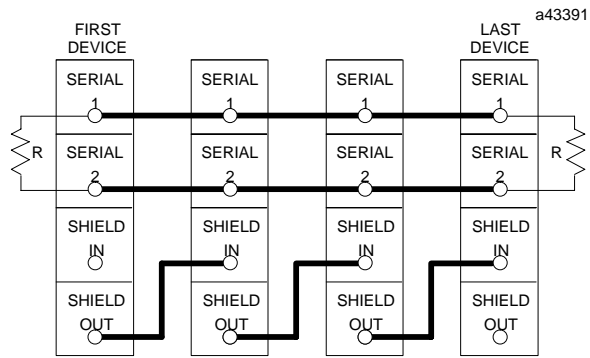

Figure 8-2. Genius Bus Wiring Schematic

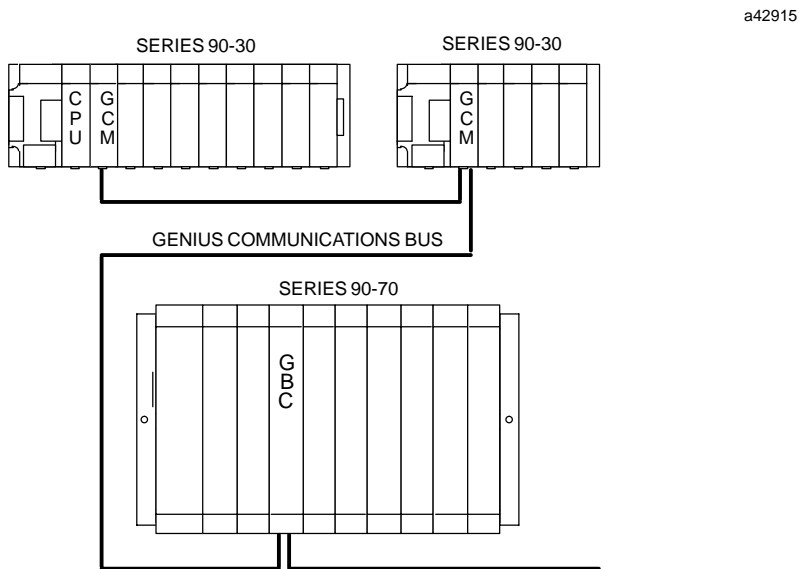

Figure 8-3. Example of Genius Communications Network

### GCM Documentation

For detailed information on the Genius Communications Module, including installation instructions, refer to GFK-0412, the *Series 90-30 Genius Communications Module User's Manual*.

## IC693CMM302 Enhanced Genius Communications Module (GCM+)

The *Enhanced Genius Communications Module (GCM+)*, IC693CMM302, is an intelligent module that provides automatic global data communications between a Series 90-30 PLC and up to 31 other devices on a Genius bus.

The GCM+ can be located in any standard Series 90-30 CPU baseplate, expansion baseplate, or remote baseplate. However, for most efficient operation, it is recommended that the module be installed in the CPU baseplate since the sweep impact time of the GCM+ module depends on the model of PLC and the baseplate where it is located. **Note: if a GCM module is present in a system, GCM+ modules cannot be included in the system.**

Multiple GCM+ modules can be installed in a Series 90-30 PLC system with each GCM+ having its own Genius bus serving up to 31 additional devices on the bus. For example, this allows a Series 90-30 PLC with three GCM+ modules to exchange global data with as many as 93 other Genius devices automatically. In addition to basic global data exchange, the GCM+ module can be used for various applications such as:

- Data monitoring by a personal computer or an industrial computer.
- Monitoring data from Genius I/O blocks (although it cannot control Genius I/O blocks).
- Peer-to-peer communications among devices on the bus.
- Master-slave communications among devices on the bus (emulates remote I/O).

The Genius bus connects to the terminal board on front of the GCM+ module.

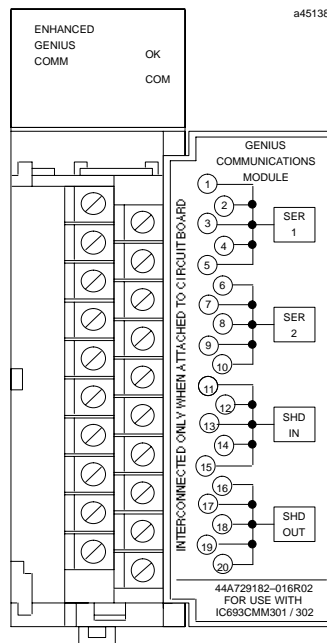

Figure 8-4. Enhanced Genius Communications Module

---

## Status LEDs

The LEDs on the front of the GBC indicate its operating status and should be on during normal operation.

- OK** Shows the status of the GBC module. This LED turns on after power up diagnostics are completed.
- COM** Shows the status of the Genius communications bus. This LED is on steadily when the bus is operating properly. It blinks for intermittent bus errors and is off for a failed bus. It is also off when no configuration has been received from the PLC CPU.

## GCM+ Documentation

For more information about the GCM+, refer to GFK-0695, *Series 90-30 Enhanced Genius Communications Module User's Guide*.

## IC693BEM331 Genius Bus Controller (GBC)

The Series 90-30 Genius Bus Controller (GBC), catalog number IC693BEM331, provides the interface between a Series 90-30 PLC and a Genius I/O serial bus. The GBC receives and transmits control data of up to 128 bytes for up to 31 devices on the Genius I/O bus. A Genius Bus Controller can serve:

- **Genius blocks**, which provide an interface to a wide range of discrete, analog, and special-purpose field devices. **Note that the GCM and GCM+ modules, described earlier, cannot control Genius blocks.**
- **Remote Drops**, which consist of Series 90-70 I/O racks interfaced to the bus through Remote I/O Scanner modules. Each of these drops can have any mix of Series 90-70 discrete and analog I/O modules, providing up to 128 bytes of input data and 128 bytes of output data.
- **Field Control I/O Station**, which consists of a Bus Interface Unit (BIU) and up to eight additional Field Control modules. The BIU provides intelligent processing, I/O scanning, and feature configuration for the I/O station.
- **Genius Hand-Held Monitor (HHM)**, which is a portable device that can also be permanently mounted. The HHM provides a convenient operator interface for block setup, data monitoring, and diagnostics.
- **Multiple hosts**, for communications using datagrams and Global Data.

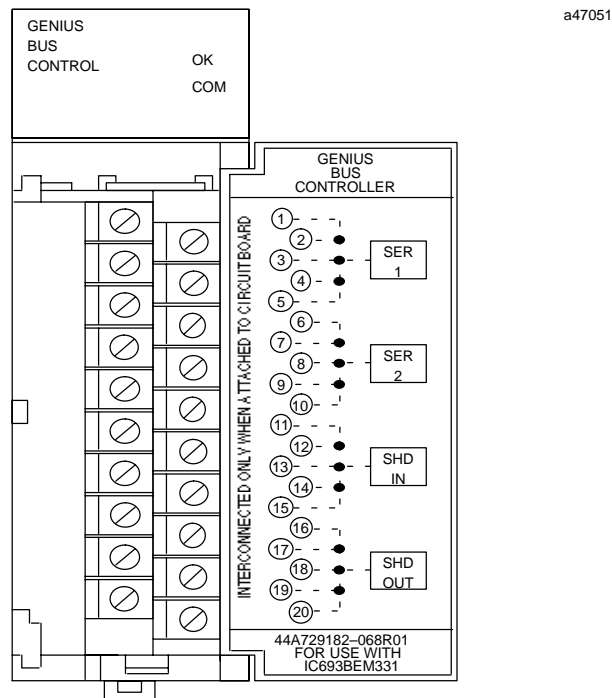

Figure 8-5. Genius Bus Controller Module

A bus may feature I/O control, enhanced by communications commands in the program. Or, a bus can be used entirely for I/O control, with many I/O devices and no additional communications. A bus can also be dedicated to CPU communications, with multiple CPUs and no I/O devices. More complex systems can also be developed, with dual CPUs and one or more additional CPUs for data monitoring.

## Number of Genius Bus Controllers

Up to eight Genius Bus Controllers or Enhanced Genius Communications Modules can be included in a Series 90-30 PLC system that has release 5.0 or later Logicmaster 90-30 software, and release 5.0 or later CPU firmware. A GBC *cannot* be installed in a system with a GCM.

The I/O devices on a bus may be Genius I/O blocks, or standard Series 90-70 I/O modules in one or more remote drops. The total number of I/O circuits that can be served by one Genius bus depends on the types of I/O devices that are used and the memory available in the CPU.

Many Genius I/O blocks have both inputs and outputs on the same block. Blocks configured in the Logicmaster 90-30 software as having both inputs and outputs will occupy the identical number of references in both %I and %Q memory, regardless of the block's software configuration. Unused references cannot be assigned to other inputs or outputs, *and should not be used in the application program*.

## Status LEDs

The LEDs on the front of the GBC indicate its operating status and should be on during normal operation.

- OK** Shows the status of the GBC module. This LED turns on after power up diagnostics are completed.
- COM** Shows the status of the Genius communications bus. This LED is on steadily when the bus is operating properly. It blinks for intermittent bus errors and is off for a failed bus. It is also off when no configuration has been received from the PLC CPU.

## Compatibility

Specific equipment or software versions required for compatibility with the GBC module are listed below.

### *Series 90-30 PLC*

**CPU:** The GBC module can be used with CPU models: IC693CPU311K, 321K, 331L or later, or any version of the IC693CPU313, 323, 340, 341, 350, 351, 352, 360, 363, and 364. The CPU firmware must be release 5.0 or later.

**Logicmaster 90-30 software:** rel. 5.0 (IC641SWP301L, 304J, 306F, 307F) or later is required.

### *Series Six PLC*

To exchange global data with a Genius Bus Controller, the Series Six Bus Controller must be catalog number IC660CBB902F/903F (firmware version 1.5), or later.

## Genius Hand-Held Monitor

The Genius Hand-Held Monitor can be used to display the GBC bus address, its software version, and the Series Six register address configured for global data. HHM version IC660HHM501H (revision 4.5) or later is required. There is no Hand-Held Monitor connector on the GBC module, but a Hand-Held Monitor can communicate with the GBC while connected to any other device on the bus. Optionally, an additional HHM mating connector can be installed on the bus near the GBC.

### Hand-Held Programmer

The GBC can be configured using a Series 90-30 Hand-Held Programmer (IC693PRG300).

### Genius I/O Blocks

Genius I/O blocks can be present on the same bus as the GBC. However, because the Bus Controller is *not* compatible with older *phase A* blocks, they should not be installed on the same bus.

### Genius Bus

The Genius bus is a shielded twisted-pair wire, daisy-chained between devices, and terminated at both ends. Proper cable selection is critical to successful operation of the system. Suitable cable types are listed in GEK-90486-1, the *Genius I/O System and Communications User's Manual*.

### Diagnostics

Genius blocks and other devices on the bus automatically report faults, alarms and certain other predefined conditions to the PLC.

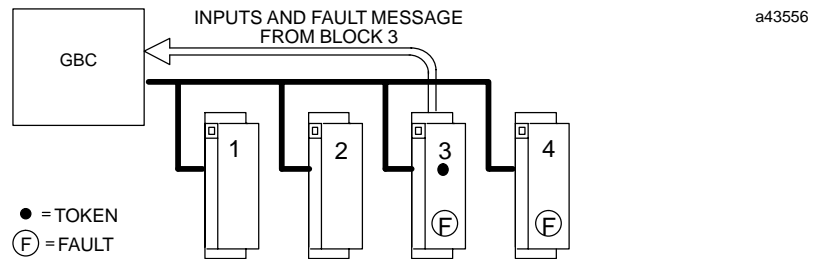

Only one diagnostic message can be sent during any bus scan. If a fault message has already been sent (by another device) during that scan, a device saves its own diagnostic message until the next available bus scan. For example, if the communications token is currently at device 3, and faults occur at devices 3 and 4 at the same time, device 3 can send its diagnostic message if another message has not already been sent. Device 4 must wait at least one more bus scan to send its diagnostic message.

The GBC stores any diagnostic messages it receives. They are read automatically by the Series 90-30 CPU. Faults can then be displayed in the fault table using the Logicmaster 90-30 software. A Genius Hand-held Monitor must be used to clear the faults from the fault table.

### Datagrams

The Series 90-30 GBC supports all Genius datagrams. Refer to chapter 3 of the *Genius I/O System and Communications User's Manual*, GEK-90486-1, for details on using datagrams.

### Global Data

Global Data is data that is automatically and repeatedly broadcast by a GBC. The Series 90-30 GBC can send up to 128 bytes of Global Data each bus scan. It can receive up to 128 bytes of Global Data each bus scan from each GBC on its bus.

## Sending Global Data

Once set up by configuration, Global Data is broadcast automatically. Other devices that receive the Global Data sent by a Series 90-30 PLC place it in these memory locations:

| Series 90-30 PLC Sends Global Data To: | Other CPU Places Global Data in these Memory Location:   |
|--|--|
| Series 90-30 PLC                       | %I, %Q, %G, %R, %AI, %AQ. Memory type and beginning address are chosen during configuration of the <i>receiving</i> GBC. |
| Series 90-30 GCM+                      | %I, %Q, %G, %R, %AI, %AQ   |
| Series 90-30 PLC/GCM                   | %G memory location corresponding to Device Number (16-23) of the Series 90-30 GBC that sent the data.                    |
| Series Six PLC                         | Register memory. Beginning Series Six address selected during configuration of the Series 90-30 GBC that sent the data.  |
| Series Five PLC                        | Register memory. Beginning Series Five address selected during configuration of the Series 90-30 GBC that sent the data. |
| Computer                               | PCIM or QBIM Input Table Segment corresponding to Device Number of the Series 90-30 GBC that sent the data.              |

## Receiving Global Data

The GBC can be configured to receive or ignore Global Data from any other GBC. The memory type and length for incoming Global Data are also selected during configuration. The Series 90-30 CPU can place incoming Global Data in %I, %Q, %G, %R, %AI, or %AQ memory.

### Genius Bus Controller Documentation:

See the following manuals for detailed information on the Series 90-30 Genius Bus Controller and the Genius I/O system:

- GFK-1034      *Series 90-30 Genius Bus Controller User's Manual*
- GEK-90486-1    *Genius I/O System and Communications User's Manual*
- GEK-90486-2    *Genius I/O Discrete and Analog Blocks User's Manual*
- GFK-0825      *Field Control Distributed I/O and Control System - Genius Bus Interface Unit User's Manual*
- GFK-0826      *Field Control Distributed I/O and Control System - I/O Modules User's Manual*

## IC693BEM340 FIP Bus Controller (FBC) Module

The Series 90-30 PLC FIP (Factory Instrumentation Protocol) Bus Controller (catalog number IC693BEM340) is used to interface a FIP I/O serial bus to a Series 90-30 PLC.

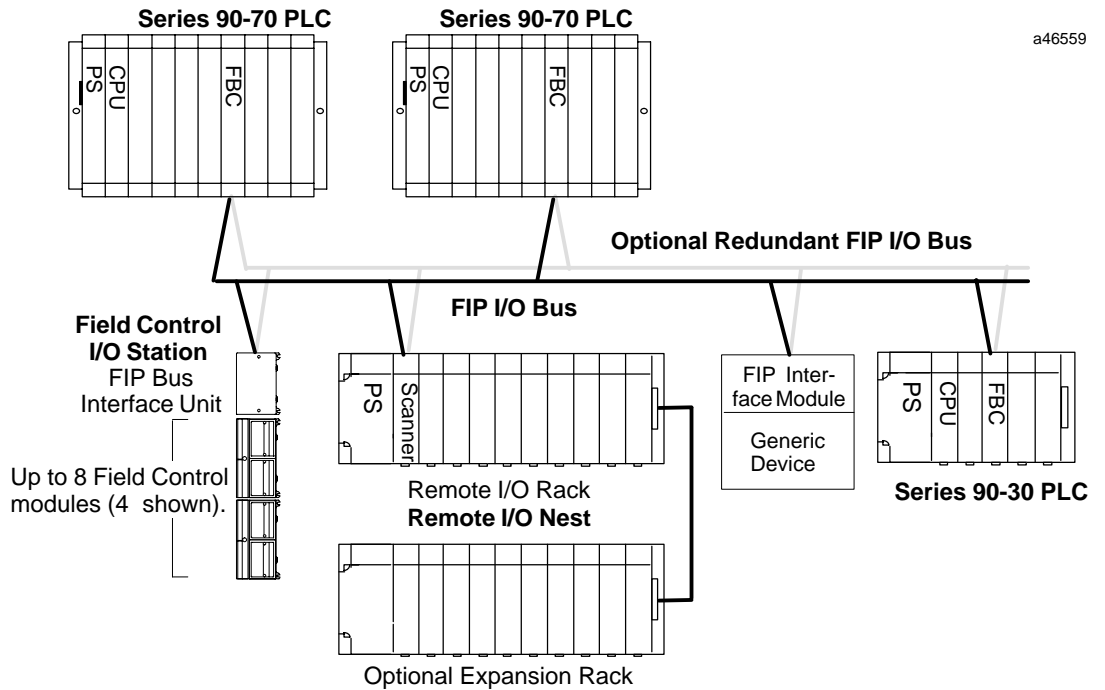

Figure 8-6. Example of FIP I/O System Configuration

A FIP bus is used primarily for I/O control. It also is used to store configuration data to remote devices and to report faults. Devices that can be on a FIP bus in a Series 90-30 PLC system include:

- **Series 90-70 PLC**, interfaced to a FIP bus by a Fip Bus Controller.
- **Field Control Stations**, Field Control I/O modules that are interfaced to the bus via a FIP Bus Interface Unit (BIU).
- **Remote Drops**, Series 90-30 I/O racks that are interfaced to the bus via FIP Remote I/O Scanner Modules. Each remote drop can include one 5- or 10-slot main rack, one 5- or 10-slot expansion rack and any mix of discrete and analog I/O modules.
- **Generic Devices**, such as general-purpose computers that are interfaced to the bus via a FIP Interface Module.

The FIP Bus Controller is a standard, rack-mounted Series 90-30 PLC module. It plugs easily into the PLC's backplane. The latch on the bottom of the module secures it in position.

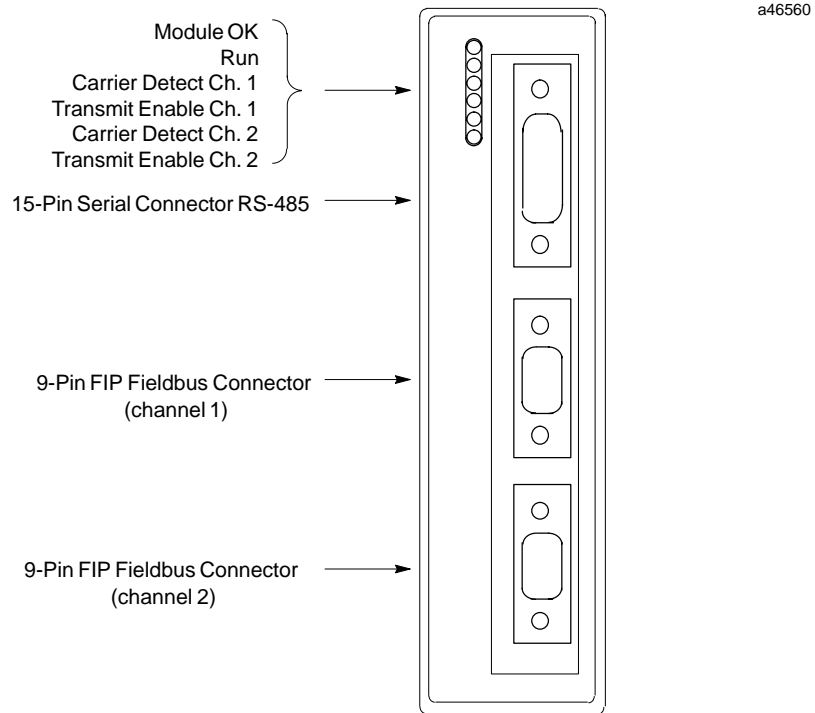

Figure 8-7. Series 90-30 FIP Bus Controller

There are no DIP switches or jumpers to set on the module.

The Series 90-30 FIP Bus Controller has six status LEDs, an RS-485 serial port, and two identical FIP bus connectors.

### Status LEDs

The 6 LEDs on the front of the FIP Bus Controller display module status and communications activity.

### Serial Port

The 15-pin serial port is used to connect a computer for upgrading the operating firmware of the Bus Controller and for configuring by an external configuration tool.

### FIP Bus Connectors

The two 9-pin connectors on the FIP Bus Controller provide for attachment of one or two FIP busses. The two busses provide a redundant bus capability.

## IC693BEM330 FIP Remote I/O Scanner Module

The FIP (Factory Instrumentation Protocol) Remote I/O Scanner (catalog number IC693BEM330) is an intelligent module that interfaces Series 90-30 I/O modules to a FIP bus. Up to 19 I/O modules can be accommodated by using two 10-slot baseplates connected by an expansion cable. Together, the Remote I/O Scanner and the modules it serves are referred to as an I/O Nest. The FIP Nest can include most Series 90-30 I/O modules.

The host CPU can be any type of CPU capable of communicating on a FIP bus. A module in the host (such as a FIP Bus Controller) provides the necessary interface between the FIP bus and the host CPU.

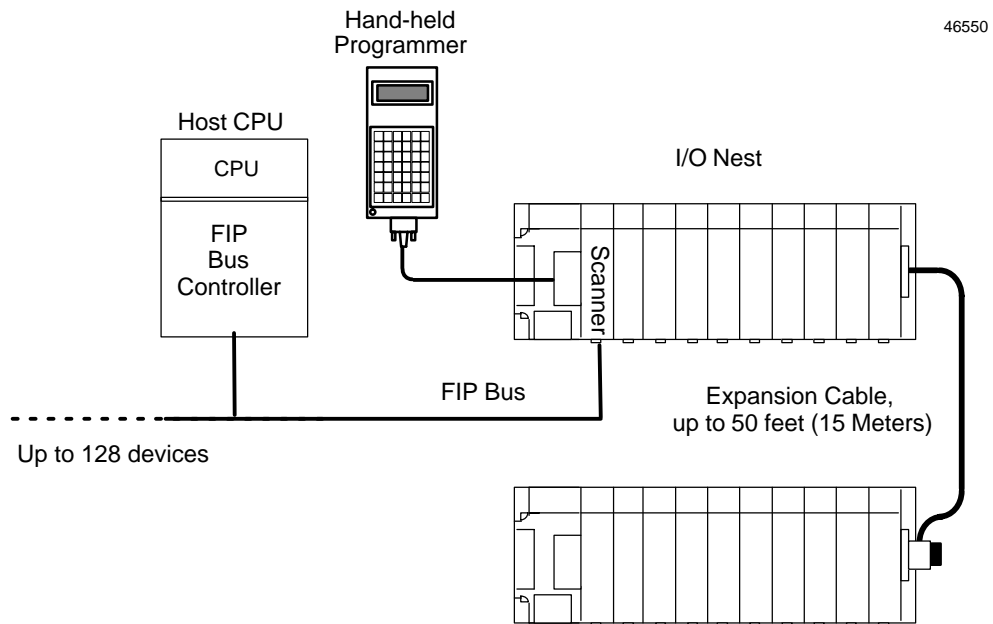

Figure 8-8. Example of FIP Remote I/O Scanner System Configuration

The Series 90-30 Hand-Held Programmer provides a convenient way to perform setup, monitoring, and control functions.

### Features of the Remote I/O Scanner

The FIP Remote I/O Scanner performs the following basic functions:

- controls operation of the I/O nest in the selected mode
- scans discrete and analog I/O modules and maintains I/O scan timing
- maps I/O data to FIP application variables
- detects module and system faults and reports them to the FIP network
- permits standalone configuration using Hand-Held Programmer
- retains its network configuration through loss of power
- permits I/O forcing from the Hand-Held Programmer
- detects and records input transitions

- supports FIP messaging services
- responds to an external synchronization signal
- can provide blinking or pulsed outputs
- can provide input filtering and chatter detection

### FIP Bus Interface

The Remote I/O Scanner communicates at a data rate of 1MHz. There are two versions of the FIP communications standard: FIP and WORLD FIP. A DIP switch on the module is used to select the version that will be used by the Remote I/O Scanner. (The same communications method will then be used on both bus cables).

The DIP switch on the module must be set to the FIP position for the Remote I/O Scanner to communicate with a Series 90-70 PLC.

### Module Description

The FIP Remote I/O Scanner is a standard Series 90-30 PLC module that plugs easily into the backplane of the baseplate.

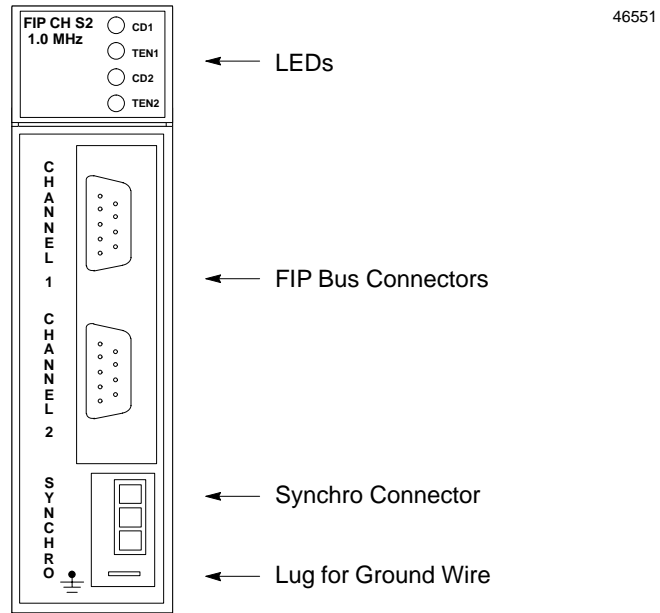

Figure 8-9. FIP Bus Interface Module

### Connectors

The front of the module has the following connectors:

- CHANNEL 1** 9-pin male D connectors for two FIP bus cables. A bus can be disconnected from the module without disturbing the continuity of the bus. The second bus is a backup for the first bus; its use is optional.
- CHANNEL 2**

- SYNCHRO** Connector for a FIP synchronization cable. It requires a mating connector such as Molex #39-01-4031. The synchronization capability is not used in a Series 90-70 PLC application.
- (ground)** The lug below the Synchro connector is used for the module ground wire (provided). The other end of the ground wire must be connected to the mounting bolt on the lower left corner of the baseplate and to chassis ground.

## LEDs

There are two pairs of LEDs at the top of the module. The upper pair is for channel 1 and the lower pair is for channel 2.

- CD1/CD2** the green Carrier Detected LEDs indicate the presence of a carrier-detect signal on their respective channels.
- TEN1/TEN2** the red Transmission Enabled LEDs indicate the module is generating transmissions on their respective channels.

## FIP Remote I/O Scanner Documentation:

- GFK-1037, *Series 90-30 FIP Remote I/O Scanner User's Manual*
- GFK-1038, *FIP Bus Controller User's Manual*

## IC693APU301/302 Motion Mate Axis Positioning Module (APM)

The Motion Mate APM is an easy-to-use intelligent, fully programmable 1-axis (IC693APU301) or 2-axis (IC693APU302) motion control module for the Series 90-30 PLC. The APM allows a PLC user to combine high-performance control with PLC logic solving functions in one integrated system. The APM can be configured to operate in either *Standard mode* or *Follower mode*. When used in Standard mode, it combines high-performance motion control with PLC logic solving functions in one integrated system. When used in Follower mode, it provides high-performance "electronic gearing" for continuous master/slave applications. The desired mode is easily selected by configuring a setup parameter in the LogiMaster 90-30 Configuration software.

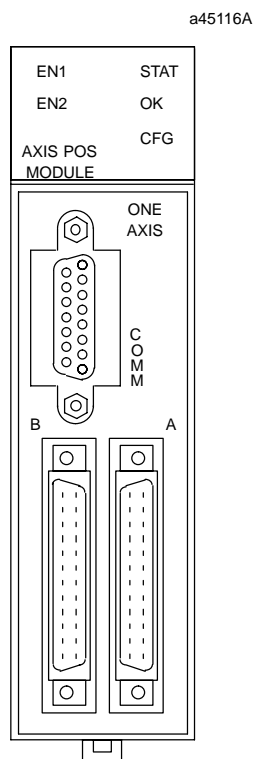

Figure 8-10. Motion Mate APM Module

The Series 90-30 and APM operate together as one integrated motion control package. The APM controls axis motion and handles all direct communications to the drive and machine while the PLC automatically transfers data between PLC tables and the APM.

The PLC also provides a means for connecting Operator Interfaces, which can control and monitor system operation. An example of an APM servo system showing the hardware and software used to configure, program, and operate the system is shown below. The APM can be installed in any Series 90-30 CPU, expansion, or remote baseplate. For embedded CPUs (311, 313, or 323), you may have up to three APM modules. For a modular CPU (331 or higher), you may have up to eight APM modules in one system with a maximum of three APM modules per baseplate. LogiMaster 90-30 or VersaPro software is used to configure the APM.

Multiple motion programs may be created and stored in the APM (maximum of 10 may be stored in the APM) with the Motion Programmer software package. Also, a single short

program can be created using the Program Zero Editor in the LogiMaster 90-30 software package.

The APM faceplate (front panel) has two 24-pin high-density connectors for servo connections. The connector labeled A contains connections for Axis 1. Connector B, for a 1-axis APM, contains general purpose connections. Connector B, for a 2-axis APM, has connections for Axis 2 as well general purpose connections. To make wiring easier to the drive and machine, each high-density connector is typically connected by a short cable to a terminal block.

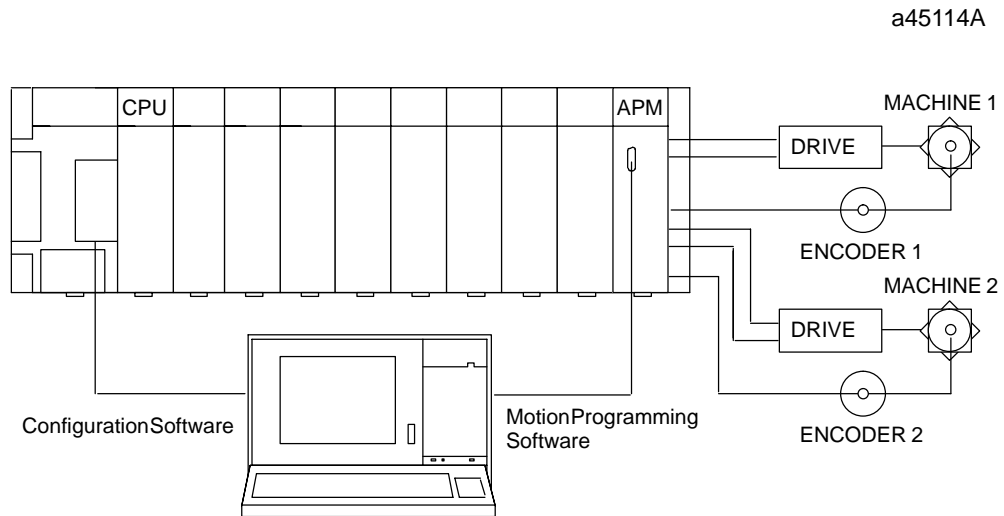

Figure 8-11. Example of Motion Mate APM Servo System

### APM Cables

These cables consists of a 24-pin I/O connector , a cable, and a 25-pin D-type terminal block connector. (Cables are documented in Chapter 10.) Available cables are:

- IC693CBL311 (10 feet/3 meters)
- IC693CBL319 (3 feet/1 meter)
- IC693CBL317 (10 feet/3 meters) with an 8” external shield pigtail
- C693CBL320 (3 feet/1 meter) with an 8” external shield pigtail

For building custom-length cables, the 24-pin I/O cable connector is available in three different kits (solder eyelet receptacle, crimp wire receptacle, and IDC (ribbon) receptacle). The terminal block is Weidmuller RD25 910648 or equivalent (must be compatible with the I/O cable IC693CBL311/319/317/320 – see Chapter 10 for details).

### Motion Mate APM Module Documentation

See the following manuals for detailed information on Power Mate APM Modules:

- GFK-0840 *Motion Mate APM for Series 90-30 PLC Standard Mode User’s Manual*
- GFK-0781 *Motion Mate APM for Series 90-30 PLC Follower Mode User’s Manual*
- GFK-0664 *Series 90 PLC APM Programmer’s Manual*

Related servo manual:

- GFK-1581 *SL Series Servo User’s Manual*

## IC693DSM302 Motion Mate Digital Servo Module (DSM302)

The Motion Mate DSM302 is a high-performance, 2-axis motion control module that is highly integrated with the logic solving and communications functions of the Series 90-30 PLC. In digital mode, this module controls GE Fanuc digital servos. Beginning with the release of Firmware 1.40, this module was provided with the capability of controlling servos with an analog command input, such as the GE Fanuc SL Series Servos, or third party analog servos.

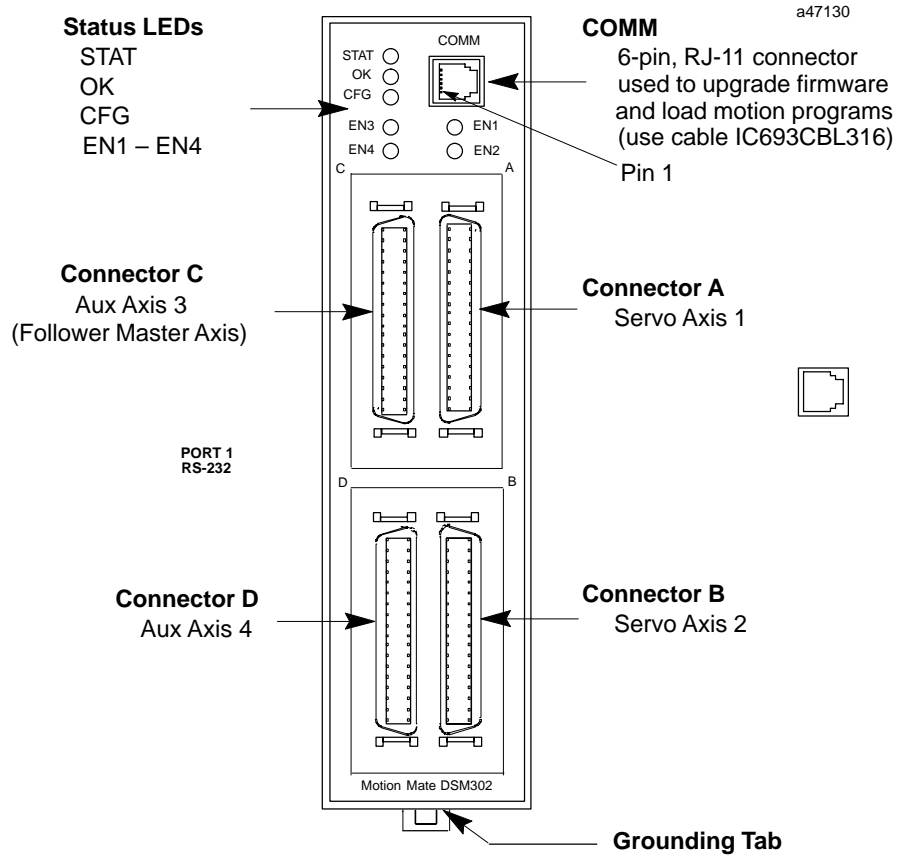

Figure 8-12. Motion Mate DSM302 Module

## Features.

- Digital Signal Processor (DSP) control of GE Fanuc Servos
- Block Processing time under 5 milliseconds
- Velocity Feed forward and Position Error Integrator to enhance tracking accuracy
- High resolution of programming units
  - Position: -8,388,608...+8,388,607 User Units
  - Velocity: 1 ... 8,388,607 User Units/sec
  - Acceleration: 1 .. 134,217,727 User Units/sec/sec
- Simple and powerful Motion Program instruction set
- Simple 1- or 2-axis motion programs with synchronized block start
- Program support for a short motion program, called Program 0, which can be created in Logicmaster 90-30/20/Micro configuration software
- Non-volatile storage for 10 programs and 40 subroutines, created with the APM Motion Programming software.
- User scaling of programming units (User Units)
- DSM firmware, stored in Flash memory, is updated via its front panel COMM port.
- Generic programming using command parameters as operands for Acceleration, Velocity, Move, and Dwell Commands
- Configured with Logicmaster 90-30/20/Micro software (version 8.02 or later)
- Automatic Data Transfer between PLC tables and DSM302 without user programming
- Ease of I/O connection with factory cables and terminal blocks as well as a serial port for connecting programming devices. The serial port also allows "soft" upgrades to firmware, which is stored in Flash memory.
- Control of GE Fanuc Digital servos, analog SL Series Servos, or third party analog servos.
- Home and overtravel switch inputs for each Servo Axis
- Two Position Capture Strobe Inputs for each Position Feedback Input
- 5v , 24v and analog I/O for use by PLC
- A Quad B Encoder input for Follower Master axis
- 13 bit Analog Output can be controlled by PLC or used as Servo Tuning monitor

## Configuration

The DSM302 is configured using Logicmaster 90-30 or VersaPro software . The DSM302 is assigned to a particular slot and rack like any other PLC module. In addition, other types of configuration data must be entered such as:

- I/O addresses where the CPU to DSM302 data transfers take place
- Serial Port Setup (COMM on module's front panel) for connecting the APM Motion Programmer
- DSM302 Setup Data
- A small optional motion program, Program Zero (20 lines in standard mode, 9 lines in follower mode)

## Modes of Operation

### Standard Mode

In *Standard* mode, the module provides closed loop position and velocity control for one or two servo motors. User Programming units can be adjusted by configuring a User Units to Feedback Counts ratio. *Jog*, *Move at Velocity* and *Execute Motion Program* commands allow Standard mode to be used in a wide variety of positioning applications.

### Follower Mode

In *Follower* mode, the module provides most of the same features as Standard mode with a major exception that the User Units to Counts ratio is not configurable. This ratio is fixed at 1:1 in Follower mode. In Follower mode, a Master Axis position input can be enabled. Each Follower axis tracks the Master Axis input at a programmable A:B ratio. Motion caused by *Jog*, *Move at Velocity* and *Execute Motion Program* commands can be combined with follower motion generated by the master axis. Follower options include:

- Selection of internal or external Master Axis sources
- Acceleration Ramp to smoothly accelerate a slave axis until its position and velocity lock to the master/slave A:B ratio
- Winder mode ("electronic fishing reel") for coil winding and material handling applications

### IC693DSM302 Documentation

- GFK-1464, *Motion Mate DSM302 for Series 90-30PLCs User's Manual*.
- GFK-0664, *Series 90-30 PLC APM Programmer's Manual*

Related servo manuals:

- GFK-1581, *SL Series Servo User's Manual*
- GFH-001, *Beta Series Servo Products Specification Guide*
- GFZ-65192EN, *Alpha Series Servo Amplifier (SVU) Descriptions Manual*
- GFZ-65162E, *Control Motor Amplifier, Alpha Series*
- GFZ-65142E, GFZ-65150E, GFZ-65165E, *Alpha Series Servo Motor Manuals*

# IC693DSM314 Motion Mate Digital Servo Module (DSM314)- Preliminary

## Note

**This information was preliminary at the time of writing and could change by the time this module is released. The module is expected to be available in late 1999. Please contact your distributor for up-to-date information.**

The Motion Mate DSM314 is a high-performance motion control module that is highly integrated with the logic solving and communications functions of the Series 90-30 PLC. In digital mode, this module controls GE Fanuc digital servos. In analog mode, this module controls servos with an analog command input, such as the GE Fanuc SL Series Servos, or third party analog servos.

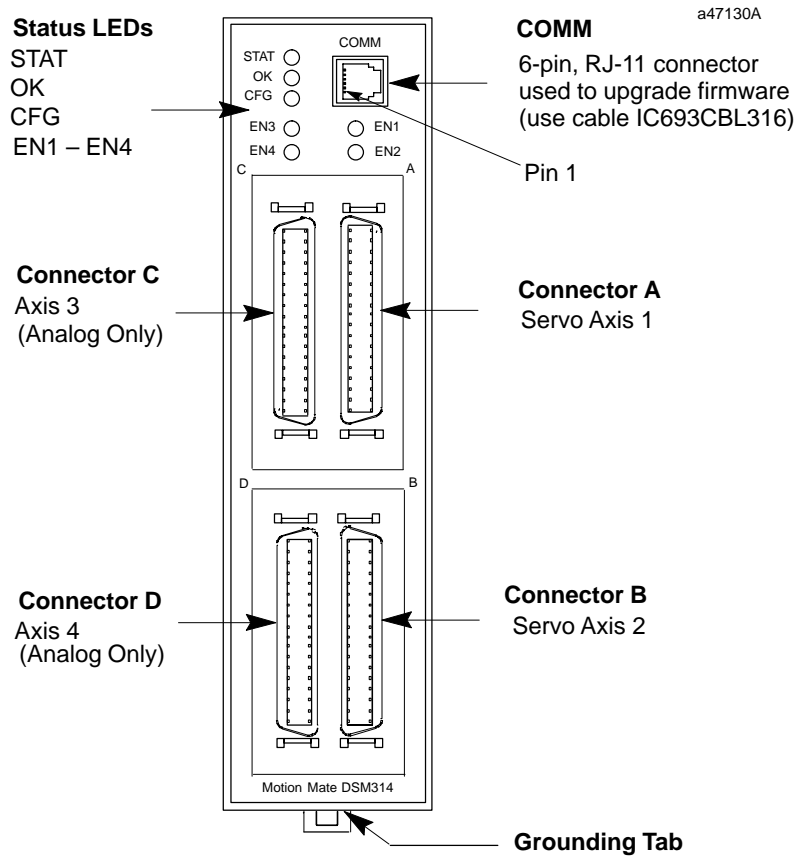

Figure 8-13. Motion Mate DSM314 Module

## Features.

- Digital Signal Processor (DSP) control of GE Fanuc Servos
- Block Processing time under 5 milliseconds
- Position Loop Velocity Feed forward, Acceleration Feed Forward, and Position Error Integrator to enhance tracking accuracy
- High resolution of programming units
  - Position: -536,870,911...+536,870,911 User Units or Counts, whichever is greater.
  - Velocity: 1 ... 8,388,607 User Units/sec
  - Acceleration: 1 .. 1,073,741,823 User Units/sec/sec
- Simple yet powerful motion program instruction set
- Single or multi-axis motion programs with synchronized block start
- Configured and programmed with VersaPro software (Version 1.1 or later).
- Compatible with Series 90-30 CPUs equipped with Firmware Release 10.0 or later.
- Single point of connect for all programming and configuration tasks, including motion program creation (Motion Programs 1 - 10) and Local Logic programming. All programming and configuration is loaded through the PLC's programming communications port. In turn, the CPU loads all configuration, motion programs, and Local Logic programming to the DSM314 across the PLC backplane.
- Each motion file supports up to 10 programs and 40 subroutines. These are created with VersaPro software (Version 1.1 or later) and loaded to the DSM314 over the PLC backplane.
- Local Logic programming with VersaPro software (Version 1.1 or later). Local Logic lets the user create a logic program internal to the DSM314 that runs in synchronization with the motion program and is independent of the PLC scan. This gives the DSM314 the ability to respond quickly to motion-related I/O requirements.
- User scaling of programming units (User Units) including Follower Mode.
- DSM314 firmware, stored in Flash memory, will be updated via its front panel COMM port. Firmware update kits will provide firmware and Loader software on floppy disk. Firmware will also be available for download on the GE Fanuc web site.
- Generic programming using command parameters as operands for Acceleration, Velocity, Move, and Dwell Commands
- Automatic Data Transfer between PLC tables and DSM314 without user programming
- Ease of I/O connection with factory cables and terminal blocks.
- Control of GE Fanuc Digital servos, SL Series Servos, or third party analog servos.
- Home and overtravel switch inputs for each Servo Axis
- Two Position Capture Strobe Inputs for each axis can capture axis and/or master position in less than 20 microseconds.
- 5vdc (4 points) , 24vdc (4 points) and analog I/O for use by PLC. Digital I/O can be used by onboard Local Logic processor.
- Quadrature Encoder input for Follower Master axis
- 13 bit Analog Output can be controlled by PLC or used as Servo Tuning monitor

## Key Differences Between the DSM302 and DSM314

| Feature                                      | DSM302   | DSM314   |
|--|--|--|
| Max. No. of Servo Axes                       | 2  | 2 digital, 4 analog  |
| Motion Programming for Motion Programs 1–10. | Uses DOS-based APM Motion Programmer                       | Uses VersaPro's (Version 1.1 or later) Motion Editor   |
| Program Zero                                 | Supported  | Not supported  |
| Motion Program Loading                       | Through COMM port on module's faceplate                    | Across CPU backplane   |
| Motion Program Storage                       | DSM memory   | PLC CPU memory   |
| Configuration                                | Logicmaster or VersaPro 1.1 or later                       | VersaPro 1.1 or later  |
| Local Logic feature                          | Not supported  | Supported. Local Logic programs are created in VersaPro's (Version 1.1 or later) Local Logic Editor. |
| Camming                                      | Not supported  | Support planned for future release (first half of year 2000)   |
| Follower Modes                               | Normal, Ramp, Winder                                       | Ramp only  |
| Position Capture                             | 250 microseconds   | < 20 microseconds  |
| User Units to Counts Ratio                   | Not configurable in Follower Mode                          | Configurable in Follower Mode  |
| Maximum Position Units                       | 8,388,608 User Units                                       | 500,000,000 User Units or Counts, whichever is greater.  |
| Supported CPUs                               | All Series 90-30 CPUs with Firmware Release 6.50 or later. | CPUs 350, 352, 360, 363, 364 with Firmware Release 10.0 or later.                                    |
| Number of %I bits                            | 64 (fixed)   | 32/48/64/80 (configurable)   |
| Number of %Q bits                            | 64 (fixed)   | 32/48/64/80 (configurable)   |
| Number of %AI words                          | 40/50/64 (configurable)                                    | 24/44/64/84 (configurable)   |
| Number of %AQ words                          | 6/9/12 (configurable)                                      | 3/6/9/12 (configurable)  |

### Configuration

The DSM314 is configured using VersaPro software, Version 1.1 or later. The DSM314 is assigned to a particular slot and rack like any other PLC module. In addition, other types of configuration data must be entered such as:

- I/O addresses where the CPU to DSM314 data transfers take place.
- Serial Port Setup for connecting a Personal Computer if a firmware update is needed.
- DSM314 configuration data such as motor type, feedback type, mode, gains, etc.
- Up to 10 motion programs and 40 subroutines using the VersaPro Motion Editor.
- Local Logic programs using the VersaPro Local Logic (LL) Editor.

## Operation Modes

The maximum digital axis count is two. The maximum analog axis count is four. In determining the number of axes available in analog modes, keep in mind that use of a Master Encoder input or of a Local Logic program each reduce the maximum axis count by one.

### Standard Mode

In *Standard* mode, the module provides closed loop position and velocity control for these maximum axis configurations:

- Two digital axes (Local Logic program may be used).
- Four analog axes if Local Logic program is not used.
- Three analog axes if Local Logic program is used.

User Programming units can be adjusted by configuring a User Units to Feedback Counts ratio. *Jog*, *Move at Velocity* and *Execute Motion Program* commands allow the DSM314 to be used in a wide variety of positioning applications.

### Follower Mode

In *Follower* mode, the module provides most of the same features as Standard mode. In Follower mode, a Master Axis position input can be enabled. Each Follower axis tracks the Master Axis input at a programmable A:B ratio. Motion caused by *Jog*, *Move at Velocity* and *Execute Motion Program* commands can be combined (superimposed) with follower motion generated by the master axis. Follower options include:

- Selection of internal or external Master Axis sources
- Acceleration Ramp to smoothly accelerate a slave axis until its position and velocity lock to the master/slave A:B ratio

The maximum axis configurations in *Follower* mode are:

- Two digital axes. May have Master Encoder input and a Local Logic program.
- Three analog axes with a Master Encoder input but no Local Logic program.
- Two analog axes with a Master Encoder input and Local Logic program.

### IC693DSM314 Documentation

- GFK-1742, *Motion Mate DSM314 for Series 90-30 PLC User's Manual (will not be available until late 1999)*.

Related servo manuals:

- GFK-1581, *SL Series Servo User's Manual*
- GFH-001, *Beta Series Servo Products Specification Guide*
- GFZ-65192EN, *Alpha Series Servo Amplifier (SVU) Descriptions Manual*
- GFZ-65162E, *Control Motor Amplifier, Alpha Series*
- GFZ-65142E, GFZ-65150E, GFZ-65165E, *Alpha Series Servo Motor Manuals*

## IC693APU300 High Speed Counter (HSC) Module

The High Speed Counter (IC693APU300) for the Series 90-30 PLC is a single-slot module which can be used in applications where pulse input rates exceed the input capability of the PLC or where too large a percentage of PLC processing capability would be required. The High Speed Counter provides direct processing of rapid pulse signals up to 80 KHz for industrial applications such as: meter proving, turbine flowmeter, velocity measurement, material handling, motion control and process control.

With direct processing, the High Speed Counter module is able to sense inputs, count, and respond with outputs without needing to communicate with a CPU. It can be configured to count either up or down, to count both up and down, or to count the difference between two changing values. The module can be configured to provide 1, 2, or 4 counters of differing complexity.

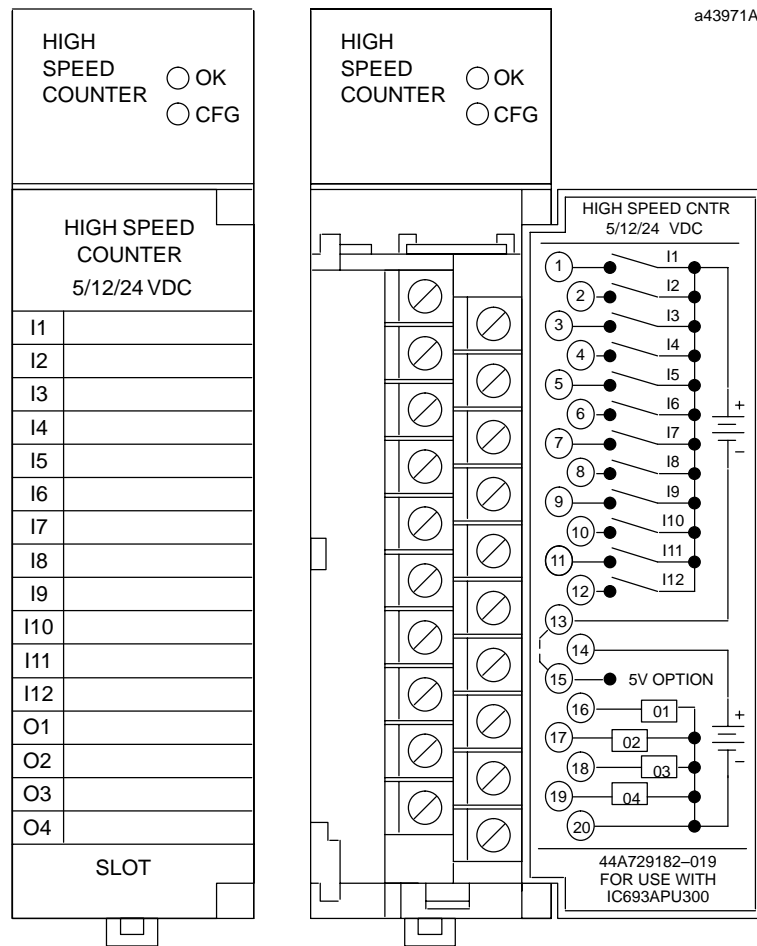

Figure 8-14. High Speed Counter (HSC)

The High Speed Counter can be installed in any Series 90-30 baseplate and is configured using either the Hand-Held Programmer, Logicmaster 90-30/20 or VersaPro software. Many features can also be configured from the user's application program. There are no jumpers to be set on the module. Two LEDs at the top of the module indicate the operating status of the module and the status of configuration parameters.

### High Speed Counter Documentation

Details can be found in GFK-0293, *Series 90-30 High Speed Counter User's Manual*.

## IC693BEM320 I/O LINK Interface (Slave) Module

The I/O LINK Interface module (IC693BEM320) provides an interface between a Series 90-30 PLC and a proprietary Fanuc I/O LINK in a Fanuc CNC (Computer Numerical Control), or a Series 90-70 PLC. This module is configured as a slave device only (see the IC693BEM321 for master applications). The Fanuc I/O LINK is a serial interface which provides high speed exchange of data between a master and up to 16 slaves. An example of a Series 90-30 PLC in a Fanuc I/O LINK system configuration is shown in the following illustration.

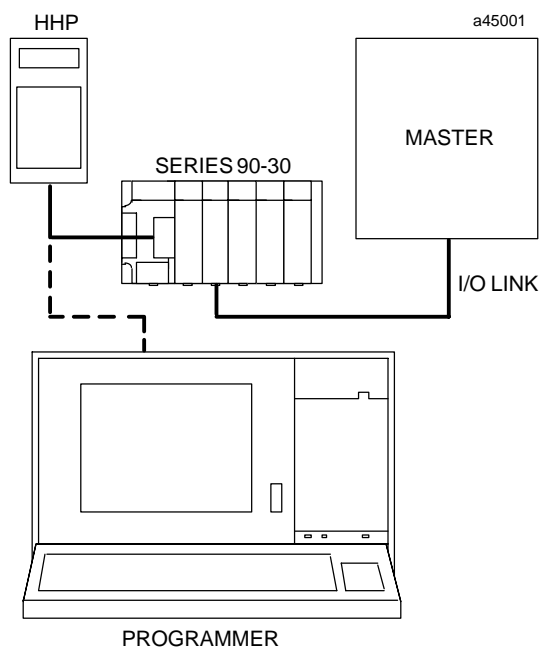

Figure 8-15. Example of a Series 90-30 PLC in a Fanuc I/O LINK Configuration

The Series 90-30 I/O LINK Interface module is configured as a slave device only and allows the Series 90-30 PLC to send either 32 or 64 I/O points to the I/O LINK. The I/O LINK module must be configured as either a 32 or 64 point I/O module during installation by setting a jumper plug inside of the front cover of the module to either 32 I/O or 64 I/O.

An I/O LINK Interface module can be installed in any model of Series 90-30 PLC, and any number of I/O LINK Interface modules can be installed in a system within the current limits of the baseplate and other I/O modules installed in the baseplate. For more details, see "Load Requirements for Hardware Components" in Chapter 12 of this manual.

### I/O Link Interface Documentation

For detailed information on this module, refer to GFK-0631, the *Series 90-30 I/O LINK Interface Module User's Manual*.

## IC693BEM321 I/O LINK Master Module

The Series 90-30 I/O LINK Master Module (IC693BEM321) allows a Series 90-30 PLC to act as a master on a proprietary Fanuc I/O LINK. The Fanuc I/O LINK is a serial interface which provides high-speed exchange of I/O data between the master and up to 16 slaves. The master can receive 1024 discrete inputs from slaves, and send up to 1024 discrete outputs.

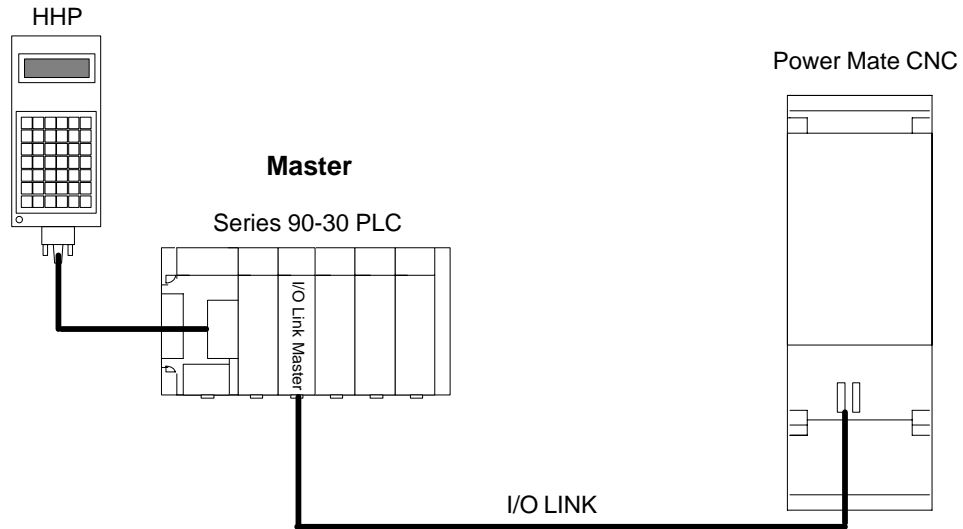

**Figure 8-16. Example of I/O LINK Master System Configuration**

The illustration above shows a simple I/O LINK system: a Series 90-30 PLC used as a master, a Series 90-30 Hand-held Programmer, an I/O LINK, and one slave. In the illustration, the slave is a Power Mate CNC. Other devices that can be used as slaves include the Series 90-70 PLC, the Series 90-30 PLC, the Fanuc Series 0 CNC, Fanuc Connection Units, and Fanuc Operator Panels.

The module can be configured using the Logicmaster 90 (LM90) configuration software release 4.5 (or later), VersaPro software, Control software release 2.0 or later, or a Series 90-30 Hand-held Programmer (HHP).

Any number of I/O LINK Master Modules can be installed in a Series 90-30 PLC. When there are multiple I/O LINK Master Modules in the same PLC, they must be on separate I/O LINKs. An I/O LINK Master Module can be installed in any I/O slot in any baseplate. The maximum number of I/O LINK Master Modules that can be installed in the CPU baseplate is six,

### Restart Pushbutton

The LINK RESTART pushbutton provides a convenient means of restart if a failure occurs. Pushing the Restart pushbutton restarts the operation of the LINK.

### Serial Port

The front of the module has one 20-pin, Honda-type connector, used for connection to the first slave on the I/O LINK. Signal levels are RS422/485 compatible.

### Compatibility

The Series 90-30 I/O LINK Master Module is compatible with the following devices:

- **Host CPU**
  - Series 90-30 CPU models 311, 313, 321, 323, 331, and 341 release 4.4 or later, and all versions of the CPU models 350, 351, 352, 360, 363, and 364.
  - Series 90-30 Hand-held Programmer (HHP)
- **Programmer**
  - Hand-Held Programmer
  - Logicmaster™ 90-30 Programming Software Configurator, release 4.5 or later.
  - VersaPro Software.
  - Control programming software, Version 2.0 or later.
- **Slave Units**
  - Power Mate models A, C, D, and E
  - Series 0 CNC
  - Fanuc Operator Panel Unit
  - Fanuc Connection Unit 1
  - Fanuc Connection Unit 2
  - Series 90-30 PLC with 90-30 I/O LINK Slave Module
  - Series 90-70 PLCs with 90-70 I/O LINK Interface Module set up as slave

### I/O Link Master Module Documentation

For detailed information on this module, refer to GFK-0823, the *Series 90-30 I/O LINK Master Module User's Manual*,

## IC693APU305 I/O Processor Module

The I/O Processor (IOP) module (IC693APU305) for the Series 90-30 PLC provides direct processing of rapid pulse signals for industrial control applications such as:

- Fast response process control
- Velocity measurement
- Material handling, marking, and packaging

Direct processing means that the module is able to sense inputs, process the input information, and control the outputs without needing to communicate with a CPU.

During each CPU sweep, the I/O Processor communicates with the CPU through 32 discrete inputs (%I), 15 words of analog inputs (%AI), 32 discrete outputs (%Q), and 6 words of analog outputs (%AQ). The %AQ outputs can be used by the CPU program to set up timer values or send other controlling parameters to the I/O Processor.

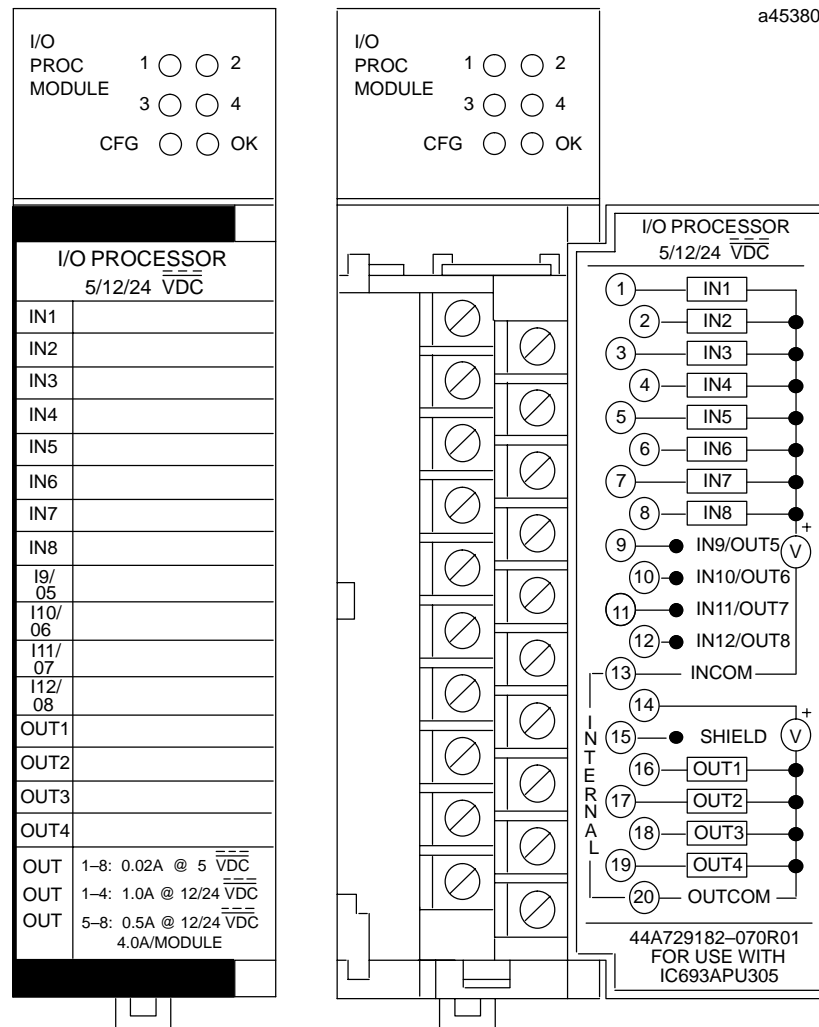

Figure 8-17. I/O Processor Module

The I/O Processor is configured using the Series 90-30 Hand-held Programmer, Logicmaster 90-30, or VersaPro software. Many configuration parameters can be

modified from the user's application program as well. Each configuration parameter is set to a factory default value which is suitable for many applications. There are no jumpers or DIP switches to set on the module. Six green LEDs at the top of the module indicate the operating status of the module, the status of configuration parameters, and the state of hardware outputs 1 through 4.

## Module Features

Module features include:

- Up to 12 positive logic (source) inputs with input voltage range selection of either 5 VDC (TTL) or 10 to 30 VDC (non-TTL).
- Up to eight positive logic (source) outputs: four outputs with 1 amp rating and four configurable outputs with 0.5 amp rating
- Outputs protected by replaceable fuse (one fuse common to all outputs)
- Dedicated processor provides 500  $\mu$ s I/O update
- Counts per Timebase register for input rate measurement
- Total Counts register (32-bit) accumulates total counts received by module
- Four Strobe data registers for input position capture
- Two Timer data registers for indicating input pulse length or input spacing in milliseconds
- Thirty-two range comparators (outputs returned in %I and %AI data)
- Software configuration
- Internal module diagnostics
- Individual LEDs that indicate Module OK and Configured OK status
- Individual LEDs that indicate state of Outputs 1 through 4
- A removable terminal board for connection of field wiring.

Inputs can be used as count signals or edge-sensitive strobe signals. Outputs can be used to drive indicating lights, solenoids, relays, and other devices.

Power to operate the module's logic circuitry is obtained from the 5 VDC bus on the baseplate backplane. Power sources for the input and output devices must be supplied by the user or by the +24 VDC isolated output of the Series 90-30 power supply. The I/O Processor module provides a selectable threshold voltage to allow the inputs to respond to either a 5 VDC signal level or a 10 to 30 VDC signal level. The threshold is selected by configuration.

All configuration parameters for the module are downloaded from the PLC to the I/O Processor after it passes its internal diagnostics. Once the module has been successfully configured, the CONFIG OK LED will turn on. Configuration parameters can be changed using Logicmaster 90-30 programming software configuration software or the Hand-Held Programmer.

Operation of the I/O Processor module is monitored by a watchdog timer circuit. If the watchdog timer detects a module failure, it will force all outputs off and turn off the MODULE OK LED.

## I/O Processor Module Documentation

Please refer to publication GFK-1028, *Series 90-30 I/O Processor User's Manual*.

## IC693CMM321 Ethernet Interface Module

The Ethernet Interface module (IC693CMM321) provides an interface that allows you to attach the Series 90-30 PLC to an Ethernet LAN via an external transceiver and AAUI cable, and to communicate with hosts and other control devices on the network.

The Ethernet Interface for the Series 90-30 PLC has *client/server* capability. As a *client* it can initiate communications with other PLCs containing Ethernet Interfaces. This is done from the ladder program using the COMMREQ Function Block. As a *server* it responds only to requests from other devices such as a Host computer running a Host Communications Toolkit application or another Series 90-30 PLC acting as a *client*.

The Ethernet Interface allows you to:

- Directly attach your PLC to an Ethernet network
- Initiate transfer of data to the PLC from another device
- Communicate simultaneously to multiple devices with up to 16 server connections
- Interface with other GE Fanuc devices, as well as with devices from other vendors
- Communicate from a Host computer (or other control device)
- Diagnose and maintain your system using diagnostic and station management tools

The Ethernet Interface *does not* support the Series 90-30/20/Micro Hand-Held Programmer. Either one or two Ethernet Interface modules can be installed in any Series 90-30 baseplate.

The Ethernet Interface connects to an Ethernet network through an external SQE enabled transceiver (GE Fanuc catalog no. IC649AEA102 or IC649AEA103 or equivalent. See Appendix L). The following figure shows the layout of the Ethernet Interface.

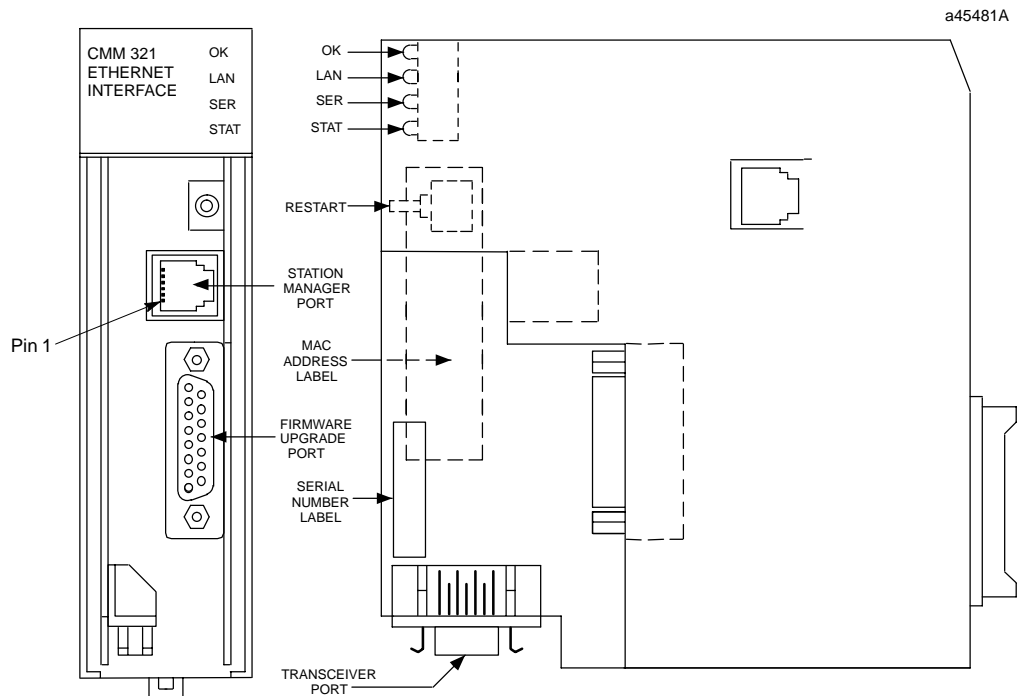

Figure 8-18. Ethernet Interface Module

Four LEDs are located at the top of the board. The Restart pushbutton is located immediately below the LEDs. The RS-232 serial port with the RJ-11 connector is the Station Manager port. The RS-485 serial port with the 15-pin D connector located below the Station Manager port is the module's Downloader port. The 14-pin AAUI connector, facing downward, is the Transceiver port. The Default MAC Address label is attached to the outside of the plastic housing.

## Board Indicators

There are four LEDs on the Ethernet Interface: OK, LAN, SER, and STAT. These LEDs can be ON, OFF, BLINKING slow, or BLINKING fast. They indicate the state the Interface is in, traffic on the Transceiver port and Downloader port, and when an exception event has occurred.

## Restart Button

The Restart button serves four functions: LED test, Restart, Restart and Reload, and Restart and Enter Maintenance Utility. The Restart button is inaccessible when the front cover of the Ethernet Interface is closed.

## Serial Ports

There are two serial ports on the Ethernet Interface: the Station Manager Port and the Downloader Port.

## The Station Manager Port

This RS-232 port is used to connect a terminal or terminal emulator to access the Station Manager software on the Ethernet Interface. This port uses a 6-pin, RJ-11 connector. The IC693CBL316 Station Manager cable is ideal for connecting to this port (see Chapter 10 for details).

## The Firmware Upgrade Port

The 15-pin, D-type, RS-485 port is used to connect to the PC Downloader in case the communications software in the Ethernet Interface needs to be updated. Use the IC690ACC901 miniconverter/cable kit for this connection (see Appendix F for details).

## AAUI (Transceiver) Port

The 14-pin AAUI port connects to an external Ethernet-compatible transceiver via an IEEE 802.3 transceiver cable. GE Fanuc catalog number IC649AEA102 (for 10Base T) or IC649AEA103 (for 10Base 2) are suitable transceivers (see Appendix L for details).

## Default MAC Address Label

The Default MAC Address label lists the Ethernet MAC address to be used by this module.

## Serial Number Label

The Serial Number Label indicates the serial number of this Interface.

## Ethernet Interface Module Documentation

For detail, refer to GFK- 1541, *Series 90-30 TCP/IP Ethernet Communications User's Manual*.

## IC693PCM300/301/311 Programmable Coprocessor Module (PCM)

The Programmable Coprocessor Module (PCM) is a high performance coprocessor for the Series 90-30 Modular CPUs (will not work with Embedded CPU models 311, 313, or 323). The PCM supports the Modbus RTU and GE Fanuc CCM protocols, as well as the MegaBasic and C programming languages. A free program for using this module as an RTU Master can be downloaded from the GE Fanuc website. The PCM has two separate ports, both accessed on one front panel connector.

The PCM is available in three versions. Each version is listed below with the total memory on the board and the nominal user-available MegaBasic program memory size.

| PCM Catalog Number | Total Memory | User Megabasic memory |
|--------------------|--------------|-----------------------|
| IC693PCM300        | 160K         | 35K                   |
| IC693PCM301        | 192K         | 47K                   |
| IC693PCM311        | 640K         | 190K                  |

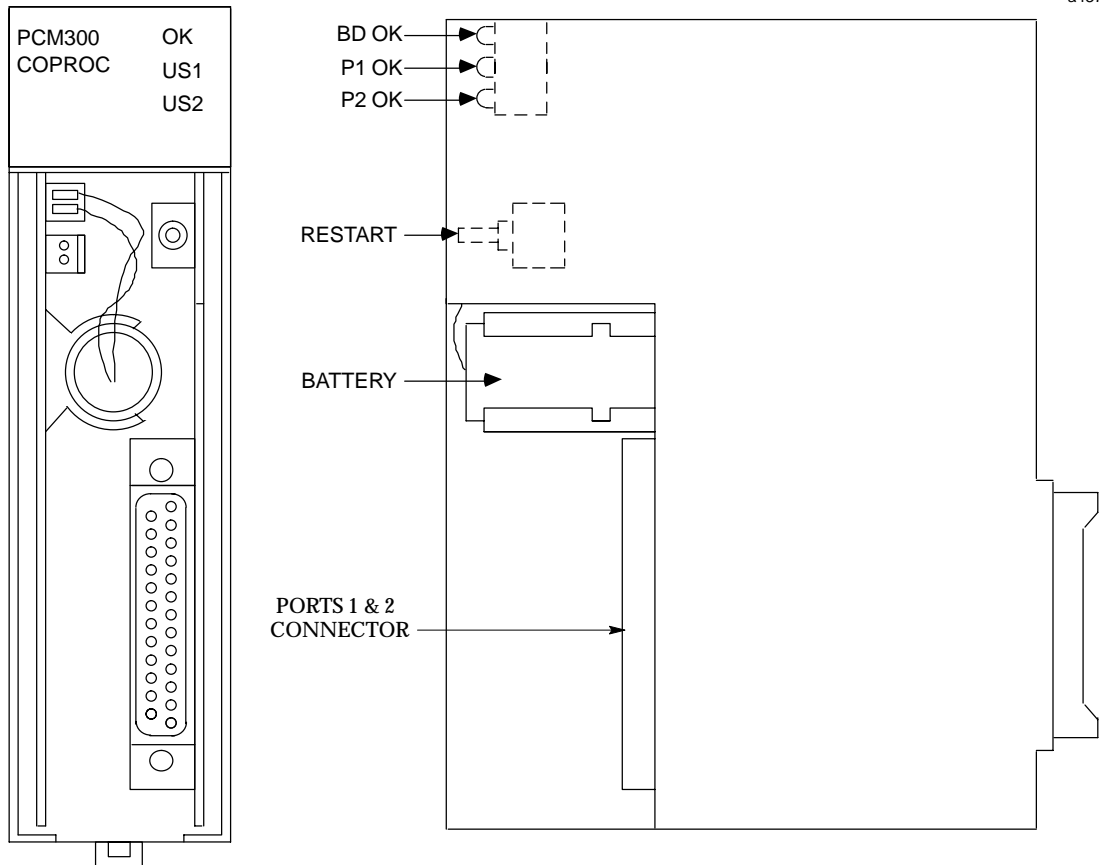

Figure 8-19. Programmable Coprocessor Module (PCM)

### Applications

These modules are used for communicating with programming terminals, CRTs, bar code readers, scales, printers, ASCII devices, RTU master devices, etc.

## PCM Module Location

A PCM can be installed in any slot in the CPU baseplate only, except slot 1 (labeled CPU/1), which must contain the CPU module. A PCM will not work in Expansion or Remote racks or in an Embedded CPU (CPU311, 313, or 323) rack.

## Protocols Supported

Modbus RTU and GE Fanuc CCM.

## LED Indicator Lights

- **OK** –Normally ON. Indicates the basic condition of the module.
- **US1 and US2** – By default, LED US1 flashes to indicate activity on Port 1, and LED US2 flashes to indicate activity on Port 2. Both LEDs stay OFF when there is no port activity. However, the function of these two LEDs can be custom configured by the user. Please see GFK-0255 for custom configuration details.

## Restart Pushbutton

Used to place the module in either the RUN mode or the PROGRAM mode. Please see “PCM Operation Modes” in GFK-0255, Chapter 1.

## Memory Backup Battery

The Lithium battery for backup of RAM memory is installed in a battery mounting clip on the inside of the PCM faceplate. This battery is disconnected for shipment from the factory and must be connected prior to installation of the module. When the PCM is stored for extended periods of time, the battery should be disconnected, unless you wish to retain the program in RAM memory. Order replacement batteries using catalog number IC693ACC301 (package of two).

## Cables

**IC693CBL304/305** – These Wye cables split out the two PCM port connections from the single connector on the front of the PCM modules. One of these cables is supplied with each PCM module. The IC693CBL304 is for the PCM300. The IC693CBL305 is for the PCM301 and PCM311. Please see Chapter 10 for details on these cables.

**IC690CBL701/702/705** – These cables provides a direct RS-232 connection between the PCM and various programmers’ serial ports. These cables are not supplied with the PCM modules. Please see Chapter 10 for details on these cables.

## Programmable Coprocessor Module Documentation

- GFK-0255, *Series 90 Programmable Coprocessor Module and Support Software User’s Manual*
- GFK-0256, *Megabasic Language Reference and Programmer’s Guide Reference Manual*
- GFK-0487, *Series 90 PCM Development Software (PCOP) User’s Manual*
- GFK-0771, *C Programmer’s Toolkit for Series 90 PCMs User’s Manual*

## IC693CMM311 Communications Coprocessor Module (CMM)

The Communications Coprocessor Module (IC693CMM311) provides a high performance coprocessor for all Series 90-30 modular CPUs (cannot be used with embedded CPUs – models 311, 313, or 323). This module supports the GE Fanuc CCM communications protocol, the RTU (Modbus) slave communications protocol, and the SNP protocol. This module has two serial ports. Port 1 supports RS-232 applications and Port 2 supports either RS-232 or RS-485 applications. The module can be configured using Logicmaster or VersaPro or by using a default setup.

Since both serial ports are wired to the module's single connector, an IC693CBL305 Wye cable is supplied with this module to separate the two ports for ease of wiring. A system with a 331 or higher CPU can have up to four CMMs (in the CPU baseplate only).

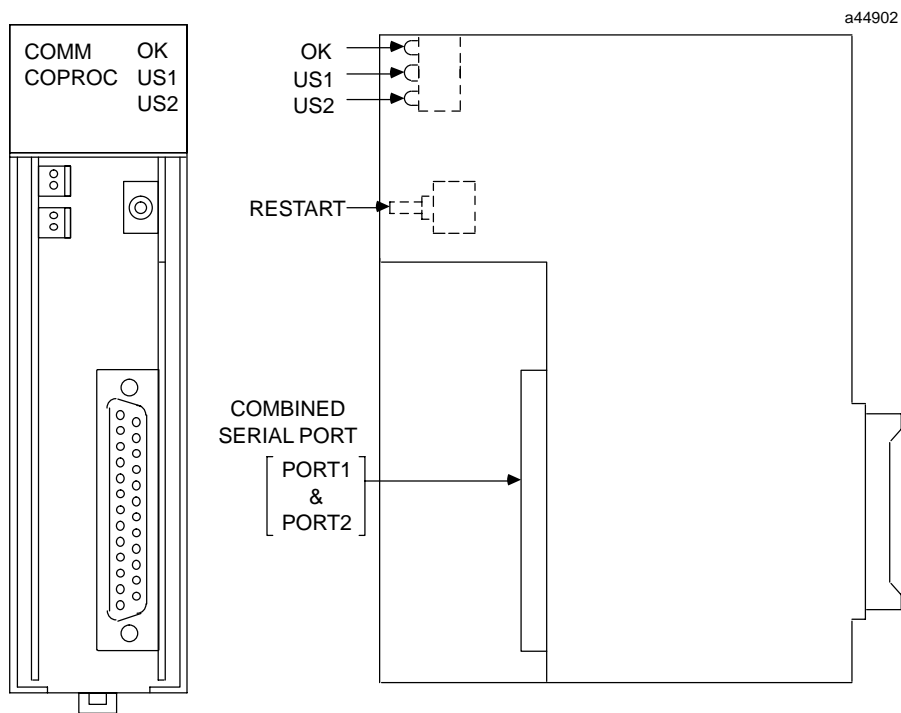

Figure 8-20. Communications Control Module

### Communications Control Module Documentation

For more information, refer to GFK-0582, the *Series 90 PLC Serial Communications Driver User's Manual*.

## IC693ADC311 Alphanumeric Display Coprocessor (ADC)

The Alphanumeric Display Coprocessor module (IC693ADC311) is a coprocessor to the Series 90-30 PLC CPU and is used in a CIMPLICITY 90-ADS system. It performs CIMPLICITY 90-ADS display, report, and alarm functions when interfaced to an Operator Interface Terminal (OIT). The OIT can be a variety of GE Fanuc devices, a VT100 compatible terminal, or IBM compatible personal computer running TERME. Communications with the Series 90-30 CPU is done over the PLC system backplane.

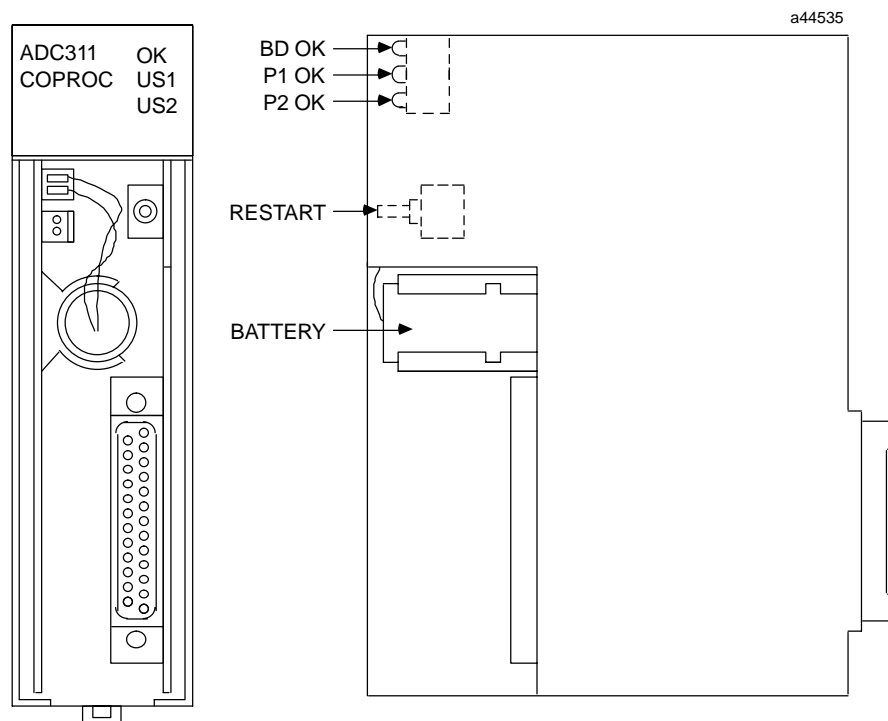

Figure 8-21. Alphanumeric Display Coprocessor Module (ADC)

Features of the Alphanumeric Display Coprocessor include:

- Single slot module
- Runs CIMPLICITY 90-ADS System software
- 8 Mhz, 80C188 microprocessor
- High performance access to PLC memory
- Real time calendar clock synchronized to PLC
- Reset pushbutton; three status LEDs
- Soft Configuration (No DIP switches or jumpers)
- Easy fill-in-the-blank system building
- Pop-up windows; pull down menus
- Fifteen User definable function keys per screen
- Printer logging to a serial printer

Multiple Alphanumeric Display Coprocessors can be supported in a single Series 90-30 PLC system with modular CPU (331 and higher) and must be located in the CPU baseplate. This

module has a single connector which supports two serial ports, with each port being dedicated to a specific operation. Port 1 is most often used to connect to an RS-232 serial COM port of a computer running GE Fanuc PCM Development Software (PCOP). Alternately, port 1 may be connected to a serial RS-232 printer (see the “Cables” section below). By default, Port 2 is configured as a 19.2 Kbaud RS-232 port. It can be used to interface to a terminal with keyboard input and screen output.

Serial port programming and configuration are done using a Workmaster II, Workmaster, or an IBM-compatible PC, XT, AT, or PS/2 computer with PCM Development Software (PCOP) installed. The programming computer connects to Port 1 (see the “Cables” section below). The default setting is 19,200 bps. The PCM Development Software is used to configure the serial port parameters and to install the CIMPPLICITY 90-ADS software onto the ADC.

There are no DIP switches or jumpers on this board that need to be set for configuration. The ADC module must be configured with LogiCmaster 90-30 or VersaPro software prior to use.

### Cables

**IC693CBL305** – This Wye cable is used to split out the two ADC port connections from the single connector on the front of the ADC module. This cable is supplied with the module. Please see Chapter 10 for details on this cable.

**IC690CBL702** – This cable provides a direct RS-232 connection between the ADC and another serial device such as a Personal Computer. This cable is not supplied with the module. Please see Chapter 10 for details on this cable.

### Alphanumeric Display Coprocessor Module Documentation:

See the following manuals for detailed information on Series 90-30 Alphanumeric Display Coprocessor Modules:

- GFK-0499 *CIMPPLICITY 90-ADS Alphanumeric Display System User's Manual*
- GFK-0641 *CIMPPLICITY 90-ADS Alphanumeric Display System Reference Manual*
- GFK-0487 *Series 90-30 PCM Development Software (PCOP) User's Manual*

## IC693TCM302/303 Temperature Control Modules (TCM)

The Temperature Control Modules (TCM) provides temperature control for up to eight channels. The two TCM models are identical except for temperature range and resolution ratings (see comparison table). They have the following features:

- Can operate in either open loop or closed loop mode
- Each channel has a thermocouple input and a relay output
- RTD input
- 12V common mode voltage capability
- Open and reverse thermocouple detection and reporting
- Out of tolerance temperature detection and reporting

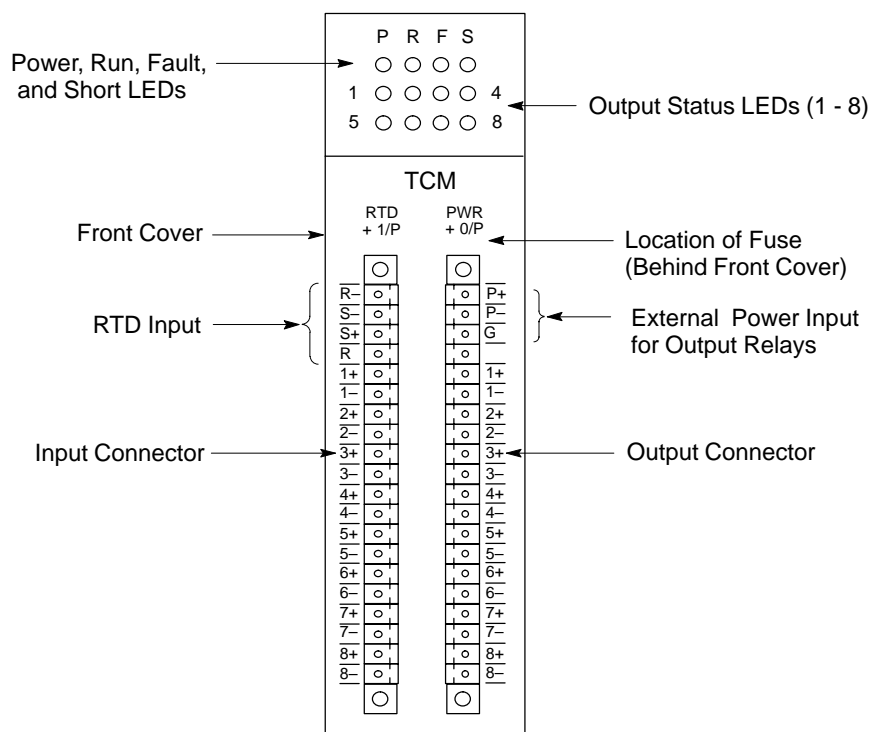

Figure 8-22. IC693TCM302/303 Temperature Control Module (TCM)

### Connections

Field devices (thermocouples, relays), RTD and external power for output relays are connected to the module using a pair of plug-in connectors which are supplied with the module. These connectors have captive screw terminals for ease of connecting field wiring. The signal name for each terminal is labeled on the module's front cover next to each connector, as shown in the drawing above. For example, Channel 8 connections are labeled 8+ and 8- on each connector. Input connections are on the left-hand connector and output connections are on the right-hand connector.

## LED Indicators

- **P (External Power)** – This green LED is normally ON, indicating that the module is receiving power. If this LED is OFF, it may indicate that the TCM's internal fuse is open.
- **R (Run)** – This green LED is normally ON. When there is an internal module fault, this LED will alternately flash with the red Fault (F) LED.
- **F (Fault)** – This red LED is normally OFF. This light flashes upon module startup and goes out when the TCM finishes its internal startup routine. When there is an internal module fault, this LED will alternately flash with the green Run (R) LED.
- **S (Short)** – This red LED is normally OFF. This LED lights when there is a short on one of the output circuits.
- **1 - 8 (Output Status)** – These green LEDs normally turn ON and OFF while the module is regulating their outputs. The percentage of time that one of these LEDs is ON versus OFF is representative of the PWM period of that output. Each of the eight LEDs corresponds to an output channel. The output connector is the one on the right side of the module. The channels numbers are labeled on the module next to the connector. For example, LED 8 corresponds to the connections labeled 8+ and 8- on the right-hand connector.

## Internal Fuse

The TCM's internal fuse is a 2 Amp, 125V subminiature type (Littlefuse Microfuse, Catalog Number 273 002 or equivalent). If the P (External Power) LED will not light, the internal fuse may be open. To access this fuse:

- Turn off power to the PLC, then remove the TCM module.
- While gently pulling outward on the front cover, release the front cover side tabs with a small ("pocket-size") standard screwdriver.
- Gently remove the fuse by pulling it forward, out of the front of the module, with a small pair of needle nose pliers.

### Warning

**Replace fuse only with the correct size and type. Using an incorrect fuse can result in harm to personnel, damage to equipment, or both.**

## Automatic Data Transfers Between TCM and PLC

The PLC CPU controls the TCM by automatically passing commands to it on each PLC sweep. These commands are contained in %Q bits and %AQ words that command such things as Enable/Disable Output, Auto/Manual Mode, Do Autotuning, Setpoint values, and Alarm Limit values.

In return, the TCM sends information to the PLC CPU by automatically passing %I bits and %AI words each PLC sweep. The information sent by the TCM includes Alarm and Output Short Circuit status, Current Temperature, PWM Period, and TCM Error Code.

## Comparison of TCM302 and TCM303 Modules

The following table describes the only differences between the TCM302 and TCM303 modules.

Table 8-1. Comparison of TCM302 and TCM303

| Item                                     | IC693TCM302          | IC693TCM303          |
|--|----------------------|----------------------|
| Temperature range, J and L Thermocouples | 0 - 450 deg. C       | 0 - 750 deg. C       |
| Temperature range, K Thermocouples       | 0 - 600 deg. C       | 0 - 1050 deg. C      |
| Resolution                               | 12 bits / 0.2 deg. C | 12 bits / 0.5 deg. C |

## Documentation

Please refer to GFK-1466, *Temperature Control Module for the Series 90-30 PLC User's Manual*. Note that GFK-1466 does not mention the TCM303. It will be included in the next revision (Revision A) of the manual, when available. However, the TCM303 is just an extended range TCM302 as shown in the comparison above.

## IC693PTM100/101 Power Transducer (PTM)– Preliminary

### Note

**This information was preliminary at the time of writing and could change by the time the product is released. The PTM is expected to be available early in the year 2000. Please contact your distributor for up-to-date information.**

The PTM is used for measuring electrical power consumption or for monitoring voltages between an electrical generator and its power grid. It connects to user-supplied current and potential transformers, which furnish the input signals the PTM uses to calculate its data. Since one of the PTM's components is a Series 90-30 PLC module, the PLC can use the data gathered by the PTM for data reporting, fault monitoring, generator control, or demand charge reduction/load shedding applications. The PTM consists of three parts, which are all included under one catalog number:

- **PTM Processing Module (PTMPM)** – a module that mounts in a Series 90-30 Rack.
- **PTM Interface Module (PTMIM)** – a panel-mounted circuit board. This board interfaces between the PTMPM module and the input transformers (current and potential).
- **Interface cable** – connects the PTMPM module to the PTMIM circuit board.

### Difference Between PTM100 and PTM101

The only difference between the IC693PTM100 and IC693PTM101 is in the length of their interface cables. The PTM100 comes with a 19" (0.5 meter) cable, and the PTM101 comes with a 39" (1 meter) cable.

### Capabilities

A single PTM is capable of performing any one of the following tasks, as selected by the appropriate %Q bit:

- Measure power parameters for three individual single phase circuits.
- Measure power parameters for one 3-wire single phase circuit (120/240 VAC).
- Measure power parameters for one 3-phase circuit (selectable between Wye or Delta type).
- Measure and compare power parameters between a 3-phase generator's output phases and one power grid phase.
- Measure and compare power parameters between one generator output phase and one power grid phase.

### Operating Modes

The PTM can operate in either of the following two modes, which are selectable by a %Q bit in the user's PLC application program:

- **Power Monitor Mode** – In this mode, the PTM samples either Single Phase or 3-Phase AC voltages and currents and uses the data to calculate numerous power values. For 3-Phase operation, Wye or Delta, can be selected.
- **Synchro Monitor Mode** – In this mode, the PTM samples a Single-Phase or 3-Phase AC voltage produced by a generator, and one voltage from the associated power grid, then develops voltage, frequency, and relative phase information.

## Automatic Data Transfers Between PTMPM and PLC

The PLC CPU controls the PTM Processor Module (PTMPM) by sending it several %Q bits and %AQ words during each PLC sweep. These %Q bits and %AQ words represent commands such as Enabled/Disabled, Power/Synchro Mode, Display Mode, and Gain values.

In return, the PTMPM provides information to the PLC CPU by sending it several %I bits and %AI words each PLC sweep. The information sent by the PTMPM includes voltage, current, power, and phase values, as well as discrete fault status.

## Compatibility

The PTM is compatible with all Series 90-30 CPUs, and the PTMPM module may be mounted in any type of baseplate (CPU, Expansion, Remote).

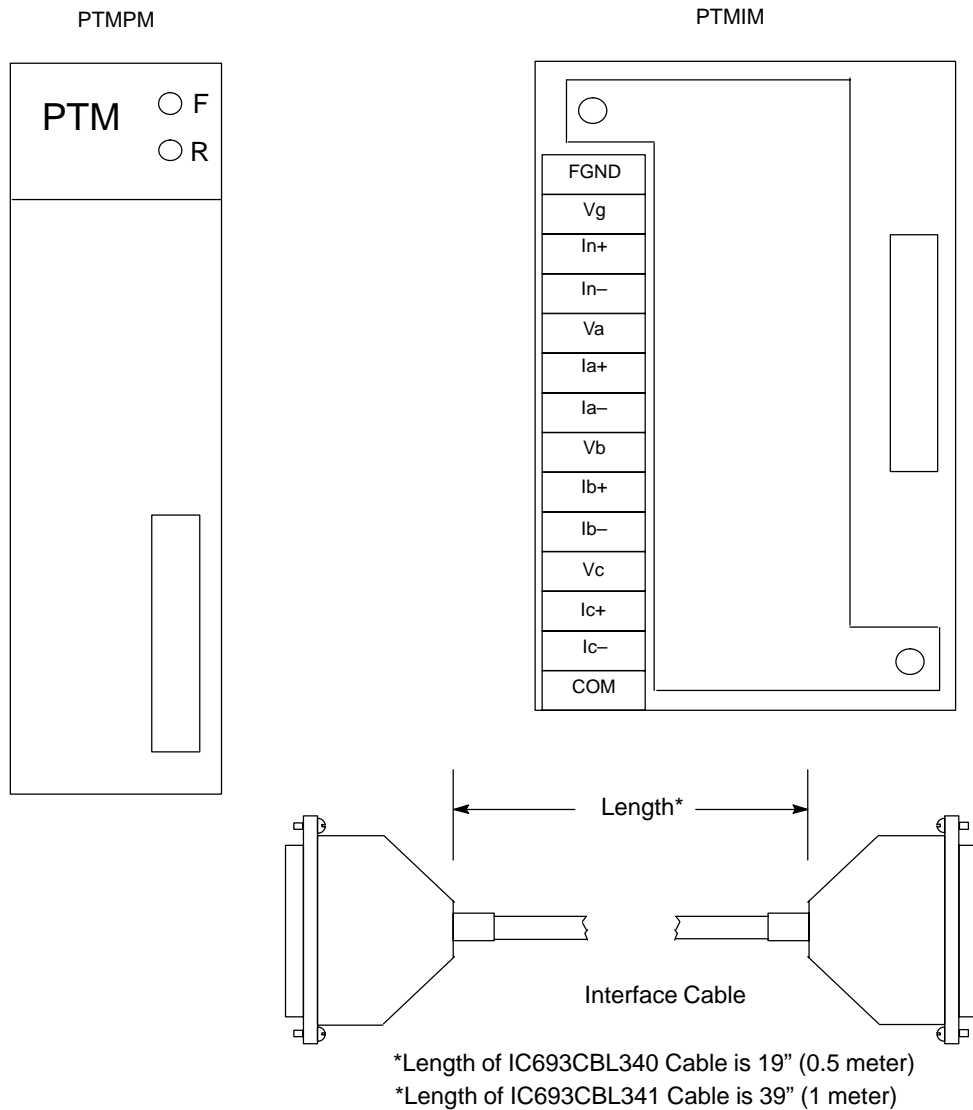

Figure 8-23. IC693PTM100/101 Components

## Dimensions

- **PTMPM** – Standard size Series 90-30 module, mounts in a Series 90-30 baseplate.
- **PTMIM** – Interface module. Approximately 4.5” (114 mm) long by 3” (76 mm) wide. It is mounted on a standard 35 mm DIN-rail.
- **IC693CBL340 Interface cable** – Approximately 19” (0.5 Meter) long.
- **IC693CBL341 Interface cable** – Approximately 39” (1 Meter) long.

## PTMPM Indicator LEDs

- **F (Fault)** – This RED LED, when OFF, indicates that there are no interface faults. When ON, either steady or flashing, it indicates that one or more of three possible faults is present: (1) Phase A input not present, (2) over-range condition on one or more inputs (voltage or current values too high), and (3) phase polarity fault. Each of these three fault signals has a %I status bit in the PLC.
- **R (Running)** – This Green LED, when ON, indicates that the module is “running” (functioning properly). When OFF, it indicates a module failure.

## General Mounting Information

It is recommended the PTMPM modules be mounted in a slot at or near the end of the PLC and that the PTMIM be mounted to the panel to the side of the PLC (the PTMIM mounts on a standard DIN-rail). This will keep the power wiring to the PTMIM physically separated from PLC signal wiring, thus reducing the opportunity for noise coupling. **The PTMIM ground requirements must be strictly adhered to – refer to the user’s manual (GFK-1734 when available in early 2000) for instructions. See Warning note below.**

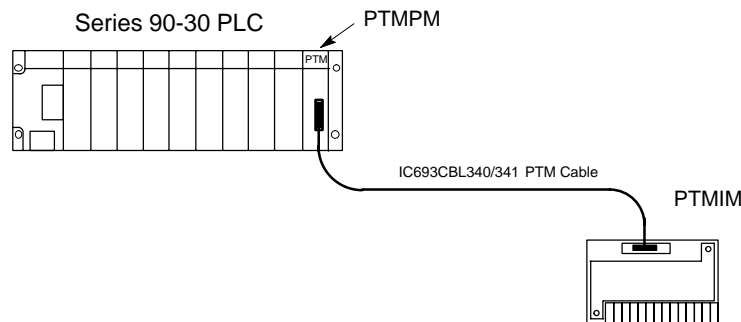

Figure 8-24. IC693PTM100/101 Component Mounting

### Warning

**The PTMIM board connects to hazardous voltages. Before installing, testing, or troubleshooting this board, you should read the complete instructions in the PTM User’s Manual, GFK-1734 (see “Documentation” section below). Failure to follow the guidelines in the PTM User’s Manual may result in personal injury, equipment damage, or both.**

## Baseplate Type and Allowable Number of PTMPM Modules

The PTMPM module may be installed in any type of Series 90-30 baseplate (CPU, Expansion, or Remote). There are no restrictions as to the maximum number of PTMPM modules per PLC system, or per PLC baseplate, as long as the PLC power supply has sufficient capacity and there is sufficient %I, %Q, %AI, and %AQ memory available. However, as noted in the “Mounting Information” section, it is beneficial to keep the PTMIM power wiring physically separated from PLC signal wiring in order to reduce noise coupling; this can have a bearing on which baseplate slots to choose when mounting PTMPM modules.

## Power Supply Requirement

The PTMPM module requires 400 mA @ 5 VDC from the PLC power supply. The PTMIM does not require a control power input.

## Memory Requirement

Each PTMPM requires the following PLC memory allocation:

- %I – 16 bits
- %Q – 16 bits
- %AI – 25 words
- %AQ – 2 words

## Configuration

The PTMPM module should be configured in the Series 90-30 PLC as a “Foreign” module.

## PTM Acronyms

- **PTM**                    Power Transducer. Consists of PTMPM, PTMIM, and interface cable.
- **PTMPM**                Power Transducer Processor Module
- **PTMIM**                Power Transducer Interface Module

## Ordering Information

The PTMPM module and its PTMIM interface board are considered to be a matched set and, therefore, they are not sold separately. The two cables, however, may be ordered as separate items. There are four catalog numbers in the PTM product line:

- IC693PTM100 – This system contains the PTMPM, its matched PTMIM, and the 19” (0.5 meter) interface cable.
- IC693PTM101 – This system contains the PTMPM, its matched PTMIM, and the 39” (1 meter) interface cable.
- IC693CBL340 – The 19” (0.5 meter) interface cable.
- IC693CBL341 – The 39” (1 meter) interface cable.

## Documentation

The user’s manual will not be available until early in the year 2000. It will be GFK-1734, *Series 90-30 PLC Power Transducer User’s Manual*.

# Chapter *State Logic Products*

## 9

[efesotomasyon.com](http://efesotomasyon.com)

---

---

### State Logic Overview

State Logic, unlike other Series 90-30 PLC systems, does not use ladder logic type instructions. Instead, it uses "Natural Language" programming instructions. For example, to program a rung of logic that turns on a motor at a specific time in a State Logic system, you could create a statement, "If hour is past 8 AM, start the exhaust\_system." This type of programming instruction cannot be handled currently by standard Series 90-30 CPUs, so a State Logic CPU is required. This chapter only provides an overview of State Logic products. For details, please see *GFK-1056, Series 90-30 State Logic Control System User's Manual*.

### State Logic Products

The State Logic product line consist of just a few key hardware and software items. To complete a State Logic system, standard Series 90-30 products are used. The primary State Logic products are:

- **State Logic CPUs.** There are five models: 311, 313, 323, 331, and 340.
- **State Logic Processor Module (IC693SLP300).** This module can reside in a Series 90-30 PLC system containing a standard CPU, providing the user with both standard ladder logic and State Logic capabilities.
- **Serial Communications Module (AD693CMM301).** Provides two additional serial ports for the State Logic system. Requires a 331 or 340 State Logic CPU.
- **ECLiPS software.** Provides Natural Language programming and online debugging functions.
- **OnTOP software.** A debugging tool, it provides operator interface, maintenance, or troubleshooting functions. It has all the capabilities of the ECLiPS debugging function.

### Baseplates and Power Supply, I/O, and Option Modules

The State Logic CPUs and modules work with most standard Series 90-30 baseplates, power supplies, input and output modules (discrete and analog), and option modules. Please see *GFK-1056, Series 90-30 State Logic Control System User's Manual*, for details.

## AD693CMM301 State Logic Serial Communications Module (SCM)

### Description

This module provides two additional serial ports for a Series 90-30 State Logic PLC System. A model 331 or 340 State Logic CPU is required.

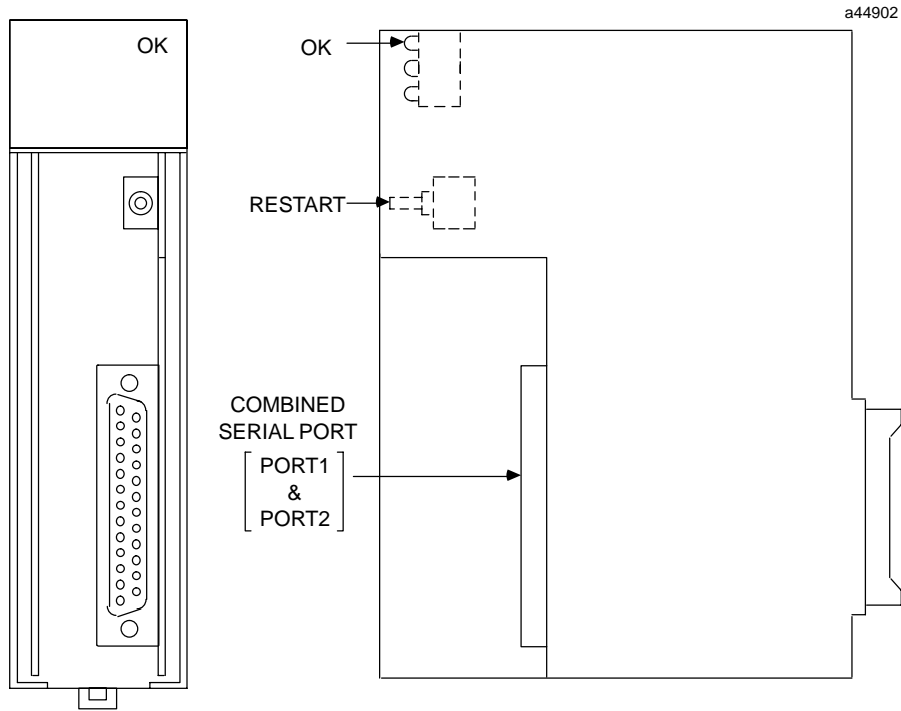

Figure 9-1. AD693CMM301 State Logic Serial Communications Module

### OKLED

The SCM turns on its OK LED after completing its start-up internal self test procedure. The OK LED remains ON as long as the module is functioning properly. If the OK LED turns OFF while power is applied to the system, turn OFF PLC power and make sure the module is properly seated in the baseplate. Turn power back ON. If the OK LED remains OFF when power comes back up, it indicates a probable hardware failure in the SCM and it should be returned for repair. The other two LEDs on this module are not used.

### Reset Button

Pressing the Reset pushbutton when the OK LED is ON re-initializes the module. However, if the OK LED is off (indicating a module failure), pressing the Reset button will have no effect.

### Serial Connector

The SCM front-mounted serial port connector provides all of the connections for the two SCM serial ports. Separate pins on this connector are assigned for Port 1 and Port 2.

Both ports support RS-232 standard. Only Port 2 supports the RS-485 standard. A special WYE cable, described below, is available from GE Fanuc to separate the two port connections on the connector.

### Cable Information

Cable IC693CBL305 can be used in applications that require use of both SCM serial ports. This is a Wye-type cable that breaks out the Port 1 and Port 2 connections on the module's single connector to two individual connectors. A data sheet for this cable can be found in the "Cables" chapter of this manual. (Additional SCM cable information is found in the two documents referenced in the next section.) This cable wouldn't be required for applications that use only one SCM port. Also, this cable **should not be used** in a multidrop network (see Caution note below).

**Caution**

**The IC693CBL305 Wye cable should not be used with an SCM connected to a multidrop network because it introduces signal reflections on the network. Multidrop networks should be cabled directly to the SCM serial connector.**

a44225

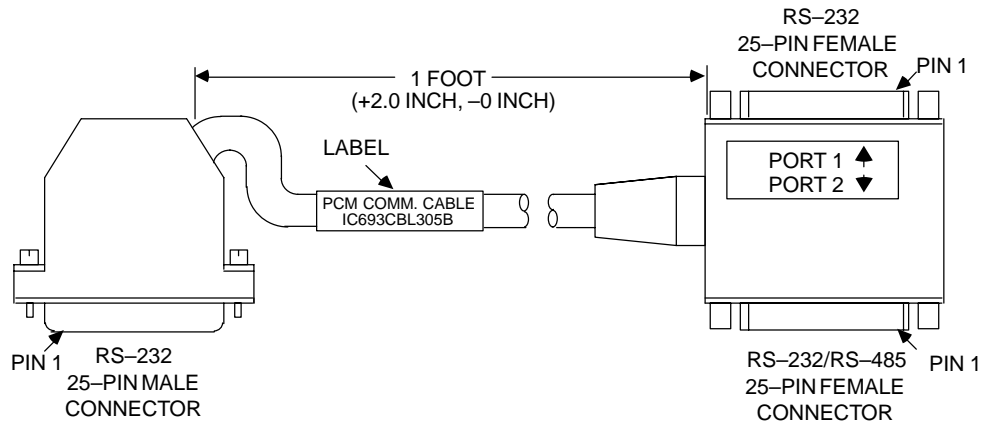

Figure 9-2. IC693CBL305 WYE Cable

### State Logic SCM Documentation

- GFK-1661 (Data Sheet), *Serial Communications Module, Series 90-30 State Logic*
- GFK-1056, *Series 90-30 State Logic Control System User's Manual*

## IC693SLP300 State Logic Processor Module

### Description

The **State Logic Processor Module (SLP)** installs in a Series 90-30 PLC ladder logic control system to provide real time multi-tasking control for machine and process applications. It can be programmed to perform computations, data acquisition, data communications and operator interface functions. Also, the SLP module can provide machine or process simulation capabilities to Series 90-30 PLC ladder logic control system to help reduce debug and startup times. This dual processor architecture allows a user to create both ladder logic and state logic application programs in any combination for efficient parallel processing solutions.

The SLP is programmed using the English Control Language Programming System (ECLiPS) software package. It communicates with the PLC CPU over the backplane and can access user and system data. Many SLPs can be supported in a single Series 90-30 PLC system and each SLP can support up to 512 inputs and 512 outputs.

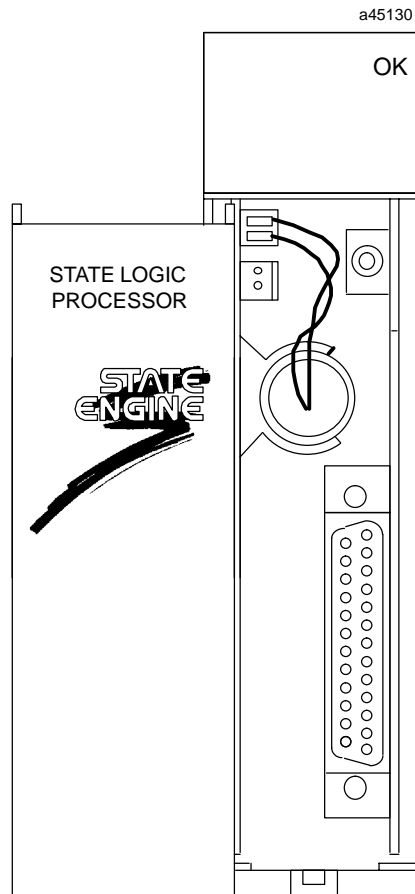

Figure 9-3. IC693SLP300 State Logic Processor Module for Series 90-30

## SLP Features

- Natural English Language Programming using ECLiPS™
- Structured State Logic program architecture
- Advanced Diagnostics
- Simulation capabilities
- PID Loop control
- Handles complex math easily (floating point, square root, trig. functions)
- Allows any combination of Natural English State Logic and Ladder Logic programs in same system
- Configurable to operate with a Series 90-30 PLC system that uses a model 331, 340, or 341 CPU
- Up to 512 inputs and 512 outputs
- CCM2 Protocol
- 8 Mhz, 80C188 microprocessor
- 46 Kbytes battery-backed CMOS logic memory on board
- One RS-422/RS-485 port and one RS-232 serial port
- Soft configuration (No DIP switches or jumpers)
- Restart/Reset Pushbutton
- OK Status LED
- Occupies a single slot in a Series 90-30 rack

## Memory

The SLP module has 46 Kbytes of user program memory space. Additional memory exists for Input, Output, Register, and other variable data. The battery which supports this memory is located on the SLP module, as shown in the following figure.

## Installation

- Installation should not be attempted without referring to the State Logic Processor User's Guide (see reference 1).
- The Series 90-30 SLP can only be installed in a Series 90-30 PLC system that uses a model 331, model 340, or model 341 CPU.
- Make sure rack power is off.
- Connect the battery to either of the battery connectors on the module (See figure G-3).
- Install the SLP Module in the rack.
- Turn on power.

The module should power up and blink the top LED, indicating that power up diagnostics are in progress. When the diagnostics have completed successfully the top LED stays on. The other LEDs on this module are not used and will always stay off.

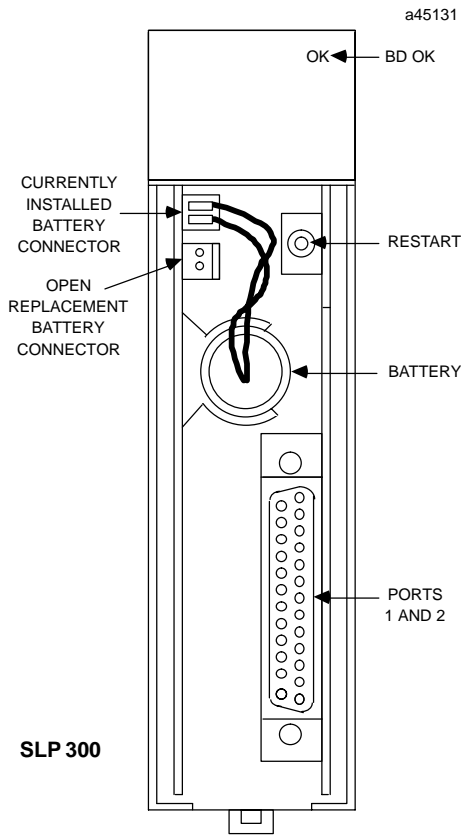

Figure 9-4. State Logic Processor Module User Details

### Status Light

Three Status LEDs exist on the SLP module. The top LED (see figure above) indicates the condition of the module. It will blink ON and OFF while the module is booting up, then will stay ON during normal operation. The bottom two LEDs are not used and will always be off.

### Pushbutton

**See Caution note below before operating the pushbutton.** One pushbutton is provided. Pushing and holding the pushbutton for less than 5 seconds will simply restart the user application program if it was configured to “auto-run” at power up. Pushing and holding for more than 5 seconds will reinitialize the module and require that the user application program be reloaded.

**Caution**

**Pushing and holding the pushbutton for more than 5 seconds will reinitialize the module and require that the user application program be reloaded.**

## Battery

A lithium battery (IC697ACC301) is installed as shown in the previous figure. This battery maintains user memory when power is removed. Be sure to install a new battery before removing the old battery (two connectors are provided). Indication of a low battery is provided through the ECLiPS programming system software and Logicmaster 90-30 software.

## Cable Information

Cable IC693CBL305 can be used in applications that require use of both SLP serial ports. This is a Wye-type cable that breaks out the Port 1 and Port 2 connections on the module's single connector to two individual connectors. A data sheet for this cable can be found in the "Cables" chapter of this manual. (Additional SLP cable information is found in publication GFK-0726 – see "Documentation" section.) This cable is not required for applications that use only one SLP port.

## Hardware Specifications

|                                   |  |
|-----------------------------------|--|
| <b>Battery:</b>                   |  |
| <b>Shelf Life</b>                 | 5 years at 20°C (68°F)                 |
| <b>Memory Retention</b>           | 6 months nominal without applied power |
| <b>Internal Power Consumption</b> | 400 mA from 5V bus on backplane        |
| <b>Serial Ports:</b>              | Two RS-232/422/485 compatible          |

## State Logic Processor (SLP) Documentation

Please refer to the following publications for more State Logic Processor information.

| Title   | GFK Number |
|---|------------|
| <i>Series 90-30 PLC State Logic Processor User's Guide</i>                              | GFK-0726   |
| <i>Series 90-30 PLC ECLiPS User's Manual</i>  | GFK-0732   |
| <i>Series 90-30 PLC OnTOP User's Guide</i>  | GFK-0747   |
| <i>OnTOP for Series 90-30 Online Troubleshooting and Operator Program User's Manual</i> | GFK-0750   |
| <i>Series 90-30 State Logic Control System User's Manual</i>                            | GFK-1056   |

## State Logic CPUs

Five models of State Logic CPUs are available that support State Logic programming. Three of these CPUs are of the embedded baseplate type, and two are modular CPUs. Data sheets for these modules are located at the back of this chapter. The available State Logic CPUs for the Series 90-30 PLC are:

- *IC693CSE311* and *IC693CSE313*, both are 5-slot embedded CPU (CPU is built-in) baseplates.
- *IC693CSE323*, 10-slot embedded CPU baseplate.
- *IC693CSE331* and *IC693CSE340*, single-slot CPU modules (can be installed in standard *IC693CHS397* 5-slot CPU baseplate, or standard *IC693CHS391* 10-slot CPU baseplate).

### Features of State Logic CPUs

- Support State Logic programming
- Support Floating Point calculations
- Support Clock/Calendar functions (CSE331 and 340 are battery backed)
- Support discrete and analog overrides
- Programmed by State Logic software products
- Provide from 10K to 98K Bytes of program memory depending on model
- Program memory is battery backed
- Control two Status LEDs on the power supply
- Software configuration (no DIP switches or jumpers to set)
- Serial port on power supply used as a programming port, a simple ASCII interface, or a CCM port
- Password controlled access
- Support Series 90-30 I/O products
- Alarm Processor Function for module diagnostics
- Simulation mode
- EPROM and EEPROM program memory
- Store histogram of State Changes

### Model CSE311, CSE313 and CSE323 Embedded CPU Baseplates

The Programmable Logic Controller with a built-in State Logic CPU is available in three models. The CSE311 and CSE313 with built-in CPU has 5 slots available for modules and the CSE323 with built-in CPU has 10 slots available for modules. Each baseplate also has a power supply slot.

The CSE 311, 313 and 323 CPUs can be programmed in the State Logic programming language using the State Logic software products. The State logic software products are also used to configure the Programmable Controller and communicate on-line with the State Logic CPU for debugging and troubleshooting operations.

The CSE311, CSE313, and CSE323 communicate with I/O modules, smart option modules, and Third Party modules across the PLC backplane. Most of the available Series 90-30 discrete, analog, and special purpose modules are supported (with Release 3.0 of State Logic). Foreign or 3rd party modules are also supported.

A socket labeled **PROGRAM PROM** is provided to install an EEPROM or EPROM. This option allows the control program to be stored in a PROM instead of RAM memory. It also is convenient in that it allows the PROM to be copied for installation in multiple CPUs.

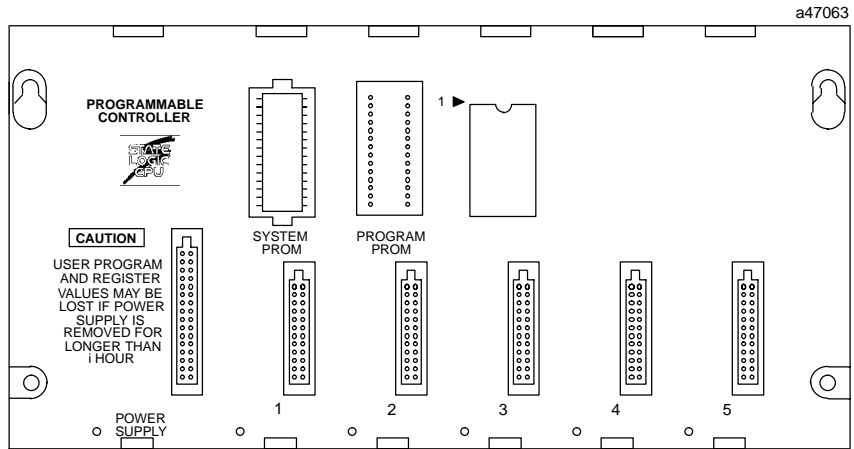

Figure 9-5. Model CSE311 or CSE313 5-Slot Embedded CPU Baseplate

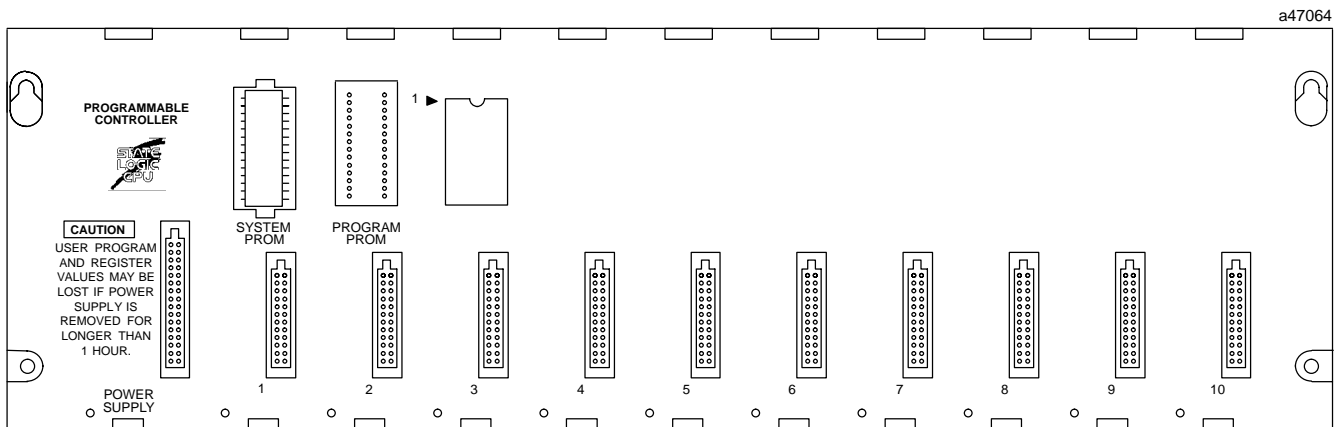

Figure 9-6. Model CSE323 10-Slot Embedded CPU Baseplate

## Model CSE331 and CSE340 Modular CPUs

The CSE 331 CPU (IC693CSE331) and CSE 340 (IC693CSE340) CPUs are single slot modules which must be installed in slot one (labeled CPU/1) of a CPU baseplate (IC693CHS391 or IC693CHS397). An illustration of the State Logic CPU modules is shown below.

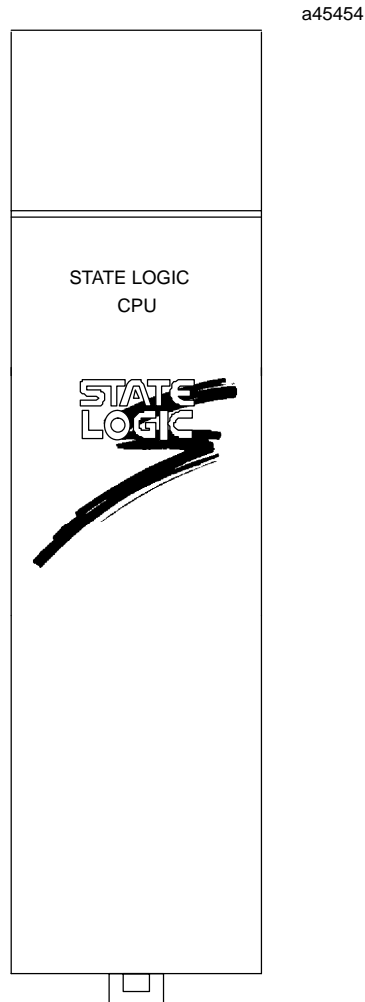

Figure 9-7. CPU Models CSE 331 or CSE 340

The CSE 331 and CSE 340 CPU modules provide the same functionality as the models CSE 311, 313 and 323, and offer several more advanced features such as more I/O points and more User Program memory. See the table at the end of this chapter to compare CPU specifications.

### CPU Serial Port Connector on Power Supply

The 15-pin D-connector provides the connection to an RS-485 compatible serial port. The connection is made from the serial port on the power supply to the serial port on the programming computer or other serial device through the RS-422/RS-485 to RS-232 Converter (IC690ACC900) or RS-422 to RS-232 Miniconverter (IC690ACC901).

The serial port has three possible uses:

- as a programming port for the State Logic software to download programs and to send instructions to the PLC;
- as an ASCII port providing a connection from the CPU to any ASCII device;
- as a CCM port providing an interface connection for MMI and other host computer systems.

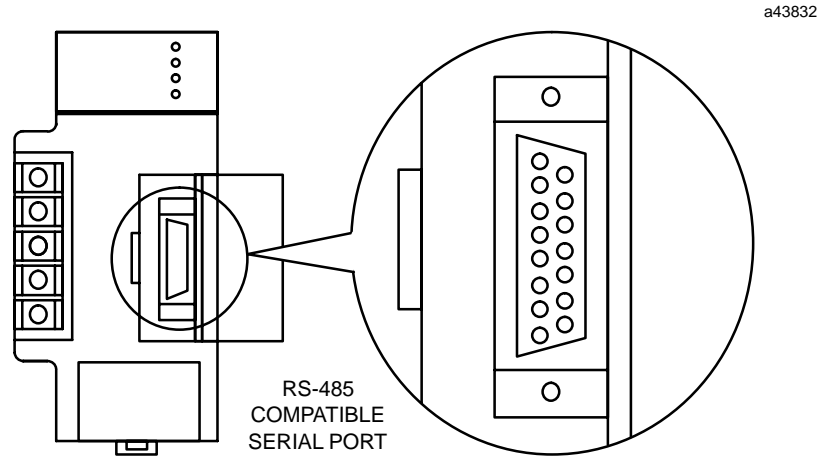

Figure 9-8. Serial Port Connector

### Notes

The serial port connector is functional only in a power supply that is installed in a baseplate that also contains the CPU; this includes the Model CSE 311 and CSE 313 5-slot baseplates with built-in CPU, CSE 323 10-slot baseplate with built-in CPU, and the Model CSE 331 and CSE 340 single slot CPUs.

*The serial port is not functional when a power supply is installed in a Series 90-30 expansion or remote baseplate.*

Additionally, any device connected to the serial port that uses +5 VDC power from the Series 90-30 power supply **must be included** in the calculation for maximum power consumption (see *Sample Calculations for Power Supply Loads* in Chapter 3 of this manual).

### Configuring the State Logic CPUs

All of the State Logic CPUs and attached I/O system are configured with the State Logic software. There are no DIP switches or jumpers used to configure the system. The CPU verifies the actual module configuration at power-up and periodically throughout the operation. The actual configuration must match the programmed configuration. Any detected deviations are reported to the CPU alarm processor function for the configured fault response. Refer to GFK-1056, the *Series 90-30 State Logic CPU User's Manual* for more information.

Table 9-1. System Specifications for Series 90-30 State Logic CPUs

|                          | State Logic CPU Model |               |                                       |           |
|--------------------------|-----------------------|---------------|---------------------------------------|-----------|
|                          | CSE 340               | CSE 331       | CSE 313/323                           | CSE 311   |
| Digital Inputs, %I       | 1024                  | 1024          | 512                                   | 512       |
| Digital Outputs, %Q      | 1024                  | 1024          | 512                                   | 512       |
| Global I/O, %G           | 1280                  | 1280          | 1280                                  | 1280      |
| Internal Flags           | 1000                  | 1000          | 500                                   | 500       |
| Analog Inputs, %AI       | 256                   | 256           | 128                                   | 128       |
| Analog Outputs, %AQ      | 128                   | 128           | 64                                    | 64        |
| PID Loops                | 20                    | 20            | 20                                    | 20        |
| Integer Variables        | 1000                  | 1000          | 250                                   | 250       |
| Floating Point Variables | 250                   | 250           | 61                                    | 61        |
| String Variables         | 20                    | 20            | 8                                     | 8         |
| Character Variables      | 64                    | 64            | 64                                    | 64        |
| Tables                   | 20                    | 20            | 10                                    | 10        |
| Program Memory           | 98K Bytes             | 48K Bytes     | 20K Bytes                             | 10K Bytes |
| Processor Speed          | 20 MHz                | 10 MHz        | 10 MHz                                | 10 MHz    |
| Number of Baseplates     | 5                     | 5             | 1                                     | 1         |
| Baseplate Size           | 5 or 10 slots         | 5 or 10 slots | 5 slots (CSE313)<br>10 slots (CSE323) | 5 slots   |
| Supports SCM             | Yes                   | Yes           | No                                    | No        |
| Serial Ports             | 1                     | 1             | 1                                     | 1         |
| Clock/Calendar           | Hardware              | Hardware      | Software                              | Software  |
| Table Memory Space       | 4K Bytes              | 4K Bytes      | 1K Bytes                              | 1K Bytes  |

For more detailed information on State Logic CPU specifications, see GFK-1056, the *Series 90-30 State Logic Control System User's Manual*.

## State Logic CPU Firmware and PROM Configurations

| State Logic CPU Firmware and PROM Table |                     |                         |                          |                         |
|---|---------------------|-------------------------|--------------------------|-------------------------|
| CPU                                     | Firmware (standard) | EPROM (for user memory) | EEPROM (for user memory) | Flash (for user memory) |
| CSE311                                  | EPROM               | Optional                | N/A                      | N/A                     |
| CSE313                                  | EPROM               | Optional                | N/A                      | N/A                     |
| CSE323                                  | EPROM               | Optional                | N/A                      | N/A                     |
| CSE331                                  | EPROM               | Optional                | N/A                      | N/A                     |
| CSE340                                  | EPROM               | N/A                     | N/A                      | Optional                |

---

## State Logic CPU Data Sheets

This section provides data sheets describing each of the Series 90-30 State Logic CPU modules. Each CPU is described in a one-page data sheet, which provides a quick reference to all of the available CPU models.

- IC693CSE311 State Logic, 5-slot baseplate with embedded CPU
- IC693CSE313 State Logic, 5-slot baseplate with embedded CPU
- IC693CSE323 State Logic, 10-slot baseplate with embedded CPU
- IC693CSE331 State Logic, CPU module, 10 MHz
- IC693CSE340 State Logic, CPU module, 20 MHz

# CSE311

## Catalog Number IC693CSE311

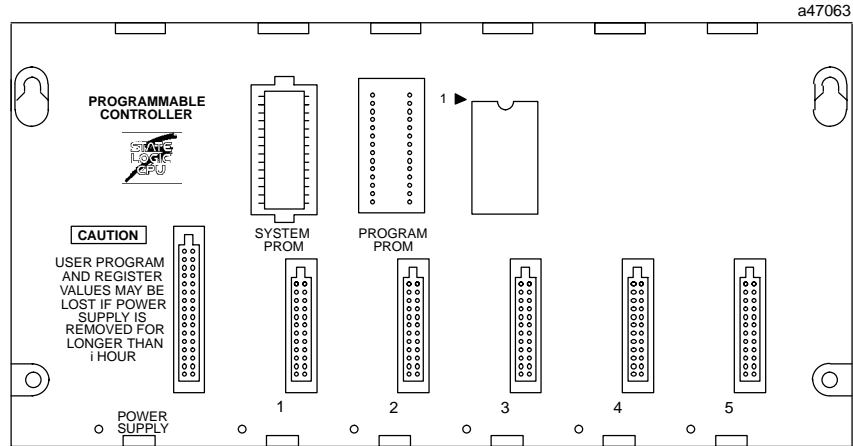

|  |  |
|--|--|
| <b>CPU Type</b>                        | State Logic 5-slot baseplate with embedded CPU     |
| <b>Total Baseplates per System</b>     | 1  |
| <b>Load Required from Power Supply</b> | 410 milliamps from +5 VDC supply                   |
| <b>Processor Type and Speed</b>        | 80188, 10 MegaHertz                                |
| <b>Typical Scan Rate</b>               | 18 milliseconds per 1K of logic (boolean contacts) |
| <b>Serial Ports</b>                    | 1  |
| <b>Type of memory Storage</b>          | RAM, EPROM, EEPROM                                 |
| <b>Clock</b>                           | Software   |
| <b>Program Memory</b>                  | 10K Bytes  |
| <b>Digital I/O (%I, %Q)</b>            | 1024   |
| <b>Tasks</b>                           | 256  |
| <b>Task Groups</b>                     | 16   |
| <b>States per task</b>                 | 254  |
| <b>I/O and Variable Names</b>          | 3000   |
| <b>Analog Inputs and Outputs</b>       | 128 (%AI), 64 (%AQ)                                |
| <b>Internal Flags</b>                  | 500  |
| <b>%G</b>                              | 1280   |
| <b>%T, %S, %M, %R</b>                  | n/a  |
| <b>Integer Variables</b>               | 250  |
| <b>Floating Point Variables</b>        | 61   |
| <b>String Variables</b>                | 8  |
| <b>Characters / String</b>             | 80   |
| <b>Character Variables</b>             | 64   |
| <b>Characters / Write</b>              | 512  |
| <b>Serial Protocols</b>                | SNP, CCM   |
| <b>Tables</b>                          | 10   |
| <b>Table Memory (Bytes)</b>            | 1K   |
| <b>Timers</b>                          | Unlimited  |
| <b>Timer Resolution</b>                | .01 seconds  |
| <b>Timer-Counters</b>                  | 100  |
| <b>Trace Size</b>                      | 100  |
| <b>PID Loops</b>                       | 20   |

# CSE313

## Catalog Number IC693CSE313

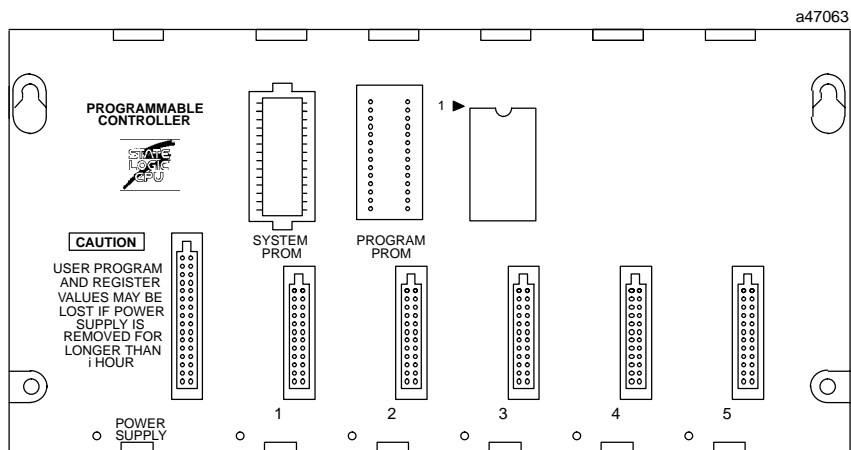

|  |   |
|--|---|
| <b>CPU Type</b>                        | State Logic 5-slot baseplate with embedded CPU      |
| <b>Total Baseplates per System</b>     | 1   |
| <b>Load Required from Power Supply</b> | 430 milliamps from +5 VDC supply                    |
| <b>Processor Type and Speed</b>        | 80188, 10 MegaHertz                                 |
| <b>Typical Scan Rate</b>               | 0.6 milliseconds per 1K of logic (boolean contacts) |
| <b>Serial Ports</b>                    | 1   |
| <b>Type of Memory Storage</b>          | RAM, EPROM, EEPROM                                  |
| <b>Clock</b>                           | Software  |
| <b>Program Memory</b>                  | 20K Bytes   |
| <b>Digital I/O (%I, %Q)</b>            | 1024  |
| <b>Tasks</b>                           | 256   |
| <b>Task Groups</b>                     | 16  |
| <b>States per task</b>                 | 254   |
| <b>I/O and VariableNames</b>           | 3000  |
| <b>Analog Inputs and Outputs</b>       | 128 (%AI), 64 (%AQ)                                 |
| <b>Internal Flags</b>                  | 500   |
| <b>%G</b>                              | 1280  |
| <b>%T, %S, %M, %R</b>                  | n/a   |
| <b>Integer Variables</b>               | 250   |
| <b>Floating Point Variables</b>        | 61  |
| <b>String Variables</b>                | 8   |
| <b>Characters / String</b>             | 80  |
| <b>Character Variables</b>             | 64  |
| <b>Characters / Write</b>              | 512   |
| <b>Serial Protocols</b>                | SNP, CCM  |
| <b>Tables</b>                          | 10  |
| <b>TableMemory (Bytes)</b>             | 1K  |
| <b>Timers</b>                          | Unlimited   |
| <b>Timer Resolution</b>                | .01 seconds   |
| <b>Timer-Counters</b>                  | 100   |
| <b>Trace Size</b>                      | 100   |
| <b>PID Loops</b>                       | 20  |

# CSE323

Catalog Number IC693CSE323

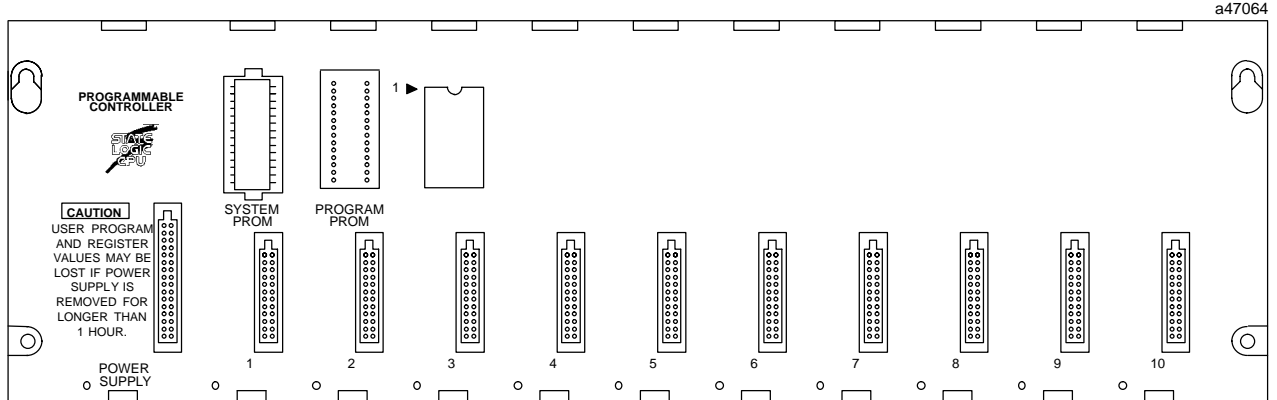

|  |   |
|--|---|
| <b>CPU Type</b>                        | State Logic 10-slot baseplate with embedded CPU     |
| <b>Total Baseplates per System</b>     | 1   |
| <b>Load Required from Power Supply</b> | 430 milliamps from +5 VDC supply                    |
| <b>Processor Type and Speed</b>        | 80188, 10 MegaHertz                                 |
| <b>Typical Scan Rate</b>               | 0.6 milliseconds per 1K of logic (boolean contacts) |
| <b>Serial Ports</b>                    | 1   |
| <b>Type of Memory Storage</b>          | RAM, EPROM, EEPROM                                  |
| <b>Clock</b>                           | Software  |
| <b>Program Memory</b>                  | 20K Bytes   |
| <b>Digital I/O (%I, %Q)</b>            | 1024  |
| <b>Tasks</b>                           | 256   |
| <b>Task Groups</b>                     | 16  |
| <b>States per task</b>                 | 254   |
| <b>I/O and VariableNames</b>           | 3000  |
| <b>Analog Inputs and Outputs</b>       | 128 (%AI), 64 (%AQ)                                 |
| <b>Internal Flags</b>                  | 500   |
| <b>%G</b>                              | 1280  |
| <b>%T, %S, %M, %R</b>                  | n/a   |
| <b>Integer Variables</b>               | 250   |
| <b>Floating Point Variables</b>        | 61  |
| <b>String Variables</b>                | 8   |
| <b>Characters / String</b>             | 80  |
| <b>Character Variables</b>             | 64  |
| <b>Characters / Write</b>              | 512   |
| <b>Serial Protocols</b>                | SNP, CCM  |
| <b>Tables</b>                          | 10  |
| <b>TableMemory (Bytes)</b>             | 1K  |
| <b>Timers</b>                          | Unlimited   |
| <b>Timer Resolution</b>                | .01 seconds   |
| <b>Timer-Counters</b>                  | 100   |
| <b>Trace Size</b>                      | 100   |
| <b>PID Loops</b>                       | 20  |

# CSE331

## Catalog Number IC693CSE331

a45454

|  |  |
|--|--|
| <b>CPU Type</b>                        | State Logic single slot CPU module                         |
| <b>Total Baseplates per System</b>     | 5 (1 CPU baseplate + 4 expansion and/or remote baseplates) |
| <b>Load Required from Power Supply</b> | 350 milliamps from +5 VDC supply                           |
| <b>Processor Type and Speed</b>        | 80188, 10 MegaHertz  |
| <b>Typical Scan Rate</b>               | 0.4 milliseconds per 1K of logic (boolean contacts)        |
| <b>Serial Ports</b>                    | 1  |
| <b>Type of Memory Storage</b>          | RAM, EPROM, EEPROM   |
| <b>Clock</b>                           | Hardware   |
| <b>Program Memory</b>                  | 48K Bytes  |
| <b>Digital I/O (%I, %Q)</b>            | 2048   |
| <b>Tasks</b>                           | 256  |
| <b>Task Groups</b>                     | 16   |
| <b>States per task</b>                 | 254  |
| <b>I/O and Variable Names</b>          | 3000   |
| <b>Analog Inputs and Outputs</b>       | 256 (%AI), 128 (%AQ)                                       |
| <b>Internal Flags</b>                  | 1000   |
| <b>%G</b>                              | 1280   |
| <b>%T, %S, %M, %R</b>                  | n/a  |
| <b>Integer Variables</b>               | 1000   |
| <b>Floating Point Variables</b>        | 497  |
| <b>String Variables</b>                | 20   |
| <b>Characters / String</b>             | 80   |
| <b>Character Variables</b>             | 64   |
| <b>Characters / Write</b>              | 512  |
| <b>Serial Protocols</b>                | SNP, CCM, RTU  |
| <b>Tables</b>                          | 20   |
| <b>Table Memory (Bytes)</b>            | 4K   |
| <b>Timers</b>                          | Unlimited  |
| <b>Timer Resolution</b>                | .01 seconds  |
| <b>Timer-Counters</b>                  | 100  |
| <b>Trace Size</b>                      | 100  |
| <b>PID Loops</b>                       | 20   |

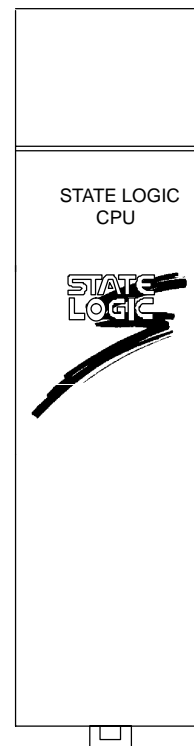

# CSE340

## Catalog Number IC693CSE340

|                                 |  |
|---------------------------------|--|
| CPU Type                        | State Logic single slot CPU module                         |
| Total Baseplates per System     | 5 (1 CPU baseplate + 4 expansion and/or remote baseplates) |
| Load Required from Power Supply | 490 milliamps from +5 VDC supply                           |
| Processor Type and Speed        | 80C188XL, 20 MegaHertz                                     |
| Typical Scan Rate               | 0.3 milliseconds per 1K of logic (boolean contacts)        |
| Serial Ports                    | 1  |
| Type of Memory Storage          | RAM, Flash, EEPROM   |
| Clock                           | Hardware   |
| Program Memory                  | 98K Bytes  |
| Digital I/O (%I, %Q)            | 2048   |
| Tasks                           | 256  |
| Task Groups                     | 16   |
| States per task                 | 254  |
| I/O and Variable Names          | 3000   |
| Analog Inputs and Outputs       | 256 (%AI), 128 (%AQ)                                       |
| Internal Flags                  | 1000   |
| %G                              | 1280   |
| %T,%S,%M,%R                     | n/a  |
| Integer Variables               | 1000   |
| Floating Point Variables        | 497  |
| String Variables                | 20   |
| Characters / String             | 80   |
| Character Variables             | 64   |
| Characters / Write              | 512  |
| Serial Protocols                | SNP, CCM, RTU  |
| Tables                          | 20   |
| Table Memory (Bytes)            | 4K   |
| Timers                          | Unlimited  |
| Timer Resolution                | .01 seconds  |
| Timer-Counters                  | 100  |
| Trace Size                      | 100  |
| PID Loops                       | 20   |

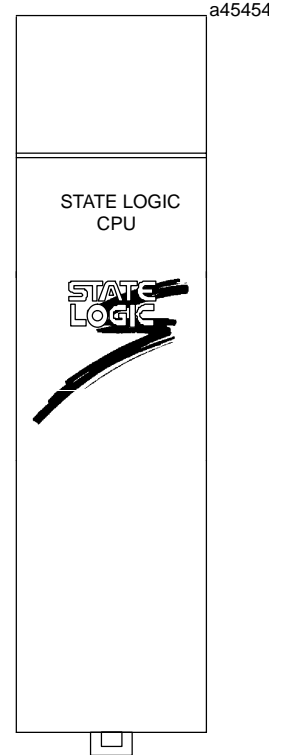

# Chapter 10

## Cables

[efesotomasyon.com](http://efesotomasyon.com)

The following table serves as a cable catalog number/application cross-reference:

Table 10-1. Series 90-30 Cable Cross-Reference

| Series 90-30 Cable Cross-Reference   |   |   |
|--|---|---|
| Catalog No.  | Description   | Applications  |
| A03B-0807-K802<br>(Equivalent to catalog number 44C741558-004)   | 33' (10 meter) I/O Link module to module cable. See publication GFK-0823 for details on I/O Link cables.  | I/O Link modules:<br>IC693BEM321 (Master)<br>IC693BEM320(Slave/Interface)   |
| A03B-0807-K803<br>(Equivalent to catalog number 44C741558-002)   | 1.5' (0.45) meter I/O Link optical adapter to module cable. See publication GFK-0823 for details on I/O Link cables.  | I/O Link modules:<br>IC693BEM321 (Master)<br>IC693BEM320(Slave/Interface)   |
| A66L-6001-009#<br>Lxxxxx<br>Note: xxxxx portion of the number depends on the cable length. Lengths are 10, 15, 20, 30, 40, 50, 60, 80, 90, and 100 meters. | I/O Link fiber optic cable, available in ten lengths. Catalog number depends on length. For example, the 10 meter cable's catalog number is A66L-6001-009#L10R03. See publication GFK-0823 for details on these length choices. | I/O Link modules:<br>IC693BEM321 (Master)<br>IC693BEM320(Slave/Interface)   |
| IC647CBL704  | Programmer serial cable to connect Work Station Interface board to the serial connector on the PLC Power Supply.  | For GE Fanuc Work Station Interface (WSI) boards:<br>IC647WMI310<br>IC647WMI320   |
| IC690ACC901<br>Miniconverter and cable kit   | Contains RS-422 to RS-232 miniconverter, a 6' (2 meter) serial cable, and a 9-pin to 25-pin adapter.  | For connecting a computer's RS-232 serial port to a PLC RS-422/485 serial port. See Appendix F for details on this product. |
| IC690CBL701<br><br>(Note: Used on older computers)   | Connects a PCM, CMM, or ADC module to a GE Fanuc Workmaster I or IBM XT or compatible personal computer.  | Use with the following modules:<br>IC693PCM300/301/311,<br>IC693CMM311<br>IC693ADC311                                       |
| IC690CBL702  | Connects a PCM, CMM, or ADC module to an IBM AT or compatible personal computer.  | Use with the following modules:<br>IC693PCM300/301/311,<br>IC693CMM311<br>IC693ADC311                                       |

|              |  |   |
|--------------|--|---|
| IC690CBL705  | Connects a PCM, CMM, or ADC module to a GE Fanuc Workmaster II or IBM PS/2 or compatible personal computer   | Use with the following modules:<br>IC693PCM300/301/311,<br>IC693CMM311<br>IC693ADC311   |
| IC690CBL714A | Dual-port multi-drop cable. Allows the interconnecting of individual PLCs using SNP serial ports. Connections are in a daisy-chain configuration.  | Series 90 PLCs.   |
| IC693CBK002  | Cable kit. Contains both the IC693CBL329 and IC693CBL330 3' (1 m) cables. Used for 32-point I/O modules having dual 24-pin connectors.   | Used with Terminal Block Quick Connect (TBQC) assemblies. See appendix J for a module list and cable selection information. See also, the data sheet for the IC693CBL329/330/331/332/333/334 cables for additional information. |
| IC693CBK003  | Cable kit. Contains both the IC693CBL331 and IC693CBL332 6' (2 m) cables. Used for 32-point I/O modules having dual 24-pin connectors.   | Used with Terminal Block Quick Connect (TBQC) assemblies. See appendix J for a module list and cable selection information. See also, the data sheet for the IC693CBL329/330/331/332/333/334 cables for additional information. |
| IC693CBK004  | Cable kit. Contains both the IC693CBL333 and IC693CBL334 19" (0.5 m) cables. Used for 32-point I/O modules having dual 24-pin connectors.  | Used with Terminal Block Quick Connect (TBQC) assemblies. See appendix J for a module list and cable selection information. See also, the data sheet for the IC693CBL329/330/331/332/333/334 cables for additional information. |
| IC693CBL300  | 3' (1 meter) I/O expansion cable interconnects baseplate expansion ports. This is a Wye type cable for daisy-chaining baseplates.  | To interconnect CPU, expansion, and remote baseplates.  |
| IC693CBL301  | 6' (2 meter) I/O expansion cable interconnects baseplate expansion ports. This is a Wye type cable for daisy-chaining baseplates.  | To interconnect CPU, expansion, and remote baseplates.  |
| IC693CBL302  | 50' (15 meter) I/O expansion cable interconnects baseplate expansion ports. This is a special type with built-in termination resistors. It is not a Wye type cable - it is for use as the last cable on the link.<br><br><b>Note:</b><br><b>This cable is identical to cable IC693CBL314</b> | To interconnect CPU, expansion, and remote baseplates.  |

|   |  |   |
|---|--|---|
| IC693CBL303   | Programmer serial cable to connect Hand-Held Programmer (HHP) to serial connector on PLC Power Supply.   | For Hand-Held Programmer:<br>IC693PRG300  |
| IC693CBL304   | Wye cable for splitting out two serial port connections from one module connector.   | For use with:<br>IC693PCM300 module   |
| IC693CBL305   | Wye cable for splitting out two serial port connections from one module connector. (Use cable IC693CBL304 with the IC693PCM300 module.)  | For use with the following modules:<br>IC693PCM301<br>IC693PCM311<br>IC693CMM311<br>IC693ADC311<br>AD693CMM301<br>IC693SLP300         |
| IC693CBL306   | 3' (1 meter) extension cable connects between the 50-pin connector on the module faceplate and the connector on the terminal block.  | For High Density (32-point) I/O modules having a single 50-pin connector:<br>IC693MDL652<br>IC693MDL653<br>IC693MDL750<br>IC693MDL751 |
| IC693CBL307   | 6' (2 meter) extension cable connects between the 50-pin connector on the module faceplate and the connector on the terminal block.  | For High Density (32-point) I/O modules having a single 50-pin connector:<br>IC693MDL652<br>IC693MDL653<br>IC693MDL750<br>IC693MDL751 |
| IC693CBL308   | 3' (1 meter) I/O cable connects to the 50-pin connector on the module faceplate. The other end has stripped, tinned, and labeled leads.  | For High Density (32-point) I/O modules having a single 50-pin connector:<br>IC693MDL652<br>IC693MDL653<br>IC693MDL750<br>IC693MDL751 |
| IC693CBL309   | 6' (2 meter) I/O cable connects to the 50-pin connector on the module faceplate. The other end has stripped, tinned, and labeled leads.  | For High Density (32-point) I/O modules having a single 50-pin connector:<br>IC693MDL652<br>IC693MDL653<br>IC693MDL750<br>IC693MDL751 |
| IC693CBL310<br><b>(Obsolete. Use IC693CBL327 and IC693CBL328)</b> | 10' (3 meter) I/O cable connects to one of the 24-pin connectors on the module. The other end has stripped, tinned, and labeled leads. This cable was obsoleted and replaced by IC693CBL315, until that cable also was obsoleted. <b>Two cables are required per module.</b> | For High Density (32-point) I/O modules having dual 24-pin connectors:<br>IC693MDL654<br>IC693MDL655<br>IC693MDL752<br>IC693MDL753    |

|   |   |  |
|---|---|--|
| IC693CBL311   | 10' (3 meter) APMI/O cable connects between one of the 24-pin connectors on the module and the connector on the terminal block.<br><b>Two cables are required per module.</b>   | APM modules:<br>IC693APU301<br>IC693APU302   |
| IC693CBL312   | 0.5' (152 mm) I/O expansion cable interconnects baseplate expansion ports. This is a Wye type cable for daisy-chaining baseplates.  | To interconnect CPU, expansion, and remote baseplates.   |
| IC693CBL313   | 26' (8 meter) I/O expansion cable interconnects baseplate expansion ports. This is a Wye type cable for daisy-chaining baseplates.  | To interconnect CPU, expansion, and remote baseplates.   |
| IC693CBL314   | 50' (15 meter) I/O expansion cable interconnects baseplate expansion ports. This is a special type with built-in termination resistors. It is not a Wye type cable - it is for use as the last cable on the link.<br><b>Note:<br/>This cable is identical to cable IC693CBL302</b>                | To interconnect CPU, expansion, and remote baseplates.   |
| IC693CBL315<br><b>(Obsolete. Use IC693CBL327 and IC693CBL328)</b> | 10' (3 meter) I/O cable connects to one of the 24-pin connectors on the module. The other end has stripped, tinned, and labeled leads.<br><b>Two cables are required per module.</b>  | For High Density (32-point) I/O modules having dual 24-pin connectors:<br>IC693MDL654<br>IC693MDL655<br>IC693MDL752<br>IC693MDL753 |
| IC693CBL316   | 3' (1 meter) serial cable with 9-pin D-shell connector that connects to a Personal Computer's serial port. The other end has an RJ-11 connector.  | For connecting to modules with an RJ-11 communications port:<br>IC693CMM321<br>IC693CPU351, 352, 363<br>IC693DSM302, 314           |
| IC693CBL317   | Special 10' (3 meter) APMI/O cable connects between one of the 24-pin connectors on the module and the connector on the terminal block. This cable is similar to IC693CBL311 except that its drain shield wire is brought outside of the connector.<br><b>Two cables are required per module.</b> | APM modules:<br>IC693APU301<br>IC693APU302s  |
| IC693CBL318   | Unused or inactive number   |  |

|   |  |  |
|---|--|--|
| IC693CBL319   | 3' (1 meter) APMI/O cable connects between one of the 24-pin connectors on the module and the connector on the terminal block.<br><b>Two cables are required per module.</b>   | APM modules:<br>IC693APU301<br>IC693APU302   |
| IC693CBL320   | Special 3' (1 meter) APMI/O cable connects between one of the 24-pin connectors on the module and the connector on the terminal block. This cable is similar to IC693CBL319 except that its drain shield wire is brought outside of the connector.<br><b>Two cables are required per module.</b> | APM modules:<br>IC693APU301<br>IC693APU302   |
| IC693CBL321<br><b>(Obsolete. Use IC693CBL329 and IC693CBL330)</b> | 3' (1 meter) I/O cable connects between a 24-pin connector on the module and the connector on the terminal block.  | Used with the Terminal Block Quick Connect assemblies. See Appendix J for a module list and cable selection information. |
| IC693CBL322<br><b>(Obsolete. Use IC693CBL331 and IC693CBL332)</b> | 6' (2 meter) I/O cable connects between a 24-pin connector on the module and the connector on the terminal block.  | Used with the Terminal Block Quick Connect assemblies. See Appendix J for a module list and cable selection information. |
| IC693CBL323<br><b>(Obsolete. Use IC693CBL333 and IC693CBL334)</b> | 1.5' (0.5 meter) I/O cable connects between a 24-pin connector on the module and the connector on the terminal block.  | Used with the Terminal Block Quick Connect assemblies. See Appendix J for a module list and cable selection information. |
| IC693CBL324   | 3' (1 meter) cable connects between a DSM module and either a servos axis terminal block or an aux axis terminal block. See the DSM user's manuals (GFK-1464, GFK-1742) for details.   | DSM modules:<br>IC693DSM302<br>IC693DSM314   |
| IC693CBL325   | 10' (3 meter) cable connects between a DSM module and either a servo axis terminal block or an aux axis terminal block. See the DSM user's manuals (GFK-1464, GFK-1742) for details.   | DSM modules:<br>IC693DSM302<br>IC693DSM314   |
| IC693CBL326   | Unused or inactive number  |  |

|             |   |  |
|-------------|---|--|
| IC693CBL327 | 10' (3 meter) right angle I/O cable connects to the left side 24-pin connector on a 32-point module. The other end has stripped, tinned, and labeled leads. <b>Replaces straight cable IC693CBL315 on the left side of the module.</b>        | For High Density (32-point) I/O modules having dual 24-pin connectors:<br>IC693MDL654<br>IC693MDL655<br>IC693MDL752<br>IC693MDL753 |
| IC693CBL328 | 10' (3 meter) right angle I/O cable connects to the right side 24-pin connector on a 32-point module. The other end has stripped, tinned, and labeled leads. <b>Replaces straight cable IC693CBL315 on the right side of the module.</b>      | For High Density (32-point) I/O modules having dual 24-pin connectors:<br>IC693MDL654<br>IC693MDL655<br>IC693MDL752<br>IC693MDL753 |
| IC693CBL329 | 3' (1 meter) right angle I/O cable connects between the left side 24-pin connector on a 32-point module and the connector on the terminal block. <b>Replaces cable IC693CBL321.</b>   | Used with the Terminal Block Quick Connect (TBQC) assemblies. See Appendix J for a module list and cable selection information.    |
| IC693CBL330 | 3' (1 meter) right angle (both connectors) I/O cable connects between the right 24-pin connector on a 32-point module or the single connector on a TBQC faceplate and the connector on the terminal block. <b>Replaces cable IC693CBL321.</b> | Used with the Terminal Block Quick Connect (TBQC) assemblies. See Appendix J for a module list and cable selection information.    |
| IC693CBL331 | 6' (2 meters) right angle (both connectors) I/O cable connects between the left 24-pin connector on a 32-point module and the connector on the terminal block. <b>Replaces cable IC693CBL322.</b>   | Used with the Terminal Block Quick Connect (TBQC) assemblies. See Appendix J for a module list and cable selection information.    |
| IC693CBL332 | 6' (2 meters) right angle I/O cable connects between the right 24-pin connector on a 32-point module or the single connector on a TBQC faceplate and the connector on the terminal block. <b>Replaces cable IC693CBL322.</b>                  | Used with the Terminal Block Quick Connect (TBQC) assemblies. See Appendix J for a module list and cable selection information.    |
| IC693CBL333 | 20" (0.5 meter) right angle I/O cable connects between the left 24-pin connector on a 32-point module and the connector on the terminal block. <b>Replaces cable IC693CBL323.</b>   | Used with the Terminal Block Quick Connect (TBQC) assemblies. See Appendix J for a module list and cable selection information.    |

|             |  |   |
|-------------|--|---|
| IC693CBL334 | 20" (0.5 meter) right angle I/O cable connects between the right 24-pin connector on a 32-point module or the single connector on a TBQC faceplate and the connector on the terminal block. <b>Replaces cable IC693CBL323.</b> | Used with the Terminal Block Quick Connect (TBQC) assemblies. See Appendix J for a module list and cable selection information.                               |
| IC693CBL340 | PTM interface cable. 19" (0.45 meter) length. Connects between PTMPM Series 90-30 PLC module and the PTMIM DIN-rail mounted interface module.  | Part of IC693PTM100 assembly. This assembly includes PTMPM module, PTMIM interface module, and IC693CBL340 cable. This cable also available as separate item. |
| IC693CBL341 | PTM interface cable. 39" (1 meter) length. Connects between PTMPM Series 90-30 PLC module and the PTMIM DIN-rail mounted interface module.   | Part of IC693PTM101 assembly. This assembly includes PTMPM module, PTMIM interface module, and IC693CBL341 cable. This cable also available as separate item. |
| IC693CBL803 | 3' (1 meter) redundant communications cable.   |   |
| IC800CBL001 | 3' (1 meter) Digital Servo Command cable connects between a DSM module and either a digital servo amplifier or a digital servo axis terminal block. See the DSM user's manuals (GFK-1464, GFK-1742) for details.               | Used with DSM modules:<br>IC693DSM302<br>IC693DSM314  |
| IC800CBL002 | 10' (3 meter) Digital Servo Command cable connects between a DSM module and either a digital servo amplifier or a digital servo axis terminal block. See the DSM user's manuals (GFK-1464, GFK-1742) for details.              | Used with DSM modules:<br>IC693DSM302<br>IC693DSM314d   |

## Cable Data Sheets

The next section of this chapter contains cable data sheets. These are listed in numerical order by catalog number, where possible. However, some data sheets cover more than one catalog number, so some catalog numbers may be out of order.

Cable data sheets are listed in this order:

| Cable Data Sheet Catalog Numbers | Description  |
|----------------------------------|--|
| IC647CBL704                      | Workstation Interface board to Series 90 CPU   |
| IC690CBL701                      | PCM to Workmaster (IBM PC-XT)  |
| IC690CBL702                      | PCM to IBM PC-AT   |
| IC690CBL705                      | PCM to Workmaster II (IBM PS/2)  |
| IC690CBL714                      | Series 90 Multidrop  |
| IC693CBL300/301/302/312/313/314  | I/O Bus Expansion cables, continuous shield. This data sheet also includes information on building custom length I/O Bus Expansion Cables. |
| IC693CBL303                      | Hand-Held Programmer cable, 6 feet (2 meters)  |
| IC693CBL304/305                  | WYE cables - Port expansion cables used with PCM 300, PCM301, PCM311, and CMM311   |
| IC693CBL306/307                  | Extension cables for 50-pin connectors on high-density I/O modules   |
| IC693CBL308/309                  | I/O Interface cables for 50-pin connectors on high-density I/O modules   |
| IC693CBL310                      | I/O Interface cable for 24-pin connectors on high-density I/O modules, 10 ft. (3 m). Obsolete.   |
| IC693CBL311/317/319/320          | I/O Interface cables for 24-pin connectors on APU301/302   |
| IC693CBL315                      | I/O Interface cable for 24-pin connectors on high-density I/O modules, 10 ft. (3 m). Obsolete.   |
| IC693CBL316                      | "Station Manager Cable." Serial cable, 3-feet long, with 9-pin D-shell to 6-pin RJ-11 connectors.  |
| IC693CBL321/322/323              | I/O straight connector cables, faceplate to terminal block, 24-pins. Obsolete.   |
| IC693CBL327/328                  | I/O right angle connector cables, faceplate to stripped leads  |
| IC693CBL329/330/331/332/333/334  | I/O right angle connector, faceplate to terminal block, 24-pin. Includes information on cable kits IC693CBK002/003/004.                    |
| IC693CBL340/341                  | PTM interface cables. Connect between PTMPM module (mounts in Series 90-30 baseplate) and PTMIM board (DIN-rail mounted).                  |

# IC647CBL704

## Workstation Interface to Series 90 CPU (SNP Port) Cable

(Includes Instructions on Building Custom Length Cables)

### Function of cable

The serial Work Station Interface cable has a 15-pin D connector on one end and a 37-pin D connector on the other end. This cable connects the CPU's serial port to the Work station Interface board installed in the programming computer through an isolated shielded, twisted pair.

### Cable Specifications

|  |  |
|--|--|
| <b>Cable Length</b>  | 10 feet (3 meters)   |
| <b>Connectors</b><br><b>CPU Side</b><br><b>Programmer Side</b> | 15-pin male, D-subminiature type with M3 screws and AMP hood 207908-4, or equivalent<br>37-pin male, D-subminiature type with 4-40 screws and AMP hood 1-207908-0, or equivalent |
| <b>Hardware Kit</b>  | AMP 207871-1. Kit includes two metric screws and two screw clips.  |
| <b>Cable Type</b>  | 24 AWG (.21 mm <sup>2</sup> ), 30V computer grade. Extra flexible construction recommended for short lengths.  |

### Connecting the Cable

- Attach the 15-pin D connector to the serial connector on the PLC power supply on the CPU baseplate.
- Attach the 37-pin D connector to the 37-pin D connector on the Work Station Interface board.

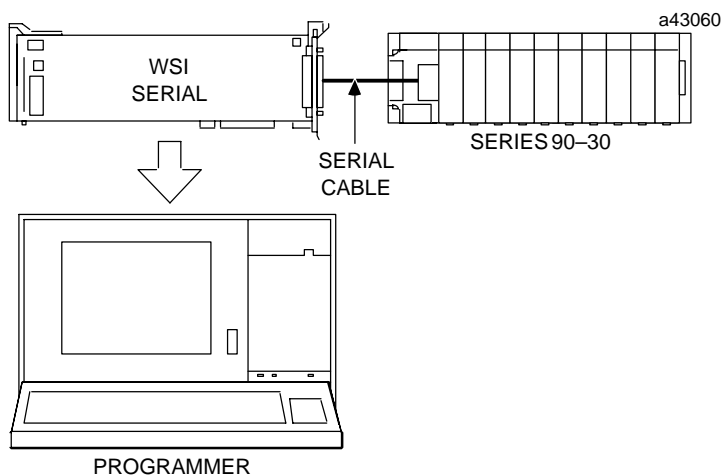

Figure 10-1. Serial Port to Work Station Interface Board Cable Connection

## Building Custom Length Cables

The following information is provided for those users who may want to build a serial cable with a different length for connecting a Series 90 PLC to a Workmaster II computer.

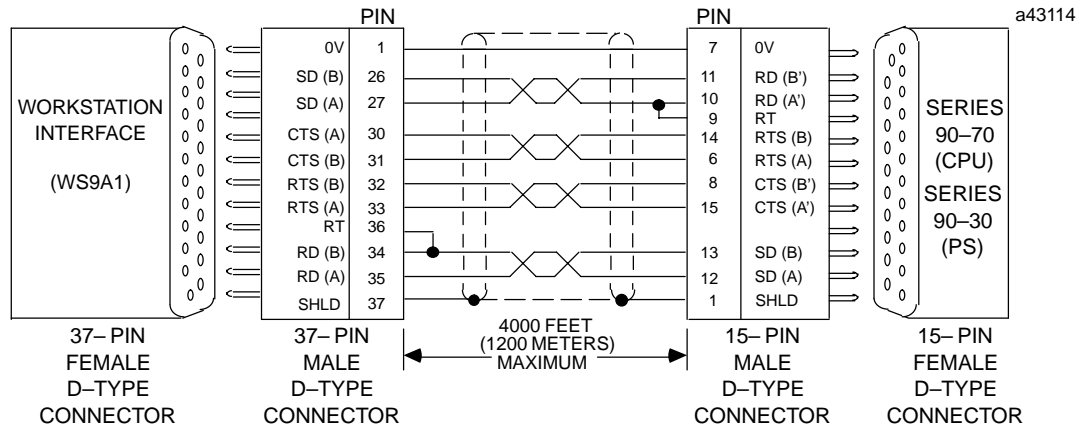

Figure 10-2. Series 90 PLC to Workmaster II Serial Cable

- Cable Type - 24 AWG (.22 mm<sup>2</sup>), 30V computer grade. Extra flexible construction recommended for short lengths.
- Connectors - 37-pin male D-type with 4-40 screws and AMP hood No. 1-207908-0 or equivalent. 15-pin male D-type with M3 screws and AMP hood No. 207908-4, or equivalent. An AMP connector is not supplied with M3 (metric) screws.
- Hardware Kit - AMP 207871-1. This kit includes two metric screws, and two screw clips.

## Multidrop Configuration, Workmaster II to Series 90 PLCs

The following illustrations show the wiring diagram and requirements for connecting a Workmaster II, Workmaster, or compatible computer to Series 90 PLCs in an 8-wire multidrop, serial data configuration.

The figure below is an example of the wiring configuration required for the multidrop configuration when using the RS-422/RS-485 to RS-232 converter.

### Note

The connector to the PLC serial port in the Series 90-30 PLC must be a right angle connector in order for the hinged door to close properly.

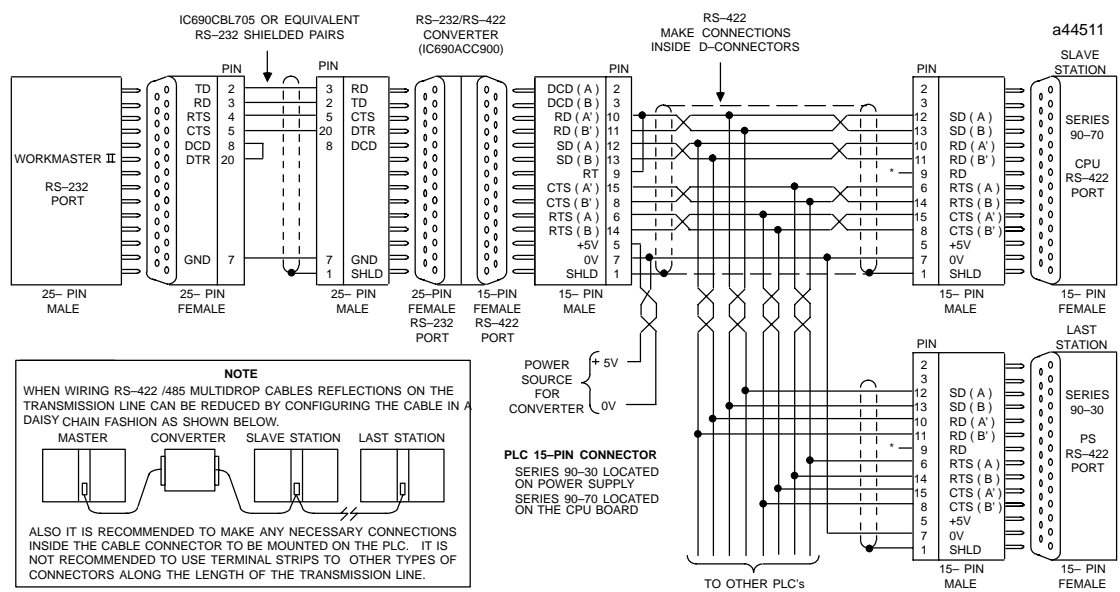

\* TERMINATION RESISTANCE FOR THE RECEIVE DATA (RD) SIGNAL NEEDS TO BE CONNECTED ONLY ON UNITS AT THE END OF THE LINES. THIS TERMINATION IS MADE ON THE SERIES 90 PLC PRODUCTS BY CONNECTING A JUMPER BETWEEN PIN 9 AND PIN 10 INSIDE THE 15-PIN D-SHELL WITH THE FOLLOWING EXCEPTION. FOR SERIES 90-70 PLCs, CATALOG NUMBERS IC697CPU731 AND IC697CPU771, THE TERMINATION FOR RD AT THE PLC IS IMPLEMENTED BY A JUMPER BETWEEN PIN 9 AND PIN 11.

GROUND POTENTIAL: MULTIPLE UNITS, NOT CONNECTED TO THE SAME POWER SOURCE, MUST HAVE COMMON GROUND POTENTIALS OR GROUND ISOLATION FOR PROPER OPERATION OF THIS SYSTEM.

Figure 10-3. Example of Multidrop Configuration with Converter

The following figure is an example of the wiring configuration required when a Work Station Interface board is installed in the computer. The 15-pin serial port connector for the 90-30 PLC is on the power supply; the 37-pin serial port connector for Workmaster II and Workmaster computers is on the Work Station Interface board in the programming computer. The cable type for these connections should be 24 AWG (.22 mm<sup>2</sup>), 30V computer grade. Extra flexible construction is recommended for short lengths.

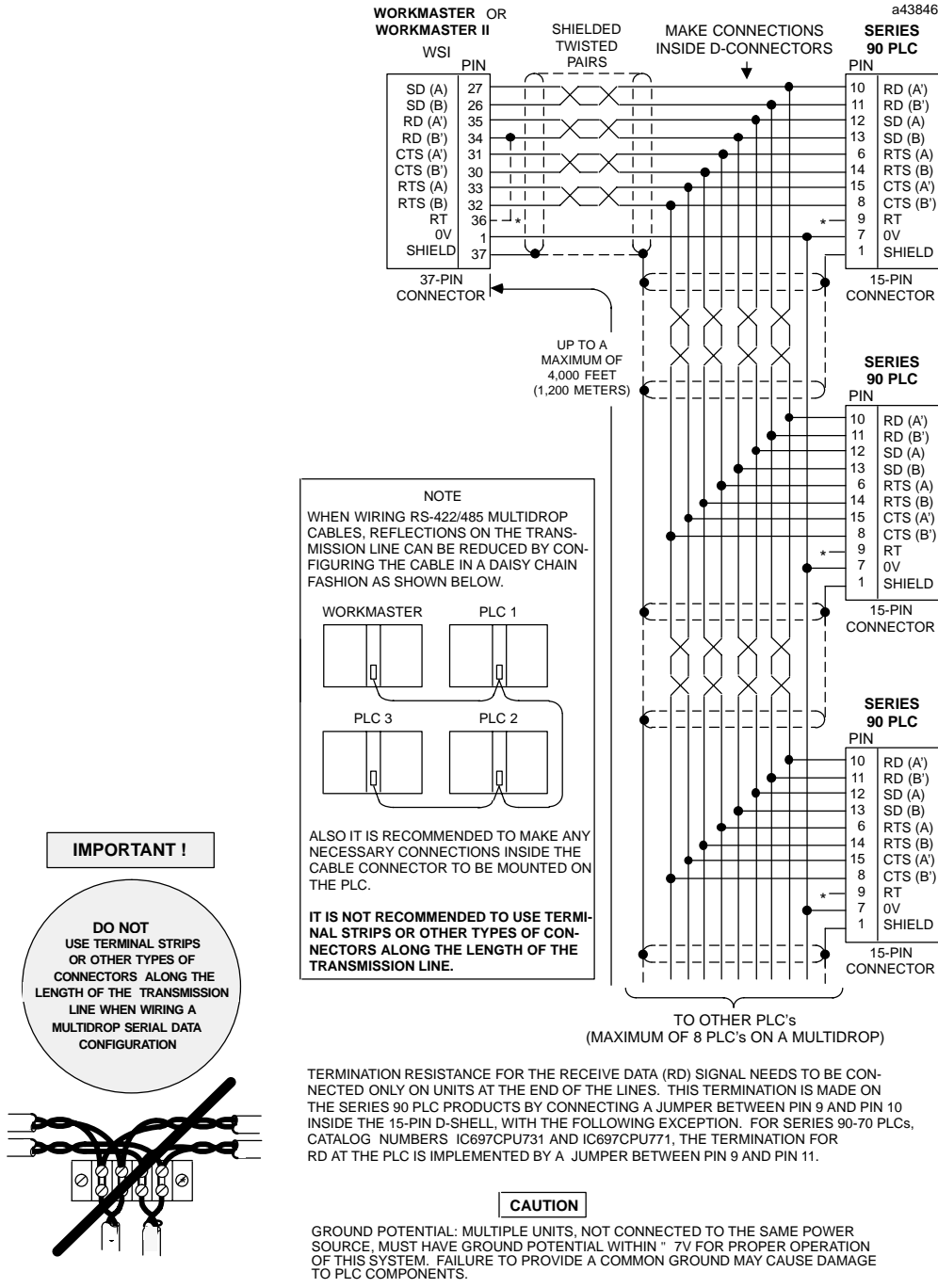

Figure 10-4. Series 90 PLC to Programmer 8-Wire Multidrop, Serial Data Configuration

# IC690CBL701

## PCM, ADC, CMM to Workmaster (PC-XT) Cable

**NOTE: This cable was designed for use with older computers such as PC or XT types and would not likely be used for new projects.**

### Function of cable

This cable provides RS-232 signal connections between the RS-232 port on a PCM, ADC, or CMM module and a serial port on a Workmaster computer or IBM-XT or equivalent Personal Computer.

### Cable Specifications

|  |   |
|--|---|
| <b>Cable Length</b>  | 10 feet (3 meters)  |
| <b>Connectors</b><br><b>PCM/ADC/CMM Side</b><br><b>Programmer Side</b> | 25-pin male, D-subminiature type, AMP 205208-1, or equivalent<br>9-pin male, D-subminiature type, AMP 205203-1, or equivalent |
| <b>Cable Clamps</b><br><b>25-pin</b><br><b>9-pin</b>                   | AMP 207908-7 or equivalent<br>AMP 207908-1 or equivalent  |
| <b>Cable Type</b>  | Six conductor, overall shield, non-paired AWG #24 (.21 mm <sup>2</sup> ), Belden 9536 or equivalent                           |

### Wiring Diagram

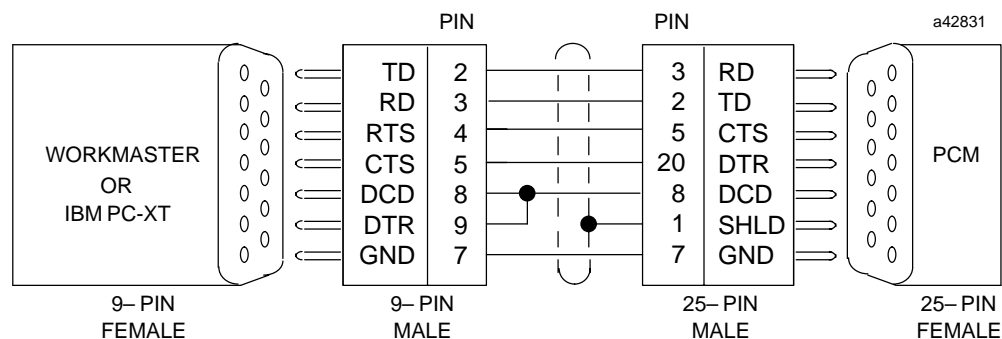

Figure 10-5. PCM, ADC, or CMM to Workmaster or PC-XT Serial Cable

### Note

Although the IC690CBL701 and 702 cables look identical (except for catalog number labeling), the internal pin connections are different.

## PCM to Programmer Cable Installation

### Caution

The Series 90-30 PLC baseplate that contains the PCM, ADC, or CMM and the programmer ground connections *must be at the same ground potential*. Incorrect wiring will result in damage to the programmer or the module.

- Select the WYE cable (IC693CBL305 or IC693CBL304).
- Connect the IC690CBL701 cable's 9-pin female connector to the male RS-232 connector (serial port) on the selected programming device.
- Connect the cable's 25-pin male connector to the Port 1 connector on the WYE cable.
- Connect the 25-pin male connector on the WYE cable to the female connector on the front of the PCM, ADC, or CMM module.

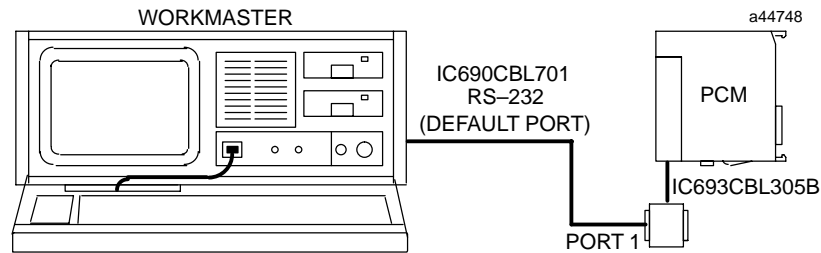

Figure 10-6. PCM to Workmaster Computer or PC-XT Personal Computer

# IC690CBL702

## PC-AT to PCM, ADC, CMM Cable

### Function of cable

This cable provides RS-232 signal connections between the RS-232 port on a PCM, ADC, or CMM module and a serial port on an IBM PC-AT or equivalent Personal Computer.

### Cable Specifications

|  |   |
|--|---|
| <b>Cable Length</b>  | 10 feet (3 meters)  |
| <b>Connectors</b><br><b>PCM/ADC/CMM Side</b><br><b>Programmer Side</b> | 25-pin male, D-subminiature type, AMP 205208-1, or equivalent<br>9-pin male, D-subminiature type, AMP 205203-1, or equivalent |
| <b>Cable Clamps</b><br><b>25-pin</b><br><b>9-pin</b>                   | AMP 207908-7 or equivalent<br>AMP 207908-1 or equivalent  |
| <b>Cable Type</b>  | Six conductor, overall shield, non-paired AWG #24 (.21 mm <sup>2</sup> ), Belden 9536 or equivalent                           |

### Wiring Diagram

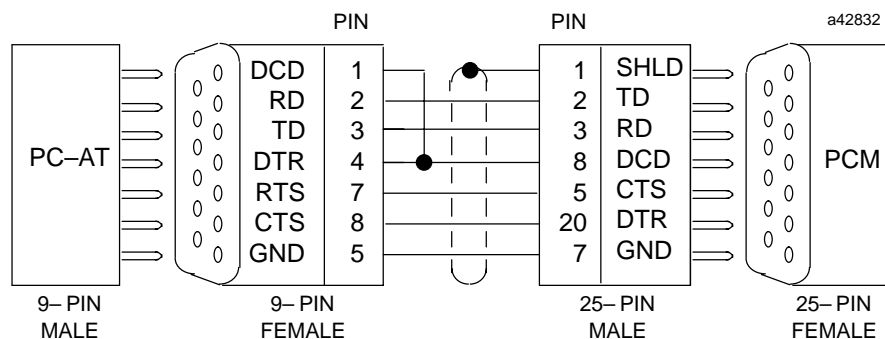

Figure 10-7. PCM, ADC, or CMM to Workmaster or PC-AT Serial Cable

### Note

Although the IC690CBL701 and 702 cables physically look identical (except for catalog number labeling), the internal pin connections are different.

## PCM to Programmer Cable Installation

### Caution

The Series 90-30 PLC baseplate that contains the PCM, ADC, or CMM and the programmer ground connections *must be at the same ground potential*. Incorrect wiring will result in damage to the programmer or the module.

- Select the WYE cable (IC693CBL305 or IC693CBL304).
- Connect the IC690CBL702 cable's 9-pin female connector to the male RS-232 connector (serial port) on the selected programming device.
- Connect the cable's 25-pin male connector to the Port 1 connector on the WYE cable.
- Connect the 25-pin male connector on the WYE cable to the female connector on the front of the PCM, ADC, or CMM module.

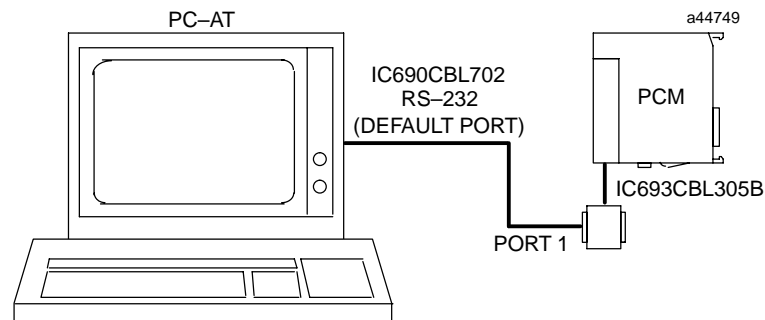

Figure 10-8. PCM to PC-AT Personal Computer

# IC690CBL705

## Workmaster II (PS/2) to PCM, ADC, CMM Cable

### Function of cable

This cable provides RTS-232 signal connections between the RS-232 port on a PCM, ADC, or CMM module and a serial port on a Workmaster II or an IBM Personal System 2 (PS/2) or equivalent Personal Computer.

### Cable Specifications

|  |  |
|--|--|
| <b>Cable Length</b>  | 10 feet (3 meters)   |
| <b>Connectors</b><br><b>PCM/ADC/CMM Side</b><br><b>Programmer Side</b> | 25-pin male, D-subminiature type, AMP 205208-1, or equivalent<br>25-pin female, D-subminiature type, AMP 205207-1, or equivalent |
| <b>Cable Clamps</b><br><b>25-pin</b>                                   | AMP 207908-7 or equivalent   |
| <b>Cable Type</b>  | Six conductor, overall shield, non-paired AWG #24 (.21 mm <sup>2</sup> ), Belden 9536 or equivalent                              |

### Wiring Diagram

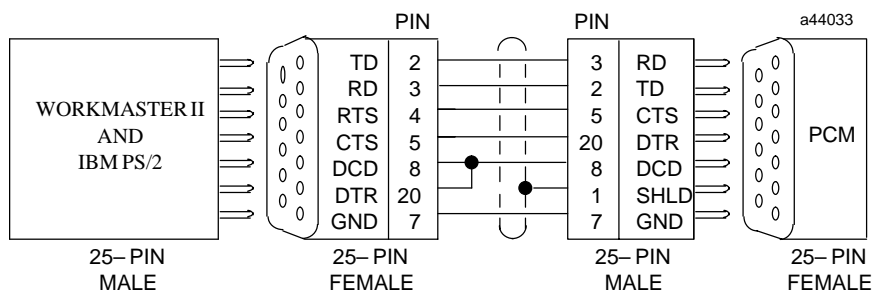

Figure 10-9. PCM, ADC, or CMM to Workmaster II or PS/2 Serial Cable

## PCM to Programmer Cable Installation

### Caution

The Series 90-30 PLC baseplate that contains the PCM, ADC, or CMM and the programmer ground connections *must be at the same ground potential*. Incorrect wiring will result in damage to the programmer or the module.

- Select the WYE cable (IC693CBL305 or IC693CBL304).
- Connect the IC690CBL705 cable's 25-pin female connector to the male RS-232 connector (serial port) on the selected programming device.
- Connect the cable's 25-pin male connector to the Port 1 connector on the WYE cable.
- Connect the 25-pin male connector on the WYE cable to the female connector on the front of the PCM, ADC, or CMM module.

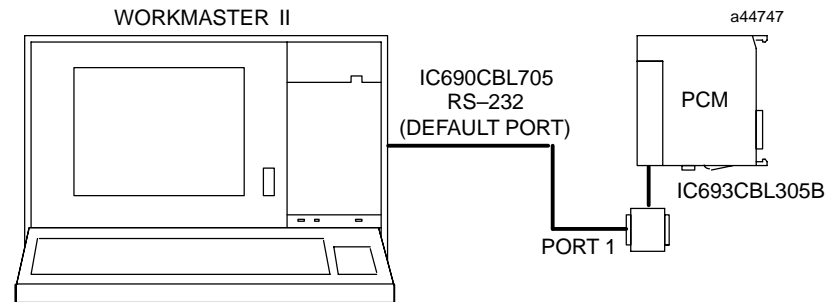

Figure 10-10. PCM to Workmaster II Computer or PS/2 Computer

# IC690CBL714A Multidrop Cable

## Purpose

This cable has a number of possible applications with Series 90 products:

- To interconnect Series 90-30 PLCs or redundant Series 90-30 PLCs in a multidrop configuration.
- To interconnect a Series 90-30 PLC and APM module in a multidrop configuration with a single personal computer (programmer). This allows programming and troubleshooting both PLC and APM without moving connection cables.
- To interconnect Series 90-70 or redundant Series 90-70 PLCs in a multidrop configuration.

## Specifications

- **Connector A:** DB15F, 15-pin female connector with M3 latchblocks
- **Connectors B and C:** DB15M, 15-pin right angle, male connector with spring clips
- **Wire:** Cable consists of three individually shielded pairs of 22-gauge stranded conductors. Belden #8777 or equivalent.
- **Jumpers:** All jumpers are made of #22 AWG (UL1061) type individual wires.
- **Length:** The length from the back of Connector A to entry into Connector B is 6 inches (+/- 0.5 inch). The length from the back of Connector C to entry into Connector B is 40 inches (+/- 1.0 inch).

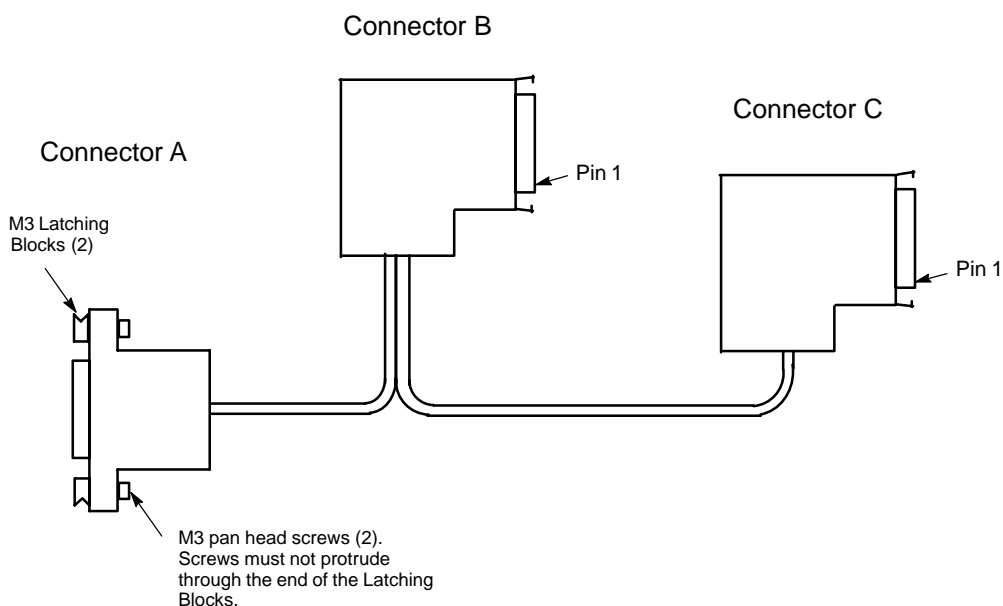

### IC690CBL714A Multi-Drop Cable Wiring Diagram

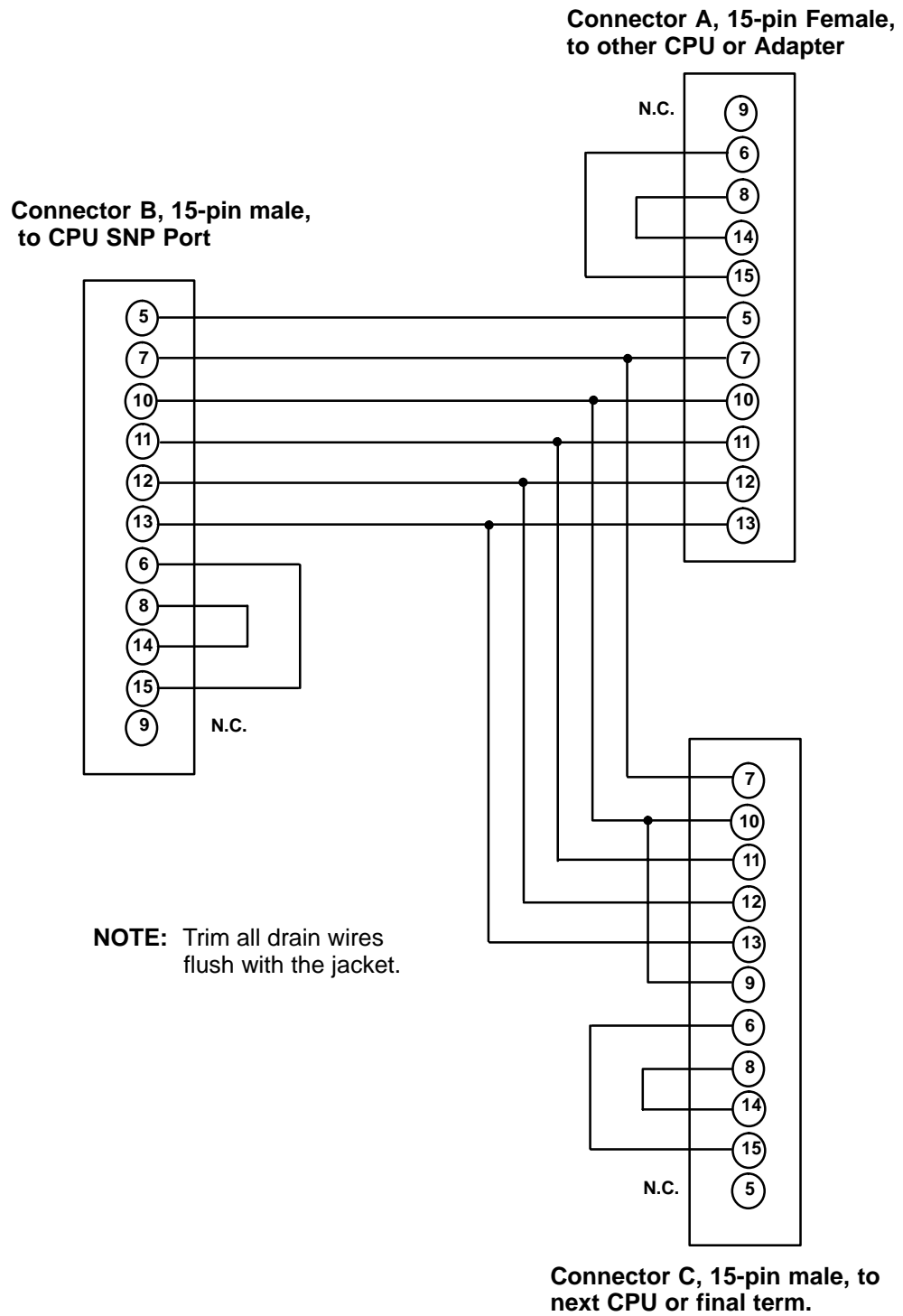

Figure 10-11. Connecting Diagram for Multidrop Cable IC690CBL714A

### Connection Diagrams for IC690CBL714A Cable

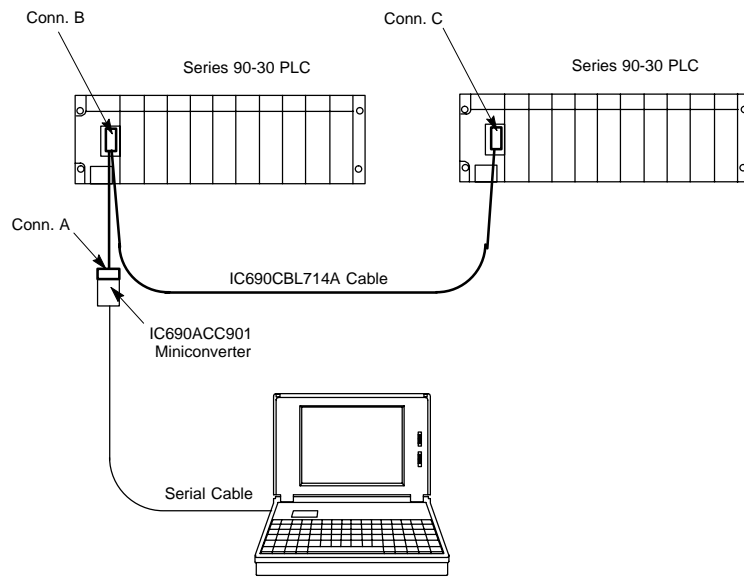

Figure 10-12. Multidrop Arrangement for Series 90-30 Redundant System

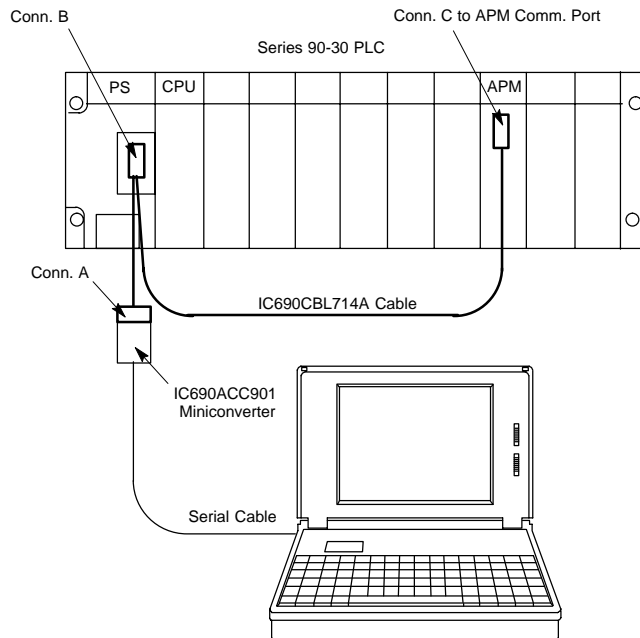

Figure 10-13. Connecting CPU and APM to Programmer with IC690CBL714A Cable

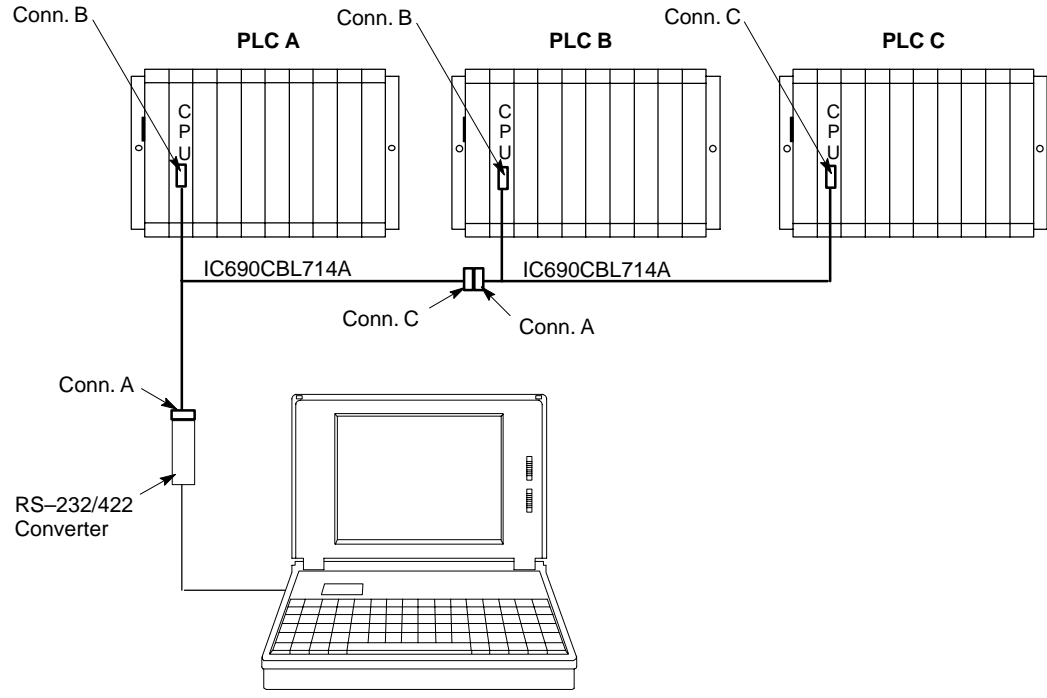

Figure 10-14. Multidrop Arrangement for Series 90-70 TMR Redundant System

# IC693CBL300/301/302/312/313/314 I/O Bus Expansion Cables

(Includes Instructions for Building Custom Length Cables)

## Description

I/O bus expansion cables (IC693CBL300, 301, 312, 313, 314), called “Wye cables,” have a single male 25-pin D connector on one end and a two-headed (one male, one female) 25-pin D connector on the other end as shown in (A) of the figure. The 50 foot (15m) (IC693CBL302) cable has a single male connector on the CPU baseplate end and a single terminated male connector on the expansion baseplate end. The 3 foot cable (IC693CBL300) can also be used as a WYE adapter cable to simplify building custom length cables (see the section “Cable Application Suggestions” later in this Chapter).

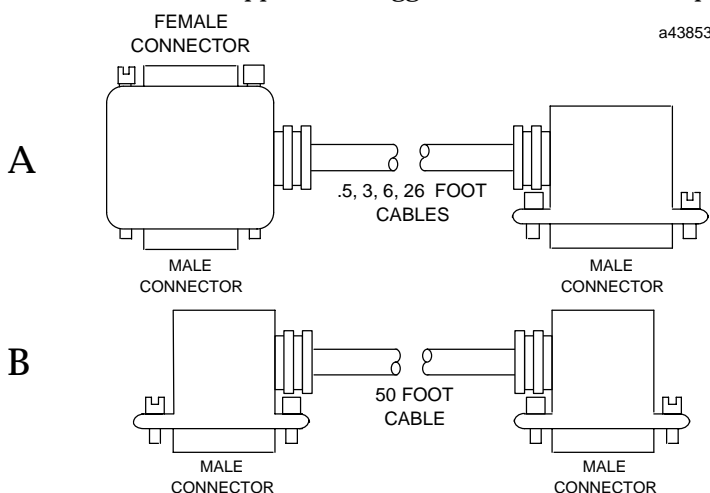

Figure 10-15. Detail of I/O Bus Expansion Cables

## Cable Lengths

- IC693CBL300 3 feet (1 meter), *continuous shield*
- IC693CBL301 6 feet (2 meters), *continuous shield*
- IC693CBL302 or IC693CBL314 50 feet (15 meters), *continuous shield*
- IC693CBL312 0.5 feet (0.15 meters), *continuous shield*
- IC693CBL313 25 feet (8 meters), *continuous shield*

## Function of Cables

The I/O Bus expansion cables are used to extend the I/O bus to expansion or remote baseplates in a Series 90-30 I/O system when additional I/O slots are needed or baseplates are required some distance from the CPU baseplate. The prewired I/O bus expansion cables can be used for connecting either expansion or remote baseplates. Where required cable length is not available in a standard cable, a custom cable must be built (see the section “Building Custom Length I/O Bus Expansion Cables” for detailed instructions).

## Connecting the Cables

- Connect the single male connector to the 25-pin female connector on the right side of the CPU baseplate.
- Connect the male connector on the dual connector end of the cable to the 25-pin female connector on the first expansion baseplate.
- Connect the unused 25-pin female connector on the dual connector end of the cable to either the single male connector of a second I/O bus expansion cable to continue the I/O bus expansion chain, or to an I/O bus Terminator plug if this is the last cable in the expansion chain.

## Important Notes About I/O Bus Expansion Cables

1. The maximum number of cables that can be included in an I/O expansion system is seven, and the total maximum cable length between the CPU baseplate and the last expansion baseplate is 50 feet (15 meters). The total maximum cable length between the CPU baseplate and the last remote baseplate is 700 feet (213 meters). Failure to observe these maximum cable lengths could result in erratic operation of the PLC system.
2. CPUs 350 – 364 support a maximum of seven I/O expansion cables. CPUs 331 – 341 support a maximum of four I/O expansion cables.
3. The 50 foot (15 meter) I/O bus expansion cable (IC693CBL302), which has a male connector on each end, has the I/O bus terminating resistors built into the end connector on the cable. If this cable is used, *you would not install a separate terminator block.*

### Caution

**I/O Bus Expansion cables should NOT be connected or disconnected with power applied to the I/O expansion baseplate(s). Unexpected PLC operation may result.**

## Cable Application Suggestions

In general, it is advantageous to use standard, factory-built cables, where possible, to save time and avoid wiring errors.

### Using Standard Cables

- For connecting between baseplates (either between a CPU and expansion baseplate, between two expansion baseplates or between two remote baseplates) in the same cabinet when a standard length (0.5, 1, 2, 8, or 15 meters) will fit the need.
- As a Wye jumper for custom built point-to-point cables (IC693CBL300 is often used for this). This combination saves time since a point-to-point cable can be built much faster than a Wye cable. An example of this is shown in Figure 10-23.

### Using Custom Built cables

- When you need a cable length not available in a standard size.
- When a cable must be routed through a conduit that is not large enough for a standard cable's connector to fit through.

## Building Custom Length I/O Bus Expansion Cables

This section provides details needed to create custom length I/O Bus Expansion cables.

### Two Types of Custom Built Cables

The two types are:

- **Point-to-Point** – these have a single male connector on one end and a single female connector on the other end. These are usually used with the IC693CBL300 which supplies the Wye connection. This combination saves time since a point-to-point cable can be built much faster than a Wye cable.
- **Wye** - these have a single male connector on one end and two connectors (one male and one female) on the other end.

### Components Needed to Build Custom Length I/O Bus Expansion Cables

Note: the special two-headed Wye connector used on the standard Wye cables is not available as a separate component.

| Item                            | Description   |
|---------------------------------|---|
| <b>Cable:</b>                   | <b>Belden8107 only (no substitutes):</b><br>Computer cable, overall braid over foil shield, twisted-pair<br>30volt/80°C (176°F)<br>24 AWG (.22 mm <sup>2</sup> ) tinned copper, 7 x 32 stranding<br>Velocity of propagation = 70% †<br>Nominal impedance = 100Ω |
| <b>25 Pin Male Connector:</b>   | Crimp Plug = Amp 207464-1; Pin = Amp 66506-9<br>Solder Plug = Amp 747912-2  |
| <b>25 Pin Female Connector:</b> | Crimp Receptacle = Amp 207463-2; Pin = Amp 66504-9<br>Solder Receptacle = Amp 747913-2  |
| <b>Connector Shell:</b>         | Kit - Amp 745833-5:<br>Metal-plated plastic (plastic with nickel over copper) †<br>Crimp ring - Amp 745508-1, split ring ferrule  |

† = Critical Information

‡ Vendor part numbers listed for user assembled cables are provided for reference only and do not suggest or imply that they are preferred. Any part meeting the same specification can be used.

## Expansion Port Pin Assignments

The following table lists the expansion port pin assignments you will need when building remote cables. All connections between cables are point-to-point, that is, pin 2 of one end to pin 2 of the opposite end, pin 3 to pin 3, etc.

Table 10-2. Expansion Port Pin Assignments

| Pin Number | Signal Name | Function                      |
|------------|-------------|-------------------------------|
| 16         | DIODT       | I/O Serial Data Positive      |
| 17         | DIODT/      | I/O Serial Data Negative      |
| 24         | DIOCLK      | I/O Serial Clock Positive     |
| 25         | DIOCLK/     | I/O Serial Clock Negative     |
| 20         | DRSEL       | Remote Select Positive        |
| 21         | DRSEL/      | Remote Select Negative        |
| 12         | DRPERR      | Parity Error Positive         |
| 13         | DRPERR/     | Parity Error Negative         |
| 8          | DRMRUN      | Remote Run Positive           |
| 9          | DRMRUN/     | Remote Run Negative           |
| 2          | DFRAME      | Cycle Frame Positive          |
| 3          | DFRAME/     | Cycle Frame Negative          |
| 1          | FGND        | Frame Ground for Cable Shield |
| 7          | 0V          | Logic Ground                  |

## I/O Expansion Bus Termination

When two or more baseplates are cabled together in an expansion system, the I/O expansion bus must be properly terminated. The I/O bus *must be terminated* at the last baseplate in an expansion system. Each signal pair is terminated with 120 ohm, 1/4 watt resistors wired between the appropriate pins, as follows (see the above table, also):

pins 16 - 17; 24 - 25; 20 - 21; 12 - 13; 8 - 9; 2 - 3

The I/O bus termination can be done one of the following ways:

- By installing an *I/O Bus Terminator Plug*, catalog number IC693ACC307, on the last expansion baseplate (local expansion baseplate or remote baseplate) in the system. The Terminator Plug has a resistor pack physically mounted inside of a connector. The I/O Bus Terminator Plug is shipped with each baseplate; only the last baseplate in the expansion chain can have the I/O Bus Terminator Plug installed. Unused I/O Bus Terminator Plugs can be discarded or saved as spares.
- If an expansion system has only one expansion baseplate, the I/O bus can be terminated by installing as the last cable, the 50 foot (15 meter) I/O Expansion cable, catalog number IC693CBL302 or IC693CBL314. These cables have the termination resistors installed in the end that connects to the expansion baseplate connector.
- You can also build a custom cable with termination resistors wired to the appropriate pins for installation at the end of the bus.

## Shield Treatment

All GE Fanuc factory made cables are made with a *continuous*, or 100% shield. This means that the braided cable shield is connected to the metal shell of the connector around the entire perimeter of the connector. This provides a low impedance path to frame ground for any noise energy that is coupled onto the cable shield.

For custom length cables made per Figure 10-18, the best noise immunity is achieved when using a metallized connector cover that makes contact with the cable's braided and foil shielding and with the connector shell on the terminating end.

### Note

It is **not sufficient** to only solder the drain wire to the connector shell. It is required that the cable's shield be continuous across the entire length of the cable, including at the terminations. The figure below shows the recommended method for folding the braided shield back before inserting the cable into a metallized cover.

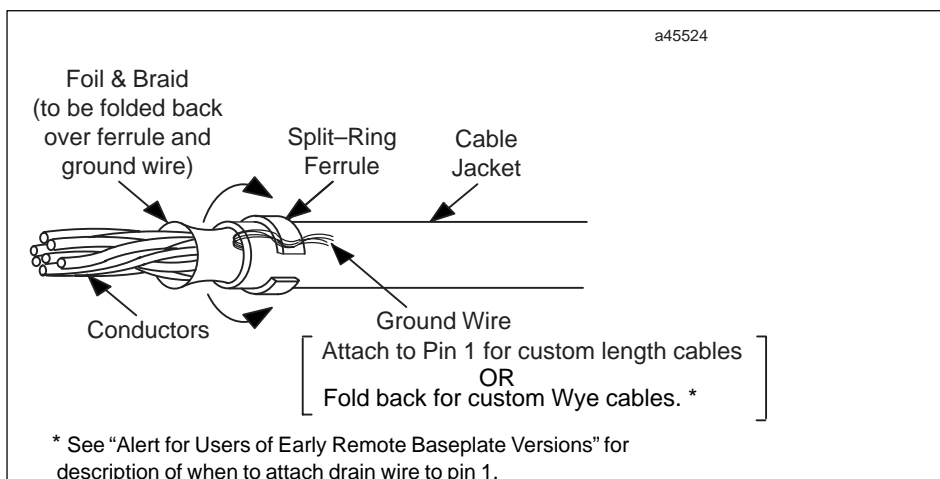

Figure 10-16. How to use Split-Ring Ferrules for Foil and Braided Cable Shield

For typical industrial applications, all expansion and remote baseplate cables can be made with plastic shell covers and should be wired as shown in Figure 10-19. In either case, pin 1 should be wired into both ends of the custom length cable and the recommendations listed below should be followed for the Wye cables treatment in the remote (IC693CHS392/399) baseplates.

When using 100% shielded cables all local (CPU and expansion) baseplates in the system must be solidly referenced to the same ground point or a potential difference between baseplates could disturb signal transmission.

## Alert for Users of Early Remote Baseplate Versions

In early remote baseplates versions, IC693CHS393E (and earlier) and IC693CHS399D (and earlier), it is necessary to remove pin 1 of the mating cable where the cable plugs into the baseplate. This means that when using a factory made Wye cable, such as IC693CBL300, you must break pin 1 out of the male end where it plugs into the remote

baseplate before using it with one of these baseplates. *Custom built Wye cables for these baseplates should be built using Figure 10-20.*

Remote baseplates IC693CHS393F (and later) and IC693CHS399E (and later) have a change inside the baseplate which eliminates the need to remove pin 1 from the mating cable. When using factory made Wye cable with these baseplates, it is **not** necessary to remove pin 1 from the cable. Custom built Wye cables for these baseplates can be made using either Figure 10-20 or Figure 10-21. Figure 10-21 shows how the standard (factory made) Wye cables are made.

By removing pin 1 in custom built Wye cables made for the earlier versions of remote baseplates, the pin 7 (0V) signal reference originates in the main (CPU) baseplate. In these earlier versions of the remote baseplates, pin 1 was tied to pin 7 (0V) and also AC coupled to the remote frame ground. When using these baseplates in combination with the 100% shielded Wye cables, the pin 7 (0V) reference would be improperly DC coupled to the remote frame ground through the D-subminiature connector shell, which is DC coupled to the remote frame ground.

In the remote baseplates IC693CHS393F (and later) and IC693CHS399E (and later), the pin 1 shield signal is DC coupled to the remote frame ground and *not* attached to pin 7 (0V). This allows the best noise immunity by providing a good continuous cable shield, and still allows the pin 7 (0V) signal reference to originate in the CPU baseplate without the need for removing pin 1 in any factory or custom built cable. The D-subminiature connector shell is still DC coupled to the remote frame ground.

### Making a 100% Shielded Cable

Use the following steps to build a 100% shielded cable:

1. Strip approximately 5/8 inch of insulation from your custom cable to expose the shield.
2. Remove the male Pin 1 from any connector plugging directly into an older version remote baseplate (IC693CHS393E, IC693CHS399D, or earlier).
3. Put split-ring ferrule over cable insulation (Figure 10-17).
4. Fold the shield back over top of the cable insulation and ferrule.
5. Place the collar of the metal hood over top of the folded shield and securely clamp the hood.
6. Test your cable for continuity between both connector shells. Connect an ohmmeter between the shells and flex the cable at both ends. If the metalized connector hood is not making proper contact with the cable shield at either end, the connection will show intermittent continuity on the ohmmeter.
7. Plug the metal hooded cable onto a remote baseplate expansion port connector or into a GE Fanuc WYE cable and securely tighten the two screws. Installing and tightening the screws will electrically connect the shield to the remote baseplate frame ground, which should in turn should be connected to earth ground as instructed in the "Installation" chapter, under the heading "Baseplate Safety Grounding."

## Wiring Diagrams

The following wiring diagrams show the wiring configuration for I/O expansion system cables. Wiring diagrams are provided for both point-to-point cables and Wye cables.

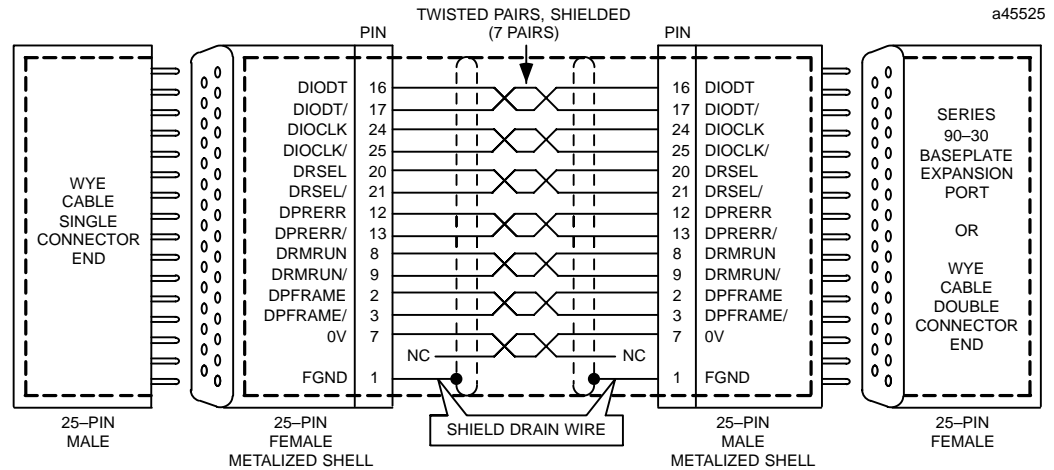

**NOTE:**  
 Bold dashed line shows continuous (100%) shielding when metallized shell connectors are plugged together.

Figure 10-17. Point-To-Point Cable Wiring for Continuous Shield Custom Length Cables

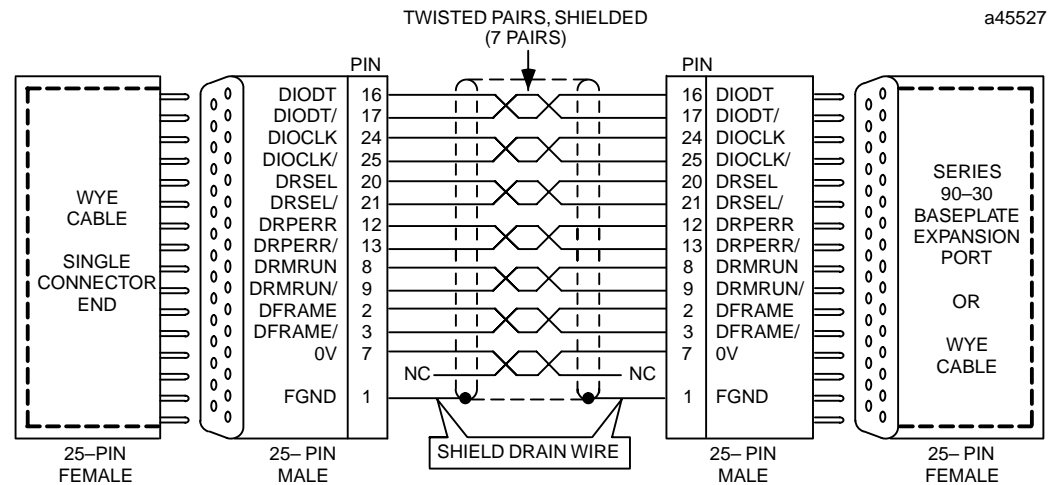
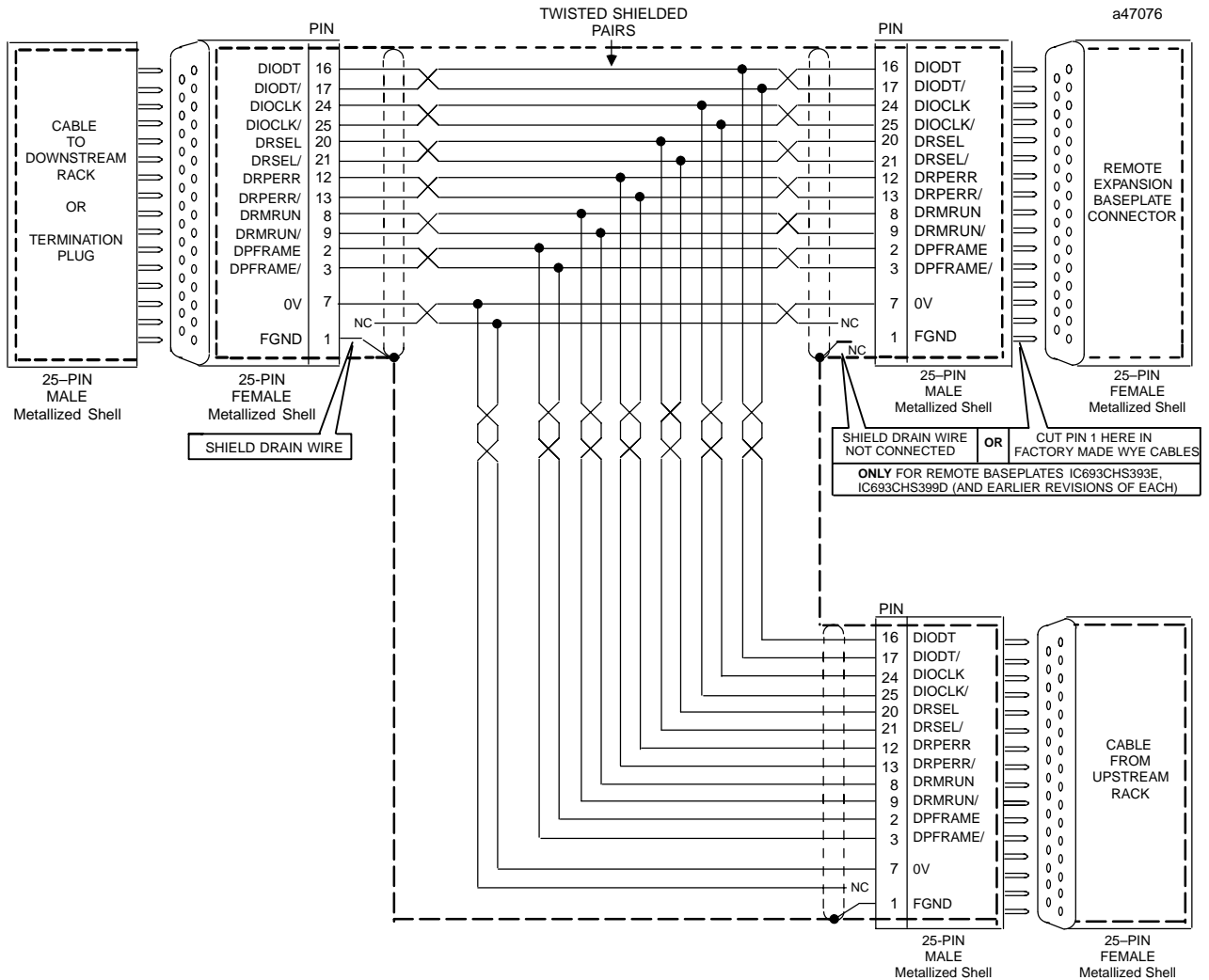

Figure 10-18. Point-To-Point Cable Wiring Diagram for Applications Requiring Less Noise Immunity



**NOTE:**  
 Bold dashed line shows continuous (100%) shielding when metallized shell connectors are plugged together.

Figure 10-19. Earlier Versions of Remote Baseplate Custom WYE Cable Wiring Diagram

**Note**

In remote baseplates, IC693CHS393E (and earlier) and IC693CHS399D (and earlier), it is necessary to remove pin 1 of the mating cable where the cable plugs into the baseplate. This means that when using a factory made Wye cable, IC693CBL300, you must break pin 1 out of the male end where it plugs into the remote baseplate before using it with one of these baseplates. *Custom built Wye cables for these baseplates should be built using Figure 10-20.* See the section "Alert to Users of Early Remote Baseplate Versions" for more details.

Remote baseplates IC693CHS393F (and later( and IC693CHS399E (and later) have a change inside the baseplate which alleviates the need to remove pin 1 from the mating cable. When using factory made Wye cable with these baseplates, it is **not** necessary to remove pin 1 from the cable. Custom built Wye cables for these baseplates can be made using either Figure 10-20 or Figure 10-21. Figure 10-21 shows how the factory made Wye cable are made.

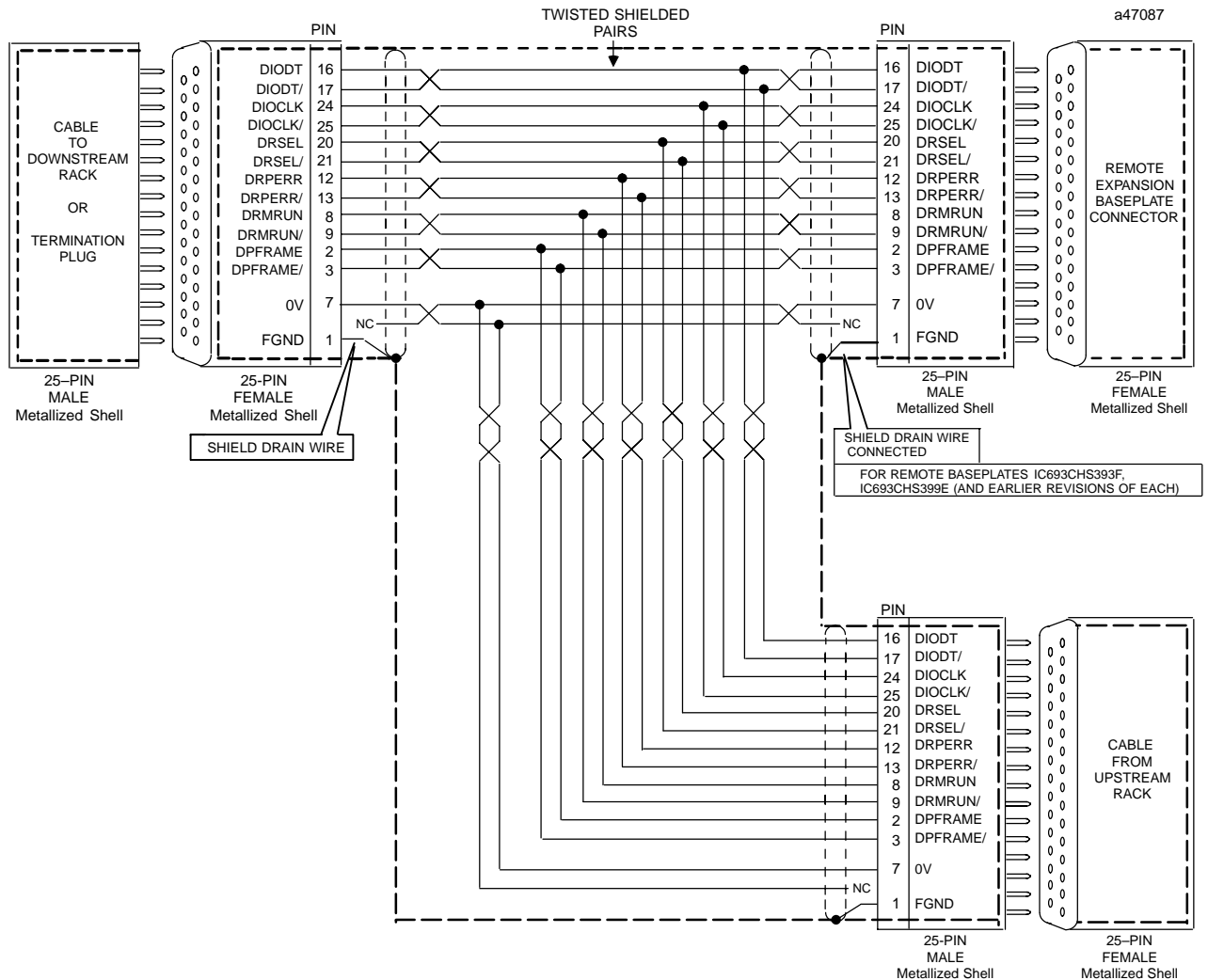

**NOTE:**  
 Bold dashed line shows continuous (100%) shielding when metallized shell connectors are plugged together.

Figure 10-20. Current Remote baseplate (IC693CHS393/399) Custom Wye Cable Wiring Diagram

## Application Examples

### Expansion System Cable Connections

The following example shows cable connections in a system that has expansion baseplates but no remote baseplates.

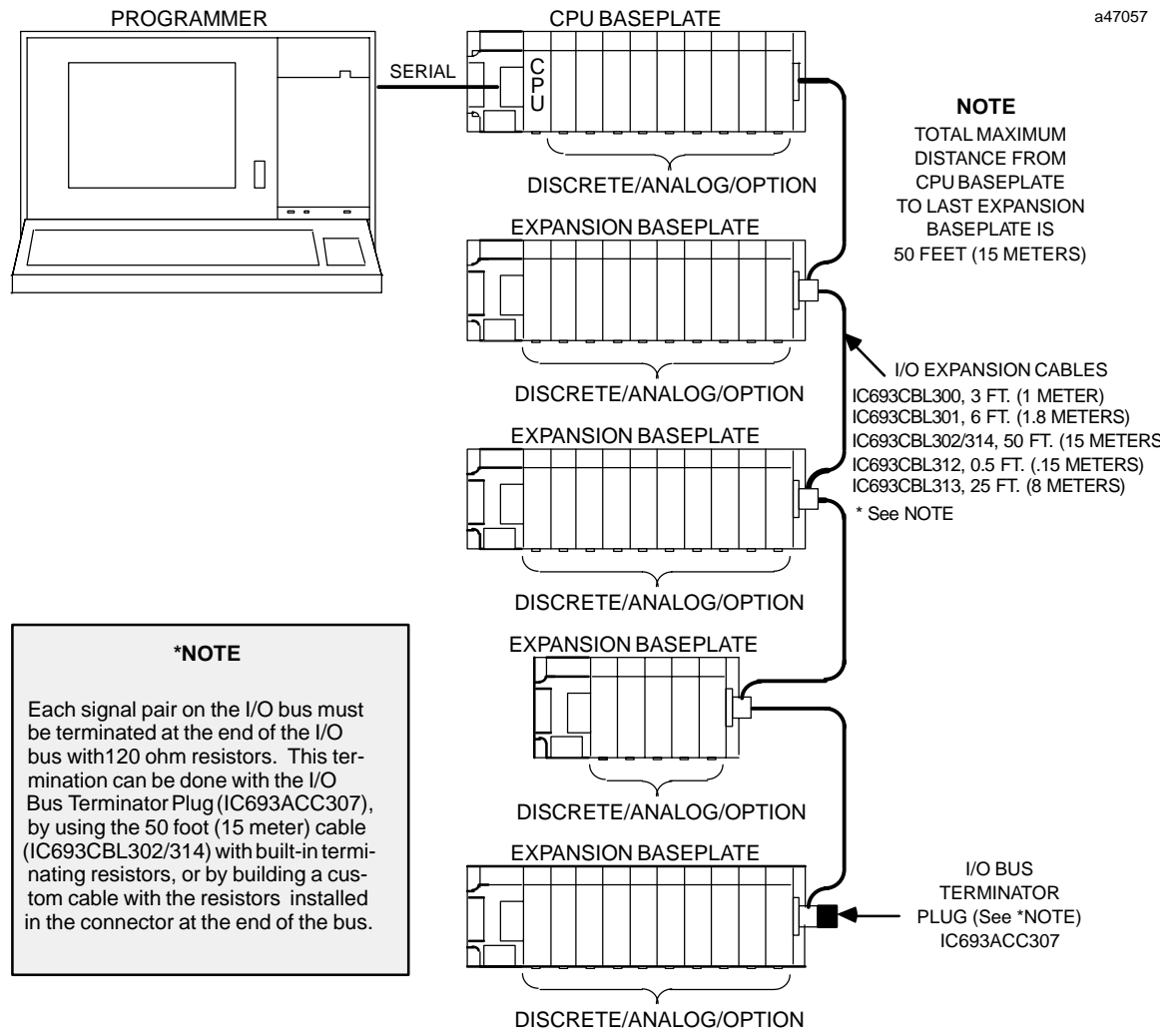

Figure 10-21. Example of Connecting Expansion Baseplates

### Remote and Expansion System Cable Connection Example

The following example shows cable connections in a system that includes both remote and expansion baseplates. A system can have a combination of remote and expansion baseplates as long as the distance and cable requirements are followed.

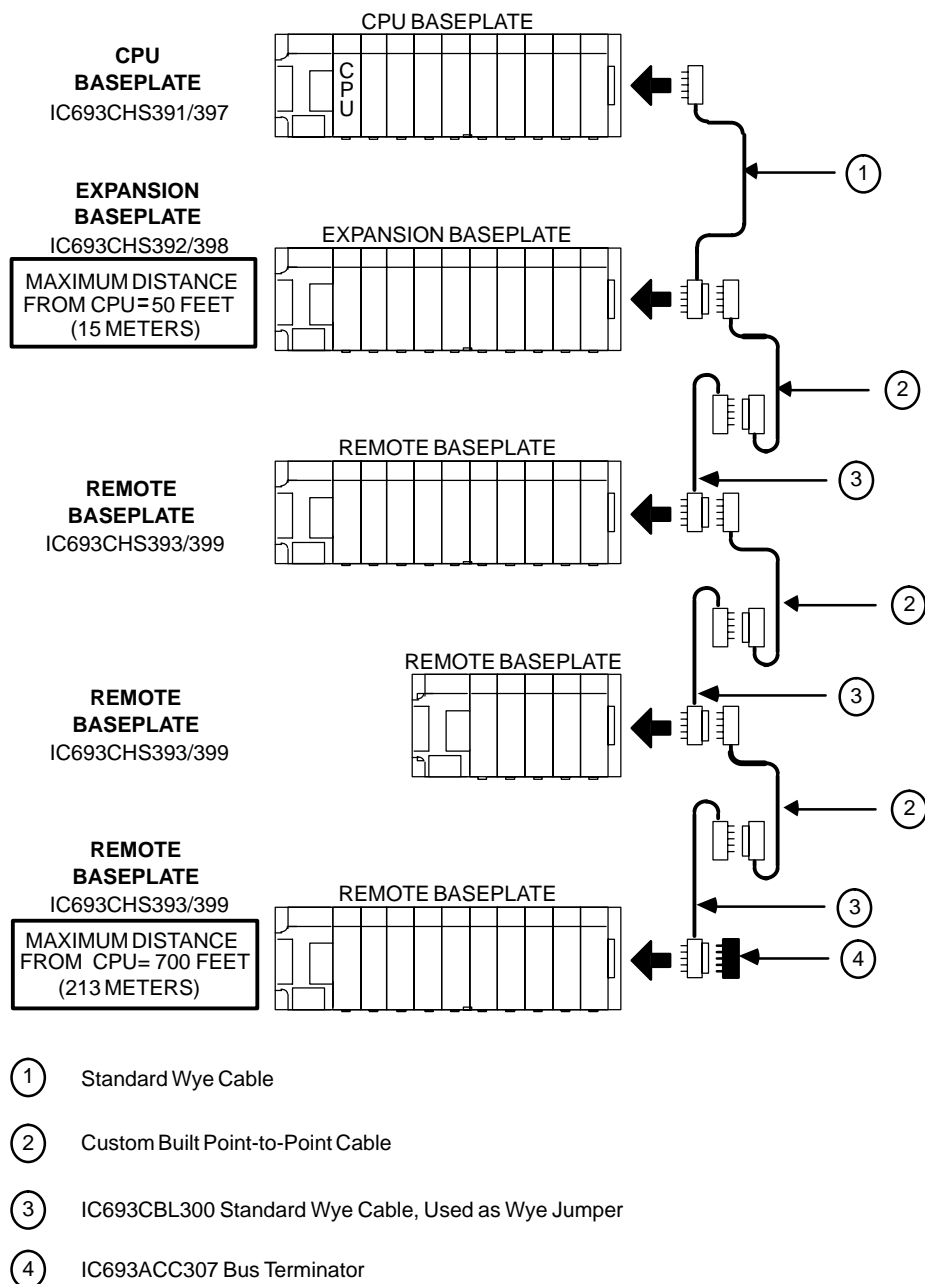

Figure 10-22. Example of Connecting Expansion and Remote Baseplates

## IC693CBL303 Hand-Hand Programmer and Converter (IC690ACC900) Cable

### Function of cable

The Hand-Held Programmer cable provides the connections that allow the Hand-Held Programmer and the Programmable Logic Controller to communicate. This cable also provides the power connections for the HHP, and a signal which indicates to the PLC that the HHP is attached to the PLC serial port. It can also be used to connect the RS-485 serial port on the PLC to the RS-422/RS-485 to RS-232 converter (IC690ACC900).

### Cable Specifications

The prewired cable (IC693CBL303) is 6 feet (2 meters) long. If a different length cable is required for connection to the converter, refer to the information below for specifications and wiring information.

This information is essential if you intend to build your own cable. The recommended cable types for this cable are listed below and depend on the length of the cable.

#### *Specifications for IC693CBL303 Prewired cable*

| Item  | Description   |
|---|---|
| <b>Connectors</b><br>Same connector is on both ends | 15-pin male, D-Subminiature Type, Canon DA15S (solder pot)  |
| <b>Hood</b>   | AMP 207470-1 connector shell                                |
| <b>Hardware kit</b>                                 | AMP 207871-1 Kit includes 2 metric screws and 2 screw clips |
| <b>Cable Type</b>                                   | Belden 9508:<br>AWG #24 (.22 mm <sup>2</sup> )              |
| <b>Cable Length</b>                                 | 6 feet (2 meters)   |

#### *Wire Types for Custom Cables*

| Cable Length                      | Wire Size                 | Catalog Number   |
|-----------------------------------|---------------------------|--|
| 30 feet (10m)                     | 22 (.36 mm <sup>2</sup> ) | Belden 9309  |
| >30 (10m) feet to 980 feet (300m) | 22 (.36 mm <sup>2</sup> ) | Same as for 30 feet. In addition, the +5 VDC logic power source for the converter cannot be supplied by the PLC. It must be provided by an external power supply connected to the +5V and SG pins at the converter end of the connector. The +5V pin at the PLC connector must not be connected to the cable. The +5V and SG connections from the power supply must be isolated from its own power line ground connection. Be sure that there is no connection between the external supply and the PLC except the SG cable connection. |

1. Catalog numbers are provided as suggestions only. Any cable having the same electrical characteristics is acceptable. It is strongly recommended that you use stranded wire. Since it is sometimes hard to find a cable with the desired number of twisted pairs (the Belden 9309 has an extra pair), you may end up with a cable with extra pairs.
2. A greater cable length between the PLC and the converter increases the possibility of noise coupling into the data and converter logic power circuits within the cable. The cable should be as short as possible in noisy environments. In extreme cases, additional noise protection measures, such as double-shielded cables, may be required.

## Wiring Diagram

The following wiring diagram applies to the IC693CBL303 cable and to custom-built cables.

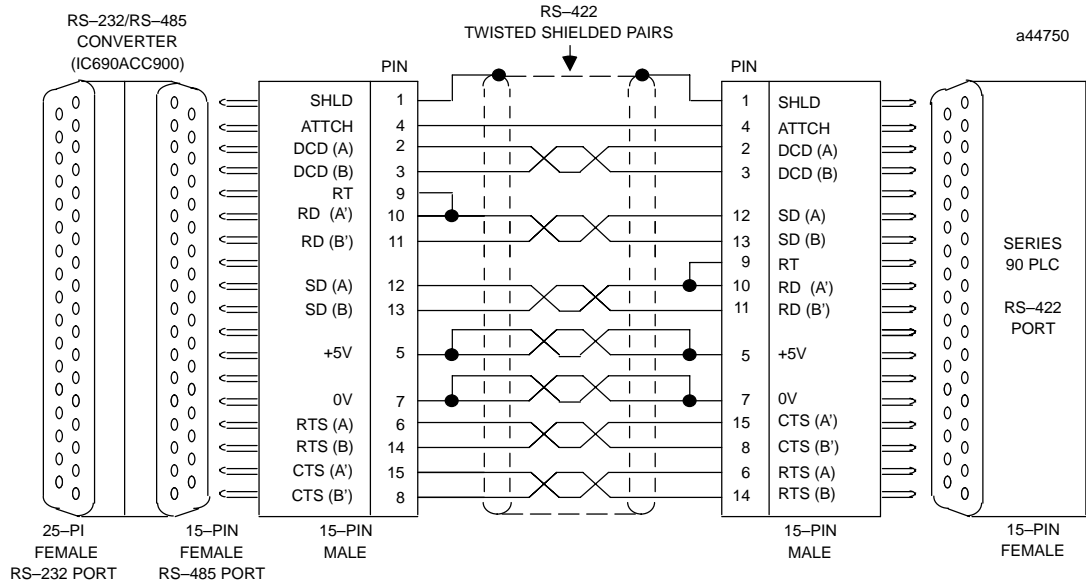

**NOTE:** PINS 9 AND 10 ARE JUMPED AT BOTH ENDS OF CABLE TO CONNECT TERMINATING RESISTORS FOR THE RD SIGNAL WHICH IS INSIDE THE PLC POWER SUPPLY.

Figure 10-23. Wiring Connections for IC693CBL303 and Custom-Built Cables

## Connecting the Cable

- Attach the 15-pin male D connector to the serial port connector on the PLC power supply.
- Attach the D connector on the other end to the mating connector on the HHP. These connections are shown in the following figure.

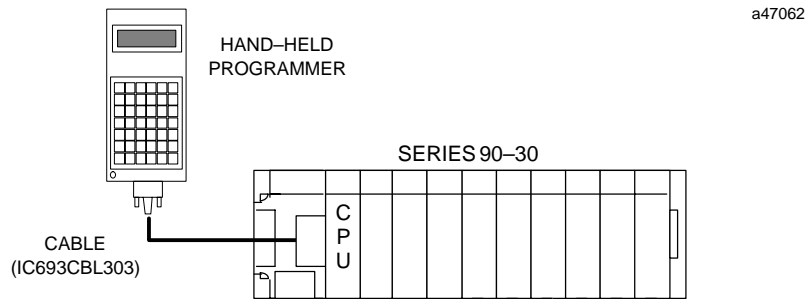

Figure 10-24. Hand-Held Programmer Cable Connection to a Series 90-30 PLC

## IC693CBL304/305

### Port Expansion (WYE) Cables for PCM, ADC, and CMM

#### Function of cable

A WYE cable (IC693CBL304 for PCM300; IC693CBL305 for PCM301/311, ADC311, CMM311, AD693CMM301, and SLP300) is supplied with each PCM, ADC, and CMM module. The WYE cable is used to separate two ports available on a single physical connector; the cable separates the RS-232 from the RS-485 signals. In addition, the WYE cable allows cables used with the Series 90-70 PCM to be fully compatible with the Series 90-30 PCM. The WYE cable and cable connections are shown below and on the following page.

Each WYE cable is 1 foot in length and has a right angle male connector on one end that connects to the PCM module. The other end has a dual female connector with one connector for port 1 and the other for port 2.

a44225

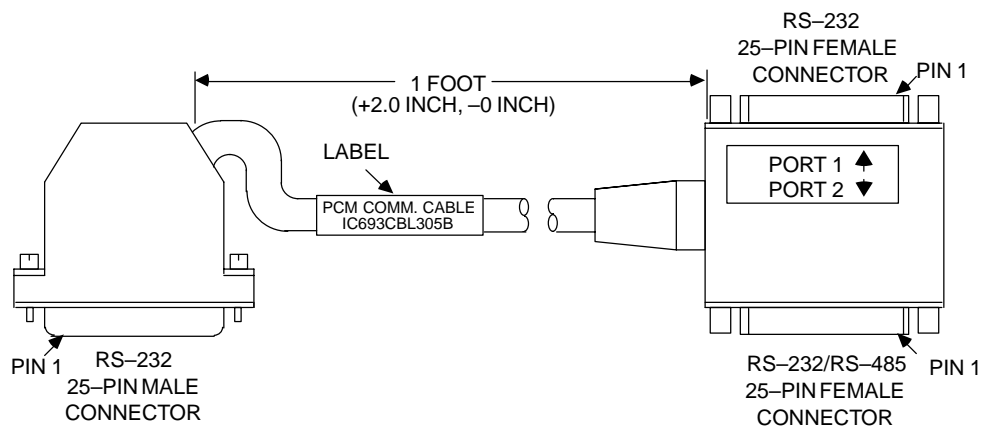

Figure 10-25. Wye Cable

#### Cable Specifications

|                                 |  |
|---------------------------------|--|
| <b>CableLength</b>              | <b>1 foot (0.3 meters)</b>   |
| <b>25 Pin Male Connector:</b>   | Crimp Plug = Amp 207464-1; Pin = Amp 66506-9<br>Solder Plug = Amp 747912-2                 |
| <b>25 Pin Female Connector:</b> | Crimp Receptacle = Amp 207463-2; Pin = Amp 66504-9<br>Solder Receptacle = Amp 747913-2     |
| <b>ConnectorShell:</b>          | Kit - Amp 207908-7<br>Separate Shell = Amp 207345-1;<br>Male Screw Retainer = Amp 205980-1 |
| <b>Cable Type</b>               | 27 conductor cable, 28 AWG (.09 mm <sup>2</sup> ), with overall shield, extra flexible     |

### Wiring Information

The following figure shows the pin configuration for each of the connectors on the WYE cable.

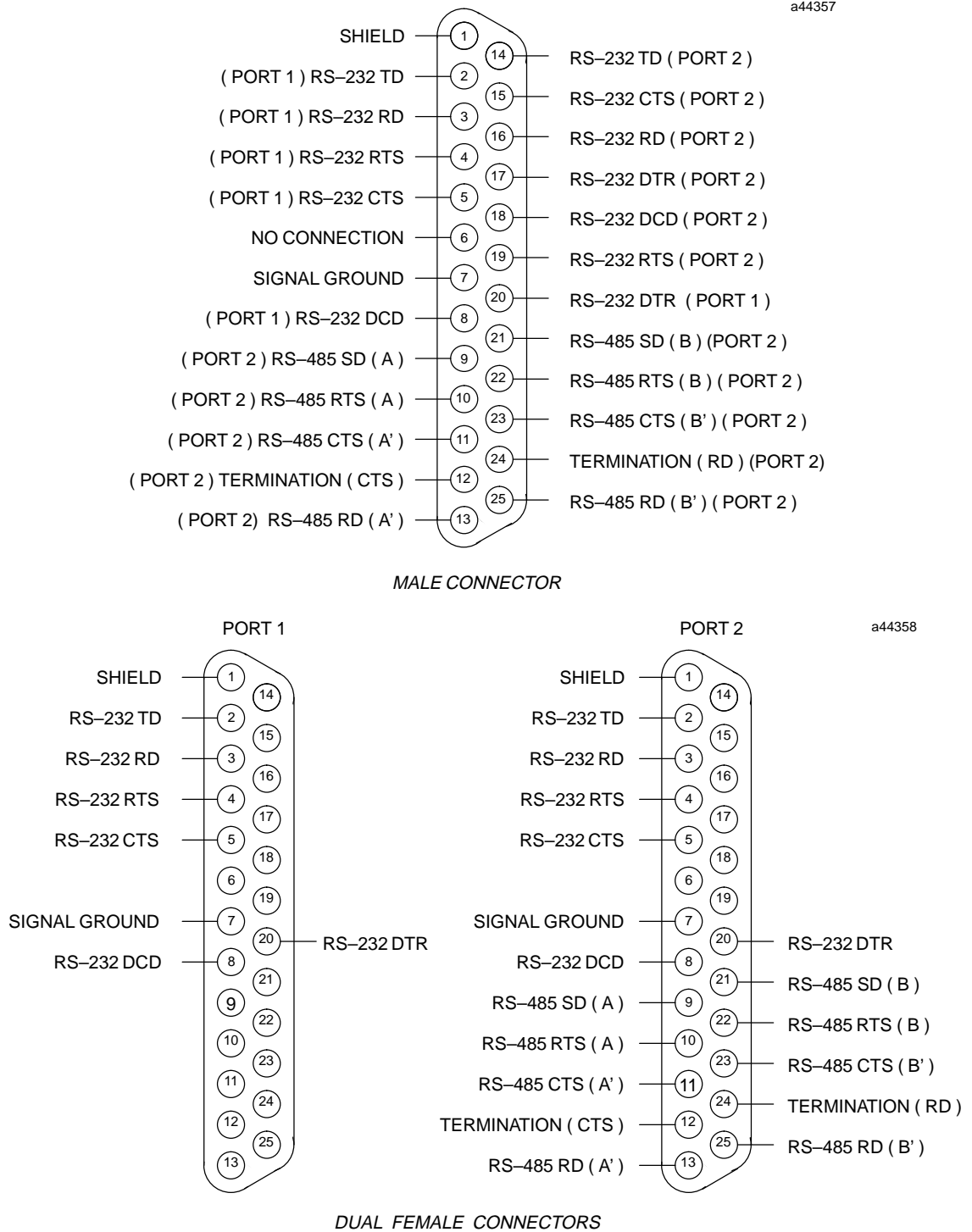

Figure 10-26. Wye Cable Connections

The WYE cable is 1 foot in length and has a right angle male connector on one end that connects to the PCM module. The other end has a dual female connector with one connector for port 1 and the other for port 2.

In order to use an RS-232 cable on port 2 of the Series 90-30 PLC, either a special cable must be made following the serial port pin assignments shown above or a WYE cable must be used. The WYE cable allows use of standard Series 90-70 cables (IC690CBL701/702/705) for the PCM or ADC. When installing the CMM module, use the WYE cable in conjunction with cables that you build for the CMM module according to directions in Chapter 8 of GFK-0582, the *Series 90 PLC Serial Communications Manual*.

# IC693CBL306/307

## Extension Cables (50-Pin) for 32 Point Modules

### Function of cable

This cable is used with 32 point High Density modules that have a 50-pin male Honda connector mounted on the front of the module. The extension cables have a 50-pin male connector on one end and a 50-pin female connector on the other end. This cable provides a connection from the module to a connector mounted on a DIN-rail-mounted terminal block assembly. This cable is wired pin-to-pin (That is, pin 1 to pin 1, pin 2 to pin 2, etc.). The modules that use these cables are: IC693MDL652, IC693MDL653, IC693MDL750, and IC693MDL751.

The connector on the module is oriented with the notch towards the top of the module with pin 1 at the top of the the right row of pins as you are looking at it, as shown below:

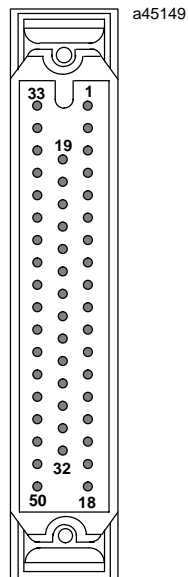

### Cable Specifications

|  |  |
|--|--|
| <b>CableLength</b><br>IC693CBL306<br>IC693CBL307 | 3 feet (1 meter),<br>6 feet (2 meters)   |
| <b>Connectors</b>                                | 50-pin female Honda on end that connects to male connector on module.<br>50-pin male connector on end that connects to Connector Interface Assembly. |

We recommend the use of a terminal block for connecting field wiring to the 50-pin high-density I/O modules. The use of a connector interface provides a convenient method of terminating field wiring to the modules.

Weidmuller Electrical and Electronic Connection Systems makes a suitable terminal block assembly RS-MR 50 B, catalog number 912263 (female Honda connector). An example of using an IC693CBL306 or 307 cable to connect a 32 point I/O module to one of these terminal blocks is shown in the following figure.

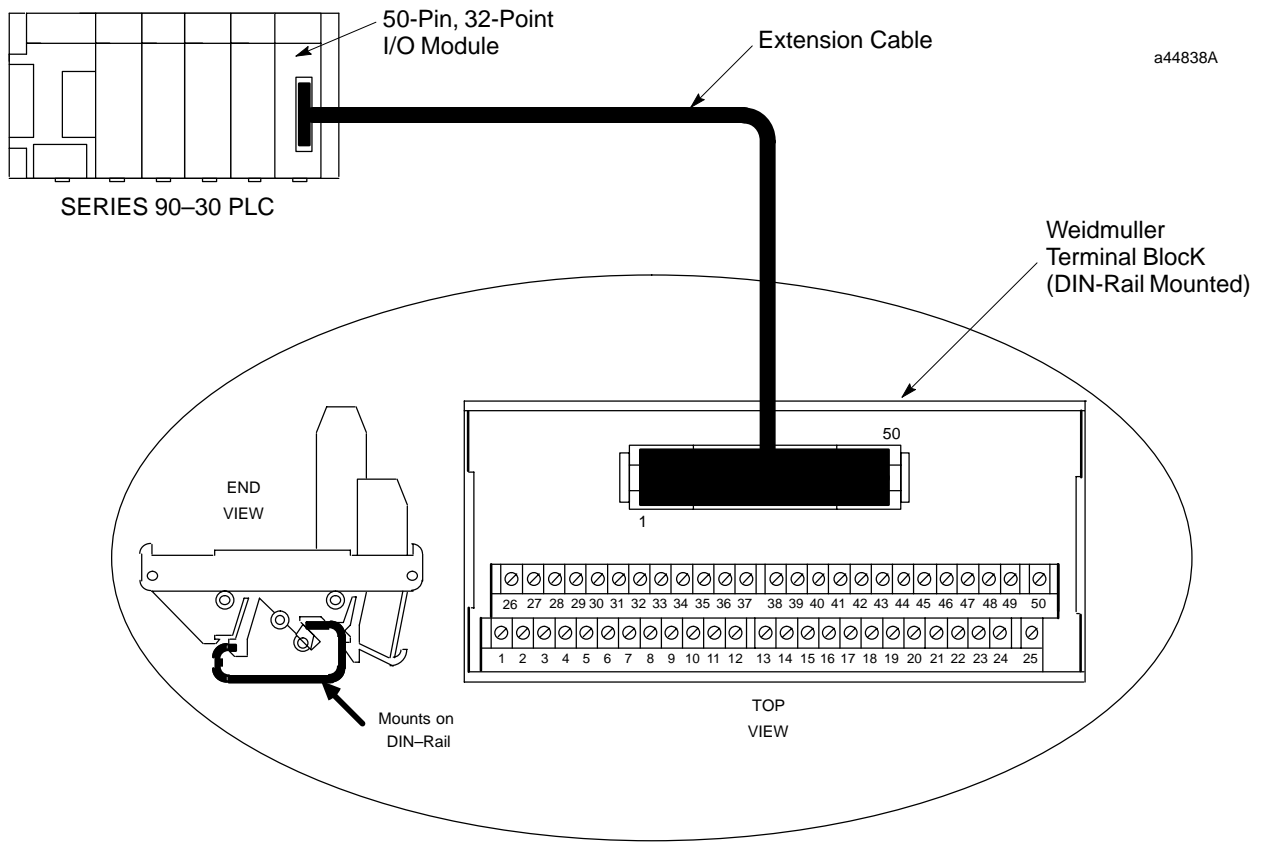

Figure 10-27. 32 Point I/O Module to Weidmuller Terminal Block Assembly

## IC693CBL308/309

### I/O Cables (50-Pin) for 32 Point Modules

#### Function of cable

This cable is used with 32 point High Density modules that have a 50-pin Honda connector mounted on the front of the module. The modules that use these cable are: IC693MDL652, IC693MDL653, IC693MDL750, and IC693MDL751.

The I/O cables have a female connector on one end, and stripped and tinned wires on the other end. Each of the stripped and tinned wires has a label attached to it for ease of identification. The numbers on these labels correspond with the pin number of the connector wired to the opposite end.

#### Specifications

|   |   |
|---|---|
| <b>Cable Length</b><br>IC693CBL308<br>IC693CBL309 | 3 feet (1 meter)<br>6 feet (2 meters)   |
| <b>Connectors</b>                                 | 50-pin female Honda on end that connects to male connector on module. Opposite end has stripped and tinned labeled wires for connection to Connector Interface Assembly |

#### Wiring Information

Table 10-3. Wire List for 32 Point I/O Cables

| Connector Pin Number | Color Code         | Label Number Loose End | Connector Pin Number | Color Code          | Label Number Loose End |
|----------------------|--------------------|------------------------|----------------------|---------------------|------------------------|
| 1                    | Black              | 1                      | 26                   | White/Black/Violet  | 26                     |
| 2                    | Brown              | 2                      | 27                   | White/Black/Gray    | 27                     |
| 3                    | Red                | 3                      | 28                   | White/Brown/Red     | 28                     |
| 4                    | Orange             | 4                      | 29                   | White/Brown/Orange  | 29                     |
| 5                    | Yellow             | 5                      | 30                   | White/Brown/Yellow  | 30                     |
| 6                    | Green              | 6                      | 31                   | White/Brown/Green   | 31                     |
| 7                    | Blue               | 7                      | 32                   | White/Brown/Blue    | 32                     |
| 8                    | Violet             | 8                      | 33                   | White/Brown/Violet  | 33                     |
| 9                    | Gray               | 9                      | 34                   | White/Brown/Gray    | 34                     |
| 10                   | White              | 10                     | 35                   | White/Red/Orange    | 35                     |
| 11                   | White/Black        | 11                     | 36                   | White/Red/Yellow    | 36                     |
| 12                   | White/Brown        | 12                     | 37                   | White/Red/Green     | 37                     |
| 13                   | White/Red          | 13                     | 38                   | White/Red/Blue      | 38                     |
| 14                   | White/Orange       | 14                     | 39                   | White/Red/Violet    | 39                     |
| 15                   | White/Yellow       | 15                     | 40                   | White/Red/Gray      | 40                     |
| 16                   | White/Green        | 16                     | 41                   | White/Orange/Yellow | 41                     |
| 17                   | White/Blue         | 17                     | 42                   | White/Orange/Green  | 42                     |
| 18                   | White/Violet       | 18                     | 43                   | White/Orange/Blue   | 43                     |
| 19                   | White/Gray         | 19                     | 44                   | White/Orange/Violet | 44                     |
| 20                   | White/Black/Brown  | 20                     | 45                   | White/Orange/Gray   | 45                     |
| 21                   | White/Black/Red    | 21                     | 46                   | White/Yellow/Green  | 46                     |
| 22                   | White/Black/Orange | 22                     | 47                   | White/Yellow/Blue   | 47                     |
| 23                   | White/Black/Yellow | 23                     | 48                   | White/Yellow/Violet | 48                     |
| 24                   | White/Black/Green  | 24                     | 49                   | White/Yellow/Gray   | 49                     |
| 25                   | White/Black/Blue   | 25                     | 50                   | White/Green/Blue    | 50                     |

# IC693CBL310

## I/O Interface Cable (24-Pin) for 32 Point Modules

Note: This cable is obsolete. Please use IC693CBL327 and IC693CBL328. See the data sheet for these cables for details. The replacement cables have right-angle connectors to reduce the clearance space required in front of the PLC.

### Function of cable

This 10' (3 meter)0 prewired cable was used with all Series 90-30 high-density (32 point) I/O modules that use the Fujitsu 24-pin user I/O connector. Each of these modules has two of these connectors mounted side-by-side. I/O Interface cables have a 24-pin female connector on one end for connection to the module, and stripped and tinned wires on the other end. Catalog numbers for 32 point modules having two 24-pin connectors are: IC693MDL654, IC693MDL655, IC693MDL752, and IC693MDL753.

Connections to module input circuits are made from the user's input devices to two male (pin-type) 24-pin connectors (Fujitsu FCN-365P024-AU) mounted on the front of the module. The connector mounted on the right of the module (front view) interfaces with groups A and B; the connector on the left side of the module interfaces with groups C and D. If a different length cable is required for connections to these modules, you can build your own cable (information on building your own cable is found in the data sheet for cable IC693CBL315).

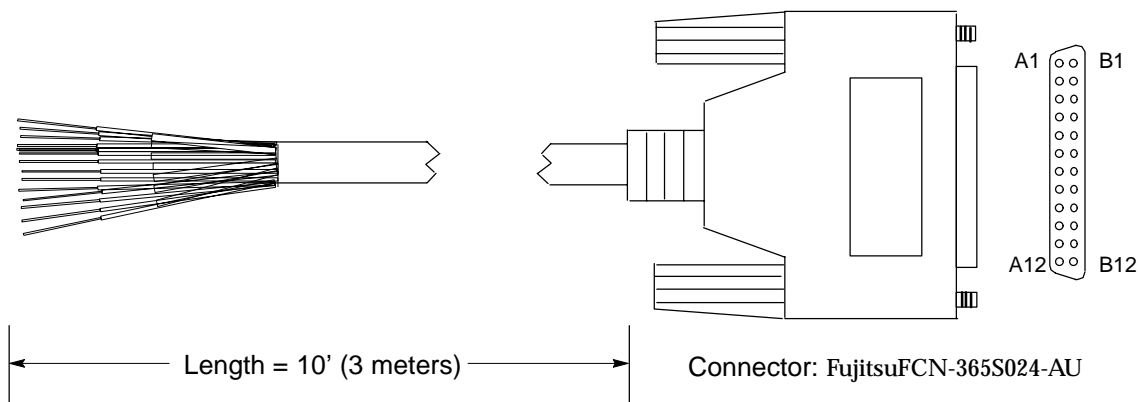
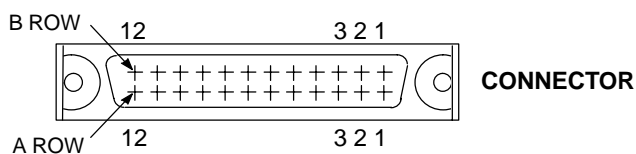

Figure 10-28. IC693CBL310 Cable

Table 10-4. Wire List for 24-Pin Connectors

| Pin Number | Pair # | Wire Color Code |
|------------|--------|-----------------|
| A1         | 1      | BLACK           |
| A2         | 1      | WHITE           |
| A3         | 2      | BROWN           |
| A4         | 2      | WHITE           |
| A5         | 3      | RED             |
| A6         | 3      | WHITE           |
| A7         | 4      | ORANGE          |
| A8         | 4      | WHITE           |
| A9         | 5      | YELLOW          |
| A10        | 5      | WHITE           |
| A11        | 6      | GREEN           |
| A12        | 6      | WHITE           |

| Pin Number | Pair # | Wire Color Code |
|------------|--------|-----------------|
| B1         | 7      | BLUE            |
| B2         | 7      | WHITE           |
| B3         | 8      | VIOLET          |
| B4         | 8      | WHITE           |
| B5         | 9      | GRAY            |
| B6         | 9      | WHITE           |
| B7         | 10     | BROWN           |
| B8         | 10     | BLACK           |
| B9         | 11     | RED             |
| B10        | 11     | BLACK           |
| B11        | 12     | ORANGE          |
| B12        | 12     | BLACK           |



**NOTE**

Each pair of wires should be tied together with heat shrink tubing for identification purposes. For example, a short piece of heat shrink tubing should be placed around the BLACK and WHITE wire pair (Pair #1) that connect to Pins A1 and A2, etc.

**Replacement/Obsolescence Information**

- This cable became obsolete and was replaced by cable IC693CBL315 (now obsolete also). The only difference between these two cables is in the wire color coding.
- When cable IC693CBL315 became obsolete, the replacement for these cables became IC693CBL327 and IC693CBL328. Cables IC693CBL310/315 have straight connectors. Cables IC693CBL327/328 have right angle connectors. The right angle connectors require less depth in front of the PLC, so allow the use of a smaller enclosure in some applications.
- Data sheets for cables IC693CBL315 and IC693CBL327/328 can be found in this chapter.

### Connector Depth for Cable IC693CBL310

The following illustration shows the space required in front of the PLC when this cable is connected to a module. The depth of the cabinet that the PLC is mounted in should allow for the depth added by this connector.

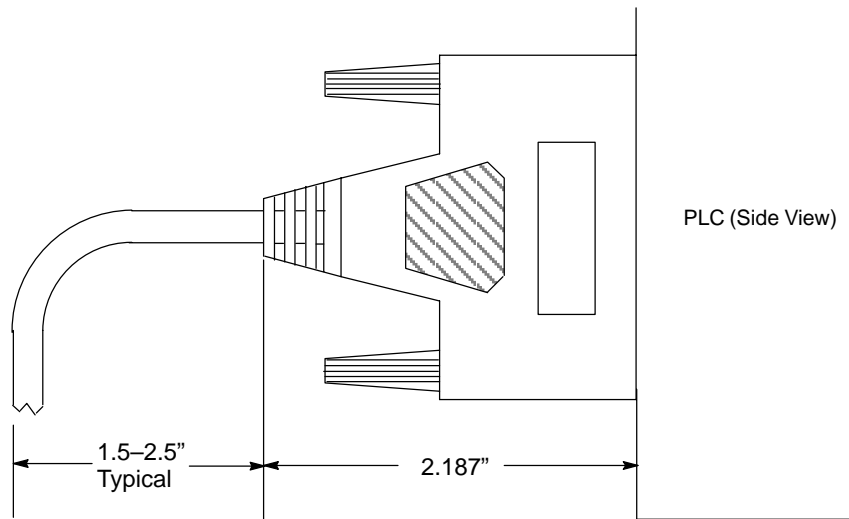

Figure 10-29. Dimensions for Depth of Connector in front of PLC

# IC693CBL311/317/319/320

## I/O Interface Cables for Power Mate APM Modules

### Function of cable

The I/O Interface Cable assembly consists of a 24-pin I/O connector, a cable, and a 25-pin D-type terminal block connector. This cable is used to connect the Power Mate APM Modules (IC693APU301 and IC693APU302) to drives and machines. There are two male 24-pin connectors mounted on the front of each Power Mate APM. Two of these I/O Interface cables are required for connections to and from the drive and machine. Catalog number IC693CBL311 is 10 feet (3 meters) in length and IC693CBL319 is 3 feet (1 meter) in length. The cable wire code list for these cables is provided in Table H-4.

An I/O cable assembly similar to IC693CBL311 and IC693CBL319, but with the drain shield wire disconnected from pin B12 and brought outside of the cable housing through an 8" pigtail, is also available in two lengths. Catalog number IC693CBL317 is 10 feet (3 meters) in length and IC693CBL320 is 3 feet (1 meter) in length. *This cable improves the Power Mate APM's noise immunity.* The cable wire code list for these cables is provided in Table 10-5.

To make wiring to the drive and machine easier, each connector on the module is typically connected by a short cable (the I/O Interface cable) to a terminal block. The cable that connects from the I/O connector to an external terminal block can be shortened to meet the requirements of your installation. See manuals GFK-0840 (standard moed) or GFK-0781 (follower mode) for details on APM terminal blocks.

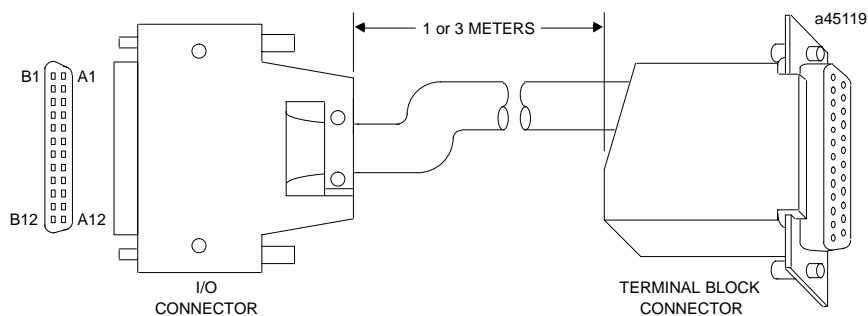

\* Cable for IC693CBL311/319 shown. Cables IC693CBL317/320 have 8" external wire connected to drain shield.

Figure 10-30. I/O Connector Cable Specifications

### Specifications

|                    |   |
|--------------------|---|
| <b>CableLength</b> | 10 feet (3 meters) and 3 feet (1 meter)                           |
| <b>Connector</b>   | 24-pin female, Fujitsu part number FCN-363J024 (crimp wire type). |

## Wiring Information

You must purchase the mating female (socket type) 24-pin connectors (which mate with the I/O Connector on the faceplate of the APM). This connector is available under catalog number IC693ACC317. This connector has a solder eyelet receptacle and is part of an accessory kit. Optionally, other types of the 24-pin connector (for different physical connections) are also available.

Catalog numbers for these connectors and their associated parts are listed in the following table. The list includes catalog numbers for three types of connectors: solder pin, crimp pin, and ribbon cable. *Each accessory kit contains enough components (D-connectors, backshells, contact pins, etc.) to assemble ten single-ended cables of the type specified for each kit.*

Table 10-5. Catalog Numbers for 24-Pin Connector Kits

| GE Fanuc Catalog Number             | Vendor Catalog Number | Description                           |
|-------------------------------------|-----------------------|---------------------------------------|
| IC693ACC316<br>(Solder Eyelet Type) | FCN-361J024-AU        | Solder eyelet receptacle              |
|                                     | FCN-360C024-B         | Backshell (for above)                 |
| IC693ACC317<br>(Crimp Type)         | FCN-363J024           | Crimp wire receptacle                 |
|                                     | FCN-363J-AU           | Crimp pin (for above, 24 needed)      |
|                                     | FCN-360C024-B         | Backshell (for above)                 |
| IC693ACC318<br>(Ribbon or IDC Type) | FCN-367J024-AUF       | IDC (ribbon) receptacle, closed cover |
|                                     | FCN-367J024-AUH       | IDC (ribbon) receptacle, open cover   |

NOTE: Wire for cables is 12 twisted pairs, #24 AWG (0.22mm<sup>2</sup>).

Additional tools from Fujitsu are required to properly assemble the crimped contact and ribbon cable type connectors. *The solder eyelet connectors (as provided in IC693ACC316) do not require any special tooling.*

Crimped Contact Connectors (as provided in IC693ACC317) require :

|                         |                 |
|-------------------------|-----------------|
| Hand Crimping Tool      | FCN-363T-T005/H |
| Contact Extraction Tool | FCN-360T-T001/H |

Ribbon Cable Connectors (as provided in IC693ACC318) require :

|               |                 |
|---------------|-----------------|
| Cable Cutter  | FCN-707T-T001/H |
| Hand Press    | FCN-707T-T101/H |
| Locator Plate | FCN-367T-T012/H |

These tools need to be ordered from an authorized Fujitsu distributor. Three of the largest US distributors for Fujitsu connectors are Marshall at (800)522-0084, Milgray at (800)MILGRAY, and Vantage at (800)843-0707. If none of these distributors service your area, then contact Fujitsu Microelectronics in San Jose, California, USA via telephone at (408) 922-9000 or via fax at (408) 954-0616 for further information.

It is recommended that you order any necessary connector tooling with sufficient lead time to meet your assembly requirements for these connectors. These tools are generally not stock items and can have significant lead times from distribution. If you have any further questions about this issue, please feel free to contact the GE Fanuc PLC Hotline at 1-800-GE FANUC (1-800-433-2682) or 804-978-6036.

The following tables provides wiring information for the I/O Interface cables:

**Table 10-6. I/O Cable Wire Coding for IC693CBL311 and IC693CBL319**

| I/O Connector<br>Pin Number | Cable Wire            | 25-Pin Connector<br>Terminal Number* |
|-----------------------------|-----------------------|--------------------------------------|
| no connection               | Wire 1 Pair 1         | 25                                   |
| A1                          | Wire 2 Pair 1         | 12                                   |
| <b>B1</b>                   | <b>Wire 1 Pair 2</b>  | <b>24</b>                            |
| <b>A2</b>                   | <b>Wire 2 Pair 2</b>  | <b>11</b>                            |
| B2                          | Wire 1 Pair 3         | 23                                   |
| A3                          | Wire 2 Pair 3         | 10                                   |
| <b>B3</b>                   | <b>Wire 1 Pair 4</b>  | <b>22</b>                            |
| <b>A4</b>                   | <b>Wire 2 Pair 4</b>  | <b>9</b>                             |
| B4                          | Wire 1 Pair 5         | 15                                   |
| A5                          | Wire 2 Pair 5         | 2                                    |
| <b>B5</b>                   | <b>Wire 1 Pair 6</b>  | <b>14</b>                            |
| <b>A6</b>                   | <b>Wire 2 Pair 6</b>  | <b>1</b>                             |
| B6                          | Wire 1 Pair 7         | 16                                   |
| A7                          | Wire 2 Pair 7         | 3                                    |
| <b>B7</b>                   | <b>Wire 1 Pair 8</b>  | <b>17</b>                            |
| <b>A8</b>                   | <b>Wire 2 Pair 8</b>  | <b>4</b>                             |
| B8                          | Wire 1 Pair 9         | 21                                   |
| A9                          | Wire 2 Pair 9         | 8                                    |
| <b>B9</b>                   | <b>Wire 1 Pair 10</b> | <b>20</b>                            |
| <b>A10</b>                  | <b>Wire 2 Pair 10</b> | <b>7</b>                             |
| B10                         | Wire 1 Pair 11        | 19                                   |
| A11                         | Wire 2 Pair 11        | 6                                    |
| <b>B11</b>                  | <b>Wire 1 Pair 12</b> | <b>18</b>                            |
| <b>A12</b>                  | <b>Wire 2 Pair 12</b> | <b>5</b>                             |
| B12                         | Drain Wire (Shield)   | 13                                   |

\* Same as Terminal Block Terminal Number. See manuals GFK-0840 (standard mode) or GFK-0781 (follower mode) for terminal block details.

Table 10-7. I/O Cable Wire Coding for IC693CBL317 and IC693CBL320

| I/O Connector Pin Number | Cable Wire Color Codes                    | 25-Pin Connector Terminal Number <sup>1</sup> |
|--------------------------|---|---|
| no connection            | Wire 1 Pair1(Brown/Black)                 | 25  |
| A1                       | Wire 2 Pair 1 (Brown)                     | 12  |
| <b>B1</b>                | <b>Wire 1 Pair 2 (Red/Black)</b>          | <b>24</b>                                     |
| <b>A2</b>                | <b>Wire 2 Pair 2 (Red)</b>                | <b>11</b>                                     |
| B2                       | Wire 1 Pair3(Orange/Black)                | 23  |
| A3                       | Wire 2 Pair 3 (Orange)                    | 10  |
| <b>B3</b>                | <b>Wire 1 Pair 4 (Yellow/Black)</b>       | <b>22</b>                                     |
| <b>A4</b>                | <b>Wire 2 Pair 4 (Yellow)</b>             | <b>9</b>                                      |
| B4                       | Wire 1 Pair5(Green/Black)                 | 15  |
| A5                       | Wire 2 Pair 5 (Green)                     | 2   |
| <b>B5</b>                | <b>Wire 1 Pair6(Blue/Black)</b>           | <b>14</b>                                     |
| <b>A6</b>                | <b>Wire 2 Pair 6 (Blue)</b>               | <b>1</b>                                      |
| B6                       | Wire 1 Pair 7 (Violet/Black)              | 16  |
| A7                       | Wire 2 Pair 7 (Violet)                    | 3   |
| <b>B7</b>                | <b>Wire 1 Pair8(White/Black)</b>          | <b>17</b>                                     |
| <b>A8</b>                | <b>Wire 2 Pair 8 (White)</b>              | <b>4</b>                                      |
| B8                       | Wire 1 Pair9(Gray/Black)                  | 21  |
| A9                       | Wire 2 Pair 9 (Gray)                      | 8   |
| <b>B9</b>                | <b>Wire 1 Pair 10 (Pink/Black)</b>        | <b>20</b>                                     |
| <b>A10</b>               | <b>Wire 2 Pair 10 (Pink)</b>              | <b>7</b>                                      |
| B10                      | Wire 1 Pair11 (LightBlue/Black)           | 19  |
| A11                      | Wire 2 Pair 11 (Light Blue)               | 6   |
| <b>B11</b>               | <b>Wire 1 Pair 12 (Light Green/Black)</b> | <b>18</b>                                     |
| <b>A12</b>               | <b>Wire 2 Pair 12 (Light Green)</b>       | <b>5</b>                                      |
| External Ring Terminal   | Drain Wire (Shield) <sup>2</sup>          | 13  |

<sup>1</sup> Same as Terminal Block Terminal Number.

<sup>2</sup> 16 gauge wire, green w/yellow tracer. 8" length (from back of connector), terminates with a #10 ring terminal.

# IC693CBL315

## I/O Interface Cable (24-Pin) for 32 Point Modules

Note: This cable became obsolete in late 1998. It was replaced by two cables: IC693CBL327 and IC693CBL328. See the data sheet for these cables for details. The replacement cables have right-angle connectors to reduce the clearance space required in front of the PLC.

### Function of cable

This prewired cable is available for use with all Series 90-30 high-density (32 point) I/O modules that use the Fujitsu 24-pin user I/O connector. Each of these modules has two of these connectors mounted side-by-side. I/O Interface cables have a 24-pin connector on one end for connection to the module, and stripped and tinned wires on the other end. Catalog numbers for 32 point modules having two 24-pin connectors are: IC693MDL654, IC693MDL655, IC693MDL752, and IC693MDL753.

Connections to input circuits are made from the user's input devices to two male (pin-type) 24-pin connectors (Fujitsu FCN-365P024-AU) mounted on the front of the module. The connector mounted on the right of the module (front view) interfaces with groups A and B; the connector mounted on the left side of the module interfaces with groups C and D. If a different length cable is required for connections to these modules, you can build your own cable.

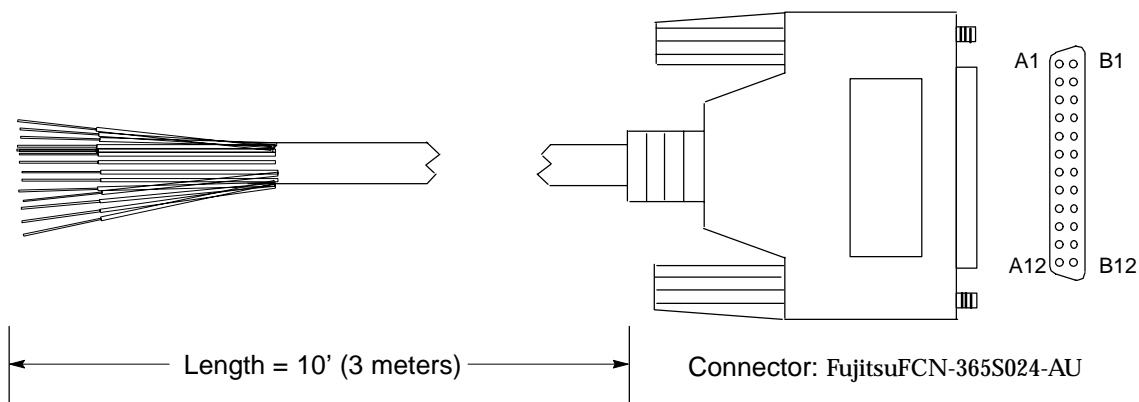

Figure 10-31. IC693CBL315 Cable

## Building Custom Length Cables for 24-Pin Connectors

Cables connecting the module to field devices can be built to length as required for individual applications. You must purchase the mating female (socket type) 24-pin connectors. The 24-pin connector kit can be ordered as an accessory kit from GE Fanuc. Catalog numbers for these connectors and their associated parts are listed in the following table. The list includes catalog numbers for three types of connectors: solder pin, crimp pin, and ribbon cable. *Each accessory kit contains enough components (D-connectors, backshells, contact pins, etc.) to assemble ten single-ended cables of the type specified for each kit.*

Table 10-8. Catalog Numbers for 24-Pin Connector Kits

| GE Fanuc Catalog Number             | Vendor Catalog Number | Description                           |
|-------------------------------------|-----------------------|---------------------------------------|
| IC693ACC316<br>(Solder Eyelet Type) | FCN-361J024-AU        | Solder eyelet receptacle              |
|                                     | FCN-360C024-B         | Backshell (for above)                 |
| IC693ACC317<br>(Crimp Type)         | FCN-363J024           | Crimp wire receptacle                 |
|                                     | FCN-363J-AU           | Crimp pin (for above, 24 needed)      |
|                                     | FCN-360C024-B         | Backshell (for above)                 |
| IC693ACC318<br>(Ribbon or IDC Type) | FCN-367J024-AUF       | IDC (ribbon) receptacle, closed cover |
|                                     | FCN-367J024-AUH       | IDC (ribbon) receptacle, open cover   |

Additional tools from Fujitsu are required to properly assemble the crimped contact and ribbon cable type connectors. *The solder eyelet connectors (as provided in IC693ACC316) do not require any special tooling.*

*Crimped Contact Connectors (as provided in IC693ACC317) require :*

|                         |                 |
|-------------------------|-----------------|
| Hand Crimping Tool      | FCN-363T-T005/H |
| Contact Extraction Tool | FCN-360T-T001/H |

*Ribbon Cable Connectors (as provided in IC693ACC318) require :*

|               |                 |
|---------------|-----------------|
| Cable Cutter  | FCN-707T-T001/H |
| Hand Press    | FCN-707T-T101/H |
| Locator Plate | FCN-367T-T012/H |

These tools need to be ordered from an authorized Fujitsu distributor. Three of the largest US distributors for Fujitsu connectors are Marshall at (800)522-0084, Milgray at (800)MILGRAY, and Vantage at (800)843-0707. If none of these distributors service your area, then contact Fujitsu Microelectronics in San Jose, California, USA via telephone at (408) 922-9000 or via fax at (408) 954-0616 for further information.

It is recommended that you order any necessary connector tooling with sufficient lead time to meet your assembly requirements for these connectors. These tools are generally not stock items and can have significant lead times from distribution. If you have any further questions about this issue, please feel free to contact the GE Fanuc PLC Technical Support Hotline at 1-800-GE FANUC (1-800-433-2682), or International dial direct 804-978-6036.

Pin connections with color codes are shown in the following table. Cables are made of 12 twisted pairs; wire size is #24 AWG (0.22mm<sup>2</sup>).

Table 10-9. Wire List for 24-Pin Connectors

| Pin Number | Pair # | Wire Color Code |
|------------|--------|-----------------|
| A1         | 1      | BROWN           |
| A2         | 1      | BROWN/BLACK     |
| A3         | 2      | RED             |
| A4         | 2      | RED/BLACK       |
| A5         | 3      | ORANGE          |
| A6         | 3      | ORANGE/BLACK    |
| A7         | 4      | YELLOW          |
| A8         | 4      | YELLOW/BLACK    |
| A9         | 5      | DARKGREEN       |
| A10        | 5      | DARKGREEN/BLACK |
| A11        | 6      | DARKBLUE        |
| A12        | 6      | DARKBLUE/BLACK  |

| Pin Number | Pair # | Wire Color Code  |
|------------|--------|------------------|
| B1         | 7      | VIOLET           |
| B2         | 7      | VIOLET/BLACK     |
| B3         | 8      | WHITE            |
| B4         | 8      | WHITE/BLACK      |
| B5         | 9      | GRAY             |
| B6         | 9      | GRAY/BLACK       |
| B7         | 10     | PINK             |
| B8         | 10     | PINK/BLACK       |
| B9         | 11     | LIGHTBLUE        |
| B10        | 11     | LIGHTBLUE/BLACK  |
| B11        | 12     | LIGHTGREEN       |
| B12        | 12     | LIGHTGREEN/BLACK |

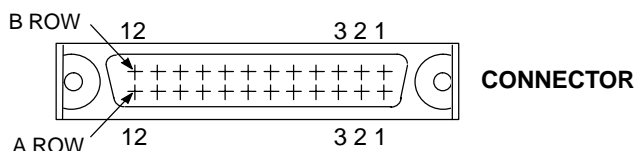

**NOTE**

Each wire pair has a solid color wire and that same color wire with a black tracer. For example, Pair 1 has a solid brown wire paired with a brown wire with a black tracer.

**Replacement/Obsolescence Information**

- Cable IC693CBL315 (now obsolete also) replaced cable IC693CBL310 when that cable became obsolete. The only difference between these two cables is in the wire color coding.
- When cable IC693CBL315 became obsolete, the replacement for these cables became IC693CBL327 and IC693CBL328. Cables IC693CBL310/315 have straight connectors. Cables IC693CBL327/328 have right angle connectors. The right angle connectors require less depth in front of the PLC, so allow the use of a smaller enclosure in some applications.

### Connector Depth for IC693CBL315

The following illustration shows the space required in front of the PLC when this cable is connected to a module. The depth of the cabinet that the PLC is mounted in should allow for the depth added by this connector.

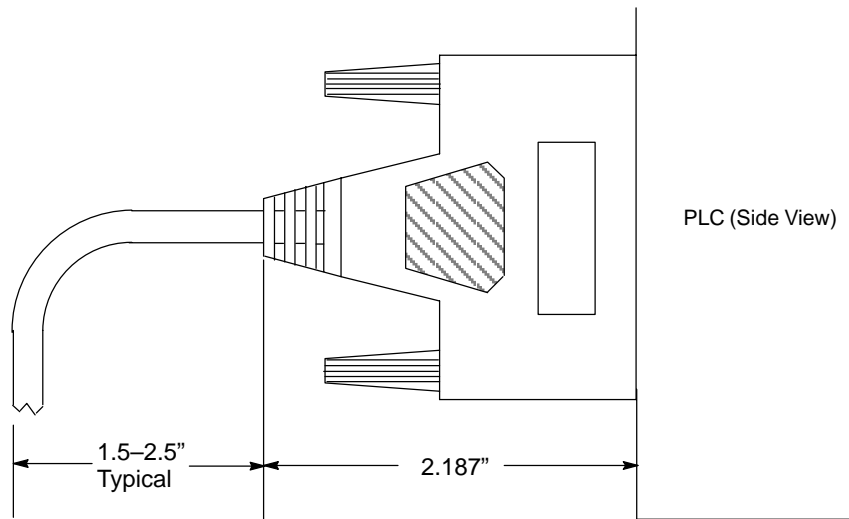

Figure 10-32. Dimensions for Depth of Connector in front of PLC

# IC693CBL316

## Serial Cable, 9-Pin D-Shell to RJ-11 Connector

### Description

The IC693CBL316 cable is a 3-feet (1 meter) long, shielded cable with a 9-pin D-shell connector on one end and a 6-pin RJ-11 connector on the other. This cable is also known as a “Station Manager Cable.” This cable can interconnect RS-232 ports without the need for a converter.

### Typical Applications

- Connect a Personal Computer’s 9-pin serial port to the RJ-11 faceplate serial port on CPUs 351, 352, and 363 for programming, configuring, firmware updating, and monitoring purposes.
- Connect a Personal Computer’s 9-pin serial port to the Station Manager port on an IC693CMM321 Ethernet module or on an IC693CPU364 CPU module, which has a built-in Ethernet interface.
- Connect a Personal Computer’s 9-pin serial port to an IC693DSM302 module’s RJ-11 COMM port for loading motion programs (1 - 10) and firmware.
- Connect a Personal Computer’s 9-pin serial port to an IC693DSM314 module’s RJ-11 COMM port for loading firmware (motion programs for this module are loaded across the PLC backplane).

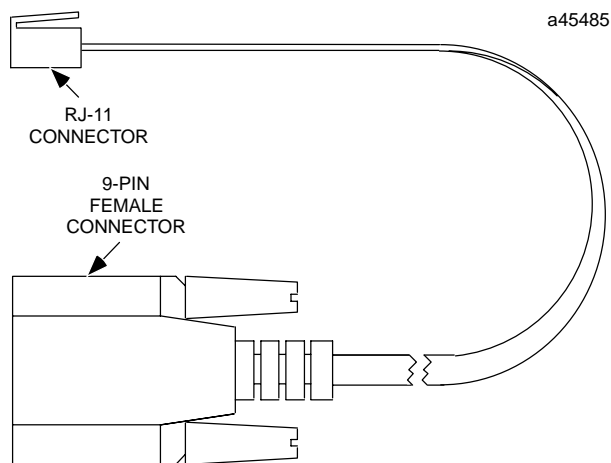

| 9-Pin Connector Pin Number | RJ-11 Connector Pin Number |
|----------------------------|----------------------------|
| 7                          | 1 (Red)                    |
| 2                          | 2 (Yellow)                 |
| 5                          | 3 (Green)                  |
| 5                          | 4 (Brown)                  |
| 3                          | 5 (Black)                  |
| 8                          | 6 (Orange)                 |

Figure 10-33. IC693CBL316A Serial Cable Illustration and Connector Pinouts

## IC693CBL321/322/323

### I/O Faceplate Connector to Terminal Block Connector, 24-Pin

Note: These cables became obsolete in late 1998. They were replaced by six cables: IC693CBL329, IC693CBL330, IC693CBL331, IC693CBL332, IC693CBL333, and IC693CBL334. See the data sheet for these cables for details. The replacement cables have right-angle connectors to reduce the clearance space required in front of the PLC.

#### Function of cable

These cables are used with 16-point I/O modules that are equipped with a TBQC I/O faceplate adaptor. Each cable has a straight 24-pin female connector on both ends. Each cable provides a connection from the module to a connector mounted on a terminal block assembly. These cables are wired pin-to-pin (that is, pin A1 to pin A1, pin A2 to pin A2, etc.). An I/O faceplate assembly (catalog number IC693ACC334) is required which snaps onto the module in place of the module's standard 20-pin terminal block assembly. Five different terminal blocks are available to allow a variety of I/O modules to use this accessory (see Appendix J for details on the TBQC assemblies).

#### Cable Specifications

| Item  | Description   |
|---|---|
| <b>CableLength †</b><br>IC693CBL321<br>IC693CBL322<br>IC693CBL323 | 3 feet (1 meter),<br>6 feet (2 meters)<br>1.5 feet (0.5 meters)                 |
| <b>Cable Type:</b>  | 12 twisted pairs with overall aluminum polyester shield and #24 AWG drain wire. |
| <b>24 Pin Female Connectors (2):</b>                              | Equivalent to Fujitsu FCN-363J024, or equivalent.                               |

† Length of cable is measured from backs of connector shells as shown in figure on next page.

The connector on the I/O faceplate is oriented as shown below, with the rows labeled A1-A12 and B1-B12. A1 and B1 are towards top of module faceplate.

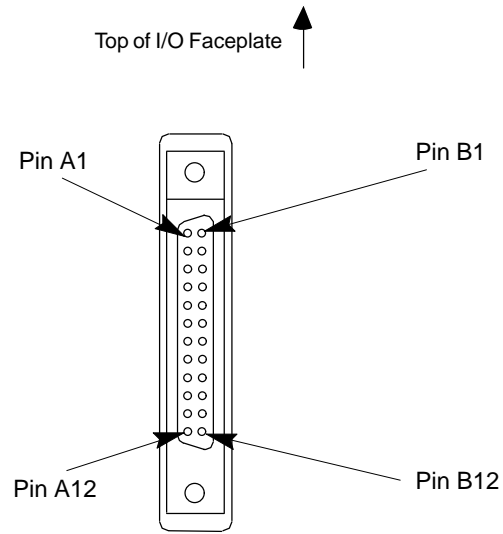
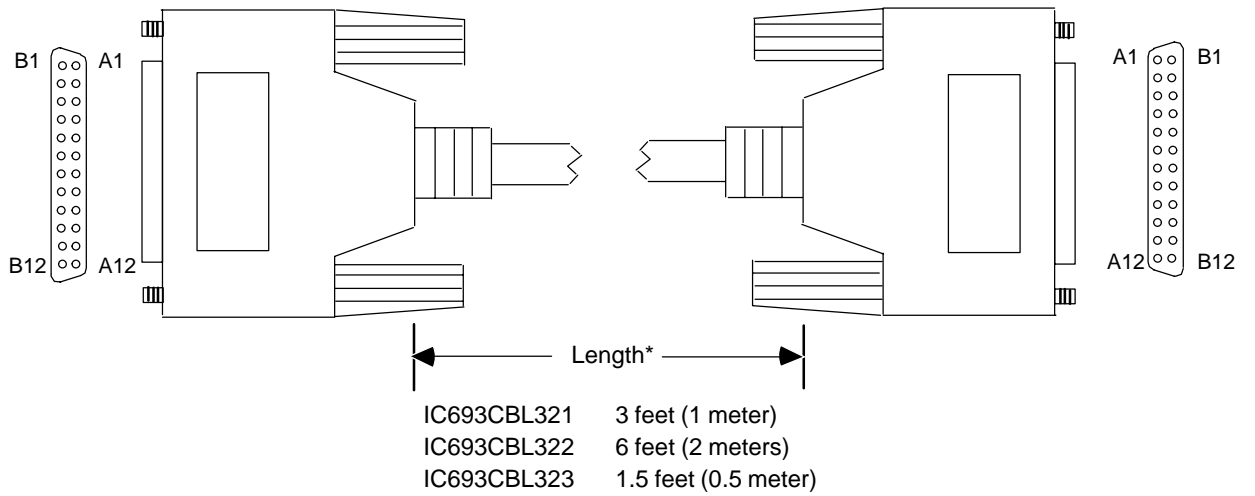

Figure 10-34. Connector Orientation on I/O Faceplate



\* Length is measured from backs of connector shells as shown above

Figure 10-35. I/O Faceplate to Terminal Block Cable

### Connector Depth

The following illustration shows the space required in front of the PLC when this cable is connected to a module. The depth of the cabinet that the PLC is mounted in should allow for the depth added by this connector.

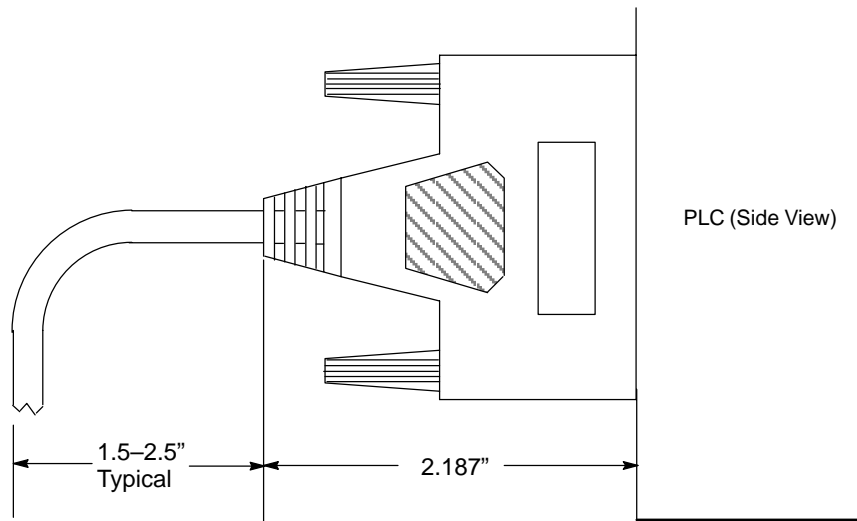

Figure 10-36. Dimensions for Depth of Connector in front of PLC

## IC693CBL327/328

### I/O Interface Cables with Right Angle 24-Pin Connector

**Note:** These cables replace obsolete I/O Interface cable IC693CBL315. These replacement cables have right-angle connectors to reduce the clearance space required in front of the PLC. These replacement cables use the same pin-outs as the obsolete cables.

#### Description

These cables each have a right-angle 24-pin connector on one end and a set of stripped wire ends on the other. These two cables are identical except for their opposite connector orientations. This difference in the cables' connector orientations is for the purpose of matching the opposing connector orientations on the dual-connector type of 32-point I/O modules.

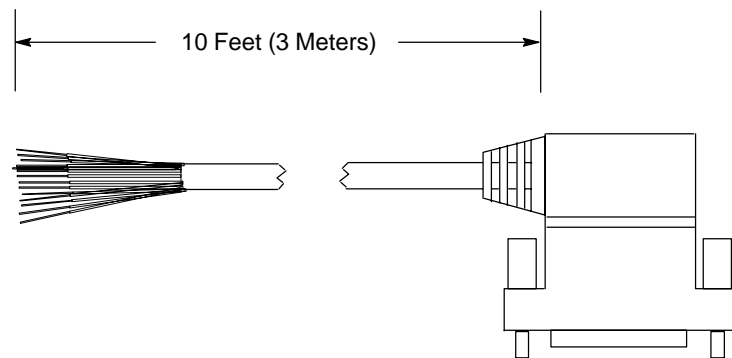

Figure 10-37. IC693CBL327/328 Cables

#### Note

Each conductor in these 24-conductor cables has a current rating of 1.2 Amps. If using these cables with a 16-point Output module with a higher output current rating, you must use the lower value of 1.2 for the maximum load current rating. If you have field devices that require more than 1.2 Amps, do not use a TBQC assembly. Use the standard Terminal Board instead.

#### Applications

These cables are for use with Series 90-30 I/O modules that have the Fujitsu 24-pin user I/O connector. There are two categories of these modules:

- **32 point modules** with two 24-pin connectors (IC693MDL654, IC693MDL655, IC693MDL752, and IC693MDL753). The IC693CBL327 cable is for the modules' left side connector (front view), and the IC693CBL328 cable is for the modules' right side connector. The modules' right side connector interfaces with I/O circuit groups A and B; the modules' left side connector interfaces with groups C and D. See Chapter 7, "Input and Output Modules" for a drawing of these modules. See GFK-0898, the *Series 90-30 PLC I/O Module Specifications Manual*, for details about these modules.

- **16-point modules** that are equipped with the TBQC I/O faceplate adaptor. See Appendix J for information on the TBQC (Terminal Block Quick Connector). Use the IC693CBL328 right side cable for this application.

If a different length cable is required, you can build your own cable, but only straight connector kits are currently available. See “Building Custom Length Cables” below.

### Specifications

|                    |                       |
|--------------------|-----------------------|
| <b>CableLength</b> | 10 feet (3 meters)    |
| <b>Connector</b>   | FujitsuFCN-365S024-AU |

### Connector Depth for Cables IC693CBL327/328

The following figure shows that these cables extend 2” out from the face of the modules they are connected to. The depth of the cabinet that the PLC is mounted in should allow for the 2” depth added by this connector.

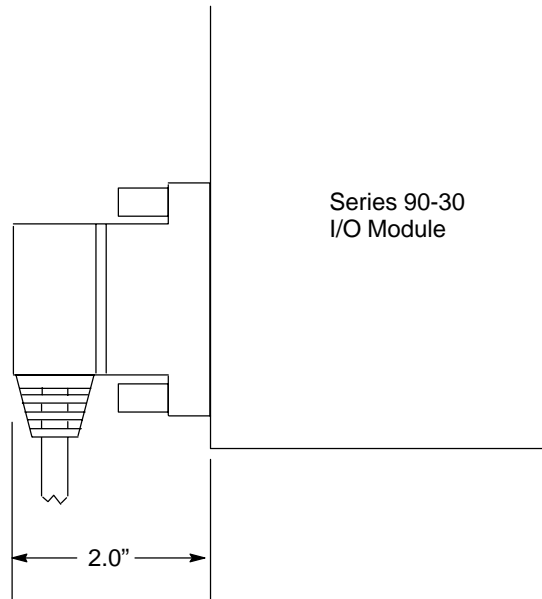

Figure 10-38. Dimension for Depth of Connector for IC693CBL327/328

## Building Custom Length 24-pin Connector Cables

Cables connecting the module to field devices can be built to length as required for individual applications. You must purchase the mating female (socket type) 24-pin connectors. The 24-pin connector kit can be ordered as an accessory kit from GE Fanuc. Catalog numbers for these connectors and their associated parts are listed in the following table. The list includes catalog numbers for three types of connectors: solder pin, crimp pin, and ribbon cable. *Each accessory kit contains enough components (D-connectors, backshells, contact pins, etc.) to assemble ten single-ended cables of the type specified for each kit.*

Table 10-10. Catalog Numbers for 24-Pin Connector Kits

| GE Fanuc Catalog Number             | Vendor Catalog Number | Description                           |
|-------------------------------------|-----------------------|---------------------------------------|
| IC693ACC316<br>(Solder Eyelet Type) | FCN-361J024-AU        | Solder eyelet receptacle              |
|                                     | FCN-360C024-B         | Backshell (for above)                 |
| IC693ACC317<br>(Crimp Type)         | FCN-363J024           | Crimp wire receptacle                 |
|                                     | FCN-363J-AU           | Crimp pin (for above, 24 needed)      |
|                                     | FCN-360C024-B         | Backshell (for above)                 |
| IC693ACC318<br>(Ribbon or IDC Type) | FCN-367J024-AUF       | IDC (ribbon) receptacle, closed cover |
|                                     | FCN-367J024-AUH       | IDC (ribbon) receptacle, open cover   |

Additional tools from Fujitsu are required to properly assemble the crimped contact and ribbon cable type connectors. *The solder eyelet connectors (as provided in IC693ACC316) do not require any special tooling.*

*Crimped Contact Connectors (as provided in IC693ACC317) require :*

|                         |                 |
|-------------------------|-----------------|
| Hand Crimping Tool      | FCN-363T-T005/H |
| Contact Extraction Tool | FCN-360T-T001/H |

*Ribbon Cable Connectors (as provided in IC693ACC318) require :*

|               |                 |
|---------------|-----------------|
| Cable Cutter  | FCN-707T-T001/H |
| Hand Press    | FCN-707T-T101/H |
| Locator Plate | FCN-367T-T012/H |

These tools need to be ordered from an authorized Fujitsu distributor. Three of the largest US distributors for Fujitsu connectors are Marshall at (800)522-0084, Milgray at (800)MILGRAY, and Vantage at (800)843-0707. If none of these distributors service your area, then contact Fujitsu Microelectronics in San Jose, California, USA via telephone at (408) 922-9000 or via fax at (408) 954-0616 for further information.

It is recommended that you order any necessary connector tooling with sufficient lead time to meet your assembly requirements for these connectors. These tools are generally not stock items and can have significant lead times from distribution. If you have any further questions about this issue, please feel free to contact the GE Fanuc PLC Technical Support Hotline at 1-800-GE FANUC (1-800-433-2682), or International dial direct 804-978-6036.

Pin connections with color codes are shown in the following table. Cables are made of 12 twisted pairs; wire size is #24 AWG (0.22mm<sup>2</sup>).

**Table 10-11. Wire List for 24-Pin Connectors**

| Pin Number | Pair # | Wire Color Code |
|------------|--------|-----------------|
| A1         | 1      | BROWN           |
| A2         | 1      | BROWN/BLACK     |
| A3         | 2      | RED             |
| A4         | 2      | RED/BLACK       |
| A5         | 3      | ORANGE          |
| A6         | 3      | ORANGE/BLACK    |
| A7         | 4      | YELLOW          |
| A8         | 4      | YELLOW/BLACK    |
| A9         | 5      | DARKGREEN       |
| A10        | 5      | DARKGREEN/BLACK |
| A11        | 6      | DARKBLUE        |
| A12        | 6      | DARKBLUE/BLACK  |

| Pin Number | Pair # | Wire Color Code  |
|------------|--------|------------------|
| B1         | 7      | VIOLET           |
| B2         | 7      | VIOLET/BLACK     |
| B3         | 8      | WHITE            |
| B4         | 8      | WHITE/BLACK      |
| B5         | 9      | GRAY             |
| B6         | 9      | GRAY/BLACK       |
| B7         | 10     | PINK             |
| B8         | 10     | PINK/BLACK       |
| B9         | 11     | LIGHTBLUE        |
| B10        | 11     | LIGHTBLUE/BLACK  |
| B11        | 12     | LIGHTGREEN       |
| B12        | 12     | LIGHTGREEN/BLACK |

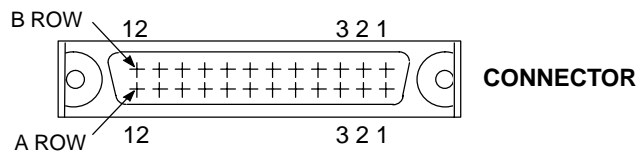

a45144

**NOTE**

Each wire pair has a solid color wire and that same color wire with a black tracer. For example, Pair 1 has a solid brown wire paired with a brown wire with a black tracer.

## Connector Depth for Custom Built Cables

Because custom built cables use a straight connector, they require more space in front of the PLC than is required for a factory built cable, which has a right-angle connector. The following figure shows the space required in front of the PLC when this cable is connected to a module. The depth of the cabinet that the PLC is mounted in should allow for the depth added by this connector.

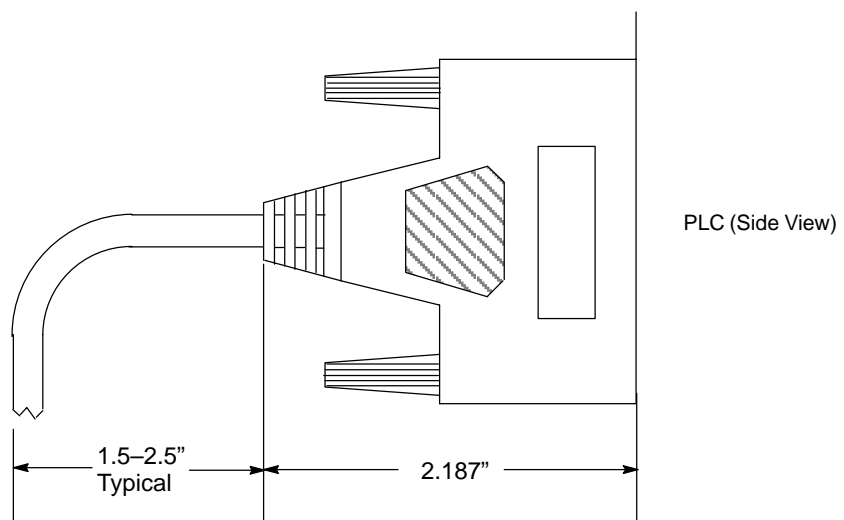

Figure 10-39. Dimensions for Depth of Connector in front of PLC for Custom Built Cables

## Possible Uses for These Cables (Factory or Custom Built)

- Connecting from the 24-pin connectors on a 32-point module to either a user-supplied terminal strip/block or directly to I/O field devices (switches, lights, etc.).
- Connecting from the 24-pin connector on a 16-point module that has a TBQC I/O faceplate adapter to either a user-supplied terminal strip/block or directly to I/O field devices (switches, lights, etc.). Use the right side cable, IC693CBL328, for this purpose. See Appendix J for information about TBQC (Terminal Block Quick Connect) options.
- Connecting from the 24-pin connectors on a 32-point module through a conduit to a Terminal Block Quick Connect terminal block. This can be accomplished by attaching one of the optional 24-pin connectors to the stripped end after pulling the cable through the conduit. See the section “Building Custom Length Cables” for information on the connector options. See Appendix J for information about TBQC (Terminal Block Quick Connect) options.
- Connecting from the connector on a 16-point module that has a TBQC I/O faceplate adapter through a conduit to a TBQC terminal block. This can be accomplished by attaching one of the optional 24-pin connectors to the stripped end after pulling the cable through the conduit. Use the right side cable, IC693CBL328, for this purpose. See the section “Building Custom Length Cables” for information on the connector options. See Appendix J for information about TBQC (Terminal Block Quick Connect) options.

## IC693CBL329/330/331/332/333/334 Cables

### 24-Pin I/O Faceplate Connector to Terminal Block Connector

**Note:** These cables replace obsolete cables IC693CBL321/322/323. The obsolete cables had straight connectors. These replacement cables have right-angle connectors to reduce the clearance space required in front of the PLC. They use the same pin-outs as the obsolete cables.

#### Description

These cables all have a right-angle 24-pin connector on each end. They are identical except for connector orientation (right side and left side types) and cable length. The difference in connector orientation is to allow them to work with the dual-connector type of 32-point I/O modules. These cables are wired pin-to-pin (that is, pin A1 to pin A1, pin A2 to pin A2, etc.). Similar cables are available in a 3 meter length that have a right angle connector on one end and stripped leads on the other (see the data sheet for the IC693CBL327/328 cables for further information).

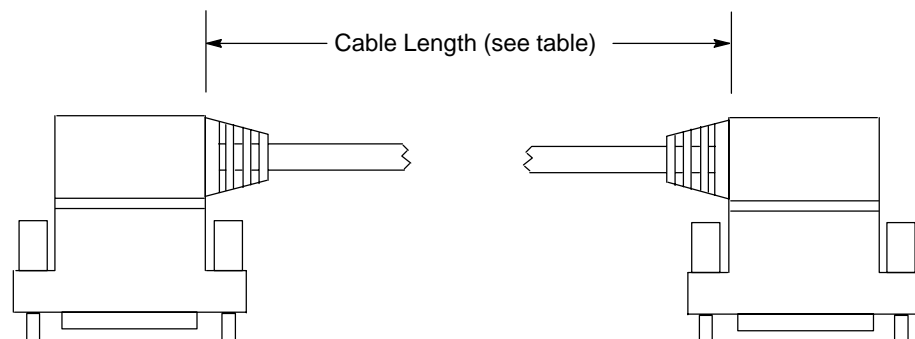

Figure 10-40. IC693CBL329/330/331/332/333/334 Cables

#### Note

Each conductor in these 24-conductor cables has a current rating of 1.2 Amps. If using these cables with a 16-point Output module with a higher output current rating, you must use the lower value of 1.2 for the maximum load current rating. If you have field devices that require more than 1.2 Amps, do not use a TBQC assembly. Use the standard Terminal Board instead.

Table 10-12. TBQC Cable Cross-Reference Table

| Cable Catalog Number | Cable Description and Length   | Replaces Obsolete Cable Number |
|----------------------|--|--------------------------------|
| IC693CBL329          | Dual 24-pin, 90 deg. connectors, Left Side<br>Cable length = 1.0 Meter                   | IC693CBL321                    |
| IC693CBL330          | Dual 24-pin, 90 deg. connectors, Right Side<br>Cable length = 1.0 Meter                  | IC693CBL321                    |
| IC693CBL331          | Dual 24-pin, 90 deg. connectors, Left Side<br>Cable length = 2.0 Meters                  | IC693CBL322                    |
| IC693CBL332          | Dual 24-pin, 90 deg. connectors, Right Side<br>Cable length = 2.0 Meters                 | IC693CBL322                    |
| IC693CBL333          | Dual 24-pin, 90 deg. connectors, Left Side<br>Cable length = 0.5 Meter                   | IC693CBL323                    |
| IC693CBL334          | Dual 24-pin, 90 deg. connectors, Right Side<br>Cable length = 0.5 Meter                  | IC693CBL323                    |
| <b>Cable Kits</b>    |  |                                |
| IC693CBK002          | Cable Kit. Includes both the IC693CBL329 (left side) and IC693CBL330 (right side) cables |                                |
| IC693CBK003          | Cable Kit. Includes both the IC693CBL331 (left side) and IC693CBL332 (right side) cables |                                |
| IC693CBK004          | Cable Kit. Includes both the IC693CBL333 (left side) and IC693CBL334 (right side) cables |                                |

**Connector Depth**

The following figure shows that the cable connectors extend 2” out from the face of the Series 90-30 modules they are connected to. The depth of the cabinet that the PLC is mounted in should allow for the 2” depth added by this connector.

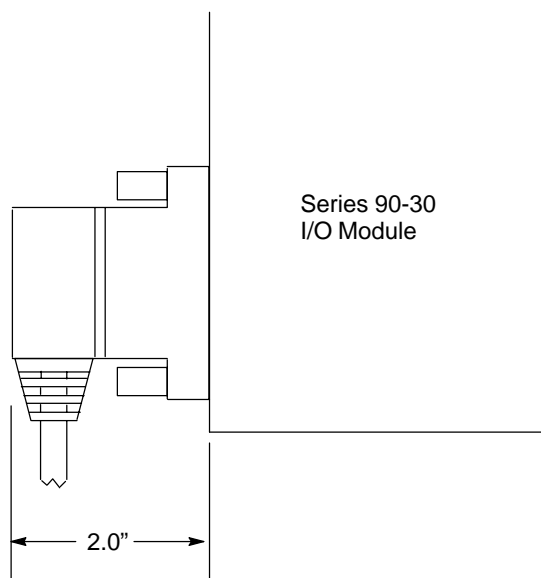

Figure 10-41. Dimension for Depth of Connector

## Applications

These cables connect from Series 90-30 I/O modules that use the Fujitsu 24-pin I/O connector to Terminal Block Quick Connect (TBQC) blocks. There are two categories of these modules:

- **32 point modules** with two 24-pin connectors: IC693MDL654, IC693MDL655, IC693MDL752, and IC693MDL753. The IC693CBL329.331.333 cables are for the modules' left side connector (front view), and the IC693CBL330.332.334 cables are for the modules' right side connector. The modules' right side connector interfaces with I/O circuit groups A and B; the modules' left side connector interfaces with groups C and D. The other end of the cables connect to the TBQC IC693ACC337 terminal block. See GFK-0898, the *Series 90-30 PLC I/O Module Specifications Manual*, for details about these modules. See Appendix J for information on the TBQC components.
- **16-point modules** that are equipped with the TBQC I/O faceplate adaptor. Use the IC693CBL330/332/334 right side cables for this application. See Appendix J for information on the TBQC (Terminal Block Quick Connector) components.

# IC693CBL340/341 PTM Interface Cables –Preliminary Information

## Note

**This information was preliminary at the time of writing and could change by the time the PTM is released. The PTM is expected to be available in late 1999. Please contact your distributor for up-to-date information.**

These cables connect the PTM Processor Module (PTMPM) to the PTM Interface Module (PTMIM).

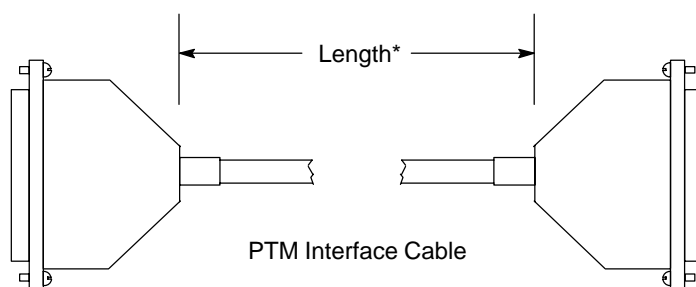

\*Length of IC693CBL340 Cable is 19" (0.50 meter)  
\*Length of IC693CBL341 Cable is 39" (1 meter)

Figure 10-42. IC693CBL340/341 PTM Interface Cables

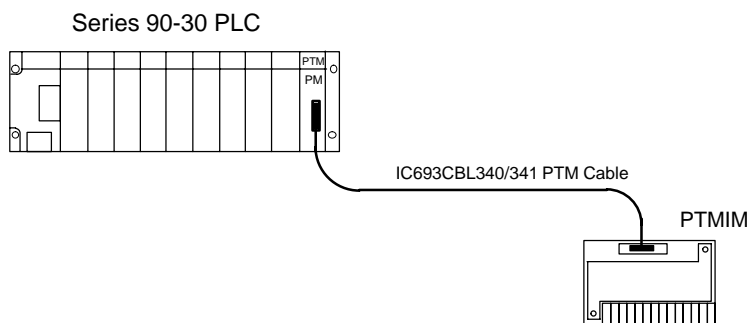

Figure 10-43. IC693PTM100 PTM Component Mounting

## Warning

**The PTMIM board connects to hazardous voltages. Before installing, testing, or troubleshooting this board, you should refer to the complete instructions in the PTM User's Manual, GFK-1734 (see "Documentation" section below). Failure to follow the guidelines in the PTM User's Manual may result in personal injury, equipment damage, or both.**

## Checking the IC693CBL340/341 Cables

The following information is supplied for the purpose of troubleshooting only (making continuity checks of the cable). These cables have straight through connections (pin 1 connects to pin 1, pin 2 connects to pin 2, etc.), although some pins have no connections. One end is connected to a male, all plastic DB-25 connector. The other end is connected to a female, all plastic DB-25 connector. The cable is a twisted-pair type, connected to minimize noise and crosstalk between signals.

### Warning

**These cables connect to a circuit board that has hazardous voltages present. These cables are carefully made to ensure the safety of the user and associated equipment. Therefore, we recommend you use only factory-built cables.**

| Connector Pin Number (Either End) | Signal Name and Function             |
|-----------------------------------|--------------------------------------|
| 1                                 | VG+, Voltage Generator positive lead |
| 2                                 | IN+, Current Neutral positive lead   |
| 3                                 | VA+, Voltage phase A positive lead   |
| 4                                 | IA+, Current phase A positive lead   |
| 5                                 | No Connection                        |
| 6                                 | VB+, Voltage phase B positive lead   |
| 7                                 | IB+, Current phase B positive lead   |
| 8                                 | VC+, Voltage phase C positive lead   |
| 9                                 | IC+, Current phase C positive lead   |
| 10                                | Cable shield                         |
| 11                                | No Connection                        |
| 12                                | Frame Ground                         |
| 13                                | No Connection                        |
| 14                                | VG-, Voltage Generator negative lead |
| 15                                | IN-, Current Neutral negative lead   |
| 16                                | VA-, Voltage phase A negative lead   |
| 17                                | IA-, Current phase A negative lead   |
| 18                                | No Connection                        |
| 19                                | VB-, Voltage phase B negative lead   |
| 20                                | IB-, Current phase B negative lead   |
| 21                                | VC-, Voltage phase C negative lead   |
| 22                                | IC-, Current phase C negative lead   |
| 23                                | No Connection                        |
| 24                                | No Connection                        |
| 25                                | Frame Ground                         |

---

## PTM Products Ordering Information

The PTMPM module and its PTMIM interface board are considered to be a matched set. Therefore, they are not sold separately. The two cables, however, may be ordered as separate items. There are four catalog numbers in the PTM product line:

- IC693PTM100 – This contains the PTMPM, its matched PTMIM, and the 19” (0.5 meter) interface cable.
- IC693PTM101 – This contains the PTMPM, its matched PTMIM, and the 39” (1 meter) interface cable.
- IC693CBL340 – The 19” (0.5 meter) interface cable.
- IC693CBL341 – The 39” (1 meter) interface cable.

## Documentation

The PTM user’s manual will not be available until early in the year 2000. It will be GFK-1734, *Series 90-30 PLC Power Transducer Module User’s Manual*.

# Chapter 11

## Programmer Hardware Products

[efesotomasyon.com](http://efesotomasyon.com)

---

---

### Products Discussed in this Chapter

The following table lists the programmer hardware products discussed in this chapter. Some of the items are no longer available but are documented here for the convenience of customers still using them.

| Catalog Number            | Description   | Comment   |
|---------------------------|---|---|
| IC640WMI310               | Work Station Interface (WSI) Board                      | For Workmaster or IBM PC and compatibles.           |
| IC640WMI320               | Work Station Interface (WSI) Board                      | For Workmaster II or IBM PS/2 and compatibles.      |
| IC690ACC900               | RS-422/485 to RS-232 Converter                          | No longer available. Use IC690ACC901 Miniconverter. |
| IC690ACC901               | Miniconverter   | Converts RS-422/485 to RS-232.                      |
| IC693PRG300               | Hand-Held Programmer (HHP)                              | Used to configure and program Series 90-30 PLCs.    |
| IC693ACC303               | Memory card for HHP                                     | Plugs into HHP. Used for file storage.              |
| IC693PIF301               | Personal Computer Interface Card                        | Installs in PC. Enables PC to control PLC I/O.      |
| IC693PIF400               | Personal Computer Interface Card                        | More "powerful" than the IC693PIF301.               |
| IC655CCM590 (IC630CCM390) | Isolated Repeater/Converter (also known as the "Brick") | No longer available. Use IC690ACC903 Port Isolator. |
| IC690ACC903               | Port Isolator   | Provides isolation for PLC serial port.             |

## IC640WMI310/320 Work Station Interface Boards

The Work Station Interface (WSI) board provides an RS-485 serial interface between a Series 90-30 PLC and a PC-compatible programmer running Logicmaster 90-30/20/Micro software. This board is available in two versions.

- IC640WMI310 (serial operation only) for Workmaster or IBM PC XT or AT or compatible personal computers.
- IC647WMI320 (serial operation only) for Workmaster II or IBM PS/2 or compatible personal computers.

The WSI board can be ordered as part of a package with Logicmaster 90-30/20/Micro programming software. When a Workmaster II computer was ordered as the programming device, the WSI board was installed at the factory. The WSI resides in a full length computer slot. The computer can be a Workmaster, Workmaster II, Cimstar industrial computer, or a PC-compatible personal computer.

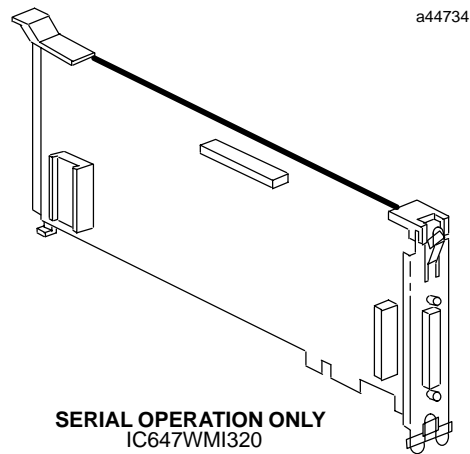

Figure 11-1. WSI Board for the Workmaster II Computer

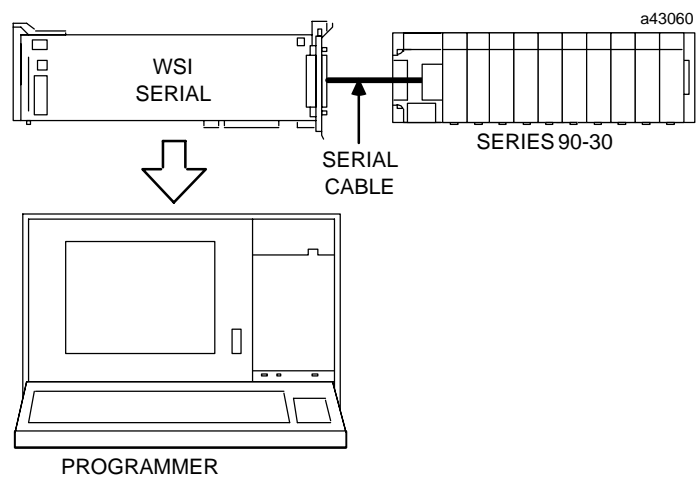

Figure 11-2. Location of WSI in a Series II 90-30 PLC System

---

## Replacing Workmaster Computers

The Workmaster and Workmaster II computers are no longer available. However, the Work Station Interface boards are still sold, largely to support customers still using the Workmaster and related products. GE Fanuc currently sells industrially hardened programming computer/software packages that are updated replacements for the Workmaster computers. For details, please contact the GE Fanuc Hotline at 1-800-GE FANUC (1-800-433-2682), or for international customers, direct dial 804-978-6036.

## IC690ACC900 RS-422/RS-485 to RS-232 Converter

This item is no longer available. The information provided in this manual is for the convenience of those still using this product.

### Note

**GE Fanuc offers the IC690ACC901 Miniconverter kit, documented in the next section of this chapter, as a replacement for the IC690ACC900 Converter.**

This Converter lets you connect a standard RS-232 serial port, such as found on a PC-compatible computer, to the RS-422/RS-485 ports in a Series 90-30 PLC.

If using a Workmaster II computer, this converter eliminates the need to have a Work Station Interface board.

This converter is a small, self-contained device which requires only a cable connection to the Series 90-30 RS-422/RS-485 port on one end and a cable connection to the RS-232 port on the opposite end.

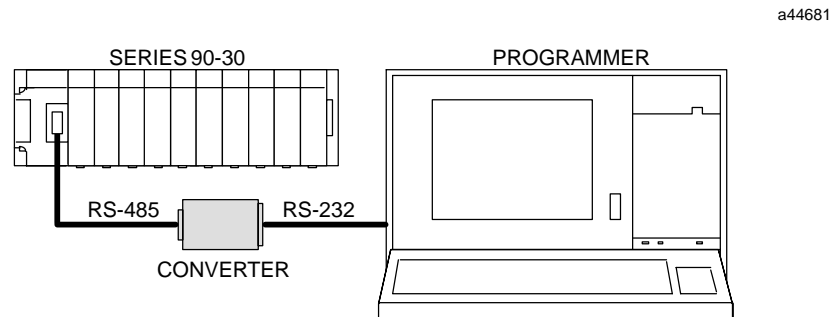

Figure 11-3. Example of IC690ACC900 Converter Connection

The converter operates from a +5 VDC source, which is provided from the PLC backplane +5 VDC bus through the cable connection. The pin assignments for the connections on the cable required for the RS-232 connection are compatible with available PCM compatible serial cables (IC690CBL701, PCM to Workmaster; IC690CBL705, PCM to Workmaster II; and IC690CBL702, PCM to PC-AT). The RS-422/RS-485 connection at the Series 90-30 serial port on the power supply can be made with an available cable (same cable that is used with the Hand-Held Programmer), IC693CBL303.

The three PCM compatible cables (IC690CBL701/702/705) are 10 feet (3 meters) in length, and the HHP compatible cable (IC693CBL303) is 6 feet (2 meters) in length. For those user's who may want to build their own cables, pin assignments and recommended cable types for both cables required for use with the converter are provided in the "Cables" chapter of this manual. For detailed information on this converter, refer to Appendix D.

The IC690ACC903 Port Isolator is available for applications requiring ground isolation or for connection distances up to 4,000 feet. For detailed information, refer to Appendix G.

## IC690ACC901 Miniconverter Kit

The Miniconverter Kit consists of an RS-422 (SNP) to RS-232 Miniconverter, a 6 foot (2 meter) serial extension cable, and a 9-pin to 25-pin adapter. The 15-pin SNP port connector on the Miniconverter plugs directly into the serial port connector on the Series 90-30 power supply, Series 90-70 CPU, or Series 90-20 CPU. The 9-pin RS-232 port connector on the Miniconverter connects to an RS-232 compatible device.

When used with an IBM PC-AT or compatible computer, one end of the extension cable plugs into the Miniconverter's 9-pin serial port connector, the other end plugs into the 9-pin serial port of the computer. The adapter (supplied with kit) is required to adapt the 9-pin serial port connector on the Miniconverter to the 25-pin serial port connector on the GE Fanuc Workmaster II computer, or an IBM PC-XT or PS/2 Personal Computer. The GE Fanuc Workmaster computer requires an additional adapter (*not supplied with kit - please contact your local GE Fanuc PLC distributor*) for use with the Miniconverter.

The Miniconverter is shown in the following figure. For more information on the Miniconverter, refer to Appendix F.

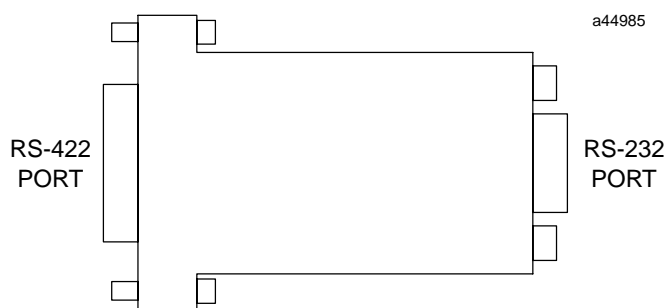

Figure 11-4. IC690ACC901 Series 90 SNP Port to RS-232 Adapter

## IC693PRG300 Hand-Held Programmer (HHP)

Some models of the Series 90-30 PLC can be programmed with the GE Fanuc Hand-Held Programmer (HHP). The HHP uses the Statement List Language. With the HHP, you can develop, debug, and monitor logic programs, monitor data tables, and configure PLC and I/O parameters.

### Note

The user logic program in Series 90-30 CPU numbers 350 and above cannot be viewed or edited with the Hand-Held Programmer. You must use Logicmaster 90-30, Control, or VersaPro programming software with those CPUs.

The HHP connects to the CPU serial port through a 15-pin D-type connector on the Series 90-30 PLC power supply in the CPU baseplate. The physical connection is through a 6-foot (2-meters) long cable (IC693CBL303). This cable also provides power connections to the HHP, and provides a signal that tells the PLC that an HHP is attached. The HHP can be connected or disconnected while the PLC is powered-up. The HHP does not require communications parameter configuration in order to communicate with a PLC. This makes it useful for troubleshooting a communications problem between a PC and the PLC.

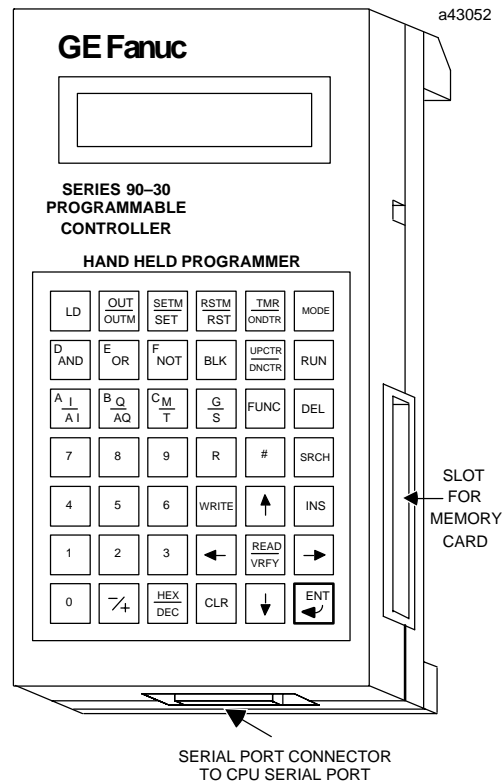

Figure 11-5. Hand-Held Programmer for the Series 90-30 PLC

## HHP Features

The keypad for the HHP is a sealed type with tactile feedback, and has 42 keys, arranged in a matrix of six keys across by seven keys down. It has a two-line by 16 character LCD display screen.

## HHP Memory Card (IC693ACC303)

The HHP has a slot for a removable memory card, which provides a means for non-volatile, off-line program storage and restoration. The memory card can only be used with CPU numbers 311 through 341. CPU numbers 350 and above do not support either the HHP or the memory card. The memory card plugs into a connector accessed through a slot on the lower right side of the HHP (see previous figure).

## HHP Modes of Operation

The HHP functionality is basically divided into four modes of operation which are selected through a key sequence on the keypad. These modes are: *program* mode, *protection* mode, *data* mode, and *configuration* mode.

### **Program Mode:**

Allows you to create, change, monitor, and debug Statement List logic. This mode also allows read, write, and verify functions with the memory card, EEPROM, or flash memory.

### **ProtectionMode**

Provides a way to control access to (protection of) certain PLC functions, including program logic, reference data, and configuration information. The use of this function is optional; however, it is convenient in that it allows you to protect parts of the PLC system from accidental or deliberate modification. Protection is provided through four levels of passwords assigned by the user.

### **DataMode**

Allows you to view, and optionally alter values in various reference tables. Several display formats can be selected in which to view this data: binary, hexadecimal, signed decimal, and timer/counter.

### **ConfigurationMode**

Allows you to define the types of I/O modules that are installed or will be installed in the PLC system. You can also assign I/O module addresses to these modules. This feature is convenient in that it allows you to write and test logic programs using discrete references assigned to I/O modules that are not yet installed. In this mode, you can also configure CPU data, such as real-time clock, coil check, and HHP characteristics, such as keyclick on or off.

## Documentation

For detailed information about the Hand-Held Programmer, refer to GFK-0402, the *Series 90-30/20/Micro Hand-Held Programmer User's Manual*.

## IC693PIF301/400 Personal Computer Interface (PCIF) Cards

These two Personal Computer Interface cards (PCIF and PCIF2) provide an alternative method of controlling Series 90-30 I/O. Either card can be used in place of a Series 90-30 PLC CPU. These ISA-compatible cards can be installed in any IBM-PC/AT ISA bus computer. The cards are implemented using computer language software (for example, C), or PC control software, such as Total Control Products' FrameworkX Automation Software.

Table 11-1. Personal Computer Interface Card Comparison Table

| ITEM                                    | PCIF                                 | PCIF2                                 |
|---|--------------------------------------|---------------------------------------|
| Catalog Number                          | IC693PIF301                          | IC693PIF400                           |
| Amount of I/O controlled                | 1,280 bytes                          | 25,886 bytes                          |
| Number of Series 90-30 racks controlled | Up to four Expansion or Remote racks | Up to seven Expansion or Remote racks |
| Slot requirement                        | IBM-PC/AT ISA, 8-bit, half size      | IBM-PC/AT ISA, 16-bit, full size      |
| Documentation                           | GFK-0889 (IPI)                       | GFK-1540 (data sheet)                 |

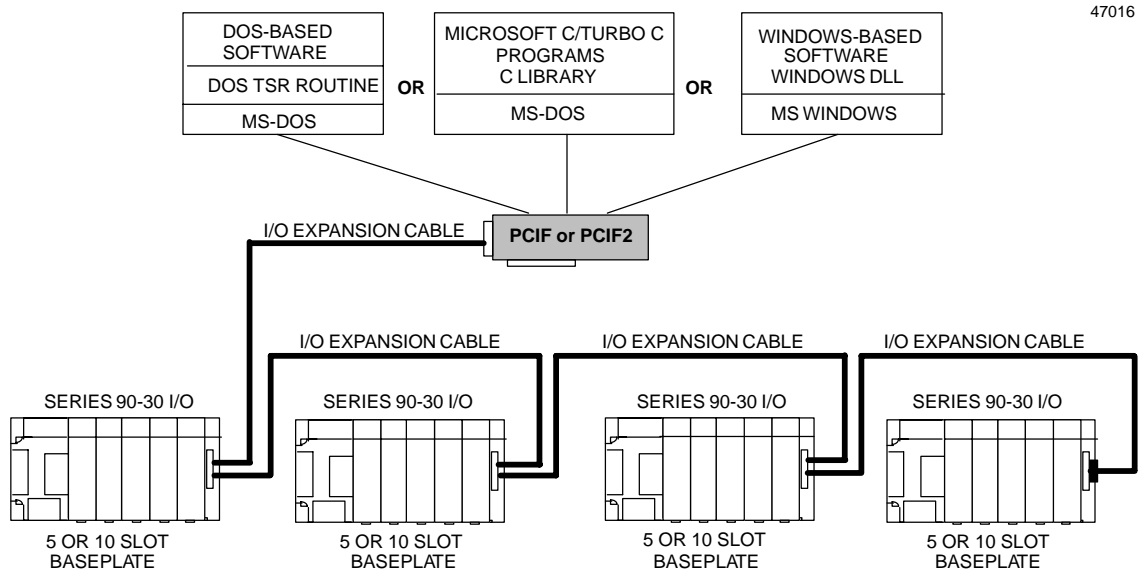

47016

Figure 11-6. Example of PCIF Interface to Series 90-30 I/O

Both of these PCIF cards have a 25-pin I/O expansion connector that connects to standard Series 90-30 Expansion and Remote baseplates (see the "Baseplates" chapter) via I/O expansion cabling. Remote racks can be located up to 700 feet ( 213 meters) and Expansion racks up to 50 feet (15 meters) from the personal computer. Several standard prewired I/O expansion cables are available from GE Fanuc. Alternately, custom length cables can be built. Please refer to the "Cables" chapter of this manual for information on standard and custom I/O expansion cables.

These cards also provide connections to an internal watchdog-supervised RUN output relay contact. This contact is closed under normal operating conditions, but opens if the computer or software application fails, which makes it useful for interfacing with external safety circuits.

These cards support all Series 90-30 discrete and analog I/O modules (except 16-channel analog modules). A variety of *smart* modules from Horner Electric, Inc. are also supported.

A *C Language Interface* software product, available from Horner Electric, works with both Borland Turbo C and Microsoft C. The source code for this interface is available from Horner Electric (catalog number HE693SRC844).

### **Documentation**

Documentation for these cards is noted in the table above. Additional user's documentation is available from Horner Electric, Inc.

## IC655CCM590 Isolated Repeater/Converter

**This item is no longer available. The information provided in this manual is for the convenience of those still using this product.** This product also went by an earlier catalog number, IC630CCM390, and is nicknamed, the “Brick.” Details can be found in Appendix E.

### Note

**In most applications, the newer IC690ACC903 Port Isolator can be used in place of the IC655CCM590 Isolated Repeater/Converter.**

## IC690ACC903 Port Isolator

This product was produced to fill the need created when the IC655CCM590 Isolated Repeater/Converter became obsolete. It provides 500 volts of isolation between connected RS-485 ports. It can be used in either single or multi-drop applications, and has a cable length working distance of 4,000 feet (1,219 meters). It is physically smaller than the IC655CCM590. For details about this product, please refer to Appendix G.

# Chapter *System Design*

## 12

[efesotomasyon.com](http://efesotomasyon.com)

---

---

### Introduction

This chapter does not pretend to cover every possible aspect of designing a Series 90-30 system, but it does provide you with basic product selection guidelines and with help in finding the information you need. You will also find the *GE Fanuc Automation Solutions Catalog* to be a valuable tool for system design.

### Step 1: Planning Your System

Planning is an important part of designing a system. The better you plan the system, the less trouble you will have installing and implementing it. The following list discusses some basic things to know or have when planning your system:

- **Expectations.** If a new system, what is it expected to do? If retrofitting an existing system, what does it do now, and what is it expected to do after it is retrofitted.
- **Specifications (preferably in writing).** These include such things as operating environment information, speed, accuracy, repeatability, size, conformance to standards, cost restrictions, time requirements, etc.
- **Technical documentation.** If retrofitting existing equipment, you can refer to its documentation (layout drawings, schematics, etc.). If the documentation is lost, perhaps a copy is available from the manufacturer. Additional information may be gathered from discussions with the equipment operators and maintenance technicians. For a new design, there are probably mechanical or process drawings of the equipment.

### Step 2: Determining I/O Requirements

This step comes next because other Series 90-30 component choices are dependent on the number of I/O points required. In particular, the number of modules required, and their locations, determines what type and how many baseplates are needed and also is a major factor in CPU selection. Note that there are some restrictions on the maximum number of certain types of modules (Analog I/O and Option) that can be supported in one PLC system. See the table “Maximum Number of Modules Per System” for data.

- To start, determine how many I/O points, both analog and discrete, are needed for your system. If retrofitting an existing system, use the schematic diagrams for the system. If designing a new system, use the mechanical drawings or specifications to determine what inputs and outputs are needed. List these on a piece of paper (or on

your drawing software screen). Separate them into four type, to correspond to the four types of modules you will use: Discrete Input, Discrete Output, Analog Input, Analog Output. If there are any special requirements, such as fast response, etc., make a note of them on the page. Also, if parts of your system are physically separated from other parts, meaning you will probably be using Expansion or Remote Racks, create a separate list for each location.

- When you have finished developing your I/O lists, determine how many I/O modules of each type you need. Although there is an abbreviated "I/O Modules" chapter in this manual, you should refer to publication GFK-0898, *Series 90-30 PLC I/O Module Specifications User's Manual* for complete details. If you are using Remote Racks, create a separate list for each location.

### Additional I/O Module Selection Factors

- **Voltage/Current Requirements** – A wide variety of possible operating voltage and current requirements can be met with Series 90-30 I/O modules.
- **Positive or Negative Logic** – The applicable type can be selected to match sink or source signal requirements. See GFK-0898, *Series 90-30 PLC I/O Module Specifications User's Manual*, for details.
- **Isolation Requirements** – Isolated discrete I/O and relay output modules may be selected to meet isolation requirements.
- **Hard Contact Requirements** – Relay output modules can be applied.
- **Cost** – The selection of certain modules can possibly reduce the number of racks required in your system. For example, 32-point discrete I/O modules can save rack space compared to lower density modules.
- **Standardization** – Sometimes a company will standardize on particular types of modules to simplify training or stocking of spare parts.
- **Response Time and Noise immunity** – I/O modules have different response time and noise immunity capabilities. These factors should be considered when selecting I/O modules. In general, higher response speed is usually attained at the sacrifice of some noise immunity. Therefore, if high response speed is not a requirement, it would be better to select a slower I/O module that has higher noise immunity. However, all I/O modules, regardless of their response time rating, have a reasonable level of noise immunity. Note that the IC693APU305 I/O Processor Option module, with its 500 us update time, can handle I/O signals that are too fast for the CPU to handle directly (see GFK-1028, *Series 90-30 I/O Processor Module User's Manual*).

## Step 3: Selecting Option Modules

There are several application requirements that determine Option module selection. However, note that there are some restrictions on the maximum number of certain types of modules (Analog and Option) that can be supported in one PLC system. See the table "Maximum Number of Modules Per System" for data.

- **Interfacing with a Particular Protocol or Standard** – CCM, Ethernet, FIP, Genius, RTU, SNP, etc.
- **Interfacing with GE Fanuc CNC controls**– Use the IC693BEM320 and IC693BEM321 I/O Link modules.

- **Distance** – Genius controller modules can communicate at distances up to 7,500 feet (2,286 meters). Serial communications using the RS-485 standard can cover up to 4,000 feet (1,219 meters). FIP networks are rated for 1,640 feet (500 meters). Modules with serial ports communicating via modems and telephone lines or satellite links can cover unlimited distances.
- **High speed inputs** – The IC693APU300 High Speed Counter can be used with encoders to count high speed pulse trains. The IC693APU305 I/O Processor module is an intelligent module that can satisfy high speed input and output requirements independent of the PLC scan.
- **Motion needs** – The IC693APM301/302 and IC693DSM302 (and the future IC693DSM314) are motion control modules that work with servo motor controllers and other motion devices. The IC693APU300 High Speed Counter module can count high speed pulses from encoders for use in measuring motion-related data.
- **Temperature control** – The IC693TCM302 Temperature Control Module (TCM) has thermocouple inputs and PWM outputs.
- **Extended features** – Where there are two or more Option module choices for a particular application, often an extended feature requirement determines which one to choose. For example, there are two Ethernet choices, the IC693CMM321 and the IC693CPU364, but only the IC693CPU364 has Ethernet Global Data (EGD) capability. Another example: There are three Genius controller modules, the IC693CMM301 Genius Communications Module (GCM), the IC693CMM302 Enhanced Genius Communications Module (GCM+), and the IC693BEM331 Genius Bus Controller module (GBC). While all three are capable of basic Genius communications, only the Genius Bus Controller module can control Genius Blocks.
- **Remote or distributed I/O needs** – One distributed I/O solution is the use of GE Fanuc’s Genius Blocks, which can be mounted at the point of use and connected with a PLC’s Genius Bus Controller (GBC) module via a twisted-pair cable. The Genius Bus Controller is the only Series 90-30 module that can control Genius Blocks. Other modules (GCM, GCM+) can read input data broadcast by Genius Blocks, but cannot send commands to them. By selecting the applicable bus interface unit (BIU), you can use GE Fanuc Field Control distributed I/O to interface to Series 90-30 WorldFIP, Profibus, and Genius buses.
- **State Logic** – These products allow “Natural Language programming” as an alternative to ladder logic. This makes program creation, documenting, and editing easier for those not trained in ladder logic programming. Industries that are required by law to thoroughly document any changes to their system find State Logic to be especially useful.
- **Cost** – Sometimes an Option module choice can be made based on the basis of cost. This is the case where either of two modules are capable of filling a need. For example, if you only need the capabilities of the IC693CMM302 Enhanced Genius Communications Module (GCM), you wouldn’t have to purchase the more capable, but more expensive, IC693BEM331 Genius Bus Controller module (GBC).
- **Performance** – Higher data transfer rate or amount of data often dictates which Option module will be used. For example, the IC693CMM302 Enhanced Genius Communications Module can transmit and receive many times more data than the IC693CMM301 Genius Communications Module, and it transfers data to the PLC CPU at a faster rate. A comparison table for these two modules is found in Appendix A of GFK-0695.

- **Standardization** – Sometimes a company will standardize on particular types of modules to simplify training or stocking of spare parts.
- **Display requirements** – Several options are available for interfacing with GE Fanuc Human to Machine Interface (HMI) devices.
- **Third-party solutions** – Many automation solutions result from combining GE Fanuc product with third-party products. There are dozens of third-party modules and other products that work with GE Fanuc PLC products. Examples of third-party Series 90-30 modules are Profibus, DeviceNet, SDS, LonWorks, Interbus-S, RTU/Modbus, ASCII Basic, RTD, and Millivolt/Strain Gauge Input. Contact your GE Fanuc distributor for further information, or check the GE Fanuc Web site for third-party product information and links.

## Step 4: Selecting a CPU

Once you have determined how many and what type of I/O and Option modules you require, you can select a CPU. Many of the factors that apply to selecting Option modules, such as performance, cost, standardization, etc. also apply to selecting a CPU. Details on CPU capabilities are found in the “CPUs” chapter.

- **Number of modules required by the system** – Embedded CPUs come in 5-slot or 10-slot sizes and they do not support Extension or Remote baseplates. Therefore, if a system requires only a few modules, these may be an option. If more than 10 modules are required, you must select a Modular CPU. The CPU331–341 CPUs support up to 5 total baseplates, and the CPU350–364 CPUs support up to 8 total baseplates. If you need more than 49 total Option and I/O modules, you will need to use one of the CPU350–364 group of CPUs.
- **Modules with Quantity Restrictions**– Many modules are restricted as to how many may be used in one system. This number also varies by CPU. For example, in the case of an 8-channel Analog Output module, the maximum number per system is:
  - 4 if using a 311, 313, or 323 CPU
  - 8 if using a 331, 340, or 341 CPU
  - 79 if using a 360–364 CPU

Please see the section “Maximum Number of Modules Per System” table for data.

- **Types of Option Modules** – The PCM, ADC, CMM, and SLP modules can only work in a Modular CPU baseplate. Use of these modules would, therefore, rule out the use of Embedded CPUs (311, 313, 323). See the section “Location of Modules in the PLC Racks” for more information.
- **Performance** – as shown in the “CPUs” chapter, the CPU350 – 364 CPUs use a more powerful microprocessor than the lower numbered CPUs. For applications where higher performance is required, one of these would be a good choice. For math-intensive applications, the CPU352, with its built-in math coprocessor, would give the best performance. For Ethernet applications, the CPU364 with its built-in Ethernet interface, provides faster performance than separate CPU and Ethernet modules because they have to communicate over the PLC backplane, which is slower than the CPU364’s internal path. For serial communications, the CPUs 351, 352, and 363 (using Ports 1 and 2) perform faster than an IC693CMM311 module.
- **Extended features** – The IC693CPU364 has a built-in Ethernet interface which would eliminate the need for a separate Ethernet module. This would save a PLC

slot. The CPU351, CPU352, and CPU353 each have two additional built-in serial ports which eliminate the need for a separate serial communications Option module. The CPUs 350–364 have extra features and capabilities that the other CPUs do not have such as, Floating Point Math, Sequential Event Recorder, and Memory Protect Key Switch. Also, CPUs 351–364 have larger total memory size, as well as configurable analog and register memory.

- **Memory requirements** – The CPU351–364 CPUs have configurable analog and register memory. This makes them more capable of meeting the needs of (1) Option modules that require this type of memory and (2) user programs that require larger amounts of register or analog memory. The CPU360 does not have configurable memory and has a lower base memory size than the CPU351–364 CPUs. The CPU360–364 CPUs have standard Flash PROM for user data storage. This is not available in some of the other CPUs. See the “CPU Firmware and PROM Configurations” table in the “CPUs” chapter for details.
- **Expandability and Upgradeability** – The Embedded CPUs do not support Expansion or Remote racks and do not allow changing CPU type. Therefore, they have limited expandability or upgradeability options. Modular CPUs can be upgraded to more powerful CPUs. The type of modular CPU determines whether a system can have a total of 5 or 8 baseplates, which can have a direct bearing on the future expansion capabilities of a system. For example, if you only need 49 total Option and I/O Modules, you could use one of the CPU331–341 CPUs. However, you would be at the maximum module limit and would not be able to add any more to the system without changing the CPU. If you used, instead, one of the CPU360–364 CPUs, you could later add up to 30 more modules while keeping the same CPU. This would simplify expanding the system.
- **Cost** – If some of the other factors such as performance or extended features are not major issues, one of the lower cost CPUs can be applied. However, sometimes purchasing a more expensive CPU with extended features can be less costly than purchasing a lower cost CPU and an additional Option module to cover the feature needed. Besides the direct cost of the modules, using the single CPU would save a PLC slot, which could help eliminate the need for, and cost of, an extra Baseplate, Power Supply, I/O Bus Expansion Cable, etc. Since prices are subject to change, it would not be practical to give an example of this. Please check with your distributor for current pricing information.
- **Display requirements** – The CPU351, CPU352, CPU363, and CMM311 have serial ports that are often used to communicate with Human to Machine Interface (HMI) or Operator Interface (OI) devices.
- **Time of day (TOD) clock requirements** – The Embedded CPUs do not have one, the Modular CPUs do.
- **System size limitation** – If you are close to the maximum number of modules limitation of your system, you can use modules that have dual functions to conserve rack slots. For example, the CPU364 has CPU and Ethernet communications capability in one module. The CPUs 351, 352, and 363 have CPU and Serial Communications capability in one module. There are discrete and analog combination I/O modules that provide a limited number of both inputs and outputs in one module. Also, the 32-point discrete I/O modules conserve rack slots compared with lower density (16-point and less) I/O modules. You may also be able to use Genius Blocks or Field Control distributed I/O to accommodate the need for additional I/O, since these do not require a PLC slot; they communicate with the

PLC over a communications bus. Genius Blocks communicate over a Genius Bus, and Field Control can communicate over Genius, FIP, or Profibus busses.

- **Protection against unauthorized changes.** CPUs 360 – 364 have a keylock switch that can be locked to protect against unauthorized changes to the PLC. CPUs 311 – 341 do not have a keylock switch. However, all CPUs have the capability of password protection for the application program.

## Step 5: Selecting Baseplates

The requirements determined in the previous steps will largely dictate what baseplates to select. Please refer to the “Baseplates” chapter for additional details.

- **Embedded CPU baseplate** – If the previous selections dictate the use of an Embedded CPU, you have three choices. The CPU311 and CPU313 are 5-slot sizes, and the CPU323 is a 10-slot size. The CPU311 has 6K Bytes of memory and the CPU313 has 12K Bytes.
- **Modular CPU Baseplate** – If you need a modular CPU, you must use a Modular CPU baseplate. There can be only one CPU baseplate per system. There are just two types, 5-slot and 10-slot. If you only need a 5-slot size, you may want to consider whether the extra slots that a 10-slot size would provide would be advantageous for possible future expansion. On the other hand, the 5-slot size requires less space.
- **Expansion and Remote baseplates** – These also come in 5-slot and 10-slot sizes. In general, it is best to use Expansion baseplates where possible instead of Remote baseplates because of the better speed performance of the Expansion baseplates. Where a total cable distance of over 50 feet is required, Remote baseplates must be used. In cases where you only need a 5-slot size, you may want to consider whether it would be advantageous to use a 10-slot size in order to have open slots for future expansion. That factor should be weighed against the fact that the 5-slot size requires less space and costs less.
- **Physical size** – For locations with size limitations, one or more 5-slot baseplates may be a good choice. See the “Baseplates” chapter for baseplate dimensions and clearance requirements.
- **Number of Modules Required** – The number of modules need at each location will have a bearing on the sizes of racks required. You may choose to use a smaller rack (5-slot), if possible, to save cost and space. However, as noted below, a larger rack (10-slot) with unused slots will leave some room for future expansion, if desired.
- **Expandability** – For future expansion, you might wish to leave some unused slots in certain baseplates.

## Step 6: Selecting Power Supplies

The following factors will affect your Power Supply selection decisions. See the “Power Supplies” chapter for additional details.

- **Power capacity** – All Series 90-30 Power Supplies have three individual outputs: +5VDC, +24VDC (Relay), and +24VDC (Isolated). Although all of these Power Supplies are rated at 30 Watts maximum total output, the rating of the +5VDC output varies from supply to supply, as shown in the following table. For applications requiring heavy loading of the +5VDC supply, choose one of the “High Output” power supplies: IC693PWR330 or IC693PWR331.

- **Input voltage** – As seen in the next table, nominal input voltage choices are 24VDC, 48VDC, 120VAC, 125VDC, and 240VAC.

Table 12-1. Power Supply Feature Comparison Table

| Catalog Number | Load Capacity | Nominal Input             | Output Capacities (Voltage/Power †) |                              |                           |
|----------------|---------------|---------------------------|-------------------------------------|------------------------------|---------------------------|
|                |               |                           | +5 VDC                              | +24 VDC Isolated             | +24 VDC Relay             |
| IC693PWR321    | 30 Watts      | 100 to 240 VAC or 125 VDC | +5 VDC<br>15 watts                  | +24 VDC Isolated<br>20 watts | +24 VDC Relay<br>15 watts |
| IC693PWR330    | 30 Watts      | 100 to 240 VAC or 125 VDC | +5 VDC<br>30 watts                  | +24 VDC Isolated<br>20 watts | +24 VDC Relay<br>15 watts |
| IC693PWR322    | 30 Watts      | 24 or 48 VDC              | +5 VDC<br>15 watts                  | +24 VDC Isolated<br>20 watts | +24 VDC Relay<br>15 watts |
| IC693PWR331    | 30 Watts      | 24 VDC                    | +5 VDC<br>30 watts                  | +24 VDC Isolated<br>20 watts | +24 VDC Relay<br>15 watts |

† Total of all outputs combined cannot exceed 30 watts.

## Reducing PLC Module Count by Using Other GE Fanuc Products

If system size limitations (more than 79 modules are needed) are a problem in a system using Remote racks, a possible solution could be the use of GE Fanuc Genius Blocks, Field Control, or VersaMax products. These distributed I/O devices can be used instead of Remote racks in remote locations in some cases, and their use would not add to the Series 90-30 module count.

### Genius Blocks

These are intelligent distributed I/O blocks that are panel-mounted at the point of use. They communicate with a Genius Bus Controller (GBC) module in the PLC via a shielded, twisted-pair cable. They are not included in the PLC module count, but do require I/O memory allocation. A single GBC module in a PLC rack can control up to 31 Genius Blocks. Genius Blocks come in discrete and analog I/O, high speed counter, RTD, and thermocouple interface types. For more information on using Genius Blocks, see GEK-90486-1, *Genius I/O System and Communications User's Manual*, and GEK-90486-2, *Genius I/O Discrete and Analog Blocks User's Manual*.

### Field Control

These are intelligent distributed I/O units that mount at the point-of-use on a 35mm x 7.5mm DIN-rail. They can communicate over Genius, FIP, or Profibus buses. They are not included in the PLC module count, but do require I/O memory allocation. A Field Control unit consists of a Bus Interface Unit (BIU) that interfaces to the applicable bus, from one to eight I/O modules, and cabling. I/O modules come in various discrete, analog, and RTD types. A local logic processor module (MFP) is also available. For further information on Field Control, see the following:

- GFK-0826, *Field Control Distributed I/O and Control System I/O Modules User's Manual*
- GFK-0825, *Field Control Genius Bus Interface Unit User's Manual*
- GFK-1175, *Field Control FIP Bus Interface Unit User's Manual*
- GFK-1291, *Field Control Profibus Bus Interface Unit User's Manual*

## VersaMax

VersaMax I/O modules can be used as distributed I/O, communicating with a Series 90-30 PLC over one of three bus types: Genius, Profibus, or Device Net. This arrangement would require an Option module for the desired bus type in the Series 90-30 PLC as well as the applicable Network Interface Module in the VersaMax system. For more information on the VersaMax products, please see GFK-1504, *VersaMax Modules, Power Supplies, and Carriers Manual*.

## Designing For Safety

A good design should not only function properly and efficiently, but must also **protect personnel and equipment from harm**. Although some basic guidelines are found in the “Installation” chapter of this manual, it is not possible to cover every aspect of safety because of the diversity of applications. Additionally, it is not practical for this manual to try to cover all the possible codes and regulations that may apply to your locality or type of equipment. **You have the ultimate responsibility to consult applicable safety codes for your locality, or that pertain to the particular type of equipment you are designing, and ensure that your design complies with these standards.** In the United States, the National Electric Code (NEC) has been adopted by many localities. The United States Occupational Safety and Health Administration (OSHA) regulations also contain many safety regulations that apply to all industrial equipment in the United States. In the absence of local regulations, the NEC and OSHA regulations should be followed when designing your system, in addition to the information contained in this manual. OSHA regulations can be accessed on-line at [www.osha.gov](http://www.osha.gov). Some key safety issues are outlined below:

### Protection From Electrical Shock

Proper wiring design, including grounding and circuit protection issues, should be followed. Personnel should be prevented from accidentally coming in contact with hazardous voltages. Also, unauthorized personnel should be prevented from gaining access to high voltage cabinets and panels. Interlock circuits are often used for this purpose.

### Fire Prevention

The guidelines in the NEC and OSHA regulations protect against fires, especially those caused by faulty electrical design.

### Protection From Mechanical Hazards

Personnel should be protected from physical hazards, such as moving mechanisms like conveyors or index tables or mechanical pinch points. The use of interlocked safety gates, light curtains, safety mat switches, dual hand buttons, physical barriers (guards), etc. can be used for this purpose. See the applicable section of the OSHA regulations for details.

### Protection From Electrical Failure

In the event of a system component failure, the design should be an acceptable “fail-safe” one in which the failure does not cause a safety hazard such as a runaway

condition or a disabling of emergency stop circuits. Emergency stop and other safety circuits should consist of hard-wired components that tend to fail in a harmless manner.

For example, in a Master Control Relay (MCR) circuit, use series-wired, normally closed Emergency Stop pushbutton switches and interlocks to control an electro-mechanical Master Control Relay (see next figure). This relay should directly disable motor starters, PLC output circuits, etc. This type of circuit tends to fail “open,” which disables the equipment. For example, if a wire breaks or a contact wears out, the circuit opens and the MCR drops out. If solid state devices fail, they tend to fail “shorted,” which in the case of PLC output circuits would cause the controlled device to turn on or stay on.

In the circuit below, the MCR is an electro-mechanical relay. It is energized by the application of power to its solenoid coil which magnetically pulls the contacts to their energized states. When de-energized, the contacts move to their normal, at rest states by the pull of a mechanical spring. When the Reset pushbutton is pressed, and if all four of the E-Stop and Gate switches are closed, the MCR relay will energize and “latch” in the energized state through its MCR contact in parallel with the Reset pushbutton. Its other MCR contact applies power to the motor starter and PLC output circuits. If any one of the E-Stop or Gate switches opens, or if a wire breaks in this circuit, or if the MCR coil becomes defective, MCR will de-energize and open the circuit to the motor starters and PLC output circuits.

As shown, the PLC’s main power and input circuits are not controlled by the MCR since they do not directly control any outputs. Keeping these circuits energized is desirable because this allows the PLC to continue gathering data, recording fault information, and controlling communications, even if its Output module outputs are disabled by the MCR.

If an additional margin of safety were desired, two MCR relays could be used. Their coils would be wired in parallel, their normally open contacts wired in series, and their normally closed contacts wired in parallel. This would help guard against the possibility of a “welded contact” on a single MCR relay.

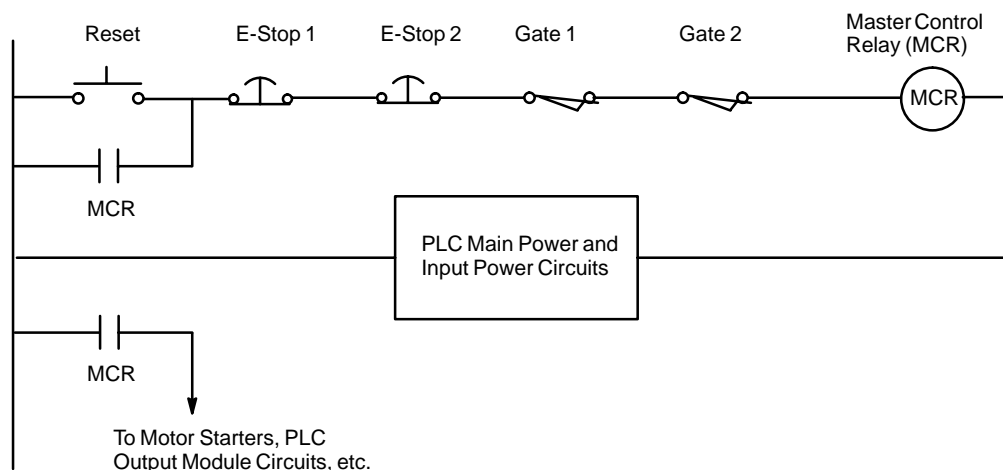

Figure 12-1. Hard-Wired MCR Circuit Example

## Protection From Design Changes or Overrides

Only authorized personnel should be allowed to make changes that could impact the safe operation of the equipment. Passwords and lockout circuits may be used to accomplish this. Some Series 90-30 CPUs have keylock switches to protect against program changes (see “CPUs” chapter for keylock switch details).

## Safety Documentation

- **PLC Program Documentation.** Thorough documentation will help you and others who work on the equipment remember and understand how the safety circuits and features work. (In some industries, applicable regulations may require this type of documentation.) The PLC programming software gives you extensive documentation abilities.

For example, you can create Nicknames such as “PSTOP,” Descriptions such as “Program Stop Coil,” and Comments such as “This coil is used to stop the program cycle, but it does not turn off power to the main hydraulic circuit. However, if the operator opens the safety gate, the Safety Gate Interlock switch will open and shut off the hydraulic pump.” These Nicknames, Descriptions, and Comments become part of the PLC program and can be viewed with the applicable software.

As an alternative to ladder logic programming, the State Logic programming language makes it easier to document PLC program design because it uses “Natural Language” expressions instead of ladder logic symbols.

- **Electrical and mechanical prints** should contain notations pertaining to safety issues.
- **Written operating and maintenance instructions** as well as training should be provided to operators and maintenance personnel. These should address any applicable safety issues.

## Guarding Against Unauthorized Operation

Keylock switches and passwords are frequently used for this purpose.

## Labeling, Guarding, and Lighting Issues

- **Labeling.** Operator devices such as pushbuttons, switches, or on-screen (software) buttons should be clearly labeled as to their function.
- **Guarding.** Operator devices should be guarded, where applicable, to prevent them from being activated accidentally. Recessed pushbutton designs or pushbuttons with surrounding guard rings might help prevent the pushbutton from being depressed if, for example, a tool were dropped or laid upon it. Mounting pushbutton stations to vertical surfaces also may help avoid this problem.
- **Lighting.** Illumination levels in the working area should be adequate so that all labels can be clearly seen.

## Equipment Accessibility Issues

The equipment should be laid out so as to give operators sufficient room to perform their tasks safely. Also, sufficient clearance should be provided so that maintenance personnel have safe access to electrical panels, control boxes, etc. These minimum clearances are specified in the NEC and OSHA requirements.

## Number of Modules Per Series 90-30 PLC System

The following table lists the maximum number of each type of I/O and option modules that can be installed in a Series 90-30 PLC system. The number of modules that can be installed in a system depends on several factors, including available references for each CPU model, the current rating for each module to be installed in the system, and other installed modules. Before installing modules in a baseplate, verify that the total current rating of all of those modules does not exceed the power rating of the power supply.

**Table 12-2. Maximum Number of Modules Per System**

| Module Type   | CPU<br>Model B11/313/323   | CPU<br>Model B31/340/341                                | CPU<br>Model 350 - 364 |
|---|--|---|------------------------|
| Input and Output, Discrete                                  | 5 (5-slot baseplate)<br>10 (10-slot baseplate)   | 49 (Model 31/340/341)                                   | 79                     |
| Input Module, Analog, 4-Channel                             | 5 (5-slot baseplate)<br>8 (10-slot baseplate)  | 40  | 64                     |
| Input Module, Analog, 16-Channel                            | 4  | 8 (Model 331)<br>12 (Model 340/341)                     | 51                     |
| Output Module (Voltage), Analog, 2-Channel                  | 5 (5-slot baseplate)<br>6 (10-slot baseplate)  | 16 (Model 331)<br>30 (Model 340/341)                    | 48                     |
| Output Module (Current), Analog, 2-Channel                  | 3 (5-slot baseplate)<br>3 (10-slot baseplate)  | 15 (Model 331)<br>15 (Model 340/341)                    | 24                     |
| Output Module, Analog, 8-Channel                            | 4  | 8 (Model 331)<br>32 (Model 340/341)                     | 79                     |
| Combination Input/Output Module, Analog<br>4-Ch In/2-Ch Out | 5 (5-slot baseplate)<br>10 (10-slot baseplate)   | 21 (Model B31/40/341)                                   | 79                     |
| Programmable Coprocessor Module                             | n/a  | 4   | 4                      |
| Alphanumeric Display Coprocessor Module                     | n/a  | 4   | 4                      |
| Communications Control Module                               | n/a  | 9   | 9                      |
| State Logic Processor Module                                | n/a  | <i>Refer to the State Logic User's Guide, GFK-0726.</i> |                        |
| Genius Communications Module (1)                            | 1  | 1   | 1                      |
| Enhanced Genius Communications Module (1)                   | 2  | 2   | 2                      |
| High Speed Counter  | 4 (5/10-slot baseplate)  | 8 (Model 331)<br>32 (Model 340/341)                     | 79                     |
| I/O Link Interface Module                                   | 5 (5/10-slot baseplate)  | 49  | 79                     |
| I/O Processor Module  | 2 (5-slot baseplate)<br>4 (10-slot baseplate)  | 8 (Model 331)<br>16 (Model 340/341)                     | 64                     |
| Genius Bus Controller (2)                                   | 8  | 8   | 8                      |
| Ethernet Interface Module                                   | <i>Refer to the Series 90-30 TCP/IP Ethernet Communications User's Manual, GFK-1084 for details.</i> |   |                        |
| Motion Mate APM300 Module                                   | <i>Refer to the Motion Mate APM300 User's Manuals, GFK-0840 or GFK-0781 for details.</i>             |   |                        |
| Motion Mate DSM302 Module                                   | <i>Refer to the Motion Mate DSM302 User's Manual, GFK-1464, for details.</i>                         |   |                        |
| Motion Mate DSM314 Module                                   | <i>Refer to the Motion Mate DSM314 User's Manual, GFK-1742, for details.</i>                         |   |                        |
| Temperature Control Module                                  | <i>Refer to the Temperature Control User's Manual, GFK-1466 for details.</i>                         |   |                        |
| Power Transducer Module                                     | <i>Refer to the Power Transducer Module User's Manual, GFK-1734, for details.</i>                    |   |                        |

- (1) The Enhanced Genius Communications Module and the Genius Communications Module cannot be installed in the same PLC baseplate; however, both modules can be present on the same bus.  
 (2) Refer to GFK-1034, *Series 90-30 Genius Bus Controller User's Manual* for details.

## Calculating Power Supply Loading

The load placed on a power supply in a Series 90-30 PLC baseplate is the sum of the internal and external loads placed on it by all of the hardware components in the baseplate (backplane, modules, etc.), as well as external loads connected to the Isolated + 24 VDC supply. Use of the Isolated +24 Volt power supply output is optional; however, this output can be used to drive a limited number of input devices. The maximum total power output rating of the Power Supplies is 30 watts; however, the individual +5VDC outputs can be rated for either 15 or 30 Watts, depending on the Power Supply catalog number. See Table 12-1, "Power Supply Feature Comparison Table," for details.

### Load Requirements for Hardware Components

The following table shows the DC load required by each module and hardware component. All ratings are in milliamps (except where noted). Input and Output module current ratings are with all inputs or outputs on. Three voltages are listed in the table:

- +5 VDC provides primary power to operate most internal circuits
- + 24 VDC Relay Power provides power for circuits that drive the relays on Relay modules
- +24 VDC Isolated provides power to operate a number of input circuits (input modules only), and any external circuits connected to the 24 VDC Output terminals on the power supply terminal strip.

Note that the figures listed in the following table are maximum (worst case) requirements, not typical requirements.

Table 12-3. Load Requirements (in milliamps)

| Catalog Number | Description  | +5 VDC      | +24 VDC Relay Power | +24 VDC Isolated |
|----------------|--|-------------|---------------------|------------------|
| AD693SLP300    | State Logic Processor Module   | 425         | -                   | -                |
| IC693ACC300    | Input Simulator, 8/16 Points   | 120         | -                   | -                |
| IC693ACC307    | Expansion Bus Termination Plug   | 72          | -                   | -                |
| IC690ACC900    | RS-422/RS-485 to RS-232 Converter  | 170         | -                   | -                |
| IC690ACC901    | RS-422 (SNP) to RS-232, Miniconverter Kit (Version A)<br>(version B, or later)   | 150<br>100  | -<br>-              | -<br>-           |
| IC693ADC311    | Alphanumeric Display Coprocessor Module  | 400         | -                   | -                |
| IC693ALG220    | Analog Input, Voltage, 4 Channel   | 27          | -                   | 98               |
| IC693ALG221    | Analog Input, Current, 4 Channel   | 25          | -                   | 100              |
| IC693ALG222    | Analog Input, Voltage, High Density (16 Channel)                                 | 112         | -                   | 41               |
| IC693ALG223    | Analog Input, Current, High Density (16 Channel)                                 | 120         | -                   | -                |
| IC693ALG390    | Analog Output, Voltage, 2 Channel  | 32          | -                   | 120              |
| IC693ALG391    | Analog Output, Current, 2 Channel  | 30          | -                   | 215              |
| IC693ALG392    | Analog Current/Voltage Output, 8 Channel   | 110         | -                   | -                |
| IC693ALG442    | Analog Current/Voltage Combination 4 Ch In/2 Ch Out                              | 95          | -                   | 129              |
| IC693APU300    | High Speed Counter   | 250         | -                   | -                |
| IC693APU301    | Motion Mate APM300, 1-Axis   | 800         | -                   | -                |
| IC693APU302    | Motion Mate APM300, 2-Axis   | 800         | -                   | -                |
| IC693APU305    | I/O Processor Module   | 360         | -                   | -                |
| IC693BEM320    | I/O Link Interface Module (slave)  | 205         | -                   | -                |
| IC693BEM321    | I/O Link Interface Master Module (w/o optical adapter)<br>(with Optical Adapter) | 415<br>615  | -<br>-              | -<br>-           |
| IC693BEM330    | FIP Remote I/O Scanner   | 609         | -                   | -                |
| IC693BEM331    | Genius Bus Controller  | 300         | -                   | -                |
| IC693BEM340    | FIP Bus Controller (maximum)<br>(typical)  | 1.2A<br>800 | -                   | -                |
| IC693CHS391    | 10-slot Modular CPU Baseplate  | 250         | -                   | -                |
| IC693CHS392    | 10-slot Expansion Baseplate  | 150         | -                   | -                |
| IC693CHS393    | 10-slot Remote Baseplate   | 460         | -                   | -                |
| IC693CHS397    | 5-slot Modular CPU Baseplate   | 270         | -                   | -                |
| IC693CHS398    | 5-slot Expansion Baseplate   | 170         | -                   | -                |
| IC693CHS399    | 5-slot Remote Baseplate  | 480         | -                   | -                |
| IC693CMM301    | Genius Communications Module   | 200         | -                   | -                |
| IC693CMM302    | Enhanced Genius Communications Module  | 300         | -                   | -                |
| IC693CMM311    | Communications Control Module  | 400         | -                   | -                |
| IC693CMM321    | Ethernet Interface Module  | 750         | -                   | -                |
| IC693CPU311    | Series 90-30 5-Slot Embedded CPU Baseplate                                       | 410         | -                   | -                |
| IC693CPU313    | Series 90-30 5-Slot Embedded CPU Baseplate                                       | 430         | -                   | -                |
| IC693CPU323    | Series 90-30 10-Slot Embedded CPU Baseplate                                      | 430         | -                   | -                |
| IC693CPU331    | CPU (Model 331)  | 350         | -                   | -                |
| IC693CPU340    | CPU (Model 340)  | 490         | -                   | -                |
| IC693CPU341    | CPU (Model 341)  | 490         | -                   | -                |
| IC693CPU350    | CPU (Model 350)  | 670 ‡       | -                   | -                |
| IC693CPU351    | CPU (Model 351)  | 890 ‡       | -                   | -                |
| IC693CPU352    | CPU (Model 352)  | 910 ‡       | -                   | -                |
| IC693CPU360    | CPU (Model 360)  | 670 ‡       | -                   | -                |
| IC693CPU363    | CPU (Model 363)  | 890 ‡       | -                   | -                |
| IC693CPU364    | CPU (Model 364)  | 1.51 A ‡    | -                   | -                |
| IC693CSE313    | State Logic CPU, 5-slot baseplate  | 430         | -                   | -                |
| IC693CSE323    | State Logic CPU, 10-slot baseplate   | 430         | -                   | -                |

| Catalog Number   | Description                                      | +5 VDC   | +24 VDC Relay Power | +24 VDC Isolated |
|------------------|--|----------|---------------------|------------------|
| IC693CSE340      | State Logic CPU Module                           | 490      | -                   | -                |
| IC693DSM302/314* | Motion Mate DSM302 or DSM314 Module              | 1.3A     | -                   | -                |
| IC693MAR590      | 120 VAC Input, relay Output, 8 In/8 Out          | 80       | 70                  | -                |
| IC693MDL230      | 120 VAC Isolated, 8 Point Input                  | 60       | -                   | -                |
| IC693MDL231      | 240 VAC Isolated, 8 Point Input                  | 60       | -                   | -                |
| IC693MDL240      | 120 VAC, 16 Point Input                          | 90       | -                   | -                |
| IC693MDL241      | 24 VAC/DCPos/Neglogic, 16 Point                  | 80       | -                   | 125              |
| IC693MDL310      | 120 VAC, 0.5A, 12 Point Output                   | 210      | -                   | -                |
| IC693MDL330      | 120/240VAC, 1A, 8 Point Output                   | 160      | -                   | -                |
| IC693MDL340      | 120 VAC, 0.5A, 16 Point Output                   | 315      | -                   | -                |
| IC693MDL390      | 120/240VAC Isolated, 2A, 5 Point Output          | 110      | -                   | -                |
| IC693MDL630      | 24 VDC Positive Logic, 8 Point Input             | 2.5      | -                   | 60               |
| IC693MDL632      | 125 VDC Pos/Neg Logic, 8 Point Input             | 40       | -                   | -                |
| IC693MDL633      | 24 VDC Negative Logic, 8 Point Input             | 5        | -                   | 60               |
| IC693MDL634      | 24 VDC Pos/Neg Logic, 8 Point Input              | 80       | -                   | 125              |
| IC693MDL640      | 24 VDC Positive Logic, 16 Point Input            | 5        | -                   | 120              |
| IC693MDL641      | 24 VDC Negative Logic, 16 Point Input            | 5        | -                   | 120              |
| IC693MDL643      | 24 VDC Positive Logic, FAST 16 Point Input       | 5        | -                   | 120              |
| IC693MDL644      | 24 VDC Negative Logic, FAST 16 Point Input       | 5        | -                   | 120              |
| IC693MDL645      | 24 VDC Pos/Neg Logic, 16 Point Input             | 80       | -                   | 125              |
| IC693MDL646      | 24 VDC Pos/Neg Logic, FAST, 16 Point Input       | 80       | -                   | 125              |
| IC693MDL652      | 24 VDC Pos/Neg Logic 32 Point Input              | 5        | -                   | -                |
| IC693MDL653      | 24 VDC Pos/Neg Logic, FAST, 32 Point Input       | 5        | -                   | -                |
| IC693MDL654      | 5/12 VDC (TTL) Pos/Neg Logic, 32 Point           | 195/440† | -                   | -                |
| IC693MDL655      | 24 VDC Pos/Neg, 32 Point Input                   | 195      | -                   | 224              |
| IC693MDL730      | 12/24VDC Positive Logic, 2A, 8 Point Output      | 55       | -                   | -                |
| IC693MDL731      | 12/24VDC Negative Logic, 2A, 8 Point Output      | 55       | -                   | -                |
| IC693MDL732      | 12/24VDC Positive Logic, 0.5A, 8 Point Output    | 50       | -                   | -                |
| IC693MDL733      | 12/24VDC Negative Logic, 0.5A, 8 Point Output    | 50       | -                   | -                |
| IC693MDL734      | 125 VDC Pos/Neg Logic, 6 Point Output            | 90       | -                   | -                |
| IC693MDL740      | 12/24VDC Positive Logic, 0.5A, 16 Point Output   | 110      | -                   | -                |
| IC693MDL741      | 12/24VDC Negative Logic, 0.5A, 16 Point Output   | 110      | -                   | -                |
| IC693MDL742      | 12/24VDC Pos. Logic ESCP, 1A, 16 Point Output    | 130      | -                   | -                |
| IC693MDL750      | 12/24VDC Negative Logic, 32 Point Output         | 21       | -                   | -                |
| IC693MDL751      | 12/24VDC Positive Logic, 32 Point Output         | 21       | -                   | -                |
| IC693MDL752      | 5/24 VDC (TTL) Negative Logic, 0.5A, 32 Point    | 260      | -                   | -                |
| IC693MDL753      | 12/24VDC Positive Logic, 0.5A, 32 Point Output   | 260      | -                   | -                |
| IC693MDL930      | Relay, N.O., 4A Isolated, 8 Point Output         | 6        | 70                  | -                |
| IC693MDL931      | Relay, N.C. and Form C, 8A Isolated, 8 Point Out | 6        | 110                 | -                |
| IC693MDL940      | Relay, N.O., 2A, 16 Point Output                 | 7        | 135                 | -                |
| IC693MDR390      | 24 VDC Input, Relay Output, 8 In/8 Out           | 80       | 70                  | -                |
| IC693PCM300      | Programmable Coprocessor Module, 65K             | 425      | -                   | -                |
| IC693PCM301      | Programmable Coprocessor Module, 85K             | 425      | -                   | -                |
| IC693PCM311      | Programmable Coprocessor Module, 380K            | 400      | -                   | -                |
| IC693PRG300      | Hand-Held Programmer                             | 170      | -                   | -                |
| IC693PTM100*     | Power Transducer Module                          | 400      | -                   | -                |
| IC693TCM302      | Temperature Control Module                       | 150      | -                   | -                |

† Refer to module specifications in GFK-0898, Series 90-30 I/O Module Specifications Manual for more details.

‡ Note that the model 350–364 CPUs **do not** support the A version (IC690ACC901A) of the Miniconverter.

\* Note that this is preliminary information. The IC693DSM314 and IC693PTM100 will not be available until late 1999.

## Power Supply Loading Calculation Examples

Following are examples of calculations for determining the total load placed on a Series 90-30 PLC power supply by the Series 90-30 PLC hardware. All current figures are expressed in milliamps. Note that although each output is rated at 15 or 20 watts (with the exception that the +5 VDC output for the High Capacity power supply is rated at 30 watts), the total combined output can be no more than 30 watts. The power required by external circuits connected to the 24 VDC OUTPUT terminals on the power supply terminal strip should be added to the calculation.

### Example 1: Series 90-30, Model 323 Embedded CPU (10-slot baseplate)

| Component                          | +5V  | +24V Isolated | +24V Relay |
|------------------------------------|------|---------------|------------|
| IC693CPU323 Embedded CPU Baseplate | 430  |               |            |
| IC693PRG300 Hand-Held Programmer   | 170  |               |            |
| IC693ALG390 Analog Output          | 32   | 120           |            |
| IC693ALG220 Analog Input           | 27   | 98            |            |
| IC693APU300 HS Counter             | 190  |               |            |
| 24 VDC Input (16 points)           | 5    | 120           |            |
| IC693MDL340 Input Module           | 5    | 120           |            |
| IC693MDL740 Output Module          | 110  |               |            |
| IC693MDL240 Input Module           | 90   |               |            |
| IC693MDL310 Output Module          | 210  |               |            |
| IC693MDL940 Relay Out. Mod.        | 7    |               | 135        |
| IC693MDL930 Relay Out. Mod.        | 6    |               | 70         |
| Totals (milliamps)                 | 1281 | 458           | 205        |
| (Watts)                            | 6.41 | 10.99         | 4.92       |
| <b>Total Watts = 22.32</b>         |      |               |            |

### Example 2: Series 90-30, Model 351 Modular CPU (10-slot baseplate)

| Component                         | +5V   | +24V Isolated | +24V Relay |
|-----------------------------------|-------|---------------|------------|
| IC693CHS391 Modular CPU Baseplate | 250   |               |            |
| IC693CPU351 CPU Module            | 890   |               |            |
| IC690ACC901 Miniconverter Kit     | 100   |               |            |
| IC693PCM301 PCM Module            | 425   |               |            |
| IC693ALG390 Analog Output         | 32    | 120           |            |
| IC693ALG220 Analog Input          | 27    | 98            |            |
| IC693APU300 HS Counter            | 190   |               |            |
| IC693MDL340 Input Module          | 5     | 120           |            |
| IC693MDL740 Output Module         | 110   |               |            |
| IC693MDL240 Input Module          | 90    |               |            |
| IC693MDL310 Output Module         | 210   |               |            |
| IC693MDL940 Relay Out. Mod.       | 7     |               | 135        |
| Totals (milliamps)                | 2336  | 338           | 135        |
| (Watts)                           | 11.68 | 8.11          | 3.24       |
| <b>Total Watts = 23.03</b>        |       |               |            |

## Scan (Sweep) Time Calculation

Scan or Sweep time is the time it takes the PLC CPU to perform all of its tasks one time. Scan time contribution is the amount of time added to the PLC scan by the software and hardware components of the system. For systems that may be time-sensitive, this factor should be made part of the design specification. To help avoid timing issues, the theoretical scan time should be calculated so that appropriate solutions can be designed into the system up-front.

### Major Design Factors Affecting Scan Time

- Size of ladder program
- Type of CPU. Some CPUs have faster clock speeds and architecture than others.
- Types of instructions used in ladder program
- Number of modules
- Types of modules. Some modules, such as several of the Option modules, have a much greater impact than others such as discrete I/O modules.
- Location of modules. This refers to the type of rack (CPU, Expansion, or Remote) that they are installed in.
- Connections to other devices such as an HMI, or to other systems via communications modules or ports.
- Cable types. Cable type can have a significant impact on scan time, especially when connecting Remote racks or communicating over long distances. Propagation time of data should be minimized to ensure proper system timing and margins. Suggested cable types for I/O Bus Expansion and communication cables are documented in the “Cables” chapter. **Any deviation in cable types from those recommended may result in erratic or improper system operation.**

### Where to Find Scan Time Information

For information on calculating scan time, please refer to the “Sweep Time Calculation” section of GFK-0467, *Series 90-30/20/Micro PLC CPU Instruction Set Reference Manual*.

## Calculating PLC Heat Dissipation

The amount of heat dissipated by a PLC mounted in an enclosure can be an important factor in determining the enclosure size needed for the system. This is because the enclosure must be able to adequately dissipate the heat generated by all of the components mounted inside so that no components overheat. PLC heat dissipation is also a factor in determining the need for enclosure cooling options such as fans and air conditioning. Enclosure manufacturers generally consider enclosure heat dissipation as a factor in their enclosure selection guidelines. Instructions for calculating Series 90-30 PLC heat dissipation can be found in Appendix H, “Series 90-30 Heat Dissipation.”

## System Layout Guidelines

Because of the differences from one system to another, it is not practical to try to discuss every possible layout. Instead, this section offers guidelines and an example to help you lay out your system.

### Benefits of a Good Layout – Safe, Reliable, and Accessible

The layout of your system has a lot to do with how reliably your system will operate, how easy it will be to install, how well it will look, and how easy and **safe** it will be to maintain:

- **Safety and Maintenance** – A good layout helps **minimize the chance of electrical shock to personnel working on the system**. It lets maintenance technicians easily access the unit to make measurements, load software, check indicator lights, remove and replace modules, etc. It also makes it easier to trace wiring and locate components while troubleshooting.
- **Reliability** – Proper layout promotes good heat dissipation and helps eliminate electrical noise from the system. Excess heat and noise are two major causes of electronic component failure.
- **Installation Efficiency**– A well designed layout allows sufficient room to mount and wire the unit. This saves time and frustration.
- **Appearance** – A neat and orderly layout gives others a favorable impression of your system. It lets others know that careful thought went into the design of the system.

### PLC Rack Location and Clearance Requirement

The following list provides PLC rack mounting location guidelines. For an example layout, see the figure “Series 90-30 Example Layout” later in this chapter.

- Locate PLC racks away from other components that generate a lot of heat, such as transformers, power supplies, or power resistors.
- Locate PLC racks away from components that generate electrical noise such as relays and contactors.
- Locate PLC racks away from high voltages components and wiring such as circuit breakers and fusible disconnects, transformers, motor wiring, etc. This not only reduces electrical noise, but makes it safer for personnel working on the PLC.
- Locate PLC racks at a convenient level that allows technicians reasonable access for maintaining the system.
- Route sensitive input wires away from electrically noisy wires such as discrete output and AC wiring. This can be facilitated by grouping I/O modules to keep Output modules separated from sensitive Input modules.
- The PLC racks each require a 4” clearance space on all four sides (6 inches on the right end if using I/O Bus Expansion Cables) to ensure adequate ventilation/cooling. See the “Baseplates” chapter for baseplate size and clearance requirement information.

## Location of Modules in the PLC Racks

There are several factors to consider when laying out your PLC racks.

- **Location restrictions** – Although most modules can be located in any type of baseplate, a few of the Option modules (PCM, ADC, CMM, SLP) will only work in a CPU baseplate. The next figure identifies where you can locate the modules in your system.
- **Power Supply capacity** – Since some modules draw considerably more power than others, it is possible to overload the power supply by placing many of the modules requiring higher power in one rack. Therefore, before finalizing your rack layout you should calculate the power supply loading to ensure that you will not overload the power supply. See the section “Calculating Power Supply Loading.”
- **Noise Reduction** – Group I/O modules to keep Output modules separated from sensitive Input modules. This will facilitate keeping noisy wiring separated from sensitive wiring, as recommended in a previous section.

## Allowable Module Locations

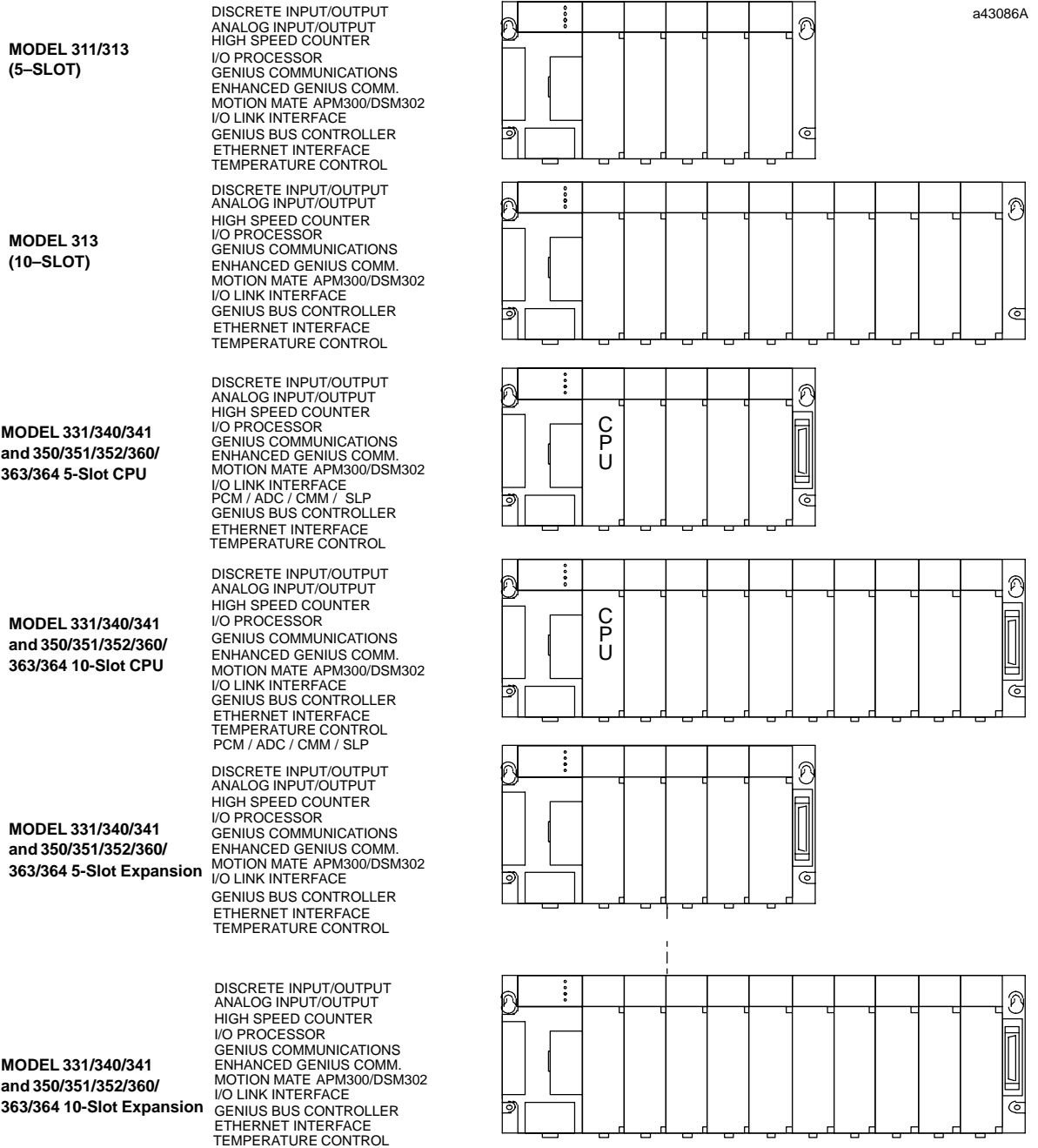

\* For location of FIP modules in baseplates, refer to the applicable FIP module user's manual.

Figure 12-2. Allowable Location of Modules

### Series 90-30 PLC Layout Example

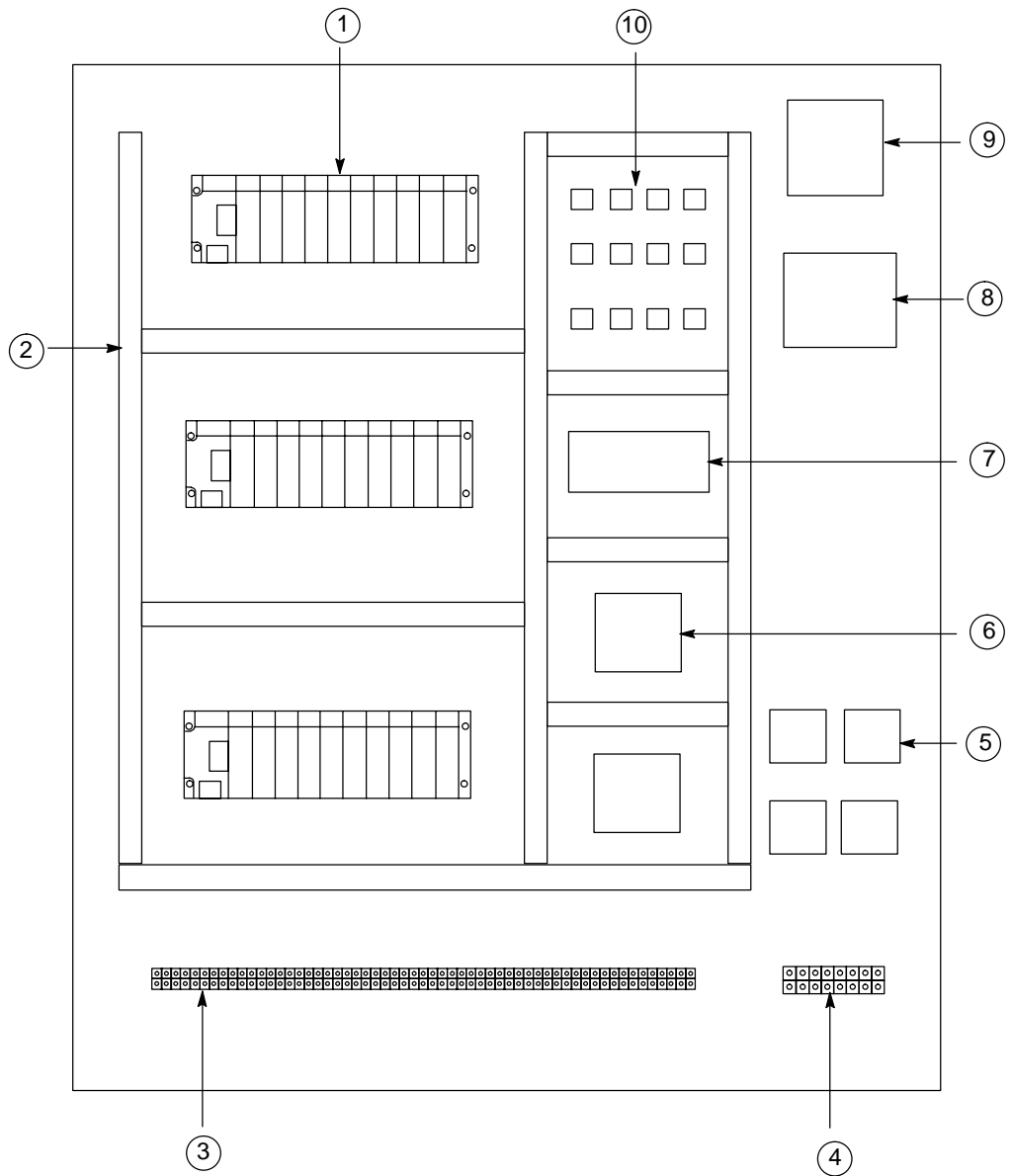

Figure 12-3. Series 90-30 Example Layout

- 1. Series 90-30 PLC, 10-slot rack
- 2. Wireway (Wire Duct)
- 3. Field device connection terminal block
- 4. Motor connection terminal block
- 5. Motor starters
- 6. Circuit board
- 7. Power supply
- 8. Control transformer
- 9. Fusible disconnect or circuit breaker
- 10. Control relays

## PLC Mounting Position

Power supply load rating depends on the mounting position of the baseplate and the ambient temperature.

### Recommended Upright Mounting Orientation

The load rating with the baseplate mounted upright on a panel is:

- 100% at 60°C (140°F)

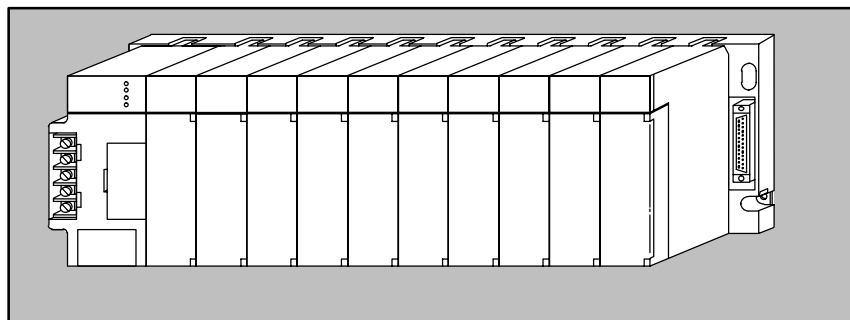

Figure 12-4. Recommended PLC Mounting Orientation

### Derated Horizontal Mounting Orientation

Power supply load ratings with the baseplate mounted horizontally are:

- temperature at 25°C (77°F) - full load
- temperature at 60°C (140°F) - 50% of full load

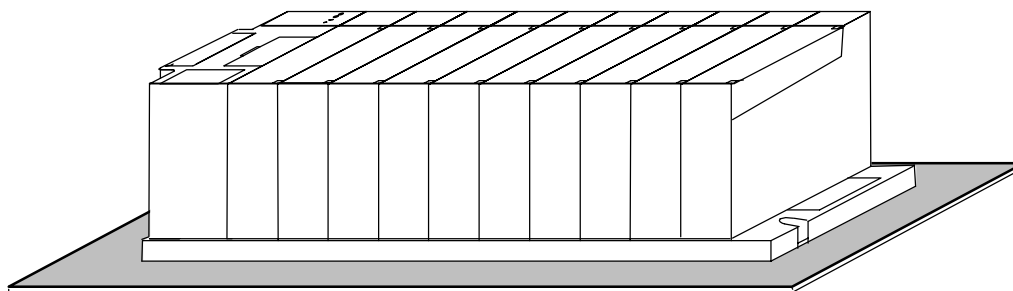

Figure 12-5. Derated PLC Mounting Orientation

### Troubleshooting Features of Series 90-30 Hardware

#### Indicator Lights (LEDs) and Terminal Board

The following figure shows how the indicator LEDs correspond to the circuit connection points on an I/O Module's terminal board. The terminal board terminals are numbered from the top, with the top terminal in the left row being number 1 and the top terminal in the right row being number 2. The numbers alternate between rows with even numbers on the right and odd numbers on the left, as shown in the circuit diagram on the back of the hinged cover.

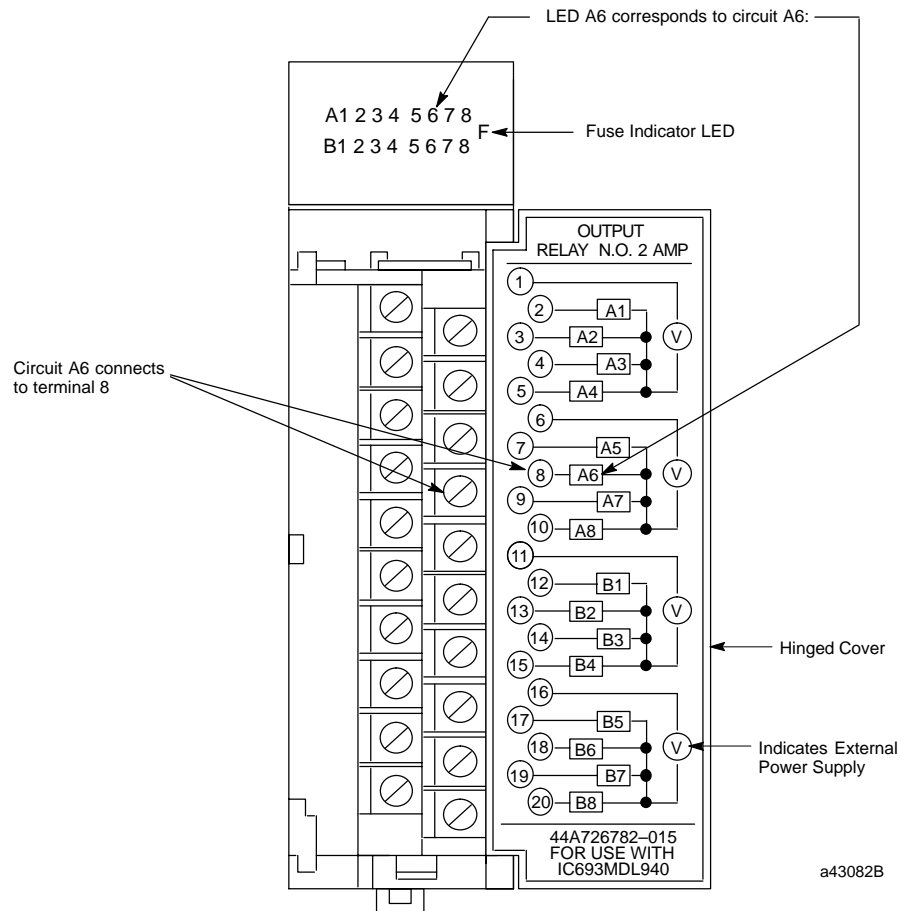

Figure 13-1. Relationship of Indicator Lights to Terminal Board Connections

## Module LED Indicators

### Input Module LED Indicators

When a discrete input device closes, the corresponding input LED should light to indicate that the signal reached the module. If the light does not turn ON, a voltage check can be made on the module's terminal board or block:

- If the correct voltage is present at the terminal, the corresponding input bit can be checked in the PLC with your programming software. If the software shows that the input bit is at logic 1, the module's LED circuit is defective.
- If the correct voltage level is not present at the terminal, a check can be made at the input field device to determine if the device or interconnecting wiring is defective.

If none of an input module's inputs are working, it may be that the external (field) input power supply is defective, is not powered up, or is not connected properly. (As indicated in the connections diagram in the previous figure, input and output devices are powered from an external power supply, not from inside the module). Input modules are not fused, so the Fuse Indicator LED in the previous picture does not apply to them.

### Output Module LED Indicators

When a discrete output address (%Q) is turned on in the ladder program, the corresponding output LED should light to indicate that the signal reached the module.

- If the light does not turn ON, the module may be defective or the LED light may be bad.
- If the light turns on but the output device doesn't operate, a voltage check can be made on the module's terminal board or block. If the correct voltage level is present there, a check could be made of the output device or wiring.

If none of an output module's outputs are working, it may be that the external (field) output power supply is defective, is not powered up, or is not connected properly. (As indicated in the connection diagram in the previous figure, input and output devices are powered from an external power supply, not from inside the module). If the output module is a type that has built-in fuses (some have electronic short circuit protection instead), the Fuse Indicator LED (labeled "F"), shown in the previous picture, will light if a fuse blows.

### Power Supply LED Indicators

The power supplies have four LED indicators. Their functions are explained in the "Power Supplies" chapter.

### CPU LED Indicators

There are several different LED arrangements on the various CPUs. These are explained in the "CPUs" chapter.

### Option Module LED Indicators

There are numerous LED arrangements on the various option modules. The "Option Modules" chapter has some information on this subject. It also directs you, for each module, to further information in the "Documentation" heading for each module. Also, Appendix I contains a catalog number to documentation cross-reference.

## Troubleshooting Features of Programming Software

Detailed information about the following items are found in GFK-0467, *Series 90-30/20/Micro PLC CPU Instruction Set Reference Manual*, and GFK-0466, *Series 90-30/20/Micro Programming Software User's Manual*.

### Ladder Screens

Contacts, connections, and coils displayed on the ladder screens that are ON (passing power or energized) are displayed in enhance brightness, allowing the tracing of signals through the program. Addresses that refer to physical input (%I and %AI) and output signals (%Q and %AQ) can be checked against module status lights, voltages, etc. to verify that the hardware is working properly.

### Configuration Screens

Normally, the following information is obtained from the system documentation. However, if they are not available, the configuration screens can be used to determine:

- If the software configuration matches the actual hardware. Sometimes, while troubleshooting, a module is installed in an incorrect slot by mistake. This will create a fault in one of the two fault tables. The correct configuration can be determined from the Configuration Screens.
- The memory addresses that a particular module is using.

### Fault Tables

There are two fault tables, the "PLC Fault Table," and the "I/O Fault Table." The fault tables can be viewed using the PLC programming software. These fault tables will not report such things as a defective limit switch, but will identify system faults such as:

- Loss of or Missing Modules, System Configuration Mismatch.
- CPU hardware failure, Low Battery
- PLC Software Failure, Program Checksum Failure, No User Program, PLC Store Failures.

### System Status References

These discrete references (%S, %SA, %SB, and %SC) can be viewed in the System Reference (Status) Table, or on-screen if used in the ladder program, for determining the status of various conditions and faults. For example, the %SC0009 bit turns on if a fault is logged in either fault table. Another example is that bit %SA0011 will turn on if the CPU memory backup battery is low. The *Series 90-30 PLC CPU Instruction Set Reference Manual*, GFK-0467, includes a "System Status Reference Table."

### Reference Tables

There are two types of reference tables, standard and mixed. These tables show groups of memory addresses and their status. For discrete addresses, the status of these will be shown as either logic 1 or logic 0. For analog and register addresses, values will be displayed. Standard tables display only one type of memory address, such as all of the %I bits. Mixed reference tables are created by the user, who selects what addresses to display in the tables. These mixed tables can contain discrete, analog, and register

references all in one table. This makes them useful for gathering numerous related addresses on one screen where they can all be viewed or monitored at the same time. This saves time compared with searching or scrolling through the ladder logic screens to find these addresses.

### Override feature

**This feature must be used with caution to ensure the safety of personnel and equipment. Normally, the machine should not be cycling, and all conditions should be such that the output device can be turned on without any harm being done.** This method can be used to check an output circuit from the ladder screen all the way to the device being controlled. For example, when overriding and toggling a %Q output to an ON state, the relay, solenoid, or other device being controlled should turn on or pick up. If it does not, the status light on the output module could be checked, then voltage checks could be made at the module terminal board, the system terminal strip, the machinery terminal strip, the solenoid or relay connections, etc. until the source of the fault is found.

### Sequential Event Recorder (SER), DOIO functional instruction

These can be set up to capture the status of specified discrete addresses upon receiving a trigger signal. They may be used to monitor and capture data about certain portions of the program, even when unattended. They can be useful for locating the cause of an intermittent problem. For example, a contact in a string of contacts that maintain power to a coil may, from time to time, momentarily open and interrupt normal operation. However, when maintenance personnel attempt to locate the problem, all of these contacts may test OK. By using the SER or DOIO instruction, the status of all of these contacts can be captured within milliseconds of the time the fault occurs, and the contact that opened will show a status of logic 0 at the moment of capture.

## Replacing Modules

Modules do not contain configuration switches. The slot in each baseplate (rack) is configured (using the configuration software) to hold a particular module type (catalog number). This configuration information is stored in CPU memory. Therefore, when replacing a module, you do not have to make any hardware settings on the module itself. You do, however, have to ensure that you install the correct module type in a particular slot.

Be aware that some “intelligent” modules, such as the CPU, PCM, APM, or DSM302, may contain application programs that will need to be reloaded after the module is replaced. For such modules, make sure that up-to-date copies of the application programs are maintained in case they have to be restored later.

For I/O modules with terminal boards, you do not have to rewire a new terminal board in order to replace the module. If the old terminal board is not defective, it can be removed from the old module and reinstalled on the new module without removing any of the wiring. Procedures for removing and installing modules and terminal boards are found in Chapter 2.

## Series 90-30 Product Repair

The Series 90-30 products are, for the most part, not considered to be field-repairable. The one major exception are the few modules that have replaceable fuses. The next section, “Module Fuse List,” identifies these modules and their applicable fuses. GE Fanuc offers a repair/product warranty service through your local distributor. Contact your distributor for details.

## Module Fuse List

### Warning

**Replace fuse only with the correct size and type. Using an incorrect fuse can result in harm to personnel, damage to equipment, or both.**

Table 13-1. Fuse List for Series 90-30 Modules

| Module Catalog Number       | Module Type                                       | Current Rating | Quantity on Module | GE Fanuc Fuse Part Number | Third Party Sources and Part Numbers                       |
|-----------------------------|---|----------------|--------------------|---------------------------|--|
| IC693CPU364                 | CPU Module with embedded Ethernet interface       | 1A             | 1                  | 44A725214-001             | Littlefuse - R454 001                                      |
| IC693DVM300                 | Digital Valve Driver                              | 1A<br>2A       | 1<br>4             | N/A<br>N/A                | Bussman - GDB-1A<br>Littlefuse - 239002                    |
| IC693MDL310                 | 120 VAC, 0.5A                                     | 3A             | 2                  | 44A724627-111(1)          | Bussman - GMC-3<br>Littlefuse - 239003                     |
| IC693MDL330                 | 120/240VAC, 1A                                    | 5A             | 2                  | 44A724627-114(1)          | Bussman - GDC-5<br>BussmanS506-5                           |
| IC693MDL340                 | 120 VAC, 0.5A                                     | 3A             | 2                  | 44A724627-111(1)          | Bussman - GMC-3<br>Littlefuse - 239003                     |
| IC693MDL390                 | 120/240VAC, 2A                                    | 3A             | 5                  | 44A724627-111(1)          | Bussman - GMC-3<br>Littlefuse - 239003                     |
| IC693MDL730                 | 12/24VDC Positive Logic, 2A                       | 5A             | 2                  | 259A9578P16(1)            | Bussman - AGC-5<br>Littlefuse - 312005                     |
| IC693MDL731                 | 12/24VDC Negative Logic, 2A                       | 5A             | 2                  | 259A9578P16(1)            | Bussman, AGC-5<br>Littlefuse - 312005                      |
| IC693PWR321 and IC693PWR330 | 120/240VAC or 125 VDC Input, 30 Watt Power Supply | 2A             | 1                  | 44A724627-109(2)          | Bussman - 215-002 (GDC-2 or GMC-2)<br>Littlefuse - 239-002 |
| IC693PWR322                 | 24/48VDC Input, 30 Watt Power Supply              | 5A             | 1                  | 44A724627-114(2)          | Bussman - MDL-5<br>Littlefuse - 313005                     |
| IC693PWR328                 | 48 VDC Input 30 Watt Power Supply                 | 5A             | 1                  | 44A724627-114(2)          | Bussman - MDL-5<br>Littlefuse - 313005                     |
| IC693PWR331                 | 24 VDC Input, 30 Watt Power Supply                | 5A             | 1                  | 44A724627-114(2)          | Bussman - MDL-5<br>Littlefuse - 313005                     |
| IC693TCM302                 | Temperature Control Module                        | 2A             | 1                  | N/A                       | Littlefuse - 273002  |

(1) Mounted in clip. Accessible by removing circuit board from module housing.

(2) Line fuse. Mounted in clip - accessible by removing module front.

## Spare/Replacement Parts

Two kits (IC693ACC319 and IC693ACC320) provide mechanical spare parts for Series 90-30 modules. One covers I/O CPU, PCM, and other modules; the other is for power supply modules. These kits provide parts such as module levers, front covers, cases, etc. The following table describes the contents of each kit.

**Table 13-2. Spare/Replacement Parts**

| <b>Spare Parts</b>   | <b>Contents</b>  |
|--|--|
| <b>IC693ACC319:</b><br>Spare parts kit for I/O, CPU, and PCM modules | (qty. 10) I/QCPU, PCM case lever<br>(qty. 10) Spring pins cap<br>(qty. 2) PCM module front cover<br>(qty. 2) PCM lens cap<br>(qty. 2) CPU module case  |
| <b>IC693ACC320:</b><br>Spare parts kit for power supplies            | (qty. 2) Power supply lever<br>(qty. 2) Spring pin for power supply lever<br>(qty. 2) Spring for power supply lever<br>(qty. 2) Power supply lens cap<br>(qty. 2) Power supply terminal cover  |
| <b>IC693ACC301 (see Note)</b><br>Memory Backup Battery               | (qty. 2) Memory backup battery for CPU and PCM modules   |
| <b>Fuses</b>   | See "Fuse List For Series 90-30 Modules" table in this chapter.  |
| <b>Modules</b>   | You may wish to maintain spare PLC modules. Many systems have more than one of a particular catalog number, such as power supplies (each rack has one) and I/O modules. In these cases, one of each type would serve as backups for several modules. |
| <b>IC693ACC311</b><br>Removable Module Terminal Board                | (qty. 6) Removable terminal boards used on many I/O modules and some Option modules.   |
| <b>44A736756-G01</b><br>CPU (CPU350 - 364) Key Kit                   | Kit contains 3 sets (6 keys). Same key fits all applicable CPUs.   |

Note: The IC693ACC301 batteries have a shelf life of 5 years (see Chapter 6 for instructions on how to read battery date codes). Periodically outdated batteries should be removed from stock and disposed of according to the battery manufacturer's recommendations.

## Preventive Maintenance Suggestions

| Series 90-30 PLC Preventive Maintenance |                                     |   |
|---|-------------------------------------|---|
| Item No.                                | Description                         | Recommendation  |
| 1                                       | Safety ground and electrical system | Check frequently to ensure that safety ground connections are secure and that electrical cables and conduits are secure and in good condition.  |
| 2                                       | CPU Memory backup battery           | Replace annually or as appropriate for your application.* <b>Check Chapter 5 for instructions on how to avoid loss of memory contents when replacing battery.</b>   |
| 3                                       | Option Module backup battery        | Replace annually. <b>Check user's manual for additional instructions. Check Chapter 5 for instructions on how to avoid loss of memory contents when replacing battery.</b>  |
| 4                                       | Ventilation                         | If using ventilation fan in enclosure, check for proper operation. <b>Keep fingers and tools away from moving fans.</b> Clean or replace ventilation air filter, if using one, at least monthly.  |
| 5                                       | Mechanical tightness                | <b>With power OFF</b> , check that connectors and modules are seated securely in their sockets and that wire connections are secure. For low vibration installations, perform annually. For high vibration installations, check at least quarterly.   |
| 6                                       | Enclosure                           | Check annually. <b>With power OFF</b> , remove manuals, prints, or other loose material that could cause shorts or ventilation blockage, or that are flammable, from inside of enclosure. Gently vacuum dust and dirt that has collected on components. Use vacuum cleaner, not compressed air, for this task.  |
| 7                                       | Program backup                      | Do this initially after creating any application programs, such as the ladder logic program, motion programs, etc. Then, any time a change is made to a program, make at least one (several is better) new backup copy. Keep old copies (clearly marked) for a reasonable period of time in case you need to go back to the old design.<br><br>Document each backup copy as to what equipment it is for, date it was created or modified, version number (if any), and author's name.<br><br>Keep master backup copies in a safe place. Make working copies available to those responsible for maintaining the equipment. |

\*See "Factors Affecting Battery Life" in Chapter 5.

## Getting Additional Help and Information

There are several ways to get additional help and information:

### GE Fanuc Web Site

There is a large amount of information on the Technical Support section of the GE Fanuc Web site. Sections such as Technical Documentation, Application Notes, Revision Histories, Frequently Asked Questions, and Field Service Bulletins may have the exact information you need. You can access this site at:

<http://www.gefanuc.com/support/>

### Fax Link System

This system lets you choose technical help documents to be sent to you on your Fax machine. To use this system follow these steps:

- Call Fax Link at (804) 978-5824 on a touch tone type phone (rotary dial phones will not work for this application).
- Follow the instructions to have a master list (called "Document 1") of Fax Link documents Faxed to you. A master Fax Link list is also available on the GE Fanuc Web site in the Technical Support section (see the "GE Fanuc Web Site" section above).
- Select desired document(s) from the master list, then call Fax Link and specify the document number(s) you want to be Faxed to you. Up to three documents can be ordered per call.

### GE Fanuc Telephone Numbers

If you need to speak with a GE Fanuc technical help person, use the applicable telephone number from the following list.

| Location   | Telephone Number                                     |
|--|--|
| North America, Canada, Mexico (Technical Support Hotline)    | Toll Free: 800 GE Fanuc<br>Direct Dial: 804 978-6036 |
| Latin America (for Mexico, see above)                        | Direct Dial: 804 978-6036                            |
| France, Germany, Luxembourg, Switzerland, and United Kingdom | Toll Free: 00800 433 268 23                          |
| Italy  | Toll Free: 16 77 80 596                              |
| Other European Countries                                     | +352 727 979 309                                     |
| Asia/Pacific - Singapore                                     | 65 566 4918  |
| India  | 91 80 552 0107                                       |

## Glossary of Terms for the Series 90-30 PLC

|   |   |
|---|---|
| <b>Address</b>  | Consists of a letter followed by a number, which together refer to a specific memory location. For example, %I00005 refers to the fifth location in input (%I) memory.                                      |
| <b>Analog</b>   | An electrical signal activated by physical variables representing force, pressure, temperature, flow, etc. It's a signal represented by a value rather than a simple on or off state.                       |
| <b>Application Program</b>  | A program written by the user to control a particular machine or process.   |
| <b>ASCII (American Standard Code for Information Interchange)</b> | An 8-bit (7 bits plus 1 parity bit) code used for data.   |
| <b>Backplane</b>  | A circuit board consisting of a group of connectors and associated circuitry. The connectors accept plug-in modules.  |
| <b>Baseplate</b>  | A frame that contains and protects the backplane circuit board. In the Series 90-30 PLC Models 311, 313, and 323 the baseplate also contains the CPU.   |
| <b>Battery Connector</b>  | A connector wired to a lithium battery which connects the battery to the CMOS RAM memory devices. The battery connector is plugged into a receptacle accessed through a door on the power supply faceplate. |
| <b>Baud</b>   | A unit of data transmission. Baud rate is approximately equal to the number of bits per second transmitted.   |

**Bit (Binary Digit)**

The smallest unit of memory. It can be used to store only one piece of information that has two states (for example, One/Zero, On/Off, Good/Bad, Yes/No). Data that requires more than two states (e.g., numerical values 000 to 999) requires multiple bits (see Word).

**Bus**

An electrical path, usually shared by two or more devices, for transmitting and receiving data or power.

**Byte**

A group of binary digits operated on as a single unit. In the Series 90-30 PLC, a byte consists of eight contiguous bits.

**Circuit Wiring Diagram**

Field wiring information that provides a guide to users for connecting field devices to input and output modules. Each I/O module has a circuit wiring diagram printed on the inside surface of an insert in the module's hinged door.

**Configuration Software**

That portion of a programming software package that provides the tools for configuring the hardware scheme as well as certain system parameters.

**CPU (Central Processing Unit)**

The central device or controller that interprets user instructions, makes decisions, and executes the functions based on a stored application program.

**CPU Baseplate**

The baseplate in a Series 90-30 PLC system in which the CPU is installed. This rack must always be included in a system and is always rack 0. There can only be one CPU per PLC.

**Data Memory**

User references within the CPU which are accessible by the application program for storage of discrete or register data.

**Discrete**

Refers to devices that are either on or off.

**Expansion Baseplate (Local)**

A 5 or 10-slot baseplate added to a Series 90-30 PLC when the application calls for more modules than the CPU baseplate can contain. CPU models 331 – 341 support up to four expansion baseplates. CPU models 350 – 364 support up to seven expansion baseplates. The last expansion baseplate in the system can be no more than 50 feet from the CPU baseplate.

**Expansion Cable (I/O Bus)**

A cable that propagates the parallel I/O bus signals between expansion baseplates. The total length of all expansion cables, from the main baseplate to the last expansion baseplate in the system, can be no more than 50 feet (15 meters).

**Field Devices**

Input or output devices external to the PLC such as pushbutton or limit switches, relays, pilot lights, solenoids.

---

|  |  |
|--|--|
| <b>Firmware</b>                                  | A series of operating system instructions contained in PROM (Programmable Read Only Memory) which are used for internal processing functions. These instructions provide the structure for application program operations.         |
| <b>Flash Memory</b>                              | A non-volatile EEPROM type memory device.  |
| <b>Genius I/O</b>                                | An intelligent I/O system consisting of I/O blocks, bus controllers, and other devices.  |
| <b>Grounding Terminal</b>                        | A terminal on each power supply which must be connected to earth ground (through the AC power source) to ensure that the power supply is properly and safely grounded.   |
| <b>Hardware</b>                                  | All of the physical (mechanical, electrical, and electronic) devices that comprise the Series 90-30 PLC and its applications.  |
| <b>Hinged Door</b>                               | A plastic door on the front of a module which, when open, allows access to certain module hardware features.   |
| <b>Input Module</b>                              | An I/O module that converts signals from user devices to logic levels that can be used by the CPU.   |
| <b>Input Scan Time</b>                           | The time required for the CPU to scan all input devices for new input values.  |
| <b>I/O (Input/Output)</b>                        | That portion of the PLC to which field devices are connected and which isolates the CPU from electrical noise.   |
| <b>I/O Electrical Isolation</b>                  | A method of separating field wiring from logic level circuitry. Typically, this is accomplished through the use of solid-state optical isolation devices.  |
| <b>I/O Fault Table</b>                           | A fault table listing I/O faults. These faults are identified by time, date, and location.   |
| <b>I/O Module</b>                                | A plug-in module containing a printed circuit assembly that interfaces between user devices and the Series 90-30 PLC.  |
| <b>K (Kilo)</b>                                  | An abbreviation for kilo or exactly 1024 in the language of computers.   |
| <b>LED (Light Emitting Diode) Status Display</b> | A display consisting of LEDs located at the top of many Series 90-30 modules. The LEDs indicate such things as On or Off status of discrete points, OK status of Option modules, or the transfer of data over communication ports. |
| <b>Main Baseplate</b>                            | Same as CPU Baseplate.   |

|                                |  |
|--------------------------------|--|
| <b>Memory Card</b>             | A memory cartridge containing EEPROM memory which is inserted into a slot in the Hand-Held Programmer. This memory cartridge, provides the Hand-Held Programmer with a means for off-line storage and retrieval of the application program and system configuration data.  |
| <b>Microsecond</b>             | One millionth of a second. $1 \times 10^{-6}$ or 0.000001 second. Microsecond may be abbreviated as micros.  |
| <b>Millisecond</b>             | One thousandth of a second. $1 \times 10^{-3}$ or 0.001 second. Millisecond may be abbreviated as ms.  |
| <b>Mnemonic</b>                | An abbreviation given to an instruction. The mnemonic is often an acronym, formed by combining initial letters or parts of words.  |
| <b>Model 30 I/O</b>            | The Series 90-30 I/O subsystem consisting of discrete, analog, and intelligent input and output modules.   |
| <b>Module</b>                  | A replaceable electronic subassembly usually plugged into connectors on a backplane and secured in place, but easily removed in case of a failure or system redesign. In the Series 90-30 PLC, a combination of a printed circuit board and its associated faceplate (and removable terminal connector on I/O modules) which, when combined, form a complete assembly. |
| <b>Noise</b>                   | Undesirable electrical disturbances to normal signals, generally of high frequency content.  |
| <b>Non-Volatile Memory</b>     | A memory (for example, EPROM) capable of retaining its stored information under no-power conditions (power removed or turned off).   |
| <b>Off-Line Mode</b>           | Off-Line mode is used for program development. The programmer does not communicate with the PLC in Off-Line mode; the physical communications link may be intact, but the programmer is specifically not performing communications with the PLC. Power flow display and reference values are not updated.  |
| <b>On-Line Mode</b>            | On-Line mode provides full CPU communications, allowing data to be both read and written.  |
| <b>Output</b>                  | Data transferred from the CPU, through an Output interface module to an external device or process.  |
| <b>Output Devices</b>          | Physical devices such as motor starters, solenoids, etc., that are switched by the PLC. See "Field Devices."   |
| <b>Output Module</b>           | An I/O module that converts logic level signals within the CPU to usable output signals for controlling a machine or process.  |
| <b>Parallel Communications</b> | A method of data transfer, whereby data is transferred on several wires simultaneously.  |

**Peripheral Equipment**

External devices that can communicate with a PLC (for example, programmers and printers).

**PLC (Programmable Logic Controller)**

A solid-state industrial control device which receives signals from user-supplied control devices, such as switches and sensors, implements them in a precise pattern determined by ladder diagram based application programs stored in user memory, and provides outputs for control of processes or user-supplied devices such as relays or motor starters. It is usually programmed in relay ladder logic and is designed to operate in an industrial environment.

**PLC Fault Table**

A fault table listing PLC faults. These faults are identified by time, date, and location.

**Programmer**

Usually consists of a personal computer running the PLC programming software.

**Programmer Port**

The serial port on the power supply module, accessible through a 15-pin connector, to which the programmer must be connected in order to communicate with the PLC. Both the PC-based programmer and the Hand-Held Programmer connect to this port.

**Programming Software**

That portion of the programming software package that is used to create ladder logic programs.

**PROM (Programmable Read Only Memory)**

A retentive digital device programmed at the factory and not easily changed by the user. PROM usually contains operating system instructions for internal system use.

**Rack**

A Series 90-30 baseplate when it has modules installed in it.

**Rack Number**

A unique number, assigned to each rack for identification purposes. The numbers range from 0 to 4, assigned for a system with a Model 331 – 341 CPU, or from 0 to 7 for a Model 351 – 364 CPU. The CPU (main) rack is always rack 0.

**Rack Number DIP Switch**

A three-position DIP switch, located on an Expansion or Remote baseplate directly behind the power supply, used to assign a rack number.

**RAM (Random Access Memory)**

A solid-state memory that allows data to be stored and accessed at random locations. This memory stores program files and related data while power is applied to the system. This type of memory, however, is volatile. Because data stored in RAM is lost under no-power conditions, a backup battery is usually used to retain the con-

tents under those conditions. The backup battery used in the Series 90-30 PLC is a long-life lithium battery mounted on the power supply, PCM, and ADC modules.

|                                 |  |
|---------------------------------|--|
| <b>Reference Type</b>           | A specific group of memory types in the Series 90-30 PLC (for example, %I references discrete inputs and %Q references discrete outputs). The % symbol is used to distinguish machine references (memory addresses) from nicknames.  |
| <b>Register</b>                 | A group of 16 consecutive bits in register memory, referenced as a %R address. Each register is numbered, beginning at %R00001. Register memory is used for temporary storage of numerical values and for bit manipulation.  |
| <b>Release Lever</b>            | A molded lever on the bottom of each Model 30 I/O module, which when depressed upwards, releases the module in its slot to allow removal of the module.  |
| <b>Remote Baseplate</b>         | A 5 or 10-slot baseplate added to a system when the application calls for the presence of a baseplate more than 50 feet from the CPU baseplate. CPU models 331, 340, or 341 support up to four remote baseplates (or a combination of remote and expansion baseplates as long as the distance and cable requirements are followed) with the last remote baseplate no more than 700 feet (213 meters) from the CPU baseplate. CPU models 350 – 364 support up to seven expansion baseplates.  |
| <b>Removable Terminal Block</b> | The removable assembly which attaches to the front of an I/O module, and contains the screw terminals to which field wiring is connected.  |
| <b>Restart Pushbutton</b>       | A pushbutton on the front of the module used to reinitialize the PCM, ADC, or GDC module, or to initiate a hard or soft reset of the module. The TCP/IP Ethernet Interface module also has a restart pushbutton which has multiple functions.  |
| <b>RUN Mode</b>                 | A condition or state of the Series 90-30 PLC, where the CPU executes the application program. RUN mode executes in the RUN/OUTPUTS ENABLED mode only. In RUN/OUTPUTS ENABLED, all portions of the program sweep are executed.  |
| <b>Scan</b>                     | Also called “Sweep.” The routine that the CPU performs repeatedly in performing its sequence of tasks. The basic scan runs in this sequence: housekeeping tasks, input tasks, ladder logic solving, output tasks, programmer communications, and option module communications. Once the CPU reaches the end of a scan, it begins another one and continues this sequence until stopped by a fault or by human intervention. Each scan takes a measurable amount of time (milliseconds), which may have an impact on time-critical tasks. |

**Serial Communications**

A method of data transfer, whereby the bits are handled sequentially rather than simultaneously, as in parallel data transmission.

**Serial Port**

An RS-485/422 port on the PLC, accessible through a 15-pin connector, to which the programmer must be connected in order to communicate with the PLC. Both the Logicmaster 90 programmer and the Hand-Held Programmer connect to this port. The PLC can communicate with other serial devices through this port. A converter is needed when communicating with an RS-232 device through this port.

**STOP Mode**

A condition or state of the Series 90-30 PLC, where the CPU no longer executes the application program. STOP mode can be STOP/NO IOSCAN or STOP/IOSCAN. In STOP/NO IOSCAN mode, the PLC only communicates with the programmer and other devices (GBC, PCM, etc.), recovers faulted boards, reconfigures boards and executes background tasks. All other portions of the sweep are skipped. In STOP/IOSCAN mode, the PLC CPU can monitor I/O. This feature provides a way to monitor and debug I/O without executing the application program.

**Storage**

Used synonymously with memory.

**Sweep**

See "Scan."

**Termination Resistor Pack**

A resistor pack used to properly terminate the I/O Expansion Bus signals. It is physically installed inside of a terminator plug (IC693ACC307), or termination resistors are connected internally in the 50 foot I/O bus expansion cable (IC693CBL302).

**Terminator Plug**

A connector containing a resistor pack which must be installed at the end of the I/O Expansion Bus chain to properly terminate I/O bus signals. This plug must be installed on the unused connector on the last I/O expansion cable in the I/O Expansion Bus chain. Unexpected system operation may occur if the bus is not properly terminated.

**User Memory**

The portion of system memory in which the application program and data is stored. This memory is battery-backed CMOS RAM.

**User Reference Type**

A reference assigned to data which indicates the memory in which it is stored in the PLC. References can be either bit-oriented (discrete) or word-oriented (register).

**Volatile Memory**

A type of memory that will lose the information stored in it if power is removed from the memory devices. It requires a backup battery for retention of contents of memory. In the Series 90-30 PLC, a lithium battery is used for this purpose.

- Watchdog Timer** A timer in the CPU used to ensure that certain hardware conditions are met within a predetermined time. If the CPU scan runs longer than the time setting of the Watchdog Timer, a fatal fault will occur which will stop PLC operation.
- Word** A measurement of memory length. In the Series 90-30 PLC, a word is 16-bits in length.
- Wye** A circuit or connection point with three branches, sometimes drawn schematically in the shape of a letter Y. A cable with a double connector on one end and a single connector on the other.

# Appendix B

## Acronyms and Abbreviations

[efesotomasyon.com](http://efesotomasyon.com)

---

---

|            |  |
|------------|--|
| AAUI       | Apple Attachment Unit Interface  |
| ADC        | Alphanumeric Display Coprocessor module  |
| ADS        | Alphanumeric Display System  |
| AIA/NAS    | Aerospace Industries of America  |
| ANSI       | American National Standards Institute  |
| API        | American Petroleum Institute   |
| APM        | Axis Positioning Module  |
| AREA       | American Railway Engineering Association   |
| ASCII      | American National Standard Code for Information Interchange  |
| ASCE       | American Society of Civil Engineers  |
| ASME       | American Society of Mechanical Engineers   |
| BCD/BCDD   | Binary Coded Decimal and Binary Coded Decimal Digit  |
| CCM        | Communications Control Module (protocol). Originally developed as a communications protocol for the Communications Control Module in the Series Six PLC. This protocol is also used on the Series 90-30. |
| CMM        | Abbreviation for the Series 90-30 Communications Control Module, based on the module's catalog number (IC693CMM311).   |
| CMOS       | Complementary Metal Oxide Semiconductor  |
| CPU        | Central Processing Unit  |
| COM        | Serial COMMunications Port   |
| C-UL-US    | Dual Canadian and US listing mark of Underwriter's Laboratories.   |
| DER        | Digital Event Recorder   |
| DIN        | Deutches Institute for Normung   |
| DIP        | Dual-In-Line Package (DIP switch)  |
| DSM        | Digital Servo Module   |
| DVD/DVDM   | Digital Valve Driver and Digital Valve Driver Module   |
| EGD        | Ethernet Global Data   |
| EIA        | Electronic Industries Association  |
| EPROM      | Erasable Programmable Read Only Memory   |
| EEPROM     | Electrically Erasable Programmable Read Only Memory  |
| EU         | European Union   |
| FIP        | Factory Instrumentation Protocol   |
| GBC        | Genius Bus Controller  |
| GCM        | Genius Communications Module   |
| GCM+       | Enhanced Genius Communications Module  |
| H (or Hex) | Hexadecimal  |
| HHP        | Hand-Held Programmer   |
| HSC        | High Speed Counter   |

---

|        |  |
|--------|--|
| I/O    | Input/Output   |
| ICEA   | Insulated Cable Engineers Association                                    |
| IEC    | International Electrotechnical Commission                                |
| IEEE   | Institute of Electrical and Electronic Engineers                         |
| IOP    | Input/OutputProcessor  |
| ISO    | International Organization for Standardization                           |
| IOC    | Input/OutputController   |
| ISCP   | Instruction Sequencer Coprocessor  |
| JIS    | Japanese Industrial Standards  |
| K      | 1024 (Abbreviation for Kilobyte)   |
| Kbyte  | Kilobyte (1024 bytes)  |
| LAN    | Local Area Network   |
| LED    | Light Emitting Diode   |
| LCD    | Liquid Crystal Display   |
| Mbyte  | Megabyte (1,048,576 bytes)   |
| NEC    | National Electrical Code (by National Fire Protection Association)       |
| NEMA   | National Electrical Manufacturers Association                            |
| NFPA   | National Fire Protection Association or National Fluid Power Association |
| NIST   | National Institute of Standards and Technology                           |
| OEM    | Original Equipment Manufacturer  |
| OSHA   | Occupational Safety and Health Administration                            |
| PC     | Personal Computer  |
| PCIF   | Personal Computer Interface card   |
| PCM    | Programmable Coprocessor Module  |
| PE     | Protective Earth (ground)  |
| PLC    | Programmable Logic Controller  |
| PROM   | Programmable Read Only Memory  |
| PS     | Power Supply   |
| PTM    | Power Transducer   |
| PTMPM  | Power Transducer Processor Module  |
| PTMIM  | Power Transducer Interface Module  |
| RAM    | Random Access Memory   |
| RTD    | Resistive Temperature Detector   |
| RTU    | Remote Terminal Unit   |
| SER    | Sequential Event Recorder  |
| SL     | Statement List Language (also refers to SL Series Servo products)        |
| SLP    | State Logic Processor  |
| SNP    | Series 90 Protocol   |
| TBQC   | Terminal Block Quick Connect   |
| TCM    | Temperature Control Module   |
| TCP/IP | Transmission Control Protocol/Internet Protocol                          |
| TOD    | Time-Of-Day  |
| TP     | Twisted Pair   |
| UDP    | User Datagram Protocol   |
| UL     | Underwriter's Laboratories   |
| UTP    | Unshielded Twisted Pair  |
| WSI    | Work Station Interface   |

# Appendix C

## Serial Port and Cables

[efesotomasyon.com](http://efesotomasyon.com)

---

---

This appendix describes the serial port, converter, and cables used to connect Series 90 PLCs for Series 90 Protocol (SNP). This information is included for reference and for those users who have applications that require cable lengths different than the factory-supplied cables.

### What this Appendix Contains

Information in this section includes:

- Communications Interface
- Cable and Connector Specifications
- Serial Port Configuration
- RS-232/RS-485 Converter (Catalog No. IC690ACC900)
- Serial Cable Diagrams
  - Point-to-Point Connection
  - Multidrop Connection

### RS-422 Interface

The Series 90 PLC family of products are compatible with EIA RS-422 specifications. RS-422 drivers and receivers are utilized to accomplish communications between several system components using multiple driver/receiver combinations on a single cable with five twisted pairs. The cable length between master and any slave cannot exceed 4,000 (1,219 meters) feet.

A multi-drop system of eight drivers and receivers can be configured. The maximum common mode voltage between each additional drop is the RS-422 standard of +7 Volts to -7 Volts. The driver output must be capable of  $\pm 2$  V minimum into 100 ohms. The driver output impedance must be at least 120 K ohms in the high impedance state. The receiver input resistance is 12 K ohms or greater. Receiver sensitivity is  $\pm 200$  millivolt.

#### Caution

**Care must be taken that common mode voltage specifications are met. Common mode conditions that exceed those specified will result in errors in transmission and/or damage to Series 90 PLC components. When the common mode voltage specification is exceeded, a port isolator such as the GE Fanuc IC690ACC903 must be used. See Appendix G for details on this port isolator.**

## Cable and Connector Specifications

The cable assembly presents one of the most common causes of communication failure. For best performance construct the cable assemblies according to the recommended connector parts and specifications.

Table C-1. Connector/Cable Specifications

| Item               | Description   |
|--------------------|---|
| Mating Connectors: | <p><b>Series 90 PLC:</b> Serial (RS-422) port with metric hardware<br/> Connector: 15-pin male, D-Subminiature Type, Cannon DA15S (solder pot)<br/> Hood: AMP 207470-1 connector shell<br/> Hardware Kit: AMP 207871-1 Kit includes 2 metric screws and 2 screw clips</p>   |
|                    | <p><b>Workmaster II:</b> Serial (RS-232) port with standard RS-232 connector<br/> Connector: 25-pin female, D-Subminiature Type, Cannon DB25S (solder pot) with DB110963-3 hood or equivalent (standard RS-232 connector)</p>   |
|                    | <p><b>Workmaster:</b> Serial (RS-232) port with standard RS-232 connector<br/> Connector: 9-pin female, D-Subminiature Type, Cannon DE9S (solder pot) with DE110963-1 hood or equivalent (standard RS-232 connector)</p>  |
|                    | <p><b>IBM-AT/XT:</b> Serial (RS-232) port with standard RS-232 connector<br/> Connector: 9-pin female, D-Subminiature Type, Cannon DE9S (solder pot) with DE110963-31 hood or equivalent (standard RS-232 connector)</p>  |
|                    | <p><b>RS-232/RS-485 Converter:</b> one 15-pin male, and one 25-pin male connector<br/><br/> 15-pin male connector requires metric hardware (same connector, hood, and hardware as for Series 90 PLC listed above)<br/><br/> 25-pin male D-Subminiature Type, Cannon DA25S (solder pot) with DB110963-3 hood or equivalent (standard RS-232 connector)</p>   |
| Cable:             | <p>Computer grade, 24 AWG (.22 mm<sup>2</sup>), minimum with overall shield<br/> Catalog Numbers: Belden 9505, Belden 9306, Belden 9832<br/> These cables provide acceptable operation for data rates up to 19.2 Kbps as follows:<br/> RS-232: 50 feet (15 meters) maximum cable length<br/> RS-422/RS-422: 4000 feet (1200 meters) maximum length. Must not exceed the maximum RS-422 Common Mode specification of +7V to -7V. Isolation at the remote end may be used to reduce or eliminate Common Mode voltages.<br/><br/> For distances under 50 feet (15 meters), almost any twisted pair or shielded twisted pair cable will work, as long as the wire pairs are connected correctly.<br/><br/> When using RS-422/RS-422, the twisted pairs should be matched so that both transmit signals make up one twisted pair and both receive signals make up the other twisted pair. If this is ignored, cross-talk resulting from the mismatching will affect the performance of the communications system.<br/><br/> When routing communication cables outdoors, transient suppression devices can be used to reduce the possibility of damage due to lightning or static discharge.<br/><br/> <i>Care should be exercised that all connected devices are grounded to a common point. Failure to do so could result in damage to the equipment.</i></p> |

## Series 90 PLC Serial Port

The Series 90 PLC serial port is compatible with RS-422. An RS-232 to RS-422 converter is required to interface to systems that provide RS-232 compatible interfaces. The Series 90 PLC, RS-422 serial port provides the physical connection for SNP communication. This port is a 15-pin D-type female connector located as follows:

- Series 90-70 PLC and Series 90-20 – CPU Module
- Series 90-30 PLC – Power Supply

Figure C-1 shows the serial port orientation and connector layout for the Series 90 PLC types (note that the orientation of the connector on the Series 90-20 CPU is rotated 90 degrees from the Series 90-30 connector with pin 1 to the upper right). Table C-2 shows the pin numbering and signal assignment applicable to both PLCs.

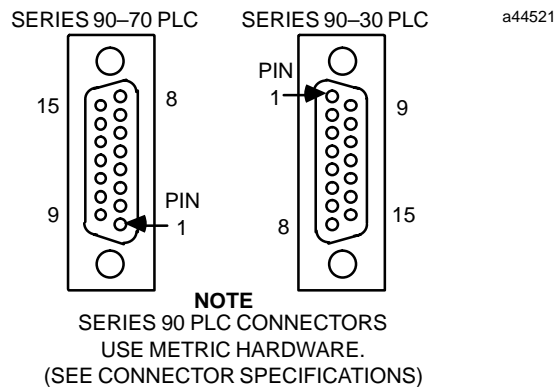

**Figure C-1. Series 90 PLC, RS-422 Serial Port Connector Configuration**

**Table C-2. Series 90 PLC, RS-422 Serial Port Pin-out**

| Pin Number | Signal Name   | Description                                 |
|------------|---------------|---|
| 1          | Shield        |   |
| 2          |               | No Connection                               |
| 3          |               | No Connection                               |
| 4          | ATCH *        | Hand-Held Programmer attach signal          |
| 5          | +5V *         | +5V Power for: HHP and RS-232/485 Converter |
| 6          | RTS (A)       | Request To Send                             |
| 7          | Signal Ground | Signal Ground, OV                           |
| 8          | CTS (B')      | Clear To Send                               |
| 9          | RT *          | Terminating Resistor for RD **              |
| 10         | RD (A')       | Receive Data                                |
| 11         | RD (B')       | Receive Data                                |
| 12         | SD (A)        | Send Data                                   |
| 13         | SD (B)        | Send Data                                   |
| 14         | RTS (B)       | Request To Send                             |
| 15         | CTS (A')      | Clear To Send                               |

- \* Signals available at the Connector but are not included in the RS-422 specification. SD (Send Data) and RD (Receive Data) are the same as TXD and RXD (used in the Series Six PLC). (A) and (B) are the same as - and + . A and B denote outputs, and A' and B' denote inputs.
- \*\* Termination resistance for the Receive Data (RD) signal needs to be connected only on units at the end of the lines. This termination is made on the Series 90 PLC products by connecting a jumper between pins 9 and 10 inside the 15-pin D-shell with the following exception. For Series 90-70 PLCs with Catalog Numbers IC697CPU731J, and IC697CPU771G and earlier the termination for RD at the PLC is implemented by a jumper between pins 9 and 11.

## Workmaster Serial Port

The Workmaster II industrial computer, RS-232 serial port is a 25-pin D-type male connector, and the early model Workmaster is a 9-pin male connector.

Figure C-2 shows the serial port connector layout for both computers. Table C-3 shows the pin numbering and signal assignment for both connector types.

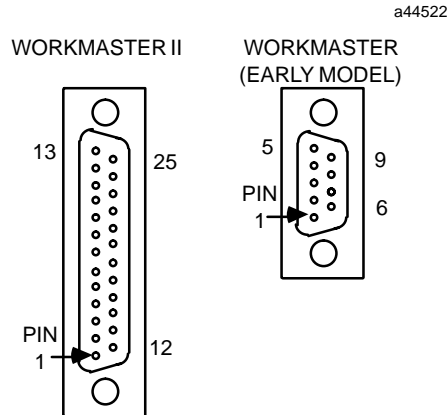

Figure C-2. Workmaster RS-232 Serial Port Connector Configuration

Table C-3. Workmaster RS-232 Serial Port Pins-out

| Workmaster II (25-pin connector) |        |                     |
|----------------------------------|--------|---------------------|
| Pin No.                          | Signal | Description         |
| 1                                |        | NC                  |
| 2                                | TD     | Transmit Data       |
| 3                                | RD     | Receive Data        |
| 4                                | RTS    | Request to Send     |
| 5                                | CTS    | Clear to Send       |
| 6                                |        | NC                  |
| 7                                | GND    | Signal Ground       |
| 8                                | DCD    | Data Carrier Detect |
| 9,10                             |        | NC                  |
| 11                               |        | Tied to line 20     |
| 12-19                            |        | NC                  |
| 20                               | DTR    | Data Terminal Ready |
| 21                               |        | NC                  |
| 22                               |        | Ring Indicate       |
| 23-25                            |        | NC                  |

| Workmaster (9-pin connector) |        |                     |
|------------------------------|--------|---------------------|
| Pin No.                      | Signal | Description         |
| 1                            |        | NC                  |
| 2                            | TD     | Transmit Data       |
| 3                            | RD     | Receive Data        |
| 4                            | RTS    | Request to Send     |
| 5                            | CTS    | Clear to Send       |
| 6                            |        | NC                  |
| 7                            | GND    | Signal Ground, 0V   |
| 8                            | DCD    | Data Carrier Detect |
| 9                            | DTR    | Data Terminal Ready |

NC = Not Connected

For more information about the Workmaster industrial computer serial port refer to the following manuals:

*GFK-0401 Workmaster II PLC Programming Unit Guide to Operation*

*GEK-25373 Workmaster Programmable Control Information Center Guide to Operation*

## IBM-AT/XT Serial Port

The IBM-AT, IBM-XT or compatible computer's RS-232 serial port is a 9-pin D-type male connector as shown in the figure below.

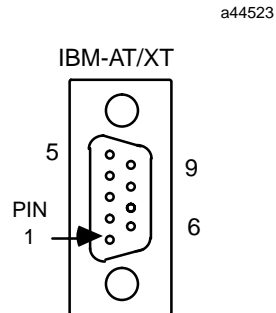

Figure C-3. IBM-AT/XT Serial Port

Table C-4. IBM-AT/XT Serial Port Pins-out

| IBM-AT Pin No. | Signal | Description         |
|----------------|--------|---------------------|
| 1              | DCD    | Data Carrier Detect |
| 2              | RD     | Receive Data        |
| 3              | TD     | Transmit Data       |
| 4              | DTR    | Data Terminal Ready |
| 5              | GND    | Signal Ground       |
| 6              |        | NC                  |
| 7              | RTS    | Request to Send     |
| 8              | CTS    | Clear to Send       |
| 9              |        | NC                  |

| IBM-XT Pin No. | Signal | Description         |
|----------------|--------|---------------------|
| 1              |        | NC                  |
| 2              | TD     | Transmit Data       |
| 3              | RD     | Receive Data        |
| 4              | RTS    | Request to Send     |
| 5              | CTS    | Clear to Send       |
| 6              |        | NC                  |
| 7              | GND    | Signal Ground       |
| 8              | DCD    | Data Carrier Detect |
| 9              | DTR    | Data Terminal Ready |

NC = Not Connected

## RS-232/RS-485 Converter

### IC690ACC901 Miniconverter Kit

This kit consists of an RS-422 to RS-232 miniconverter, a 6 foot (2 meter) serial cable, and a 9-pin to 25-pin serial port converter plug. This miniconverter is documented in Appendix F. This miniconverter has replaced the older, larger, obsolete IC690ACC900 converter.

### IC690ACC900 Obsolete Converter

The obsolete RS-232/RS-485 Converter (IC690ACC900) converts from RS-232 to RS-422/RS-485 communications. The converter has one 15-pin female D-type port, and one 25-pin female D-type port.

This converter is no longer available. Please substitute the IC690ACC901 miniconverter. Information about this converter is included in this manual for reference and troubleshooting purposes.

For detailed information on the converter, refer to Appendix D. Examples of serial cable diagrams, which include the converter, are provided in the remainder of this appendix..

## Serial Cable Diagrams

This section describes only a few of the many and various Point-to-Point, and Multidrop serial port connections for Series 90 PLCs.

In the point-to-point configuration only two devices can be connected to the same communication line. The communication line can be directly connected using RS-232 (50 feet, 15 meters maximum) or RS-485 (4000 feet, 1200 meters maximum). Modems can be used for longer distances.

### Note

The cable connector for the Series 90-70 and Series 90-30 PLCs serial port must be a right angle connector in order for the hinged door on the module to close properly. Refer to Table C-1 Connector/Cable Specification.

## RS-232 Point-to-Point Connections

The next three figures illustrate typical RS-232 point-to-point connection to Series 90 PLCs.

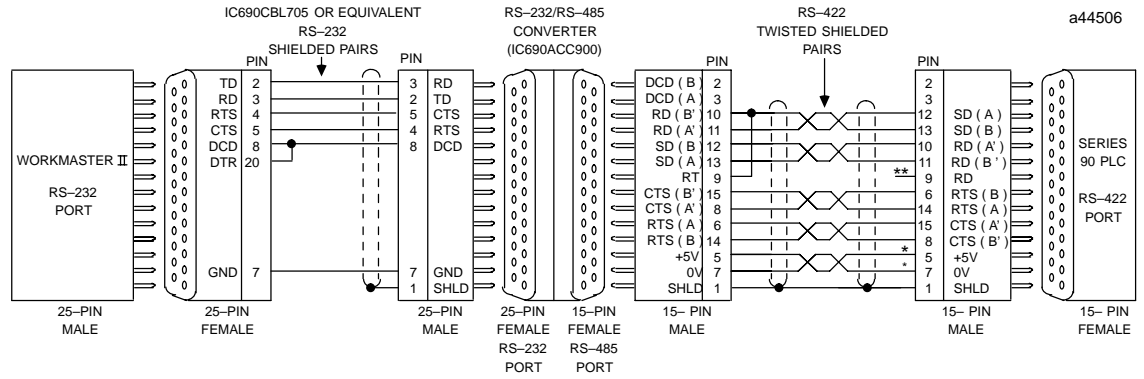

- \* POWER SOURCE FOR POINT-TO-POINT CONNECTION 10 FEET (3 METERS) ONLY. CONVERTER POWER SOURCE BEYOND 10 FEET (3 METERS) AND FOR MULTIDROP CONNECTION MUST BE EXTERNAL SOURCE.
- \*\* TERMINATION RESISTANCE FOR THE RECEIVE DATA (RD) SIGNAL NEEDS TO BE CONNECTED ONLY ON UNITS AT THE END OF THE LINES. THIS TERMINATION IS MADE ON THE SERIES 90 PLC PRODUCTS BY CONNECTING A JUMPER BETWEEN PIN 9 AND PIN 10 INSIDE THE 15-PIN D-SHELL WITH THE FOLLOWING EXCEPTION. FOR SERIES 90-70 PLCs, CATALOG NUMBERS IC697CPU731 AND IC697CPU771, THE TERMINATION FOR RD AT THE PLC IS IMPLEMENTED BY A JUMPER BETWEEN PIN 9 AND PIN 11.

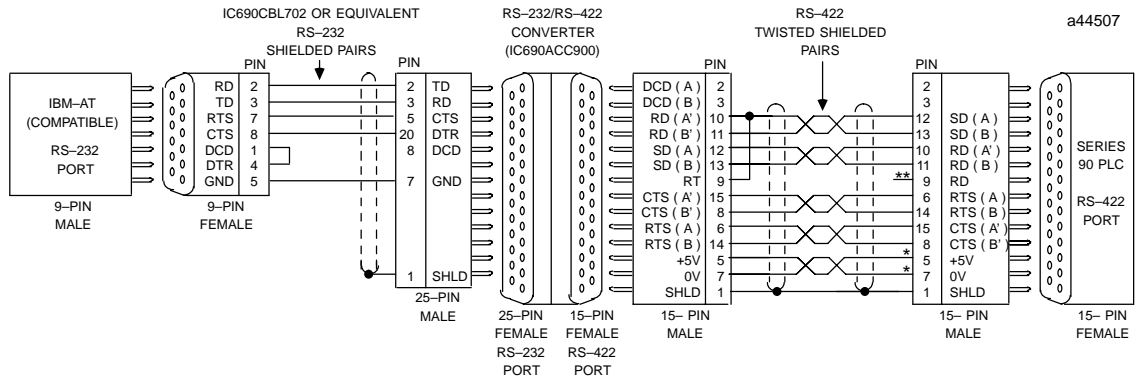

- \* POWER SOURCE FOR POINT-TO-POINT CONNECTION 10 FEET (3 METERS) ONLY. CONVERTER POWER SOURCE BEYOND 10 FEET (3 METERS) AND FOR MULTIDROP CONNECTION MUST BE EXTERNAL SOURCE.
- \*\* TERMINATION RESISTANCE FOR THE RECEIVE DATA (RD) SIGNAL NEEDS TO BE CONNECTED ONLY ON UNITS AT THE END OF THE LINES. THIS TERMINATION IS MADE ON THE SERIES 90 PLC PRODUCTS BY CONNECTING A JUMPER BETWEEN PIN 9 AND PIN 10 INSIDE THE 15-PIN D-SHELL WITH THE FOLLOWING EXCEPTION. FOR SERIES 90-70 PLCs, CATALOG NUMBERS IC697CPU731 AND IC697CPU771, THE TERMINATION FOR RD AT THE PLC IS IMPLEMENTED BY A JUMPER BETWEEN PIN 9 AND PIN 11.

Figure C-4. IBM-AT (compatibles) Personal Computer to Series 90 PLCs

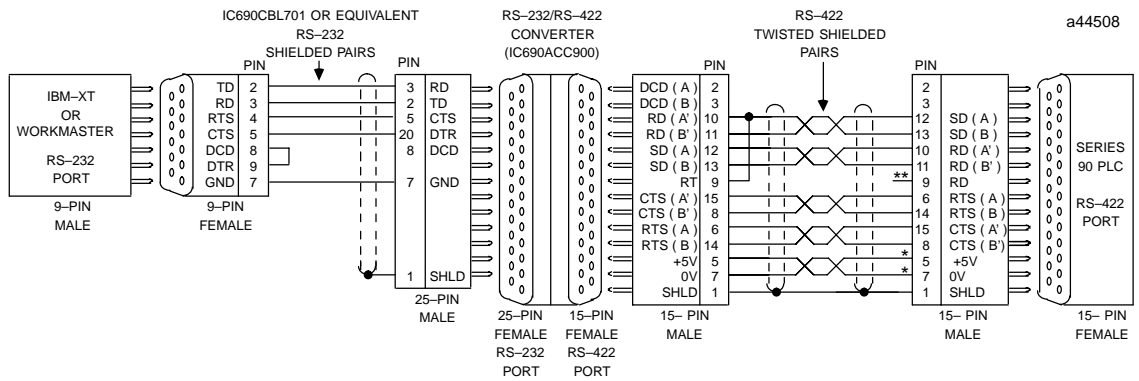

\* POWER SOURCE FOR POINT-TO-POINT CONNECTION 10 FEET (3 METERS) ONLY. CONVERTER POWER SOURCE BEYOND 10 FEET (3 METERS) AND FOR MULTIDROP CONNECTION MUST BE EXTERNAL SOURCE.

\*\* TERMINATION RESISTANCE FOR THE RECEIVE DATA (RD) SIGNAL NEEDS TO BE CONNECTED ONLY ON UNITS AT THE END OF THE LINES. THIS TERMINATION IS MADE ON THE SERIES 90 PLC PRODUCTS BY CONNECTING A JUMPER BETWEEN PIN 9 AND PIN 10 INSIDE THE 15-PIN D-SHELL WITH THE FOLLOWING EXCEPTION. FOR SERIES 90-70 PLCs, CATALOG NUMBERS IC697CPU731 AND IC697CPU771, THE TERMINATION FOR RD AT THE PLC IS IMPLEMENTED BY A JUMPER BETWEEN PIN 9 AND PIN 11.

Figure C-5. Workmaster or IBM-XT (compatibles) Personal Computer to Series 90 PLCs

## RS-422 Point-to-Point Connection

If your host device is equipped with a RS-422 card you can connect directly to Series 90 PLCs as illustrated in Figure C-7.

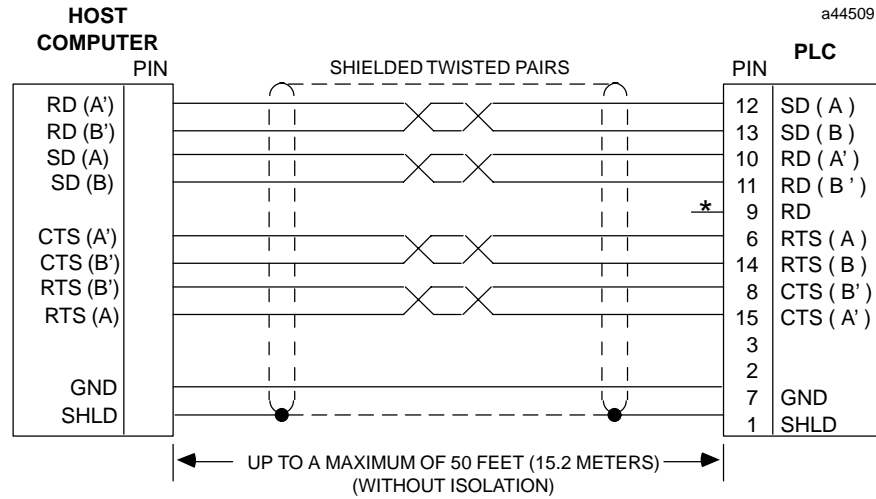

\* TERMINATION RESISTANCE FOR THE RECEIVE DATA (RD) SIGNAL NEEDS TO BE CONNECTED ONLY ON UNITS AT THE END OF THE LINES. THIS TERMINATION IS MADE ON THE SERIES 90 PLC PRODUCTS BY CONNECTING A JUMPER BETWEEN PIN 9 AND PIN 10 INSIDE THE 15-PIN D-SHELL WITH THE FOLLOWING EXCEPTION. FOR SERIES 90-70 PLCs, CATALOG NUMBERS IC697CPU731 AND IC697CPU771, THE TERMINATION FOR RD AT THE PLC IS IMPLEMENTED BY A JUMPER BETWEEN PIN 9 AND PIN 11.

Figure C-6. Typical RS-422, Host to PLC Connection, with Handshaking

## Multidrop Connections

In the multidrop configuration, the host device is configured as the master and one or more PLCs are configured as slaves. This method can be used when the maximum distance between the master and any slave does not exceed 4000 feet (1200 meters). This figure assumes good quality cables and a *moderately* noisy environment. A maximum of 8 slaves can be connected using RS-422 in a *daisy chain* or multidrop configuration. The RS-422 line must include handshaking and use wire type as specified in the “Cable and Connector Specifications” section.

The following illustrations shows wiring diagrams and requirements for connecting a Workmaster II or IBM-PS/2, Workmaster, IBM-AT/XT or compatible computer to Series 90 PLCs in an 8-wire multidrop, serial data configuration.

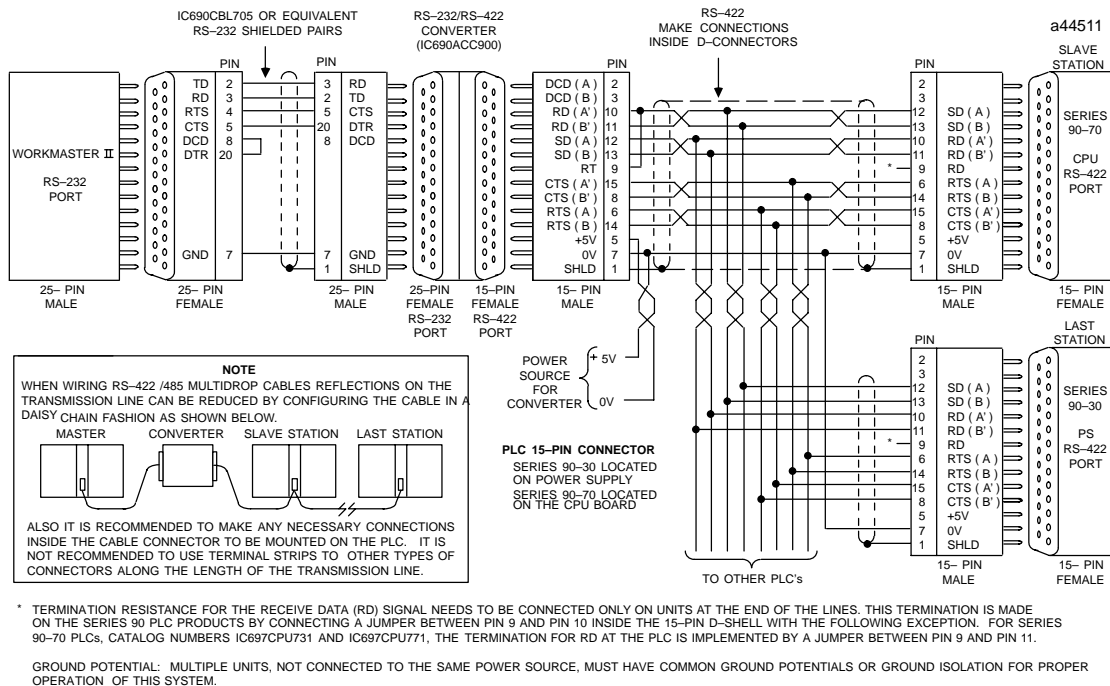

Figure C-7. Workmaster II/Series 90 PLC Multidrop Connection

### Note

The cable connector for the Series 90-70 serial port must be a right angle connector in order for the hinged door on the module to close properly. Refer to Table C-1, “Connector/Cable Specification.”

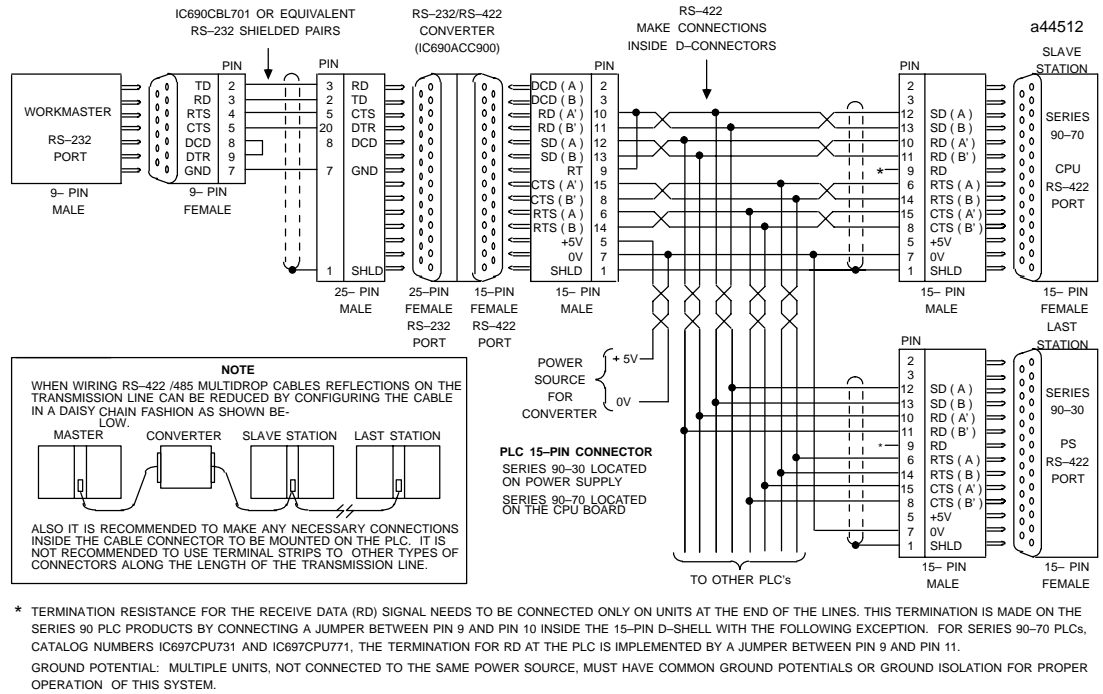

Figure C-8. Workmaster/Series 90 PLC Multidrop Connection

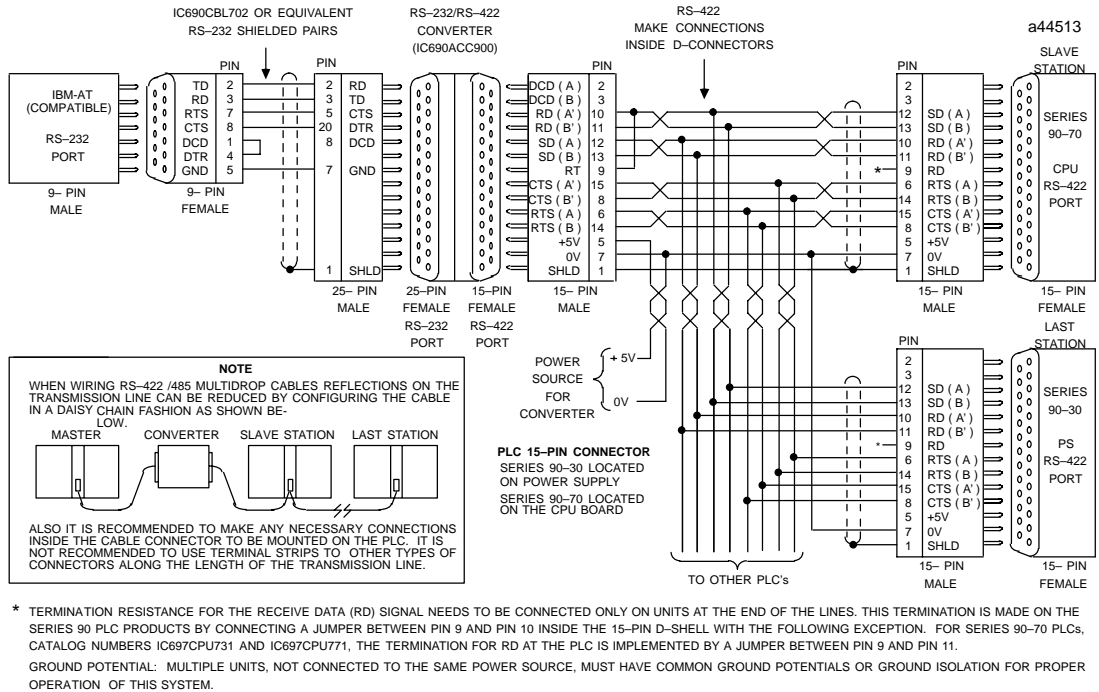

Figure C-9. IBM-AT/Series 90 PLC Multidrop Connection



# Appendix D

## IC690ACC900 Converter

*(Obsolete Product)*

---

---

[efesotomasyon.com](http://efesotomasyon.com)

**NOTE: This product is no longer available. This appendix is for reference for those already using this converter. We recommend the IC690ACC901 as a replacement for most applications (see Appendix F for details).**

This appendix provides a detailed description of the RS-422/RS-485 to RS-232 Converter (IC690ACC900) for the Series 90 Programmable Logic Controllers.

### Features

- Provides the Series 90 PLCs with an interface to devices that use the RS-232 interface.
- Allows connection to programming computer without a Work Station Interface board.
- Easy cable connection to either a Series 90-70 PLC or a Series 90-30 PLC.
- No external power needed; operates from +5 volt DC power on the Series 90 PLC backplane.
- Convenient, light weight self-contained unit.

### Functions

The RS-422/RS-485 to RS-232 Converter provides an RS-232 serial interface for the Series 90-70 and Series 90-30 PLCs, which have a built-in RS-422/RS-485 interface. Specifically, it provides a serial connection between a Series 90-30 or Series 90-70 PLC serial port and the serial port on the programming computer without the need for a Work Station Interface to be installed in the computer. The programming computer can be a Workmaster II computer, or IBM PS/2 or compatible computer.

### Location in System

The RS-422/RS-485 to RS-232 converter is a free-standing device which requires two cables as the connections between the PLC and the programmer. Its location is limited only by the length of the connecting cables as listed in the interface specifications (see

Table 5). The cable at the PLC end that connects to the RS-422/RS-485 connector on the converter can be up to 10 feet in length (without an external source of +5 VDC) and up to 1000 feet (300m) in length with an external source of +5 VDC. The cable from the RS-232 connector on the converter to the programming computer's serial port can be up to 50 feet (15m) in length.

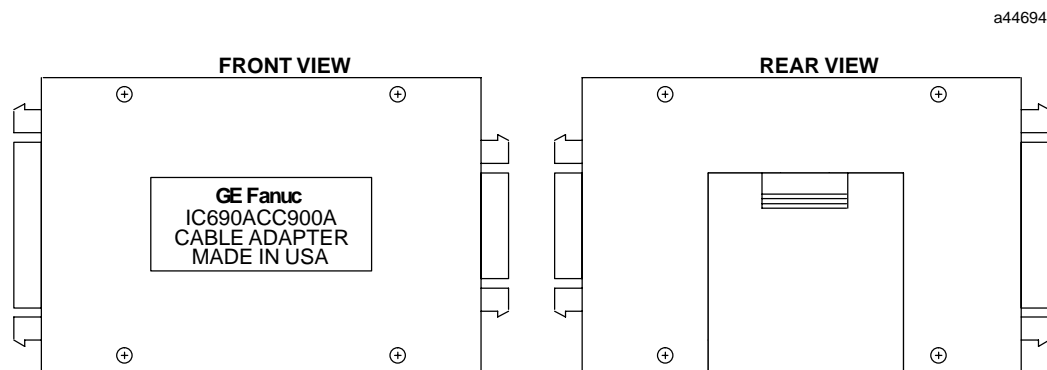

Figure D-1. Front and Rear View of Converter

## Installation

Installation of the RS-422/RS-485 to RS-232 Converter consists of connecting two cables. Select the proper cables for your installation. Prewired cables (see below) are available from GE Fanuc, or if cables of different lengths are required by your application, you can build your own cables. Specifications for building these cables are provided later in this appendix.

You do not need to connect an external source of power to the converter for a cable length of 10 feet, or less, since the necessary power connections of +5 VDC and signal ground are derived from the PLC's backplane bus through the cable which connects to the Series 90-30 or 90-70 PLC.

1. Select one of the three RS-232 compatible cables (10 feet in length) that will connect the programmer's (or other serial device) RS-232 serial port to the RS-232 port on the converter. The catalog numbers of these cables are: IC690CBL701 (use with Workmaster industrial computer, or IBM PC-XT or compatible personal computer), IC690CBL702 (use with IBM PC-AT or compatible personal computer), and IC690CBL705 (use with Workmaster II industrial computer, or IBM PS/2 or compatible personal computer).
2. A standard 6-foot cable (HHP compatible) is available to connect the RS-422/RS-485 port on the converter to the RS-485 port on the Series 90-30 or Series 90-70 PLC. The catalog number of this cable is IC693CBL303.

Installation of these cables should be done with the PLC powered-down.

- Connect the 25-pin male connector on the 10 foot cable to the 25-pin female connector on the converter.

- Connect the female connector (9-pin or 25-pin) on the opposite end of this cable to the male RS-232 connector (serial port) on the selected programming (or other serial) device. If you build your own cable, use a connector that is compatible with your serial device.
- Notice that both ends of the 6-foot RS-422/RS-485 compatible cable are the same; a 15-pin male connector is attached at both ends. Connect one end of this cable to the 15-pin female connector on the RS-422/RS-485 connector on the converter.
- Connect the other end of this cable to the 15-pin female connector, which interfaces to the RS-485 compatible serial port on the Series 90-30 or Series 90-70 PLC. For the Series 90-30 PLC, this connector is accessed by opening the hinged door on the power supply. The serial port connector for the Series 90-70 PLC is on the CPU module, and is accessed by opening the hinged door on the module.

## Cable Description

The serial connection to the Series 90-70 PLC (see Figure D-1) is to the RS-422/RS-485 compatible serial port connector, located at the bottom of the CPU module behind the hinged door, through an available 6 foot (2 meter) serial interface cable - IC693CBL303. Wiring information and recommended cable and connectors are provided for those who may want to build their own cable having a different length.

The serial connection to the Series 90-30 PLC is to the RS-485 compatible serial port connector located behind the hinged door on the right front of the power supply, through the same 6 foot serial interface cable, IC693CBL303, or equivalent, Figure D-2).

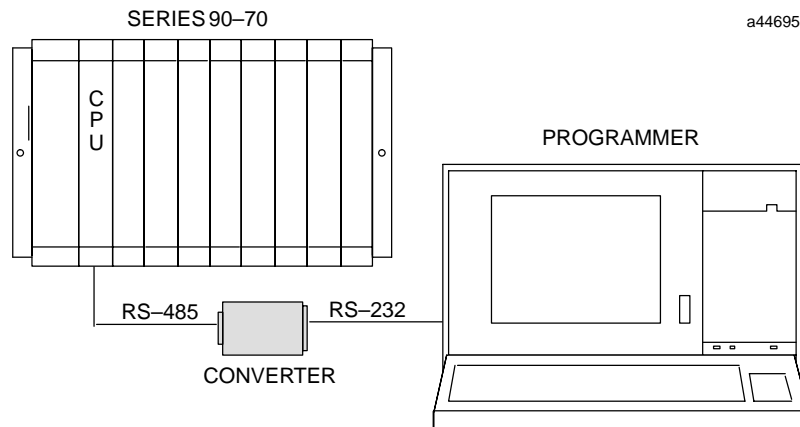

Figure D-2. Typical Configuration with Series 90-70 PLC

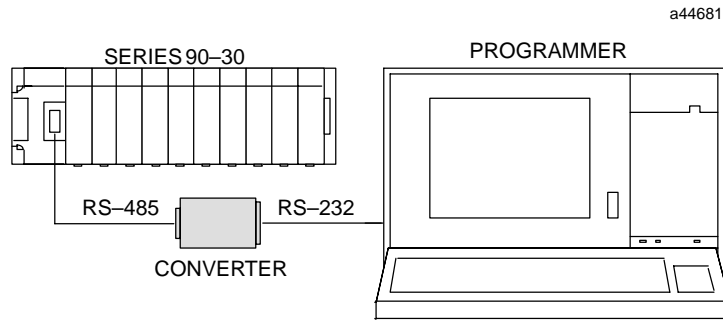

Figure D-3. Typical Configuration with Series 90-30 PLC

**RS-232 Interface Pin Assignments**

Pin assignments and signal definitions for the RS-232 interface are listed below.

Table D-1. RS-232 Interface for Converter

| Pin      | Signal Name | Function            | I/O |
|----------|-------------|---------------------|-----|
| 1        | Shield      | Cable shield        | -   |
| 2        | SD          | Transmitted Data    | Out |
| 3        | RD          | Received Data       | In  |
| 4        | RTS         | Request To Send     | Out |
| 5        | CTS         | Clear To Send       | In  |
| 6        | -           | No connection       | -   |
| 7        | SG          | Signal Ground       | -   |
| 8        | DCD         | Data Carrier Detect | In  |
| 9/19     | -           | No connection       | -   |
| 20       | DTR         | Data Terminal Ready | Out |
| 21 to 25 | -           | No connection       | -   |

## RS-422/RS-485 Interface Pin Assignments

Pin assignments and signal definitions for the RS-422/RS-485 interface are listed below.

Table D-2. RS-422/RS-485 Interface for Converter

| Pin | Signal Name  | Function                         | I/O |
|-----|--------------|----------------------------------|-----|
| 1   | Cable Shield |                                  |     |
| 2   | DCD(A)       | Differential Data Carrier Detect | Out |
| 3   | DCD(B)       | Differential Data Carrier Detect | Out |
| 4   | ATCH/        | Attach (used with HHP)           | n/a |
| 5   | +5 VDC       | Logic Power                      | In  |
| 6   | RTS(A)       | Differential Request To Send     | Out |
| 7   | SG           | Signal Ground, 0V                | In  |
| 8   | CTS(B')      | Differential Clear To Send       | In  |
| 9   | RT           | Resistor Terminator              | n/a |
| 10  | RD(A')       | Differential Receive Data        | In  |
| 11  | RD(B')       | Differential Receive Data        | In  |
| 12  | SD(A)        | Differential Send Data           | Out |
| 13  | SD(B)        | Differential Send Data           | Out |
| 14  | RTS(B)       | Differential Request To Send     | Out |
| 15  | CTS(A')      | Differential Clear To Send       | In  |

**Logic Diagram**

The following figure shows the logic diagram for the RS-422/RS-485 to RS-232 Converter.

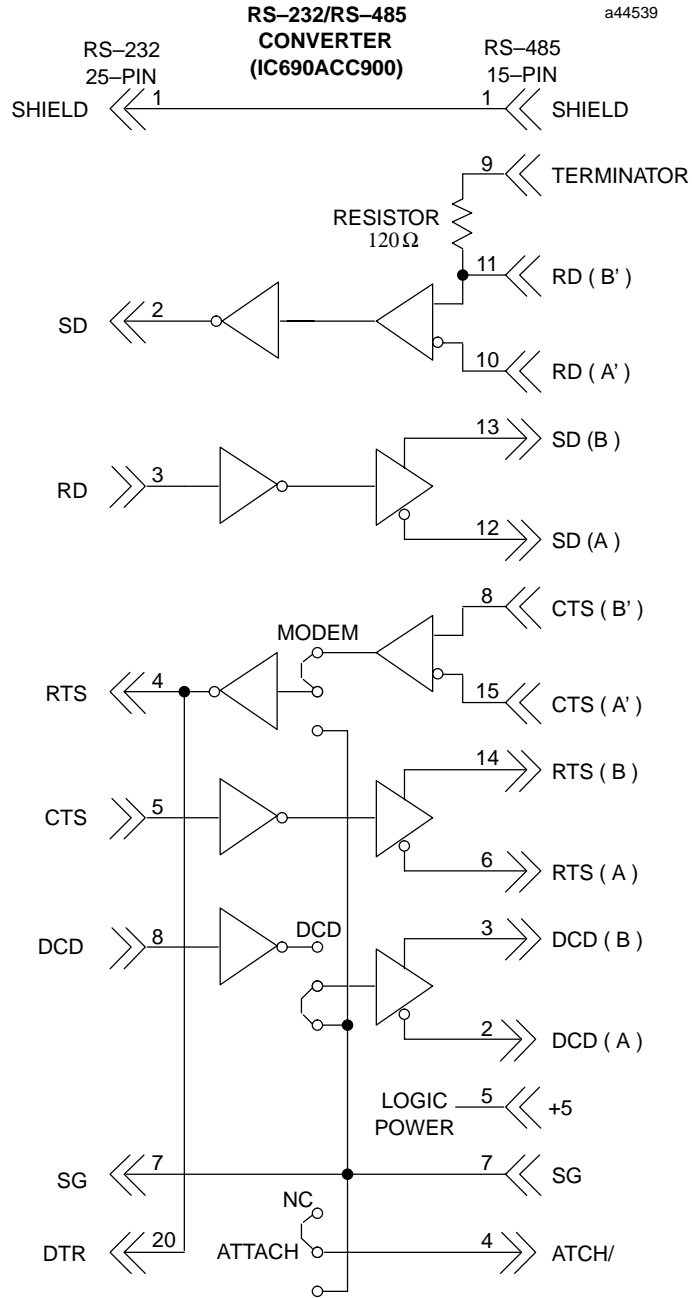

**Figure D-4. RS-422/RS-485 to RS-232 Converter Logic Diagram**

## Jumper Configuration

There are three jumper locations on the converter board for selection of user options. Each jumper position has three pins, as shown in the following illustration. These jumper positions, labeled JP2, JP3, and JP4, are accessed by removing the square plastic cover on the top of the converter. Configuration can be changed as required by carefully removing one or more of the jumpers with a pair of needle nose pliers and placing it on the desired pair of pins.

Refer to the description of these selectable jumper positions in the following table and place the jumper on the selected pair of pins. The pin numbers are 1, 2, and 3. Default jumper locations are indicated by a rectangle around the pins to be jumpered for each position. The default pin numbers are 1 and 2.

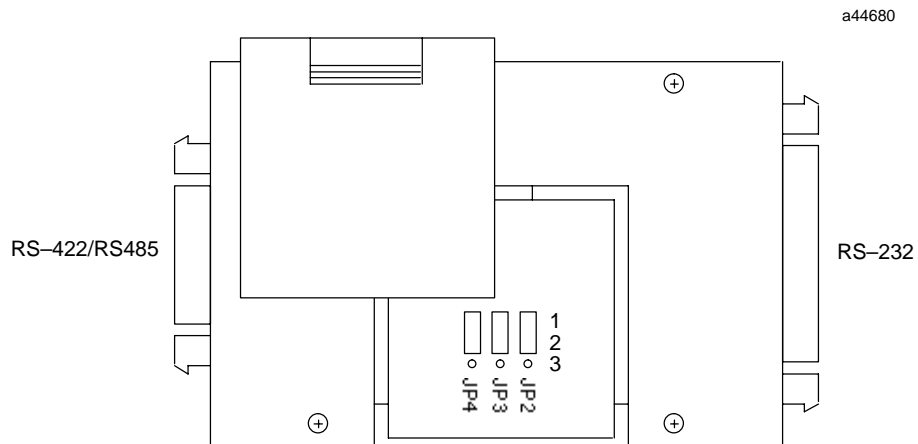

Figure D-5. Location of Jumpers for User Options

**Table D-3. Jumper Configuration for RS-422/RS-485 to RS-232 Converter**

| <b>Jumper Position</b> | <b>Label</b> | <b>Jumper Position</b> | <b>Description †</b>  |
|------------------------|--------------|------------------------|---|
| JP2                    | DCD          | 1 2 3                  | Default position 1 and 2 is used when the device communicating with the PLC does not supply the Carrier Detect signal. JP2 forces the DCD signal active on the RS-485 port. |
|                        |              | 1 2 3                  | Use jumper positions 2 and 3 if the device does supply the Carrier Detect signal. This allows the programming device to control DCD.  |
| JP3                    | MODEM        | 1 2 3                  | Default position 1 and 2 is used when an attached Modem does not require the Clear To Send (CTS) signal. This allows the programming device to control the RTS signal.      |
|                        |              | 1 2 3                  | Jumper positions 2 and 3 are used when the attached Modem does require the CTS signal (most modems require this signal). Forces RTS to be continually active.               |
| JP4                    | ATTACH       | 1 2 3                  | Default position 1 and 2 is used for most applications communicating with the PLC via a serial programming device.  |
|                        |              | 1 2 3                  | Jumper positions 2 and 3 are used if the device communicating with the PLC is intended to emulate the HHP protocol.   |

† Refer to the documentation for your serial device for signal requirements.

## Example of Cable Configurations

Examples of cable configurations required when using the converter can be found in Appendix C. Specifications for the converter are shown in the following table.

Table D-4. Specifications for IC690ACC900 Converter

|   |   |
|---|---|
| <b>Power Requirements:</b>                |   |
| <b>Voltage</b>                            | 5 volts DC, +5%   |
| <b>Current</b>                            | 170 mA, ±5%   |
| <b>RS-422/RS-485 Interface Cables:</b>    |   |
| <b>Maximum cable length</b>               | 1000 feet(300m)   |
| <b>Cable Type: †</b>                      |   |
| <b>6 feet (2m)</b>                        | Cable type: Belden 9508, AWG #24 (0.22 mm <sup>2</sup> )  |
| <b>30 feet (10m) ‡</b>                    | Cable type: Belden 9309, AWG #22 (0.36 mm <sup>2</sup> )  |
| <b>≥30 feet, up to 1000 feet (300m) ‡</b> | Same cable as for 30 feet.  |
| <b>Connector Type</b>                     | 15-pin D-type Male Subminiature (both ends)   |
| <b>RS-232 Interface Cable:</b>            |   |
| <b>Maximum cable length</b>               | 50 feet (15m)   |
| <b>Up to 50 feet (15m)</b>                |   |
| <b>Connector Type</b>                     | 25-pin D-type Female Subminiature (converter end) 9-pin, 15-pin, or 25-pin (depending on type of connector on your serial device) D-type Female Subminiature (programming device end) |

† Catalog numbers are provided as suggestions only. Any cable having the same electrical characteristics is acceptable. It is strongly recommended that you use stranded wire. Since it is sometimes hard to find a cable with the desired number of twisted pairs (the Belden 9309 has an extra pair), you may end up with a cable with extra pairs.

‡ For distances over 10 feet, the +5 volt DC logic power source must be provided externally by connecting an external power supply to the +5V and SG (0V) connections at the converter end of the cable. **The +5V pin at the PLC connector end of the cable must not be connected to the cable.** The +5V and SG connections from the external power supply must be isolated from its own power line ground connection. Ensure that there is no connection between the external supply and the PLC except the SG cable connection.

# Appendix *E*

## *IC655CCM590 Isolated Repeater/Converter* *(Obsolete Product)*

[efesotomasyon.com](http://efesotomasyon.com)

**NOTE: This product is no longer available. This appendix is for reference by those already using this product. It has been replaced by catalog number IC690ACC903 (see Appendix G for details).**

This appendix describes how to use the *Isolated Repeater/Converter* (IC655CCM590) with Series 90 PLCs. The following topics are covered in this appendix.

- Description of the Isolated Repeater/Converter
- System Configurations
- Cable Diagrams

### Note

The catalog number for the Isolated Repeater/Converter was previously IC630CCM390.

### Description of the Isolated Repeater/Converter

The Isolated Repeater/Converter (IC655CCM590) can be used for the following purposes.

- To provide ground isolation where a common ground cannot be established between components.
- To boost RS-422 signals for greater distance and more drops.
- To convert signals from RS-232 to RS-422 or RS-422 to RS-232.

The figure on the next page shows the appearance of the unit and the location of features that are of interest to the user.

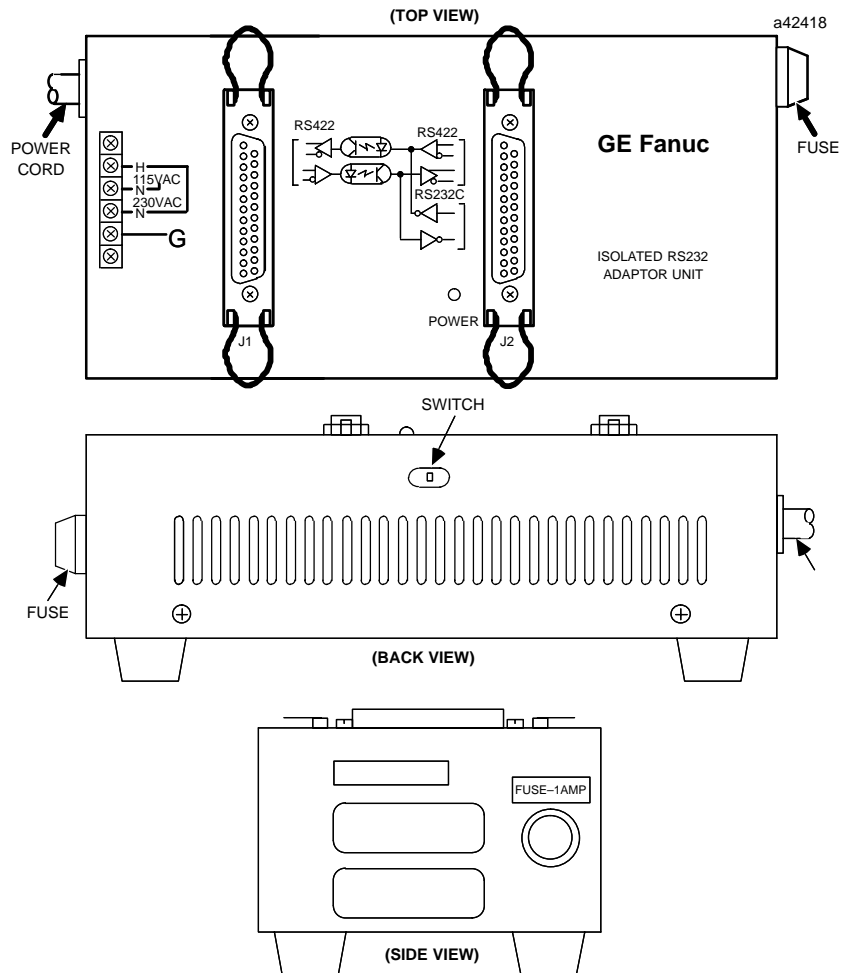

**Figure E-1. Isolated/Repeater Converter**

Items of interest to the user on the Isolated Repeater/Converter are described below.

- Two 25-pin female D-type connectors (Two 25-pin male, D-type connectors (solder pot), are included for user cabling.)
- 115/230VAC power connection (internal) 4-position terminal block.
- Fused 1 Amp power protection.
- Power ON (green) indicator LED.
- Three-position toggle switch, recessed in the back of the unit, is set according to the system configurations shown later in this appendix.

### Logic Diagram of the Isolated Repeater/Converter

The figure below provides a functional look at the unit. Note the 3-position switch for controlling the J1 port transmitters. This switch is discussed in *System Configurations* later in this appendix.

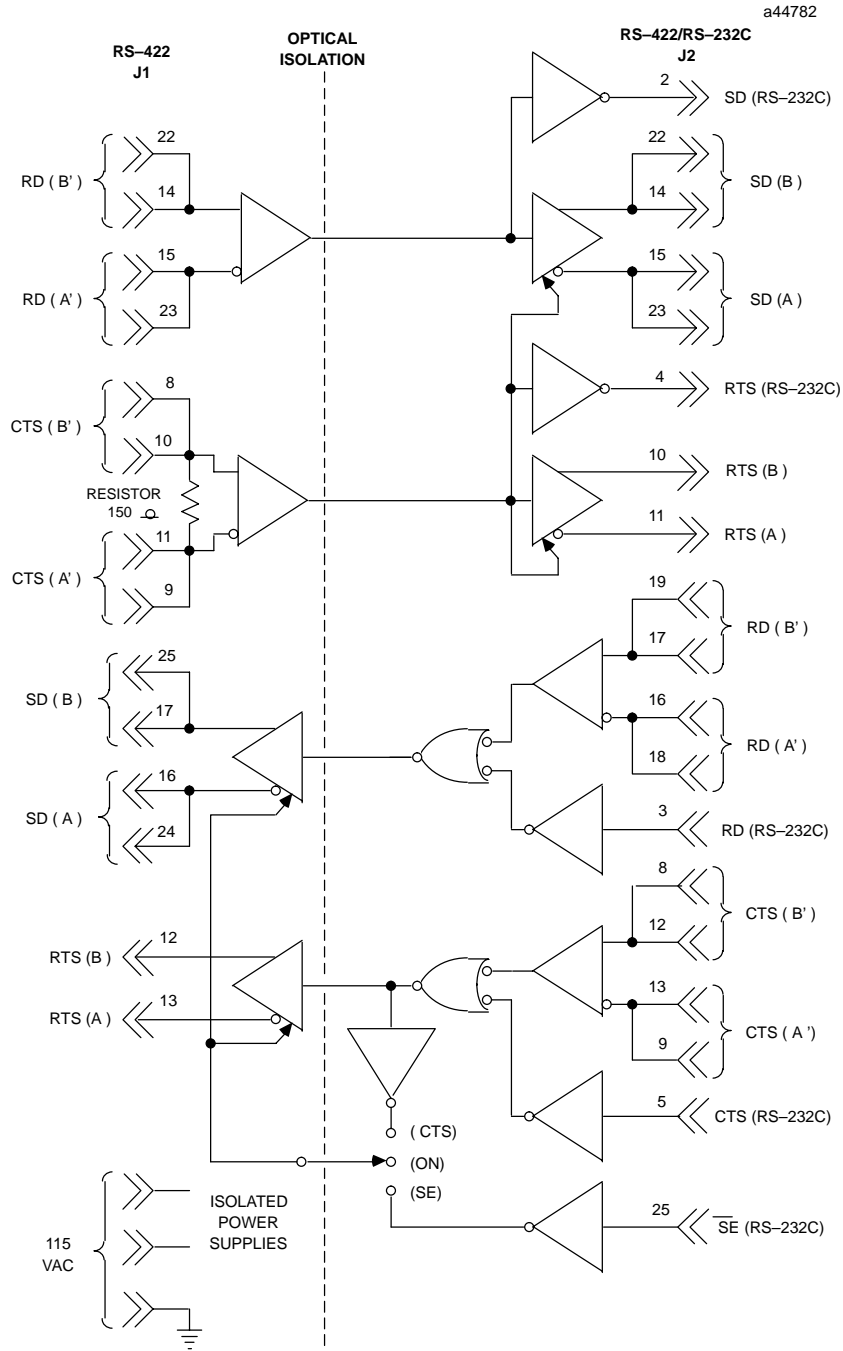

Figure E-2. RS-422 Isolated Repeater/RS-232 Converter Logic Diagram

**Note**

All inputs are biased to the inactive state. Inputs left unconnected will produce a binary 1 (OFF) state on the corresponding output.

**Pin Assignments for the Isolated Repeater/Converter**

**Table E-1. Isolated Repeater/Converter Pin Assignments**

| J1 RS-422 Port (25-pin female connector) |         |                                      | J2 RS-422/RS-232 Port (25-pin female connector) |         |                                      |
|--|---------|--------------------------------------|---|---------|--------------------------------------|
| Pin                                      | Signal  | Description                          | Pin   | Signal  | Description                          |
| 1  |         | NC                                   | 1   |         | NC                                   |
| 2  |         | NC                                   | 2   | SD      | Send Data (RS-232)                   |
| 3  |         | NC                                   | 3   | RD      | Receive Data (RS-232)                |
| 4  |         | NC                                   | 4   | RTS     | Request to Send (RS-232)             |
| 5  |         | NC                                   | 5   | CTS     | Clear to Send (RS-232)               |
| 6  |         | NC                                   | 6   |         | NC                                   |
| 7  | 0V      | Ground Connection                    | 7   | 0V      | Ground Connection                    |
| 8  | CTS(B') | Clear to Send (Optional Termination) | 8   | CTS(B') | Clear to Send Optional Termination   |
| 9  | CTS(A)  | Clear to Send (Optional Termination) | 9   | CTS(A)  | Clear to Send (Optional Termination) |
| 10                                       | CTS(B') | Clear to Send                        | 10  | RTS(B)  | Request to Send                      |
| 11                                       | CTS(A)  | Clear to Send                        | 11  | RTS(A)  | Request to Send                      |
| 12                                       | RTS(B)  | Request to Send                      | 12  | CTS(B') | Clear to Send                        |
| 13                                       | RTS(A)  | Request to Send                      | 13  | CTS(A)  | Clear to Send                        |
| 14                                       | RD(B')  | Receive Data                         | 14  | SD(B)   | Send Data                            |
| 15                                       | RD(A)   | Receive Data                         | 15  | SD(A)   | Send Data                            |
| 16                                       | SD(A)   | Send Data                            | 16  | RD(A)   | Receive Data                         |
| 17                                       | SD(B)   | Send Data                            | 17  | RD(B')  | Receive Data                         |
| 18                                       |         | NC                                   | 18  | RD(A')  | Receive Data (Optional Termination)  |
| 19                                       |         | NC                                   | 19  | RD(B')  | Receive Data (Optional Termination)  |
| 20                                       |         | NC                                   | 20  |         | NC                                   |
| 21                                       |         | NC                                   | 21  |         | NC                                   |
| 22                                       | RD(B')  | Receive Data                         | 22  | SD(B)   | Send Data (Optional Termination)     |
| 23                                       | RD(A)   | Receive Data                         | 23  | SD(A)   | Send Data (Optional Termination)     |
| 24                                       | SD(A)   | Send Data                            | 24  |         | NC                                   |

NC=No Connection

SD (Send Data) and RD (Receive Data) are the same as TXD and RXD (used in the Series Six PLC).

(A) and (B) are the same as - and + A and B denote outputs, and A' and B' denote inputs.

**Caution**

**The signal ground connections (pin 7 on each connector) must be made between the Isolated Repeater/Converter and the PLC for J1, and the Isolated Repeater/Converter and the host computer for J2.**

**Pin 7 of the J1 port is connected to the metal shell of the J1 connector. Pin 7 of the J2 port is connected to the metal shell of the J2 connector. These two signal ground connections are isolated from each other and from the power system ground (green wire on the terminal block). To maintain proper isolation, these signal grounds cannot be tied together.**

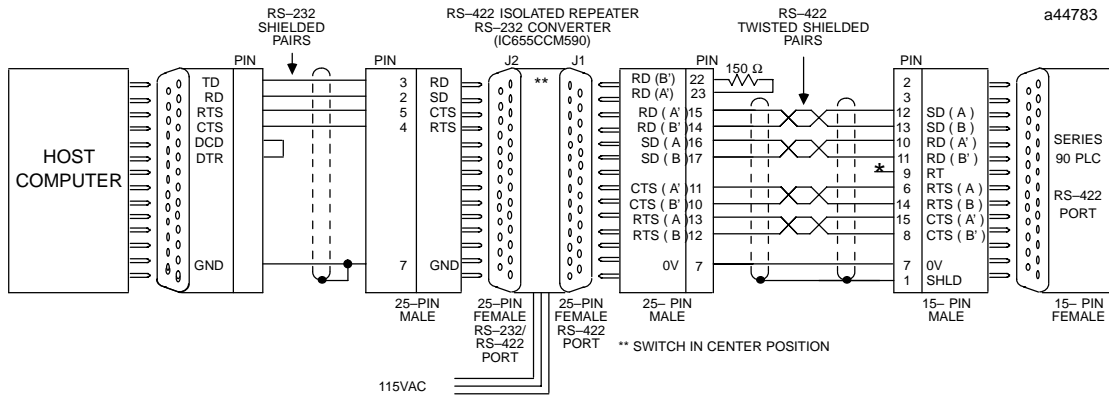

\* TERMINATION RESISTANCE FOR THE RECEIVE DATA (RD) SIGNAL NEEDS TO BE CONNECTED ONLY ON UNITS AT THE END OF THE LINES. THIS TERMINATION IS MADE ON THE SERIES 90 PLC PRODUCTS BY CONNECTING A JUMPER BETWEEN PIN 9 AND PIN 10 INSIDE THE 15-PIN D-SHELL WITH THE FOLLOWING EXCEPTION. FOR SERIES 90-70 PLCs, CATALOG NUMBERS IC697CPU731 AND IC697CPU771, THE TERMINATION FOR RD AT THE PLC IS IMPLEMENTED BY A JUMPER BETWEEN PIN 9 AND PIN 11.

Figure E-3. Example RS-422 Isolated Repeater/RS-232 Converter Connection

## System Configurations

The figures below show various ways you can connect the Isolated Repeater/Converter to convert signals, expand the number of drops, and obtain greater distance. Any system configuration can be reduced to a minimum number of cables each covering a part of the overall system configuration. The following examples of system configurations refer to these cables as Cables A through E which are described in *Cable Diagrams* later in this section.

**Downstream and Upstream Contention.** In this section, simple multidrop configurations are those where a single Isolated Repeater/Converter is used. Complex multidrop configurations contain one or more multidrop sections where an Isolated Repeater/Converter is included as one of the drops. In both simple and complex multidrop configurations, the transmitters directed downstream from the master can be on at all times. There will be no contention for the communication line because only one device (the master) transmits downstream.

In simple multidrop configurations, there will be no contention when transmitting upstream as long as devices tri-state their drivers when idle and turn them on only when they have something to transmit. This is the case for the Series 90-70 and Series 90-30 CMMs.

In complex multidrop configurations, however, special steps must be taken to switch the upstream transmitters of the Isolated Repeater/Converter.

**Switching Upstream Transmitters.** For the RS-422 drivers to be active at the J2 port of the Isolated Repeater/Converter, the RTS input at J1 must be true. The state of the RS-422 drivers at the J1 port depends on the position of the switch on the unit. When the switch is in the center position, the J1 transmitters will always be turned on. When the switch is in the CTS position, (toward the power cable), then either the RS-232 or RS-422 CTS signal must be true to turn on the J1 drivers.

### Note

Note the position of the switch on the Isolated/Repeater Converter in the system configurations below.

**Simple Multidrop Configuration**

This configuration shows how to connect a single Isolated Repeater/Converter for signal conversion or greater distance.

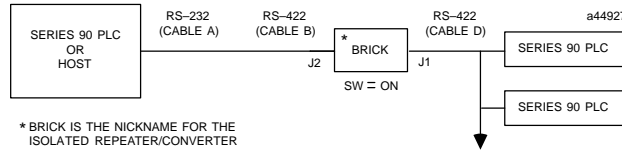

**Figure E-4. Simple System Configuration Using the Isolated Repeater/Converter**

**Complex Multidrop Configuration**

This configuration shows how to connect multiple Isolated Repeater/Converters for signal conversion, greater distance, and more drops.

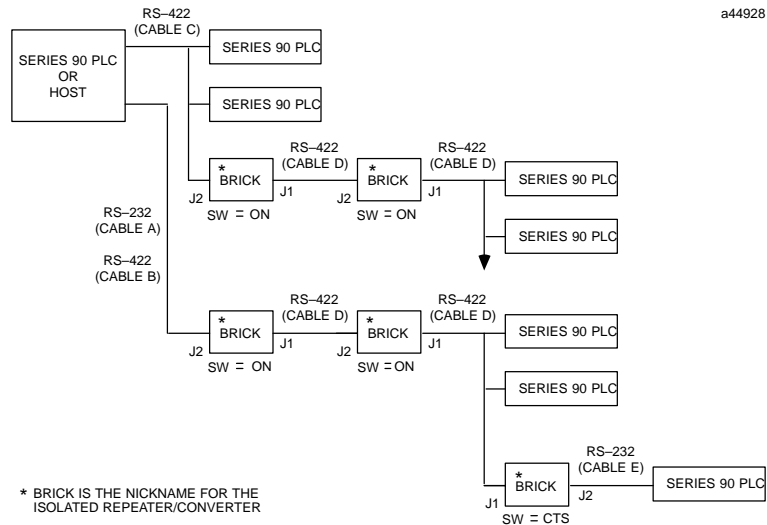

**Figure E-5. Complex System Configuration Using the Isolated Repeater/Converter**

**Rules for Using Repeater/Converters in Complex Networks**

When designing a complex multidrop network including PLCs and RS-422 repeater/converters (bricks), the following rules apply:

**Rule 1:** When using a brick as a repeater, port J2 should always be directed toward the host device, and Port J1 should always be directed away from the host device. The switch located on the side of the brick should always be in the center position (ON). The only case in which Port J1 is directed toward the host is when the brick is used as a converter (RS-232) at the slave. The switch is in the right position (CTS).

**Rule 2:** If a Series 90 CMM slave device is located downstream of a brick, set the configuration of the CMM serial port to NONE flow control with a 10 ms Modem Turnaround Delay (Applies to CCM, SNP, and SNP-X protocols only).

**Rule 3:** Do not place more than 3 bricks in a single communication path between the host and the slave devices.

Cable Diagrams

The cable diagrams below are referred to as Cables A-E from the system configurations in the previous figures. These diagrams show the principles for constructing your own cables and can be modified to fit your specific application.

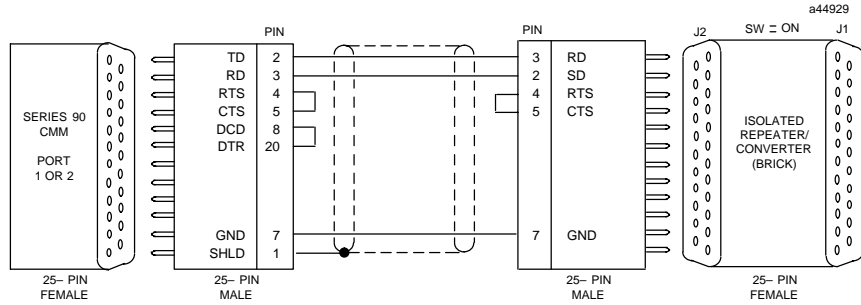
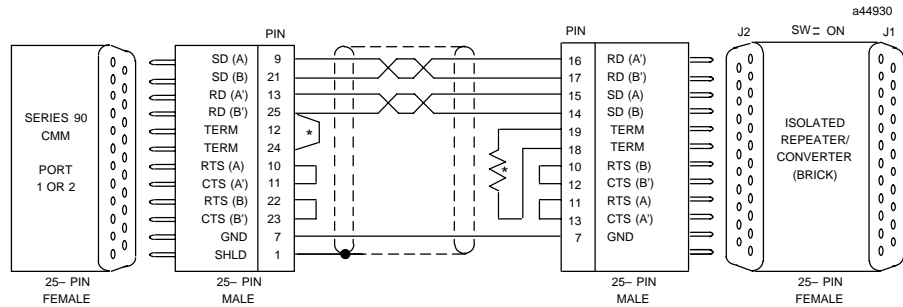
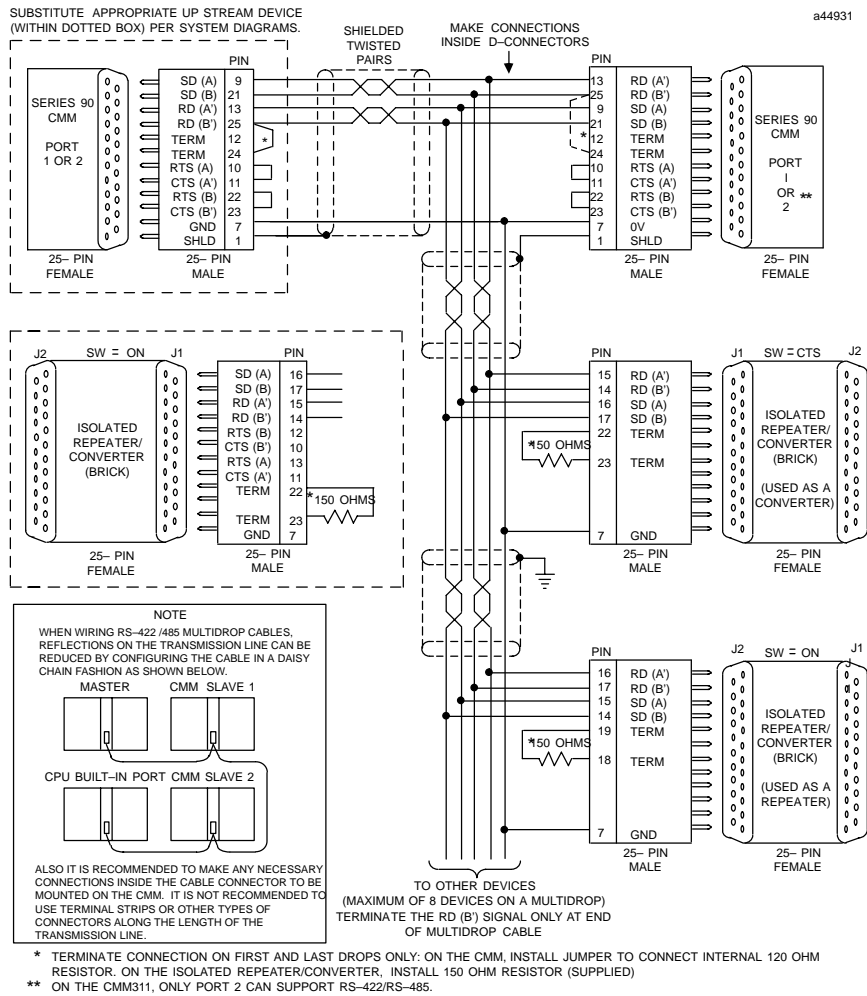

Figure E-6. Cable A; RS-232 CMM To Converter



\* TERMINATE CONNECTION: ON THE CMM, INSTALL JUMPER TO CONNECT INTERNAL 120 OHM RESISTOR. ON THE ISOLATED REPEATER/ CONVERTER, INSTALL 150 OHM RESISTOR (SUPPLIED).

Figure E-7. Cable B; RS-422 CMM To Converter



**Figure E-8. Cable C; RS422 Twisted Pair**

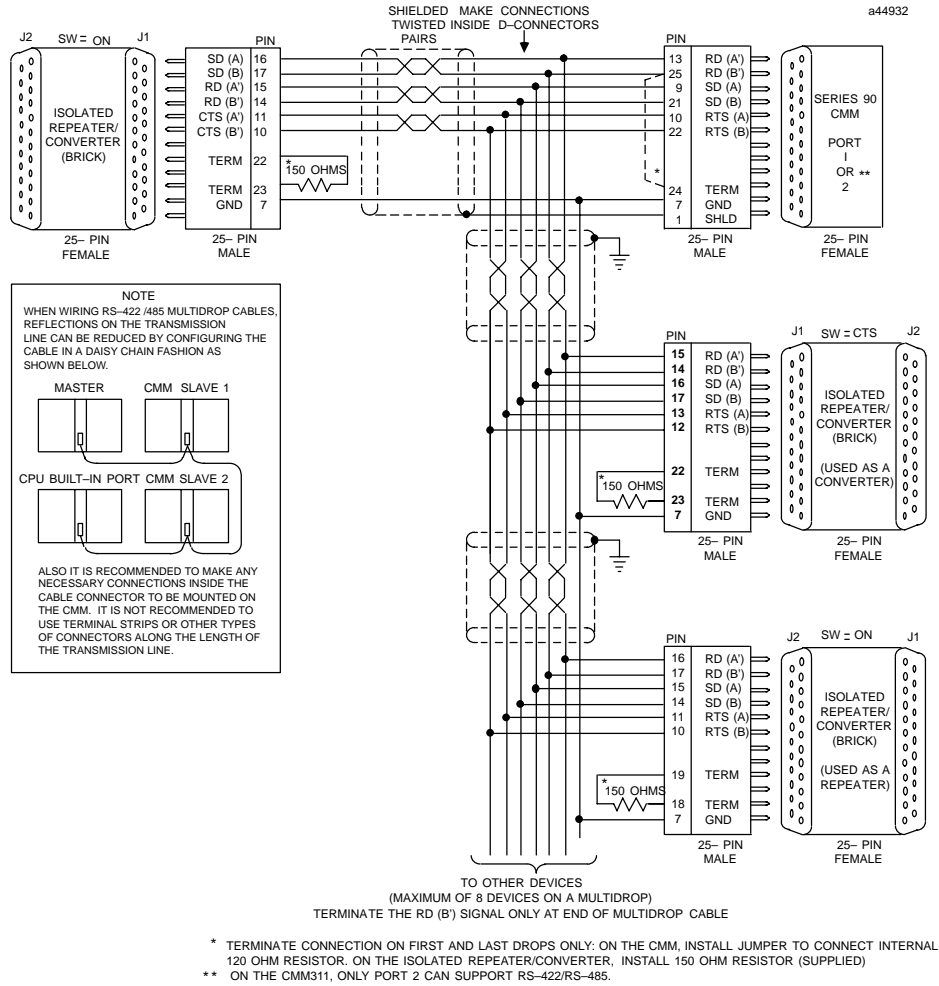

Figure E-9. Cable D; RS-422 Twisted Pair

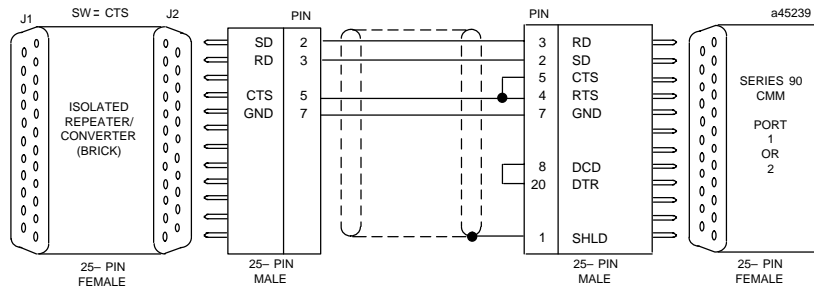

Figure E-10. Cable E; RS-232 Converter to CMM

## Description of Miniconverter

The Miniconverter Kit (IC690ACC901) consists of an RS-422 (SNP) to RS-232 Miniconverter, a 6 foot (2 meter) serial extension cable, and a 9-pin to 25-pin Converter Plug assembly. The 15-pin SNP port connector on the Miniconverter plugs directly into the serial port connector on the Series 90-30 power supply, Series 90-70 CPU or Series 90-20 CPU. The 9-pin RS-232 port connector on the Miniconverter connects to an RS-232 compatible device.

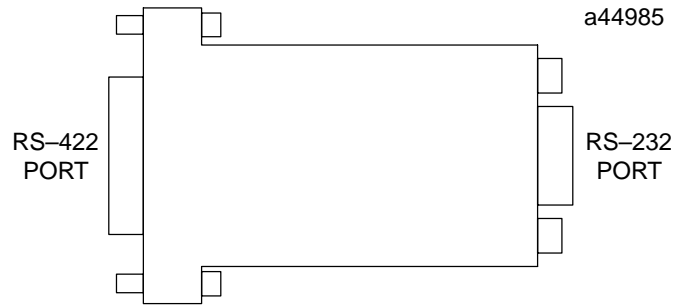

Figure F-1. Series 90 SNP to RS-232 Miniconverter

When used with an IBM PC-AT, or compatible computer, one end of the extension cable plugs into the Miniconverter's 9-pin serial port connector, the other end plugs into the 9-pin serial port of the computer. The Converter plug (supplied with kit) is required to convert the 9-pin serial port connector on the Miniconverter to the 25-pin serial port connector on the GE Fanuc Workmaster II computer, or an IBM PC-XT or PS/2 Personal Computer.

*The GE Fanuc Workmaster computer requires an additional adapter (not supplied with kit - please contact your local GE Fanuc PLC distributor) for use with the Miniconverter.*

## Pin Assignments

The pinouts of the Miniconverter are shown in the following two tables. The first table shows the pinout for the RS-232 port, the second table shows the RS-422 port.

### Pin Assignments, RS-232 Port

Table F-1 is for the RS-232 port. The direction of signal flow is with respect to the Miniconverter.

**Table F-1. Miniconverter RS-232 Port**

| <b>Pin</b> | <b>Signal Name</b>    | <b>Direction</b> |
|------------|-----------------------|------------------|
| 2          | SD - Send Data        | Output           |
| 3          | RD - Receive Data     | Input            |
| 5          | GND - Ground          | n/a              |
| 7          | CTS - Clear To Send   | Input            |
| 8          | RTS - Request To Send | Output           |

The pinouts were chosen to allow direct connection (using a straight through, or 1 to 1 cable (as provided with kit)) to the IBM PC-AT. Most IBM compatible computers equipped with an RS-232 port will provide a pinout compatible with the one shown above.

### Pin Assignments, RS-422 Port

Table F-2 is the pinout for the Miniconverter's RS-422 serial port. The direction of signal flow is also with respect to the Miniconverter.

**Table F-2. Miniconverter RS-422 Port**

| <b>Pin</b> | <b>Signal Name</b>       | <b>Direction</b> |
|------------|--------------------------|------------------|
| 1          | SHLD - Shield            | n/a              |
| 5          | +5 VDC - Power           | Input            |
| 6          | CTS(A) - Clear To Send   | Input            |
| 7          | GND - Ground             | n/a              |
| 8          | RTS(B) - Request To Send | Output           |
| 9          | RT - Receive Termination | Output           |
| 10         | SD(A) - Send Data        | Output           |
| 11         | SD(B) - Send Data        | Output           |
| 12         | RD(A') - Receive Data    | Input            |
| 13         | RD(B') - Receive Data    | Input            |
| 14         | CTS(B') Clear To Send    | Input            |
| 15         | RTS(A) - Request To Send | Output           |

## System Configurations

The Miniconverter can be used in a point-to-point configuration as described above, or in a multidrop configuration with the host device configured as the master and one or more PLCs configured as slaves.

The multidrop configuration requires a straight through (1 to 1) cable from the Miniconverter's RS-422 port to the first slave PLC's SNP port. Other slaves will require a daisy chain connection between slaves. A maximum of eight devices can be connected in an RS-422 multidrop configuration. All of the devices must have a common ground. If ground isolation is required, you can use the GE Fanuc Isolated Repeater/Converter (IC655CCM590) in place of the Miniconverter.

When using the Miniconverter with a modem connection, it may be necessary to jumper RTS to CTS (consult the user's manual for your modem).

### Cable Diagrams (Point-To-Point)

When connecting the Miniconverter to IBM PC and compatible computers with hardware handshaking, the following cable connections should be used.

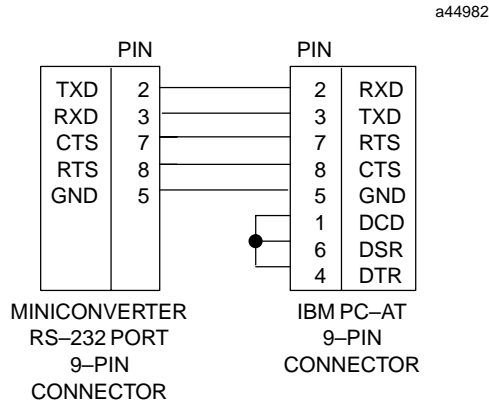

Figure F-2. Miniconverter to PC-AT

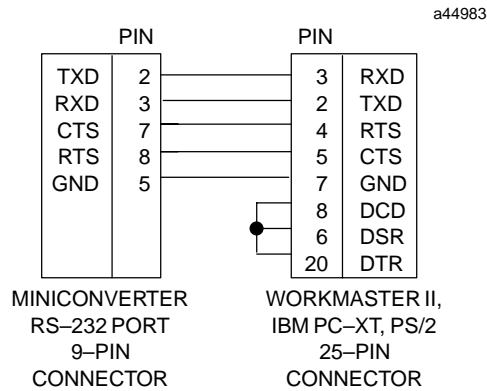
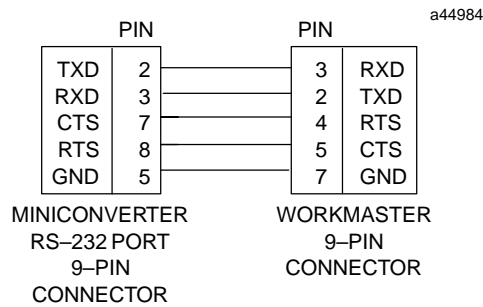

Figure F-3. Miniconverter to Workmaster II, PC-XT, PS/2



Note: Additional adapter required

Figure F-4. Miniconverter to 9-Pin Workmaster or PC-XT Computer

**Table F-3. Miniconverter Specifications**

|                                |   |
|--------------------------------|---|
| <b>Mechanical:</b>             |   |
| <b>RS-422</b>                  | 15-pin D shell male for direct mounting to Series 90 serial port.   |
| <b>RS-232</b>                  | 9-pin D shell male for connection to RS-232 serial port of a Workmaster II computer or Personal Computer. |
| <b>Electrical and General:</b> |   |
| <b>Voltage Supply</b>          | +5 VDC (supplied by PLC power supply)   |
| <b>Typical Current</b>         | Version A (IC690ACC901A) - 150 mA<br>Version B (IC690ACC901B) - 100 mA                                    |
| <b>Operating Temperature</b>   | 0 to 70° C (32 to 158° F)   |
| <b>Baud Rate</b>               | 38.4K Baud maximum  |
| <b>Conformance</b>             | EIA-422 (Balanced Line) or EIA-423 (Unbalanced Line)  |
| <b>Ground Isolation</b>        | Not provided  |

## IC690ACC903 Port Isolator

[efesotomasyon.com](http://efesotomasyon.com)

The IC690ACC903 RS-485 Port Isolator replaces the IC655CMM590 Isolated Repeater/Converter (also referred to as the “Brick”). The device features 500 volts of isolation in a compact package servicing all IC693, IC697, and IC200 PLC product lines. The product connects directly to an RS-485 serial port or through a short extender cable provided with the device. The extension cable is intended for use in applications where direct connection to the port is obstructed by surrounding equipment or when it is not acceptable for the device to protrude from a PLC module. The Port Isolator can operate in either single- or multi-drop mode, which is selected by a slide switch on the top of the module.

The Port Isolator provides the following features:

- Four opto-isolated signal channels: SD, RD, RTS, and CTS
- Electrical compatibility with RS-485
- Single- or multi-drop operation
- Input termination consistent with standard for serial channels
- A 5V DC/DC converter for power isolation
- Hot insertion is supported

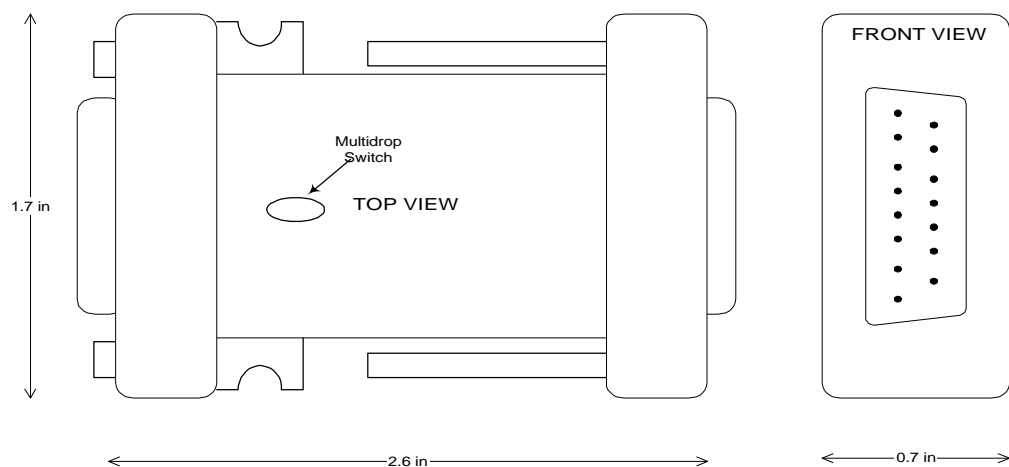

Figure G-1. RS485 Port Isolator

## Connectors

The Isolator provides two connectors, one 15 pin male D-type (PL1) and one 15 pin female D-type (PL2).

### RS-485 Connectors

|     | Pin | Pin Name | Pin Type | Description       |
|-----|-----|----------|----------|-------------------|
| PL1 | 1   | SHLD     | -        | Chassis Ground    |
|     | 2   | NC       | -        |                   |
|     | 3   | NC       | -        |                   |
|     | 4   | NC       | -        |                   |
|     | 5   | 5V       | -        | +5V power         |
|     | 6   | CTS (A') | In       | Clear to send -   |
|     | 7   | 0V       | -        | Signal Ground     |
|     | 8   | RTS (B)  | Out      | Request to send + |
|     | 9   | NC       | -        |                   |
|     | 10  | SD (A)   | Out      | Send data -       |
|     | 11  | SD (B)   | Out      | Send data +       |
|     | 12  | RD (A')  | In       | Read data -       |
|     | 13  | RD (B')  | In       | Read data +       |
|     | 14  | CTS (B') | In       | Clear to send +   |
|     | 15  | RTS (A)  | Out      | Request to send - |

|     | Pin | Pin Name | Pin Type | Description           |
|-----|-----|----------|----------|-----------------------|
| PL2 | 1   | NC       | -        |                       |
|     | 2   | NC       | -        |                       |
|     | 3   | NC       | -        |                       |
|     | 4   | NC       | -        |                       |
|     | 5   | 5V       | -        | +5V power             |
|     | 6   | RTS (A)  | Out      | Request to send -     |
|     | 7   | 0V       | -        | Signal Ground         |
|     | 8   | CTS (B') | In       | Clear to send +       |
|     | 9   | RT       | -        | Terminating Resistor* |
|     | 10  | RD (A')  | In       | Read data -           |
|     | 11  | RD (B')  | In       | Read data +           |
|     | 12  | SD (A)   | Out      | Send data -           |
|     | 13  | SD (B)   | Out      | Send data +           |
|     | 14  | RTS (B)  | Out      | Request to send +     |
|     | 15  | CTS (A') | In       | Clear to send -       |

\* Use the terminating resistor if the Port Isolator is used in port-to-port mode or at the end of a multi-drop configuration. To terminate the RD balanced line, place a jumper wire from pin 9 to pin 10.

\* A denotes – and B denotes +. A and B denote outputs and A' and B' denote inputs.

# Logic Diagram

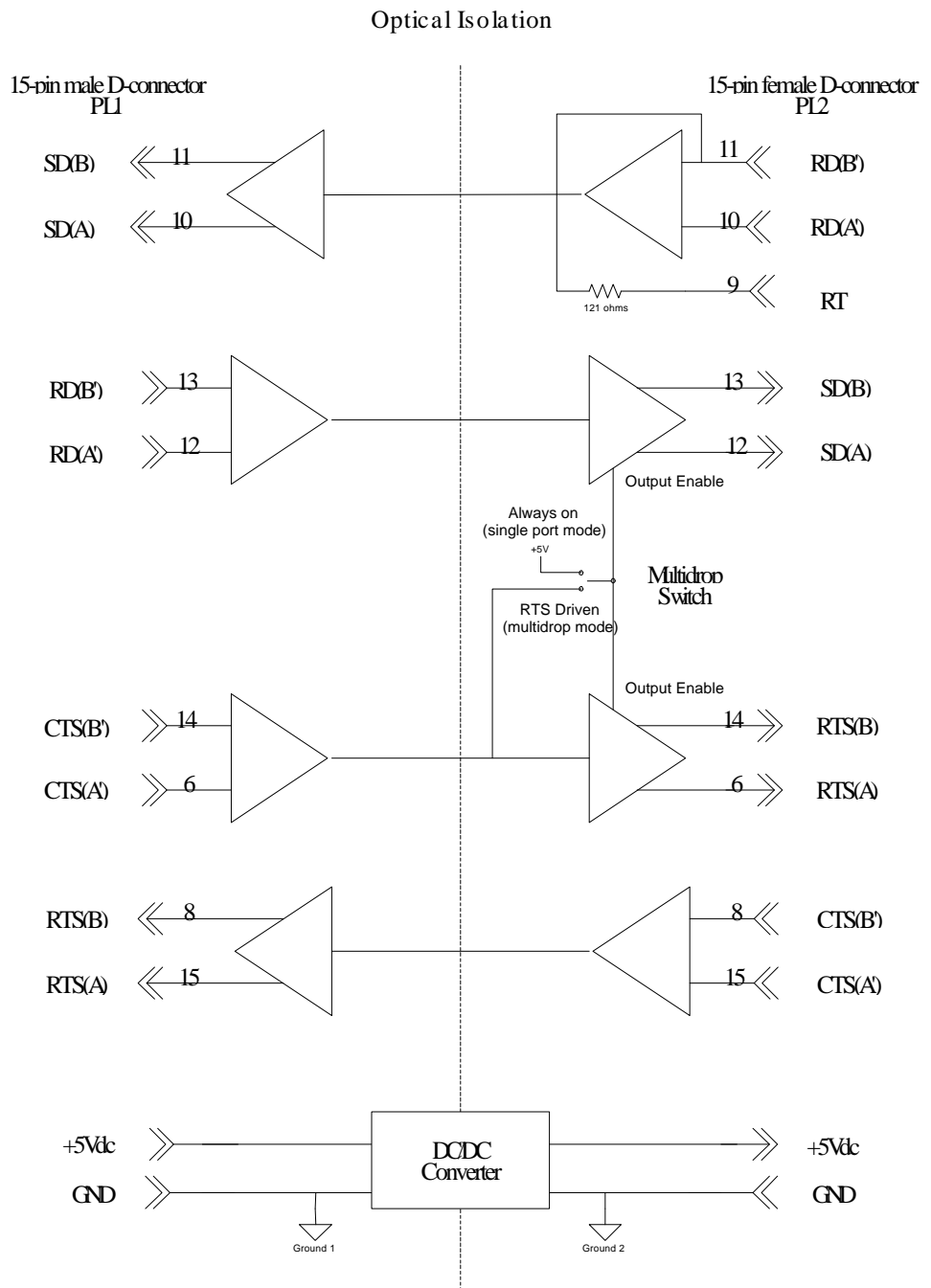

Figure G-2. IC690ACC903 Block Diagram

# Installation

The Isolator is packaged in a contoured plastic enclosure designed for either direct attachment to a serial port or through a 12" extender cable for panel mounted applications. Two M3 thumbscrews secure the device to its mating connector. The device can be easily inserted into an existing communication channel with no additional hardware. In Figure 2, the Isolator is shown connected directly to a CPU module. Alternatively, the Isolator can be mounted separately from the PLC system using the extender cable provided. For mounting separately to a panel, you will need to provide two #6-32 (4 mm) mounting screws (Figure 3).

When installing the Isolator, tighten the connector screws and panel mounting screws (if used) to the following torque values:

| Screws   | Type         | Torque                          |
|--|--------------|---------------------------------|
| Connector Thumbscrews (supplied with Isolator) | M3           | 8 in./lbs. (0.9 Newton-meter)   |
| Panel Mounting Screws (user-supplied)          | #6/32 (4 mm) | 12 in./lbs. (1.4 Newton-meters) |

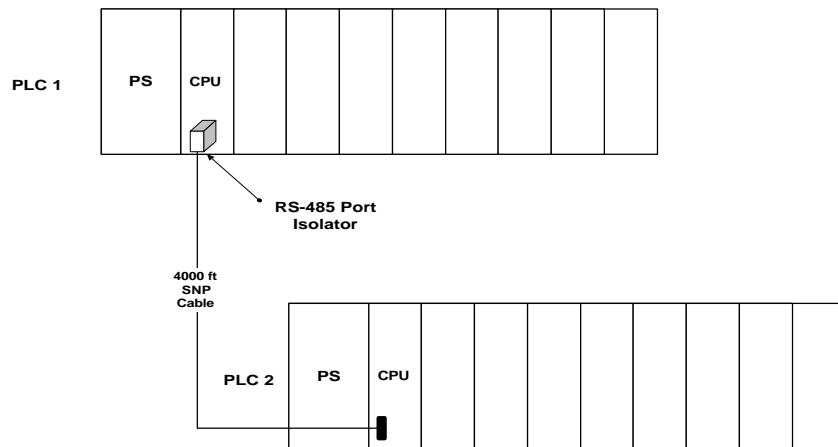

Figure G-3. RS-485 Port Isolator in PLC Network

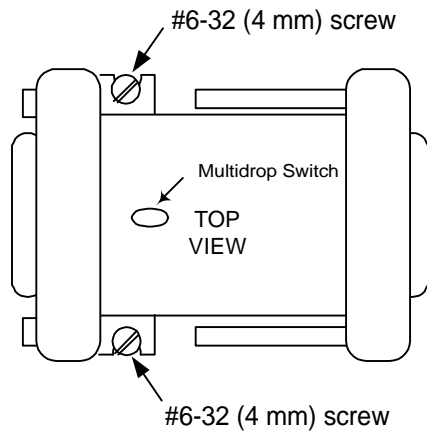

Figure G-4. Mounting Port Isolator to Panel

The RS485 Port Isolator supports both port-to-port and multi-drop configurations (Figure 4). For installation information, refer to section 3 of the Serial Communications User's Manual (GFK-0582). One configuration not covered in the User's Manual is the case where the Isolator is powered by a source other than the host port. This configuration is used to prevent an interrupt in communications if the host system requires a power cycle. It also prevents power loss to equipment using the port for power. For this, you will need to build a custom cable as shown in Figure 5.

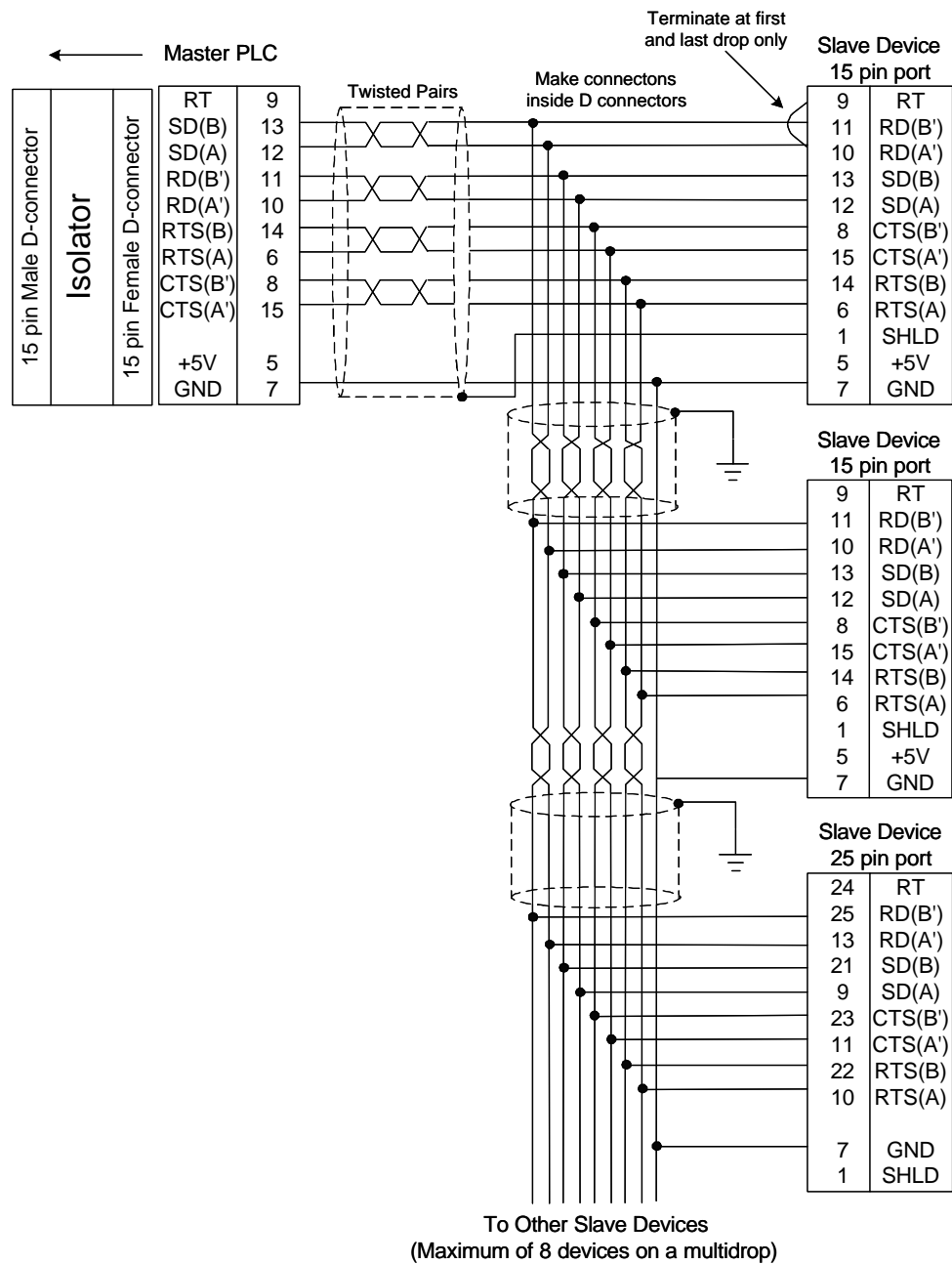

Figure G-5. Multidrop Configuration Connecting Devices with 15-Pin Ports and 25-Pin Ports

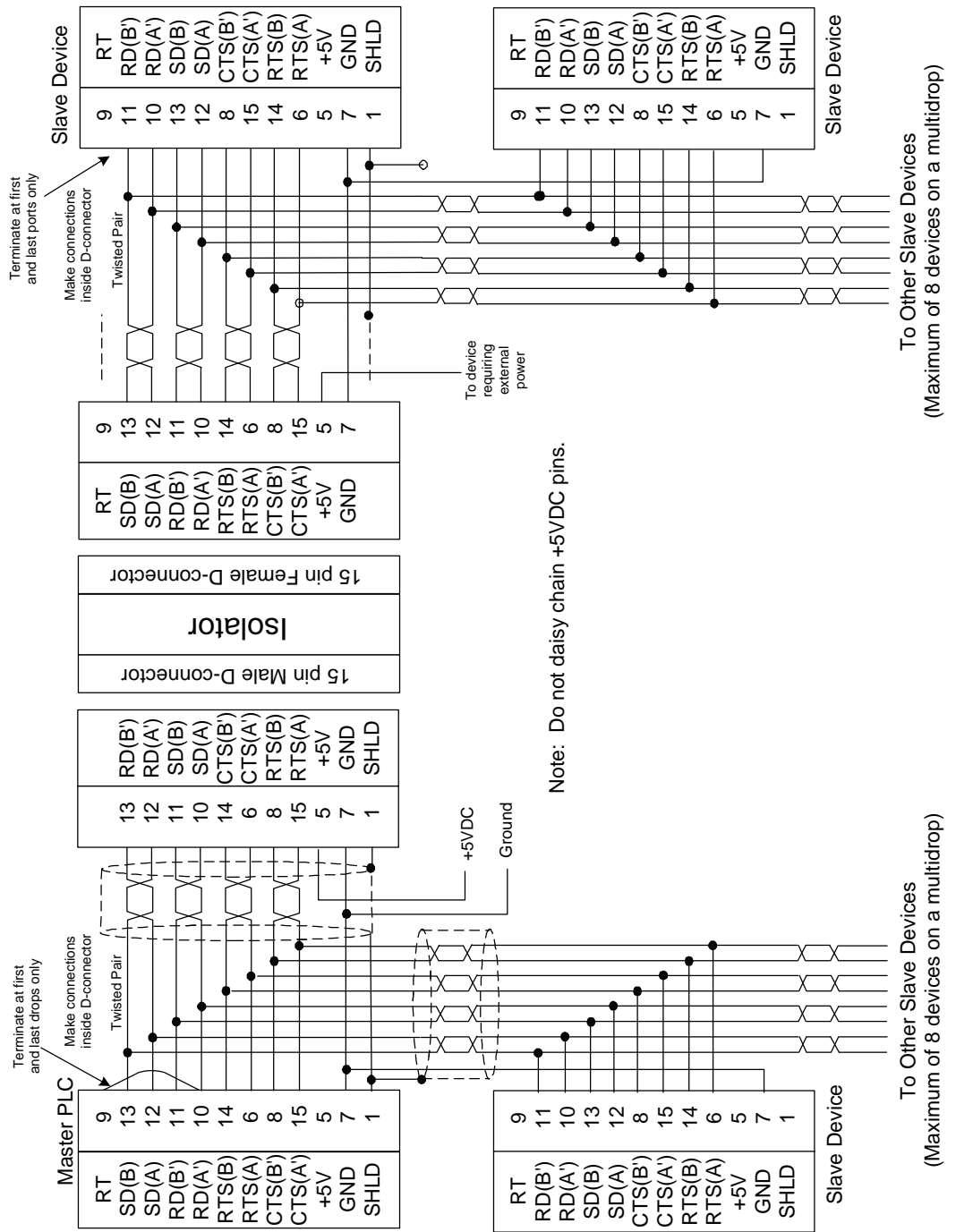

Figure G-6. Cable for Supplying External Power Through the Port Isolator

## Specifications

|                                   |   |
|-----------------------------------|---|
| <b>Mechanical</b>                 |   |
| RS-485                            | 15-pin D shell male for direct mounting to serial port on the programmable controller<br>15-pin D shell female for communication cable  |
| Installation Hardware             | Two M3 thread connector thumbscrews. Recommended torque: 8 in./lbs. (0.9 Newton-meter). These are supplied with Isolator.<br>Two user supplied #6/32 (4mm) thread panel mounting screws. Recommended torque: 12 in./lbs. (1.4 Newton-meter) |
| <b>Electrical</b>                 |   |
| Voltage Supply<br>Typical Current | +5VDC (supplied by port)<br>25 mA<br>100 mA available for external equipment  |
| Ground Isolation<br>Conformance   | 500 Volts<br>EIA-422/485 Balanced Line  |
| <b>Operating Temperature</b>      | 0° - 60°C (32° - 140° F)  |
| <b>Baud Rate</b>                  | Those supported by PLC  |

**Note: This appendix is based upon Data Sheet GFK-1663.**

## Overview

Most PLCs are mounted in an enclosure. The enclosure should be capable of properly dissipating the heat produced by all of the devices mounted inside it. This appendix describes how to calculate heat dissipation for a Series 90-30 PLC. The strategy is to calculate a heat dissipation value, in Watts, for each individual module in the PLC. Then these individual values will be added together to obtain a total heat dissipation figure for the PLC. When making your calculations, don't forget the following:

- To convert percent to a decimal, move the decimal two places to the left. For example, 40% would be expressed as 0.40, and 100% would be 1.00.
- To convert milliamps (mA) to Amperes (A or Amps), move the decimal three places to the left. For example, 10mA would convert to .010A, and 130mA would convert to 0.130A.

## Information Required

- In addition to the information in this manual, you will need GFK-0898, *Series 90-30 I/O Module Specifications Manual*.
- You will need operating current values for the discrete output devices connected to the PLC's discrete output modules. These include control relays, motor starters, solenoids, pilot lights, etc. Each device manufacturer publishes these values. If an exact value is not available for a device, you can make a close estimate by obtaining the value for a similar device from a catalog. These values are also needed for selecting Output modules during the design process in order to ensure that the modules' maximum ratings are not exceeded.

## Step 1: Basic Method to Calculate Module Dissipation

Note that this step does not apply to Power Supply Modules, which are covered in Step 2. The values needed for this calculation are found in the "Load Requirements" table in Chapter 12. We will use the basic electrical power formula in these calculations

$$\text{Power (in Watts)} = \text{Voltage (in Volts)} \times \text{Current (in Amps)}.$$

We will assume that all input power to these modules is eventually dissipated as heat. The procedure is:

- Look up the module in the “Load Requirements” table (Chapter 12) and obtain the current values for each of the three power supply voltages listed. The voltage is printed at the head of each column. All modules use the 5VDC supply, and a relatively few modules also use one or both of the two 24VDC supplies.
- For a given module, calculate the power dissipation for each column in the table that contains a current value by multiplying the current value (in Amps) times the voltage for that column. For modules using more than one voltage, add the calculated power values to arrive at the total for the module.

**Example 1:**

The “Load Requirements” table shows that the IC693CPU352 module draws:

- 910 mA from the +5VDC supply.
- No current from either of the two 12VDC supplies

To calculate power dissipation, multiply 0.910 Amps times 5 Volts. The answer is:

4.55 Watts (of heat dissipated by this module)

**Example 2:**

The “Load Requirements” table shows that the IC693MDL241 module draws:

- 80 mA from the +5VDC supply
- 125 mA from the +24VDC Isolated supply

To calculate power dissipation from the +5VDC supply:

Multiply 0.08 Amps times 5 Volts to arrive at a value of 0.40 Watts.

To calculate power dissipation from the +24VDC supply:

Multiply 0.125 Amps times 24 Volts to arrive at a value of 3.0 Watts.

Adding the two together, we find the total heat dissipated by this module is 3.4 Watts.

## Step 2: Calculation for PLC Power Supplies

A basic rule for Series 90 power supplies is that they are 66% efficient. Another way of stating this is that the power supply dissipates 1 Watt of power in the form of heat for every 2 Watts of power it delivers to the PLC. Therefore, you can calculate the total power requirement for all of the modules in the rack served by a particular power supply using the method in Step 1 above, then divide that figure by 2 to arrive at the power supply dissipation value. You cannot simply use the rating of the power supply (such as 30 Watts) for this calculation because the application may not

require the full capacity of the power supply. If you are using the +24VDC output on the power supply's terminal strip, you should calculate the power drawn, divide the value by 2, and add it to the total for the power supply. Since each Series 90-30 rack has its own power supply, each rack should be calculated on an individual basis.

### Step 3: Output Calculations for Discrete Output Modules

Discrete solid state Output modules require two calculations, one for the module's signal-level circuits, which was already done in Step 1, and one for the output circuits. (This output circuit calculation is not required for the Relay Output modules.) Since the solid state output switching devices in these modules will drop a measurable amount of voltage, their power dissipation can be calculated. Note that the power dissipated by the output circuits comes from a separate power source, so it is not included in the figure used to calculate PLC power supply dissipation in Step 2.

#### To calculate output circuit power dissipation:

- In the *Series 90-30 I/O Module Specifications Manual*, GFK-0898, find the value for the Output Voltage Drop for your particular module.
- Obtain the required current value for each device (such as a relay, pilot light, solenoid, etc.) connected to an output point on the module and estimate its percent of "on-time." To obtain the current values, check the device manufacturer's documentation or an electronics catalog. The percent of on-time can be estimated by someone familiar with how the equipment operates or will operate.
- Multiply the Output Voltage Drop times the current value times the estimated percent of on-time to arrive at average power dissipation for that output.
- Repeat for all outputs on the module. To save time, you could determine if several outputs were similar in current draw and on-time so that you would only have to make their calculation once.
- Repeat these calculations for all Discrete Output modules in the rack.

#### Discrete Output Module Example:

The *Series 90-30 PLC I/O Module Specifications Manual*, GFK-0898, lists the following for the IC693MDL340 16-Point Discrete 120VAC Output Module:

*Output Voltage Drop: 1.5 Volts maximum*

Use that value for all of the calculations for this module.

In this example, two of the Output module's output points drive solenoids that control the advance and retract travel of a hydraulic cylinder. The solenoid manufacturer's data sheet shows that each solenoid draws 1.0 Amp. The cylinder advances and retracts once every 60 seconds that the machine is cycling. It takes 6 seconds to advance and 6 seconds to retract.

Since the cylinder takes equal time to advance and retract, both solenoids are on for equal lengths of time: 6 seconds out of every 60 seconds, which is 10% of the time. Therefore, since both

solenoids have equal current draws and on-times, our single calculation can be applied to both outputs.

Use the formula *Average Power Dissipation = Voltage Drop x Current Draw (in Amps) x Percent (expressed as a decimal) of on-time*:

$$1.5 \times 1.0 \times 0.10 = 0.15 \text{ Watts per solenoid}$$

Then multiply this result by 2 since we have two identical solenoids:

$$0.15 \text{ Watts} \times 2 \text{ Solenoids} = 0.30 \text{ Watts total for the two solenoids}$$

Also in this example, the other 14 output points on this 16-point module operate pilot lights on an operator's panel. Each pilot light requires .05 Amps of current. Seven of the pilot lights are on 100% of the time and seven are on an estimated 40%.

For the 7 lights that are on 100% of the time:

$$1.5 \times .05 \times 1.00 = 0.075 \text{ Watts per light}$$

Then multiply this value by 7:

$$0.075 \text{ Watts} \times 7 \text{ lights} = 0.525 \text{ Watts total dissipation for the first 7 lights}$$

For the 7 lights that are on 40% of the time:

$$1.5 \times .05 \times 0.40 = .03 \text{ Watts per light}$$

Then multiply this value by 7:

$$.03 \text{ Watts} \times 7 \text{ lights} = 0.21 \text{ Watts total dissipation for the other 7 lights}$$

Adding up the individual calculations, we get:

$$0.30 + 0.525 + 0.21 = 1.035 \text{ Watts for the module's total output calculation}$$

## Step 4: Input Calculations for Discrete Input Modules

A Discrete Input Module requires two calculations, one for the module's signal-level circuits, which was already done in Step 1, and one for the input circuits. Note that the power dissipated by the input circuits comes from a separate power source, so are not included in the figure used to calculate PLC power supply dissipation in Step 2. We will assume that all input circuit power delivered to these modules is eventually dissipated as heat. The procedure is:

- Find the value for the Input Current in the "Specifications" table for your input module in the *Series 90-30 I/O Module Specifications Manual*, GFK-0898.

- Multiply the input voltage times the current value times the estimated percent of on-time to arrive at average power dissipation for that input.
- Repeat for all inputs on the module. To save time, you could determine if several inputs were similar in current draw and on-time so that you would only have to make their calculation once.
- Repeat these calculations for all Discrete Input modules in the rack.

**Discrete Input Module Example:**

The “Specifications” table for the IC693MDL240 16-Point Discrete 120 VAC Input Module in the *Series 90-30 PLC I/O Module Specification Manual*, GFK-0898, gives the following information:

*Input Current: 12 mA (typical) at rated voltage*

Use this value for all of the input calculations for this module.

In this example, eight of the Input Module’s points are used for switches that, for normal operation, stay on (closed) 100% of the time. These include the Emergency Stop, Over Temperature, Lube Pressure OK, and similar switches.

Use the formula *Average Power Dissipation = Input Voltage x Input Current (in Amps) x Percent (expressed as a decimal) of on-time*:

$$120 \times .012 \times 1.0 = 1.44 \text{ Watts per input}$$

Then multiply this result by 8:

$$1.44 \text{ Watts} \times 8 \text{ inputs} = 11.52 \text{ Watts total for the 8 inputs}$$

Also in this example, two input points on this 16-point module are for the Control On and Pump Start pushbuttons. Under normal conditions, these pushbuttons are only pressed once per day for about one second – just long enough to start up the control and pump. Therefore, their effect on our power calculation is negligible and we will assume a power dissipation of zero for them:

$$0.0 \text{ Watts total for 2 inputs}$$

For the remaining six inputs of our sixteen point module, it is estimated that they will be on for an average of 20% of the time. So the following calculation is made for these six inputs:

Using the formula of *Average Power Dissipation = Input Voltage x Input Current (in Amps) x Percent (expressed as a decimal) of on-time*:

$$120 \times .012 \times 0.20 = 0.288 \text{ Watts per input}$$

Then multiply this result by 6:

$$0.288 \text{ Watts} \times 6 \text{ inputs} = 1.728 \text{ Watts total for the 6 inputs}$$

Finally, adding up the individual calculations, we get:

$$11.52 + 0.0 + 1.728 = 13.248 \text{ Watts for the module's total input calculation}$$

## Step 5: Final Calculation

Once the individual power dissipations have been calculated, add them all to obtain total PLC heat dissipation. Note that the PLC baseplate, analog input modules, and analog output modules have been ignored in this procedure because their power dissipation values are negligible when compared with the total. Also, since each Series 90-30 rack has its own power supply, each rack should be calculated on an individual basis. The following table summarizes the final calculation:

| <b>Series 90-30 Rack Heat Dissipation Calculation Summary</b> |   |                      |
|---|---|----------------------|
| <b>Step</b>   | <b>Description</b>  | <b>Value (Watts)</b> |
| 1   | Calculate total of dissipation values for all modules in the rack     |                      |
| 2   | Divide value obtained in Step 1 by 2 to obtain Power Supply value     |                      |
| 3   | Calculate total of all Output modules' output dissipation values      |                      |
| 4   | Calculate total of all Input modules' input dissipation values        |                      |
| 5   | Add the above four values to obtain the total dissipation of the rack |                      |

## Other Information Related to Enclosure Sizing

The "Baseplates" chapter of this manual contains rack dimensions and minimum ventilation clearance distances required around the racks. The "Cables" chapter contains clearance dimensions for cables that mount on the front of modules.

# Appendix *Catalog Number to Publication Cross-Reference*

## *I*

[efesotomasyon.com](http://efesotomasyon.com)

---

---

### Purpose

Manuals are not shipped with many of the Series 90-30 products; they must be ordered separately. This appendix can help you identify the correct documentation to order and use. Products are arranged in this appendix by categories such as Analog I/O Modules, Baseplates, Communications Modules, etc. The category headings are listed in alphabetical order. Modules that share common documentation are grouped under a generic catalog number, such as IC693ALGxxx for the Analog I/O modules.

Note that you may not need every publication listed for a particular product. Your need for some of the publications depends on your application. For example, if you intend to use Logicmaster Programming software to configure and program your PLC, you will not need the Control, VersaPro, or Hand Held Programmer manuals. Or, if you are going to program your Programmable Coprocessor module using the C computer language, you will not need the MegaBasic language manual. For your convenience, a list of publication titles is included at the end of this data sheet.

### Abbreviations Used

- HHP stands for Hand-Held Programmer.
- LM90 stands for Logicmaster, a DOS-based programming and configuration software.
- Control stands for GE Fanuc Control, a Windows-based programming and configuration software.
- SFC stands for Sequential Function Chart.

| <b>General System Information</b> |   |
|-----------------------------------|---|
| 90-30 PLC System                  | Installation: GFK-0356<br>Installation for Conformance to Standards: GFK-1179<br>Configuration Options: <ul style="list-style-type: none"><li>• Configuration (HHP): GFK-0402</li><li>• Configuration (LM90): GFK-0466</li><li>• Configuration (Control): GFK-1295</li><li>• Configuration (VersaPro): GFK-1670</li></ul> |

## Analog I/O Modules

| Catalog Number   | Task: Publication Number (revision letters not included) |
|--|--|
| All Analog Input, Output, and Combination. Modules (IC693ALGxxx) | Installation, Configuration, Specifications: GFK-0898    |

## Baseplates

|   |   |
|---|---|
| All Series 90-30 Baseplates (IC693CHSxxx) | Installation: GFK-0356<br>Configuration Options: <ul style="list-style-type: none"> <li>• Configuration (HHP): GFK-0402</li> <li>• Configuration (LM90): GFK-0466</li> <li>• Configuration (Control): GFK-1295</li> <li>• Configuration (VersaPro): GFK-1670</li> </ul> |
|---|---|

## Communications Modules

|  |  |
|--|--|
| IC693BEM320<br>I/O Link Interface Module (slave) | Installation, Configuration, User's Guide: GFK-0631  |
| IC693BEM321<br>I/O Link Master Module            | Installation, Configuration, User's Guide: GFK-0823  |
| IC693BEM330<br>FIP Remote I/O Scanner Module     | Installation, Configuration, User's Guide: GFK-1037<br>Related Publications: <ul style="list-style-type: none"> <li>• Interfacing to Series 90-70: GFK-1038</li> <li>• Hand Held Programmer User's Manual: GFK-0402</li> <li>• FIP Bus Controller User's Manual: GFK-1213</li> </ul> |
| IC693BEM340<br>FIP Bus Controller Module         | Installation, Configuration, User's Guide: GFK-1213<br>Related Publications: <ul style="list-style-type: none"> <li>• Hand Held Programmer User's Manual: GFK-0402</li> <li>• FIP Bus Interface Unit: GFK-1175</li> <li>• FIP Remote I/O Scanner: GFK-1037</li> </ul>                |

|  |  |
|--|--|
| IC693CMM311<br>Comm. Coprocessor<br>Module | Installation, Configuration, User's Guide: GFK-0582  |
| IC693CMM321<br>Ethernet Module             | Installation, Configuration, User's Guide: GFK-1541<br>Programming Options: <ul style="list-style-type: none"> <li>• Ethernet Station Manager: GFK-1186</li> <li>• Host Communications Toolkit, C/C++: GFK-0870</li> <li>• Host Communications Drivers, MS Windows: GFK-1026</li> <li>• Host Communications Toolkit, Visual Basic: GFK-1063</li> </ul> |

**CPU Modules, CPU311-CPU341**

|   |  |
|---|--|
| Series 90-30 CPUs<br>(IC693CPU311 -<br>IC693CPU341) | Installation: GFK-0356<br>Configuration and Programming Options: <ul style="list-style-type: none"> <li>• Configuration and Programming (HHP): GFK-0402</li> <li>• Configuration (LM90): GFK-0466</li> <li>• Programming (LM90): GFK-0467</li> <li>• SFC Programming (LM90): GFK-0854</li> <li>• Configuration / Programming (VersaPro): GFK-1670</li> </ul> |
|---|--|

**CPU Modules, CPU350 - CPU364**

|                           |   |
|---------------------------|---|
| IC693CPU350<br>CPU Module | Installation: GFK-0356<br>Configuration and Programming Options: <ul style="list-style-type: none"> <li>• Configuration / Programming (HHP): GFK-0402</li> <li>• Configuration (Control): GFK-1295</li> <li>• Programming (Control): GFK-1411</li> <li>• SFC Programming (Control): GFK-1385</li> <li>• Configuration (LM90): GFK-0466</li> <li>• Programming (LM90): GFK-0467</li> <li>• SFC Programming (LM90): GFK-0854</li> <li>• Configuration / Programming (VersaPro): GFK-1670</li> </ul> |
|---------------------------|---|

|  |   |
|--|---|
| <p>IC693CPU351<br/>IC693CPU352<br/>CPU Modules</p> | <ul style="list-style-type: none"> <li>• Installation: GFK-0356</li> <li>• Serial Communications: GFK-0582</li> <li>• Configuration and Programming Options:</li> <li>• Configuration / Programming (HHP): GFK-0402</li> <li>• Configuration (Control): GFK-1295</li> <li>• Programming (Control): GFK-1411</li> <li>• SFC Programming (Control): GFK-1385</li> <li>• Configuration (LM90): GFK-0466</li> <li>• Programming (LM90): GFK-0467</li> <li>• SFC Programming (LM90): GFK-0854</li> <li>• Configuration / Programming (VersaPro): GFK-1670</li> </ul>     |
| <p>IC693CPU360<br/>CPU modules</p>                 | <p>Installation: GFK-0356</p> <p>Configuration and Programming Choices:</p> <ul style="list-style-type: none"> <li>• Configuration / Programming (HHP): GFK-0402</li> <li>• Configuration (Control): GFK-1295</li> <li>• Programming (Control): GFK-1411</li> <li>• SFC Programming (Control): GFK-1385</li> <li>• Configuration (LM90): GFK-0466</li> <li>• Programming (LM90): GFK-0467</li> <li>• SFC Programming (LM90): GFK-0854</li> <li>• Configuration / Programming (VersaPro): GFK-1670</li> </ul>  |
| <p>IC693CPU363<br/>CPU Module</p>                  | <p>Installation: GFK-0356P or later</p> <p>Configuration and Programming Options:</p> <ul style="list-style-type: none"> <li>• Configuration and Programming (HHP): GFK-0402</li> <li>• Configuration (Control): GFK-1295</li> <li>• Programming (Control): GFK-1411</li> <li>• SFC Programming (Control): GFK-1385</li> <li>• Configuration (LM90): GFK-0466</li> <li>• Programming (LM90): GFK-0467</li> <li>• SFC Programming (LM90): GFK-0854</li> <li>• Configuration / Programming (VersaPro): GFK-1670</li> <li>• Serial Communications: GFK-0582</li> </ul> |

|                           |   |
|---------------------------|---|
| IC693CPU364<br>CPU Module | Installation, Configuration, User's Guide: GFK-1541<br>Specifications: GFK-0356P or later<br>Configuration and Programming Options: <ul style="list-style-type: none"><li>• Configuration (Control): GFK-1295</li><li>• Programming (Control): GFK-1411</li><li>• SFC Programming (Control): GFK-1385</li><li>• Configuration (LM90): GFK-0466</li><li>• Programming (LM90): GFK-0467</li><li>• SFC Programming (LM90): GFK-0854</li><li>• Configuration / Programming (VersaPro): GFK-1670</li><li>• Ethernet Station Manager: GFK-1186</li><li>• Host Communications Toolkit, C/C++: GFK-0870</li><li>• Host Communications Drivers, MS Windows: GFK-1026</li><li>• Host Communications Toolkit, Visual Basic: GFK-1063</li></ul> |
|---------------------------|---|

**Digital Valve Driver Module**

|             |  |
|-------------|--|
| IC693DVM300 | Installation and Specifications: GFK-0356P or later<br>Configuration Options: <ul style="list-style-type: none"><li>• This module does not connect to PLC backplane; therefore, it mounts in an unconfigured slot.</li></ul> |
|-------------|--|

**Discrete I/O Modules**

|   |   |
|---|---|
| All Discrete Input, Output, and Combination Modules (IC693MDLxxx) | Installation and Specifications: GFK-0898<br>Configuration Options: <ul style="list-style-type: none"><li>• Configuration (HHP): GFK-0402</li><li>• Configuration (LM90): GFK-0466</li><li>• Configuration (Control): GFK-1295</li><li>• Configuration (VersaPro): GFK-1670</li></ul> |
|---|---|

## Genius Modules

|   |   |
|---|---|
| IC693BEM331<br>Genius Bus Controller            | Installation, Configuration, User Guide: GFK-1034<br>Related Publication:<br><ul style="list-style-type: none"> <li>• Genius I/O System User's Manual: GEK-90486-1</li> <li>• Genius Blocks User's Manual: GEK-90486-2</li> </ul> |
| IC693CMM301<br>Genius Comm. Module              | Installation, Configuration, User Guide: GFK-0412<br>Related Publication:<br>Genius I/O System User's Manual: GEK-90486-1   |
| IC693CMM302<br>Genius Comm. Module + (Enhanced) | Installation, Configuration, User Guide: GFK-0695<br>Related Publication:<br>Genius I/O System User's Manual: GEK-90486-1   |

## Motion Modules

|   |  |
|---|--|
| IC693APU300<br>High Speed Counter                         | Installation, Configuration, User Guide: GFK-0293  |
| IC693APU301<br>IC693APU302<br>Axis Positioning Modules    | Installation, Configuration, User's Guide:<br><ul style="list-style-type: none"> <li>• Standard Mode: GFK-0840</li> <li>• Follower Mode: GFK-0781</li> <li>• Motion Programming: GFK-0664</li> </ul> |
| IC693DSM302<br>Digital Servo Module                       | Installation, Configuration, User's Guide (standard and follower modes): GFK-1464<br>Motion Programming: GFK-0664  |
| IC693DSM314<br>Digital Servo Module (Available late 1999) | Installation, Configuration, Local Logic, Motion Programming User's Guide (standard and follower modes): (Manual will not be available until late 1999) GFK-1742                                     |

## Other Option Modules

|   |  |
|---|--|
| <p>IC693ADC311<br/>Alphanumeric Coprocessor Module</p>                                    | <p>Installation, Configuration, User's Guide: GFK-0499</p> <p>Programming Options:</p> <ul style="list-style-type: none"> <li>• Programming, PCOP Development Software: GFK-0487</li> <li>• ADS Display System Reference Manual: GFK-0641</li> </ul>   |
| <p>IC693TCM302<br/>Temperature Control Module</p>   | <p>Installation, Configuration, User's Guide: GFK-1466</p>   |
| <p>IC693APU305<br/>I/O Processor Module</p>   | <p>Installation, Configuration, User's Guide: GFK-1028</p>   |
| <p>IC693PCM300<br/>IC693PCM301<br/>IC693PCM311<br/>Programmable Coprocessor Modules</p>   | <p>Installation, Configuration, User's Guide: GFK-0255</p> <p>Programming Options:</p> <ul style="list-style-type: none"> <li>• Programming, PCOP Development Software: GFK-0487</li> <li>• Programming, MegaBasic: GFK-0256</li> <li>• Programming, C Language: GFK-0771</li> <li>• PCM C Function Library Reference: GFK-0772</li> <li>• PCM Quick Reference Guide: GFK-0260</li> <li>• PCOP Quick Reference Guide: GFK-0657</li> <li>• TERMF Quick Reference Guide: GFK-0655</li> </ul> |
| <p>IC693PTM100<br/>Power Transducer Module (PTM)<br/>(Not available until late 1999.)</p> | <p>Installation, configuration, user's guide: GFK-1734<br/>(Not available until late 1999.)</p>  |

## Power Supply Modules

|  |  |
|--|--|
| All Series 90-30<br>Power Supply<br>Modules<br>(IC693PWRxxx) | Installation: GFK-0356 (Version P required for preliminary information on IC693PWR332.)<br>Configuration Options: <ul style="list-style-type: none"> <li>• Configuration (HHP): GFK-0402</li> <li>• Configuration (LM90): GFK-0466</li> <li>• Configuration (Control): GFK-1295</li> <li>• Configuration (VersaPro): GFK-1670</li> </ul> |
|--|--|

## Programming Device

|  |   |
|--|---|
| IC693PRG300<br>Hand-Held<br>Programmer | User's Manual (using the HHP for configuration and programming): GFK-0402 |
|--|---|

## State Logic Products

|   |   |
|---|---|
| IC693CSE311<br>IC693CSE313<br>IC693CSE323<br>IC693CSE331<br>IC693CSE340<br>State Logic CPUs | Installation, Configuration, User's Guide: GFK-1056<br>Programming Options: <ul style="list-style-type: none"> <li>• ECLiPS English Control Language: GFK-0732</li> <li>• OnTOP User's Guide: GFK-0747</li> <li>• OnTOP Troubleshooting Manual: GFK-0750</li> </ul> |
| AD693SLP300<br>State Logic Processor<br>(SLP) Module  | Installation, Configuration, User's Guide: GFK-0726<br>Software Options: <ul style="list-style-type: none"> <li>• ECLiPS English Control Language: GFK-0732</li> <li>• OnTOP Troubleshooting Manual: GFK-0750</li> </ul>  |
| AD693CMM301<br>State Logic Serial<br>Communications<br>(SCM) Module                         | Installation, Configuration, User's Information Data Sheet:<br>GFK-1529<br>See also: GFK-1056   |

---

## Understanding Publication Revision Letters

When a GE Fanuc publication is revised, a letter is placed at the end of the publication number. For example, in the publication number GFK-0356N, the revision letter N at the end indicates the version of the manual. Manuals are revised when there are changes or additions to the products or product lines covered in the manual. Since this is a continual process, we decided that, except in a few special cases, we would not include revision letters in this appendix in order to prevent confusion. Therefore, when ordering these publications, ask for the latest version.

Note: Under normal circumstances, if a publication number does not have an ending letter (suffix), such as GFK-1581, it is an indication that the publication has never been revised.

## Other Sources of Information

- **GE Fanuc InfoLink PLC CD.** This CD contains a collection of GE Fanuc PLC manuals for Series 90-30, Series 90-70, Genius, VersaMax, etc. There is also an InfoLink available for GE Fanuc CNC products. Be sure to specify which one you need when ordering from your PLC distributor.
- **GE Fanuc web site.** This web site, at <http://www.gefanuc.com>, contains not only an on-line version of the InfoLink CD, but also recently revised publications, product revision histories, the GE Fanuc Automation Solutions Catalog, and Third-Party product information.

Note: The information in this appendix is based upon Data Sheet GFK-1661.

| <b>Publication No.</b> | <b>Titles of Series 90-30 Publications Cited in this Appendix</b>                 |
|------------------------|---|
| GFK-0255               | Series 90 Programmable Coprocessor Module and Support Software User's Manual      |
| GFK-0256               | MegaBasic Language Reference and Programmer's Guide Reference Manual              |
| GFK-0260               | Programmable Coprocessor Module Quick Reference Guide                             |
| GFK-0293               | Series 90-30 PLC High Speed Counter User's Manual                                 |
| GFK-0356               | Series 90-30 PLC Installation Manual  |
| GFK-0402               | Hand-Held Programmer for Series 90-30/20/Micro PLC User's Manual                  |
| GFK-0412               | Series 90-30 Genius Communications Module User's Manual                           |
| GFK-0466               | Logicmaster 90, Series 90-30/20/Micro Programming Software User's Manual          |
| GFK-0467               | Series 90-30/20/Micro PLC Reference Manual  |
| GFK-0487               | Series 90 PCM Development Software (PCOP) User's Manual                           |
| GFK-0499               | CIMPLICITY 90-ADS Alphanumeric Display System User's Manual                       |
| GFK-0582               | Series 90 PLC Serial Communications Driver User's Manual                          |
| GFK-0631               | Series 90-30 I/O Link Slave Interface User's Manual                               |
| GFK-0641               | CIMPLICITY 90-ADS Alphanumeric Display System Reference Manual                    |
| GFK-0655               | Series 90 PCM Support Software (TERMF) Quick Reference Guide                      |
| GFK-0657               | Series 90 PCM Development Software (PCOP) Quick Reference Guide                   |
| GFK-0664               | Series 90-30 Axis Positioning Module Programmer's Manual                          |
| GFK-0695               | Series 90-30 Enhanced Genius Communications Module User's Manual                  |
| GFK-0726               | State Logic Processor For Series 90-30 PLC User's Guide                           |
| GFK-0732               | ECLiPS English Control Language Prog. System for Series 90-30 PLC User's Guide    |
| GFK-0750               | OnTOP for Series 90-30 Online Troubleshooting and Operator Prog. User's Manual    |
| GFK-0771               | C Programmer's Toolkit for Series 90 PCMs User's Manual                           |
| GFK-0772               | PCM C Function Library Reference Manual   |
| GFK-0781               | Motion Mate APM for Series 90-30 PLC Follower Mode User's Manual                  |
| GFK-0823               | Series 90-30 I/O Link Master Module User's Guide                                  |
| GFK-0840               | Power Mate APM for Series 90-30 PLC Standard Mode User's Manual                   |
| GFK-0854               | Series 90 Sequential Function Chart Programming Language User's Manual            |
| GFK-0870               | Host Communications Toolkit for C/C++ Applications User's Manual                  |
| GFK-0898               | Series 90-30 PLC I/O Module Specifications Manual                                 |
| GFK-1026               | Host Drivers & Comm. Config. Software for Windows Environments User's Manual      |
| GDK-1028               | Series 90-30 I/O Processor Module User's Manual                                   |
| GFK-1034               | Series 90-30 Genius Bus Controller User's Manual                                  |
| GFK-1037               | Series 90-30 FIP Remote I/O Scanner User's Manual                                 |
| GFK-1038               | Series 90-70 FIP Bus Controller's User's Manual                                   |
| GFK-1056               | Series 90-30 State Logic Control System User's Manual                             |
| GFK-1063               | Host Communications Toolkit for Visual Basic Applications User's Manual           |
| GFK-1175               | Field Control Distributed I/O & Control Sys. FIP Bus Interface Unit User's Manual |
| GFK-1179               | Installation Requirements for Conformance to Standards                            |
| GFK-1186               | TCP/IP Ethernet Communications for the Series 90 PLC Station Manager Manual       |
| GFK-1213               | Series 90-30 FIP Bus Controller User's Manual                                     |
| GFK-1295               | Using GE Fanuc Control  |
| GFK-1385               | GE Fanuc Control: Using the Sequential Function Chart Editor                      |
| GFK-1411               | Series 90-30 System Manual  |
| GFK-1464               | Motion Mate DSM 302 for Series 90-30 PLCs User's Manual                           |
| GFK-1466               | Temperature Control Module for the Series 90-30 PLC User's Manual                 |
| GFK-1541               | TCP/IP Ethernet Communications for the Series 90 PLC User's Manual                |
| GFK-1670               | VersaPro User's Guide   |
| GEK-90486-1            | Genius I/O System and Communications User's Manual                                |
| GEK-90486-2            | Genius I/O Discrete and Analog Blocks User's Manual                               |

# Appendix J

## Terminal Block Quick Connect Components

[efesotomasyon.com](http://efesotomasyon.com)

This appendix describes the optional terminal block components for Series 90-30 discrete I/O modules. This system is referred to as the Terminal Block Quick Connect (TBQC) system. The advantage of this system, is that it allows the listed discrete I/O modules to be quickly connected to TBQC terminal blocks. In this system, the TBQC terminal block (shown below) is snapped onto a standard DIN-rail. Then, a factory-made cable is connected between the terminal block's connector and the I/O module's connector. An I/O module that has a terminal board instead of a connector is converted into a connector type using an adapter faceplate.

The TBQC system is not recommended for use with Analog modules because it does not meet the shielding recommendations for Analog module connections. (See the *Series 90-30 PLC I/O Module Specifications Manual*, GFK-0898, for Analog module wiring information.)

This appendix contains two sections, one for discrete 16-point I/O modules and one for discrete 32-point I/O modules.

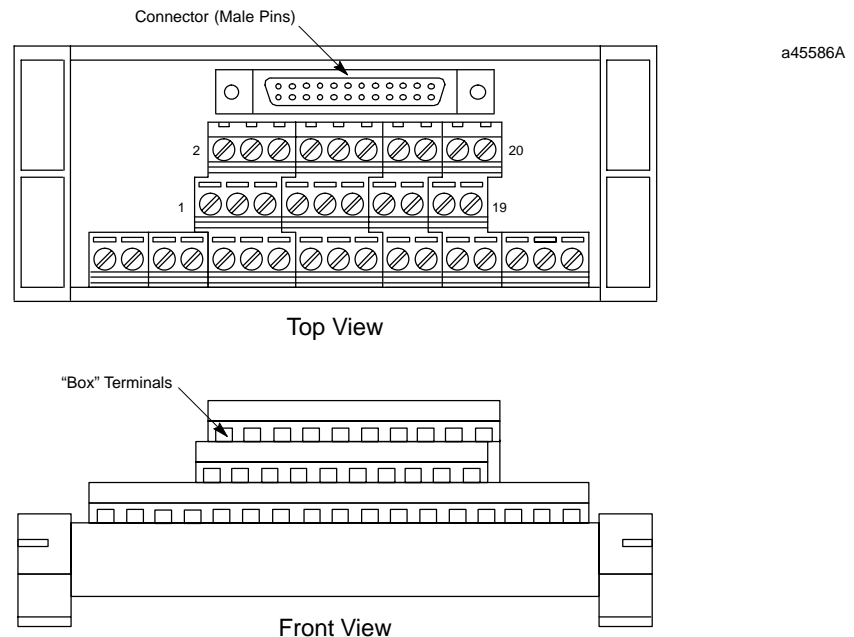

Figure J-1. Typical TBQC Terminal Block

## Terminal Block Quick Connect Components for 16-Point Modules

Installing a 16 point module typically takes 2 1/2 hours to wire from a PLC to a terminal blocks or strip. With the TBQC, you simply snap the terminal block onto a DIN rail, remove the I/O module's terminal assembly, snap in the I/O faceplate, and connect the cable. This reduces wiring time to about two minutes, thereby reducing wiring costs and errors. Complete assemblies consist of a terminal block, an I/O Face Plate, and a cable.

### Terminal Blocks

Terminal blocks have three rows of terminals, arranged in three levels, as shown in Figure J-1. These terminal blocks feature an easy to use captive-screw, "rising cage" type connection system. Catalog numbers for the terminal blocks and the modules they can be used with are listed below.

Table J-1. TBQC Terminal Block Selection Table

| Catalog Number     | Use With These Modules                    | Module Description   |
|--------------------|---|--|
| <b>IC693ACC329</b> | IC693MDL240<br>IC693MDL645<br>IC693MDL646 | Input, 120 VAC – 16 points<br>Input, 24 VDC Pos./Neg Logic– 16 points<br>Input, 24 VDC Pos./Neg.Logic,FAST – 16 points |
| <b>IC693ACC330</b> | IC693MDL740<br>IC693MDL742                | Output, 12/24VDC Pos Logic, 0.5A – 16 points<br>Output, 12/24VDC Pos Logic ESCP, 1A– 16 points                         |
| <b>IC693ACC331</b> | IC693MDL741                               | Output, 12/24 VDC Neg Logic, 0.5A– 16 points   |
| <b>IC693ACC332</b> | IC693MDL940                               | Output, Relay, N.O. – 16 points  |
| <b>IC693ACC333</b> | IC693MDL340                               | Output, 120 VAC, 0.5A – 16 points  |

1 This Terminal Block may be used with most I/O modules that have up to 16 I/O points (can not be used with 32 point modules). Jumpers may have to be added; for details of required wiring connections, refer to module specifications in GFK-0898.

### Cable Current Rating

Each conductor in these 24-conductor cables has a current rating of 1.2 Amps. If using these cables with a 16-point Output module with a higher output current rating, you must use the lower value of 1.2 Amps for the maximum load current rating . If you have field devices that require more than 1.2 Amps, do not use a TBQC assembly – use the standard Terminal Board that comes with the module instead.

## Cable Selection and Cross-Reference

Three cables are available for connecting between the module's faceplate connector and the terminal block. The only difference in these cables is their length. These cables have right-angle connectors on the module end to minimize the space required in front of the modules. These three cables replace three obsolete cables that had straight connectors. Use the following table to select the correct cable.

| Cable Catalog Number | Description  | Replaces Obsolete Cable Number |
|----------------------|--|--------------------------------|
| IC693CBL330          | CBL Assembly, 24-pin, 90 Deg, Right Side, 1.0 Meter length | IC693CBL321                    |
| IC693CBL332          | CBL Assembly, 24-pin, 90 Deg, Right Side, 2.0 Meter length | IC693CBL322                    |
| IC693CBL334          | CBL Assembly, 24-pin, 90 Deg, Right Side, 0.5 Meter length | IC693CBL323                    |

## I/O Face Plate for 16-Point Modules

The I/O Face Plate (catalog number **IC693ACC334**) has a 24-pin connector, which provides the connection to the applicable terminal block through a 0.5, 1, or 2 meter cable. This face plate replaces the standard terminal board on the listed modules.

## I/O Face Plate Installation

### Step 1: Install terminal block assembly on DIN rail

Place the terminal block over the desired location on the DIN rail and snap into place.

### Step 2: Remove 20-pin terminal assembly from module

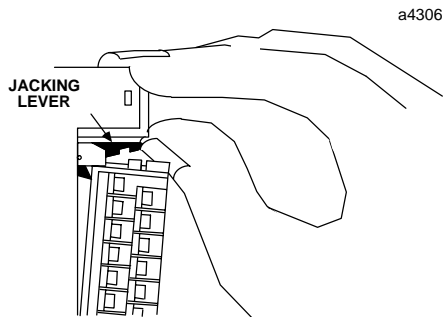

- 1 Open the plastic terminal board cover.
- 2 Push up on the jacking lever to release the terminal block.

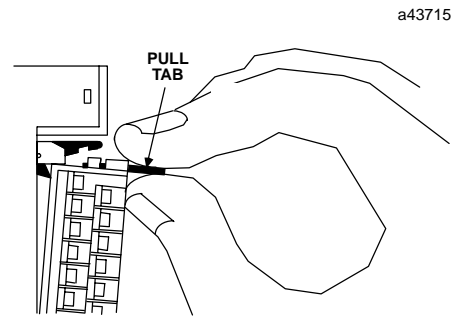

- 3 Grasp pull-tab towards you until contacts have separated from module housing and hook has disengaged for full removal.

### Step 3: Snap I/O Face Plate assembly on module

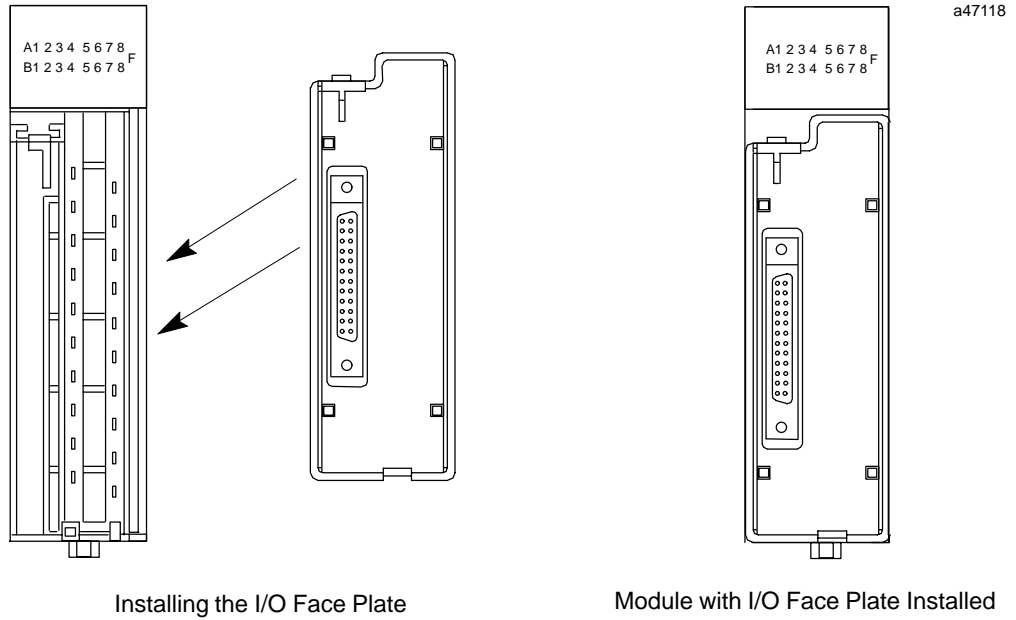

Installing the I/O Face Plate

Module with I/O Face Plate Installed

### Step 4: Connect cable to connector on terminal block

Finally, connect the selected length cable from the connector on the I/O Face Plate to the connector on the interposing terminal block.

## Module Wiring Information

Refer to GFK-0898, *Series 90-30 PLC I/O Module Specifications Manual* for wiring connections for each module.

## Cable Information

Data sheets for the cables are found in the “Cables” chapter of this manual.

## Connector Pin Orientation and Connection to Module Terminal

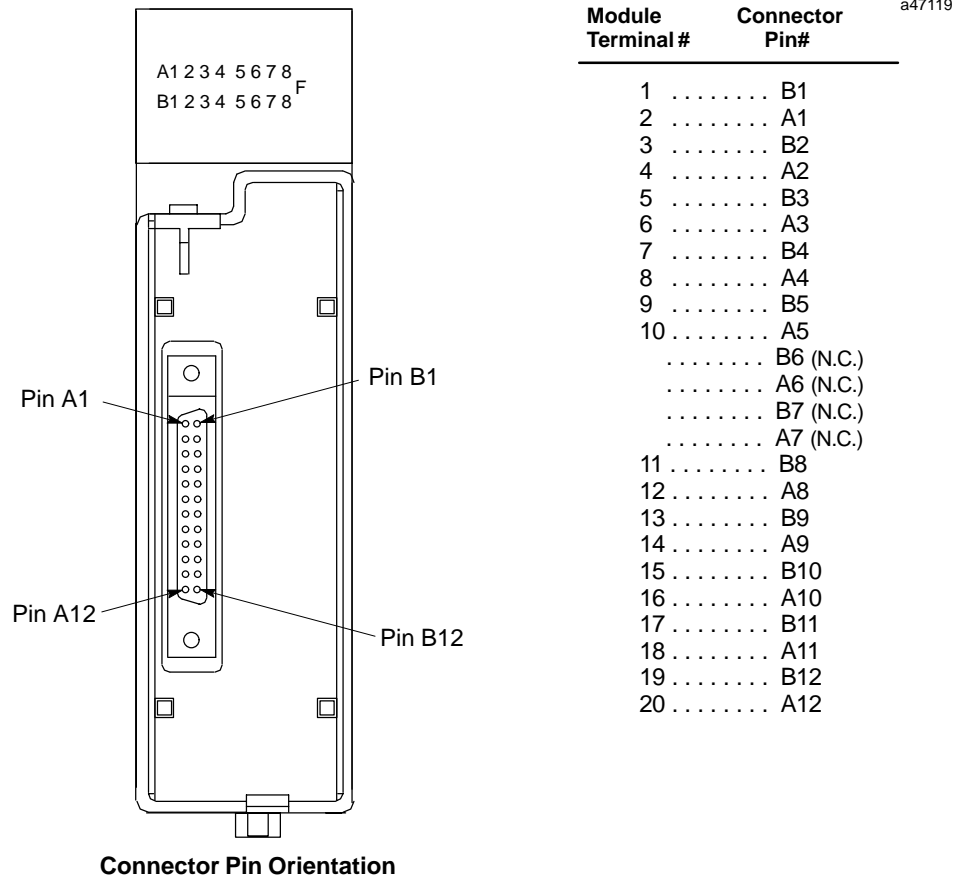

Figure J-2. TBQC Faceplate

### Terminal Block Information

Terminal block data sheets are found on the next several pages.

## IC693ACC329 TBQC Terminal Block

Use with the following 16-point I/O modules:

IC693MDL240

IC693MDL645

IC693MDL646

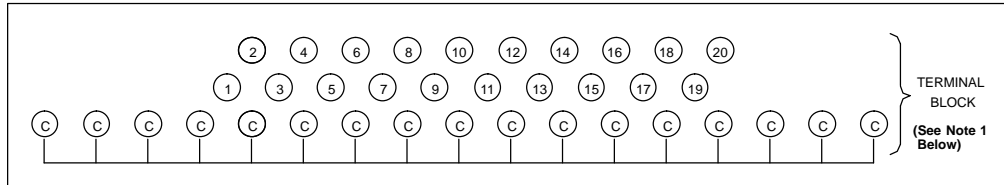
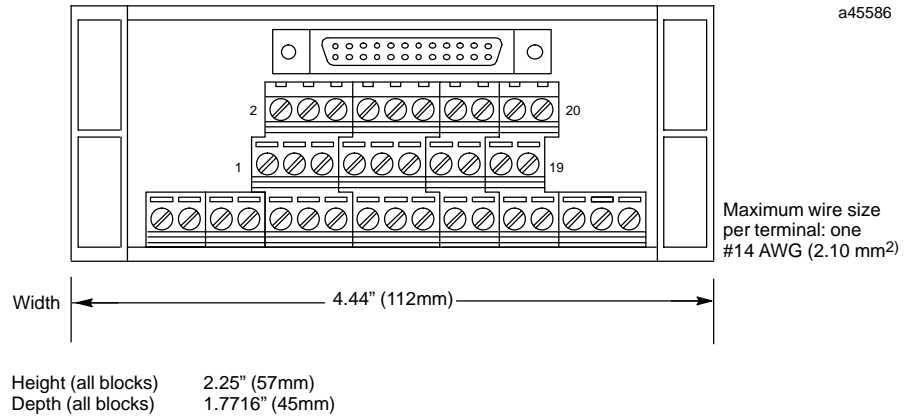

Figure J-3. IC693ACC329 TBQC Terminal Block

### Note

The common row terminals (labeled with the letter C) are provided for wiring convenience. Their use is optional. They are electrically isolated from the numbered terminals. You may use them as is, or jumper them to a numbered terminal. Refer to GFK-0898, *Series 90-30 PLC I/O Module Specifications Manual* for wiring diagrams of the modules.

### Mounting

These terminal blocks are mounted on a standard, user-supplied 35 mm DIN-rail.

## IC693ACC330 TBQC Terminal Block

Use with the following 16-point I/O modules:

IC693MDL740

IC693MDL742

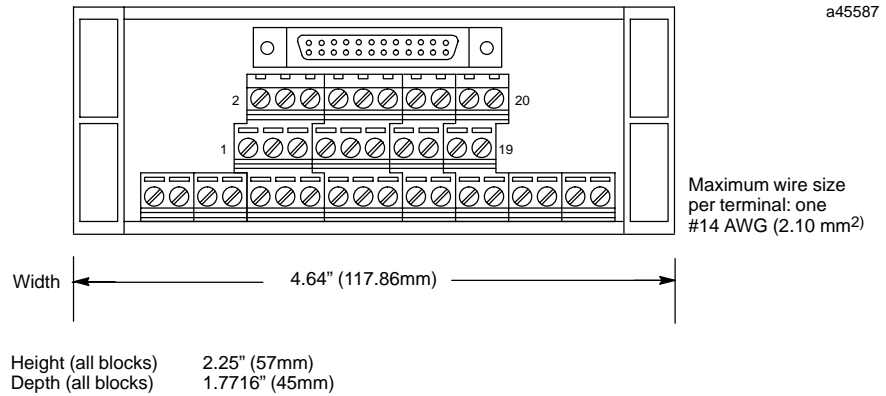

Figure J-4. IC693ACC330 TBQC Terminal Block

### Note

Refer to GFK-0898, *Series 90-30 PLC I/O Module Specifications Manual* for required wiring connections.

### Mounting

These terminal blocks are mounted on a standard, user-supplied 35 mm DIN-rail.

## IC693ACC331 TBQC Terminal Block

Use with the following 16-point I/O module:  
**IC693MDL741**

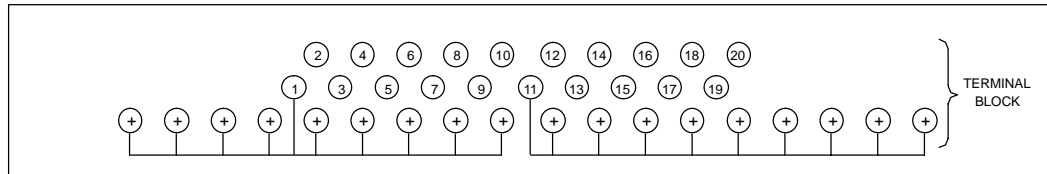
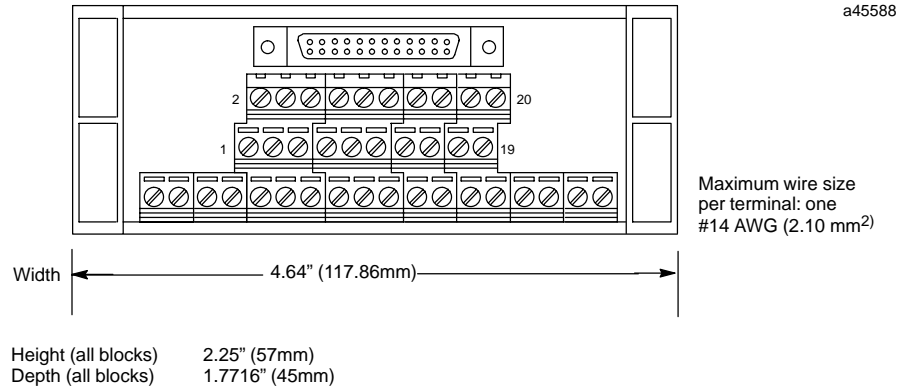

Figure J-5. IC693ACC331 TBQC Terminal Block

### Note

Refer to GFK-0898, *Series 90-30 PLC I/O Module Specifications Manual* for required wiring connections.

### Mounting

These terminal blocks are mounted on a standard, user-supplied 35 mm DIN-rail.

## IC693ACC332 TBQC Terminal Block

Use with the following 16-point I/O module:  
**IC693MDL940**

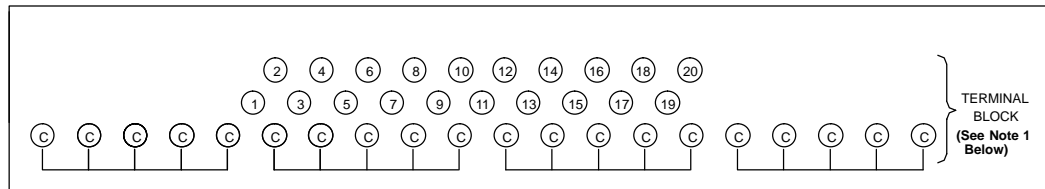
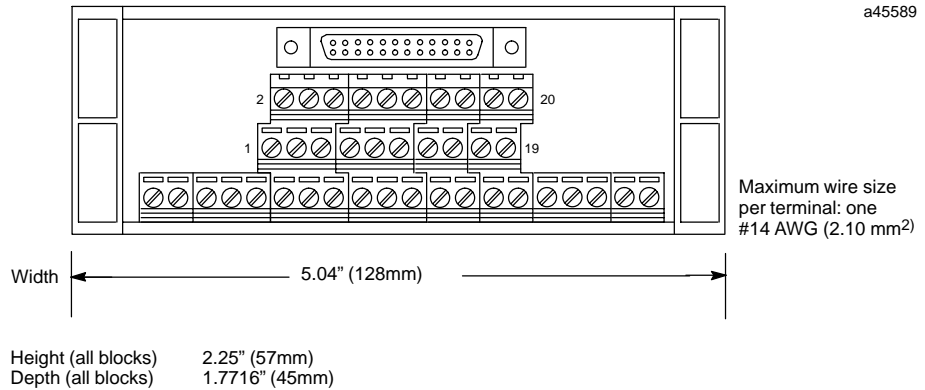

**Figure J-6. IC693ACC332 TBQC Terminal Block**

### Note

The common row terminals (labeled with the letter C) are provided for wiring convenience. Their use is optional. They are electrically isolated from the numbered terminals. You may use them as is, or jumper them to a numbered terminal. Refer to GFK-0898, *Series 90-30 PLC I/O Module Specifications Manual* for wiring diagrams of the modules.

### Mounting

These terminal blocks are mounted on a standard, user-supplied 35 mm DIN-rail.

## IC693ACC333 TBQC Terminal Block

Use with the following 16-point I/O module:  
**IC693MDL340**

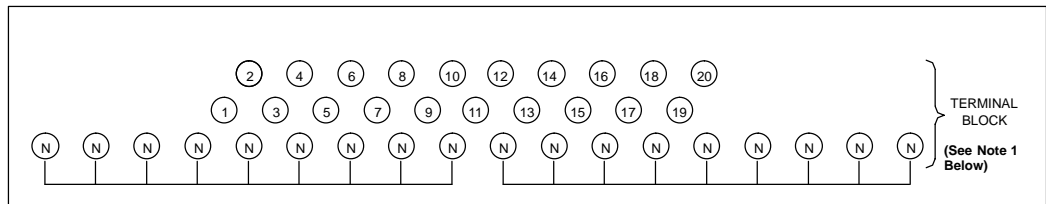
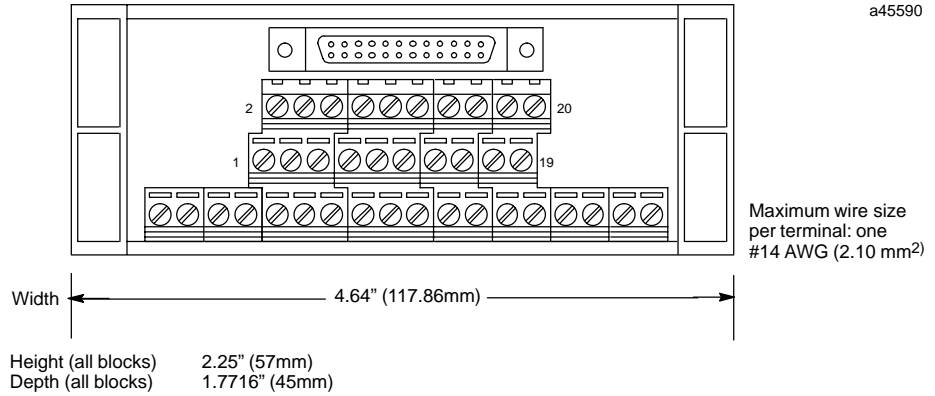

**Figure J-7. IC693ACC333 TBQC Terminal Block**

### Note

The neutral row terminals (labeled with the letter N) are provided for wiring convenience. Their use is optional. They are electrically isolated from the numbered terminals. You may use them as is, or jumper them to a numbered terminal. Refer to GFK-0898, *Series 90-30 PLC I/O Module Specifications Manual* for wiring diagrams of the modules.

### Mounting

These terminal blocks are mounted on a standard, user-supplied 35 mm DIN-rail.

## Terminal Block Quick Connect Components for 32-Point Modules

The 32-point modules do not require a new faceplate since they are equipped with a dual-connector faceplate as a standard feature. Since each module has two 24-pin connectors, they each require two cables and two terminal blocks. Also, since the modules' two connectors are oriented differently (see example in figure below), the two cables are different. One is called a "right side" cable and the other, a "left side" cable.

Note: These terminal blocks will not work with the 32-point I/O modules that have 50-pin connectors.

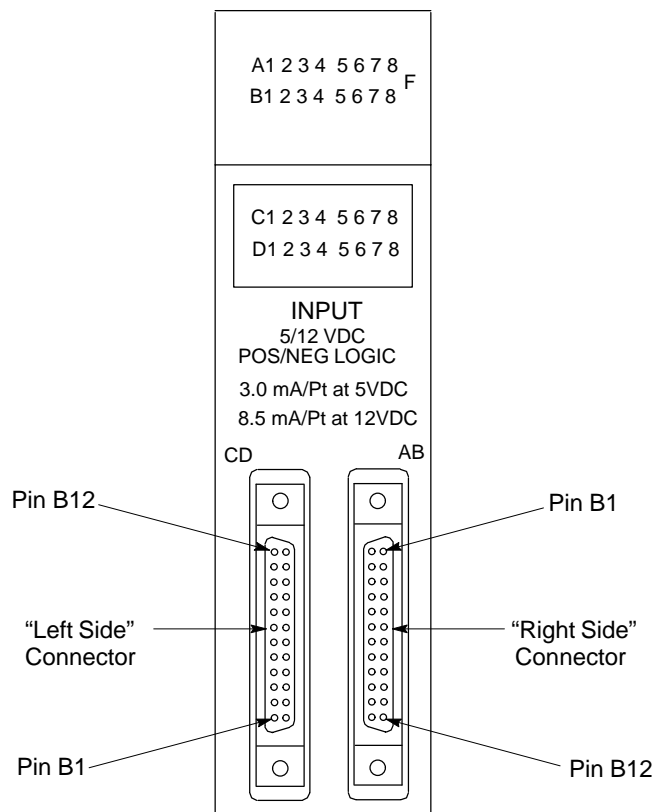

Figure J-8. IC693MDL654 32-Point Module

### Terminal Block

Terminal blocks have three rows of terminals, arranged in three levels, as shown in Figure J-1. The terminals feature an easy to use captive-screw, "rising cage" type connection system. Catalog numbers for the terminal block and the modules it can be used with are listed below.

| Catalog Number | Use With These Modules                                   | Module Description   |
|----------------|--|--|
| IC693ACC337    | IC693MDL654<br>IC693MDL655<br>IC693MDL752<br>IC693MDL753 | Input, 5/12 VDC (TTL) Pos/Neg Logic - 32 points<br>Input, 24 VDC Pos/Neg Logic - 32 points<br>Output, 5/24 VDC Neg Logic - 32 points<br>Output, 12/24VDC Pos Logic, 0.5A - 32 points |

## Cable Selection and Cross-Reference

Six cables are available for connecting between the modules' faceplate connectors and the terminal blocks. These cables have right-angle connectors on the module end to minimize the space required in front of the modules. These six cables replace three obsolete cables that had straight connectors. Since the modules' two connectors are oriented differently (see previous figure), a right-side and left-side cable is required. Use the following table to select the correct cables. The table also lists cable kits that consist of a pair of same length, right side and left side cables.

## Cable Current Rating

Each conductor in these 24-conductor cables has a current rating of 1.2 Amps, which is more than adequate to handle the current requirement of any of the 32-point I/O modules listed in the previous table.

| <b>Cable Catalog Number</b> | <b>Cable Description and Length</b>  | <b>Replaces Obsolete Cable Number</b> |
|-----------------------------|--|---------------------------------------|
| IC693CBL329                 | Dual 24-pin, 90 deg. connectors, Left Side<br>Cable length = 1.0 Meter                   | IC693CBL321                           |
| IC693CBL330                 | Dual 24-pin, 90 deg. connectors, Right Side<br>Cable length = 1.0 Meter                  | IC693CBL321                           |
| IC693CBL331                 | Dual 24-pin, 90 deg. connectors, Left Side<br>Cable length = 2.0 Meters                  | IC693CBL322                           |
| IC693CBL332                 | Dual 24-pin, 90 deg. connectors, Right Side<br>Cable length = 2.0 Meters                 | IC693CBL322                           |
| IC693CBL333                 | Dual 24-pin, 90 deg. connectors, Left Side<br>Cable length = 0.5 Meter                   | IC693CBL323                           |
| IC693CBL334                 | Dual 24-pin, 90 deg. connectors, Right Side<br>Cable length = 0.5 Meter                  | IC693CBL323                           |
| <b>Cable Kits</b>           |  |                                       |
| IC693CBK002                 | Cable Kit. Includes both the IC693CBL329 (left side) and IC693CBL330 (right side) cables |                                       |
| IC693CBK003                 | Cable Kit. Includes both the IC693CBL331 (left side) and IC693CBL332 (right side) cables |                                       |
| IC693CBK004                 | Cable Kit. Includes both the IC693CBL333 (left side) and IC693CBL334 (right side) cables |                                       |

## Cable Data

Data sheets for these cables are found in the "Cables" chapter of this manual.

## Terminal Block Data

Data for the terminal block is found on the next page.

## IC693ACC337 TBQC Terminal Block

Use with the following 32-point I/O modules (2 required per module):

- IC693MDL654
- IC693MDL655
- IC693MDL752
- IC693MDL753

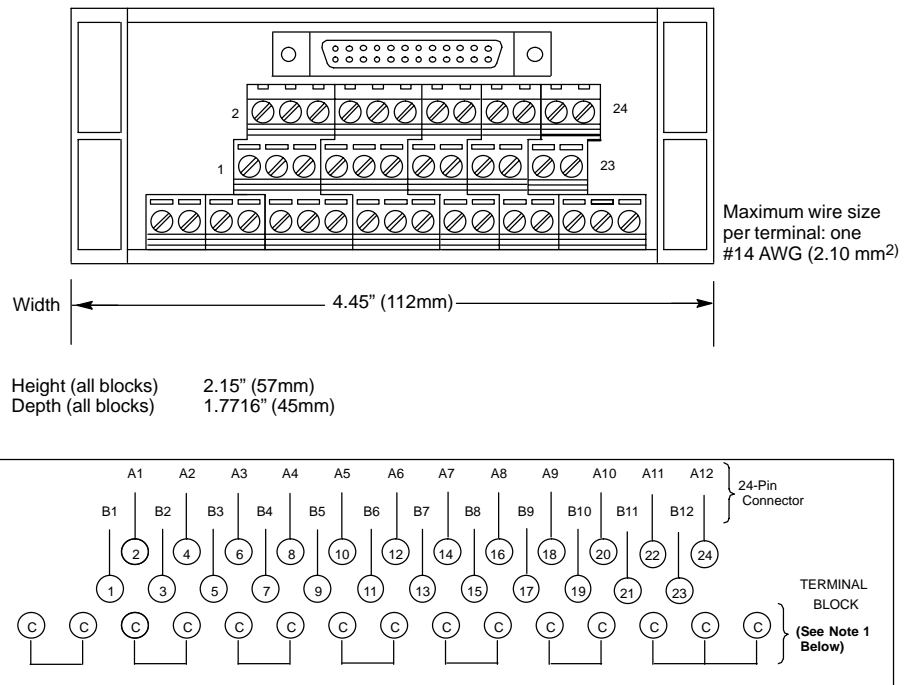

Figure J-9. IC693ACC337 TBQC Terminal Block

### Note

The common row terminals (labeled with the letter C) are provided for wiring convenience. Their use is optional. They are electrically isolated from the numbered terminals. You may use them as is, or jumper them to a numbered terminal. Refer to GFK-0898, *Series 90-30 PLC I/O Module Specifications Manual* for wiring diagrams of the modules.

### Mounting

These terminal blocks are mounted on a standard, user-supplied 35 mm DIN-rail.

### SNP Multidrop Overview

As used in this appendix, the term “SNP Multidrop” refers to a system that allows a programmer (called the “master or host”), such as a personal computer running GE Fanuc programming software, to connect to two or more PLCs or intelligent Option modules (called “slaves”) via a single connection. In this arrangement the programmer is able to program, configure, test, troubleshoot, etc., any one of the multidropped devices from one connection point.

Physically, a typical SNP multidrop system consists of a programmer and two or more PLCs interconnected by a “daisy-chain” type cabling arrangement, as shown in the figure below. It is necessary to assign each slave device (PLC or Option module) a unique SNP (Series Ninety Protocol) address, using programming software such as Logicmaster or VersaPro. The SNP address is used by the programmer to designate which PLC it will communicate with. The SNP protocol uses the RS-422 communications standard. Note that the PLCs or Option modules do not communicate with each other over the multidrop system. They only communicate with the programmer. And only one device, the one designated by the programmer, can communicate with the programmer at a time.

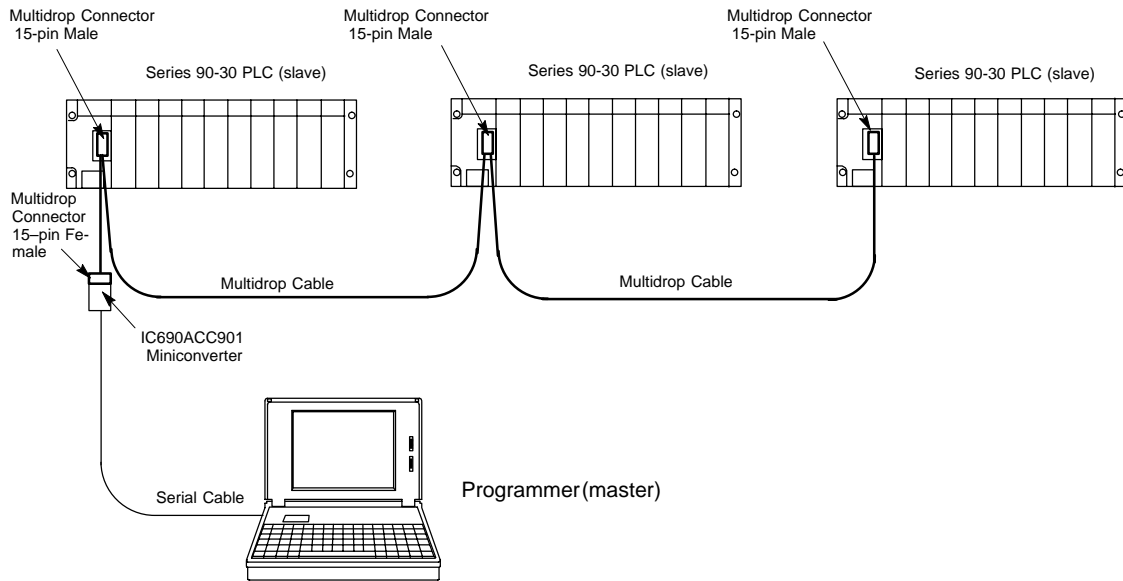

Figure K-1. Series 90-30 Multidrop Example

## Multidrop Cables

There are two sources of multidrop cables:

- **GE Fanuc cable, catalog number IC690CBL714A** – This pre-made cable can be purchased for applications where the PLCs are mounted in the same cabinet, such as in the case of redundant systems. The length of this cable is 40 inches (1 meter).
- **Custom built** – For PLCs that are more than 40 inches (1 meter) apart, it is necessary to build a custom length cable. The specifications are provide below.

## Limitations

- The maximum cable length between a master (programmer) and slave device (PLC or Option module) in a multidrop system is 4,000 feet (1,219 meters).
- The maximum number of slave devices is limited to eight.

## Cable and Connector Specifications

The cable assembly presents one of the most common causes of communication failure. For best performance, construct the cable assemblies using the recommended connector parts and specifications.

Table K-1. Connector and Cable Specifications

| Item       | Description  |
|------------|--|
| Connectors | <p><b>Series 90 PLC:</b> Serial (RS-422) port with metric hardware</p> <p>Connector: 15-pin male, D-Subminiature Type, Cannon DA15S (solder pot)<br/>                     Hood: AMP 207470-1 connector shell<br/>                     Hardware Kit: AMP 207871-1 Kit includes 2 metric screws and 2 screw clips</p>  |
|            | <p><b>Miniconverter:</b> For connecting to IC690ACC901 miniconverter</p> <p>Connector: 15-pin female, DB15F<br/>                     Hood: AMP #207470-1 or equivalent<br/>                     M3 Latchblocks: AMP #208101 or equivalent</p>  |
| Cable      | <p>Computer grade, 24 AWG (.22 mm<sup>2</sup>), minimum with overall shield</p> <p>Catalog Numbers: Belden 9505, Belden 9306, Belden 9832</p> <p>These cables provide acceptable operation for data rates up to 19.2 Kbps as follows:</p> <p>RS-422/RS-422: 4000 feet (1200 meters) maximum length. Must not exceed the maximum RS-422 Common Mode specification of +7V to -7V. Isolation at the remote end may be used to reduce or eliminate Common Mode voltages.</p> <p>When using RS-422/RS-422, the twisted pairs should be matched so that both transmit signals make up one twisted pair and both receive signals make up the other twisted pair. If this is ignored, cross-task resulting from the mismatching will affect the performance of the communications system.</p> <p>When routing communication cables outdoors, transient suppression devices can be used to reduce the possibility of damage due to lightning or static discharge.</p> <p><i>Care should be exercised that all connected devices are grounded to a common point. Failure to do so could result in damage to the equipment.</i></p> |

## MultiDrop Cable Wiring Diagram

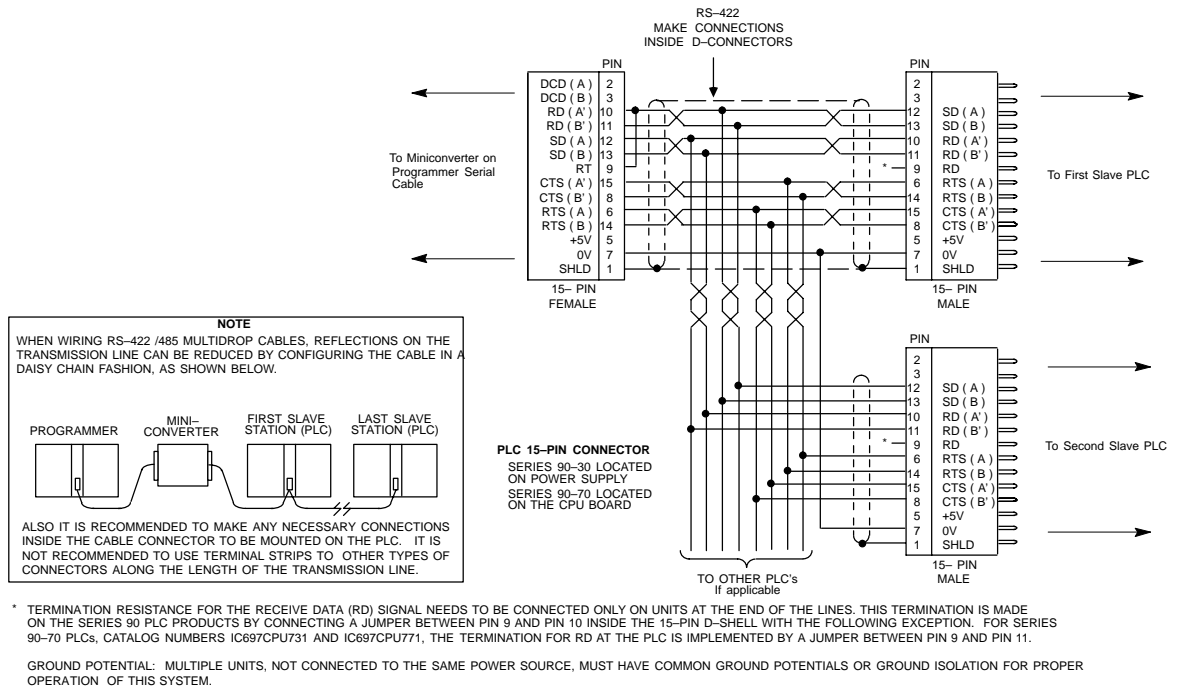

## SNP Multidrop Examples

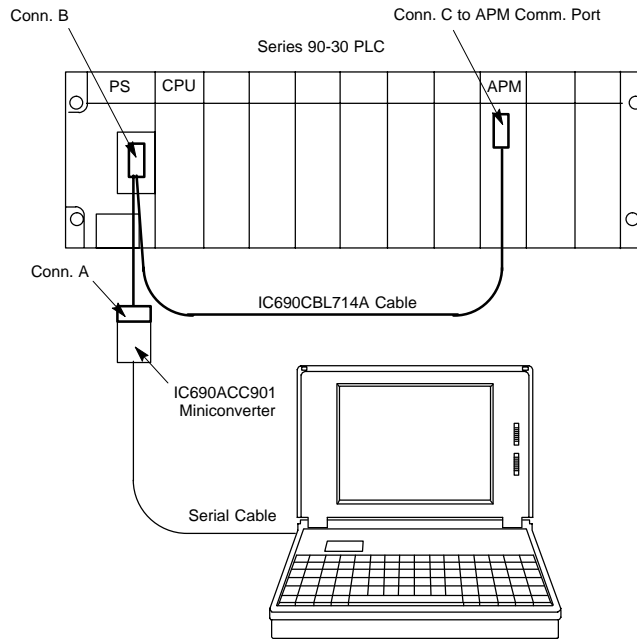

Figure K-3. Connecting CPU and APM to Programmer with IC690CBL714A Cable

a47100

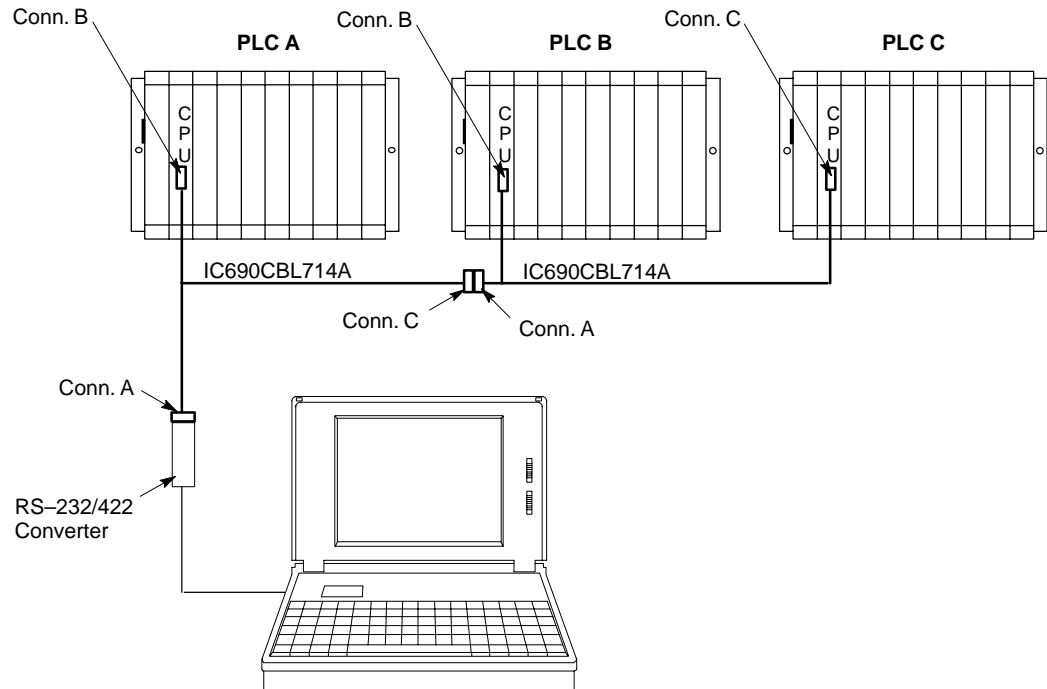

Figure K-4. Multidrop Arrangement for Series 90-70 TMR Redundant System

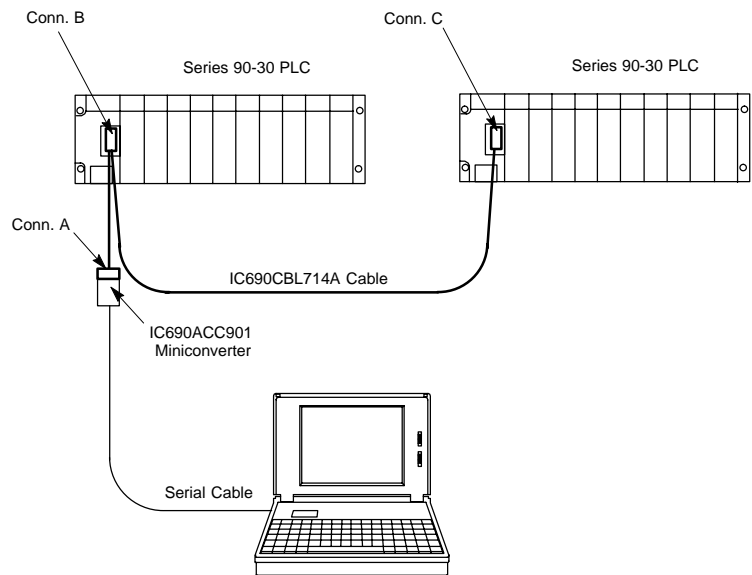

Figure K-5. Multidrop Arrangement for Series 90-30 Redundant System

## Configuring and Connecting a Programmer to a Multidrop Network

Each slave device on a multidrop system must have its own unique SNP ID (identification). The SNP ID assignment is made with a programmer running GE Fanuc programming software, or with the Hand Held Programmer. Logicmaster, Control, or Versa Pro software packages all can be used for this purpose. The following example uses Logicmaster. Please see your software user's manual or on-line help screens for instructions. Regardless of what software you use, the basic steps are:

- Connect your programmer to each individual PLC or module on the multidrop system and assign each one a unique SNP ID.
- Connect your programmer to the multidrop system and select Multidrop for the programmer's connection method.
- In the programming software, select the SNP ID of the PLC or module you wish to connect to.

### Assigning a PLC SNP ID to a PLC with Logicmaster

- Take your programmer to the first PLC to be assigned, and connect directly to its programmer port.
- From the Logicmaster Main Menu, select F2, "Logicmaster 90 Configuration Package."
- Select F2, "CPU Configuration."
- Put the software in the ONLINE mode.
- Select F3, "Assign PLC ID." On the ASSIGN PLC ID screen, the CURRENT PLC ID field will display an ID if the PLC has one. If the PLC does not currently have an SNP ID, this field will be blank. (In the OFFLINE mode it will display a series of asterisks.)

- Key in the new PLC ID. For newer CPUs, it may be from one to seven alpha-numeric characters long. For older CPUs, it is limited to a maximum of six characters. For example, it could be PLC1, APM001, A1, B00001, etc.
- Press the Enter key. The new SNP ID will be written to the PLC and the CURRENT PLC ID field on your screen will update to show this new SNP ID.
- Repeat the above steps for each PLC that is on the multidrop system. If assigning an SNP ID to a module, you must use the appropriate software. See the user's manual for the module for instructions.

### Connecting your Logicmaster Programmer to a PLC on a Multidrop System

- Connect your programmer to the programmer connection for the multidrop system.
- From the Logicmaster Main Menu, select F2, "Logicmaster 90 Configuration Package."
- Select F7, "Programmer Mode and Setup."
- Select F3, "Select PLC Connections."
- In the SELECTED SNP ID field, enter the SNP ID of the PLC or device you wish to communicate with.
- In the PORT CONNECTION field, select MULTIDROP.
- Press F6, "setup," to connect to the selected PLC. You should connect to the selected PLC within a few seconds. If you cannot connect, see the next section.

## SNP Multidrop Troubleshooting

If you are having trouble connecting to a PLC or module over the multidrop system, check the following:

- **Is there a problem with all PLCs or only one?** Try connecting to other PLCs over the multidrop system. If you cannot connect to any, check for a common problem such as a defective cable. If you can connect to all but one PLC, use the direct connection method described in the next paragraph. Also, if you only have a problem with the last PLC on the multidrop link, the last section of cable may have a problem. Or, perhaps you can connect to all PLCs up to a certain point, but none beyond that point. This would also strongly suggest that there is a problem in a section of cable.
- **SNP ID may be incorrect.** You may not be able to connect because you are specifying the wrong SNP ID. If you are not sure of a PLC's correct SNP ID and would like to check it, you can connect your programmer directly to the PLC's programmer port and read its SNP ID from the software's ASSIGN PLC ID screen, (as described in "Assigning an SNP ID to a PLC with Logicmaster," above). Make sure you change the programming software's connection method to Direct for this test. When set for Direct connection, the software will communicate with a directly connected PLC without regard to its SNP ID.
- **Communications settings may not match.** If the PLC's serial port communication settings and the programming software's communication settings do not match, they will not be able to communicate. These settings include such things as BAUD Rate, Parity, Stop Bits, etc. If you suspect this to be the problem, try connecting directly to the PLC as described above in "SNP ID may be incorrect." If you cannot

---

connect directly, there may be a communication settings mismatch. If so, try setting the programming software to its default communication settings.

- **Multidrop may not be selected as the connection method.** The default connection method in the programming software is Direct, which requires that you be connected directly to a PLC or module's programmer port. If this default setting is not changed to Multidrop, you will not be able to connect to a selected SNP ID over a multidrop system.
- **You may have a hardware problem.** Inspect the multidrop cable; it may be wired incorrectly, damaged, or disconnected. A wire may be loose on one of the connectors. Also check the status of the PLC you are trying to connect to. It may not be powered up; it may be stopped; or it may have some other problem. Eliminate the PLC itself as a possible problem by connecting your programmer directly to the PLC's programmer port. You should be able to communicate with a PLC using this direct connection even if the programming software is configured for Multidrop, as long as the SNP IDs match.

# Appendix L

## Ethernet Transceivers

[efesotomasyon.com](http://efesotomasyon.com)

### IC649AEA102 Ethernet 10BASE-T Transceiver

- Compliant with the IEEE 802.3 Ethernet specification for 10BASE-T.
- Connector on transceiver body is standard RJ-45 type for connection to unshielded twisted pair (UTP) Ethernet cable. .
- This unit has an attached 40" (1 meter) cable with standard 14-pin AAUI connector for connecting to a Series 90-30 Ethernet module (IC693CMM321) or CPU with Ethernet interface (IC693CPU364).
- SQE option is enabled.
- Power and Link Integrity LED indicator lights.

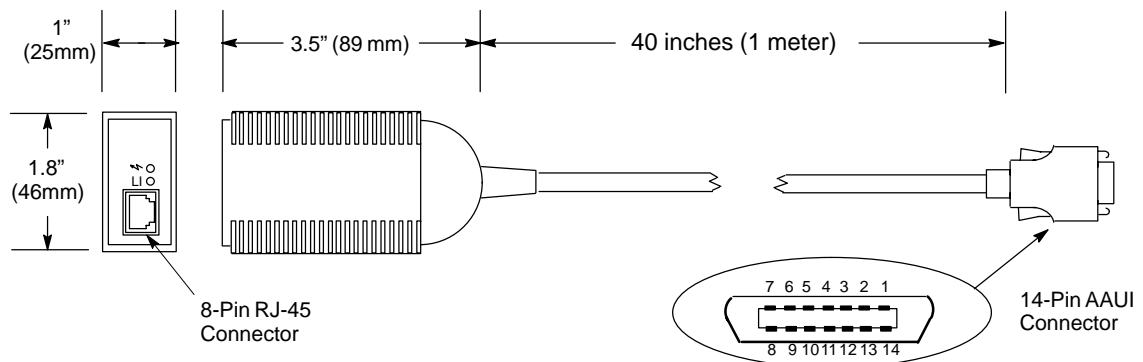

Figure L-1. IC649AEA102 Ethernet 10BASE-T Transceiver

### Power Requirement

This unit draws 60 mA @ 5Vdc from the Ethernet interface via the AAUI connector.

### LED Indicator Lights

These are located on the end of the unit next to the RJ-45 connector. The one labeled LI stays on as long as Link Integrity is maintained. The one marked with a "jagged arrow" symbol indicates the presence of 5Vdc power to the unit.

## IC649AEA103 Ethernet 10BASE2 Transceiver

**Note: This transceiver replaces obsolete catalog number IC649AEA101**

- Compliant with the IEEE 802.3 Ethernet specification for 10BASE2.
- A standard BNC connector is mounted on the body of the transceiver for connection to thin coaxial Ethernet cable.
- This unit has an attached 10" (254 mm) cable with standard 14-pin AAUI connector for connecting to a Series 90-30 Ethernet module (IC693CMM321) or CPU with Ethernet interface (IC693CPU364).
- SQE slide switch is set to enabled position at the factory. It must be in this position for proper operation with GE Fanuc Ethernet products IC693CMM321 and IC693CPU364 (see figure below).
- Power LED indicator light.

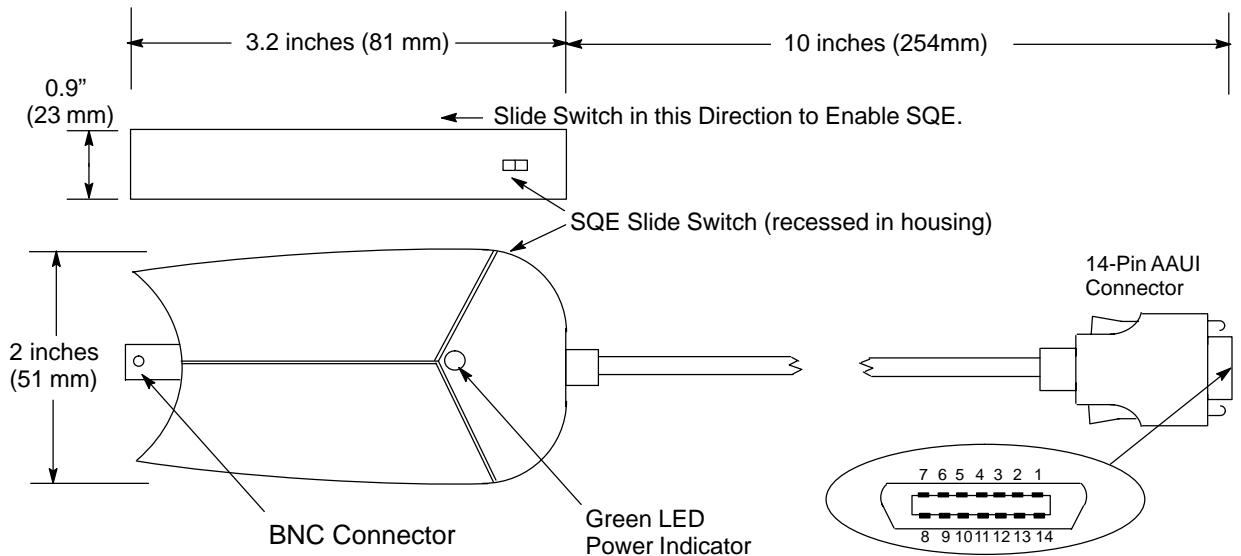

Figure L-2. IC649AEA103 Ethernet 10BASE2 Transceiver

### Power Requirement

This unit draws 400 mA @ 5Vdc from the Ethernet Interface via the AAUI connector.

### LED Indicator Light

Located on the side of the unit as shown in the figure. This green LED turns on to indicate the presence of 5Vdc power to the unit.

Table M-1. Standard ASCII (American Standard Code for Information Interchange) Codes

| Char. | Dec. | Hex. | Char. | Dec. | Hex. | Char. | Dec. | Hex. |
|-------|------|------|-------|------|------|-------|------|------|
| NUL   | 0    | 00   | +     | 43   | 2B   | V     | 86   | 56   |
| SOH   | 1    | 01   | ,     | 44   | 2C   | W     | 87   | 57   |
| STX   | 2    | 02   | -     | 45   | 2D   | X     | 88   | 58   |
| ETX   | 3    | 03   | .     | 46   | 2E   | Y     | 89   | 59   |
| EOT   | 4    | 04   | /     | 47   | 2F   | Z     | 90   | 5A   |
| ENQ   | 5    | 05   | 0     | 48   | 30   | [     | 91   | 5B   |
| ACK   | 6    | 06   | 1     | 49   | 31   | \     | 92   | 5C   |
| BEL   | 7    | 07   | 2     | 50   | 32   | ]     | 93   | 5D   |
| BS    | 8    | 08   | 3     | 51   | 33   | ^     | 94   | 5E   |
| HT    | 9    | 09   | 4     | 52   | 34   | _     | 95   | 5F   |
| LF    | 10   | 0A   | 5     | 53   | 35   | `     | 96   | 60   |
| VT    | 11   | 0B   | 6     | 54   | 36   | a     | 97   | 61   |
| FF    | 12   | 0C   | 7     | 55   | 37   | b     | 98   | 62   |
| CR    | 13   | 0D   | 8     | 56   | 38   | c     | 99   | 63   |
| SO    | 14   | 0E   | 9     | 57   | 39   | d     | 100  | 64   |
| SI    | 15   | 0F   | :     | 58   | 3A   | e     | 101  | 65   |
| DLE   | 16   | 10   | ;     | 59   | 3B   | f     | 102  | 66   |
| DC1   | 17   | 11   | <     | 60   | 3C   | g     | 103  | 67   |
| DC2   | 18   | 12   | =     | 61   | 3D   | h     | 104  | 68   |
| DC3   | 19   | 13   | >     | 62   | 3E   | i     | 105  | 69   |
| DC4   | 20   | 14   | ?     | 63   | 3F   | j     | 106  | 6A   |
| NAK   | 21   | 15   | @     | 64   | 40   | k     | 107  | 6B   |
| SYN   | 22   | 16   | A     | 65   | 41   | l     | 108  | 6C   |
| ETB   | 23   | 17   | B     | 66   | 42   | m     | 109  | 6D   |
| CAN   | 24   | 18   | C     | 67   | 43   | n     | 110  | 6E   |
| EM    | 25   | 19   | D     | 68   | 44   | o     | 111  | 6F   |
| SUB   | 26   | 1A   | E     | 69   | 45   | p     | 112  | 70   |
| ESC   | 27   | 1B   | F     | 70   | 46   | q     | 113  | 71   |
| FS    | 28   | 1C   | G     | 71   | 47   | r     | 114  | 72   |
| GS    | 29   | 1D   | H     | 72   | 48   | s     | 115  | 73   |
| RS    | 30   | 1E   | I     | 73   | 49   | t     | 116  | 74   |
| US    | 31   | 1F   | J     | 74   | 4A   | u     | 117  | 75   |
| SP    | 32   | 20   | K     | 75   | 4B   | v     | 118  | 76   |
| !     | 33   | 21   | L     | 76   | 4C   | w     | 119  | 77   |
| ”     | 34   | 22   | M     | 77   | 4D   | x     | 120  | 78   |
| #     | 35   | 23   | N     | 78   | 4E   | y     | 121  | 79   |
| \$    | 36   | 24   | O     | 79   | 4F   | z     | 122  | 7A   |
| %     | 37   | 25   | P     | 80   | 50   | {     | 123  | 7B   |
| &     | 38   | 26   | Q     | 81   | 51   |       | 124  | 7C   |
| '     | 39   | 27   | R     | 82   | 52   | }     | 125  | 7D   |
| (     | 40   | 28   | S     | 83   | 53   | ~     | 126  | 7E   |
| )     | 41   | 29   | T     | 84   | 54   | “     | 127  | 7F   |
| *     | 42   | 2A   | U     | 85   | 55   |       |      |      |

## AWG to Metric Wire Size Conversion

Since there is not an exact correspondence between American AWG wire sizes and metric sizes, the metric values in the following table are close approximations. If you need greater precision, contact your wire supplier.

Table M-2. AWG to Metric Wire Size Conversion

| AWG to Metric Wire Size Conversion |   |
|------------------------------------|---|
| AWG Size                           | Metric Cross Section in square millimeters (mm <sup>2</sup> ) |
| 1                                  | 42.4  |
| 2                                  | 33.6  |
| 4                                  | 21.2  |
| 6                                  | 13.2  |
| 8                                  | 8.37  |
| 10                                 | 5.26  |
| 12                                 | 3.31  |
| 14                                 | 2.08  |
| 16                                 | 1.31  |
| 18                                 | 0.82  |
| 20                                 | 0.52  |
| 22                                 | 0.32  |
| 24                                 | 0.21  |
| 26                                 | 0.13  |
| 28                                 | 0.081   |
| 30                                 | 0.051   |

## Temperature Conversion

### Formulas

$$^{\circ}\text{C} = 5/9(^{\circ}\text{F} - 32)$$

$$^{\circ}\text{F} = (9/5 \times ^{\circ}\text{C}) + 32$$

Table M-3. Celsius to Fahrenheit Conversion

| Celsius to Fahrenheit Conversion (to nearest degree) |                    |                 |                    |                 |                    |
|--|--------------------|-----------------|--------------------|-----------------|--------------------|
| Degrees Celsius                                      | Degrees Fahrenheit | Degrees Celsius | Degrees Fahrenheit | Degrees Celsius | Degrees Fahrenheit |
| -50  | -58                | 50              | 122                | 145             | 293                |
| -45  | -49                | 55              | 131                | 150             | 302                |
| -40  | -40                | 60              | 140                | 155             | 311                |
| -30  | -22                | 65              | 149                | 160             | 320                |
| -25  | -13                | 70              | 158                | 165             | 329                |
| -20  | -4                 | 75              | 167                | 170             | 338                |
| -15  | 5                  | 80              | 176                | 175             | 347                |
| -10  | 14                 | 85              | 185                | 180             | 356                |
| -5   | 23                 | 90              | 194                | 185             | 365                |
| 0  | 32                 | 95              | 203                | 190             | 374                |
| 5  | 41                 | 100             | 212                | 195             | 383                |
| 10   | 50                 | 105             | 221                | 200             | 392                |
| 15   | 59                 | 110             | 230                | 205             | 401                |
| 20   | 68                 | 115             | 239                | 210             | 410                |
| 25   | 77                 | 120             | 248                | 215             | 419                |
| 30   | 86                 | 125             | 257                | 220             | 428                |
| 35   | 95                 | 130             | 266                | 225             | 437                |
| 40   | 104                | 135             | 275                | 230             | 446                |
| 45   | 113                | 140             | 284                | 235             | 455                |

## Conversion Information

Table M-4. General Conversions

|                                    |                               |
|------------------------------------|-------------------------------|
| 1 ounce (weight) =                 | 28.35 grams                   |
| 1 pound (weight) =                 | 453.6 grams                   |
| 1 pound (weight) =                 | 16 ounces                     |
| 1 pound (force) =                  | 4.448 newtons                 |
| 1 short ton (weight)=              | 907.2 kilograms               |
| 1 short ton (weight)=              | 2,000 pounds                  |
| 1 horsepower (power)=              | 550 foot-pounds per second    |
| 1 horsepower (power) =             | 746 watts of electrical power |
| 1 kilowatt (power) =               | 1.341 horsepower              |
| 1 kilowatt-hour (energy or work) = | 3,412.142 Btu                 |
| 1 kilowatt-hour (energy or work) = | 1,000 watts/hr.               |
| 1 watt (power) =                   | 3.412 Btu/hr.                 |
| 1 watt (power) =                   | 1 joule/sec.                  |
| 1 joule/sec. (power) =             | 1 watt                        |
| 1 joule (energy)=                  | 1 newton-meter                |
| 1 Btu =                            | 0.293 watt                    |
| 1 Btu =                            | 778.2 foot-pounds             |
| 1 Btu =                            | 252 gram-calories             |
| 1 Btu (energy)=                    | 1055 joules                   |
| 1 newton-meter (torque or work) =  | 0.7376 pound-feet             |
| 1 newton-meter (torque or work) =  | 8.851 pound-inches            |
| 1 pound-foot (torque or work) =    | 1.3558 newton-meters          |
| 1 pound-inch (torque or work) =    | 0.113 newton-meters           |
| 1 ounce-inch (torque or work) =    | 72 gram-centimeters           |
| 1 degree (angular) =               | 0.0175 radians                |
| 1 minute (angular) =               | 0.01667 degrees               |
| 1 radian (angular) =               | 57.3 degrees                  |
| 1 quadrant (angular) =             | 90 degrees                    |

## English and Metric Equivalents

This section is based upon information published on the World Wide Web by the U.S. government's National Institute of Standards and Technology (NIST). For further information, visit their web site at [www.nist.gov](http://www.nist.gov).

Table M-5. Length Equivalents

| Units of Length (Underlined Figures are Exact) |               |              |              |                  |                  |                  |
|--|---------------|--------------|--------------|------------------|------------------|------------------|
| Units  | Inches        | Feet         | Yards        | Millimeters      | Centimeters      | Meters           |
| 1 inch =                                       | <u>1</u>      | 0.083 333    | 0.027 777    | <u>25.4</u>      | <u>2.54</u>      | <u>0.025 4</u>   |
| 1 foot =                                       | <u>12</u>     | <u>1</u>     | 0.333 333    | <u>304.8</u>     | <u>30.48</u>     | <u>0.304 8</u>   |
| 1 yard =                                       | <u>36</u>     | <u>3</u>     | <u>1</u>     | <u>914.4</u>     | <u>91.44</u>     | <u>0.914 4</u>   |
| 1 mile =                                       | <u>63,360</u> | <u>5,280</u> | <u>1,760</u> | <u>1,609,344</u> | <u>160,934.4</u> | <u>1,609.344</u> |
| 1 mm =   | 0.0393 700    | 0.003 280 8  | 0.001 093 6  | <u>1</u>         | <u>.1</u>        | <u>.001</u>      |
| 1 cm =   | 0.393 700 8   | 0.032 808    | 0.010 936    | <u>10</u>        | <u>1</u>         | <u>0.01</u>      |
| 1 meter =                                      | 39.370 08     | 3.280 840    | 1.093 613    | <u>1000</u>      | <u>100</u>       | <u>1</u>         |

Table M-6. Area Equivalents

| Units of Area (Underlined Figures are Exact) |                      |                   |                  |                          |                          |
|--|----------------------|-------------------|------------------|--------------------------|--------------------------|
| Units  | Square Inches        | Square Feet       | Square Yards     | Square Centimeters       | Square Meters            |
| 1 square inch =                              | <u>1</u>             | 0.006944          | 0.000 771 604 9  | <u>6.451 6</u>           | <u>0.000 645 16</u>      |
| 1 square foot =                              | <u>144</u>           | <u>1</u>          | 0.111111         | <u>929.030 4</u>         | <u>0.092 903 04</u>      |
| 1 square yard =                              | <u>1296</u>          | <u>9</u>          | <u>1</u>         | <u>8,361.273 6</u>       | <u>0.836 127 36</u>      |
| 1 square mile =                              | <u>4,014,489,600</u> | <u>27,878,400</u> | <u>3,097,600</u> | <u>25,899,881,103.36</u> | <u>2,589,988.110 336</u> |
| 1 square centimeter =                        | 0.155 000 3          | 0.001 076 391     | 0.0001195990     | <u>1</u>                 | <u>0.0001</u>            |
| 1 square meter =                             | 1,550.003            | 10.763 91         | 1.195 990        | <u>10,000</u>            | <u>1</u>                 |

Table M-7. Volume Equivalents I

| <b>Units of Volume (Underlined Figures are Exact)</b> |                     |                   |                    |
|---|---------------------|-------------------|--------------------|
| <b>Units</b>  | <b>Cubic Inches</b> | <b>Cubic Feet</b> | <b>Cubic Yards</b> |
| 1 cubic inch =  | <u>1</u>            | 0.000 578 703 7   | 0.000 021 433 47   |
| 1 cubic foot =  | <u>1,728</u>        | <u>1</u>          | 0.037 037 04       |
| 1 cubic yard =  | <u>46,656</u>       | <u>27</u>         | <u>1</u>           |
| 1 cubic centimeter =                                  | 0.061 023 74        | 0.000 035 314 67  | 0.000 001 307 951  |
| 1 cubic decimeter =                                   | 61.023 74           | 0.035 314 67      | 0.001 307 951      |
| 1 cubic meter   | 61,023.74           | 35.314 67         | 1.307 951          |

Table M-8. Volume Equivalents II

| <b>Units of Volume (Underlined Figures are Exact)</b> |  |                                      |                          |
|---|--|--------------------------------------|--------------------------|
| <b>Units</b>  | <b>Milliliters<br/>(Cubic Centimeters)</b> | <b>Liters<br/>(Cubic Decimeters)</b> | <b>Cubic Meters</b>      |
| 1 cubic Inch =  | <u>16.387 064</u>                          | <u>0.016 387 064</u>                 | <u>0.000 016 387 064</u> |
| 1 cubic foot =  | <u>28,316.846 592</u>                      | <u>28.316 846 592</u>                | <u>0.028 316 846 592</u> |
| 1 cubic yard =  | <u>764,554.857 984</u>                     | <u>764.554 857 984</u>               | <u>0.764 554 857 984</u> |
| 1 cubic centimeter =                                  | <u>1</u>                                   | <u>0.001</u>                         | <u>0.000 001</u>         |
| 1 cubic decimeter =                                   | <u>1,000</u>                               | <u>1</u>                             | <u>0.001</u>             |
| 1 cubic meter =                                       | <u>1,000,000</u>                           | <u>1,000</u>                         | <u>1</u>                 |

Appendix  
N

44A720084-001 EMI Line Filter

44A720084-001 Optional EMI Line Filter

Note

**This product is not required on later versions of the Series 90-30 PLC. This information is provided as a reference for those already using this product. This item is still available for purchase from GE Fanuc.**

Early versions of the Series 90-30 PLC and its associated hardware components were designed primarily for use in industrial applications which are, in general, exempted from FCC requirements. The AC power supply in those early PLCs may not comply with FCC requirements in non-industrial applications for conducted EMI on AC power lines. In a situation where it was desired to satisfy the FCC requirements for non-industrial applications, a line filter was used in series with the AC power line input. **Later versions of the Series 90-30 PLC meet FCC requirements and do not require a separate line filter.**

A line filter that satisfies the FCC requirements for non-industrial applications is available from GE Fanuc as part number 44A720084-001. A wiring diagram for connecting the line filter in a Series 90-30 PLC system is shown below.

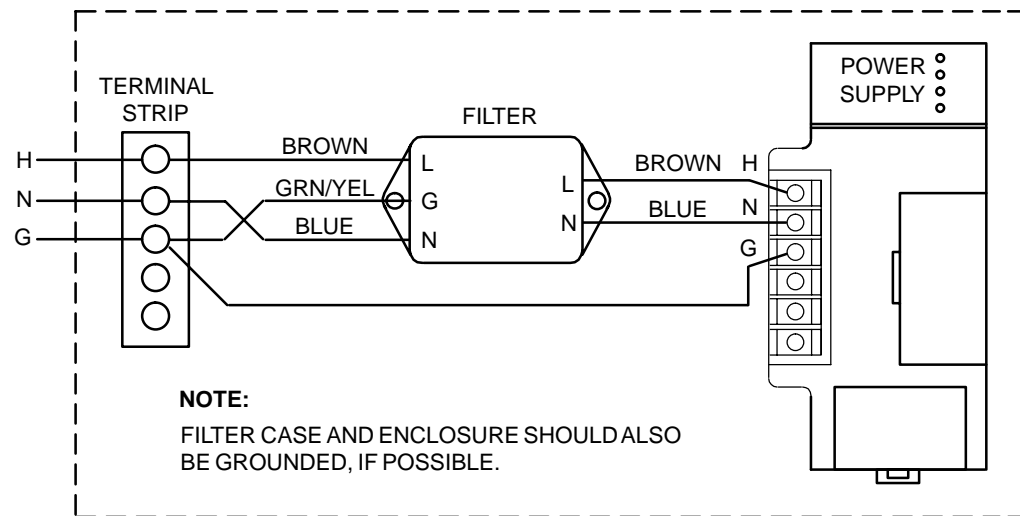

Figure N-1. 44A720084-001 Line Filter Connections to Series 90-30 Power Supply

The equivalent circuit for the line filter is shown below. This is provided in case you wish to specify or design a line filter as an alternative to the one mentioned above.

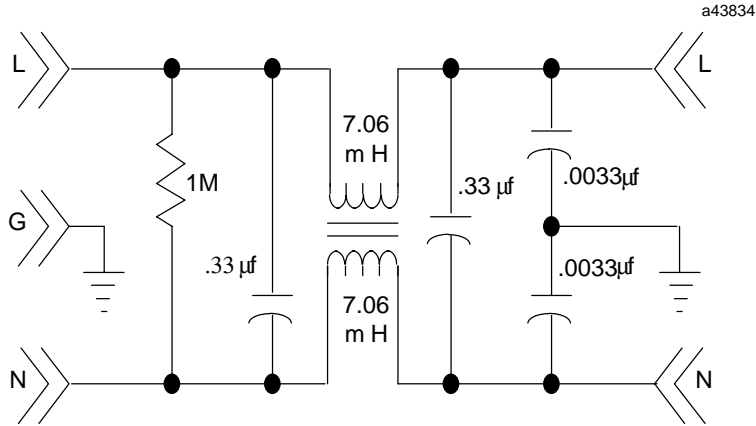
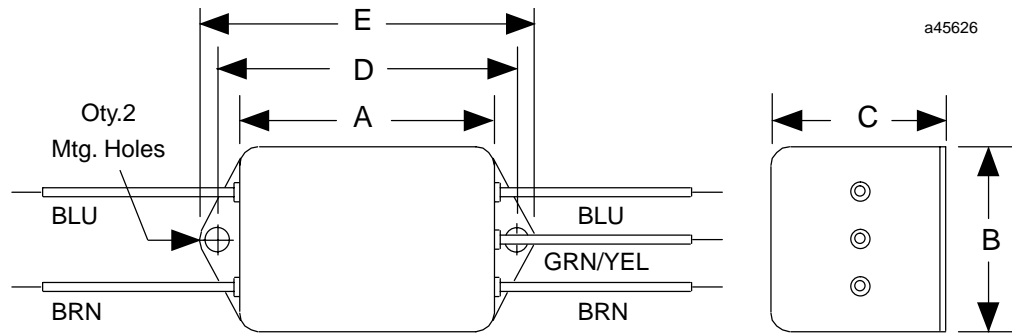

Figure N-2. Equivalent Circuit for 44A720084-001 Line Filter

### 44A720084-001 Line Filter Mounting Dimensions



| Dimension   | A     | B     | C     | D           | E     | Mounting Holes |
|-------------|-------|-------|-------|-------------|-------|----------------|
| Inches      | 2.09  | 1.84  | 1.29  | 2.375 ±.010 | 2.75  | (2) .187 ±.008 |
| Millimeters | 53.09 | 46.74 | 32.77 | 60.32 ±.25  | 69.85 | (2) 4.75 ±.020 |

Figure N-3. 44A720084-001 Line Filter Mounting Dimensions

## Numbers

- 10BASE-T, Ethernet transceiver, [L-1](#)
- 10BASE2, Ethernet transceiver, [L-2](#)
- 32-Point modules
  - figure, [7-6](#), [7-7](#)
  - installation, [2-20](#)
  - installing, [2-19](#)
  - TBQC, [J-11](#)
  - wiring, [7-8](#)
- 44A720084-001, EMI line filter, [N-1](#)

## A

- AAUI
  - connector on CPU364, [5-23](#)
  - connector on transceiver, [L-2](#)
- AAUI (transceiver) port, [8-31](#)
- AC/DC high capacity power supply
  - illustration of, [4-4](#)
  - overvoltage protection devices, [2-24](#)
  - specifications, [4-5](#)
- AC/DC power supplies
  - overcurrent protection, [4-19](#)
  - status indicators, [4-17](#)
  - timing diagram, [4-19](#)
- AC/DC standard power supply
  - ac power source connections, [4-5](#)
  - dc power source connections, [4-5](#)
  - illustration of, [4-2](#)
  - overvoltage protection devices, [2-24](#), [4-5](#), [4-17](#)
  - specifications, [4-3](#)
- Accompany Program, [8-1](#)
- Acronyms and abbreviations, [B-1](#)
- AD693CMM301
  - module drawing, [9-2](#)
  - State Logic Serial Module, [9-2](#)
- AD693SLP300, State Logic processor, [9-4](#)
- Adapter bracket for 10-slot baseplate, [2-8](#), [3-22](#)
- ADC
  - Alphanumeric Display Coprocessor, [8-35](#)
  - Wye cable, [10-36](#)
- Address, Memory, [5-11](#)

## Analog I/O modules

- Figure, [7-11](#)
- Wiring methods, [2-21](#), [7-11](#)

## APM

- Axis Positioning Module, [8-15](#)
- Cable data sheets, [10-45](#)

## Appendices

- acronyms and abbreviations, [B-1](#)
- Catalog num to pub num, [I-1](#)
- Ethernet transceivers, [L-1](#)
- glossary of terms, [A-1](#)
- IC690ACC903 Port Isolator, [G-1](#)
- isolated repeater/converter, [E-1](#)
- miniconverter kit, [F-1](#)
- RS-422/RS-485 to RS-232 converter, [D-1](#)
- serial port and cables, [C-1](#)
- Series 90-30 heat dissipation, [H-1](#)
- SNP multidrop, [K-1](#)
- Tables and Formulas, [M-1](#)
- Terminal Block Quick Connect, [J-1](#)
- Axis Positioning Module, (APM), [8-15](#)

## B

### Backplane

- Baseplate, [3-14](#)
- Definition, [3-3](#)

### Backup, User program, [6-3](#)

### Backup battery, [4-20](#)

### Baseplate

- Comparison table, [3-24](#)
- expansion dimensions, [3-19](#)
- Grounding, [2-12](#)
- Modular CPU dimensions, [3-19](#)
- Mounting, [2-8](#)
- remote 10-slot, [3-11](#)
- remote 5-slot, [3-10](#)
- remote dimensions, [3-19](#)
- selecting, [12-6](#)

### Baseplate adapter bracket

- for 10-slot baseplate, [2-8](#), [3-22](#)
- installation, [2-9](#), [3-22](#)

### Baseplate installation, [3-18](#)

- mounting requirements, model 311/313/323, [3-18](#)

### Baseplate, remote, figure, [3-10](#)

### Baseplates

- adapter bracket, [2-8](#), [3-22](#)
- Common features, [3-1](#)

- dimensions for mounting, 10-slot, 3-19, 3-20
  - dimensions for mounting, 5-slot, 3-18, 3-19
  - Embedded CPU dimensions, 3-18
  - Expansion, 3-8
  - Expansion and Remote in same system, 3-13
  - Expansion, features, 3-8
  - Mounting dimensions, 3-18
  - mounting in 19" rack, 2-9, 3-23
  - number in FIP Nest, 8-12
  - power supply location, 4-2
  - Remote, features, 3-10
  - Serial number location, 3-2
  - Sizes, 3-2
  - Terminology, 3-3
  - Types, 3-1
- Battery**
- CPU memory backup, 6-1
  - Date code, 6-6
  - Determining age, 6-6
  - installation, accessory kit, 6-9
  - Life, 6-4
  - Low warning, 6-4
  - Memory backup, 4-20
  - Operating without, 6-5
  - RAM backup path, 6-6
  - Replacement strategy, 6-3
- Battery accessory kit, For embedded CPUs, 6-8**
- Blocks, Genius, 8-6**
- Bracket, adapter, 2-8, 3-22**
- Bus, connectors, 8-11**
- Bus controller, FIP, 8-10**
- Bus interface, 8-13**
- 
- ## C
- Cable**
- 32-point I/O, 10-42, 10-49
  - APM, 10-45
  - Building 32-point, 10-59
  - cross-reference table, 10-1
  - Data sheet list, 10-8
  - Extension for I/O module, 10-39
  - HHP, 10-34
  - I/O bus expansion, 10-23
  - I/O for 32-point modules, 10-41
  - I/O interface, 10-54, 10-57
  - IC690CBL714A multidrop, 10-19
  - Programmer, 10-13, 10-15, 10-17
  - PTM interface, 10-65
  - WSI, 10-9
  - Wye port expansion, 10-36
- Cable and connections for serial port, C-2 multidrop cable, K-2**
- Cable diagrams for isolated repeater/converter, E-7**
- Cable diagrams, serial connection, C-7**
- Cable for Series 90-30 installations**
- extension cable for 32 point modules, 10-39, 10-54, 10-62
  - hand-held programmer cable, 10-34
  - I/O cable for 32 point modules, 10-41
  - I/O cable for Power Mate APM to terminal block, 10-45
  - I/O interface cable for 32 point I/O modules, 10-42, 10-49, 10-57
  - pcm to PC-AT, 10-15
  - pcm to Workmaster (PC-XT), 10-13
  - pcm to Workmaster II (PS/2), 10-17
  - work station interface cable, 10-9
  - wye cable wiring diagram, earlier version baseplates, 10-30
  - wye cables, 10-36
- Cable for Series 90-30 Installations, shield treatment, 10-27**
- Cables**
- APM, 8-16
  - building I/O Bus Expansion, 10-23
  - I/O Expansion Bus, 3-12
  - SNP multidrop, K-2
- Calculations for power supply loads, examples, 12-15**
- Catalog, Automation Solutions, 7-2, 8-1**
- Catalog number, CPU, 5-7**
- Catalog number location, Baseplate, 3-2**
- Catalog numbers, cables**
- IC647CBL704, 10-9
  - IC693CBL304, 10-36
  - IC693CBL305, 10-36
- CCM, 8-34**
- CCM communications protocol, 8-34**
- CCM protocol, PCM module, 8-32**
- Clearance requirements, PLC rack, 12-17**
- CMM**
- Comm. Coprocessor Module, 8-34
  - Wye cable, 10-36

- CNC, 8-25
  - Color coding, Wires, 2-17
  - COM port, standard serial, 11-4
  - Comm. Coprocessor Module, IC693CMM311, 8-34
  - Communications, using datagrams, 8-6
  - Compatibility, User program to CPU type, 5-12
  - Configurable, Memory, 5-14
  - Configuration, Software, 8-19, 8-22
  - Conformance to standards, 2-1
  - Connector, serial port, 4-20, 5-3, 9-10
  - Converter
    - IC690ACC900, 11-4
    - IC690ACC901, 11-5
  - Converter board jumper configuration, D-8
  - Converter, RS-232/RS-485, C-7
  - Converters
    - IC655CCM590, E-1
    - IC690ACC900, D-1
    - IC690ACC901, F-1
    - IC690ACC903, 11-4
  - CPU
    - 350 hardware features, 5-18
    - 350-364 features, 5-13
    - 351 hardware features, 5-19
    - 352 hardware features, 5-19
    - 360 hardware features, 5-18
    - 363 hardware features, 5-19
    - 364 hardware features, 5-22
    - capacities, 5-10
    - Compatibility with HHP, 5-13
    - Data sheets contents, 5-24, 9-13
    - Embedded features figure, 5-2
    - Embedded overview, 5-1
    - Firmware, 5-6
    - Firmware upgrade, 5-6
    - jumpers for EPROM/EEPROM selection, model 331, 5-8
    - Keypad, 5-15
    - Memory size table, 5-11
    - Microprocessors, 5-3
    - Modular features figure, 5-3
    - Modular overview, 5-2
    - Revision level, 5-7
    - selecting, 12-4
    - serial port connector, 4-20, 5-3, 9-10
    - Serial ports, 5-15
    - speed, 5-10
    - State Logic, 9-8
    - state logic, model CSE 331, 9-10
    - state logic, model CSE 340, 9-10
    - Time of day clock accuracy, 5-12
    - Types, 5-1
  - CPU 350-364, Features table, 5-14
  - CPU 351, grounding information, 2-14
  - CPU 360-364, Features table, 5-14
  - CPU baseplate
    - Defined, 3-3
    - Types, 3-4
  - CPU baseplates
    - Embedded, 3-4
    - Modular, 3-6
  - CPU data sheets
    - CPU311, 5-25
    - CPU313, 5-26
    - CPU323, 5-27
    - CPU331, 5-28
    - CPU340, 5-29
    - CPU341, 5-30
    - CPU350, 5-31
    - CPU351, 5-32
    - CPU352, 5-33
    - CPU360, 5-34
    - CPU363, 5-35
    - CPU364, 5-36
    - CSE 311, 9-14
    - CSE 313, 9-15
    - CSE 323, 9-16
    - CSE 331, 9-17
    - CSE 340, 9-18
  - Cross reference, product to documentation, I-1
  - Current draw, module, 12-12
  - Customer service, telephone number, 2-1
- ## D
- Data, global, 8-8
  - Datagrams, 8-6
  - Date code, Battery, 6-6
  - DC high capacity power supply
    - 5 vdc current derating diagram, 4-14
    - calculating input power requirements, 4-15
    - capacities, 4-13

- illustration of, 4-13
  - output voltages to backplane, 4-18
  - specifications, 4-14
  - DC power supply
    - dc power connections, 4-16
    - input power requirements, calculating, 4-8, 4-11, 4-15
    - isolated +24 vdc supply connections, 4-6, 4-16
    - overcurrent protection, 4-19
    - specifications, 4-8, 4-11
    - status indicators, 4-17
    - timing diagram, 4-19
  - DC power supply (24/48 VDC), illustration of, 4-7
  - DC power supply (48 VDC), illustration of, 4-10
  - Default station address label, 8-31
  - Diagram, timing, 4-19
  - Digital Servo Module
    - DSM302, 8-17
    - DSM314, 8-20
  - Direct processing, definition, 8-28
  - Documentation, cross-reference, I-1
  - DOIO, instruction, 13-4
  - Drops, remote, 8-6
  - DSM
    - Digital Servo Module (DSM302), 8-17
    - Digital Servo Module (DSM314), 8-20
- ## E
- EEPROM, 5-5
  - Embedded baseplates, State Logic, 9-8
  - Embedded CPU baseplates, 3-4
    - Features (figure), 3-5
  - EMI, filter requirement, N-1
  - EMI line filter, 44A720084-001, N-1
  - Enhanced Genius Comm. Module, 8-4
  - EPROM, 5-5
    - Creating, 5-9
  - EPROM/EEPROM catalog numbers
    - IC693ACC305, 5-9
    - IC693ACC306, 5-9
  - Ethernet
    - CPU364 embedded, 5-17
    - transceiver, L-1, L-2
    - transceiver, obsolete, L-2
  - Ethernet interface, restart pushbutton, 8-31
  - Ethernet interface module, 8-30
    - board indicators, 8-31
  - Ethernet transceiver
    - IC649AEA102, L-1
    - IC649AEA103, 8-30, L-2
  - Expansion
    - baseplates, 3-8
    - bus termination, 3-13, 10-26
    - extension cables, description of, 10-39, 10-54, 10-62
    - port pin assignments, 10-26
  - Expansion baseplate
    - defined, 3-3
    - IC693CHS392 figure, 3-9
    - IC693CHS398 figure, 3-8
  - Expansion system
    - example, 3-16
    - remote connections, 3-17, 10-33
    - requirements of, 12-16
  - Extension cables, I/O, 10-39, 10-54, 10-62
- ## F
- Faceplate, I/O, J-3
  - Fax Link system, 13-8
  - FBC, FIP Bus Controller, 8-10
  - Features of the DSM302
    - Easy to Use, 8-18, 8-21
    - High Performance, 8-18, 8-21
  - Field Control, using with PLC, 12-7
  - Field control, 8-10
  - Field wiring, to AC/DC power supplies, 2-23
  - Field wiring connections
    - to dc input power supply, 4-16
    - to standard ac/dc power supply, 4-5
  - FIP bus, 8-12
  - FIP bus controller, 8-10
    - description, 8-11
  - FIP nest, description, 8-12

FIP remote I/O scanner, 8-12  
  connectors, 8-13  
  ground lug on module, 8-13  
  LEDs, 8-13

Firmware  
  CPU, 5-6  
  CPU table, 5-6  
  CPU upgrade, 5-6  
  CPU Version 9.0, 5-14  
  Upgrading 350–364 CPUs, 5-14

Firmware upgrade procedure for flash  
  memory, 5-7

Flash, Memory protection, 5-15

Flash memory, 5-5, 5-10, 5-15  
  firmware upgrade procedure, 5-7

Floating neutral (IT) systems, 2-25

Floating-point math, 5-15

Fuse, table of, 13-5

## G

GBC, Genius Bus Controller, 8-6

GCM  
  Example (figure), 1-9  
  Genius Comm. Module, 8-2

GCM+, Enhanced Genius Comm. Mod-  
  ule, 8-4

Genius Blocks, using with PLC, 12-7

Genius blocks, 8-6

Genius bus controller, 8-6  
  compatibility  
    hand-held monitor, 8-7  
    Logicmaster90-30/20/microsoftware,  
    8-7  
    Series 90-30 plc, 8-7  
    Series Six plc, 8-7  
  datagrams, 8-8  
  diagnostics, 8-8  
  global data operation, 8-8  
  number in system, 8-7  
  status LEDs, 8-2, 8-5, 8-7  
    COM, 8-2, 8-5, 8-7  
    OK, 8-2, 8-5, 8-7

Genius bus scan, 8-8

Genius Comm. Module, (GCM), 8-2

Genius hand-held monitor, 8-6, 8-7

Genius I/O blocks, 8-8

Global data, 8-6, 8-8  
  receiving, 8-9  
  sending, 8-9

Glossary of terms, A-1

Ground bracket, CPU351, 352 figure, 2-15

Ground conductor installation, 2-11

Ground connections  
  equipment, 2-12  
  programming device, 2-13  
  safety and reference, 2-12  
  shield ground, 2-14

Ground wire, CPU363, 364 figure, 2-16

Grounding procedures, 2-11  
  Baseplate, 2-12  
  CPU shield, 2-14  
  Module shield, 2-14  
  Option modules, 2-16  
  System, 2-11

Grounding procedures, Programmer, 2-13

## H

Hand-held programmer cable, description  
  of, 10-34

Hand-Held Programmer  
  Cable data sheet, 10-34  
  general description, 11-6

Hand-held programmer, CPU compati-  
  bility, 5-13

Hand-held monitor (Genius), compati-  
  bility, 8-7

Hand-held monitor, Genius, 8-6

Hand-held Programmer, function with  
  FIP I/O nest, 8-12

Hand-held programmer  
  features of, 11-7  
  GBC configuration, 8-8  
  modes of operation, 11-7

Hardware, load requirements, 12-12

Heat, dissipation calculations, H-1, M-1

Heat dissipation, calculating, 12-16, H-1

Help, from GE Fanuc, 13-8

HHP, 11-6  
  Cable data sheet, 10-34

High capacity AC/DC powersupply  
  illustration of, 4-4

- overvoltage protection devices, 2-24
  - specifications, 4-5
  - High capacity DC power supply, specifications, 4-14
  - High Capacity DC power supply (24 VDC), illustration of, 4-13
  - High speed counter, 8-24
  - Horner Electric, Inc., 11-9
  - Host CPU, 8-12
  - Hotline, PLC, 2-1
  - HSC, High Speed Counter, 8-24
- I**
- I/O bus expansion cable
    - description of, 10-23
    - I/O bus terminator plug requirements, 10-24
    - maximum cable distance, 10-24
    - maximum number in system, 10-24
  - I/O Bus Expansion cables
    - Application examples, 10-32
    - building, 10-23
    - wiring diagrams, 10-29
  - I/O bus termination information, 10-32
  - I/O cables for 32-point modules, 10-41
  - I/O expansion
    - bus termination, 3-13, 10-26
    - system connections, 10-32
  - I/O Expansion Bus cables, 3-12
  - I/O faceplate, J-3
  - I/O interface cables
    - for 32-point modules, 10-42, 10-49, 10-57
    - for Power Mate APM modules, 10-45
  - I/O link interface module, slave, 8-25
  - I/O link master module, 8-26
    - compatibility, 8-27
    - restart pushbutton, 8-27
    - serial port, 8-27
  - I/O Module, Relay protection, 7-5
  - I/O module, Figure, standard density, 7-4
  - I/O Modules
    - 32-point features, 7-6
    - 50-pin, 32-point figure, 7-7
    - Analog features, 7-10
    - Standard density, 7-3
    - Wire routing, 7-12
  - I/O modules
    - 32-point figure, 7-6
    - 32-point wiring figure, 7-8
    - basic types, 7-1
    - inserting a module, 2-3
    - installing a terminal board, 2-5
    - number in FIP Nest, 8-12
    - removing a module, 2-4
    - removing a terminal board, 2-6
    - Wiring 32-point modules, 7-8
    - wiring to modules, 2-18
  - I/O Processor Module, 8-28
  - I/O processor module
    - changing configuration parameters, 8-29
    - configuration
      - using Logicmaster 90 configurator, 8-28
      - using the hand-held programmer, 8-28
    - features, 8-29
    - threshold voltage, 8-29
    - watchdog timer circuit, 8-29
  - I/O terminal block
    - IC693ACC329, J-6
    - IC693ACC330, J-7
    - IC693ACC331, J-8
    - IC693ACC332, J-9
    - IC693ACC333, J-10
    - IC693ACC377, J-13
  - IBM-AT/XT serial port, C-6
  - IC640WMI310, WSI board, 11-2
  - IC640WMI320, WSI board, 11-2
  - IC647CBL704, Cable, WSI, 10-9
  - IC649AEA101, Obsolete Ethernet transceiver, L-2
  - IC649AEA102, Ethernet transceiver, 5-23, 8-30, 8-31, L-1
  - IC649AEA103, Ethernet transceiver, 5-23, 8-30, 8-31, L-2
  - IC655CCM590
    - isolated repeater/converter, E-1
    - obsolete repeater/converter, E-1
  - IC655CMM590, Obsolete repeater/converter, 11-10
  - IC690ACC900, RS-232 to RS-485 Converter, 11-4

- IC690ACC901, Miniconverter, 11-5
- IC690ACC903
  - port isolator, G-1
  - Port Isolator overview, 11-10
- IC690CBL701, Cable, programmer, 10-13
- IC690CBL702
  - Cable, programmer, 10-15
  - use on PCM modules, 8-33, 8-36
- IC690CBL705, Cable, programmer, 10-17
- IC690CBL714A
  - Cable, multidrop, 10-19
  - multidrop cable, K-2
- IC693ACC301, Memory backup battery, 6-1
- IC693ACC303, HHP memory card, 11-7
- IC693ACC308, baseplate adapter bracket, 2-8, 3-22
- IC693ACC308 Bracket, 19" rack mounting, 2-9, 3-23
- IC693ACC313 Bracket, recessed 19" rack mount, 2-10, 3-23
- IC693ACC315, Battery accessory kit, 6-8
- IC693ACC329, TBQC, J-6
- IC693ACC330, TBQC, J-7
- IC693ACC331, TBQC, J-8
- IC693ACC332, TBQC, J-9
- IC693ACC333, J-10
- IC693ACC377, TBQC, J-13
- IC693ADC311, Alphanumeric Coprocessor, 8-35
- IC693APU300, High Speed Counter, 8-24
- IC693APU301/302, Axis Positioning Module, 8-15
- IC693APU305, I/O Processor Module, 8-28
- IC693BEM320, I/O link, slave, 8-25
- IC693BEM321, I/O Link, master, 8-26
- IC693BEM330, FIP Remote I/O Scanner, 8-12
- IC693BEM331, Genius Bus Controller, 8-6
- IC693BEM340, FIP Bus Controller Module, 8-10
- IC693CBK002/003/004, cable kits for TBQC, 10-63
- IC693CBL300, Cable, I/O Bus Expansion, 10-23
- IC693CBL301, Cable, I/O Bus Expansion, 10-23
- IC693CBL302, Cable, I/O Bus Expansion, 10-23
- IC693CBL303, Data sheet, 10-34
- IC693CBL304, Wye cable, 10-36
- IC693CBL305
  - use on CMM module, 8-34
  - use on PCM modules, 8-33, 8-36
  - Wye cable, 10-36
- IC693CBL306, Cable, 32-point I/O, 10-39
- IC693CBL307, Cable, 32-point I/O, 10-39
- IC693CBL308, Cable, 32-point I/O, 10-41
- IC693CBL309, Cable, 32-point I/O, 10-41
- IC693CBL310, Cable, 32-point I/O, 10-42
- IC693CBL311
  - APM cable, 8-16
  - Cable, APMI/O, 10-45
- IC693CBL312, Cable, I/O Bus Expansion, 10-23
- IC693CBL313, Cable, I/O Bus Expansion, 10-23
- IC693CBL314
  - Cable, I/O Bus Expansion, 10-23
  - use with DSM302, 8-17
- IC693CBL315, Cable, 32-point I/O, 10-49
- IC693CBL316
  - use on Ethernet module, 8-31
  - use with DSM314, 8-20
- IC693CBL317
  - APM cable, 8-16
  - Cable, APMI/O, 10-45
- IC693CBL319
  - APM cable, 8-16
  - Cable, APMI/O, 10-45
- IC693CBL320
  - APM cable, 8-16
  - Cable, APMI/O, 10-45
- IC693CBL321, Cable, 32-point I/O, 10-54
- IC693CBL322, Cable, 32-point I/O, 10-54
- IC693CBL323, Cable, 32-point I/O, 10-54
- IC693CBL327, Cable, 32-point I/O, 10-57
- IC693CBL328, Cable, 32-point I/O, 10-57

# Index

---

- IC693CBL329, Data sheet, 10-62
- IC693CBL330, Data sheet, 10-62
- IC693CBL331, Data sheet, 10-62
- IC693CBL332, Data sheet, 10-62
- IC693CBL333, Data sheet, 10-62
- IC693CBL334, Data sheet, 10-62
- IC693CBL340/341, Cable, PTM interface, 10-65
- IC693CHS392, figure, 3-9
- IC693CHS393
  - figure, 3-11
  - remote baseplate, 3-11
- IC693CHS398, figure, 3-8
- IC693CHS399, figure, 3-10
- IC693CMM302, Genius Comm. Module+, 8-4
- IC693CMM311, Comm. Coprocessor, 8-34
- IC693CMM321, Ethernet Interface module, 8-30
- IC693CPU311
  - Data sheet, 5-25
  - figure, 3-5
- IC693CPU313, Data sheet, 5-26
- IC693CPU313 figure, 3-5
- IC693CPU323
  - Data Sheet, 5-27
  - figure, 3-5
- IC693CPU331, Data sheet, 5-28
- IC693CPU340, Data sheet, 5-29
- IC693CPU341, Data sheet, 5-30
- IC693CPU350
  - Data sheet, 5-31
  - Hardware features, 5-18
- IC693CPU351
  - Data sheet, 5-32
  - Hardware features, 5-19
- IC693CPU352
  - Data sheet, 5-33
  - Hardware features, 5-19
- IC693CPU360
  - Data sheet, 5-34
  - Hardware features, 5-18
- IC693CPU363
  - Data sheet, 5-35
  - Hardware features, 5-19
- IC693CPU364
  - Data sheet, 5-36
  - Hardware features, 5-22
- IC693CSE311, Data sheet, 9-14
- IC693CSE311 baseplate, drawing, 9-9
- IC693CSE313, Data sheet, 9-15
- IC693CSE313 baseplate, drawing, 9-9
- IC693CSE323, Data sheet, 9-16
- IC693CSE323 baseplate, drawing, 9-9
- IC693CSE331
  - Data sheet, 9-17
  - drawing, 9-10
  - State Logic CPU, 9-10
- IC693CSE340
  - Data sheet, 9-18
  - drawing, 9-10
  - State Logic CPU, 9-10
- IC693DSM302
  - Digital Servo Module, 8-17
  - module drawing, 8-17
- IC693DSM314
  - Digital Servo Module, 8-20
  - module drawing, 8-20
- IC693DVM300
  - connections, 7-16
  - module drawing, 7-14
  - specifications table, 7-15
  - valve driver module, 7-14
- IC693GCM301, Genius Comm. Module, 8-2
- IC693PCM300/301/311Prog. Coprocessor, 8-32
- IC693PRG300, Hand-Held Programmer, 11-6
- IC693PTM100/101, Power Transducer, 8-40
- IC693PWR321, power supply, 4-2
- IC693PWR322, power supply, 4-7
- IC693PWR328, power supply, 4-10
- IC693PWR330, power supply, 4-4
- IC693PWR331, power supply, 4-13
- IC693SLP300, module drawing, 9-4
- IC693TCM302, Temperature Control Module, 8-37
- IC693TCM302/303, module drawing, 8-37

Illustration of the DSM302 Module, 8-18, 8-21

Indicator lights  
relating to I/O terminals, 13-1  
see LED indicators also, 13-2

Inspection, new system, 2-1

## Installation

32-P oint modules, 2-20  
baseplate adapter bracket, 2-8, 3-22  
baseplate, model 311/313, 3-18  
baseplate, model 323, 3-19  
Basic procedure, 2-28  
grounding procedures, 2-11  
I/Oexpansion system, 10-32  
load requirements for components, 12-12  
multidrop configuration, 10-10  
pcm to programmer cables, 10-14, 10-16, 10-18  
remote expansion system, 3-17, 10-33

Installing I/O Module Term Board, 2-5

Instructions for floating neutral (IT) systems, 2-25

Internet, GE Fanuc site, 13-8

Interposing terminal blocks, 2-19, J-2, J-11

Isolated Repeater/Conv., overview (obsolete), 11-10

Isolated repeater/converter, 11-4

cable diagrams, E-7  
complex multidrop configuration, E-6  
description of, E-1  
illustration of, E-2  
logic diagram, E-3  
pin assignments, E-4  
rules for using, E-6  
simple multidrop configuration, E-6  
system configurations, E-5

## J

Jumper strap for overvoltage protection devices, 4-6, 4-18

Jumpers for EPROM/EEPROM selection, 5-8

Jumpers, converter board, D-7  
configuration of, D-8

## K

Key, CPU, replacement, 5-16, 13-6

Keypad, CPU, 5-15

Kits, spare parts, mechanical, 13-6

## L

Layout PLC system, good layout benefits, 12-17

Layout, PLC, figure, 12-20

Layout, PLC system, guidelines, 12-17

## LED indicators

CPU, 13-2  
Input modules, 13-2  
Option modules, 13-2  
Output modules, 13-2  
P1 (CPU 351/352), 5-20  
P2 (CPU 351/352), 5-20  
power supplies, 4-17  
relating to terminal board, 13-1  
SNP (CPU 351/352), 5-20

LEDs, 8-11, 8-31

List of fuses, 13-5

Lithium battery, 4-20

Load capacity, power supply, 12-12

## Load requirements

hardware, 12-12  
sample calculations, 12-15  
table of, 12-13

Local expansion system, example, point-to-point wiring, 10-29

## Location

of modules in racks, 12-18  
rack, 12-17

Logicmaster 90-30 Configuration Software, 8-19, 8-22

Low battery warning, 4-21, 6-1

## M

Machine references (% symbol), 5-11

Maintenance, preventive, table, 13-7

Making a 100% shielded cable, 10-28

Math, Floating point feature, 5-15

- Maximum number of modules per system, 12-11
  - Mechanical spare parts kits, 13-6
  - Megabasic, 8-32
  - Memory
    - Comparing PROM devices, 5-9
    - Configurable, 5-14
    - CPU table, 5-11
    - Flash, 5-10, 5-15
    - Flash, protection, 5-15
    - Maintaining during storage, 6-7
    - PROM types, 5-5
    - Protection strategy, 6-3
    - RAM, 5-5
    - User options, 5-8
    - Volatility, 5-4
  - Memory card, HHP, 11-7
  - Microprocessor types, CPU, 5-3
  - Miniconverter kit
    - cable diagrams, F-3
    - IC690ACC901, 11-5
    - RS-232 port pin assignments, F-1
    - RS-422 port pin assignments, F-2
    - RS-422 (SNP) to RS-232, F-1
    - specifications, F-4
    - system configurations, F-2
  - Model 331, jumpers for EPROM/EEPROM, 5-8
  - Module
    - fuse list, 13-5
    - location, 12-18
  - Module count, 12-7
    - maximum table, 12-11
  - Module features figure, 2-2
  - Module load requirements, table, 12-13
  - Module location
    - Defined, 3-3
    - figure, 12-19
  - Module location in baseplate, number of, valid, 12-11
  - Modules, replacing, 13-4
  - Motion Mate APM300, 8-15
    - Axis Positioning Module, 8-15
  - Motion Mate DSM
    - DSM302, 8-17
    - DSM314, 8-20
  - Motion Mate DSM302, Illustration of, 8-18, 8-21
  - Mounting, Baseplates, 2-8
  - Multidrop
    - configuring, K-5
    - system limitations, K-2
  - Multidrop cables
    - specification table, K-2
    - types, K-2
  - Multidrop configuration, 10-12
    - with converter, 10-10
    - with isolated repeater/converter, E-6
  - Multidrop connections, C-11
  - Multidrop, SNP
    - connecting, K-6
    - examples, K-4
    - overview, K-1
    - setting SNP ID, K-5
    - troubleshooting, K-6
    - wiring diagram, K-3
  - Multiple hosts, Genius, 8-6
- ## N
- Nickname, Compared to address, 5-11
- ## O
- Operation without battery, 6-6
  - Operator interface terminal, 8-35
  - Option module, list, 8-1
  - Option modules
    - alphanumeric display coprocessor, 8-35
    - Comm. Coprocessor, 8-34
    - DSM302, 8-17
    - DSM314, 8-20
    - enhanced genius communications, 8-4
    - Ethernet interface, 8-30
    - FIP bus controller, 8-10
    - FIP remote I/O scanner, 8-12
    - Genius bus controller, 8-6
    - Genius communications, 8-2
    - high speed counter, 8-24
    - I/O link interface, slave, 8-25
    - I/O link master, 8-26
    - I/O processor, 8-28
    - Motion Mate APM300, 8-15
    - personal computer interface card, 11-8

Power Transducer, 8-40  
programmable coprocessor modules,  
8-32  
state logic processor, 9-5  
Temperature Control (TCM), 8-37  
Output module fuses, 13-5  
Overvoltage protection devices, 4-5, 4-17  
jumper strap installation, 2-24

## P

Parts kits, mechanical, spare, 13-6  
PCIF/PCIF2, description, 11-8  
PCM, Wye cable, 10-36  
Personal Computer Interface, Data sheet,  
11-8  
Planning your system, 12-1  
PLC, mounting orientation, 12-21  
PLC Basics, 1-1  
PLC customer service, 2-1  
PLC hotline, 2-1  
PLC mounting, mounting orientation,  
12-21  
Point-to-point RS-232 connections, C-7  
Point-to-point RS-422 connections, C-10  
Port, 8-11  
Port expansion, Cables for PCM, ADC,  
CMM, 10-36  
Port expansion cable, 10-36  
Port Isolator  
IC690ACC903, G-1  
overview, 11-10  
Port, serial, CPU351, 352, 353, 5-21  
Port, serial, Series 90, C-3  
Ports, ethernet interface  
AAUI, 8-31  
firmware upgrade, 8-31  
serial, ethernet interface, 8-31  
station manager port, 8-31  
Posts, terminal board, 2-7  
Power Supply, DC input only, 4-7  
Power supply  
+24 vdc output connections, 2-27  
24/48 VDC input, 4-7  
48 VDC input, 4-10  
ac power source connections, 2-23  
AC/DC input, 4-2  
Backup battery, location, 4-20  
comparison table, 12-7  
Feature comparison, 4-1  
field wiring to DC input supply, 4-16  
field wiring to standard AC/DC supply,  
2-23, 4-5  
high capacity 120/240 VAC or 125 VDC,  
4-4  
high capacity 24 VDC input, 4-13  
isolated +24 vdc supply connections,  
4-6, 4-16  
load calculation, 12-12  
load capacity, 12-12  
load ratings, 3-21  
location in baseplate, 4-2  
mounting orientation, 3-21  
serial port connector, location of, 4-20,  
5-3, 9-10  
standard 120/240 VAC or 125 VDC, 4-2  
temperature, 3-21, 12-21  
Power supply capacities  
dc supply, 4-7, 4-10, 4-13  
high capacity AC/DC supply, 4-4  
standard AC/DC supply, 4-2  
Power supply output voltages, 4-18  
Power supply rating, affect of mounting  
position, 12-21  
Power Supply slot, 3-3  
Power supply specifications  
dc supply, 4-8, 4-11  
high capacity ac/dc supply, 4-5  
high capacity dc supply, 4-14  
standard ac/dc supply, 4-3  
Power Transducer, IC693PTM100/101, 8-40  
Powering down, Expansion and remote  
racks, 3-14  
Preinstallation check, 2-1  
Preventive maintenance, table, 13-7  
Product support  
customer service, 2-1  
technical help, 2-1  
Program compatibility, 5-12  
Programmable coprocessor modules, 8-32  
Programmer, Hand-Held, IC693PRG300,  
11-6

- PROM
    - Configuration table, 5-6
    - Types, 5-5
    - Use in Series 90–30, 5-5
  - PROM option, EPROM/EEPROM selection, model 331, 5-8
  - Protection devices, overvoltage, 2-24, 4-5, 4-17
  - Protocol
    - CMM, 8-34
    - RTU (Modbus), 8-34
    - SNP, 8-34
  - PTM, Power Transducer, 8-40
  - Publication, cross-reference, I-1
- Q**
- Quick connect terminal block, J-2
- R**
- Rack, Definition, 3-3
  - Rack number, Selection switch, 3-14
  - RAM, Memory, 5-5
  - RAM memory backup battery, 4-20, 6-1
  - Reference types, user, 5-11
  - References, not used, 8-7
  - Relay output module, Protection, 7-5
  - Remote, baseplates, 3-10
  - Remote baseplate
    - 10-slot, 3-11
    - Defined, 3-3
    - IC693CHS399, 3-10
  - Remote baseplates, Features, 3-10
  - Remote drops, 8-6, 8-10
  - Remote expansion system
    - connections, 3-17, 10-33
    - example of using wye cables, 10-31
    - example, point-to-point wiring, applications requiring less noise immunity, 10-29
    - wye cable wiring diagram, earlier version baseplates, 10-30
  - Remote I/O scanner, FIP
    - description of, 8-12
    - features of, 8-12
  - Repeater/converter isolated, 11-4
    - cable diagrams, E-7
    - complex multidrop configuration, E-6
    - description of, E-1
    - illustration of, E-2
    - logic diagram, E-3
    - pin assignments, E-4
    - rules for using, E-6
    - simple multidrop configuration, E-6
    - system configurations, E-5
  - Replacing modules, 13-4
  - Restart pushbutton
    - alphanumeric display coprocessor, 8-35
    - communications control, 8-34
    - ethernet interface, 8-31
    - I/O link master, 8-27
  - RS-232 point-to-point connections, C-7
  - RS-232/RS-485 converter, C-7
  - RS-422 point-to-point connections, C-10
  - RS-422/RS-485 to RS-232 converter
    - cable description, D-3
    - features, D-1
    - functions, D-1
    - installation procedures, D-2
    - jumper configuration, user options, D-7
    - location in system, D-1
    - logic diagram, D-6
    - RS-232 interface pin assignments, D-4
    - RS-422/RS-485 interface assignments, D-5
  - RS-485 compatible serial port, 4-20, 5-3
  - RS-232, converter, obsolete, 11-4
  - RS-422
    - cable specs., C-2
    - pin-out, C-4
    - Serial interface, C-1
  - RS-485, converter, obsolete, 11-4
  - RTU (Modbus) communications protocol, 8-34
  - RTU master protocol, PCM module, 8-32
- S**
- Scan time, factors affecting, 12-16
  - SCM, State Logic Serial Module, 9-2
  - Sequential Event Recorder, 5-16
  - SER, 5-16
    - instruction, 13-4

- Serial number
  - Baseplates, 3-2
  - Ethernet interface module, 8-31
  - locating on modules, 2-2
- Serial numbers, recording, 2-1
- Serial Port, ethernet interface, 8-31
- Serial port, 8-11
  - 351 connectors, 5-20
  - 352 connectors, 5-20
  - 363 connectors, 5-20
  - I/O link master module, 8-27
  - IBM-AT/XTC-6
  - LED indicators, 5-20
  - pin-out, IBM-AT/XTC-6
  - pin-out, Workmaster, C-5
  - Series 90, C-3
  - Workmaster, C-5
- Serial port and cables, workmaster serial port, C-5
- Serial port and cables, appendix C
  - cable and connector specifications, C-2
  - IBM-AT/XTserial port, C-6
  - multidrop connections, C-11
  - RS-232 point-to-point connections, C-7
  - RS-232/RS-485converter, C-7
  - RS-422 interface, C-1
  - RS-422 point-to-point connection, C-10
  - serial cable diagrams, C-7
- Serial port connector
  - location of, 9-10
  - on power supply, 4-20, 5-3
  - when functional, 4-20, 5-4, 9-11
- Serial Port Pin Assignments, CPU351, 352, 363, 5-21
- Serial ports, CPU, 5-15
- Series 90–30, 48 VDC supply, 4-10
- Series 90–30 PLC
  - backplane, 3-14
  - baseplate installation, 3-18
  - CPU capacities, 5-10
  - recording serial numbers, 2-1
  - user references, 5-11
  - visual inspection of new system, 2-1
- Series 90-30
  - 125 vdc supply, 4-2, 4-4
  - 24/48VDCsupply, 4-7
  - high capacity 24 VDC supply, 4-13
  - high capacity ac/dc supply, 4-4
  - power supplies, 4-2, 4-4
  - standardac/dcsupply, 4-2
- Series Six PLC, 8-7
- Shield ground, CPU351, 352 figure, 2-14
- Shield grounding
  - CPUs 351 and 352, 2-14
  - CPUs 363 and 364, 2-15
  - general information, 2-14
- Shield treatment, cables, 10-27
- Shielded cable, making a, 10-28
- Slot number, Defined, 3-3
- SLP, State Logic Processor, 9-4
- SNP communications protocol, 8-34
- SNP ID, for multidrop, K-5
- SNP multidrop, overview, K-1
- SNP port connection, 4-20, 5-3
- Software, Configuration, 8-19, 8-22
- Spare parts, kits, 13-6
- Spare parts kits, mechanical, 13-6
- Specifications
  - 24 vdc high capacity power supply, 4-14
  - 24/48 vdc power supply, 4-8
  - 48 vdc power supply, 4-11
  - high capacity ac/dc power supply, 4-5
  - IC690ACC900 converter, D-9
  - serial port cables, C-2
  - standard ac/dc power supply, 4-3
- SQE, Ethernet products, L-1, L-2
- Standard AC/DC powersupply
  - ac power source connections, 4-5
  - dc power source connections, 4-5
  - illustration of, 4-2
  - overvoltage protection devices, 4-5, 4-17
  - specifications, 4-3
- Standard serial COM port, 11-4
- State Logic
  - CPU table, 9-12
  - CPUs, 9-8
  - Processor module (SLP), 9-4
  - product listing, 9-1
  - Serial Comm. module, 9-2
- Sweep time
  - factors, 12-16
  - factors affecting, 12-16
- Symbol, %, use of, 5-11
- System design
  - baseplate selection, 12-6

- CPU selection, 12-4
- I/O requirements, 12-1
- Option module requirements, 12-2
- power supply selection, 12-6

## T

- Tables and formulas, M-1
- TBQC
  - cables and kits, 10-63
  - for 32-point modules, J-11
- TCM, Temperature Control Module, 8-37
- TCM comparison table, 8-39
- Technical support telephone number, 2-1
- Telephone numbers, GE Fanuc help, 13-8
- Terminal Block Quick Connect, J-1
  - 32-point cables, J-12
  - cables, J-3
  - I/O face plate, J-3
  - installation, J-3
  - terminal blocks, J-2, J-11
- Terminal block quick connect assembly,
  - for 16-Point modules, 2-19
- Terminal blocks, interposing, J-2, J-11
- Terminal board
  - connecting to, 2-18
  - Installing, 2-5
  - posts, 2-7
  - Removing, 2-6
  - With holding screws, 2-7
- Termination, I/O bus, 10-32
- Terms, glossary of, A-1
- Third-party modules, 8-1
- Time of day clock, Accuracy, 5-12
- Timing diagram, 4-19
- Troubleshooting
  - features of hardware, 13-1
  - multidrop problems, K-6
  - using software, 13-3

## U

- Upgrading, CPU firmware, 5-6
- User PROM option, EPROM/EEPROM selection, model 331, 5-8

- User references
  - description of, 5-11
  - range and size, models 311-341, 5-11
  - types of, 5-11

## V

- Version, CPU firmware, 5-7
- Visual inspection of new system, 2-1
- Volatility, Memory, 5-4

## W

- Warranty claims, 2-1
- Web site, GE Fanuc, 7-2, 8-1, 13-8
- Weidmuller, 912263 terminal block, 2-19
- Wire routing, I/O Modules, 7-12
- Wire size, power supply wiring, 2-23
- Wiring
  - Color coding, 2-17
  - General guidelines, 2-17
  - I/O module routing, 7-12
  - I/O modules, 2-18
  - Power supplies, 2-23
  - Routing wires, 2-17
- Wiring methods
  - 32-point modules, 7-8
  - Analog I/O modules, 2-21, 7-11
  - Standard density I/O modules, 7-5
- Work station interface, board, 11-2
- Workmaster computers
  - replacing, 11-3
  - WSI board, 11-3
- Workmaster serial port, C-5
- WSI, board, 11-2
- WYE cable, 8-34
  - connection to PCM modules, 10-14, 10-16, 10-18
  - wiring diagram, 10-36
  - wiring diagram for current remote baseplates, 10-31
  - wiring diagram for earlier version baseplates, 10-30
  - wiring diagram, remote system, 10-31
  - wiring diagram, remote system (for earlier version baseplates), 10-30