



efesotomasyon.com

GE Fanuc Automation

Programmable Control Products

Series 90TM -30 PLC I/O Module Specifications

GFK-0898F

July 2000

Warnings, Cautions, and Notes as Used in this Publication

Warning

Warning notices are used in this publication to emphasize that hazardous voltages, currents, temperatures, or other conditions that could cause personal injury exist in this equipment or may be associated with its use.

In situations where inattention could cause either personal injury or damage to equipment, a Warning notice is used.

Caution

Caution notices are used where equipment might be damaged if care is not taken.

Note

Notes merely call attention to information that is especially significant to understanding and operating the equipment.

This document is based on information available at the time of its publication. While efforts have been made to be accurate, the information contained herein does not purport to cover all details or variations in hardware or software, nor to provide for every possible contingency in connection with installation, operation, or maintenance. Features may be described herein which are not present in all hardware and software systems. GE Fanuc Automation assumes no obligation of notice to holders of this document with respect to changes subsequently made.

GE Fanuc Automation makes no representation or warranty, expressed, implied, or statutory with respect to, and assumes no responsibility for the accuracy, completeness, sufficiency, or usefulness of the information contained herein. No warranties of merchantability or fitness for purpose shall apply.

The following are trademarks of GE Fanuc Automation North America, Inc.

Alarm Master	Genius	ProLoop	Series Three
CIMPLICITY	Helpmate	PROMACRO	VersaMax
CIMPLICITY 90-ADS	Logicmaster	Series Five	VersaPro
CIMSTAR	Modelmaster	Series 90	VuMaster
Field Control	Motion Mate	Series One	Workmaster
GENet	PowerTRAC	Series Six	

RFI Standards

The Series 90™-30 PLC and its associated modules have been tested and found to meet or exceed the requirements of FCC Rule, Part 15, Subpart J. The Federal Communications Commission (FCC) requires the following note to be published.

NOTE

This equipment generates, uses, and can radiate radio frequency energy and if not installed in accordance with this instruction manual, may cause harmful interference to radio communications. It has been tested and found to comply with the limits for a Class A digital device pursuant to Part 15 of the FCC Rules, which are designed to provide reasonable protection against harmful interference when operated in a commercial environment. Operation of this equipment in a residential area is likely to cause harmful interference, in which case the user will be required to correct the interference at his own expense.

The following note is required to be published by the Canadian Department of Communications.

NOTE

This digital apparatus does not exceed the Class A limits for radio noise emissions from digital apparatus set out in the radio interference regulations of the Canadian Department of Communications.

Preface

The following statements are required to appear in the *Series 90-30 Installation Manual* and the *Series 90™-30 I/O Specifications Manual* for Class I Div 2 Hazardous Locations.

1. EQUIPMENT LABELED WITH REFERENCE TO CLASS I, GROUPS A, B, C, and D, DIV. 2 HAZARDOUS LOCATIONS IS SUITABLE FOR USE IN CLASS I, DIVISION 2, GROUPS A, B, C, D OR NON-HAZARDOUS LOCATIONS ONLY.
2. **WARNING - EXPLOSION HAZARD - SUBSTITUTION OF COMPONENTS MAY IMPAIR SUITABILITY FOR CLASS I, DIVISION 2.**
3. **WARNING - EXPLOSION HAZARD - DO NOT DISCONNECT EQUIPMENT UNLESS POWER HAS BEEN SWITCHED OFF OR THE AREA IS KNOWN TO BE NON-HAZARDOUS.**
4. ALL UNUSED SLOTS IN ALL BASEPLATES MUST BE POPULATED WITH FILLER MODULES, IC693ACC310, OR EQUIVALENT.



Please Note the Following Important Information



The I/O modules described in this manual can be controlled in two different ways:

1. With a Series 90-30 Programmable Logic Controller (PLC).
2. By a Personal Computer (PC) that has a Personal Computer Interface card.

If you are using Series 90-30 I/O as part of a Series 90-30 PLC system, you should also refer to GFK-0356, the *Series 90-30 Programmable Controller Installation Manual*, which describes the hardware components and provides installation instructions for the Series 90-30 PLC.

If you are using a Personal Computer to control the Series 90-30 I/O, refer also to the documentation for the Personal Computer Interface card and the documentation for your Personal Computer.

Documentation of product agency approvals, standards, and general specifications is provided in a separate data sheet, GFK-0867. A copy of this data sheet is included as Appendix B in this manual; however, for the most current version of the data sheet, consult your authorized GE Fanuc PLC distributor or local GE Fanuc sales representative. It is also available on the GE Fanuc web site: www.gefanuc.com

Installation instructions in this manual are provided for installations that do not require special procedures for noisy or hazardous environments. For installations that must conform to more stringent requirements (such as CE Mark), see GFK-1179, *Installation Requirements for Conformance to Standards*.

Revisions to This Manual

Appropriate changes have been made to this manual (GFK-0898F) to add new or revised information. Additionally, corrections and enhancements have been made where necessary.

Following is a list of revisions to this manual as compared to the previous version (GFK-0898E).

- Chapter 1 (“Introduction to the Series 90–30 I/O System”) in the previous version has been divided into several chapters in this manual: Chapter 1 provides introductory information, Chapter 2 discusses installation, Chapter 3 documents Series 90–30 baseplates, and Chapter 4 documents Series 90–30 power supplies.
- Chapter 2 (“Discrete I/O Module Specifications”) in the previous version has been divided into four chapters in this manual: Chapter 5, “General Discrete I/O Module Information,” Chapter 6, “Discrete Input Modules,” Chapter 7, “Discrete Output Modules,” and Chapter 8, “Discrete Combination I/O Modules.”
- Chapter 3 (“Analog I/O Module Specifications”) in the previous version has been divided into four chapters in this manual: Chapter 9, “General Analog I/O Module Information,” Chapter 10, “Analog Input Modules,” Chapter 11, “Analog Output Modules,” and Chapter 12, “IC693ALG442 Analog Combination Module.”
- Chapter 13 (“Maintenance and Troubleshooting”) has been added.
- Appendix C includes information on additional cables.

Preface

- Appendix D – Information was added for the IC693ACC337 a TBQC (Terminal Block Quick Connect) terminal block for 32–point I/O modules. Also TBQC interface cable information has been added including a cross–reference to obsolete cables.
- Appendix F – This appendix was added to the manual. It discusses how to calculate heat dissipation for Series 90–30 PLC components.

Content of this Manual

Chapter 1. Introduction to the Series 90-30 I/O System: This chapter provides general information about the Series 90-30 I/O System and describes two ways that the Series 90-30 I/O can be controlled.

Chapter 2. General Installation Guidelines: Discusses installation subjects such as, mounting, wiring, and grounding Series 90–30 components.

Chapter 3. Series 90–30 Baseplates. Describes the various types of baseplates, gives dimension data, and describes how to interconnect baseplates.

Chapter 4. Series 90–30 Power Supplies. Provides data sheet type material for each Series 90–30 power supply.

Chapter 5. General Discrete I/O Module Information. Provides a list of all Series 90–30 discrete I/O modules and describes the various types. Discusses general discrete subjects such as the definition of positive and negative logic as applicable to these modules.

Chapter 6. Discrete Input Modules. Provides data sheet type material for these modules.

Chapter 7. Discrete Output Modules. Provides data sheet type material for these modules.

Chapter 8. Discrete Combination I/O Modules. Provides data sheet type material for these modules.

Chapter 9. General Analog I/O Module Information. Provides a list of all Series 90–30 analog modules. Discusses analog theory as applied to these modules. Includes a table specifying the maximum number of the various analog modules permitted per Series 90–30 system.

Chapter 10. Analog Input Modules. Provides data sheet type material for these modules.

Chapter 11. Analog Output Modules. Provides data sheet type material for these modules.

Chapter 12. IC693ALG442 Analog Combination I/O Module. Provides data sheet type material for this module.

Chapter 13. Maintenance and Troubleshooting. Discusses features of the Series 90–30 PLC useful for troubleshooting I/O modules, including module LED indicators and programming software features. Provides tables of replaceable fuses, spare parts, and preventive maintenance suggestions. Includes information on how obtain help and support from GE Fanuc.

Appendix A. Glossary of Analog Terms. This appendix explains some general terms relating to analog measurements.

Appendix B. GE Fanuc Product Agency Approvals, Standards, General Specifications This appendix describes the agency approvals, standards, and general specifications for the listed GE Fanuc products.

Appendix C. I/O Cable Data Sheets: This appendix provides data sheets for cables used in the I/O system.

Appendix D. Terminal Block Quick Connect. This appendix describes the Terminal Block Quick Connect system, which consists of an interposing terminal block, I/O faceplate, and cable. This assembly allows faster wiring of applicable discrete I/O modules.

Appendix E. Personal Computer Interface Cards. These cards mount in a personal computer and serve as the CPU replacement for a PLC system. This appendix gives an overview of the two PCIF cards sold by GE Fanuc.

Appendix F. Series 90–30 Heat Dissipation. Explains how to calculate the heat dissipated by Series 90–30 PLC components. These calculations are required for enclosure sizing considerations.

Related Publications:

For information on the Series 90-30 Programmable Logic Controller, other Series 90-30 modules, and related products refer to the following publications:

GFK-0255 - Series 90™ PCM and Support Software User's Manual
GFK-0256 - MegaBasic™ Programming Reference Manual
GFK-0293 - Series 90™-30 High Speed Counter User's Manual
GFK-0401 - Workmaster® II PLC Programming Unit Guide to Operation
GFK-0402 - Series 90™-30 and 90-20 PLC Hand-Held Programmer User's Manual
GFK-0412 - Genius® Communications Module User's Manual
GFK-0466 - Logicmaster 90™ Series 90™-30/20/Micro Programming Software User's Manual
GFK-0467 - Series 90™-30/20/Micro PLC CPU Instruction Set Reference Manual
GFK-0487 - Series 90™ PCM Development Software (PCOP) User's Manual
GFK-0499 - CIMPPLICITY® 90-ADS Alphanumeric Display System User's Manual
GFK-0582 - Series 90™ PLC Serial Communications User's Manual
GFK-0631 - Series 90™-30 I/O LINK Interface User's Manual
GFK-0641 - CIMPPLICITY® 90-ADS Alphanumeric Display System Reference Manual
GFK-0664 - Series 90™-30 PLC Axis Positioning Module Programmer's Manual
GFK-0685 - Series 90™ Programmable Controllers Flow Computer User's Manual
GFK-0695 - Series 90™-30 Enhanced Genius® Communications Module User's Manual
GFK-0726 - Series 90™-30 PLC State Logic Processor User's Guide
GFK-0732 - Series 90™-30 PLC ECLiPS User's Manual
GFK-0747 - Series 90™-30 PLC OnTOP User's Guide
GFK-0750 - OnTop for Series 90™-30 (State Logic) Program User's Manual
GFK-0781 - Motion Mate™ APM300 for Series 90™-30 PLC Follower Mode User's Manual
GFK-0823 - Series 90™-30 I/O LINK Master Module User's Manual
GFK-0828 - Series 90™-30 Diagnostic System User's Manual
GFK-0840 - Motion Mate™ APM300 for Series 90™-30 PLC Standard Mode User's Manual
GFK-1028 - Series 90™-30 I/O Processor Module User's Manual
GFK-1034 - Series 90™-30 Genius® Bus Controller User's Manual
GFK-1037 - Series 90™-30 FIP Remote I/O Scanner User's Manual
GFK-1056 - Series 90™-30 State Logic Control System User's Manual
GFK-1084 - Series 90™-30 TCP/IP Ethernet Communications User's Manual
GFK-1186 - TCP/IP Ethernet Communications for the Series 90™ -30 PLC Station Manager Manual
GFK-1179 - Series 90™ PLC Installation Requirements for Conformance to Standards
GFK-1464 - Motion Mate™ DSM302 for Series 90™ -30 PLCs User's Manual
GFK-1466 - Temperature Control Module for the Series 90™ -30 PLC User's Manual
GFK-1742 - Motion Mate™ DSM314 for Series 90™ -30 PLCs User's Manual

Chapter 1 – Introduction to the Series 90-30 I/O System	1-1
Series 90-30 System	1-1
Series 90-30 I/O Module Types	1-1
Option Modules	1-3
Horner Electric and Third Party Modules	1-4
Chapter 2 – General Installation Guidelines	2-1
Receiving your Products – Visual Inspection	2-1
Pre-installation Check	2-1
Warranty Claims	2-1
System Layout Guidelines	2-2
Series 90-30 PLC Layout Example	2-3
Working with Series 90-30 Modules	2-4
Baseplate Installation and Mounting	2-10
Mounting a Baseplate to a Panel	2-10
Mounting a Baseplate to a 19” Rack	2-10
Grounding Procedures	2-13
System Grounding Procedures	2-13
Series 90-30 PLC Equipment Grounding	2-14
Module Shield Grounding	2-16
General Wiring Guidelines	2-17
Discrete I/O Module Connection Methods	2-18
Connections to I/O Module Terminal Boards	2-18
Terminal Block Quick Connect Installation for 16-Point Discrete Modules ...	2-19
Installation of 32-Point (50-Pin Connector) Discrete Modules	2-19
Installation of 32-Point (Dual 24-Pin Connector) Discrete Modules	2-21
Terminal Block Selection Guide for Discrete I/O Modules	2-22
General Wiring Methods for Analog Modules	2-25
General Analog Input Wiring Methods	2-25
Analog Input Module Wiring Methods for Noise Suppression	2-26
Shielding for Analog Input Modules	2-26
Wiring Diagrams for Current Transducers	2-31
Analog Output Module Wiring	2-34
Analog Output Shield Grounding Example One	2-35
AC Power Source Connections	2-38
Special Installation Instructions for Floating Neutral (IT) Systems	2-40
Definition of Floating Neutral Systems	2-40
Use These Special Installation Instructions for Floating Neutral Systems ...	2-41
DC Power Source Connections	2-42
Basic Installation Procedure	2-43
Chapter 3 – Series 90–30 Baseplates	3-1
Baseplate Types	3-1
Baseplate Terms Explained	3-3
CPU Baseplates	3-4
Expansion Baseplates (Figures 3-6 and 3-7)	3-8
Remote Baseplates (Figures 3-8 and 3-9)	3-10
Expansion Rack Connection Example	3-16
Expansion and Remote Baseplates Connection Example	3-17
Baseplate Mounting Dimensions	3-18

Contents

Load Ratings, Temperature, and Mounting Position	3-21
Baseplate Adapter Brackets for 19" Rack Mounting	3-22
Chapter 4 – Series 90–30 Power Supplies	4-1
Power Supply Categories	4-1
Power Supply Feature Comparison	4-1
AC/DC Input Power Supplies	4-2
IC693PWR321 Standard Power Supply, 120/240 VAC or 125 VDC Input	4-2
IC693PWR330 High Capacity Power Supply, 120/240 VAC/125 VDC Input ..	4-4
Field Wiring Connections for the AC/DC Input Power Supplies	4-5
DC Input Only Power Supplies	4-7
Calculating Input Power Requirements for IC693PWR322	4-8
Calculating Input Power Requirements for IC693PWR328	4-11
IC693PWR331 High Capacity Power Supply, 24 VDC Input	4-13
Calculating Input Power Requirements for IC693PWR331	4-15
IC693PWR332 High Capacity Power Supply, 12 VDC Input	4-16
Calculating Input Power Requirements for IC693PWR332	4-18
Field Wiring Connections to the DC Input-Only Power Supplies	4-19
Common Series 90-30 Power Supply Features	4-20
Output Voltage Connections to Backplane (All Supplies)	4-21
Calculating Power Supply Loading	4-25
Chapter 5 – General Discrete I/O Module Information	5-1
I/O Module Specifications	5-1
Discrete I/O Modules	5-3
Definition of Positive and Negative Logic	5-7
Positive Logic - Input Modules	5-7
Positive Logic - Output Modules	5-7
Negative Logic - Input Modules	5-8
Negative Logic - Output Modules	5-8
Chapter 6 – Discrete Input Modules	6-1
120 Volt AC Isolated Input, 8 Point	
IC693MDL230	6-1
IC693MDL230 Input Module Field Wiring Information	6-2
240 Volt AC Isolated Input, 8 Point	
IC693MDL231	6-3
IC693MDL231 Input Module Field Wiring Information	6-4
120 Volt AC Input, 16 Point	
IC693MDL240	6-5
IC693MDL240 Input Module Field Wiring Information	6-6
24 Volt AC/DC Positive/Negative Logic Input, 16 Point	
IC693MDL241	6-7
IC693MDL241 Input Module Field Wiring Information	6-8
125 Volt DC Positive/Negative Logic Input, 8 Point	
IC693MDL632	6-9
IC693MDL632 Input Module Field Wiring Information	6-10
24 Volt DC Positive/Negative Logic Input, 8 Point	
IC693MDL634	6-11
IC693MDL634 Input Module Field Wiring Information	6-12
24 Volt DC Positive/Negative Logic Input, 16 Point	
IC693MDL645	6-13

IC693MDL645 Input Module Field Wiring Information	6-14
24 Volt DC Positive/Negative Logic Input, 16 Point	
IC693MDL646	6-15
IC693MDL646 Input Module Field Wiring Information	6-16
Input Simulator, 8/16 Point	
IC693ACC300	6-17
24 VDC Positive/Negative Logic, 32 Point Input	
IC693MDL653	6-19
IC693MDL653 Input Module Field Wiring Information	6-20
5/12 VDC (TTL) Positive/Negative Logic, 32 Point Input	
IC693MDL654	6-21
IC693MDL654 Input Module Field Wiring Information	6-23
24 VDC Positive/Negative Logic, 32 Point Input	
IC693MDL655	6-26
IC693MDL655 Input Module Field Wiring Information	6-28
Chapter 7 – Discrete Output Modules	7-1
IC693DVM300 5VDC Input/24VDC Output Digital Valve Driver Module ...	7-1
120 Volt AC Output - 0.5 Amp, 12 Point	
IC693MDL310	7-4
IC693MDL310 Output Module Field Wiring Information	7-5
120/240 Volt AC Output - 2 Amp, 8 Point	
IC693MDL330	7-6
IC693MDL330 Output Module Field Wiring Information	7-7
120 Volt AC Output - 0.5 Amp, 16 Point	
IC693MDL340	7-8
IC693MDL340 Output Module Field Wiring Information	7-9
120/240 Volt AC Isolated Output - 2 Amp, 5 Point	
IC693MDL390	7-10
IC693MDL390 Output Module Field Wiring Information	7-11
12/24 Volt DC Positive Logic Output - 2 Amp, 8 Point	
IC693MDL730	7-12
IC693MDL730 Output Module Field Wiring Information	7-13
12/24 Volt DC Negative Logic Output - 2 Amp, 8 Point	
IC693MDL731	7-15
IC693MDL731 Output Module Field Wiring Information	7-16
12/24 Volt DC Positive Logic Output - 0.5 Amp, 8 Point	
IC693MDL732	7-18
IC693MDL732 Output Module Field Wiring Information	7-19
12/24 Volt DC Negative Logic 0.5 Amp Output - 8 Point	
IC693MDL733	7-20
IC693MDL733 Output Module Field Wiring Information	7-21
125 Volt DC Positive/Negative Logic 1 Amp Output - 6 Point	
IC693MDL734	7-22
IC693MDL734 Output Module Field Wiring Information	7-23
12/24 Volt DC Positive Logic Output - 0.5 Amp, 16 Point	
IC693MDL740	7-24
IC693MDL740 Output Module Field Wiring Information	7-25
12/24 Volt DC Negative Logic 0.5 Amp Output - 16 Point	
IC693MDL741	7-26
IC693MDL741 Output Module Field Wiring Information	7-27
12/24 Volt DC Positive Logic ESCP Output - 1 Amp, 16 Point	
IC693MDL742	7-28
IC693MDL742 Output Module Field Wiring Information	7-29

Contents

Isolated Relay Output, N.O., 4 Amp - 8 Point IC693MDL930	7-30
IC693MDL930 Output Module Field Wiring Information	7-31
Isolated Relay Output, N.C. and Form C, 8 Amp - 8 Point IC693MDL931	7-33
IC693MDL931 Output Module Field Wiring Information	7-34
Relay Output, N.O., 2 Amp - 16 Point IC693MDL940	7-36
IC693MDL940 Output Module Field Wiring Information	7-37
12/24 Volt DC Negative Logic Output, 32 Point IC693MDL750	7-39
Field Wiring Information	7-40
12/24 Volt DC Positive Logic Output, 32 Point IC693MDL751	7-41
IC693MDL751 Output Module Field Wiring Information	7-42
5/24 Volt DC (TTL) Negative Logic Output, 32 Point IC693MDL752	7-43
IC693MDL752 Output Module Field Wiring Information	7-45
12/24 Volt DC, 0.5A Positive Logic Output, 32 Point IC693MDL753	7-49
IC693MDL753 Output Module Field Wiring Information	7-51
Chapter 8 – Discrete Combination I/O Modules	8-1
120 Volt AC Input, Relay Output, 8 Inputs/8 Outputs IC693MAR590	8-1
Field Wiring Information	8-3
24 Volt DC Input, Relay Output, 8 Inputs/8 Outputs IC693MDR390	8-5
Field Wiring Information	8-7
Chapter 9 – General Analog Module Information	9-1
Analog Module Features	9-2
Load Requirements for Analog I/O Modules	9-3
I/O Installation and Wiring	9-4
Analog Terminology	9-4
Hardware Description of Analog Modules	9-4
CPU Interface to Analog Modules	9-6
Placement of A/D and D/A Bits within the Data Tables	9-8
Stair Step Effect of Output	9-9
Scaling	9-10
Performance Measures	9-10
Analog Module Field Wiring	9-11
Maximum Number of Analog Modules per System	9-12
Chapter 10 – Analog Input Modules	10-1
Analog Voltage Input - 4 Channel IC693ALG220	10-1
Analog Voltage Input Block Diagram	10-3
IC693ALG220 Analog Input Module Field Wiring Information	10-4
Analog Current Input - 4 Channel IC693ALG221	10-5
IC693ALG221 Analog Current Input Block Diagram	10-7
IC693ALG221 Analog Input Module Field Wiring Information	10-8

Analog Voltage Input - 16 Channel	
IC693ALG222	10-9
Voltage Ranges and Input Modes	10-9
Power Requirements and LEDs	10-9
Location in System	10-9
References Used	10-9
CPU Interface to the IC693ALG 222 Analog Voltage Input Module	10-11
Placement of A/D Bits within the Data Tables	10-11
IC693ALG222 Analog Module Field Wiring Connections	10-13
Terminal Assignments	10-13
IC693ALG222 Analog Input Module Field Wiring Diagrams	10-14
IC693ALG222 Analog Voltage Input Block Diagram	10-16
IC693ALG222 Analog Input Module Configuration	10-17
IC693ALG222 Configuration Using Logicmaster Software	10-18
Configuring IC693ALG222 Using Hand-Held Programmer	10-22
Module Present	10-22
Selecting %AI Reference	10-23
Removing Module From Configuration	10-24
Selecting Module Mode	10-24
Saved Configurations	10-26
Analog Current Input - 16 Channel	
IC693ALG223	10-27
Current Ranges	10-27
Power Requirements and LEDs	10-27
Location in System	10-27
References Used	10-28
CPU Interface to the IC693ALG223 Analog Current Input Module	10-29
Placement of A/D Bits within the Data Tables	10-29
IC693ALG223 Configuration	10-30
Configuring IC693ALG223 Using Logicmaster Software	10-31
Configuring IC693ALG223 Using Hand-Held Programmer	10-35
Module Present	10-35
Selecting %AI Reference	10-36
Removing Module From Configuration	10-37
Saved Configurations	10-38
IC693ACC223 Analog Module Field Wiring Connections	10-39
Terminal Assignments	10-39
IC693ACC223 Analog Input Module Field Wiring Diagrams	10-40
IC693ACC223 Analog Current Input Block Diagram	10-42
Chapter 11 – Analog Output Modules	11-1
Analog Voltage Output - 2 Channel	
IC693ALG390	11-1
IC693ALG390 Analog Voltage Output Block Diagram	11-3
IC693ALG390 Analog Output Module Field Wiring Diagram	11-4
Analog Current Output - 2 Channel	
IC693ALG391	11-5
IC693ALG391 Analog Current Output Block Diagram	11-8
IC693ALG391 Analog Output Module Field Wiring Diagrams	11-9
Analog Current/Voltage Output - 8 Channel	
IC693ALG392	11-11
IC693ALG392 Current/Voltage Ranges and Output Modes	11-12

Contents

IC693ALG392 Field Wiring Connections	11-14
Configuring the IC693ALG392 Analog Output Module	11-20
Configuring IC693ALG392 Using Logicmaster Software	11-21
Other Configuration Considerations for IC693ALG392	11-23
Configuring IC693ALG392 with Hand-Held Programmer	11-25
IC693ALG392 Analog Current/Voltage Output Block Diagram	11-30
Chapter 12 – IC693ALG442 Analog Combination I/O Module	12-1
Analog Current/Voltage Combination Module	
4 Input/2 Output Channels - IC693ALG442	12-1
IC693ALG442 Input Modes and Current/Voltage Ranges	12-4
IC693ALG442 Output Modes and Current/Voltage Ranges	12-6
IC693ALG442 Analog Module Field Wiring Connections	12-9
IC693ALG442 Analog Combo Module Field Wiring Diagram	12-10
IC693ALG442 Analog Combo Module Block Diagram	12-11
Configuring the IC693ALG442 Analog Combo Module	12-12
Configuring IC693ALG442 Using Logicmaster Software	12-13
Other Configuration Considerations	12-14
IC693ALG442 Ramp Mode Operation	12-18
E2 COMMREQ for IC693ALG442	12-20
Configuring IC693ALG442 with Hand-Held Programmer	12-24
Module Present	12-24
Selecting %I Reference	12-24
Selecting %AI Reference	12-25
Selecting %AQ Reference	12-26
Removing Module From Configuration	12-26
Selecting Module Stop Mode	12-27
Selecting Input Channel Ranges	12-28
Selecting Low and High Alarm limits	12-29
Freeze Mode	12-29
Saved Configurations	12-30
Maintenance and Troubleshooting	13-1
Troubleshooting Features of Series 90-30 Hardware	13-1
Module LED Indicators	13-2
Troubleshooting Features of Programming Software	13-3
Replacing Modules	13-5
Series 90-30 Product Repair	13-5
Module Fuse List	13-6
Spare/Replacement Parts	13-7
Preventive Maintenance Suggestions	13-8
Getting Additional Help and Information	13-9
Appendix A – Glossary of Analog Terms	A-1
Appendix B – GE Fanuc Product Agency Approvals, Standards	B-1
Appendix C – I/O Cable Data Sheets	C-1
IC693CBL300/301/302/312/313/314	
I/O Bus Expansion Cables	C-2
Building Custom Length I/O Bus Expansion Cables	C-4
IC693CBL306/307	
Extension Cables (50-Pin) for 32 Point Modules	C-13

IC693CBL308/309 I/O Cables (50-Pin) for 32 Point Modules	C-15
IC693CBL310 I/O Interface Cable (24-Pin) for 32 Point Modules	C-16
IC693CBL315 I/O Interface Cable (24-Pin) for 32 Point Modules	C-19
IC693CBL321/322/323 I/O Faceplate Connector to Terminal Block Connector, 24-Pin	C-23
IC693CBL327/328 I/O Interface Cables with Right Angle 24-Pin Connector	C-26
IC693CBL329/330/331/332/333/334 Cables 24-Pin I/O Faceplate Connector to Terminal Block Connector	C-31
Appendix D – Terminal Block Quick Connect Components	D-1
TBQC Components for 16-Point Modules	D-2
Terminal Blocks	D-2
Cable Current Rating	D-2
Cable Selection and Cross-Reference for 16–Point Modules	D-3
IC693ACC334 I/O Face Plate for 16-Point Modules	D-3
I/O Face Plate Installation	D-3
Module Wiring Information	D-4
Cable Information	D-4
Faceplate Connector Pin–Out (for 16–Point Modules)	D-5
Terminal Block Information	D-5
TBQC Components for 32-Point, Dual–Connector Modules	D-11
Terminal Block	D-11
Cable Selection and Cross-Reference for 32–Point Modules	D-12
Cable Current Rating	D-12
Module and Cable Data	D-12
Terminal Block Data	D-12
Appendix E – Personal Computer Interface Cards	E-1
IC693PIF301/400 Personal Computer Interface (PCIF) Cards	E-1
Appendix F – Series 90-30 Heat Dissipation	F-1
Step 1: Basic Method to Calculate Module Dissipation	F-1
Step 2: Calculation for PLC Power Supplies	F-2
Step 3: Output Calculations for Discrete Output and Combination Modules ..	F-2
Step 4: Input Calculations for Discrete Input or Combination Modules	F-4
Step 5: Final Calculation	F-6
Other Information Related to Enclosure Sizing	F-6

Figure 1-1. Example of a Series 90-30 I/O Module	1-2
Figure 2-1. Series 90-30 Example Layout	2-3
Figure 2-2. Features of Series 90-30 Module	2-4
Figure 2-3. Installing a Module	2-5
Figure 2-4. Removing a Module	2-6
Figure 2-5. Installing an I/O Module’s Terminal Board	2-7
Figure 2-6. Removing a Module’s Terminal Board	2-8
Figure 2-7. Terminal Board with Holding Screws	2-9
Figure 2-8. IC693ACC308 Front Mount Adapter Bracket Installation 2-11	2-11
Figure 2-9. Dimensions for 19I Rack Mounting Using IC693ACC308 Adapter Bracket	2-11
Figure 2-10. IC693ACC313 Recessed Adapter Bracket for 19” Rack Mounting . 2-12	2-12
Figure 2-11. Recommended System Grounding	2-13
Figure 2-12. Baseplate Grounding	2-14
Figure 2-13. 50-PIN I/O Module with Weidmuller #912263 Terminal Block . 2-20	2-20
Figure 2-14. Analog Input Shield Grounding when Terminal Strip is Used . 2-27	2-27
Figure 2-15. Analog Input Connections to Common Conductors ...	2-28
Figure 2-16. Shields Connected to Analog Input Module Terminal Board .. 2-29	2-29
Figure 2-17. Analog Input Module External Earth Ground Connection 2-30	2-30
Figure 2-18. 4–Wire Transducer, Externally Powered via AC or DC Supply . 2-31	2-31
Figure 2-19. 2–Wire Transducer, Externally Powered via DC Supply	2-31
Figure 2-20. 3–Wire Transducer, Externally Powered via DC Supply	2-32

Figure 2-21. 2–Wire Transducer, Self Powered	2-32
Figure 2-22. 2–Wire Transducer Connected to Two Measuring Devices 2-33	2-33
Figure 2-23. Shield Connections for Analog Output Modules	2-35
Figure 2-24. Analog Output Module with External Earth Ground Connection . 2-36	2-36
Figure 2-25. Analog Output Shield Grounding when Terminal Strip is Used 2-37	2-37
Figure 2-26. Power Supply Terminal Boards	2-39
Figure 2-27. Overvoltage Protection Devices and Jumper Strap	2-39
Figure 2-28. DC Input Wiring Examples	2-42
Figure 3-1. Common Baseplate Features	3-2
Figure 3-2. IC693CPU311 and IC693CPU313 5-Slot Embedded CPU Baseplates 3-5	3-5
Figure 3-3. IC693CPU323 10-slot Embedded CPU Baseplate	3-5
Figure 3-4. IC693CHS397 5-Slot Modular CPU Baseplate	3-6
Figure 3-5. IC693CHS391 10-Slot Modular CPU Baseplate	3-7
Figure 3-6. IC693CHS398 5-Slot Expansion Baseplate	3-8
Figure 3-7. IC693CHS392 10-Slot Expansion Baseplate	3-9
Figure 3-8. IC693CHS399 5-Slot Remote Baseplate	3-10
Figure 3-9. IC693CHS393 10-Slot Remote Baseplate	3-11
Figure 3-10. I/O Bus Expansion Cables	3-12
Figure 3-11. Rack Number Selection Switch (Shown with Rack 2 Selected) . 3-15	3-15
Figure 3-12. Example of Connecting Expansion Baseplates	3-16
Figure 3-13. Example of Connecting Expansion and Remote Baseplates 3-17	3-17
Figure 3-14. Model 311 and 313 5-Slot Baseplate Dimensions and Spacing Re-	

quirements	3-18
Figure 3-15. Model 323 10-Slot Baseplate Dimensions and Spacing Requirements	3-19
Figure 3-16. Modular CPU, Expansion, and Remote 5-Slot Baseplate Dimensions and Spacing Requirements	3-19
Figure 3-17. Modular CPU, Expansion, and Remote 10-Slot Baseplate Dimensions and Spacing Requirements	3-20
Figure 3-18. IC693ACC308 Front Mount Adapter Bracket Installation ...	3-22
Figure 3-19. Dimensions for 19I Rack Mounting Using IC693ACC308 Adapter Bracket	3-23
Figure 3-20. IC693ACC313 Recessed Mount Adapter Bracket	3-23
Figure 4-1. Standard AC/DC Input Power Supply - IC693PWR321 .	4-2
Figure 4-2. High Capacity AC/DC Input Power Supply - IC693PWR330	4-4
Figure 4-3. Overvoltage Protection Devices and Jumper Strap	4-6
Figure 4-4. Series 90-30 24/48 VDC Input Power Supply - IC693PWR322 ...	4-7
Figure 4-5. Typical Efficiency Curve for 24/48 VDC Power Supply ..	4-8
Figure 4-6. Series 90-30 48 VDC Input Power Supply - IC693PWR328	4-10
Figure 4-7. Typical Efficiency Curve for IC693PWR328 Power Supply	4-11
Figure 4-8. Series 90-30 24 VDC Input High Capacity Power Supply - IC693PWR331	4-13
Figure 4-9. 5 VDC Current Output Derating for Temperatures above 505C (1225F)	4-14
Figure 4-10. Series 90-30 12 VDC Input High Capacity Power Supply - IC693PWR332	4-16
Figure 4-11. 5 VDC Current Output Derating for Temperatures above 505C (1225F)	4-17
Figure 4-12. Overvoltage Protection Devices and Jumper Strap	4-21

Figure 4-13. Internal Power Supply Connections	4-21
Figure 4-14. Timing Diagram for all Series 90-30 Power Supplies ..	4-22
Figure 4-15. Serial Port Connector	4-23
Figure 4-16. Backup Battery for RAM Memory	4-24
Figure 5-1. Example of Series 90-30 Standard Density Discrete Output Module 5-4	
Figure 5-2. Example of 32-Point I/O Module (IC693MDL654) With Dual Con- nectors	5-5
Figure 5-3. Example of 32-Point I/O Module (IC693MDL653) With Single Con- nector	5-6
Figure 6-1. Field Wiring - 120 Volt AC Isolated Input Module - IC693MDL230 . 6-2	
Figure 6-2. Field Wiring - 240 Volt AC Isolated Input Module - IC693MDL231 . 6-4	
Figure 6-3. Field Wiring - 120 Volt AC Input Module - IC693MDL240	6-6
Figure 6-4. Input Points vs. Temperature for IC693MDL240	6-6
Figure 6-5. Field Wiring - 24 Volt AC/DC Pos/Neg Logic Input Module - IC693MDL241	6-8
Figure 6-6. Input Points vs. Temperature for IC693MDL241	6-8
Figure 6-7. Field Wiring - 125 Volt DC Positive /Negative Logic Input Module - IC693MDL632	6-10
Figure 6-8. Input Points vs. Temperature for IC693MDL632	6-10
Figure 6-9. Field Wiring - 24 Volt Positive/Negative Logic Input Module - IC693MDL634	6-12
Figure 6-10. Input Points vs. Temperature for IC693MDL634	6-12
Figure 6-11. Field Wiring - 24 Volt DC Positive/Negative Logic Input Module - IC693MDL645	6-14
Figure 6-12. Input Points vs. Temperature for IC693MDL645	6-14
Figure 6-13. Field Wiring - 24 Volt DC Pos/Neg Logic Input Module - IC693MDL646	6-16

Figure 6-14. Input Points vs. Temperature for IC693MDL646	6-16
Figure 6-15. IC693ACC300 Input Simulator Module	6-18
Figure 6-16. Field Wiring - 24 Volt Pos/Neg Logic 32 Point Input Module - IC693MDL653	6-20
Figure 6-17. Input Points vs. Temperature for IC693MDL654	6-22
Figure 6-18. Field Wiring 5/12 Volt DC (TTL) Pos/Neg Logic 32-Point Input Module - IC69MDL654	6-23
Figure 6-19. Input Points vs. Temperature for IC694MDL655	6-27
Figure 6-20. Field Wiring 24 Volt DC Positive/Negative Logic 32-Point Input Module - IC693MDL655	6-28
Figure 7-1. IC693DVM300 Digital Valve Driver Module	7-1
Figure 7-2. IC693MDL310 Output Module Field Wiring	7-5
Figure 7-3. Input Points vs. Temperature for IC693MDL310	7-5
Figure 7-4. Field Wiring - 120/240 Volt AC Output, 2 Amp Module - IC693MDL330	7-7
Figure 7-5. Input Points vs. Temperature for IC693MDL330	7-7
Figure 7-6. IC693MDL340 Output Module Field Wiring	7-9
Figure 7-7. Load Current vs. Temperature for IC693MDL340	7-9
Figure 7-8. IC693MDL390 Output Module Field Wiring	7-11
Figure 7-9. Load Current vs. Temperature for IC693MDL390	7-11
Figure 7-10. IC693MDL730 Output Module Field Wiring	7-13
Figure 7-11. Load Current vs. Temperature for IC693MDL730	7-13
Figure 7-12. Terminal Board with Holding Screws	7-14
Figure 7-13. IC693MDL731 Output Module Field Wiring	7-16
Figure 7-14. Load Current vs. Temperature for IC693MDL731	7-16
Figure 7-15. Terminal Board with Holding Screws	7-17
Figure 7-16. IC693MDL732 Output Module Field Wiring	7-19

Figure 7-17. Load Current vs. Temperature for IC693MDL732	7-19
Figure 7-18. IC693MDL733 Output Module Field Wiring	7-21
Figure 7-19. Load Current vs. Temperature for IC693MDL733	7-21
Figure 7-20. IC697MDL734 Output Module Field Wiring	7-23
Figure 7-21. Load Current vs. Temperature for IC693MDL734	7-23
Figure 7-22. IC693MDL740 Output Module Field Wiring	7-25
Figure 7-23. Load Current vs. Temperature for IC693MDL740	7-25
Figure 7-24. IC693MDL741 Output Module Field Wiring	7-27
Figure 7-25. Load Current vs. Temperature for IC693MDL741	7-27
Figure 7-26. IC693MDL742 Output Module Field Wiring	7-29
Figure 7-27. Load Current vs. Temperature for IC693MDL742	7-29
Figure 7-28. IC693MDL930 Output Module Field Wiring	7-31
Figure 7-29. Load Current vs. Temperature for IC693MDL930	7-31
Figure 7-30. Load Suppression Examples for IC693MDL930 Output Module . . 7-32	7-32
Figure 7-31. IC693MDL931 Output Module Field Wiring	7-34
Figure 7-32. Load Current vs. Temperature for IC693MDL931	7-34
Figure 7-33. Load Suppression Examples for IC693MDL931 Output Module . . 7-35	7-35
Figure 7-34. IC693MDL940 Output Module Field Wiring	7-37
Figure 7-35. Load Current vs. Temperature for IC693MDL940	7-37
Figure 7-36. Load Suppression Examples for IC693MDL940 Output Module . . 7-38	7-38
Figure 7-37. Field Wiring - 12/24 Volt DC Negative Logic 32 Point Output Module, IC693MDL750	7-40
Figure 7-38. Field Wiring - IC693MDL751 32 Point Output Module	7-42
Figure 7-39. Field Wiring - 5/24 Volt DC (TTL) Neg. Logic 32 Point Output Module -	

IC693MDL752	7-45
Figure 7-40. Examples of Connections to User Loads	7-46
Figure 7-41. Field Wiring - 12/24 Volt DC, 0.5A Positive Logic 32 Point Output Module - IC693MDL753	7-51
Figure 8-1. Field Wiring 120 VAC Input/Relay Output Module - IC693MAR590 8-4	
Figure 8-2. Field Wiring 24 VDC Input/Relay Output Module - IC693MDR390 . 8-8	
Figure 9-1. Example of Series 90-30 Analog Current Output Module	9-3
Figure 9-2. Analog Input Block Diagram	9-5
Figure 9-3. Analog Input Common Mode Voltage	9-5
Figure 9-4. Analog Output Block Diagram	9-6
Figure 9-5. D/A Bits vs. Current Output for IC693ALG391	9-8
Figure 9-6. Stair Step Effect on Analog Values	9-9
Figure 9-7. Voltage vs. Data Word	Figure 9-8. Current vs. Data Word 9-9
Figure 10-1. A/D Bits vs. Voltage Input	10-1
Figure 10-2. Scaling for Voltage Input	10-2
Figure 10-3. Analog Voltage Input Module Block Diagram for IC693ALG220 10-3	
Figure 10-4. Field Wiring for 4-Channel Analog Voltage Input Module	10-4
Figure 10-5. A/D Bits vs. Current Input	10-5
Figure 10-6. Scaling for Analog Current Input	10-6
Figure 10-7. Analog Current Input Module Block Diagram - IC693ALG221 10-7	
Figure 10-8. Field Wiring for 4 Channel Analog Current Input Module	10-8
Figure 10-9. 16-Channel Analog Voltage Input Module Block Diagram -	

IC693ALG222	10-11
Figure 10-10. A/D Bits vs. Voltage Input for IC693ALG222	10-12
Figure 10-11. Field Wiring for 16-Channel Analog Voltage Input Module - IC693ALG222 (Single-Ended Mode)	10-14
Figure 10-12. Field Wiring for 16-Channel Analog Voltage Input Module - IC693ALG222 (Differential Mode)	10-15
Figure 10-13. 16-Channel Analog Voltage Input Module Block Diagram - IC693ALG222	10-16
Figure 10-14. 16-Channel Analog Current Input Module Block Diagram - IC693ALG223	10-29
Figure 10-15. A/D Bits vs. Current Input for IC693ALG223	10-30
Figure 10-16. Field Wiring for 16-Channel Analog Current Input Module - IC693ALG223	10-40
Figure 10-17. Field Wiring - Alternate User Connections - IC693ALG223 ..	10-41
Figure 10-18. 16-Channel Analog Current Input Module Block Diagram - IC693ALG223	10-42
Figure 11-1. D/A Bits vs. Voltage Output	11-1
Figure 11-2. Scaling for Voltage Output	11-2
Figure 11-3. Analog Voltage Output Module Block Diagram - IC693ALG390	11-3
Figure 11-4. Field Wiring for Analog Voltage Output Module - IC693ALG390 ..	11-4
Figure 11-5. D/A Bits vs. Current	Fig-
Figure 11-6. D/A Bits vs. Current	Output, 4
to 20 mA	Output, 0
to 20 mA	11-5
Figure 11-7. Scaling for Current	Fig-
Figure 11-8. Scaling for Current	Output, 4
to 20 mA	Output, 0
to 20 mA	11-6

Figure 11-9. Load Current Derating	11-8
Figure 11-10. Analog Current Output Module Block Diagram - IC693ALG391 . 11-8	
Figure 11-11. Field Wiring - Analog Current Output Module (Current Mode) - IC693ALG391	11-9
Figure 11-12. Field Wiring - Analog Current Output Module (Voltage Mode) - IC693ALG391	11-10
Figure 11-13. Scaling for Current Output	11-12
Figure 11-14. Scaling for Voltage Output	11-12
Figure 11-15. Basic Block Diagram for IC693ALG392	11-13
Figure 11-16. Field Wiring for 8-Channel Analog Current/Voltage Output Module, IC693ALG392	11-15
Figure 11-17. Module Derating Curves for IC693ALG392	11-19
Figure 11-18. 8-Channel Analog Current/Voltage Output Module Block Diagram - IC693ALG392	11-30
Figure 12-1. A/D Bits vs. Current Input	12-4
Figure 12-2. A/D Bits vs. Voltage Input	12-5
Figure 12-3. Scaling for Current Output	12-6
Figure 12-4. Scaling for Voltage Output	12-6
Figure 12-5. Field Wiring for Analog Combo Module - IC693ALG442	12-10
Figure 12-6. Analog Combo Module Block Diagram - IC693ALG442	12-11
Figure 12-7. Output Behavior in Ramp Mode and in Standard Mode	12-18
Figure 13-1. Relationship of Indicator Lights to Terminal Board Connections . 13-1	
Figure C-1. Detail of I/O Bus Expansion Cables	C-2
Figure C-2. How to use Split-Ring Ferrules for Foil and Braided Cable Shield	C-6
Figure C-3. Point-To-Point Cable Wiring for Continuous Shield Custom Length Cables C-8	
Figure C-4. Point-To-Point Cable Wiring Diagram for Applications Requiring Less Noise Immunity	C-8
Figure C-5. Earlier Versions of Remote Baseplate Custom WYE Cable Wiring Diagram ..	C-9
Figure C-6. Current Remote baseplate (IC693CHS393/399) Custom Wye Cable Wiring Diagram	C-10

Figure C-7. Example of Connecting Expansion Baseplates	C-11
Figure C-8. Example of Connecting Expansion and Remote Baseplates	C-12
Figure C-9. 32 Point I/O Module to Weidmuller #912263 Terminal Block	C-14
Figure C-10. IC693CBL310 Cable.	C-16
Figure C-11. Dimensions for Depth of Connector in front of PLC	C-18
Figure C-12. IC693CBL315 Cable.	C-19
Figure C-13. Dimensions for Depth of Connector in front of PLC	C-22
Figure C-14. Connector Orientation on I/O Faceplate	C-24
Figure C-15. I/O Faceplate to Terminal Block Cable	C-24
Figure C-16. Dimensions for Depth of Connector in front of PLC	C-25
Figure C-17. IC693CBL327/328 Cables.	C-26
Figure C-18. Dimension for Depth of Connector for IC693CBL327/328	C-27
Figure C-19. Dimensions for Depth of Connector in front of PLC for Custom Built Cables C-30	
Figure C-20. IC693CBL329/330/331/332/333/334 Cables	C-31
Figure C-21. Dimension for Depth of Connector.	C-32
Figure D-1. Typical TBQC Terminal Block	D-1
Figure D-2. IC693ACC334 TBQC Faceplate	D-5
Figure D-3. IC693ACC329 TBQC Terminal Block	D-6
Figure D-4. IC693ACC330 TBQC Terminal Block	D-7
Figure D-5. IC693ACC331 TBQC Terminal Block	D-8
Figure D-6. IC693ACC332 TBQC Terminal Block	D-9
Figure D-7. IC693ACC333 TBQC Terminal Block	D-10
Figure D-8. Example of 32-Point, dual–connector Module (IC693MDL654)	D-11
Figure D-9. IC693ACC337 TBQC Terminal Block	D-13
Figure E-1. Example of PCIF Interface to Series 90-30 I/O	E-2

Table 3-1. Rack Number Selection Switch Settings	3-14
Table 3-2. Series 90-30 Baseplate Comparison	3-24
Table 4-1. Power Supply Comparison Table	4-1
Table 4-2. IC693PWR321 Power Supply Capacities	4-2
Table 4-3. Specifications for IC693PWR321 Standard AC/DC Input Power Supply 4-3	4-3
Table 4-4. IC693PWR330 Power Supply Capacities	4-4
Table 4-5. Specifications for IC693PWR330 High Capacity AC/DC Input Power Supply	4-5
Table 4-6. IC693PWR322 Power Supply Capacities	4-7
Table 4-7. Specifications for IC693PWR322 Power Supply	4-8
Table 4-8. IC693PWR328 Power Supply Capacities	4-10
Table 4-9. Specifications for IC693PWR328 Power Supply	4-11
Table 4-10. IC693PWR331 Power Supply Capacities	4-13
Table 4-11. Specifications for IC693PWR331 Power Supply	4-14
Table 4-12. High Capacity 12 VDC Input Power Supply Capacities .	4-16
Table 4-13. Specifications for IC693PWR332	4-17
Table 4-14. Load Requirements (in milliamps)	4-26
Table 5-1. Guide to Chapter Location for Discrete I/O Module Specifications .. 5-2	5-2
Table 6-1. Specifications for IC693MDL230	6-1
Table 6-2. Specifications for IC693MDL231	6-3
Table 6-3. Specifications for IC693MDL240	6-5
Table 6-4. Specifications for IC693MDL241	6-7
Table 6-5. Specifications for IC693MDL632	6-9
Table 6-6. Specifications for IC693MDL634	6-11

Table 6-7. Specifications for IC693MDL645	6-13
Table 6-8. Specifications for IC693MDL646	6-15
Table 6-9. Specifications for IC693ACC300	6-17
Table 6-10. Specification for IC693MDL653	6-19
Table 6-11. Specifications for IC693MDL654	6-22
Table 6-12. Specifications for IC693MDL655	6-27
Table 7-1. IC693DVM300 Specifications	7-2
Table 7-2. IC693DVM300 Connections	7-3
Table 7-3. Specifications for IC693MDL310	7-4
Table 7-4. Specifications for IC693MDL330	7-6
Table 7-5. Specifications for IC693MDL340	7-8
Table 7-6. Specifications for IC693MDL390	7-10
Table 7-7. Specifications for IC693MDL730	7-12
Table 7-8. Specifications for IC693MDL731	7-15
Table 7-9. Specifications for IC693MDL732	7-18
Table 7-10. Specifications for IC693MDL733	7-20
Table 7-11. Specifications for IC693MDL734	7-22
Table 7-12. Specifications for IC693MDL740	7-24
Table 7-13. Specifications for IC693MDL741	7-26
Table 7-14. Specifications for IC693MDL742	7-28
Table 7-15. Specifications for IC693MDL930	7-30
Table 7-16. Load Current Limitations for IC693MDL930	7-32
Table 7-17. Specifications for IC693MDL931	7-33
Table 7-18. Load Current limitations for IC693MDL931	7-35

Table 7-19. Specifications for IC693MDL940	7-36
Table 7-20. Load Current Limitations for IC693MDL940	7-38
Table 7-21. Specifications for IC693MDL750	7-39
Table 7-22. Specifications for IC693MDL751	7-41
Table 7-23. Specifications for IC693MDL752	7-44
Table 7-24. Specifications for IC693MDL753	7-50
Table 8-1. Specifications for IC693MAR590	8-2
Table 8-2. Load Current Limitations for IC693MAR590	8-2
Table 8-3. Specifications for IC693MDR390	8-6
Table 8-4. Load Current Limitations for IC693MDR390	8-6
Guide to Chapter Location for Analog I/O Module Specifications ..	9-1
Table 9-1. Load Requirements (mA) for Analog I/O Modules	9-4
Table 9-2. Equation Values for Analog Modules	9-7
Table 9-3. User Reference and Current (mA) Requirements	9-12
Table 9-4. User References Available per System	9-12
Table 9-5. Maximum Number of Analog Modules per System	9-12
Table 10-1. Specifications for Analog Voltage Input Module - IC693ALG220 10-3	
Table 10-2. Specifications for Analog Current Input Module - IC693ALG221 10-6	
Table 10-3. Specifications for 16-Channel Analog Voltage Input Module, IC693ALG222	10-10
Table 10-4. Terminal Pin Assignments for IC693ALG222	10-13
Table 10-5. Configuration Parameters for IC693ALG222	10-17
Table 10-6. Parameter Descriptions for Configuration	10-20
Table 10-7. Specifications for 16-Channel Analog Current Input Module, IC693ALG223	10-28

Table 10-8. Configuration Parameters	10-30
Table 10-9. Parameter Descriptions for Configuration	10-33
Table 10-10. Terminal Pin Assignments	10-39
Table 11-1. Specifications for Analog Voltage Output Module, IC693ALG390 .. 11-2	
Table 11-2. Range Settings vs. Voltage Outputs	11-6
Table 11-3. Specifications for Analog Current Output Module - IC693ALG391 . 11-7	
Table 11-4. Terminal Pin Assignments for IC693ALG392	11-14
Table 11-5. Specifications for IC693ALG392	11-18
Table 11-6. Configuration Parameters for IC693ALG392	11-20
Table 12-1. Specifications for IC693ALG442	12-2
Table 12-2. Terminal Pin Assignments for IC693ALG442	12-9
Table 12-3. Configuration Parameters for IC693ALG442	12-12
Table 12-4. E2 COMMREQ Command Block Definitions	12-20
Table 12-5. COMMREQ Data Types	12-20
Table 12-6. E2 COMMREQ Data and Command Word Formats ...	12-21
Table 13-1. Fuse List for Series 90-30 Modules	13-6
Table 13-2. Spare/Replacement Parts	13-7
Table 13-3. Preventive Maintenance Table	13-8
Table 13-4. Technical Support Telephone Numbers	13-9
Table C-1. Expansion Port Pin Assignments	C-5
Table C-2. Wire List for 32 Point I/O Cables	C-15
Table C-3. Wire List for 24-Pin Connectors	C-17
Table C-4. Catalog Numbers for 24-Pin Connector Kits	C-20
Table C-5. Wire List for 24-Pin Connectors	C-21
Table C-6. Catalog Numbers for 24-Pin Connector Kits	C-28
Table C-7. Wire List for 24-Pin Connectors	C-29
Table C-8. TBQC Cable Cross-Reference Table	C-32
Table D-1. TBQC Terminal Block Selection Table	D-2
Table D-2. TBQC Cable Selection Table for 16-Point Modules	D-3
Table D-3. TBQC Cable Selection Table for 32-Point Modules	D-12

Table E-1. Personal Computer Interface Card Comparison Table E-1

Chapter 1

Introduction to the Series 90-30 I/O System

efesotomasyon.com

Please Read the Following Important Information

The Series 90™-30 I/O modules described in this manual can be controlled two ways:

1. *With a Series 90-30 Programmable Logic Controller (PLC).*
2. *With a Personal Computer (PC) that has an installed Personal Computer Interface card (or similar interface). This allows software on the PC to control and monitor Series 90-30 I/O.*

If you are using Series 90-30 I/O as part of a Series 90-30 PLC system, you should refer to GFK-0356, the *Series 90-30 Programmable Controller Installation manual*, for more information.

If you are using a Personal Computer to control the Series 90-30 I/O, refer to the documentation for the PCIF, your Personal Computer, and your application software for more information.

Series 90-30 System

A Series 90-30 PLC system can consist of:

- **Model 311, Model 313, or Model 323:** a single baseplate with embedded CPU .
- **Model 331, 340, 341 system:** a CPU baseplate and up to 4 expansion and /or remote baseplates.
- **Model 350, 351, 352, 360, 363, or 364 system:** a CPU baseplate with up to 7 expansion and/or remote baseplates.

A Series 90-30 I/O system controlled by a Personal Computer can consist of:

- A PC with an installed **IC693PIF301** card and up to 4 expansion and/or remote baseplates.
- A PC with an installed **IC693PIF400** card and up to 7 expansion and/or remote baseplates.

Series 90-30 I/O Module Types

GE Fanuc offers the following types of Series 90-30 I/O modules:

- **Discrete inputs** modules have either 8, 16, or 32 points.
- **Discrete outputs** output modules have from 5 to 32 points.
- **Discrete combination** modules have a combination of inputs and outputs on one module.
- **Analog input** modules are available with 4 or 16 channels.
- **Analog outputs** analog output modules have 2 or 8 channels.

- **Analog combination** module has 4 input channels and 2 output channels.

I/O modules are retained in their baseplates by molded latches that easily snap onto the upper and lower retainer slots of the baseplates. This is described in detail in Chapter 2. The following figure shows a typical Series 90–30 I/O module.

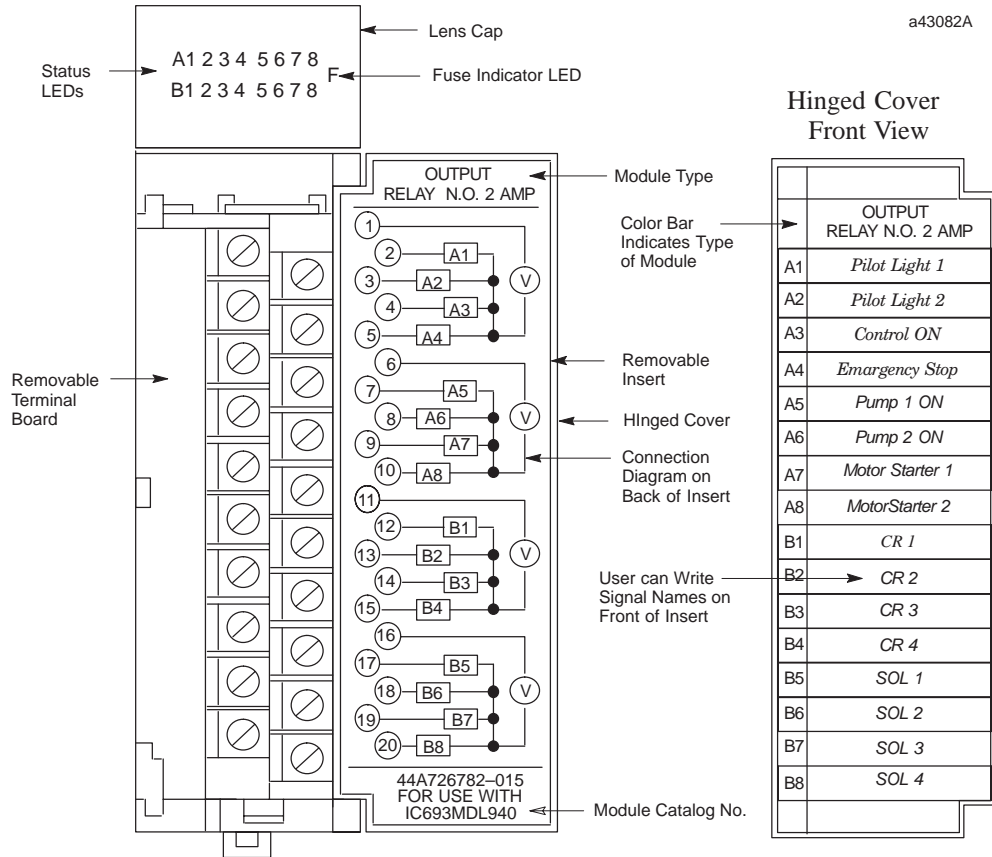

Figure 1-1. Example of a Series 90-30 I/O Module

LED Indicators

Circuit status of each I/O point on discrete modules is indicated by a green LED mounted at the top of the module and viewable through a clear plastic lens. There are two horizontal rows of LEDs with eight LEDs in each row. Each LED is identified by a letter and number identification which is illuminated when the applicable LED turns on. These letters and numbers clearly identify each LED to assist in program monitoring and trouble shooting. The top row is labeled A1 through 8 and the bottom row is labeled B1 through 8.

Additionally, a blown fuse status for fused or electronically protected output modules is provided by an LED labeled F on the LED cover (note that the F is labeled on all discrete I/O modules, although it is only relevant to fused or electronically protected output modules).

Front Door Insert

Each module has an insert that goes between the inside and outside surface of the hinged door. The surface towards the inside of the module (when the hinged door is closed) has circuit

wiring information for that module type, and the outside surface has space to record circuit identification information. The outside left edge of the insert is color coded so that you can quickly identify the module as an AC (red), DC (blue), or signal level (gray) type.

Universal Terminal Boards

Series 90-30 I/O modules with up to 16 points have, as a standard feature, detachable terminal boards for field wiring connections to and from user supplied input or output devices. This feature makes it easy to prewire field wiring to user supplied input and output devices, and to replace modules in the field without disturbing existing field wiring.

Terminal Block Quick Connect Assembly

The Terminal Block Quick Connect (TBQC) assembly allows some 16-point or 32-point discrete modules to be quickly connected to interposing terminal blocks. Installing a 16-point module typically takes 2 1/2 hours to wire from a PLC to interposing terminal blocks. With the TBQC, you simply snap in the interposing terminal block, remove the I/O module's terminal assembly, snap in the I/O faceplate and connect the cable. This reduces wiring time to about two minutes, reducing wiring cost and errors. Complete assemblies consist of a terminal block, an I/O Face Plate, and a cable. See Appendix D for more information.

Connections to High Density I/O Modules

High Density discrete I/O modules (32 Inputs or 32 Outputs) are connected to field devices through a cable, or cables, that plug into either one or two connectors on the front of the modules. These modules are discussed in detail in Chapters 5 and 6.

Option Modules

In addition to Series 90-30 I/O modules, the I/O system supports a wide variety of option modules, such as

- Genius Communications and Bus Controller
- Communications Control module (for serial communications)
- Programmable Coprocessor Modules and Alphanumeric Display Coprocessor
- Motion control and High Speed Counter modules
- Ethernet interface,
- Various bus controllers.
- State Logic modules

NOTE: the Programmable Coprocessor Modules, Communications Control module, Alphanumeric Display Coprocessor module, and the State Logic Processor modules *are currently NOT supported by the Personal Computer Interface (PCIF) cards.*

For current information on availability of Series 90-30 modules, consult your authorized GE Fanuc PLC distributor or your local GE Fanuc sales office.

Horner Electric and Third Party Modules

Series 90-30 compatible modules are available from Horner Electric, Inc. that may be used in a Series 90-30 PLC system or in a PCIF system. Some of these modules are listed below; there are many more. These modules may be ordered directly from Horner Electric, Inc. (telephone number is 317-639-4261, web address is www.hornerelectric.com).

Catalog Number	Description
HE693ASCxxx	ASCII BASIC Module
HE693ADCxxx	Isolated Analog Input Modules
HE693DACxxx	Isolated Analog Output modules
HE693APGxxx	IQ ² Remote I/O Interface Modules
HE693PIDxxx	PID modules
HE693STPxxx	Stepper Motor Modules
HE693ADCxxx	Strain Gauge Modules
HE693RTDxxx	RTD Modules
HE693THMxxx	Thermocouple Modules
HE693PIDNETE	PID Network Modules
HE693DRVNETA	Variable Frequency Drive Network Modules

Other Third party I/O modules are also available that can be included in a Series 90-30 PLC system. For information on Third party I/O modules, consult your authorized GE Fanuc PLC distributor or your local GE Fanuc sales office, or visit the GE Fanuc web site:

www.gefanuc.com

Chapter 2

General Installation Guidelines

efesotomasyon.com

This chapter discusses general installation details. Other, more specific details, for particular products are discussed in the applicable chapter.

– Important Note –

*The installation instructions described in this chapter apply to PLC installations that do not require special procedures for noisy or hazardous environments. For installations that must conform to more stringent requirements (such as CE Mark), see **GFK-1179, Installation Requirements for Conformance to Standards**. Also see Appendix B, “GE Fanuc Product Agency Approvals, Standards, General Specifications.”*

Receiving your Products – Visual Inspection

When you receive your Series 90-30 PLC system, carefully inspect all shipping containers for damage that may have occurred during shipping. If any part of the system is damaged, notify the carrier immediately. The damaged shipping container should be saved as evidence for inspection by the carrier.

As the consignee, it is your responsibility to register a claim with the carrier for damage that happened during shipment. However, GE Fanuc will fully cooperate with you if such action is necessary.

Pre-installation Check

After unpacking Series 90-30 PLC racks, cables, modules, etc., **record all serial numbers**. Serial numbers are printed on the module packaging. Serial numbers are required to make a claim during the warranty period of the equipment. All software product registration cards should be completed and returned to GE Fanuc. See the “Module Features” section in this chapter for location of module serial numbers. See the “Common Baseplate Features” section in the “Baseplates” chapter for location of baseplate serial numbers.

You should verify that all components of the system have been received and that they agree with your order. If the parts received do not agree with your order, call Programmable Control Customer Service, toll free, in Charlottesville, VA at 1-800-432-7521. A Customer Service representative will provide further instructions.

If you require assistance with your installation, the GE Fanuc *Technical Service Hotline* personnel in Charlottesville, VA are available to help you. North American customers should call toll-free at *1-800-GE FANUC (1-800-433-2682)*. International customers should dial direct: *804-978-6036*. The GE Fanuc web site support address is *www.gefanuc.com/support/plc*. Chapter 13, “Maintenance and Troubleshooting” has additional telephone numbers and troubleshooting information.

Warranty Claims

Record the serial number of the defective item and contact your distributor for instructions.

System Layout Guidelines

Because of the differences from one system to another, it is not practical to try to discuss every possible layout. Instead, this section offers guidelines and an example to help you lay out your system.

Benefits of a Good Layout – Safe, Reliable, and Accessible

The layout of your system has a lot to do with how reliably your system will operate, how easy it will be to install, how well it will look, and how easy and **safe** it will be to maintain:

- **Safety and Maintenance** – A good layout helps **minimize the chance of electrical shock to personnel working on the system**. It lets maintenance technicians easily access the unit to make measurements, load software, check indicator lights, remove and replace modules, etc. A good layout also makes it easier to trace wiring and locate components while troubleshooting, which helps reduce equipment downtime.
- **Reliability** – Proper layout promotes good heat dissipation and helps eliminate electrical noise from the system. Excess heat and noise are two major causes of electronic component failure.
- **Installation Efficiency** – A well designed layout allows sufficient room to mount and wire the unit. This saves time and frustration.
- **Appearance** – A neat and orderly layout gives others a favorable impression of your system. It lets others know that careful thought went into the design of the system.

PLC Rack Location and Clearance Requirement

The following list provides PLC rack mounting location guidelines. For an example layout, see the figure “Series 90-30 Example Layout” on the next page.

- Locate PLC racks away from other components that generate large amounts of heat, such as transformers, power supplies, or power resistors.
- Locate PLC racks away from components that generate electrical noise such as relays and contactors.
- Locate PLC racks away from high voltages components and wiring such as circuit breakers and fusible disconnects, transformers, motor wiring, etc. This not only reduces the chance of introducing electrical noise into the PLC, but makes it safer for personnel working on the PLC.
- Locate PLC racks at a convenient level that allows technicians reasonable access for maintaining the system.
- Route sensitive input wires away from electrically noisy wires such as discrete output and AC wiring. This can be facilitated by grouping I/O modules to keep Output modules separated from sensitive Input modules.
- The PLC racks each require a 4” clearance space on all four sides (6 inches on the right end if using I/O Bus Expansion Cables) to ensure adequate ventilation/cooling. See the “Baseplates” chapter for baseplate size and clearance requirement information.

Series 90-30 PLC Layout Example

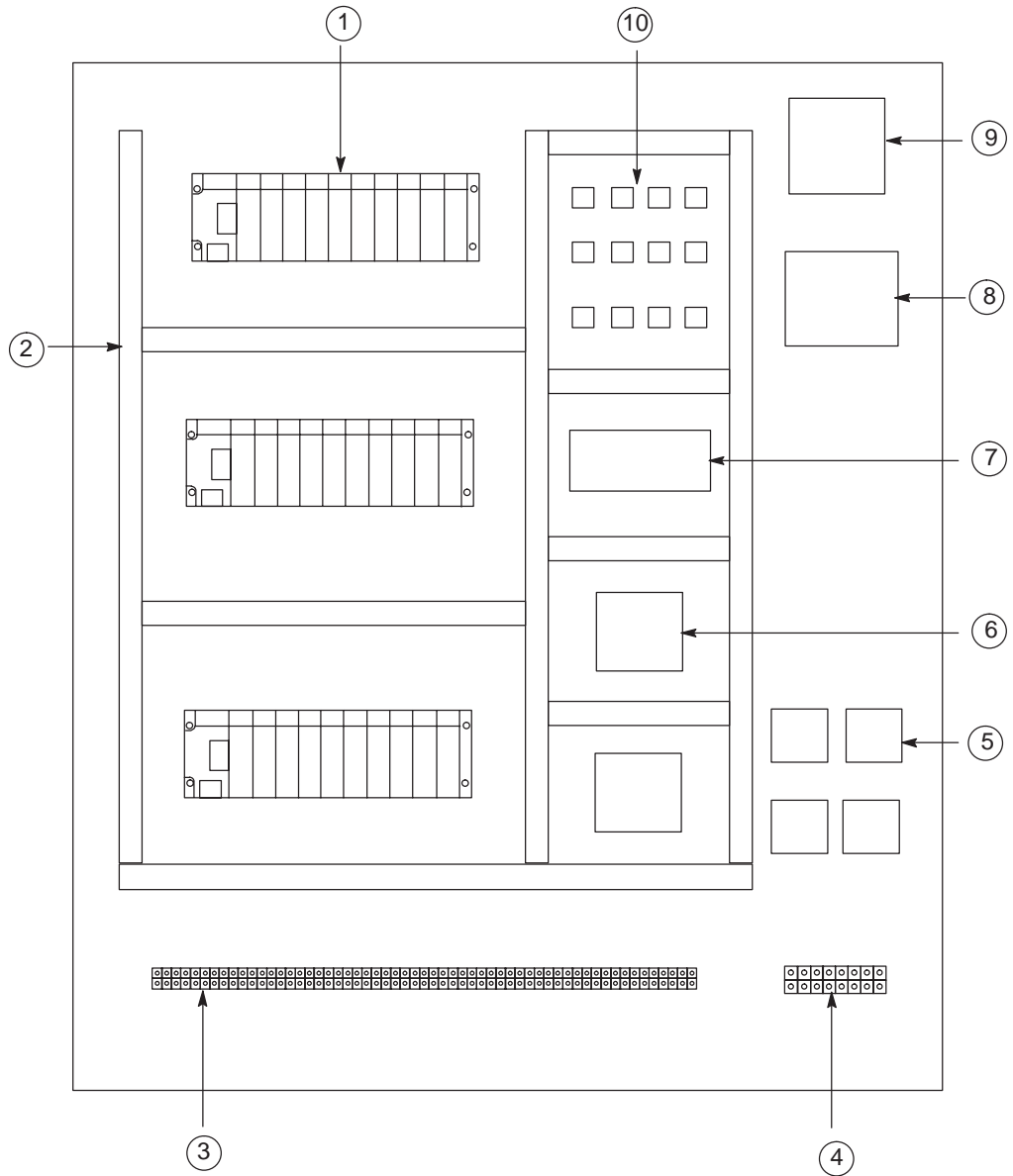

Figure 2-1. Series 90-30 Example Layout

1. Series 90-30 PLC, 10-slot rack
2. Wireway (Wire Duct)
3. Field device connection terminal block
4. Motor connection terminal block
5. Motor starters
6. Circuit board
7. Power supply
8. Control transformer
9. Fusible disconnect or circuit breaker
10. Control relays

Working with Series 90-30 Modules

Module Features

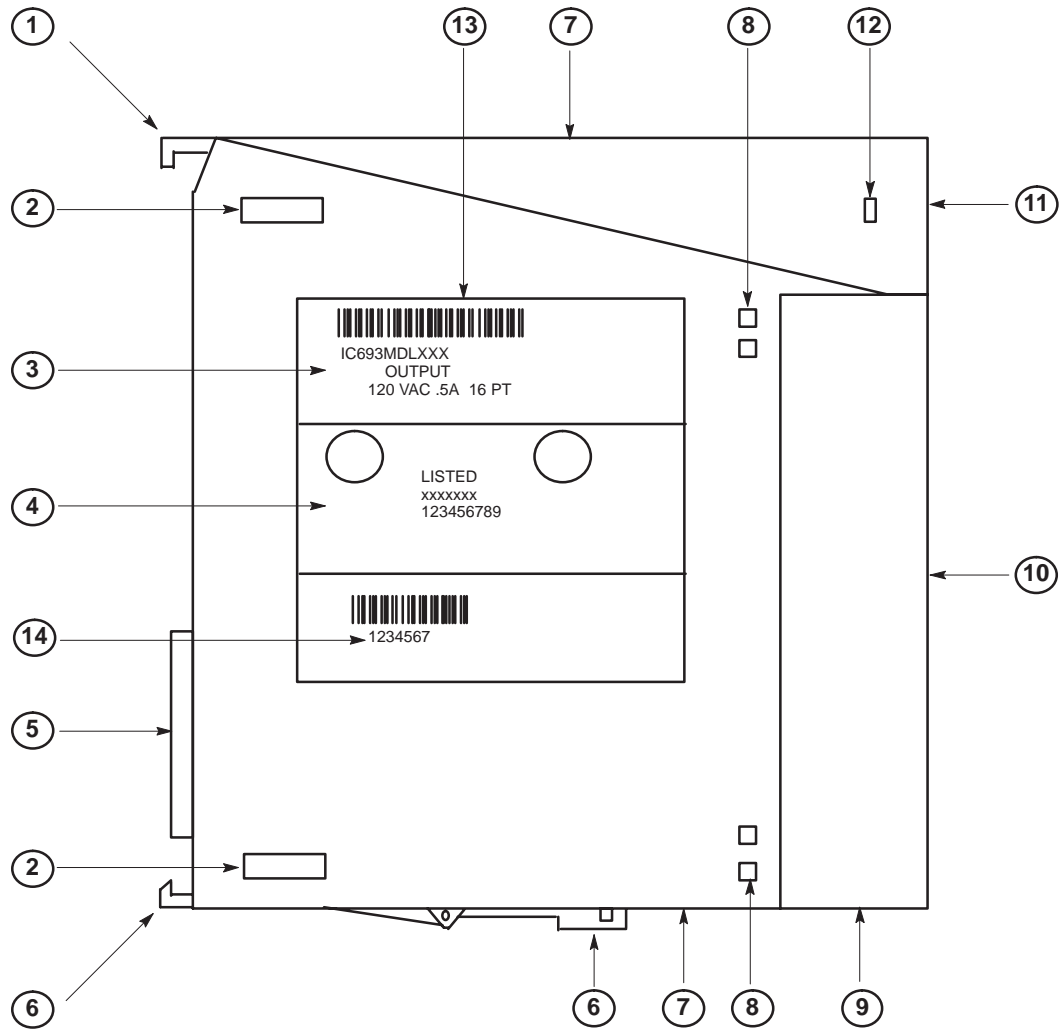

Figure 2-2. Features of Series 90-30 Module

1. Pivot hook
2. Circuit board holding tabs (two on each side of module)
3. Catalog number and description section of label
4. Certification (UL, CE, etc.) section of label
5. Module connector – plugs into baseplate backplane connector
6. Release lever – spring loaded
7. Ventilation openings in module case (top and bottom)
8. Front cover holding tabs (two on each side of module)
9. Front cover (shown) or terminal board.
10. Front cover faceplate or hinged cover for terminal board.
11. Lens cap.
12. Lens cap holding tabs (one on each side of module)
13. Module label
14. Serial Number – used to determine module warranty status. Note that on some modules, the Serial Number may be on a small tag on the back of the module.

Installing a Module

Warning

Do not insert or remove modules with power applied. This could cause the PLC to stop or malfunction. Injury to personnel and damage to the module or baseplate may result. Also, attempts to force a module into an improper slot type will result in damage to the module and/or the baseplate. Modules will mount in the correct slot type easily, with a minimum of force.

Use the following instructions as a guide when inserting a module into a baseplate slot.

- Check that module catalog number matches slot configuration. Each slot is, or will be, assigned a particular module type during configuration. A Power Supply module must be installed in the left end unnumbered slot only, and a CPU module and some special Option modules can only be installed in Slot 1 of a CPU baseplate. I/O Modules and most Option modules install in slots numbered 2 and higher.
- Grasp the module firmly with terminal board toward you and with rear pivot hook facing away from you.
- Align the module with the desired baseplate slot and connector. Tilt the module upwards so that top rear pivot hook of the module engages the baseplate's top module retainer.
- Swing the module downward until the module's connector engages the baseplate's backplane connector, and the release lever on the bottom of the module snaps into place in the baseplate's bottom module retainer.
- Visually inspect the module to be sure that it is properly seated.

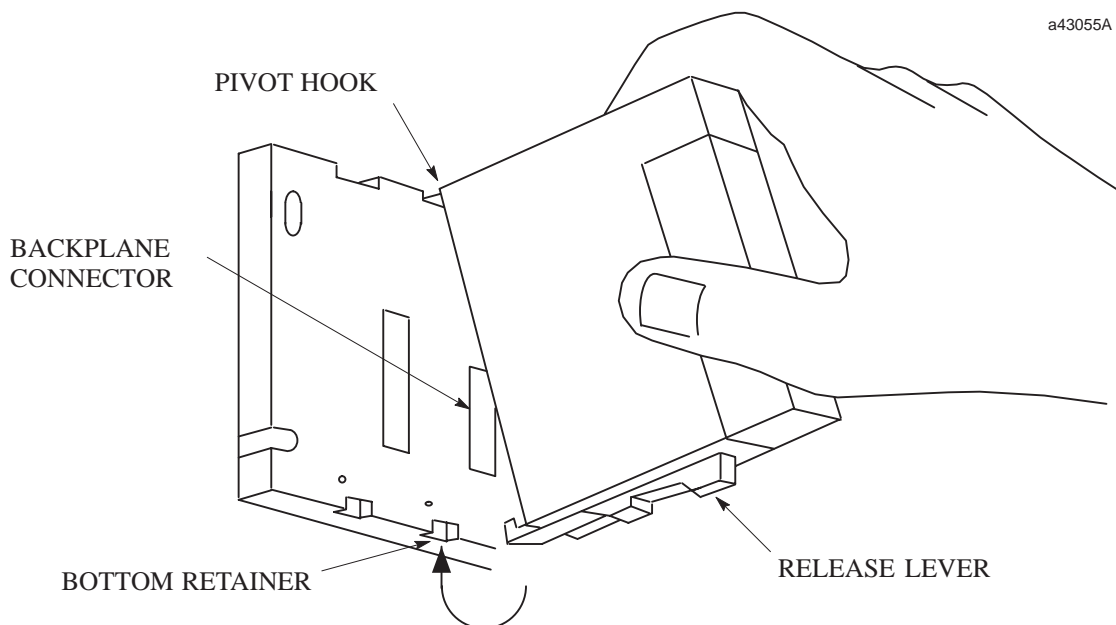

Figure 2-3. Installing a Module

Removing a Module

Warning

Do not insert or remove modules with power applied. This could cause the PLC to stop or malfunction. Injury to personnel and damage to the module or baseplate may result. Also potentially dangerous voltages from user devices may be present on a module's screw terminals even though power to the rack is turned off. Care must be taken any time that you are handling the module's removable terminal board or any wires connected to it.

- If the module has wiring, remove the module's terminal board (NOTE: You do not have to unwire the terminal board) or cables. The procedure for removing a terminal board is described later in this section.
- Locate the release lever at the bottom of the module and firmly press it up, towards the module.
- While holding the module firmly at its top and fully depressing release lever, swing (pivot) the module upward (release lever must be free of its retaining slot).
- Disengage pivot hook at the top rear of the module by moving the module up and away from the baseplate.

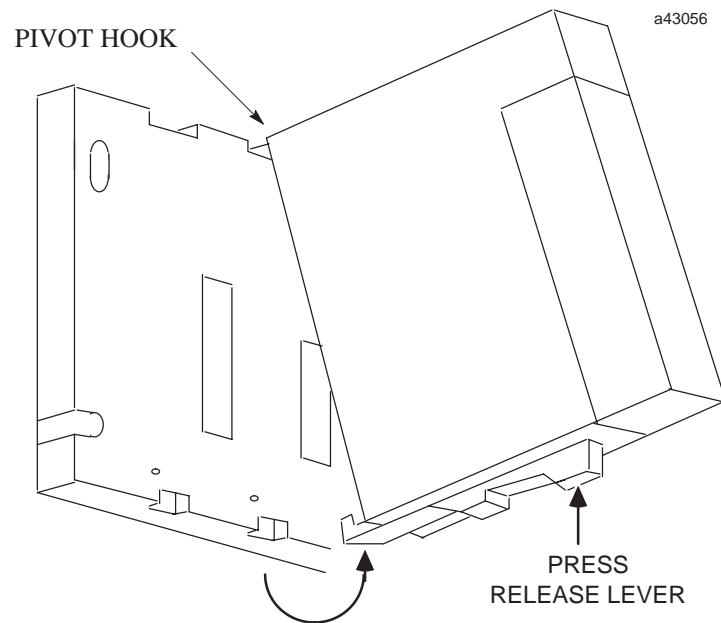

Figure 2-4. Removing a Module

Note

Modules in expansion or remote baseplates can be added, removed, or replaced while the PLC is in RUN mode if power is first removed from the expansion or remote baseplate. I/O data to/from this baseplate will not be updated while power is removed.

Installing a Module's Terminal Board

Note: Modules IC693MDL730F (and later) and IC693MDL731F (and later) have special terminal boards that are equipped with holding screws. For Installation and Removal instructions, please see the section “Installing and Removing Terminal Boards with Holding Screws” later in this chapter. The high density (32 point) I/O modules have one or two connectors instead of terminal boards.

To install a terminal board (refer to the figure below):

1. Hook the pivot hook, located on the bottom of the terminal board, to the lower slot on the module.
2. Push the terminal board towards the module until it snaps into place.
3. Open the terminal board cover and ensure that the latch on the module is securely holding the terminal board in place.

Caution

Compare the module catalog number on the label on the back of the hinged door (see Figure 2-8) and the label on the side of the module (see figure below) to ensure that they match. If a wired terminal board is installed on the wrong module type, damage to the module may occur when the system is powered up.

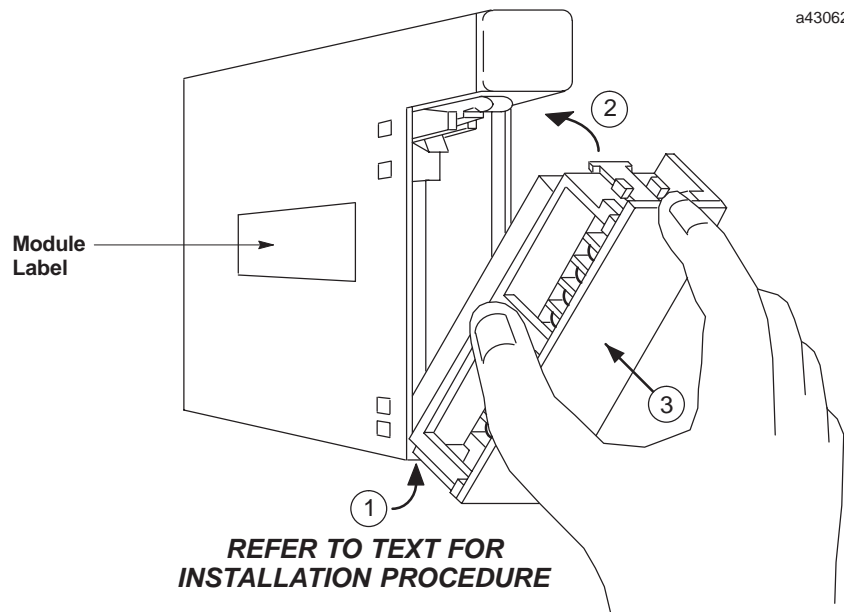
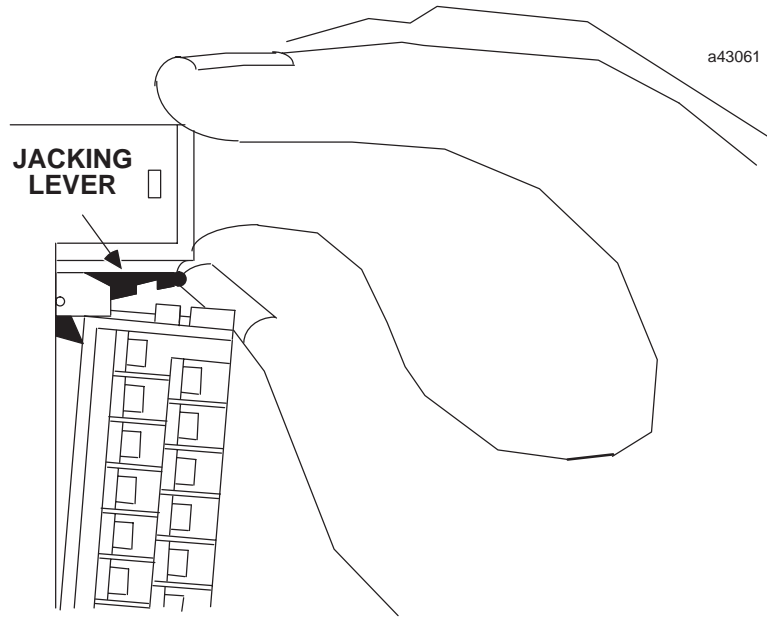

Figure 2-5. Installing an I/O Module's Terminal Board

Removing a Module's Terminal Board

To remove a terminal board:

- Open the plastic terminal board cover.
- Push up on the jacking lever to release the terminal block.



- Grasp pull-tab and pull it towards you until contacts have separated from module housing and bottom pivot hook has disengaged.

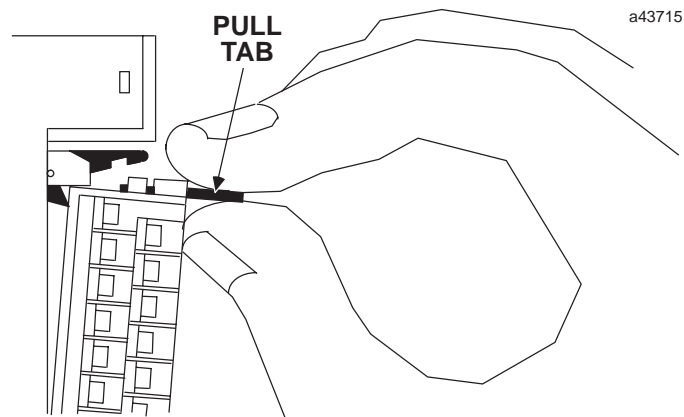

Figure 2-6. Removing a Module's Terminal Board

I/O Module Terminal Board Posts

Notice that the terminal board has three posts on the left side. The top and bottom posts hold the terminal board cover in place. The purpose of the middle post is to keep the terminal board wiring in place. This middle post can be easily snapped off if you do not require it to hold the wiring in place.

Since minimal force is required to snap off the middle post, you should be careful that you do not inadvertently snap it off if you are using it to keep your wiring in place.

Installing and Removing Terminal Boards with Holding Screws

Discrete output modules IC693MDL730F (and later) and IC693MDL731F (and later) have a special terminal board that is equipped with holding screws, shown in the figure below. These screws prevent the terminal board-to-module connections from deteriorating in applications where the PLC is subjected to severe vibration.

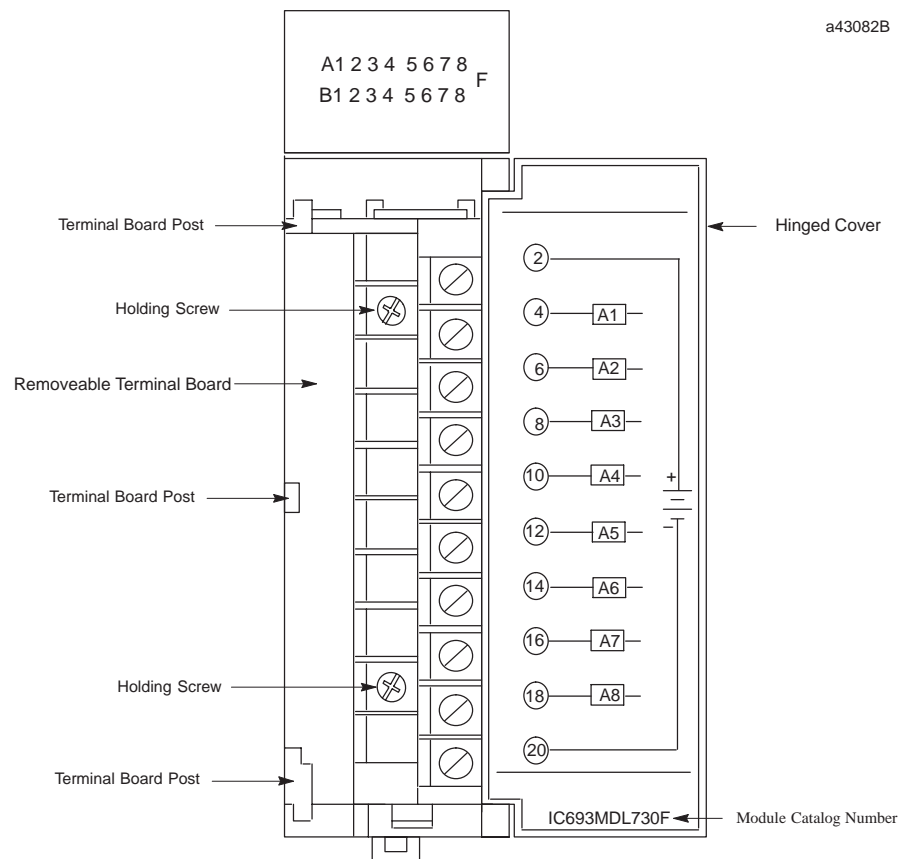

Figure 2-7. Terminal Board with Holding Screws

- Removing:** To Remove these terminal boards, first loosen the two holding screws on the front of the terminal board, then follow the standard removal instructions in the section “Removing an I/O Module’s Terminal Board.” The holding screws are held captive in the terminal board and do not have to be completely removed.
- Installing:** To install these terminal boards, follow the standard installation instructions in the section “Installing an I/O Module’s Terminal Board,” then tighten the two holding screws to 8 to 10 inch pounds (1 Newton-meter) of torque.

Baseplate Installation and Mounting

Warning

Be sure to follow baseplate grounding instructions in this chapter. Failure to properly ground the PLC can result in improper operation, damage to equipment, and injury to personnel.

Mounting a Baseplate to a Panel

- Use four good-quality (corrosion resistant) 8-32 x 1/2 (4 x 12 mm) machine screws, lock washers, and flat washers. Install the screws in four tapped holes. Chapter 3 (“Baseplates”) has the applicable dimensions and mounting clearances. (Alternately, 10-slot baseplates can be mounted in standard 19-inch racks by using the appropriate adapter. This is discussed in the next section.)
- A vertical mounting orientation is preferred for maximum heat dissipation. Other mounting orientations will require derating the Power Supply current capabilities. Please see the section “Load Ratings, Temperature, and Mounting Position” in Chapter 3 for information on this.
- All baseplates must be grounded. The “Baseplate Safety Grounding” section of this chapter has details.
- The Rack Number Selection switch must be set on each Expansion or Remote baseplate. A CPU baseplate does not require this switch. Rack numbers should be assigned by the system designer. Failure to set the Rack Number Selection switches properly will result in system malfunction. See Chapter 3 for details on setting these switches.

Mounting a Baseplate to a 19” Rack

Two optional Baseplate Adapter Brackets allow a 10-slot baseplate to be mounted in a 19 inch rack. Each baseplate installation requires only one of the adapter brackets.

- **IC693ACC308 Front Mount Adapter Bracket.** Used to mount a baseplate to the front face of a 19” rack. Install the adapter bracket by inserting the tabs at the top and bottom of the adapter bracket into the corresponding slots at the top and bottom of the plastic baseplate cover. **NOTE: Although the figure below shows the plastic baseplate cover removed, this is for illustration purposes only. It is not necessary to remove the cover to install the bracket.** With the bracket in place, insert and tighten the two screws (included with the bracket) through the back of the baseplate holes into the threaded holes in the bracket.
- **IC693ACC313 Recessed Mount Adapter Bracket.** Used to recess mount a baseplate inside a 19” rack. A baseplate mounts on the rear panel of this adapter bracket using four 8-32 (4 mm) screws, nuts, lockwashers and flat washers. The Adapter Bracket bolts through its four slotted holes to the face of the 19” rack using applicable hardware (lockwashers recommended).

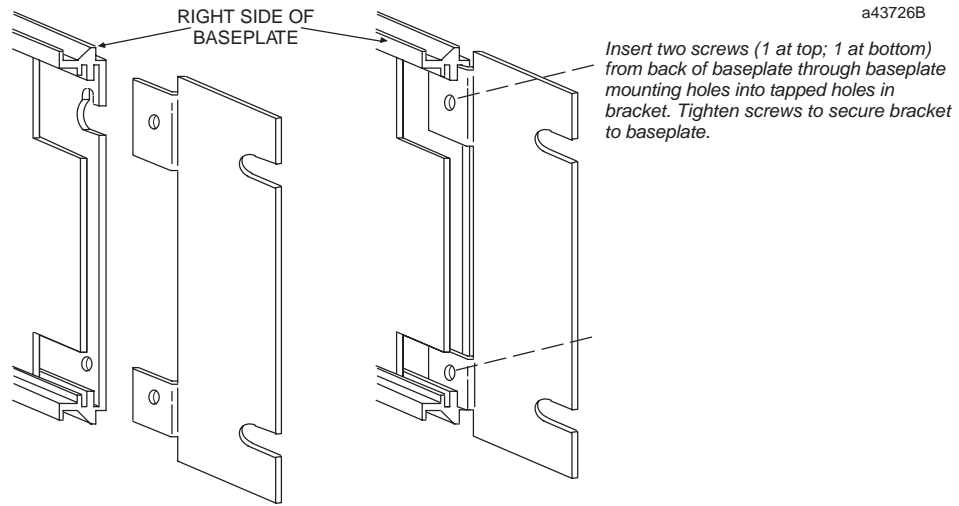

Note: Baseplate is shown with cover removed for illustration purposes. It is not necessary to remove the baseplate cover to install the bracket.

Figure 2-8. IC693ACC308 Front Mount Adapter Bracket Installation

Dimensions for rack mounting a 10-slot baseplate with the IC693ACC308 Front Mount Adapter Bracket are shown in the following figure.

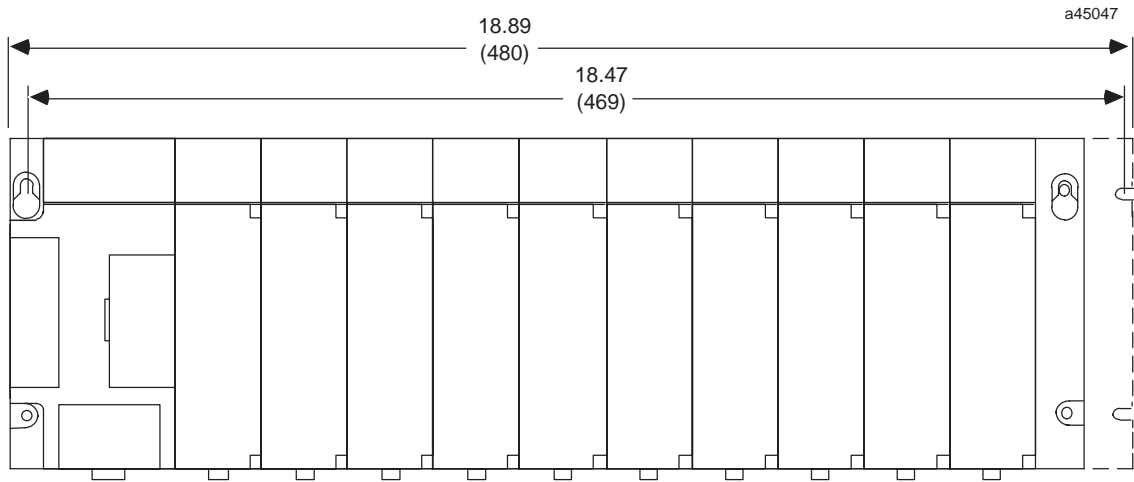

DIMENSIONS IN INCHES (MILLIMETERS IN PARENTHESES)

Figure 2-9. Dimensions for 19" Rack Mounting Using IC693ACC308 Adapter Bracket

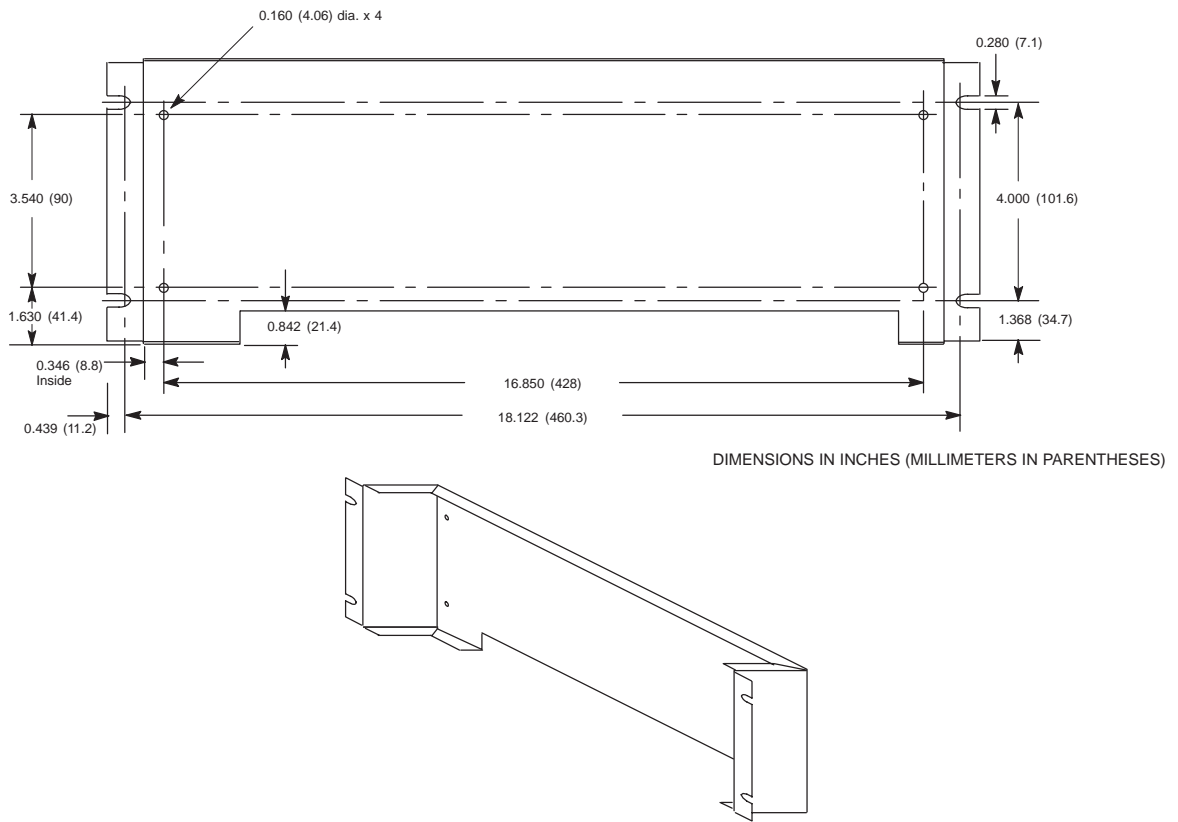

Figure 2-10. IC693ACC313 Recessed Adapter Bracket for 19" Rack Mounting

Grounding Procedures

System Grounding Procedures

Warning

In addition to the following grounding information, we strongly urge that you follow all applicable codes that apply to your area. For example, in the United States, most areas have adopted the National Electrical Code standard and specify that all wiring conform to its requirements. In other countries, different codes will apply. For maximum safety to personnel and property you must follow these codes. Failure to do so can mean injury or death to personnel, damage to property, or both.

All components of a programmable logic control system and the devices it is controlling must be properly grounded. This is particularly important for the following reasons.

- A low resistance path from all parts of a system to earth minimizes exposure to shock in the event of short circuits or equipment malfunction.
- The Series 90-30 PLC system requires proper grounding for correct operation.

The importance of a proper grounding cannot be over-emphasized.

Ground Conductors

- Ground conductors should be connected in a tree fashion with branches routed to a central earth ground point, shown in the figure below. This ensures that no ground conductor carries current from any other branch. This method is shown in the following figure.
- Ground conductors should be as short and as large in diameter as possible. Braided straps or AWG #12 (3.3 mm²) or larger cables (typically green insulation with a yellow tracer) can be used to minimize resistance. **Warning: Conductors must always be large enough to carry the maximum short circuit current of the path being considered.**

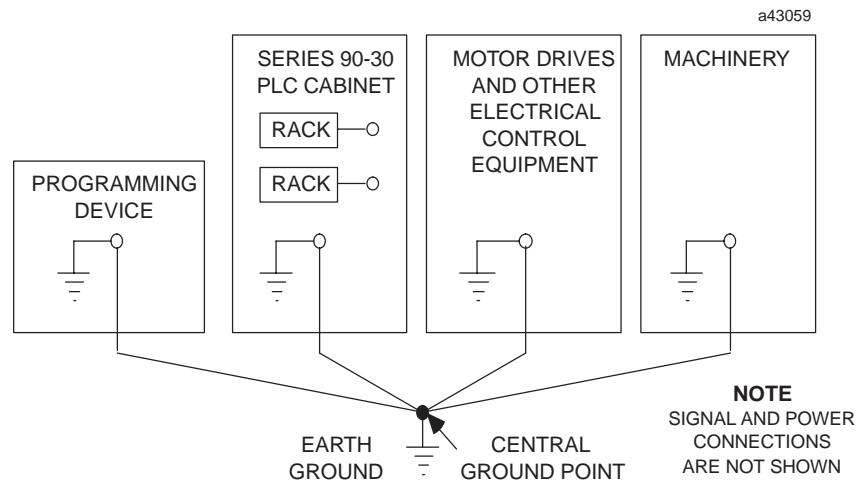

Figure 2-11. Recommended System Grounding

Series 90-30 PLC Equipment Grounding

Equipment grounding recommendations and procedures are listed below. These grounding procedures must be properly followed for safe, proper operation of your Series 90-30 PLC system.

Baseplate Safety Grounding

The following recommendations are offered, but applicable safety codes for your area or equipment type should also be consulted. The baseplate's metal back must be grounded using a separate conductor; the baseplate mounting screws are not considered to be an acceptable ground connection by themselves. Use a minimum AWG #12 (3.3 mm²) wire with a ring terminal and star lock washer under the head of one of the baseplate's two lower mounting holes. These two holes have openings to the side to allow connecting a wire and ring terminal under the head of a mounting screw. Connect the other end of this ground wire to a tapped hole in the panel that the baseplate is mounted to, using a machine screw, star lock washer, and flat washer. Alternately, if your panel has a ground stud, it is recommended you use a nut and star lock washer for each wire on the ground stud to ensure adequate grounding. Where connections are made to a painted panel, the paint should be removed so clean, bare metal is exposed at the connection point. Terminals and hardware used should be compatible with the aluminum baseplate material.

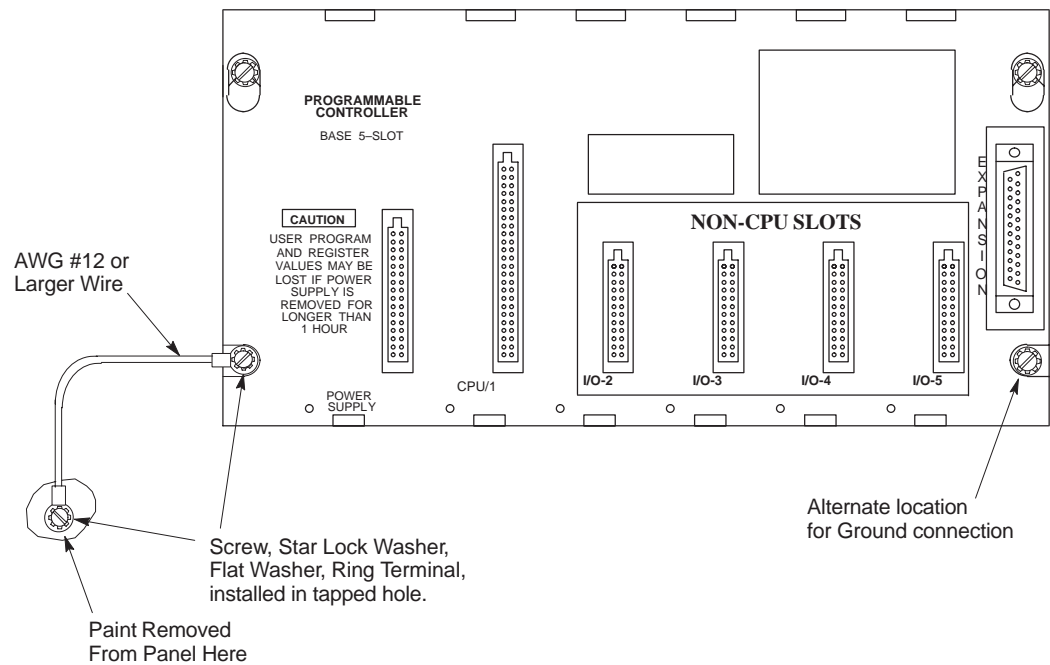

Figure 2-12. Baseplate Grounding

Warning

All baseplates must be grounded to minimize electrical shock hazard. Failure to do so can result in severe personal injury.

All baseplates grouped together in a Series 90-30 PLC system must have a common ground connection. This is especially important for baseplates that are not mounted in the same control cabinet.

Grounding 19” Rack-Mounted Baseplates

There are two Adapter Brackets choices for mounting a 10-slot Series 90-30 baseplate to a 19” Rack. Regardless of which of the two Adapter Brackets is used, the 19” Rack should be grounded as per the instructions in “System Grounding Procedures” section. (For details on the Adapter Brackets, see the “Mounting a Baseplate to a 19” Rack” section earlier in this chapter.)

Nineteen-Inch rack-mounted PLC baseplates should be grounded according to the guidelines in the “Baseplate Safety Grounding” section, using a separate ground wire from the PLC baseplate as shown in the previous figure.

- If using the **Recessed Mount Adapter Bracket (IC693ACC313)**, the ground wire can be installed as shown in Figure 2-11 with the ground attached to the Recessed Mount Adapter Bracket. An additional ground wire connecting the Adapter Bracket to a solid chassis ground on the 19” Rack should be installed. Use the same or equivalent hardware and paint removal scheme as shown in the previous figure.
- If using the **Surface Mount Adapter Bracket (IC693ACC308)**, the ground wire should be run from the baseplate as shown in Figure 2-11, to a solid chassis ground on the 19” Rack. Use the same or equivalent hardware and paint removal scheme as shown in the previous figure.

Programmer Grounding

For proper operation, a computer (programmer) running PLC software must have a ground connection in common with the applicable baseplate when connecting to a CPU or intelligent module such as a PCM or DSM. Normally, this common ground connection is provided by ensuring that the programmer’s power cord is connected to the same power source (with the same ground reference point) as the baseplate. If the programmer ground is at a different potential than the PLC ground, a shock hazard could exist. Also, damage to the ports or converter (if used) could occur when the programmer serial cable is connected between the two. If it is not possible to ensure this common ground scheme, use a port isolator (IC690ACC903) between the programmer and PLC serial port connection, and avoid touching the programmer and PLC at the same time.

Warning

Failure to follow programmer grounding recommendations could result in personal injury, equipment damage, or both.

Module Shield Grounding

In general, the aluminum PLC baseplate is used for module shield grounding. On many Series 90-30 I/O modules, shield connections to the removable terminal block on the module are routed to the baseplate through the module's backplane connector. Other modules, such as CPUs 351, 352, 363, and 364, require a separate shield ground. These modules come equipped with suitable grounding hardware. Grounding instructions for these CPUs are discussed in the *Series 90-30 Installation and Hardware Manual*, GFK-0356P (or later version).

Some of the Series 90-30 Option modules, such as the FIP Remote I/O Scanner (IC693BEM330), and DSM modules (IC693DSM302 and IC693DSM314) also have shield grounding requirements. These modules come equipped with suitable grounding hardware. Please refer to each module's user's manual for grounding instructions.

General Wiring Guidelines

Warning

In addition to the following wiring suggestions, we strongly urge that you follow all wiring and safety codes that apply to your area or your type of equipment. For example, in the United States, most areas have adopted the National Electrical Code standard and specify that all wiring conform to its requirements. In other countries, different codes will apply. For maximum safety to personnel and property you must follow these codes. Failure to do so can lead to personal injury or death, property damage or destruction, or both.

Color Coding Wires

These color codes are commonly used in industrial equipment manufactured in the United States. They are cited here as a reference. Where they are in conflict with codes that apply to your area or your type of equipment, you should follow your applicable codes instead. Besides satisfying code requirements, wire color coding makes testing and troubleshooting safer, faster, and easier.

- Green or green with stripe– Ground
- Black – Primary AC
- Red – Secondary AC
- Blue – DC
- White – Common or neutral
- Yellow – Secondary power source not controlled by the main disconnect. Alerts maintenance personnel that there may be power present (from an external source) even if the equipment is disconnected from its main power source.

Wire Routing

To reduce noise coupling among PLC wires, it is recommended you keep electrically noisy wiring, such as AC power wiring and Discrete Output Module wiring, physically separated from low-level signal wiring such as DC and Analog Input module wiring or communications cables. This can be accomplished by grouping separately, where practical, the following categories of wiring:

- **AC power wiring.** This includes the AC input to the PLC power supply, as well as other AC devices in the control cabinet.
- **Analog Input or Output Module wiring.** This should be shielded to further reduce noise coupling. See Chapter 9 for details.
- **Discrete Output Module wiring.** These often switch inductive loads that produce noise spikes when switched off.
- **DC Input Module wiring.** Although suppressed internally, these low-level inputs should be further protected against noise coupling by observing these wiring practices.

- **Communications Cables.** Wiring such as Genius Bus, Ethernet, or serial communications cables should be kept away from noise-producing wiring.

Where AC or Output wiring bundles must pass near noise-sensitive signal wiring bundles, avoid running them beside (parallel with) each other. Route them so that, if they have to cross, they do so at a right angle. This will minimize coupling between them.

Grouping Modules to Keep Wires Segregated

If practical, grouping similar modules together in the PLC racks can help keep wiring segregated. For example, one rack could contain only AC modules, and a different rack only DC modules, with further grouping in each rack by input and output types. For smaller systems, as an example, the left end of a rack could contain Analog modules, the middle could contain DC modules, and the right end could contain AC modules.

Discrete I/O Module Connection Methods

- For modules with 16 points or less, the standard method is to use the removable terminal board which comes with these modules. The removable terminal board makes it easy to prewire field wiring to the user supplied input and output devices, and to replace modules in the field without disturbing existing field wiring.
- Some discrete 16-point I/O modules can be used with an optional Terminal Block Quick Connect (TBQC) assembly. This assembly contains a module faceplate, with built-in connector, that replaces the removeable terminal board. The assembly also contains a DIN-rail mounted terminal block and a cable to connect the module to the terminal block. The advantage of this method is that it saves about two hours of wiring time per module compared with hand wiring from a module's removable terminal board to a user-supplied, panel-mounted terminal block or strip. See Appendix D for TBQC information.
- Older 32-point I/O modules have one 50-pin connector on the front of the module that is either connected by a cable with a connector on each end to a Weidmuller panel-mounted terminal block (Weidmuller catalog no. 912263), or is connected by a cable with stripped, tinned leads to a user-supplied terminal block or strip.
- Newer 32-point I/O modules have two 24-pin connectors on the front of the module. These module may be wired in one of three ways. (1) Use a pair of cables (IC693CBL327/328 – see data sheet in “Cables” chapter) to connect the module to a user-supplied, panel-mounted terminal block or strip. These cables have a 24-pin connector on one end, and stripped, tinned leads with wire markers on the other end. (2) Use a pair of dual-connector cables to connect the module to a Terminal Block Quick Connect (TBQC) terminal block (IC693ACC377). See Appendix D for details. (3) Make your own custom cables (instructions are found in the IC693CBL327/328 data sheet in Appendix C).

Connections to I/O Module Terminal Boards

Series 90-30 PLC I/O Module terminal boards have either 10 or 20 screw terminals that will accept from two AWG #22 (0.36 mm²) to two AWG #16 (1.3 mm²), or one AWG #14 (2.1 mm²) copper 90°C (194°F) wire(s). Each terminal can accept solid or stranded wires, but the wires into any given terminal should be the same type (both solid or both stranded) to ensure a good connection. Wires are routed to and from the terminals out of the bottom of the terminal board cavity. The suggested torque for the I/O terminal board connection screws is from 9.6 in-lbs to 11.5 in-lbs (1.1 - 1.3 Newton-meters).

For 24 volt DC input modules, an internal 24 volt power connection is provided on the terminal board to supply a limited number of input devices. Also, a 24 volt DC output is available on the power supply module's terminal board to supply a limited number of output devices.

Terminal Block Quick Connect Installation for 16-Point Discrete Modules

The Terminal Block Quick Connect (TBQC) Assembly is an option for certain Series 90-30 discrete I/O modules. (See Appendix D to select the applicable TBQC components.) If using this option, follow these installation steps:

- Remove standard terminal board from module. This terminal board will not be used with the TBQC components, so you may store it as a spare for other modules.
- Install the IC693ACC334 TBQC faceplate (it has a 24-pin connector).
- Mount the applicable TBQC terminal block. It has a 24-pin connector and a terminal strip, and mounts on a standard 35 mm DIN-rail. Mount the terminal block close enough to the PLC so the cable (see next step) will reach.
- Connect a TBQC cable between the TBQC faceplate connector on the module and the connector on the TBQC terminal block. Use one of the following cables:

Cable Catalog Number	Length
IC693CBL330	1.0 Meter
IC693CBL332	2.0 Meters
IC693CBL334	0.5 Meter

- Wire I/O devices to the terminal block.

Installation of 32-Point (50-Pin Connector) Discrete Modules

These 50-Pin modules are an older design and are not generally used on new systems, unless to fulfill standardization requirements. They are mainly used as replacements for existing installations. For new installations, we recommend the dual 24-pin connector style modules because they have additional features (LED indicators, TBQC terminal block IC693ACC337) not found on the older modules, and it is easier to fabricate custom-length cables for them. Installation information is provided here for the convenience of those still using these 50-pin connector modules.

Using Weidmuller #912263 Terminal Block

Note: Terminal Block Quick Connect (TBQC) components are not available for these modules, but you may purchase a Weidmuller #912263 terminal block from a Weidmuller distributor for this application. (For distributor information, visit the Weidmuller web site at www.weidmuller.com). See figure on next page for an example installation.

- Mount the Weidmuller #912263 terminal block. It has a 50-pin female Honda connector and a terminal strip, and mounts on a standard 35 mm DIN-rail. Mount the terminal block close enough to the PLC so the cable (see next step) will reach.
- Connect either an IC693CBL306 (3 feet/1 meter long) or an IC693CBL307 (6 feet/2 meters long) cable between the module's faceplate connector and the connector on the Weidmuller terminal block. See Appendix C for cable data.
- Wire I/O devices to the terminal block. See Chapters 5 ("Discrete Input Modules") or Chapter 6 ("Discrete Output Modules") for pin-out information.

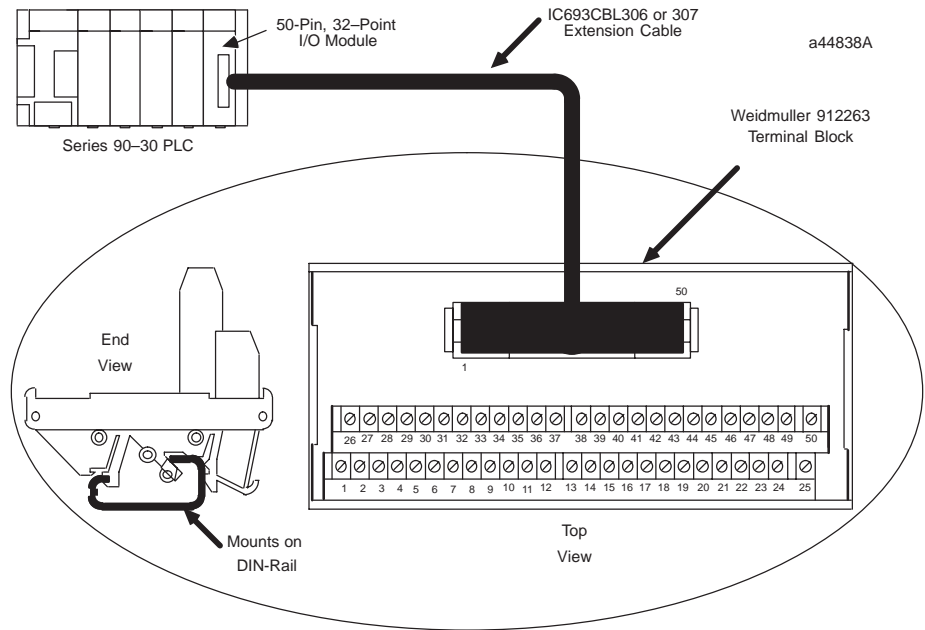

Figure 2-13. 50-PIN I/O Module with Weidmuller #912263 Terminal Block

Using Generic Terminal Block or Strip

- Mount terminal block/strip to the enclosure panel.
- Connect an IC693CBL308 cable (3 feet/1 meter), an IC693CBL309 cable (6 feet/2 meters), or a custom made cable, to the module's faceplate connector and wire the stripped ends of the cable to the terminal block/strip. See Appendix C for cable data.
- Wire I/O devices to the terminal block/strip.

Direct Method

Connect an IC693CBL308 cable (3 feet/1 meter), an IC693CBL309 cable (6 feet/2 meters), or a custom made cable, to the module's faceplate connector and wire the stripped ends of the cable directly to the field devices. See Appendix C for cable data. See the applicable chapter for module pin-out information.

Installation of 32-Point (Dual 24-Pin Connector) Discrete Modules

Using a TBQC

- Mount two TBQC terminal blocks. Each has a 24-pin connector and a terminal strip, and mounts on a standard 35 mm DIN-rail. Mount terminal blocks close enough to the PLC so the cable (see next step) will reach.
- Connect a pair of TBQC cables (IC693CBL329 – 334) between the module's faceplate connector and the connectors on the two TBQC terminal blocks. Note that both a right side and left side cable is required. TBQC cables come in several lengths. See Appendix D for a cable list.
- Wire I/O devices to the terminal blocks. See the applicable chapter for pin-out information.

With a Generic Terminal Block/Strip

- Mount terminal block/strip to the enclosure panel.
- Connect the IC693CBL327/328 cables, or custom made cables, to the module's faceplate connectors, and wire the stripped ends of the cables to the terminal block/strip. Note that both a right side (IC693CBL328) and left side (IC693CBL327) cable is required. See Appendix C for cable data sheets.
- Wire I/O devices to the terminal block/strip. See the applicable chapter for module pin-out information.

Direct Method

Connect the IC693CBL327 and IC693CBL328 cables (both are required), or custom made cables, to the module's faceplate connectors, and wire the stripped ends of the cables directly to the field devices. See Appendix C for cable data. See the applicable chapter for module pin-out information.

Terminal Block Selection Guide for Discrete I/O Modules

This section shows how to select terminal blocks and related components for three categories of discrete I/O modules:

1. 32-point input or output modules with a single 50-pin connector.
2. 16-point input or output modules with standard terminal boards.
3. 32-point input or output modules with two 24-pin connectors.

1. Applying a Terminal Block to 32-Point, 50-Pin Connector I/O Modules

NOTE: These modules cannot use Terminal Block Quick Connect (TBQC) components.

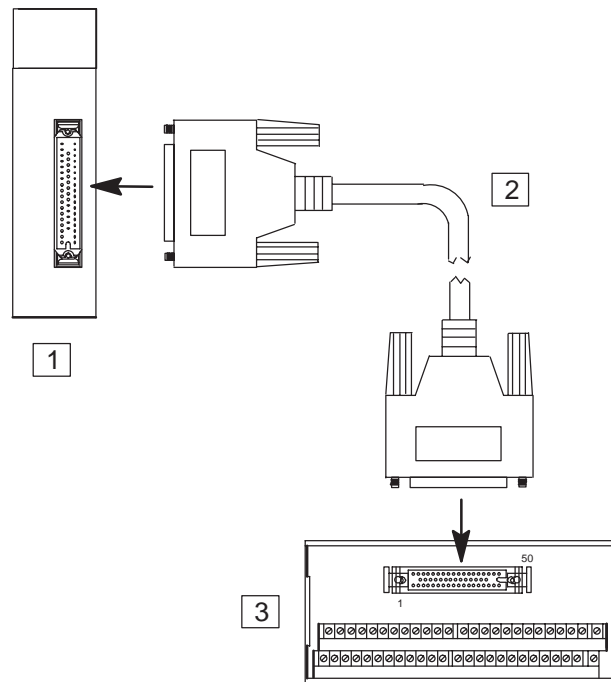

Procedure

The step numbers in the following procedure correspond to the numbers in the figure above. See Appendix C for cable data sheets.

1. Select a 32-point discrete I/O module with a 50-pin connector. There are four GE Fanuc modules in this category: IC693MDL652, IC693MDL653, IC693MDL750, and IC693MDL751.
2. Select a cable from the following table:

Cable Catalog Number	Length
IC693CBL306	1.0 Meter
IC693CBL307	2.0 Meters

3. Purchase a Wiedemuller #912263 terminal block from your electronics distributor. GE Fanuc does not sell this terminal block.

2. Applying TBQC Components to 16-Point Discrete I/O Modules

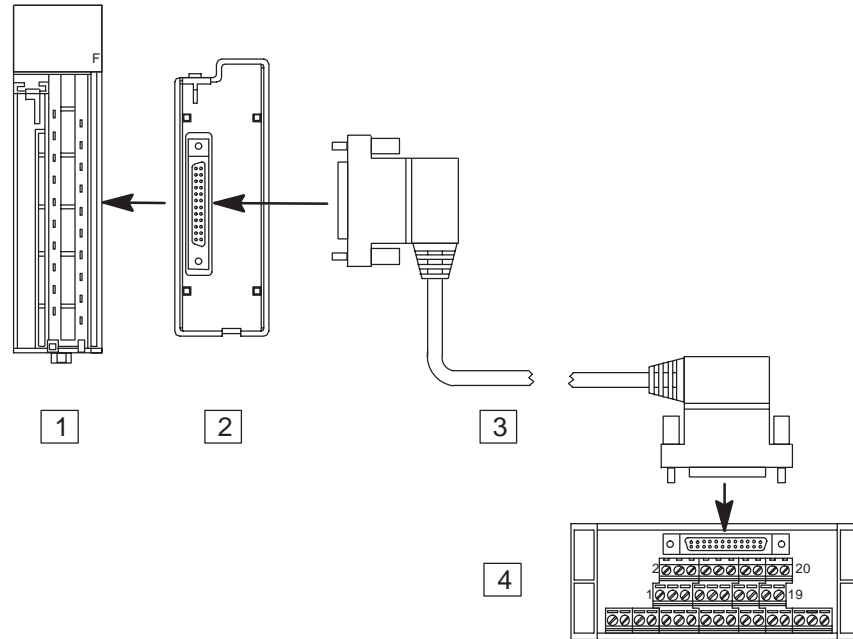

Procedure

The step numbers in this procedure refer to the numbers in the figure. See Appendix D for Terminal Block Quick Connect (TBQC) details and Appendix C for cable data sheets.

1. Select a 16-point discrete I/O module (see module list in table below).
2. Remove the terminal board from the module and attach an IC693ACC334 TBQC faceplate.
3. Select a cable from following table:

Cable Catalog Number	Length
IC693CBL330	1.0 Meter
IC693CBL332	2.0 Meters
IC693CBL334	0.5 Meter

4. Select the TBQC terminal block for your I/O module from following table:

Terminal Block Catalog Number	Use With These Modules	Module Description
IC693ACC329 ¹	IC693MDL240 IC693MDL645 IC693MDL646	Input, 120 VAC – 16 points Input, 24 VDC Pos./Neg Logic– 16 points Input, 24 VDC Pos./Neg, Logic – 16 points
IC693ACC330	IC693MDL740 IC693MDL742	Output, 12/24 VDC Pos Logic, 0.5A – 16 points Output, 12/24 VDC Pos Logic ESCP, 1A– 16 points
IC693ACC331	IC693MDL741	Output, 12/24 VDC Neg Logic, 0.5A– 16 points
IC693ACC332	IC693MDL940	Output, Relay, N.O. – 16 points
IC693ACC333	IC693MDL340	Output, 120 VAC, 0.5A – 16 points

¹ Terminal Block IC693ACC329 may be used with most discrete I/O modules that have up to 16 I/O points (cannot be used with 32 point modules). Jumpers may have to be added; see module specs. for wiring details.

3. Applying TBQC Components to 32-Point, Dual 24-Pin Connector I/O Modules

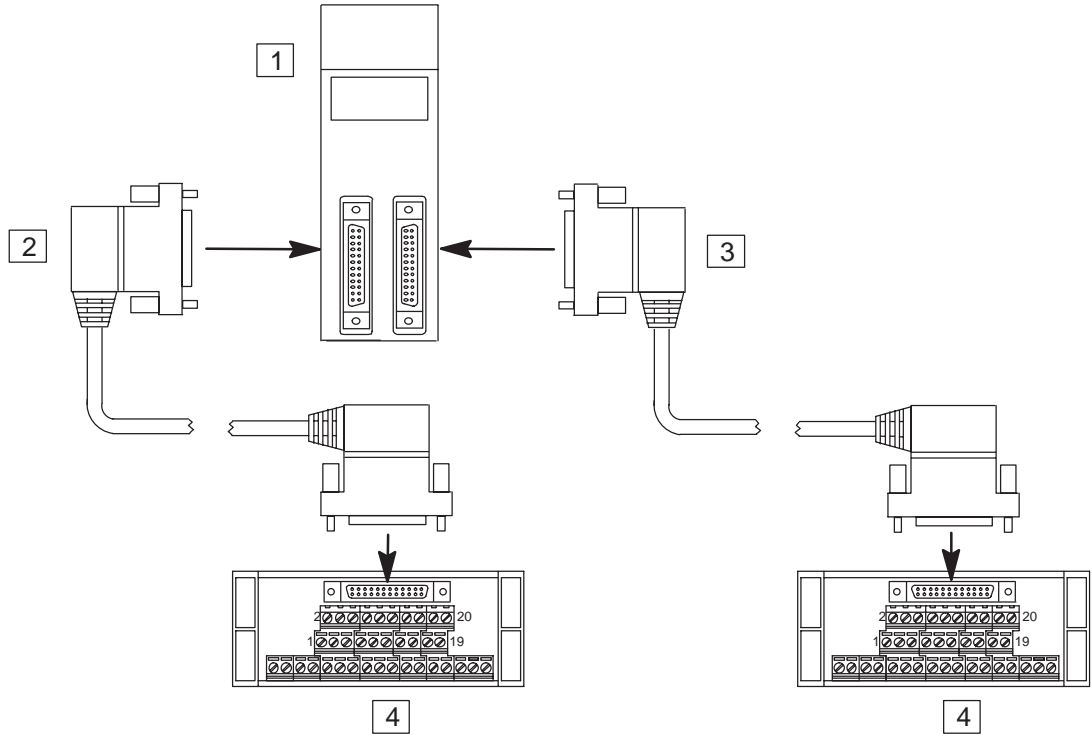

Procedure

The step numbers below refer to numbers in the figure above. See Appendix D for additional Terminal Block Quick Connect (TBQC) details and Appendix C for cable data sheets.

1. Select a 32-point I/O module with dual 24-pin connectors. There are four GE Fanuc modules in this category: IC693MDL654, IC693MDL655, IC693MDL752, and IC693MDL753.

2. Select a left-side cable from the following table:*

Left-Side Cable Catalog Number	Length
IC693CBL329	1.0 Meter
IC693CBL331	2.0 Meters
IC693CBL333	0.5 Meter

3. Select a right-side cable from the following table:*

Right-Side Cable Catalog Number	Length
IC693CBL330	1.0 Meter
IC693CBL332	2.0 Meters
IC693CBL334	0.5 Meter

4. Use two TBQC terminal blocks. (The only choice is catalog number IC693ACC337.)

* Note: You can purchase a cable kit that includes both cables. See Appendix D for details.

General Wiring Methods for Analog Modules

Twisted, shielded instrumentation cable is strongly recommended for analog module input or output signal connections. Proper grounding of the shield is also important. For maximum electrical noise suppression, the cable shield should only be grounded at one end of the cable. For Input modules, it is generally preferable to ground the end that is in the noisiest environment (usually the field device end). For Output modules, ground at the module end. See Chapters 10 (Analog Input), 11 (Analog Output), and 12 (Analog Combination) for additional wiring information for specific modules.

Connections to an Analog module from user devices are made to screw terminals on a removable 20-terminal connector block mounted on the front of the module. Actual terminals used are shown in the specifications for the individual modules.

General Analog Input Wiring Methods

The following methods are, for most applications, the preferred methods. However, in some applications, alternate methods may be used successfully. The examples shown later in this section discuss and illustrate a variety of possible wiring arrangements.

Using a Terminal Strip

- Mount a terminal strip inside the control enclosure and run a shielded cable from the terminal strip to each input circuit on the module's terminal board terminals.
- Connect each cable's shield to one point on the metal panel next to the terminal strip. When attaching to a painted surface, first remove the paint around the tapped hole and use an appropriate ring terminal, machine screw, lockwasher and flat washer. Do not connect the shields at the module end (cut shield off at module end of cable and insulate with shrink tubing).
- Wire the field device to the terminal strip with a shielded cable, grounding the shield at the device end only (cut shield off at terminal strip end of cable and insulate with shrink tubing). If attaching shields to a painted surface, first remove the paint around the connection. Also, keep the length of exposed (outside of shield) leads at the terminal strip and device ends as short as possible.

Direct Method

- Run a shielded cable from the field device (transducer, potentiometer, etc.) directly to the module.
- Connect the conductors to the applicable screws on the module's terminal board.
- Ground the shield at the field device end, exposing a minimum amount of conductor to the noisy environment. If attaching shields to a painted surface, first remove the paint around the tapped hole and use an appropriate ring terminal, machine screw, lockwasher and flat washer. Do not connect the shield at the module end (cut shield off at module end of cable and insulate with shrink tubing).

TBQC Not Recommended for Analog Modules

The Terminal Block Quick Connect (TBQC) Assembly is not recommended for use with analog modules due to cable shielding requirements.

Analog Input Module Wiring Methods for Noise Suppression

Correcting electrical noise problems can sometimes be a trial-and-error routine. In troubleshooting noise problems, sometimes it is beneficial to experiment with the shield ground point location. However, in general, it is usually best to ground the analog input cable shields as close to the source of the noise as possible, which is usually at the device (analog source) end. Cable shield should be grounded at one end only. Also, it is best to keep the length of stripped cable leads as short as possible to minimize the length of unshielded conductors that will be exposed to the noisy environment.

Shielding for Analog Input Modules

Generally, the shield for analog input cables should be grounded at the analog source, as shown in the next figure. However, ground connections for each channel, labeled COM and GND, on the terminal board are provided for connecting shields at the analog input module if appropriate. An analog input module's COM terminals connect to the analog circuit common in the module. The GND terminals connect to the baseplate (frame ground). The shields may be connected to either COM or GND.

Technological advances used in electronic circuit design are often aimed at making equipment smaller, faster, and more sensitive. This effort increases the concern for electrical noise. Therefore, shielding and grounding are important when installing a Series 90-30 PLC system.

It is impossible to provide a practical installation guide that covers all possible application designs. Sometimes, experimentation with different grounding methods under actual operating conditions is required to achieve maximum noise rejection. However, this section discusses four shield grounding examples for analog input modules that have proven effective for most cases.

Analog Input Shield Grounding Example One

For an unbalanced source, the ground shield should be connected to the source common or ground at the source end. If all of the source inputs to this module come from the same location and are referenced to the same common, all shield grounds should be connected to the same physical ground point. If using a terminal strip between the analog input module and the field devices (analog sources), use the method in the following figure for “continuing” each cable shield using a terminal on the terminal strip. Note that each cable is only grounded at one end – the end closer to the field devices (analog sources). Shield connections are shown in bold in the next figure.

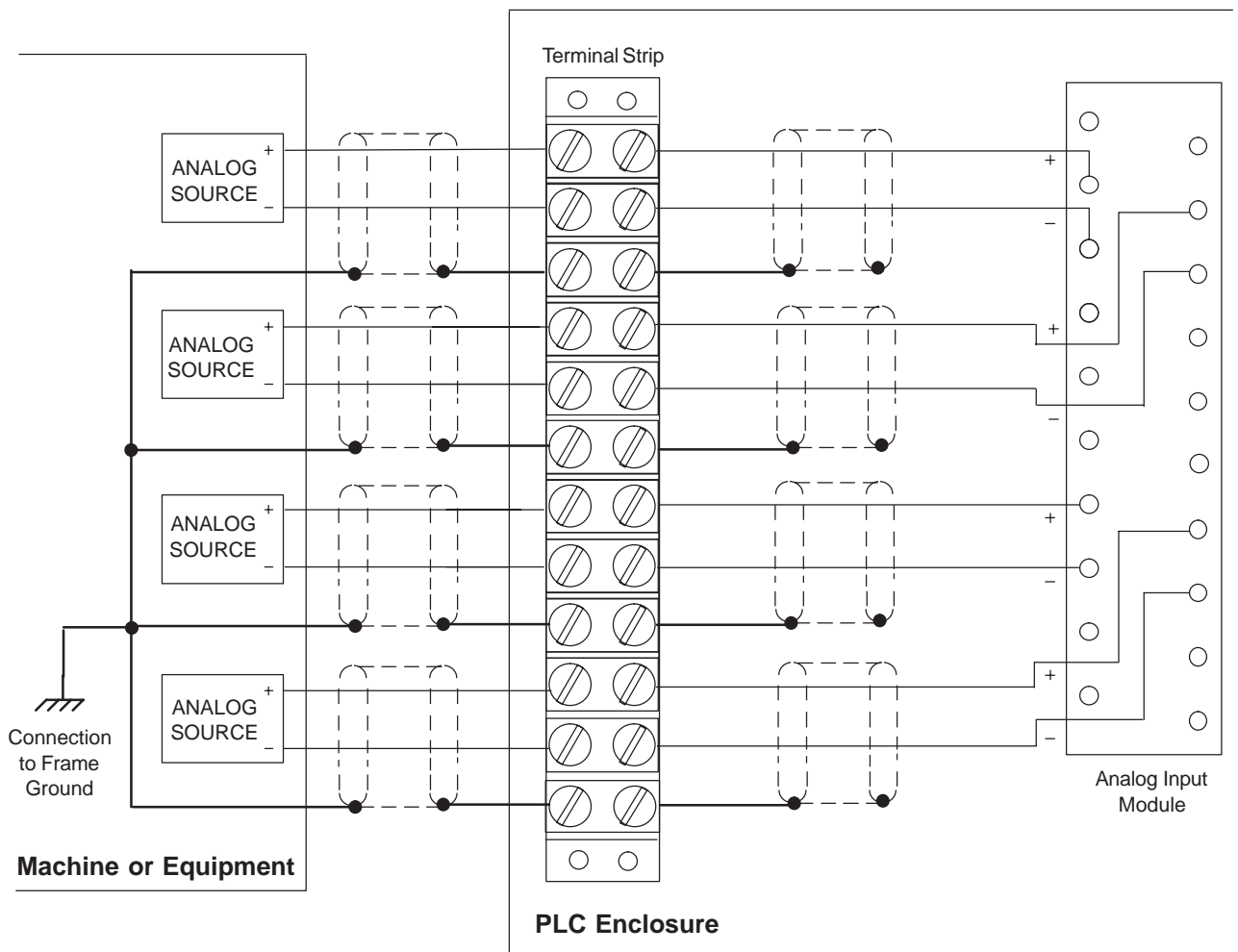

Figure 2-14. Analog Input Shield Grounding when Terminal Strip is Used

Analog Input Shield Grounding Example Two – Common Connection

In some applications, improved noise rejection can be obtained by connecting the source common points together at the source end, and then connecting a common line to the module at only one module COM terminal. This scheme will eliminate multiple grounding or ground loops that could cause false input data. In the following figure, the common connections just described are drawn in bold lines.

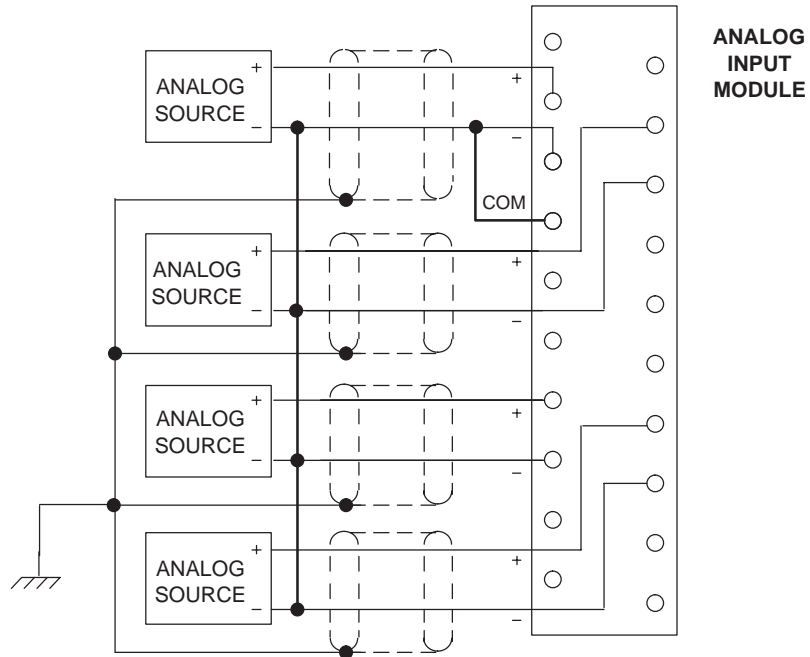

Figure 2-15. Analog Input Connections to Common Conductors

Analog Input Shield Grounding Example Three

It is usually preferable to ground cable shields at the source end. However, in cases where this may be difficult or in environments where electrical noise is not a major problem, it may be acceptable to ground cable shields at the analog input module end. In this case, you would connect them to one of the module's GND terminal screws (which is connected to frame ground through an internal PLC path). This cable grounding method is shown in the next figure in bold lines.

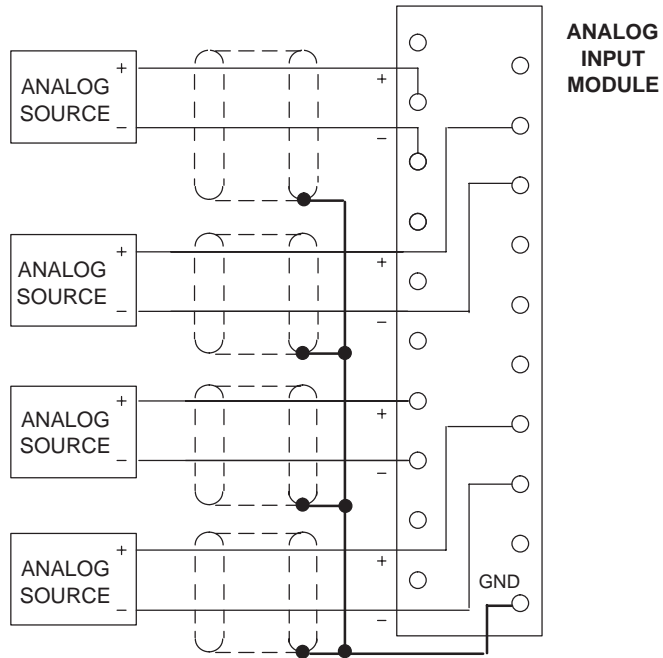

Figure 2-16. Shields Connected to Analog Input Module Terminal Board

Analog Input Shield Grounding Example Four

If using the method in the previous example, you may need to improve noise immunity. To accomplish this, a conductor may be used to connect the applicable ground terminal on the module's terminal board to earth ground. This additional connection will bypass noise around the module. The next figure shows the same shield grounding scheme as in the previous figure, but with the addition of the external ground connection just described, shown with bold lines.

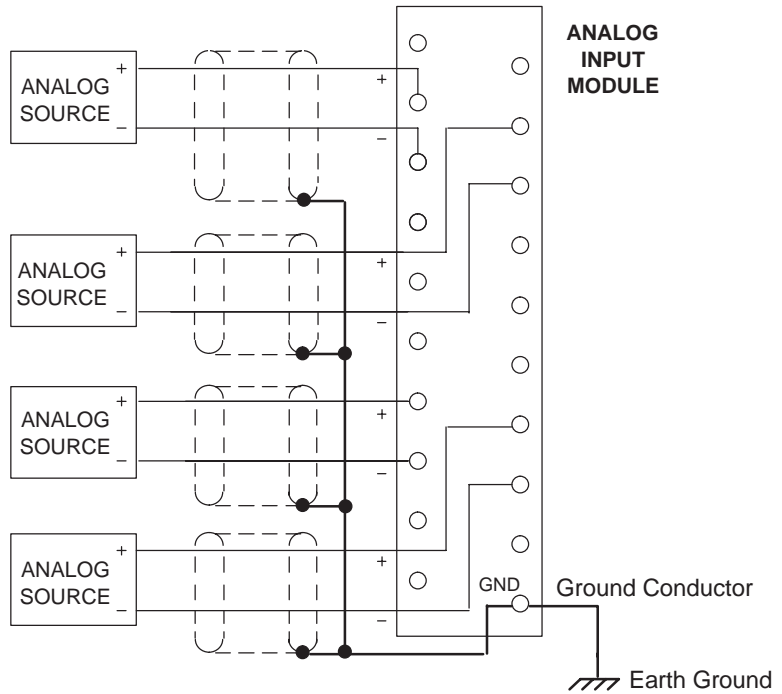
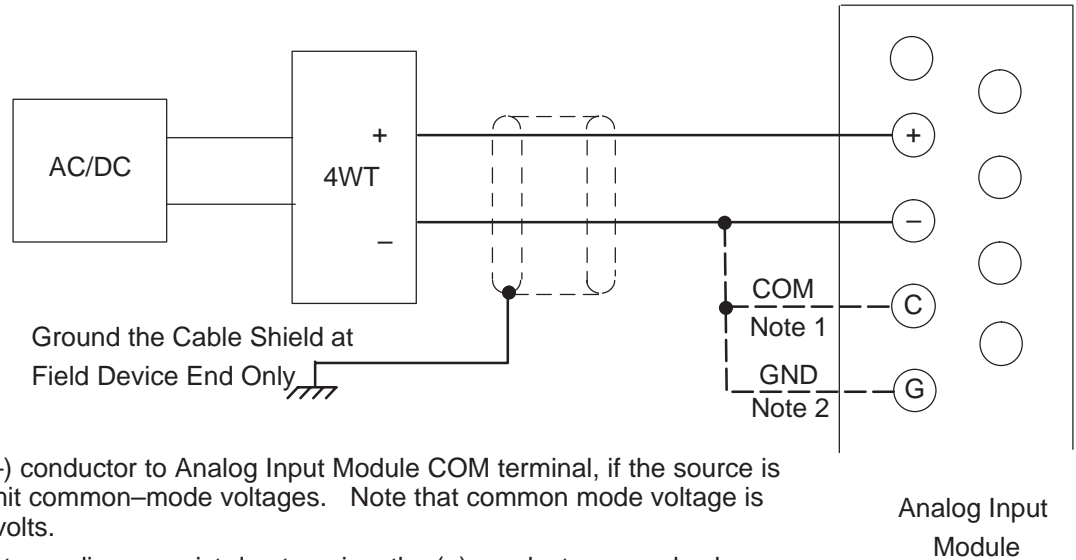

Figure 2-17. Analog Input Module External Earth Ground Connection

Wiring Diagrams for Current Transducers



NOTES:

1. Connect (-) conductor to Analog Input Module COM terminal, if the source is floating, to limit common-mode voltages. Note that common mode voltage is limited to 11 volts.
2. If inaccurate readings persist due to noise, the (-) conductor may also be connected to the Analog Input Module GND terminal.

Figure 2-18. 4-Wire Transducer, Externally Powered via AC or DC Supply

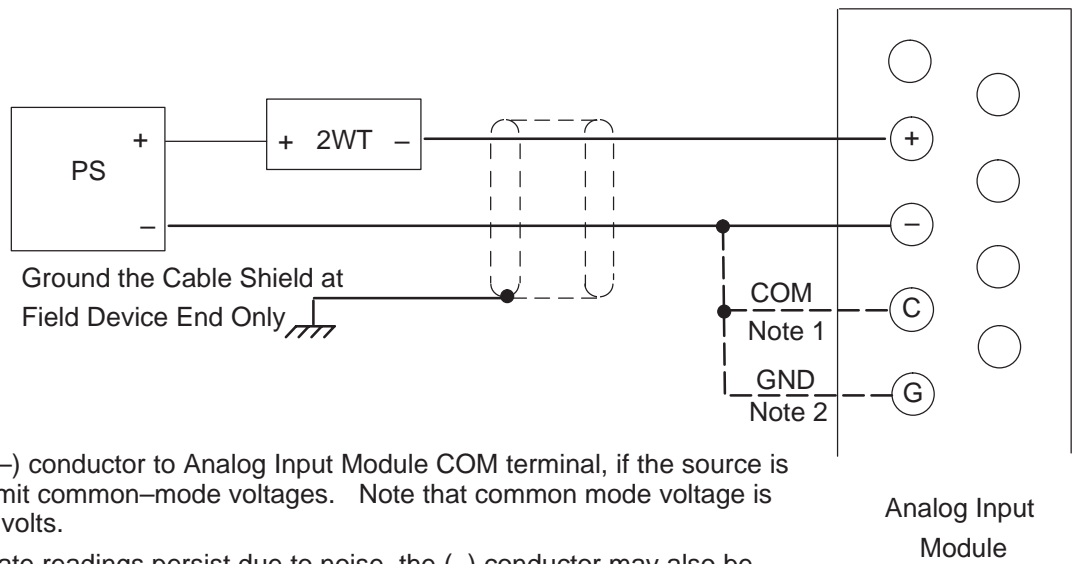

NOTES:

1. Connect (-) conductor to Analog Input Module COM terminal, if the source is floating, to limit common-mode voltages. Note that common mode voltage is limited to 11 volts.
2. If inaccurate readings persist due to noise, the (-) conductor may also be connected to the Analog Input Module GND terminal.

Figure 2-19. 2-Wire Transducer, Externally Powered via DC Supply

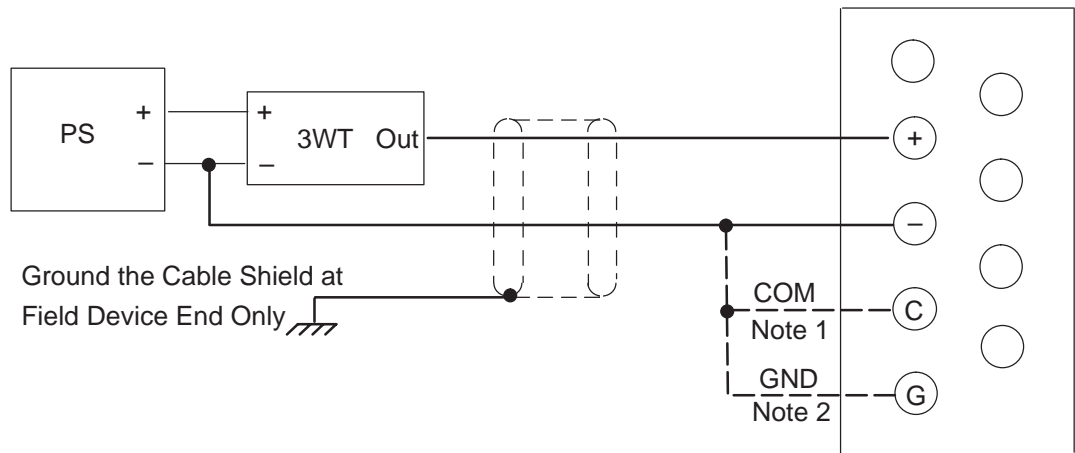

NOTES:

1. If the source is floating, connect (-) conductor to Analog Input Module COM terminal to limit common-mode voltages. Note that common mode voltage is limited to 11 volts.
2. If inaccurate readings persist due to noise, the (-) conductor may also be connected to the Analog Input Module GND terminal.

Figure 2-20. 3-Wire Transducer, Externally Powered via DC Supply

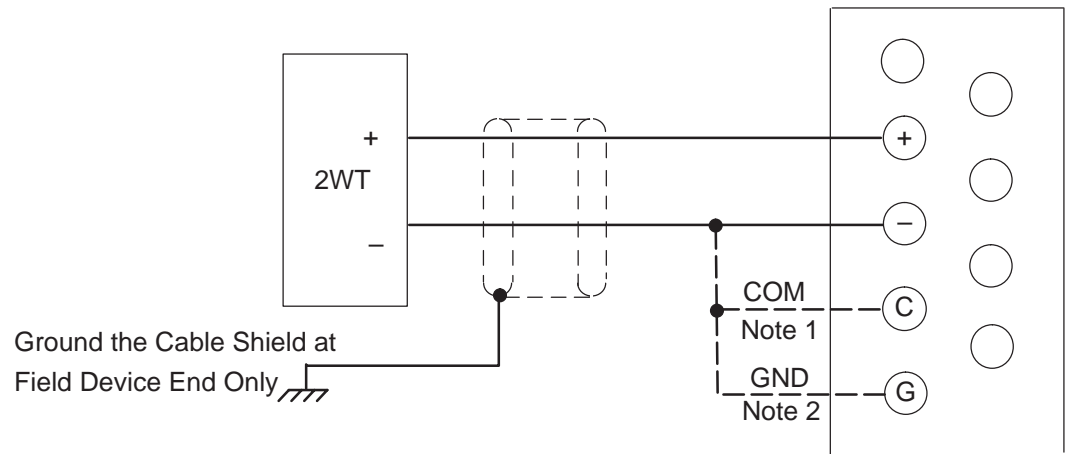

NOTES:

1. If the source is floating, connect (-) conductor to Analog Input Module COM terminal to limit common-mode voltages. Note that common mode voltage is limited to 11 volts.
2. If inaccurate readings persist due to noise, the (-) conductor may also be connected to the Analog Input Module GND terminal.

Figure 2-21. 2-Wire Transducer, Self Powered

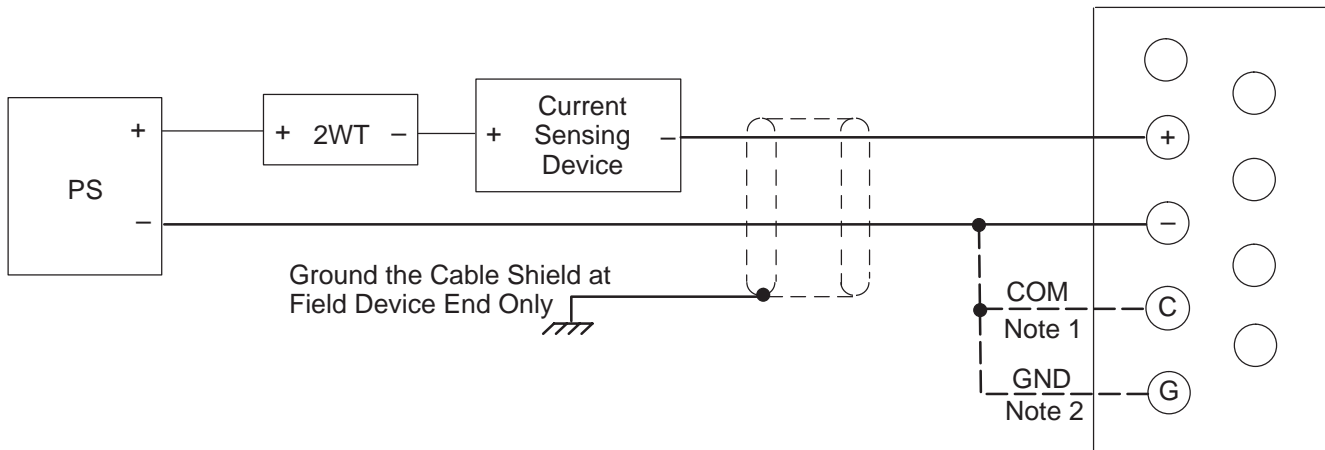

NOTES:

1. If the source is floating, connect (-) conductor to Analog Input Module COM terminal to limit common-mode voltages. Note that common-mode voltage is limited to 11 volts.

2. If inaccurate readings persist due to noise, the (-) conductor may also be connected to the Analog Input Module GND terminal.

CAUTION: The Analog Input Module must be the last device in the circuit. When grounding the (-) return side of the Analog Input Module, the other current sensing device must be floating and able to withstand a common mode voltage of at least 10 volts, including the noise level.

Figure 2-22. 2-Wire Transducer Connected to Two Measuring Devices

Verifying Analog Input Current

Series 90-30 Analog Current Input Modules have an internal 250 ohm resistor across the input terminals. You can measure the voltage across the input terminals using a volt meter, then use Ohm's Law to determine the input current:

$$\text{Input Current (in Amps)} = \text{Volts} / 250$$

For example, if you measured 3 volts across the input terminals:

$$\text{Input Current (in Amps)} = \text{Volts} / 250$$

$$\text{Input Current (in Amps)} = 3/250$$

$$\text{Input Current (in Amps)} = .012 \text{ (which equals 12 mA)}$$

Analog Output Module Wiring

General Analog Output Wiring Methods

Each output should be connected using a good quality shielded wire with the cable shield grounded at the module end. See Chapter 9 for more information.

Using Generic Terminal Block or Strip

- Mount a terminal strip inside the control enclosure and run a shielded cable from the terminal strip to each output circuit on the module's terminal board terminals.
- Ground each cable's shield at the module end to a single GND terminal on the module's terminal board. Connect each cable shield to its own terminal on the terminal strip.
- Wire the field device to the terminal strip with shielded cables, connecting each shield to the terminal that has the corresponding shield for the cable that connects to the module terminal board. Using this arrangement, the shields are "carried through" the terminal strip. (This is illustrated in the section "Analog Output Shield Grounding Example Three.") Also, keep the length of exposed (outside of shield) leads at the terminal strip and device ends as short as possible.

Direct Method

- Run a shielded cable from each field device (transducer, potentiometer, etc.) directly to the module.
- Connect the conductors to the applicable screws on the module's terminal board.
- Ground the shield at the module end only, exposing a minimum amount of conductor to the noisy environment. Do not connect the shield at the device end (cut shield off at device end of cable and insulate with shrink tubing).

TBQC Not Recommended for Analog Modules

The Terminal Block Quick Connect (TBQC) Assembly is not recommended for use with analog modules due to cable shielding requirements.

Analog Output Shield Grounding Example One

For analog output modules, the shield is normally grounded at only the source end (the module) as shown in Figure 3-9. The GND connection provides access to the baseplate (frame ground) resulting in superior rejection of noise caused by any shield drain currents. In extreme noise environments, you can connect a ground braid from the GND terminal to an external earth ground to bypass noise around the module (see “Analog Output Shield Grounding Example Two”).

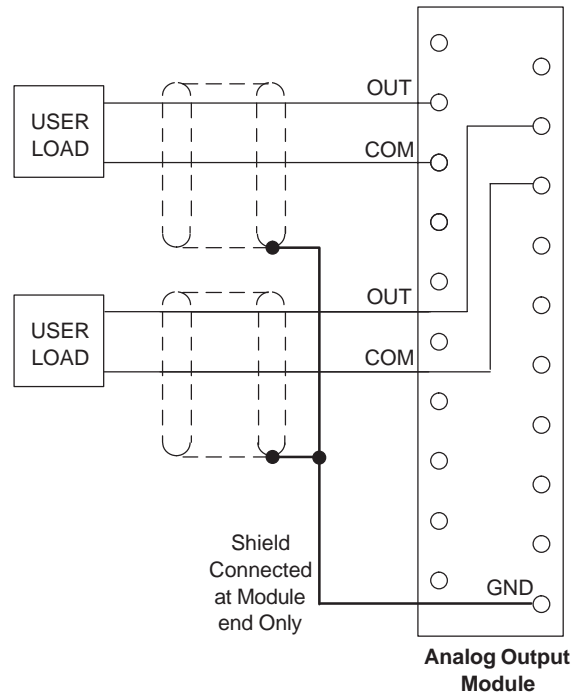

Figure 2-23. Shield Connections for Analog Output Modules

Analog Output Shield Grounding Example Two

This method uses the same scheme as the previous suggestion, but with the addition of an external ground connection to help channel noise around the module.

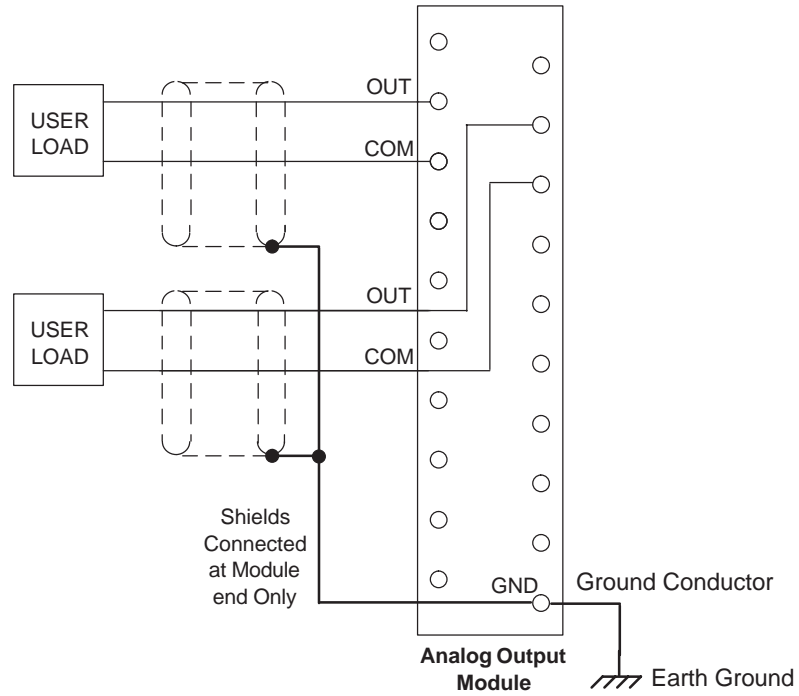

Figure 2-24. Analog Output Module with External Earth Ground Connection

Analog Output Shield Grounding Example Three

If using a terminal strip between the analog output module and the field devices (user loads), use the method in the following figure for grounding the cable shields. Note that each cable is only grounded at one end – the end closer to the Analog Output Module. An optional external ground connection to the output module’s GND terminal is shown for installations that require extra noise suppression.

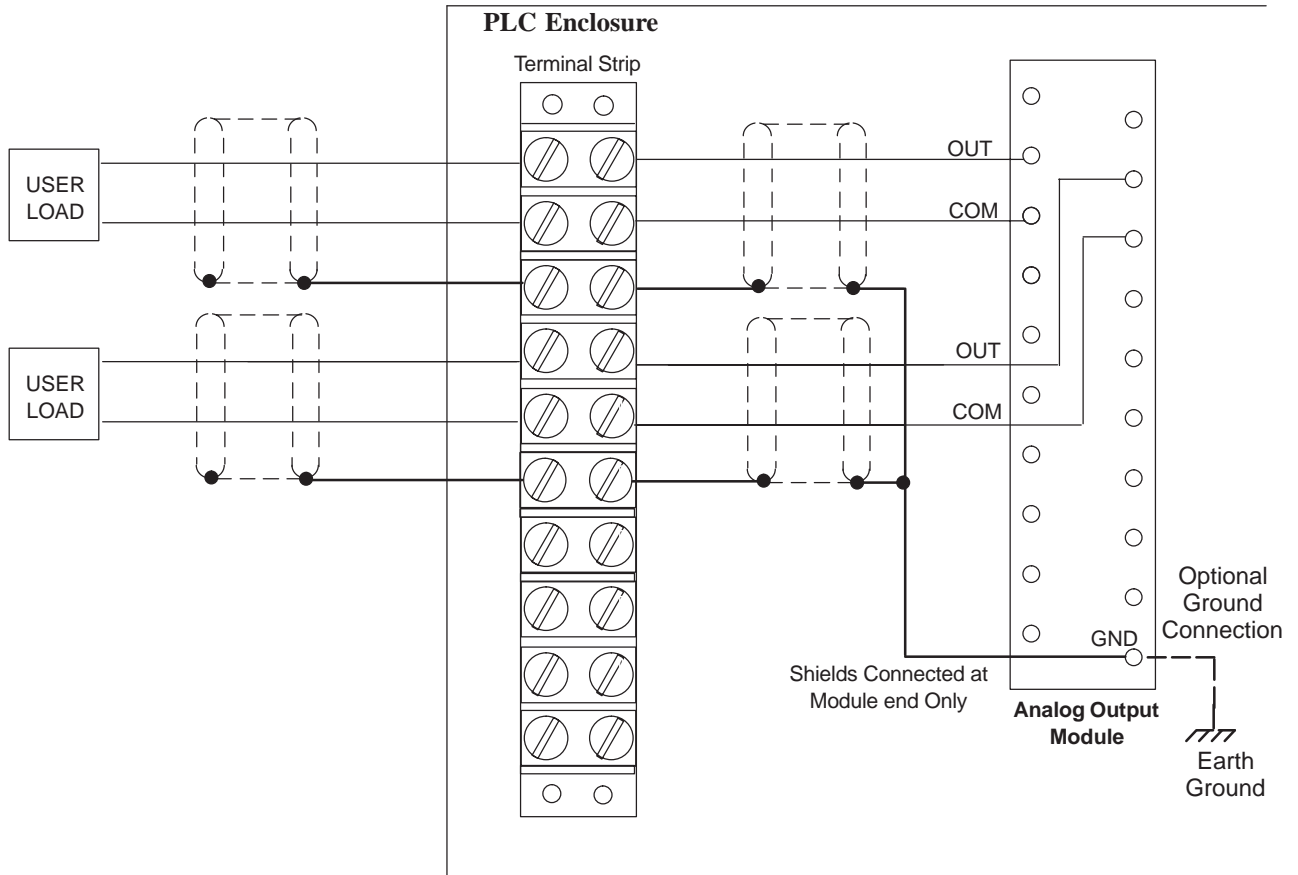

Figure 2-25. Analog Output Shield Grounding when Terminal Strip is Used

AC Power Source Connections

AC Input Wiring to AC/DC Power Supplies

Warning

If the same AC power source is used to provide AC power to other baseplates in a Series 90-30 PLC System, ensure that all AC input connections are identical at each rack. Do not cross Line 1 (L1) and Line 2 (L2). A resulting difference in potential can injure personnel or cause damage to equipment. Each baseplate must be connected to a common ground.

Ensure that the protective cover is installed over all terminal boards. During normal operation with an AC power source either 120 VAC or 240 VAC is present on the AC Power Supply. The cover protects against accidental shock hazard which could cause severe or fatal injury to the operator or maintenance personnel.

Both the Standard (IC693PWR321) and High Capacity (IC693PWR330) AC/DC power supplies currently have six terminals for user connections. Early versions of some Series 90-30 power supplies had five terminals (see next figure). The wiring methods for both five-terminal and six-terminal types is similar, except that step 3 below does not apply to the five-terminal type.

The power supply terminal boards will accept one AWG #14 (2.1 mm²) or two AWG #16 (1.3 mm²) copper 75° C (167° F) wires. Each terminal can accept solid or stranded wires, but the wires in any given terminal should be the same type. The suggested torque for the power supply terminal board is 12 in-lbs (1.36 Newton-meters). Open the door protecting the terminal board and make the following connections from the AC power source, and ground connections (system grounding requirements are described in detail later in this chapter).

1. These are wide range supplies that can operate from an AC power source within the nominal range of 100 VAC to 240 VAC at 50/60 Hz. This may vary -15% to +10% for a total maximum range of 85 VAC to 264 VAC. These are auto-ranging supplies that do not require jumper or switch settings for selection of power source voltage.
2. Connect the hot and neutral wires or lines L1 and L2 to the upper two terminals on the terminal board. Connect the safety ground wire to the ground terminal, which is the third terminal from the top, and is marked with a ground symbol.
3. For power supplies with six terminals, the factory jumper between the 3rd and 4th terminals (see figure below), should be left in place for normal installations. However, this jumper must be removed and external surge suppressors installed in installations with a "Floating Neutral" input. Please see the section "Special Instructions for Floating Neutral (IT) Systems" later in this chapter for details.
4. After all connections to Power Supply terminal board have been completed, the protective cover plate should be carefully reinstalled.

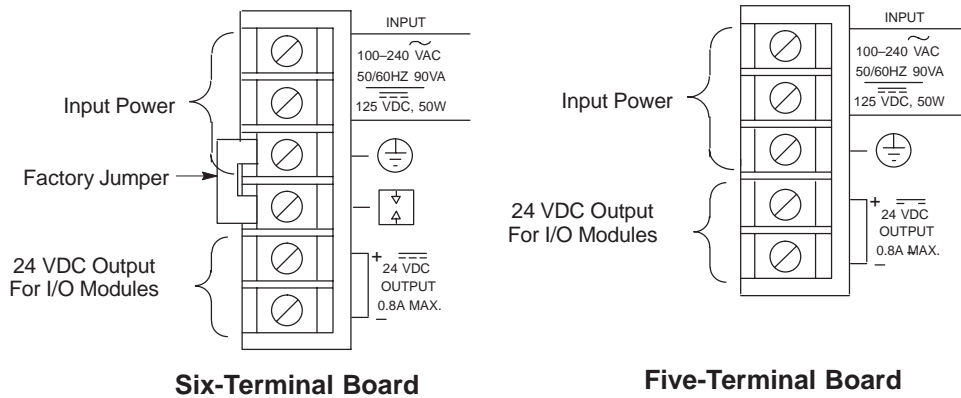

Figure 2-26. Power Supply Terminal Boards

Power Supply Overvoltage Protection Devices

On power supplies with six-terminal boards, the overvoltage protection devices are connected internally to pin 4 of the terminal board. This pin is normally connected to frame ground (pin 3) with the supplied jumper strap which is installed at the factory. If overvoltage protection is not required *or* is supplied upstream, this feature can be disabled by removing the jumper strap. Also, this jumper must be removed and external surge suppressors installed in installations with a “Floating Neutral” input (please see the following section “Special Instructions for Floating Neutral (IT) Systems”).

If you want to Hi-pot test this supply, overvoltage protection *must be disabled* during the test by removing the terminal board jumper strap. Re-enable overvoltage protection after testing by reinstalling the strap.

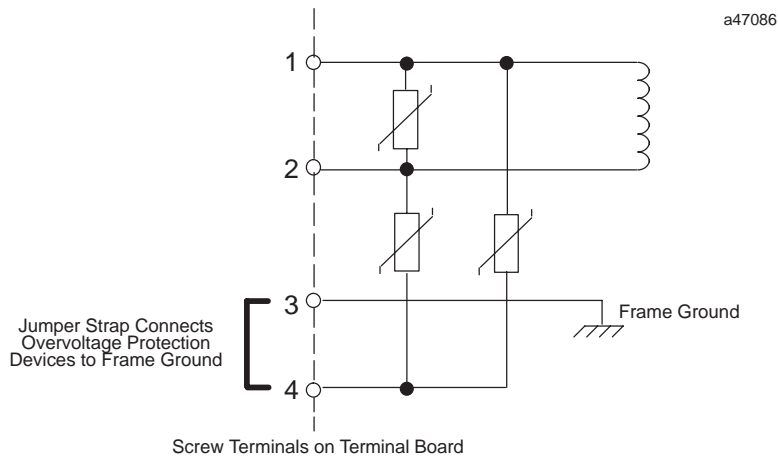

Figure 2-27. Overvoltage Protection Devices and Jumper Strap

Special Installation Instructions for Floating Neutral (IT) Systems

When the AC input power supplies listed below are installed in a system where the Neutral line is **not** connected to Protective Earth Ground, these special installation instructions must be followed to prevent damage to the power supply.

- IC693PWR321S (or later version)
- IC693PWR330A (or later version)

Definition of Floating Neutral Systems

A *Floating Neutral System* is a system of power distribution wiring where Neutral and Protective Earth Ground are **not** tied together by a negligible impedance. In Europe this is referred to as an **IT** system (see IEC950). In a *Floating Neutral System*, voltages measured from input terminals to protective earth ground may exceed the 264 Volts AC maximum input voltage specified in the power supply specifications in this manual.

Example of Floating Neutral System

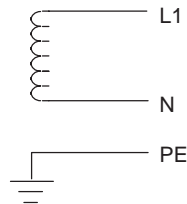

This system **must** be installed using the special installation instructions on the following page.

Systems in which one leg of the power distribution wiring is tied to Protective Earth or a tap between two legs of the power distribution wiring is tied to Protective Earth are **not** *Floating Neutral Systems*.

Examples of Non-Floating Neutral System

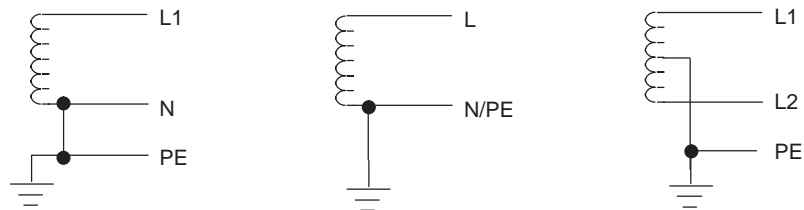

These non-floating neutral systems **do not** require these special installation instructions.

Use These Special Installation Instructions for Floating Neutral Systems

1. The input power terminals should be wired according to the instructions in the “AC Power Source Connections” section of this chapter.
2. The factory installed jumper between terminals 3 and 4 of the Power Supply module **must** be removed if using one of the Power Supplies that have this feature. See the “Overvoltage Protection Devices” section of the “Power Supplies” chapter for details.
3. Voltage surge protection devices, such as MOVs, **MUST** be installed between the following terminals:
 - From L1 to earth ground
 - From L2 (Neutral) to earth ground

The voltage protection devices must be rated such that the system is protected from power line transients that exceed the level calculated in the following formula:

$$\text{Line voltage} + 100V + (N-PE)_{MAX}$$

The expression $(N-PE)_{MAX}$ refers to the maximum voltage potential between neutral and Protective Earth (PE) ground.

For example, in a 240 Volt AC system with neutral floating a maximum of 50V above earth ground, the transient protection should be rated at:

$$240V + 100V + (50V) = 390V$$

DC Power Source Connections

DC Input Wiring to all Series 90–30 Power Supplies

All Series 90-30 power supplies have DC input capabilities. The following connection information applies to all of them:

Connect the + wire from the power source to the top terminal on the terminal board, and connect the – wire to the second terminal (from the top). Connect the third terminal from the top to system ground. See the examples in the following figure:

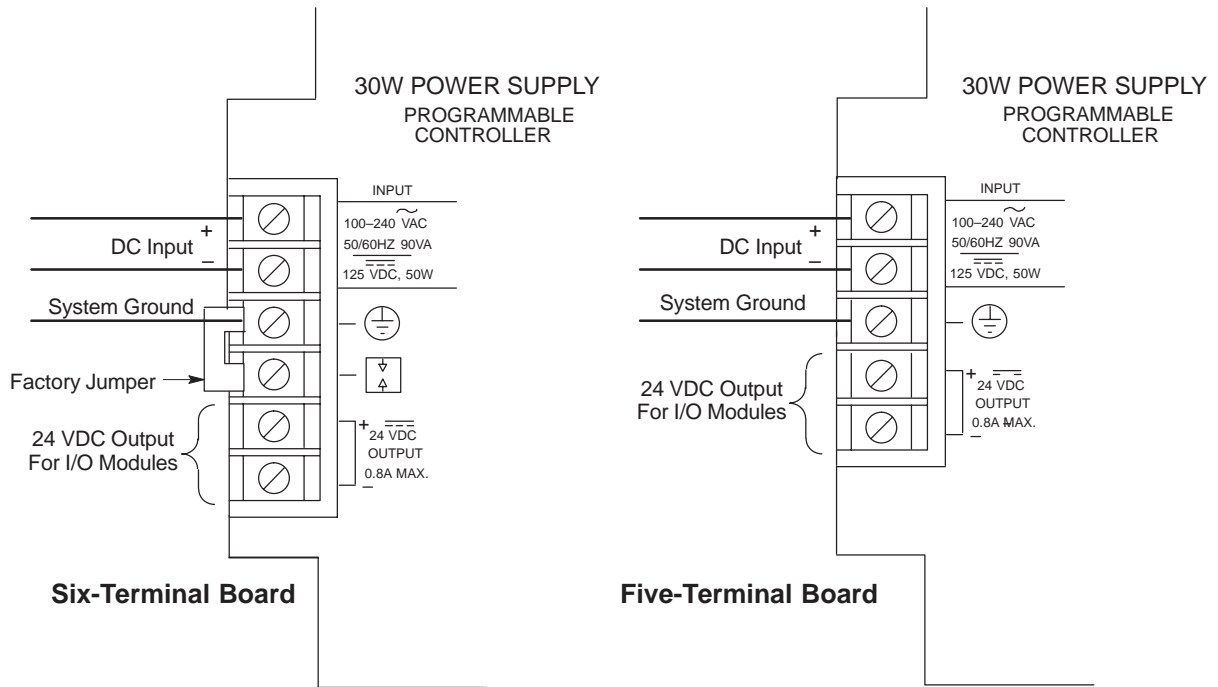

Figure 2-28. DC Input Wiring Examples

+24 VDC Output (All Supplies)

The bottom two terminals are connected to the isolated 24 volt DC output that can be used to supply power to input/output circuits (within power limitations of the supply).

Warning

If the same DC input power source is used to provide power to two or more power supplies in a Series 90-30 PLC System, ensure that connection polarity is identical at each rack (top terminal + and second terminal –). Do not cross the Positive (+) and Negative (–) lines. A resulting difference in potential can cause injury to personnel and damage to equipment. Also, each baseplate must be connected to a common system ground, described earlier in this chapter.

Basic Installation Procedure

The system design, which includes producing the layout and wiring drawings, should be completed before beginning the installation procedure. This section offers a basic step-by-step approach to installing a Series 90-30 PLC system. Some steps refer to earlier sections of this chapter for additional details. An attempt was made to place the steps in an order that will make the process as efficient as possible. However, due to the wide variance in system designs, this order may not be the most efficient for your system, so you may wish modify this procedure to fit your needs.

1. Gather the schematics, layouts, prints, and other information for the job.

Warning

To avoid the possibility of electrical shock to personnel or damage to your PLC, we recommend that you shut off all power to the system before mounting and wiring the PLC. Also, keep all electronic components away from the area while drilling and tapping to keep metal chips and filings out of these sensitive components.

2. From the layout drawing, determine where the baseplate(s) will be mounted. Lay out the hole locations, either using the dimensions given on your layout drawing or from the “Baseplates” chapter of this manual.
3. Mark the hole location for the baseplate safety ground wire (see “Baseplate Safety Ground” in this chapter).
4. Mark the hole locations for module shield ground connections (if any). See the section “Module Shield Ground” in this chapter for instructions.
5. Finish marking hole locations for the rest of the system. This includes any terminal blocks you will be using. DIN-rail mounted terminal blocks for some of the 32-point I/O modules are manufactured by Weidmuller. DIN-rail mounted GE Fanuc Terminal Block Quick Connect (TBQC) assemblies are optional for some of the 16-point and 32-point discrete I/O modules. If using these TBQCs, refer to Appendix D for data. Also, APM and DSM modules use optional DIN-rail mounted terminal blocks.

Note

We recommend drilling and tapping all holes before mounting any components. This will avoid getting chips and filings in the components.

6. Drill and tap the marked holes. For baseplate mounting, holes should be 8-32 or 4mm size.
7. Mount the baseplates using 8-32 x 1/2 inch or 4 x 12mm size screws. Always use good quality (corrosion resistant) mounting hardware. We recommend using star lock washers and flat washers under the screw heads (star lock washer should be located between screw head and flat washer) to ensure a tight baseplate ground connection, and to keep the screws from loosening. Connect each baseplate ground wire as shown in the “Baseplate Safety Ground” section of this chapter.
8. If you have Expansion or Remote racks, determine the correct rack number for each one, then set the rack numbers using the Rack Number Selection DIP switch on the baseplate. Please refer to the “Baseplates” chapter for details on setting these DIP switches. Rack numbers should be assigned by the system programmer because they correspond to system configuration settings and program memory addressing.

9. If you have more than one baseplate (rack), interconnect the baseplates with I/O Bus Expansion Cables. These connect between the I/O Bus Expansion Connectors, which are located on the right end of the baseplates. These cables are connected in a “daisy-chain” arrangement from one baseplate to the other. This is made possible by the fact that the cables have a dual connector on one end. Therefore, when the cable is plugged into an I/O Bus Expansion connector, the second connector on that end of the cable provides a socket for connecting to the next cable. The data sheet for the I/O Bus Expansion cables (IC693CBL300 etc.) in Appendix C has sample wiring figures.
10. On the last I/O Bus Expansion Connector, plug in an I/O Bus Expansion Terminator, Catalog Number IC693ACC307 (unless using a cable with built-in terminator resistors, which would either be GE Fanuc cable IC693CBL302, IC693CBL314, or your own custom-built cable with built-in resistors).
11. Install the modules in their correct slots using your system layout drawings. (The label on the side of each module identifies the module type and catalog number.) Refer to the section “Installing Modules” if you are not familiar with how to do this.
12. Connect cables to Option modules. Route cables away from noise-producing wires. See the “Wire Routing” section of this chapter.
13. Be sure to follow the information in the “General Wiring Guidelines” section of this chapter to protect the system from electrical noise. Use the applicable wire color-coding scheme referred to in that section. Install the power wires to the Power Supply and I/O modules:
 - **I/O modules with removable terminal boards.** You can wire the terminal boards in-place on the modules or remove them from the modules before wiring. Although removing them may help make wiring easier (a previous section “Working with Removable Terminal Boards” shows how to remove a terminal board), care should be taken to avoid mixing them up and installing them on the wrong module (each terminal board has the catalog number of the module printed on it, and the hinged cover has a wiring diagram for that module type). If you are using wire duct, routing each module’s wires through the opening in the duct directly under the module will help to keep each terminal board in its correct position and thus avoid its being installed on the wrong module.
 - **I/O Modules with terminal blocks.** Some modules may use optional terminal blocks that mount to the enclosure panel. This includes all 32-point modules and, can include other I/O modules if they are fitted with the optional Terminal Block Quick Connect Assembly. Connect the terminal blocks to the connectors on the modules with the correct cables.
14. Connect the signal (switches, sensors, solenoids, etc.) wires to the terminal boards, or terminal blocks/strips. (If wiring to module terminal boards, these can be removed for ease of wiring if desired. See the section “Removing a Module’s Terminal Board” in this chapter.)
15. When finished wiring any I/O terminal boards (if you removed them from the I/O modules for ease of wiring), re-install them on the modules, being careful to match each one with the correct module.

Chapter 3

Series 90–30 Baseplates

efesotomasyon.com

Baseplate Types

A baseplate is composed of three main parts: (1) a circuit board mounted to (2) a metal back-plate with (3) a plastic cover. The circuit board, called the "backplane," contains sockets for plug-in modules. The metal back-plate has four holes for mounting the baseplate, and retainer slots for mounting the modules. The plastic cover provides protection for the circuit board, slotted holes for the module connectors and retainers, and printed labels such as the baseplate description, serial number, and slot number labels. There are three basic types of baseplates discussed in this chapter:

- CPU
- Expansion
- Remote

Common Baseplate Features Illustrated

The callouts in the following picture show the items that are common to all Series 90-30 baseplates. Note that a modular CPU baseplate is shown.

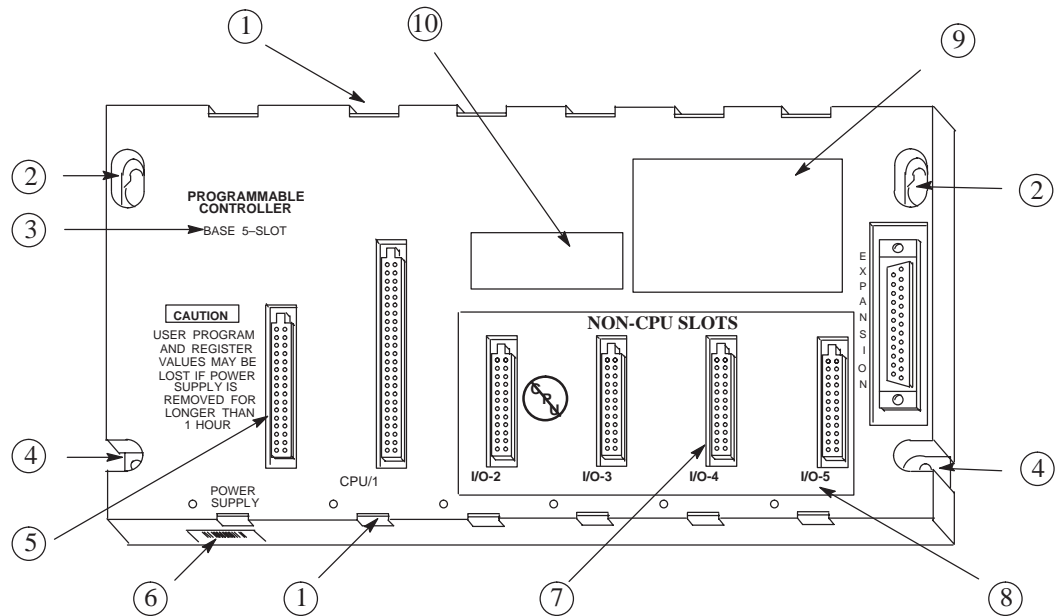

1. Module retainers
2. Upper mounting holes
3. Baseplate description
4. Lower mounting holes. The plastic cover is slotted at these two holes to facilitate a ground connection. See the “Baseplate Safety Grounding” section of the “General Installation Guidelines” chapter for ground connection details.
5. Backplane connector for Power Supply
6. Serial number label
7. Backplane connectors for I/O or Option modules (slots 2–4) . Note that the slot labeled CPU/1 is the backplane connector for a CPU module; however, on Embedded CPU, Expansion, and Remote baseplates, this would be another I/O or Option module slot.
8. Slot labels. May show just the slot number, or may show type (CPU or I/O) and number.
9. Compliance label
10. Catalog number and certification (UL, CE, etc.) label. On an Embedded CPU baseplate, this label will be located between Slots 4 and 5.

Figure 3-1. Common Baseplate Features

Two Baseplate Sizes

Series 90-30 baseplates come in two sizes: 5-slot and 10-slot. Be aware that the Power Supply slot is not numbered, and it is not considered to be one of the 5 or 10 slots. So a 5-slot baseplate has slots for a Power Supply and five other modules, and a 10-slot baseplate has slots for a Power Supply and ten other modules.

Baseplate Terms Explained

Backplane: Refers to the circuit board in the baseplate. It contains the baseplate circuitry and sockets for the plug-in modules.

Rack: This term applies to an assembly consisting of a baseplate, power supply, and other modules.

Rack Number: In systems that require more than one rack, each rack is given its own unique number, which enables the CPU to distinguish one rack from another.

Slot Number: Each module location (called a "slot") on a baseplate has a unique number (except for the unnumbered left slot which is for the Power Supply). The slot to the right of the Power Supply slot is always called Slot 1. These slot numbers are marked on the baseplate's plastic cover. Each slot has a connector for module connections and top and bottom retainers for holding the module in place.

Module Location: Since each rack is assigned a unique number, and since each slot in a rack's baseplate has a unique slot number, each individual module's location in a system can be identified by its rack and slot numbers. For example, a module could be referred to as "the module in Rack 1, Slot 4." This numbering method enables the CPU to correctly read from and write to a particular module, and report the location of a faulted module.

CPU Baseplate: A baseplate that either has a CPU built-in to its backplane circuit board (embedded CPU) or one that has a slot for a plug-in CPU module (modular CPU). There can only be one CPU baseplate in a Series 90-30 PLC system and it will always be called Rack 0 (zero). A CPU module can only mount in Slot 1 of a CPU baseplate. A special Option module, such as the FIP Remote I/O Scanner module (IC693BEM330) can also be used in Slot 1 of a CPU baseplate. I/O, Power Supply, and most Option modules cannot fit in a CPU slot.

Expansion Baseplate: One that does not contain a CPU and which can be mounted up to 50 cable-feet from the CPU baseplate. An Expansion baseplate cannot operate on its own. It must be used in a system that has a controlling CPU.

Remote Baseplate: One that does not contain a CPU and which can be mounted up to 700 cable-feet from the CPU baseplate. A remote baseplate cannot operate on its own. It must be used in a system that has a controlling CPU.

Power Supply Slot: Each baseplate must contain its own Power Supply module, which must mount in the Power Supply slot. It is the slot located on the left end of the baseplate, it is not numbered, and it has a unique size and shape so that only a Power Supply module can mount in it.

Note

Attempts to force a module into an improper slot type will result in damage to the module and/or the baseplate. Modules will mount in the correct slot type easily and with a minimum of force.

CPU Baseplates

There are two basic kinds of CPU baseplates, embedded and modular. The embedded types fulfill the need for a good low cost PLC, but lack the power, expandability, and versatility of the modular systems.

Embedded CPU Baseplate: This type has CPU and memory integrated circuit chips soldered to its backplane circuit board.

Modular CPU Baseplate: This type does not have CPU and memory chips on its backplane. Instead, it has a connector in Slot 1 for a plug-in CPU module which contains the CPU and memory chips on an internal circuit board.

Embedded CPU Baseplates (Figures 3-2 and 3-3)

There are three models of embedded baseplates, the 311, 313, and 323. These model numbers are based upon the CPU type that each contains. This chapter discusses only the baseplate features of these products. CPU specifications for the embedded CPU are located in Chapter 4. The embedded CPU baseplates have the following features:

- The CPU type cannot be changed.
- They do not support the use of expansion or remote racks, so these racks do not have an expansion connector like the modular CPU baseplates do.
- The models 311 and 313 are 5-slot baseplates, and the model 323 is a 10-slot baseplate.
- Since they do not require a plug-in CPU module, all numbered slots, including Slot 1, can be used for I/O or Option modules.
- The memory back-up battery is located in the Power Supply module; so if the Power Supply is unplugged from the baseplate, the battery will be disconnected from the memory circuits, which are located on the backplane circuit board. However, the backplane circuit board contains a high value capacitor, sometimes called a "super capacitor," that can store enough charge to maintain the memory circuits for about 1 hour if the Power Supply is removed or its battery is disconnected. For additional details on this subject, please see Chapter 6 of the *Series 90-30 PLC Installation and Hardware Manual*, GFK-0356P (or later version).
- There are no configuration switches or jumpers on the Model 311, 313, or 323 baseplates.
- An embedded CPU baseplate is always assigned, by default, Rack Number Zero (0).

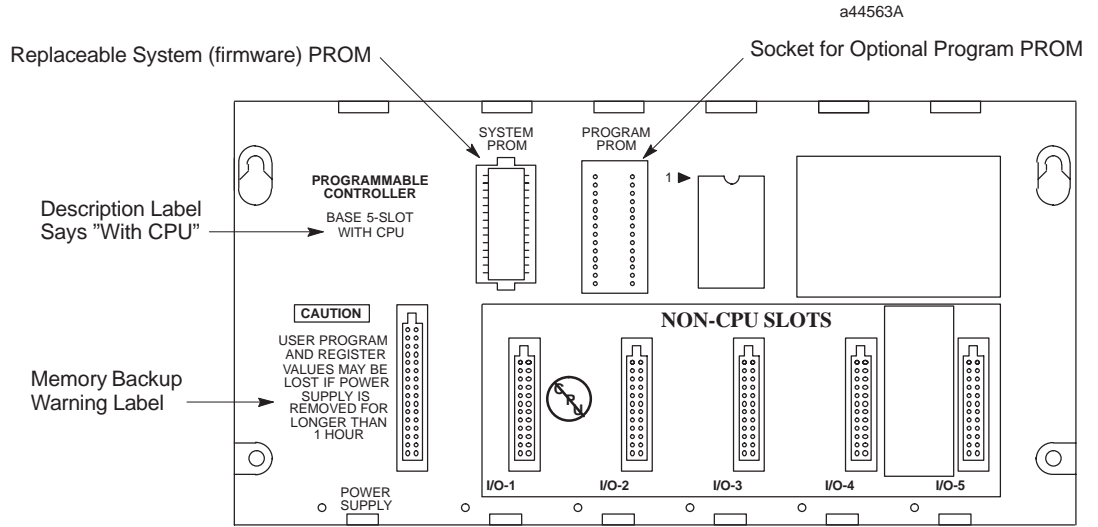

Figure 3-2. IC693CPU311 and IC693CPU313 5-Slot Embedded CPU Baseplates

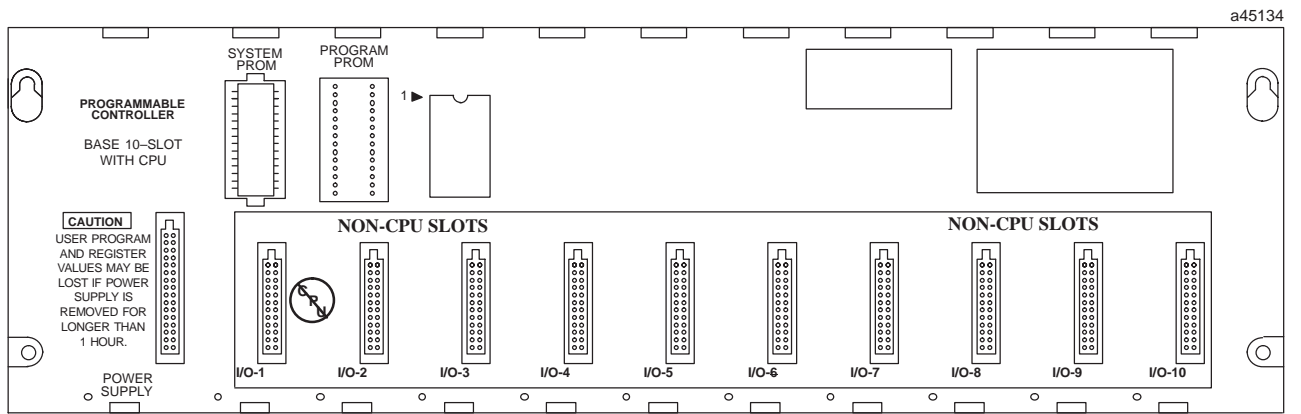

Figure 3-3. IC693CPU323 10-slot Embedded CPU Baseplate

Modular CPU Baseplates (Figures 3-4 and 3-5)

- A Power Supply module must be plugged into the left slot (which is not numbered) of these baseplates. The left slot is a unique size and type that only supports a Power Supply module.
- A CPU module (or a special Option module) must be installed in Slot 1 of these baseplates. Slot 1 is a unique size and type that only supports a CPU module or a special Option module like the FIP Remote I/O Scanner (IC693BEM330). Slot 1 is labeled CPU/1.
- Slots numbered 2 and above are of a unique size and type that only supports I/O or Option modules.
- Expansion and Remote baseplates are supported, so a 25-pin D-type female expansion connector is located at the right end of the baseplate for connecting to an Expansion or Remote baseplate.
- Since the CPU is modular, it can be replaced or changed to a different type if additional features are desired.
- Only one CPU baseplate is allowed per system. If more than one baseplate is used in a system, the additional ones must be either Expansion or Remote types.
- A modular CPU baseplate is always assigned, by default, Rack Number 0.

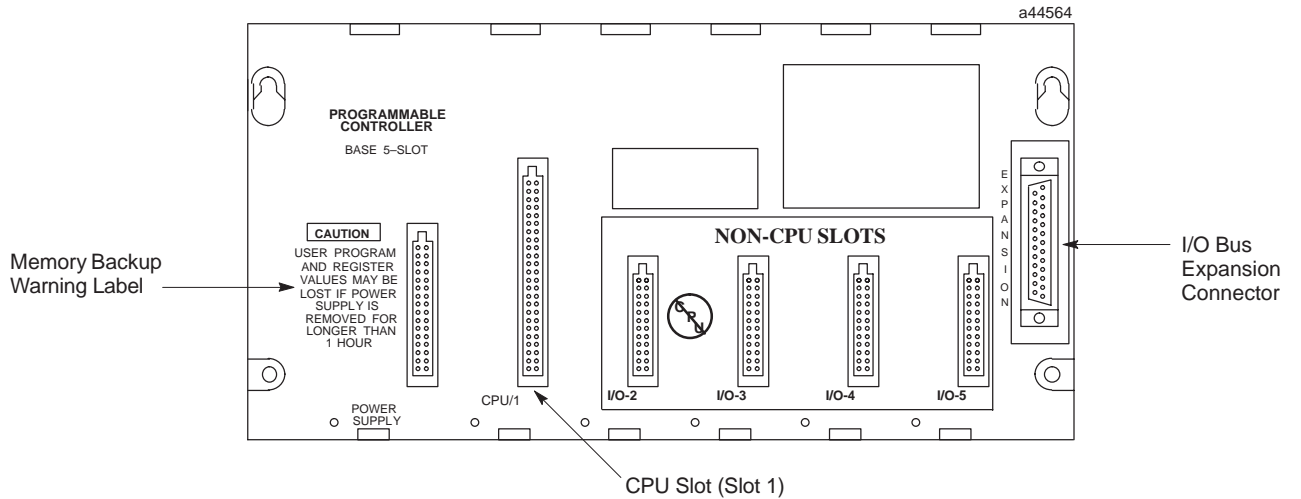

Figure 3-4. IC693CHS397 5-Slot Modular CPU Baseplate

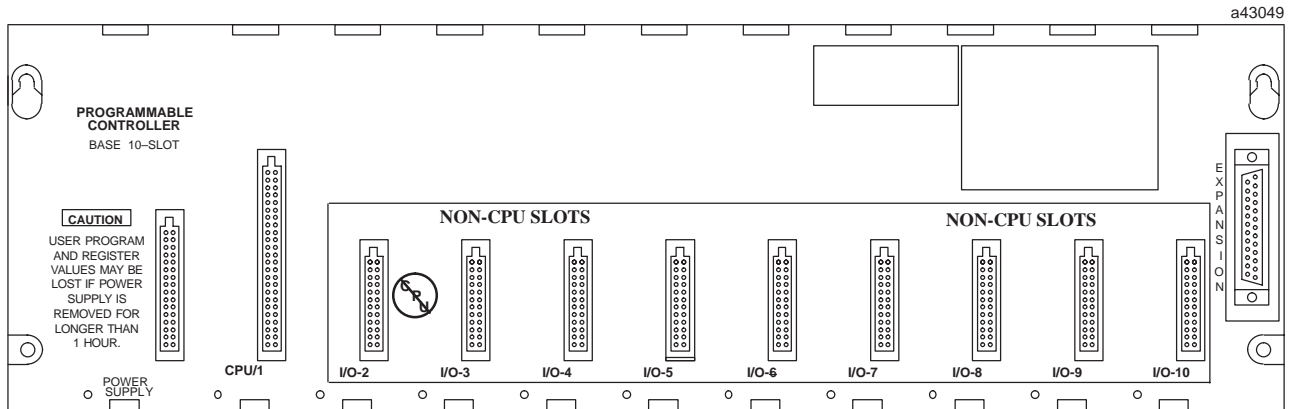

Figure 3-5. IC693CHS391 10-Slot Modular CPU Baseplate

Expansion Baseplates (Figures 3-6 and 3-7)

- There can be **no more** than a total of 50 feet (15 meters) of cable interconnecting Expansion baseplates and the CPU baseplate.
- An Expansion baseplate cannot stand alone. It must be connected to a system that has a CPU. The CPU can be in a PLC or in a Personal Computer that is equipped with a Personal Computer Interface Card (see Chapter 11).
- Maximum number of Expansion baseplates allowed per system depends on the type of CPU they are used with. For CPUs 331, 340, and 341, the maximum is 4. For CPUs numbered 350 and higher, the maximum is 7.
- Each Expansion baseplate has a 25-pin female D-type I/O Bus Expansion connector mounted at its right end for connection to other baseplates.
- Available in two versions; 5-slot (IC693CHS398) and 10-slot (IC693CHS392)
- An Expansion backplane does not support the following intelligent option modules: PCM, ADC, BEM330, and CMM. These modules must be mounted in a CPU baseplate. All other I/O and option modules can be mounted in any type of rack.
- All Expansion baseplates must be connected to a common ground (see the "Installation" chapter for details).
- Expansion baseplates are the same physical size, use the same type power supplies, and support the same I/O and option modules as the Remote baseplates.
- Each Expansion baseplate has a Rack Number Selection DIP switch.

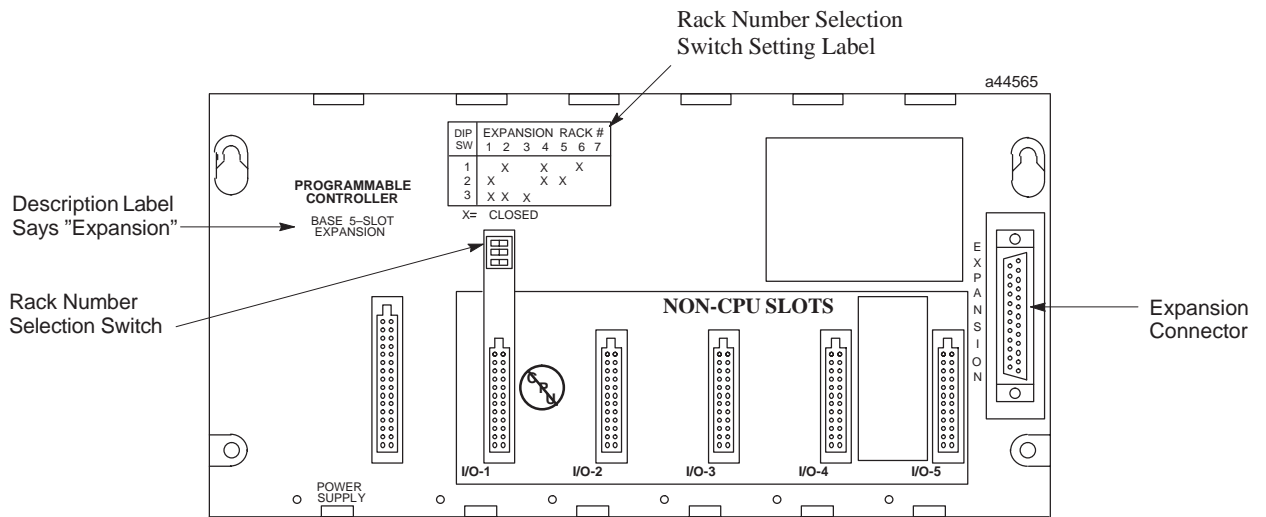

Figure 3-6. IC693CHS398 5-Slot Expansion Baseplate

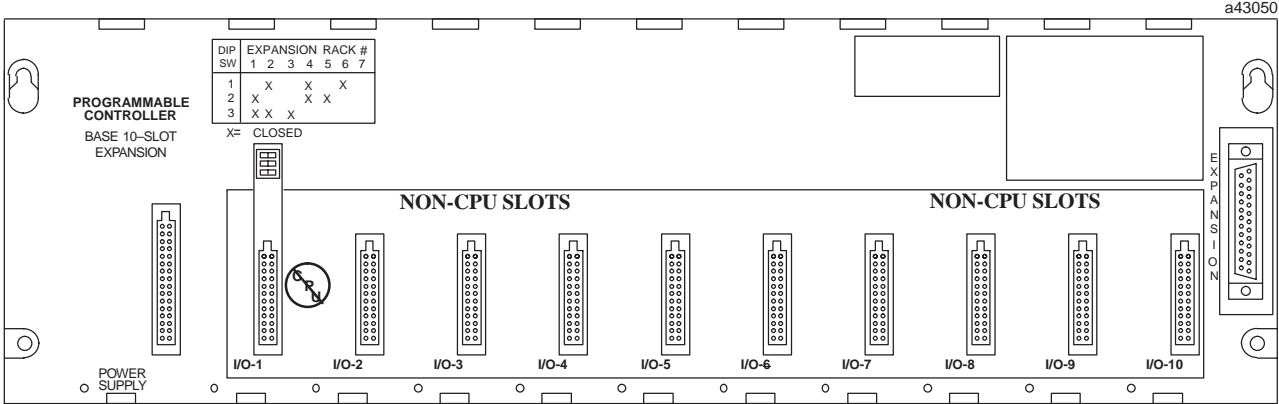

Figure 3-7. IC693CHS392 10-Slot Expansion Baseplate

Remote Baseplates (Figures 3-8 and 3-9)

- There can be no more than 700 feet of cable connecting all baseplates in a system that uses Remote baseplates.
- A Remote baseplate cannot stand alone. It must be connected to a system that has a CPU. The CPU can be in a PLC or in a Personal Computer that is equipped with a Personal Computer Interface Card (see Chapter 11).
- Remote capability is facilitated by the Remote baseplate’s built-in isolation between the +5 volt logic supply used by the I/O modules residing in the Remote baseplate and the supply for the interface circuit associated with the I/O Bus Expansion Interface. Isolation helps prevent problems associated with unbalanced ground conditions.
- Maximum number of Remote baseplates allowed per system depends on the type of CPU they are used with. For CPUs 331, 340, and 341, the maximum is 4. For CPUs numbered 350 and higher, the maximum is 7.
- Each remote baseplate has a 25-pin female D-type Expansion connector mounted at its right end for connection to other baseplates.
- Remote baseplates are available in two sizes; 5-slot (IC693CHS398) and 10-slot (IC693CHS392)
- A Remote backplane does not support the following intelligent option modules: PCM, ADC, BEM330, and CMM. These modules must be mounted in a CPU baseplate. All other I/O and option modules can be mounted in any type of baseplate.
- Remote baseplates are the same physical size, use the same type power supplies, and support the same I/O and option modules as the Expansion baseplates.
- Each Remote baseplate has a Rack Number Selection DIP switch.

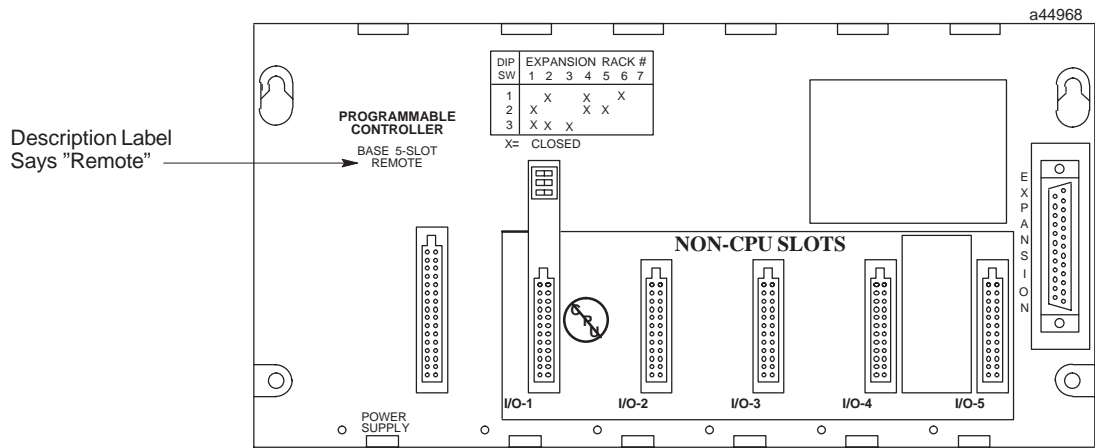

Figure 3-8. IC693CHS399 5-Slot Remote Baseplate

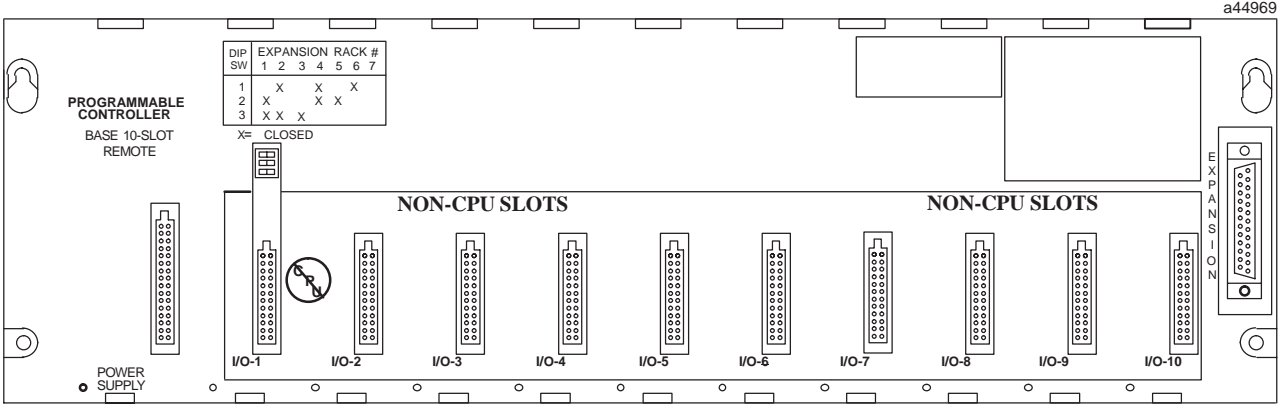
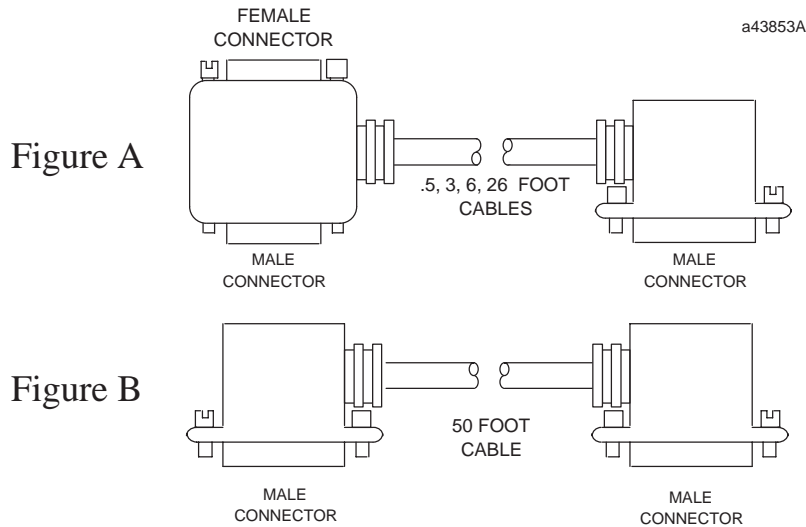

Figure 3-9. IC693CHS393 10-Slot Remote Baseplate

I/O Bus Expansion Cables

Five prewired I/O Bus Expansion cables are available from GE Fanuc. Catalog numbers and lengths of these cables are listed in the following figure. You can build custom cables to suit the needs of your application if cable lengths other than those listed are required. Refer to the “Cables” chapter for detailed information on cable type and connectors. Note that the same cables can be used with both Expansion and Remote baseplates, however the cables used in a remote expansion system *must* use the cable type described in the “Cables” chapter.



Catalog Number	Length	Figure
IC693CBL300	3 feet (1 meter), continuous shield	A
IC693CBL301	6 feet (2 meters), continuous shield	A
IC693CBL302	50 feet (15 meters), continuous shield with built in terminator (this is not a Wye cable)	B
IC693CBL312	0.5 feet (.15 meters), continuous shield	A
IC693CBL313	25 feet (8 meters), continuous shield	A

Figure 3-10. I/O Bus Expansion Cables

Note

The 3 foot cable (IC693CBL300) can be used as a Wye adapter between custom-built cables and Remote baseplates.

Differences Between Remote and Expansion Racks

Basically, Remote racks provide the same functionality as Expansion racks, but with the longer distance (700 feet/213 meters versus 50 feet/15 meters for Expansion racks) capability. To minimize unbalanced ground conditions, Remote baseplates have extra isolation circuitry. Unbalanced ground conditions can occur when systems are located long distances from each

other and do not share the same ground system. However, distance is not always the problem; even racks that are mounted near each other can experience problems if the system is not grounded properly. See Chapter 2 for grounding information.

The use of Remote racks requires a special consideration pertaining to scan time. In order to operate at long distances, the I/O Bus runs at a lower clock speed (compared to that used for Expansion racks) when communicating with Remote racks, which will have an impact on performance. The impact will be relatively small for discrete I/O and slightly more for other modules, such as the High Speed Counter or Genius Communications Module. The increase in time needed to communicate with modules in a remote baseplate will usually be small with respect to the overall scan time. For more detailed information on scan time calculations, refer to Chapter 2 of GFK-0467, the *Series 90-30/20/Micro PLC CPU Instruction Set Reference Manual*.

Another important scan time consideration is the cable type used for communicating at longer distances. Data propagation delay must be minimized to ensure proper system timing and margins. Any deviation in cable type may result in erratic or improper system operation. Suggested cable types are specified in Appendix C in the IC693CBL300/etc. data sheet.

Mixing Expansion and Remote Baseplates in a System

Expansion and remote baseplates can be used in the same system as long as certain requirements are met:

- You do not exceed the 50 foot (15 meter) maximum cable distance from the CPU to the last Expansion baseplate
- You do not exceed the 700 foot (213 meter) maximum cable distance from the CPU to the last Remote baseplate.
- The cable type recommended for use with Remote baseplates must be used throughout the system. The exception to this requirement is that the prewired 3 foot (1 meter) cable, IC693CBL300, can be used as a Wye adapter to simplify the custom cable assembly associated with the “daisy chain” connections between baseplates. Information on building cables for use with Remote baseplates can be found in Appendix C in the IC693CBL300/etc. data sheet..

Termination Requirement for Expansion or Remote System

When two or more baseplates are connected via the I/O Bus Expansion System, the I/O Expansion Bus must be properly terminated. The most common method of terminating the I/O Expansion Bus is by installing a termination resistor pack (IC693ACC307) on the open connector on the last (most distant from the CPU) Expansion or Remote baseplate in the system. The resistor pack is physically mounted inside of a connector. Although a termination resistor pack is shipped with each baseplate, only the last baseplate in the chain needs to have this termination connector installed. Unused termination packs can be discarded. The prewired 50 foot (15 meter) cable (IC693CBL302) has termination resistors wired inside the connector on one end of the cable. This cable can be used if only one expansion rack is needed in a system and a 50 foot cable link is required (the IC693ACC307 resistor pack is not needed in this case). Also, a custom-built cable with built-in resistors would eliminate the need for the IC693ACC307 resistor pack.

Powering Down Individual Expansion or Remote Baseplates

Expansion or Remote baseplates can be powered-down individually without affecting the operation of other baseplates; however, powering off a baseplate generates a loss of module

(LOSS_OF_MODULE) fault in the PLC Fault Table for each module in the powered-down baseplate. When this fault condition occurs, and until the baseplate is powered back on and all modules recovered, the lost I/O modules are not scanned by the CPU. For more information on the power-up and power-down sequence, see Chapter 2 in the *Series 90-30 PLC CPU Instruction Set Reference Manual*, GFK-0467.

Series 90-30 PLC Backplane

The Series 90-30 PLC backplane (on all three types of baseplates) has a dedicated I/O communications bus. The signals on the remote baseplate backplane are optically coupled and an isolated DC-DC power supply converter is provided to isolate the signals from other backplanes.

- **Power bus** – connects the power supply outputs to the modules in the baseplate.
- **I/O Communications bus** – the CPU communicates with I/O modules over this bus. This bus is connected to the I/O busses in Expansion and Remote racks via the I/O Bus Expansion connectors and cables.
- **Special Intelligent Module bus** – exists only on a CPU baseplate; therefore, certain special intelligent option modules, such as the PCM, ADC, and CMM modules, will only work in a CPU baseplate.

Rack Number DIP Switch on Expansion and Remote Baseplates

Each baseplate in a Series 90-30 system is identified with a unique number called a “Rack Number.” Rack Numbers for Expansion and Remote baseplates are selected by setting a DIP switch located on each baseplate directly above the connector for Slot 1. Rack number 0 must always be present and is assigned, by default, to the CPU rack (the CPU baseplate does not have this DIP switch). Racks do not need to be contiguously numbered, although for consistency and clarity, it is recommended that rack numbers not be skipped (use 1, 2, 3 - not 1, 3, 5). Rack numbers must not be duplicated within a system. The following table shows the DIP switch positions for rack number selection.

Table 3-1. Rack Number Selection Switch Settings

DIP Switch	Rack Number						
	1	2	3	4	5*	6*	7*
1	open	closed	open	closed	open	closed	open
2	closed	open	open	closed	closed	open	open
3	closed	closed	closed	open	open	open	open

* Rack numbers 5, 6, and 7 only valid for CPUs 350 and higher.

The particular CPU module used determines how many expansion and remote baseplates are allowed:

- The 331, 340, and 341 CPUs support a total of 4 Expansion and/or Remote racks.
- The 350, 351, 352, 360, 363, and 364 CPUs support a total of 7 Expansion and/or Remote racks.

Each baseplate has a label above the DIP switch that shows the settings for each rack number. The following figure shows this DIP switch package with an example of rack #2 number selected.

Note

Use a ball-point pen to set the DIP switches. In general, it is best to avoid using a pencil to set DIP switches since graphite (a gritty, conductive material) from the pencil can enter and damage the switch.

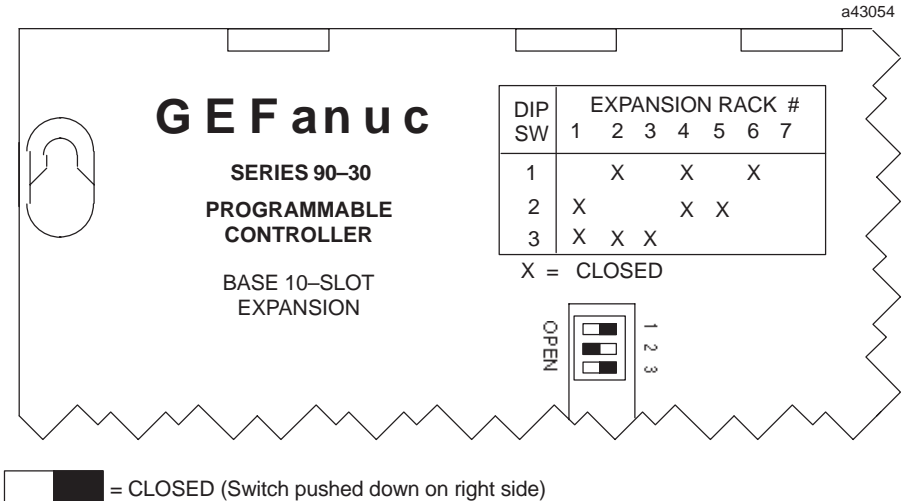

Figure 3-11. Rack Number Selection Switch (Shown with Rack 2 Selected)

Expansion Rack Connection Example

The following example shows a system that includes Expansion baseplates.

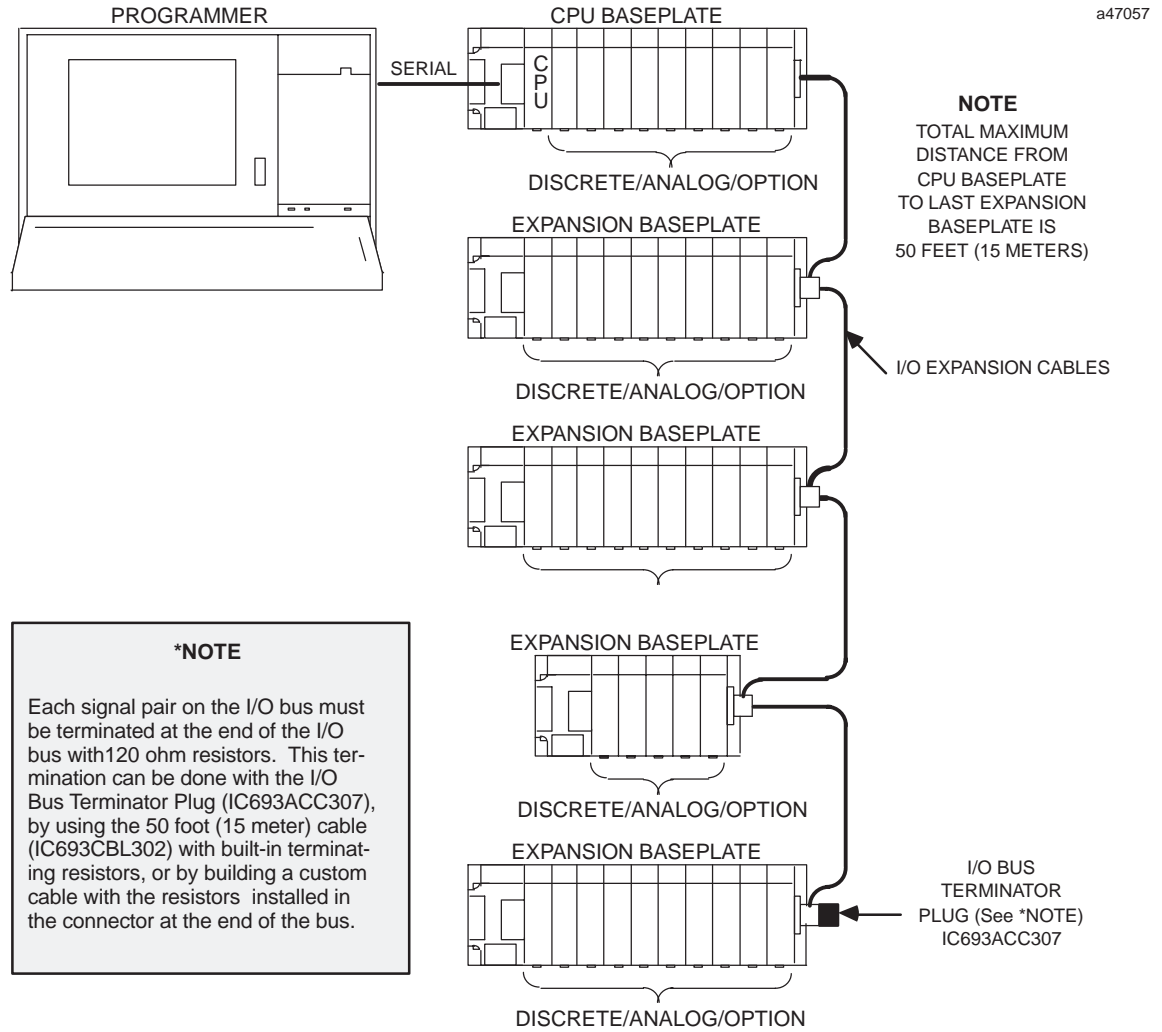

Figure 3-12. Example of Connecting Expansion Baseplates

Expansion and Remote Baseplates Connection Example

The following example shows cable connections in a system that includes both remote and expansion baseplates. A system can have a combination of remote and expansion baseplates as long as the distance and cable requirements are followed.

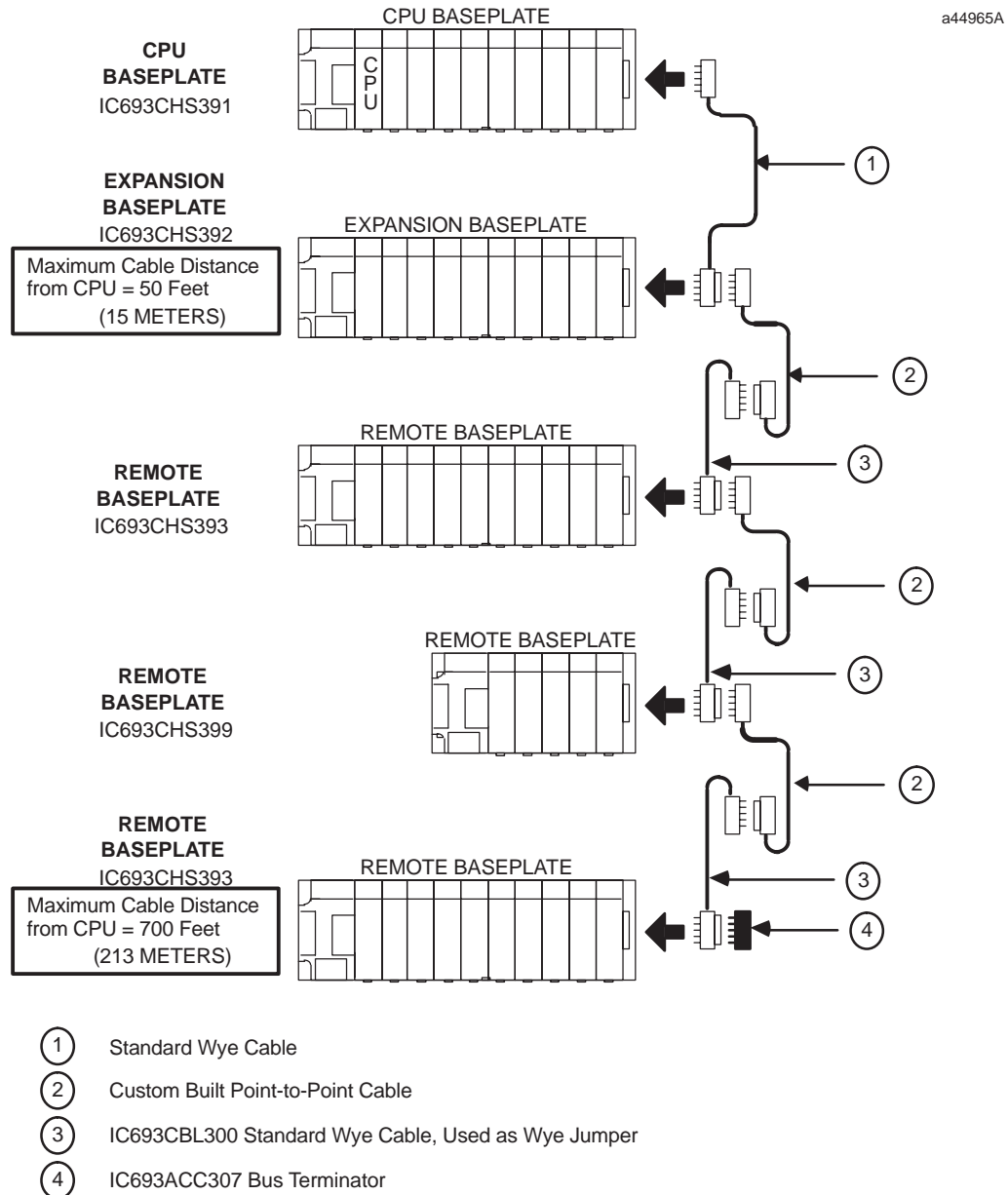

Figure 3-13. Example of Connecting Expansion and Remote Baseplates

Baseplate Mounting Dimensions

Series 90-30 PLC baseplates are designed to be panel mounted. Each baseplate has standard attachment flanges for mounting on an electrical panel. Baseplate dimensions and proper spacing requirements for installation purposes for both the 5 and 10-slot baseplates with embedded CPU (Models 311 and Model 313 are 5-slot baseplates; Model 323 is a 10-slot baseplate), and the 5 and 10-slot baseplates for Modular CPUs are shown in figures 3-1 through 3-4.

Note

All 5-slot baseplates have the same mounting dimensions and all 10-slot baseplates have the same mounting dimensions. *Baseplates must be mounted in the orientation as shown in the following figures for proper cooling.*

Embedded CPU (311, 313, and 323) Baseplate Dimensions

Baseplate dimensions and spacing requirements for installation for Models 311, 313, and 323 baseplates are shown below.

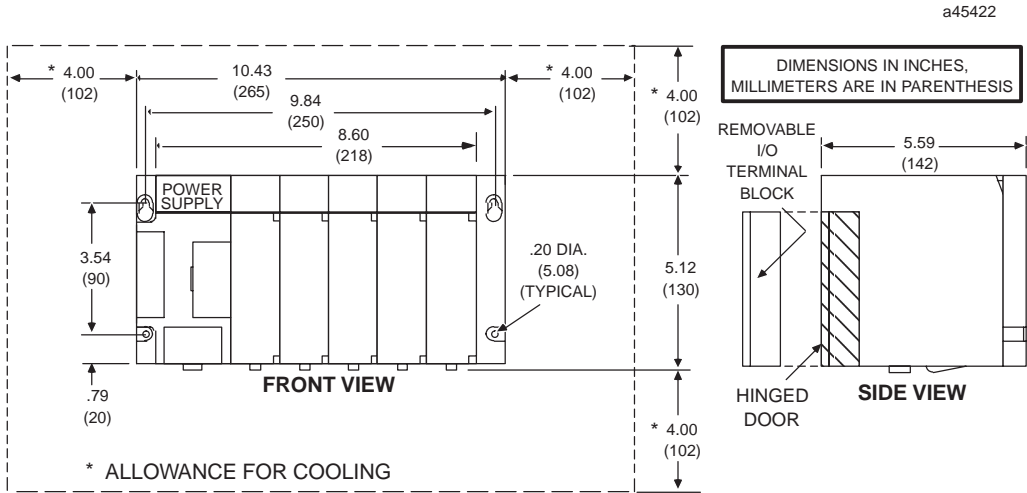

Figure 3-14. Model 311 and 313 5-Slot Baseplate Dimensions and Spacing Requirements

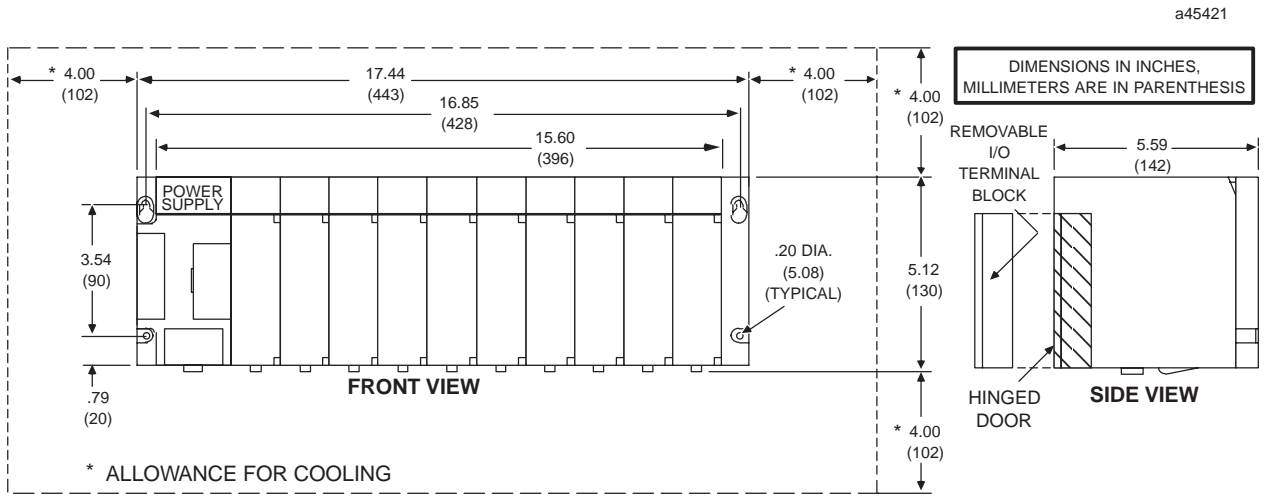

Figure 3-15. Model 323 10-Slot Baseplate Dimensions and Spacing Requirements

Modular CPU, Expansion, and Remote Baseplate Dimensions

Baseplate dimensions and spacing requirements for installation for Modular CPU baseplates are shown below.

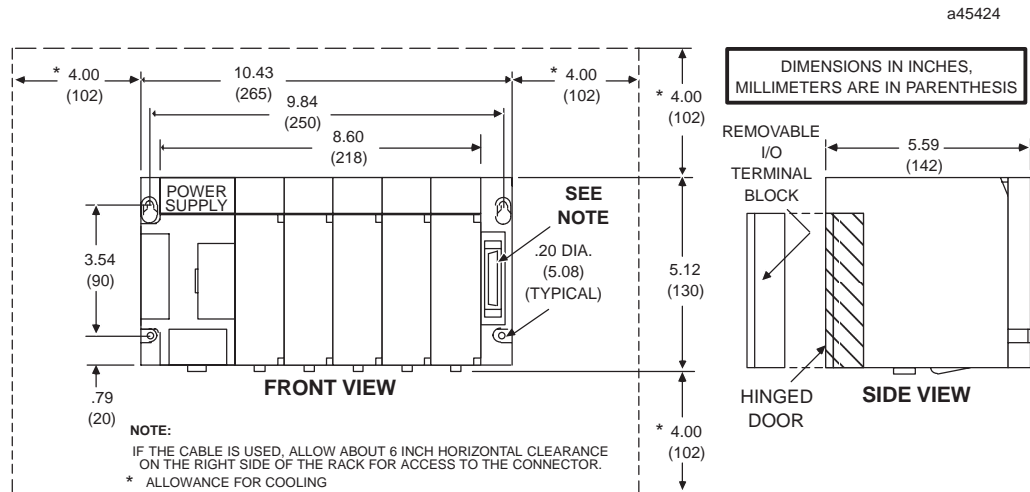

Figure 3-16. Modular CPU, Expansion, and Remote 5-Slot Baseplate Dimensions and Spacing Requirements

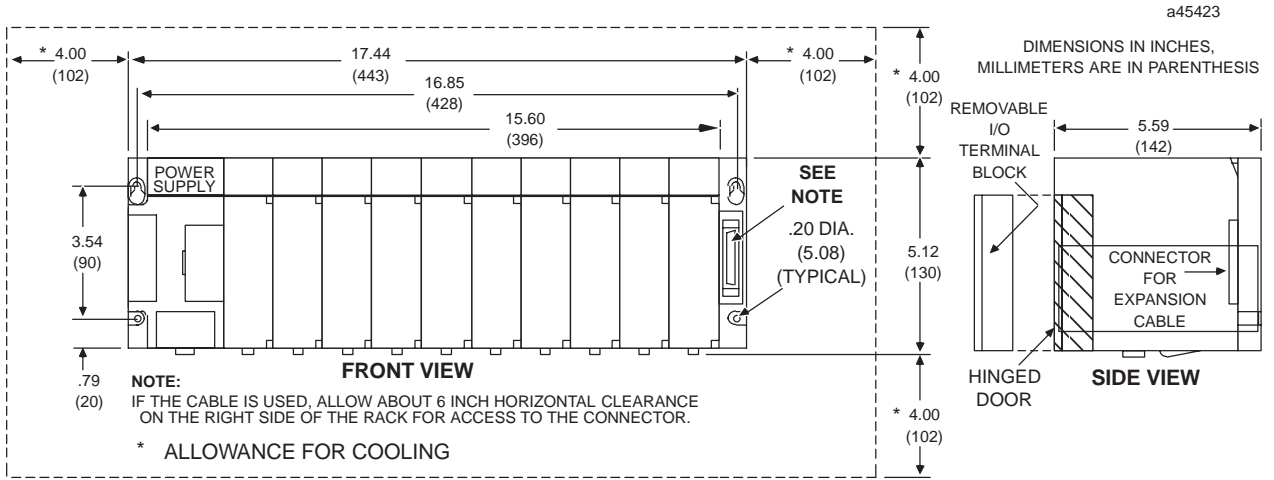

Figure 3-17. Modular CPU, Expansion, and Remote 10-Slot Baseplate Dimensions and Spacing Requirements

Load Ratings, Temperature, and Mounting Position

The power supply load rating depends on the mounting position of the baseplate and the ambient temperature.

The load rating with the baseplate mounted upright on a panel is:

- 100% at 60°C (140°F)

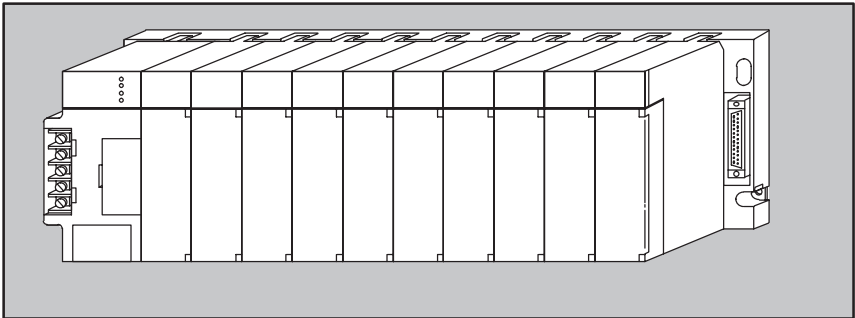

Power supply load ratings with the baseplate mounted horizontally are:

- temperature at 25°C (77°F) - full load
- temperature at 60°C (140°F) - 50% of full load

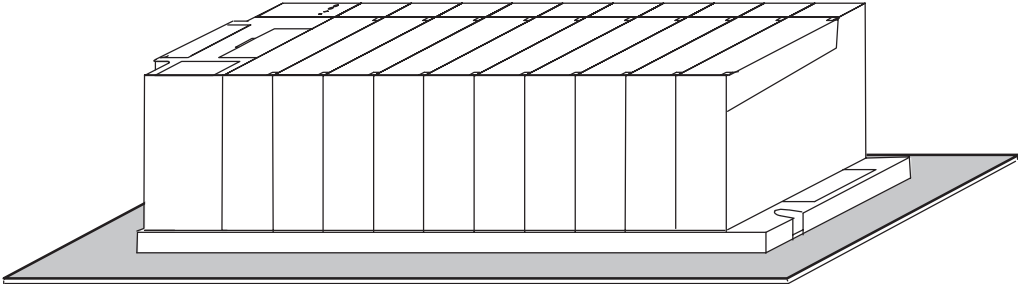

Baseplate Adapter Brackets for 19" Rack Mounting

Two optional Baseplate Adapter Brackets allow a 10-slot baseplate to be mounted in a 19 inch rack. Each baseplate installation requires only one of the adapter brackets.

Warning

Be sure to follow grounding instructions in Chapter 2 when using these adaptor brackets. Failure to properly ground the PLC can result in improper operation, damage to equipment, and injury to personnel.

- **IC693ACC308 Front Mount Adapter Bracket.** Used to mount a baseplate to the front face of a 19" rack. Install the adapter bracket by inserting the tabs at the top and bottom of the adapter bracket into the corresponding slots at the top and bottom of the plastic baseplate cover. **NOTE: Although the figure below shows the plastic baseplate cover removed, this is for illustration purposes only. It is not necessary to remove the cover to install the bracket.** With the bracket in place, insert and tighten the two screws (included with the bracket) through the back of the baseplate holes into the threaded holes in the bracket.
- **IC693ACC313 Recessed Mount Adapter Bracket.** Used to recess mount a baseplate inside a 19" rack. A baseplate mounts on the rear panel of this adapter bracket using four 8-32 (4 mm) screws, nuts, lockwashers and flat washers. The Adapter Bracket bolts through its four slotted holes to the face of the 19" rack using applicable hardware (lockwashers recommended).

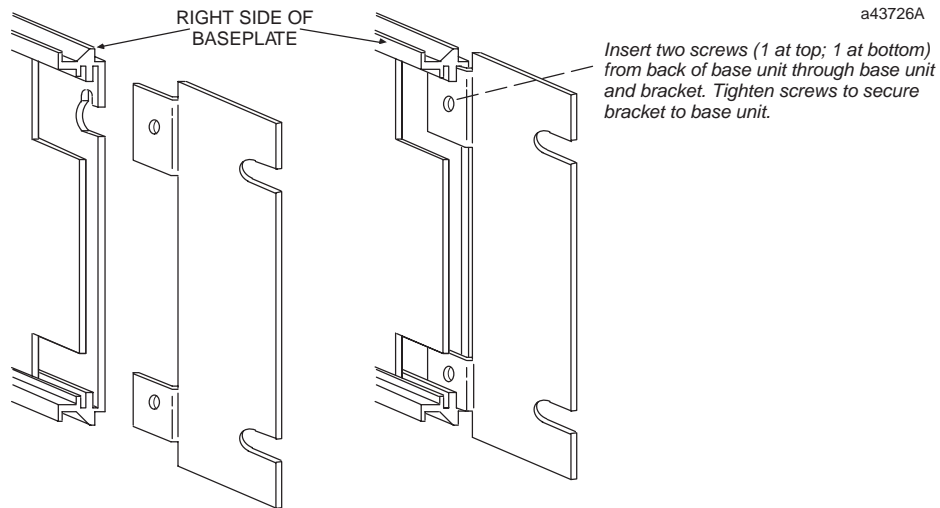

Note: Baseplate is shown with cover removed for illustration purposes. It is not necessary to remove the baseplate cover to install the bracket.

Figure 3-18. IC693ACC308 Front Mount Adapter Bracket Installation

Dimensions for rack mounting a 10-slot baseplate with the IC693ACC308 Front Mount Adapter Bracket are shown in the following figure.

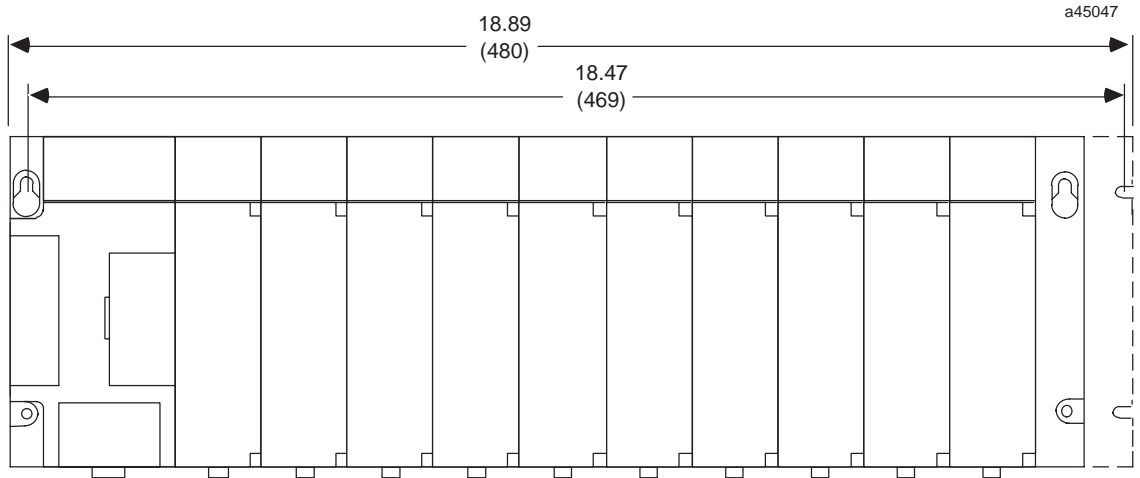

DIMENSIONS IN INCHES (MILLIMETERS IN PARENTHESES)

Figure 3-19. Dimensions for 19" Rack Mounting Using IC693ACC308 Adapter Bracket

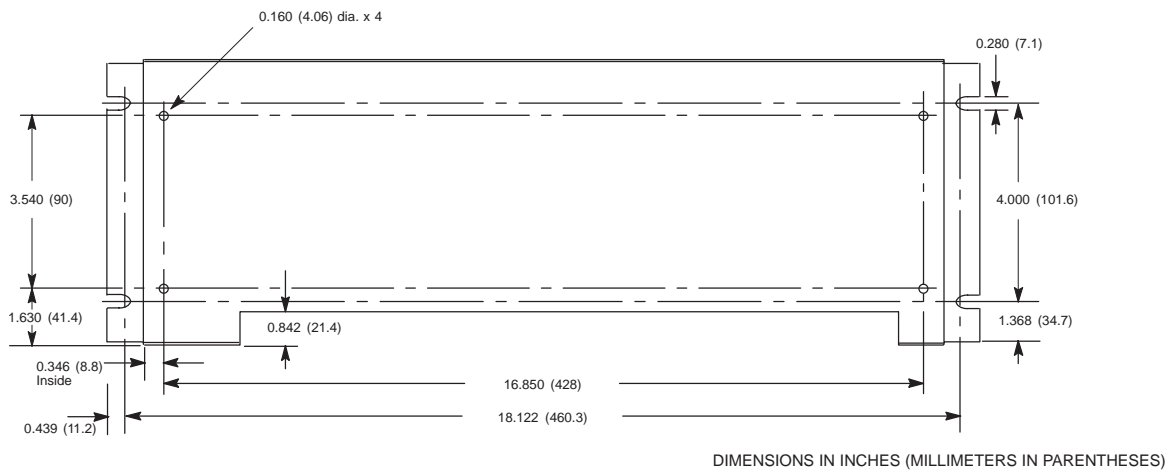

DIMENSIONS IN INCHES (MILLIMETERS IN PARENTHESES)

Figure 3-20. IC693ACC313 Recessed Mount Adapter Bracket

Baseplate Comparison Table

Table 3-2. Series 90-30 Baseplate Comparison

Series 90-30 Baseplates		
Catalog Number	Type	Size (Slots)
IC693CPU311	Embedded CPU	5
IC693CPU313	Embedded CPU	5
IC693CPU323	Embedded CPU	10
IC693CHS397	Modular CPU	5
IC693CHS391	Modular CPU	10
IC693CHS398	Expansion	5
IC693CHS392	Expansion	10
IC693CHS399	Remote	5
IC693CHS393	Remote	10

Chapter 4

Series 90–30 Power Supplies

efesotomasyon.com

Power Supply Categories

Series 90-30 power supplies are modular types that plug into the left slot of all 90-30 baseplates. They have been placed into two categories for the purpose of this chapter:

AC/DC Input Power Supplies

- IC693PWR321, Standard 120/240 VAC or 125 VDC input, 30 watts total output
- IC693PWR330, High Capacity 120/240 VAC or 125 VDC input, 30 watts total output

DC Input-Only Power Supplies

- IC693PWR322, 24/48 VDC input, 30 watts total output
- IC693PWR328 48 VDC input, 30 watts total output
- IC693PWR331, High Capacity 24 VDC input, 30 watts total output
- IC693PWR332, High Capacity 12 VDC input, 30 watts total output

Power Supply Feature Comparison

The following table lists the features of the Series 90-30 PLC Power Supplies.

Table 4-1. Power Supply Comparison Table

Catalog Number	Load Capacity	Nominal Input	Output Capacities (Voltage/Power †)		
			+5 VDC	+24 VDC Isolated	+24 VDC Relay
IC693PWR321	30 Watts	100 to 240 VAC or 125 VDC	+5 VDC 15 watts	+24 VDC Isolated 20 watts	+24 VDC Relay 15 watts
IC693PWR330	30 Watts	100 to 240 VAC or 125 VDC	+5 VDC 30 watts	+24 VDC Isolated 20 watts	+24 VDC Relay 15 watts
IC693PWR322	30 Watts	24 or 48 VDC	+5 VDC 15 watts	+24 VDC Isolated 20 watts	+24 VDC Relay 15 watts
IC693PWR328	30 Watts	48 VDC	+5 VDC 15 watts	+24 VDC Isolated 20 watts	+24 VDC Relay 15 watts
IC693PWR331	30 Watts	24 VDC	+5 VDC 30 watts	+24 VDC Isolated 20 watts	+24 VDC Relay 15 watts
IC693PWR332	30 Watts	12 VDC	+5 VDC 30 watts	+24 VDC Isolated 20 watts	+24 VDC Relay 15 watts

† Total of all outputs combined cannot exceed 30 watts.

AC/DC Input Power Supplies

IC693PWR321 Standard Power Supply, 120/240 VAC or 125 VDC Input

The IC693PWR321 is a 30 watt supply that can operate from an input voltage source in the range of 85 to 264 VAC or 100 to 300 VDC. This power supply provides three outputs:

- +5 VDC output,
- +24 VDC "Relay" power output which provides power to circuits on Series 90-30 Output Relay modules.
- "Isolated" +24 VDC, which is used internally by some modules, can also be used to provide external power for 24 VDC Input modules.

The load capacity for each output of this power supply is shown in the following table.

Table 4-2. IC693PWR321 Power Supply Capacities

Catalog Number	Load Capacity	Nominal Input	Output Capacities (Voltage/Power †)		
			+5 VDC 15 watts	+24 VDC Isolated 20 watts	+24 VDC Relay 15 watts
IC693PWR321	30 Watts	100 to 240 VAC or 125 VDC			

† Total of all outputs combined cannot exceed 30 watts.

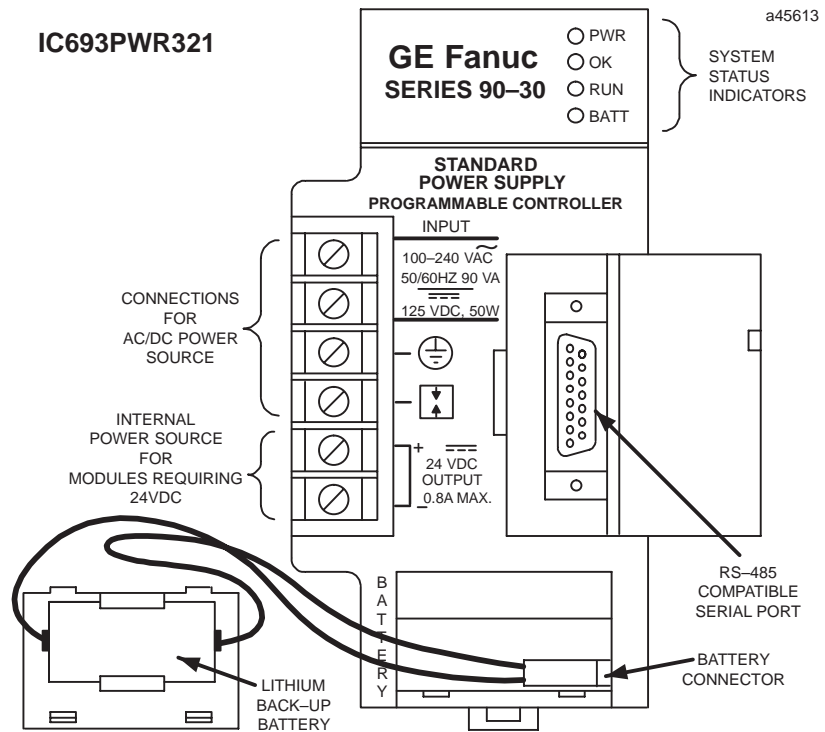

Figure 4-1. Standard AC/DC Input Power Supply - IC693PWR321

Power supplies must be installed in the leftmost slot in all baseplates.

Note

Previous versions of this power supply had five terminals on the terminal block. The new version (shown above), which has six terminals, is functionally the same as the previous version. The change was made to conform to European EC requirements.

Table 4-3. Specifications for IC693PWR321 Standard AC/DC Input Power Supply

Nominal Rated Voltage	120/240 VAC or 125 VDC
Input Voltage Range	
AC	85 to 264 VAC
DC	100 to 300 VDC
Input Power (Maximum with Full Load)	90 VA with VAC Input 50 W with VDC Input
Inrush Current	4A peak, 250 milliseconds maximum
Output Power	5 VDC and 24 VDC Relay: 15 watts maximum 24 VDC Relay: 15 watts maximum 24 VDC Isolated: 20 watts maximum <i>NOTE: 30 watts maximum total (all three outputs)</i>
Output Voltage	5 VDC: 5.0 VDC to 5.2 VDC (5.1 VDC nominal) Relay 24 VDC: 24 to 28 VDC Isolated 24 VDC: 21.5 VDC to 28 VDC
Protective Limits	
Overvoltage:	5 VDC output: 6.4 to 7 V
Overcurrent:	5 VDC output: 4 A maximum
Holdup Time:	20 milliseconds minimum

IC693PWR330 High Capacity Power Supply, 120/240 VAC/125 VDC Input

The IC693PWR330 High Capacity Power Supply is rated for 30 watts output. *For applications requiring greater +5V current capacity than is available with the standard supply (IC693PWR321), this supply allows all 30 watts to be consumed from the +5V supply.* It can operate from an input voltage source in the range of 85 to 264 VAC or 100 to 300 VDC. This power supply provides the following outputs:

- +5 VDC output.
- +24 VDC "Relay" power output which provides power to circuits on Series 90-30 Output Relay modules.
- "Isolated" +24 VDC, which is used internally by some modules, can also be used to provide external power for 24 VDC Input modules.

The load capacity for each output of this power supply is shown in the following table.

Table 4-4. IC693PWR330 Power Supply Capacities

Catalog Number	Load Capacity	Nominal Input	Output Capacities (Voltage/Power †)		
			+5 VDC 30 watts	+24 VDC Isolated 20 watts	+24 VDC Relay 15 watts
IC693PWR330	30 Watts	100 to 240 VAC or 125 VDC			

† Total of all outputs combined cannot exceed 30 watts.

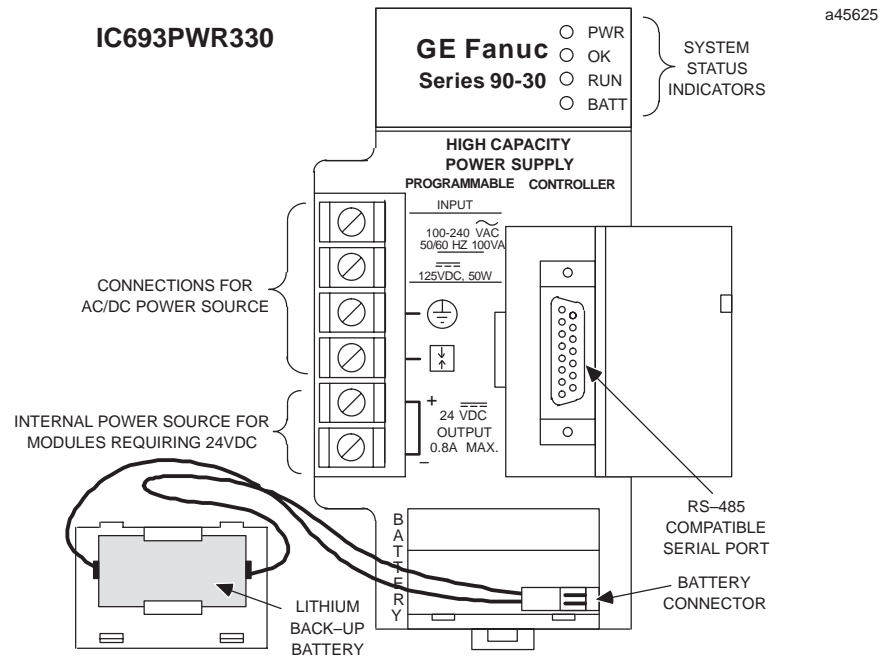

Figure 4-2. High Capacity AC/DC Input Power Supply - IC693PWR330

Table 4-5. Specifications for IC693PWR330 High Capacity AC/DC Input Power Supply

Nominal Rated Voltage	120/240 VAC or 125 VDC
Input Voltage Range	
AC	85 to 264 VAC
DC	100 to 300 VDC
Input Power (Maximum with Full Load)	100 VA with VAC Input 50 W with VDC Input
Inrush Current	4A peak, 250 ms maximum
Output Power	5 VDC: 30 watts maximum 24 VDC Relay: 15 watts maximum 24 VDC Isolated: 20 watts maximum <i>NOTE: 30 watts maximum total (all three outputs)</i>
Output Voltage	5 VDC: 5.0 VDC to 5.2 VDC (5.1 VDC nominal) 24 VDC Relay: 24 to 28 VDC 24 VDC Isolated: 21.5 VDC to 28 VDC
Protective Limits	
Overvoltage:	5 VDC output: 6.4 to 7 V
Overcurrent:	5 VDC output: 7 A maximum
Ride-Through Time:	20 ms minimum

Field Wiring Connections for the AC/DC Input Power Supplies

The two AC/DC input power supplies have six terminals for user connections. These connections are described below.

AC Power Source Connections

The Hot, Neutral, and Ground wires from the 120 VAC power source or L1, L2, and Ground wires from the 240 VAC power source connect to the system through the top three terminals of the terminal strip on the front of the power supply.

DC Power Source Connections

Connect the + and – wires from the 125 VDC (nominal) power source to the top two terminals on the terminal connector. These connections are not polarity-sensitive on an AC/DC input power supply; however, for systems with more than one baseplate, the input wiring polarity must be consistent (see the section “DC Power Source Connections” in Chapter 2 for details on this). NOTE: The DC Input-only type supplies, which are discussed later in this chapter, are polarity sensitive.

Input Overvoltage Protection Devices

This information applies to all Series 90-30 power supplies that have six-terminal boards. The overvoltage protection devices for this power supply are connected internally to pin 4 on the user terminal strip. This pin is normally connected to frame ground (pin 3) with the supplied jumper strap which is installed at the factory. If overvoltage protection is not required *or* is supplied upstream, this feature can be disabled by removing the jumper strap from pins 3 and 4.

If you want to Hi-pot test this supply, overvoltage protection *must be disabled* during the test by removing the terminal strip jumper strap. Re-enable overvoltage protection after testing by reinstalling the strap.

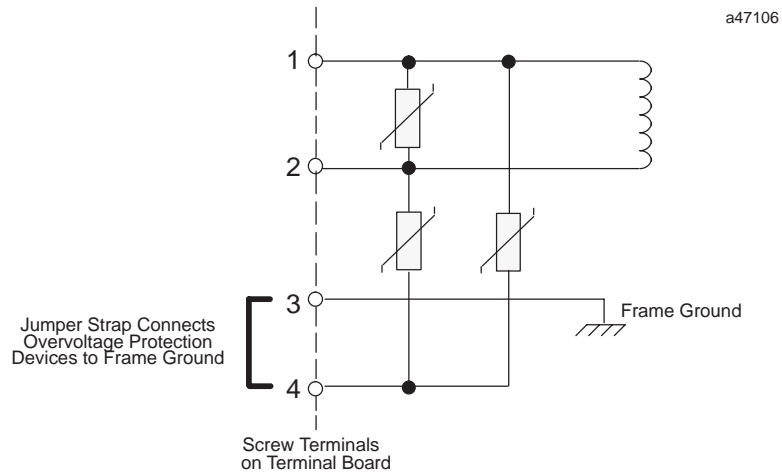

Figure 4-3. Overvoltage Protection Devices and Jumper Strap

Isolated 24 VDC Supply Output Connections

The bottom two terminals of the power supply terminal strip provide connections to the Isolated +24 volt DC output which can be used to provide power for external circuits (within power limitations of the supply).

Caution

If the Isolated 24 VDC supply is overloaded or shorted, the Programmable Logic Controller will stop operation.

DC Input Only Power Supplies

IC693PWR322 Standard Power Supply, 24/48 VDC Input

The IC693PWR322 is a 30 watt output power supply designed for 24 VDC or 48 VDC nominal inputs. It will accept an input voltage range from 18 VDC to 56 VDC. Although it is capable of maintaining all outputs within specifications with input voltages as low as 18 VDC, it will not start with initial input voltages of less than 21 VDC. This power supply provides the following outputs:

- +5 VDC output.
- +24 VDC "Relay" power output which provides power to circuits on Series 90-30 Output Relay modules.
- "Isolated" +24 VDC, which is used internally by some modules, can also be used to provide external power for 24 VDC Input modules.

The load capacity for each output of this power supply is shown in the following table.

Table 4-6. IC693PWR322 Power Supply Capacities

Catalog Number	Load Capacity	Input	Output Capacities (Voltage/Power †)		
IC693PWR322	30 Watts	24 or 48 VDC	+5 VDC 15 watts	+24 VDC Isolated 20 watts	+24 VDC Relay 15 watts

† Total of all outputs combined cannot exceed 30 watts.

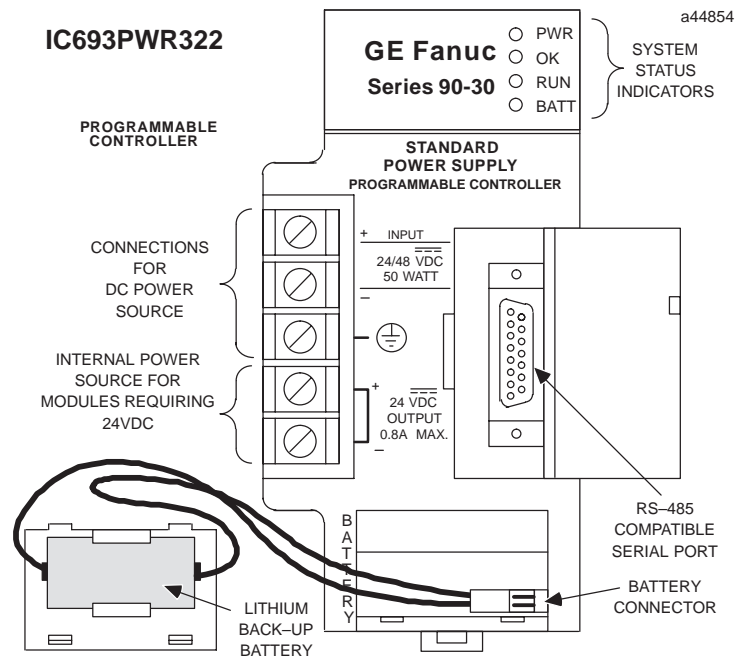

Figure 4-4. Series 90-30 24/48 VDC Input Power Supply - IC693PWR322

Table 4-7. Specifications for IC693PWR322 Power Supply

Nominal Rated Voltage	24 or 48 VDC
Input Voltage Range	
Start	21 to 56 VDC
Run	18 to 56 VDC
Input Power	50 watts maximum at full load
Inrush Current	4A peak, 100 ms maximum
Output Power	5 VDC: 15 watts maximum 24 VDC Relay: 15 watts maximum 24 VDC Isolated: 20 watts maximum <i>NOTE: 30 watts maximum total (all three outputs)</i>
Output Voltage	5 VDC: 5.0 VDC to 5.2 VDC (5.1 VDC nominal) 24 VDC Relay: 24 to 28 VDC 24 VDC Isolated: 21.5 VDC to 28 VDC
Protective Limits	
Overvoltage;	5 VDC output: 6.4 to 7 V
Overcurrent;	5 VDC output: 4 A maximum
Holdup Time:	14 ms minimum
Standards	Refer to data sheet, GFK-0867B, or later version for product standards, and general specifications.

Calculating Input Power Requirements for IC693PWR322

The following graph is a typical 24/48 VDC power supply efficiency curve. A basic procedure for determining efficiency of the 24/48 VDC power supply follows the figure.

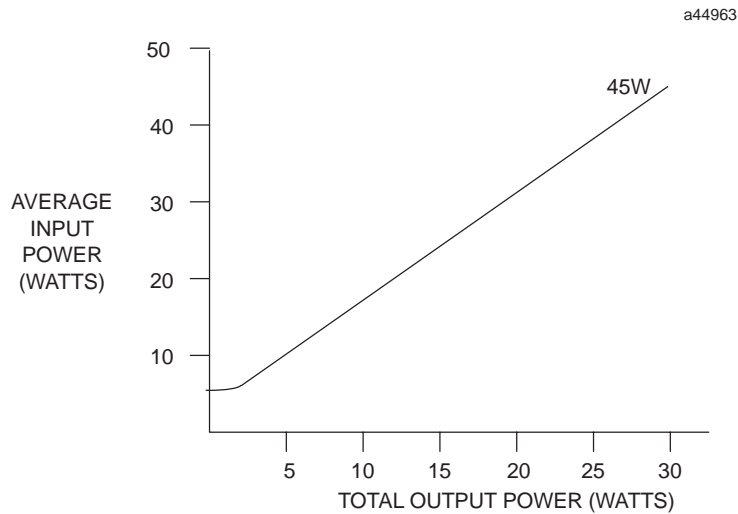

Figure 4-5. Typical Efficiency Curve for 24/48 VDC Power Supply

Note

Start-up surge at full load is 4 amps for 250 milliseconds (maximum).

Input Power/Current Calculation

- Determine total output load from typical specifications listed for individual modules in Chapters 2 and 3.
- Use the graph to determine average input power.
- Divide the input power by the operating source voltage to determine the input current requirements.
- Use the lowest input voltage to determine the maximum input current.
- Allow for start-up surge current requirements.
- Allow margins (10% to 20%) for variations.

IC693PWR328 Standard Power Supply, 48 VDC Input

The IC693PWR328 is a 30 watt output power supply designed for 48 VDC nominal input. It will accept an input voltage range from 38 VDC to 56 VDC. This power supply provides the following outputs:

- +5 VDC output.
- +24 VDC "Relay" power output which provides power to circuits on Series 90-30 Output Relay modules.
- "Isolated" +24 VDC, which is used internally by some modules, can also be used to provide external power for 24 VDC Input modules.

The load capacity for each output of this power supply is shown in the following table.

Table 4-8. IC693PWR328 Power Supply Capacities

Catalog Number	Load Capacity	Input	Output Capacities (Voltage/Power †)		
IC693PWR328	30 Watts	48 VDC	+5 VDC 15 watts	+24 VDC Isolated 20 watts	+24 VDC Relay 15 watts

† Total of all outputs combined cannot exceed 30 watts.

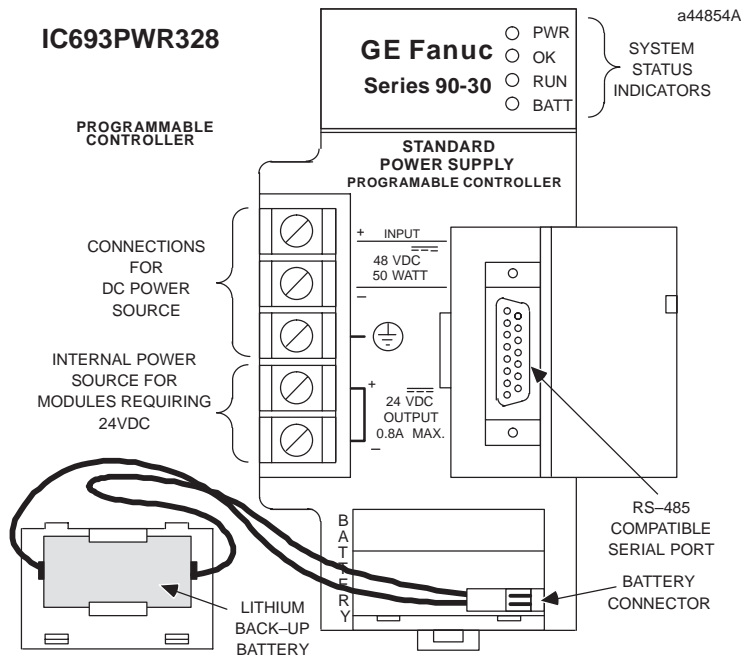

Figure 4-6. Series 90-30 48 VDC Input Power Supply - IC693PWR328

Table 4-9. Specifications for IC693PWR328 Power Supply

Nominal Rated Voltage	48 VDC
Input Voltage Range	38 to 56 VDC
Input Power	50 watts maximum at full load
Inrush Current	4A peak, 100 ms maximum
Output Power	5 VDC: 15 watts maximum 24 VDC Relay: 15 watts maximum 24 VDC Isolated: 20 watts maximum <i>NOTE: 30 watts maximum total (all three outputs)</i>
Output Voltage	5 VDC: 5.0 VDC to 5.2 VDC (5.1 VDC nominal) 24 VDC Relay: 24 to 28 VDC 24 VDC Isolated: 21.5 VDC to 28 VDC
Protective Limits	
Overvoltage;	5 VDC output: 6.4 to 7 V
Overcurrent;	5 VDC output: 4 A maximum
Ride-Through Time:	14 ms minimum
Standards	Refer to data sheet, GFK-0867B, or later version for product standards, and general specifications.

Calculating Input Power Requirements for IC693PWR328

The following graph is a typical 48 VDC power supply efficiency curve. A basic procedure for determining efficiency of the 48 VDC power supply follows the figure.

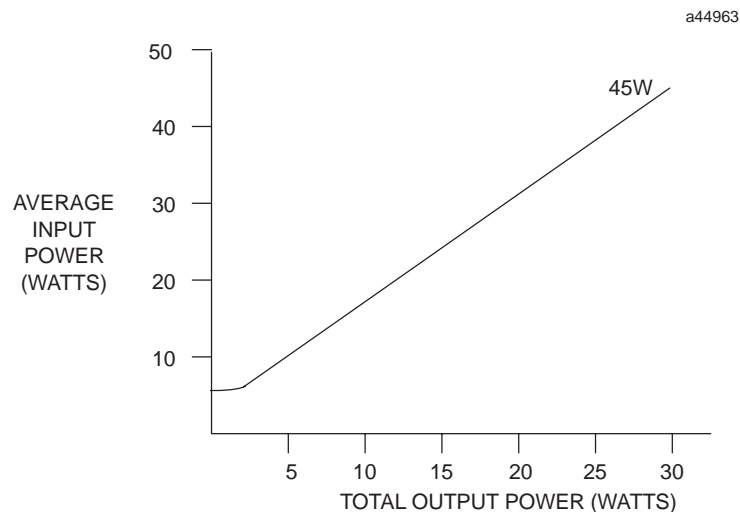

Figure 4-7. Typical Efficiency Curve for IC693PWR328 Power Supply

Note

Start-up surge at full load is 4 amps for 250 milliseconds (maximum).

Input Power/Current Calculation for IC693PWR328 Power Supply

- Determine total output load from typical specifications listed for individual modules in Chapter 12.
- Use the graph to determine average input power.
- Divide the input power by the operating source voltage to determine the input current requirements.
- Use the lowest input voltage to determine the maximum input current.
- Allow for start-up surge current requirements.
- Allow margins (10% to 20%) for variations.

IC693PWR331 High Capacity Power Supply, 24 VDC Input

The Series 90-30 DC input High Capacity power supply (IC693PWR331) is a 30 watt wide range supply designed for 24 VDC nominal inputs. *For applications requiring greater +5V current capacity than is available with the standard supply, this supply allows all 30 watts to be consumed from the +5 V output.* It will accept an input voltage range from 12 VDC to 30 VDC. Although it is capable of maintaining all outputs within specifications with input voltages as low as 12 VDC, it will not start with initial input voltages of less than 18 VDC. This power supply provides the following outputs:

- +5 VDC output.
- +24 VDC "Relay" power output which provides power to circuits on Series 90-30 Output Relay modules.
- "Isolated" +24 VDC, which is used internally by some modules, can also be used to provide external power for 24 VDC Input modules.

The load capacity for each output of this power supply is shown in the following table.

Table 4-10. IC693PWR331 Power Supply Capacities

Catalog Number	Load Capacity	Input	Output Capacities (Voltage/Power †)		
IC693PWR331	30 Watts	12 to 30 VDC	+5 VDC 30 watts	+24 VDC Isolated 20 watts	+24 VDC Relay 15 watts

† Total of all outputs combined cannot exceed 30 watts.

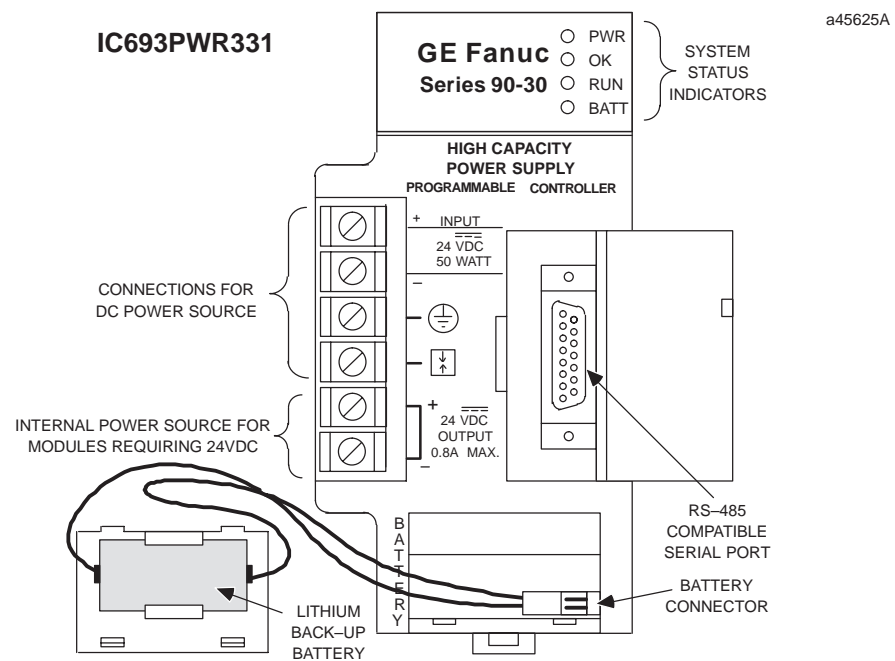

Figure 4-8. Series 90-30 24 VDC Input High Capacity Power Supply - IC693PWR331

Table 4-11. Specifications for IC693PWR331 Power Supply

Nominal Rated Voltage	24 VDC
Input Voltage Range	18 to 30 VDC
Start	18 to 30 VDC
Run	12 to 30 VDC
Input Power	50 watts maximum at full load
Inrush Current	4 Amps peak, 100 milliseconds maximum
Output Power	5 VDC: 30 watts maximum ‡ 24 VDC Relay: 15 watts maximum 24 VDC Isolated: 20 watts maximum <i>NOTE: 30 watts maximum total (all three outputs)</i>
Output Voltage	5 VDC: 5.0 VDC to 5.2 VDC (5.1 VDC nominal) 24 VDC Relay: 19.2 to 28.8 VDC 24 VDC Isolated: 19.2 VDC to 28.8 VDC
Protective Limits	
Overvoltage:	5 VDC output: 6.4 to 7 V
Overcurrent;	5 VDC output: 7 A maximum
Ride-Through Time:	10 ms minimum
Standards	Refer to data sheet, GFK-0867B, or later version for product standards, and general specifications.

‡ Derate per figure below at ambient temperatures above 50°C (122°F).

Current Derating for Higher Temperatures

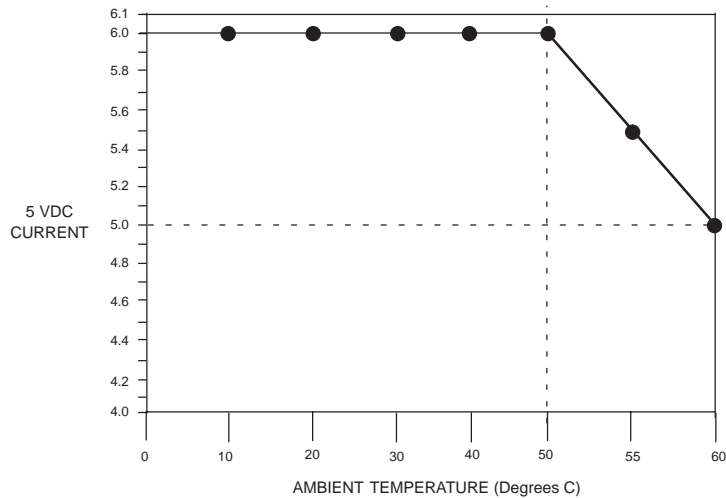

Figure 4-9. 5 VDC Current Output Derating for Temperatures above 50°C (122°F)

Calculating Input Power Requirements for IC693PWR331

Use the following procedure to determine input power requirements for the 24 VDC High Capacity Power Supply:

- Determine total output power load from typical specifications listed for individual modules at the end of this chapter.
- Multiply the output power by 1.5 to determine the input power value.
- Divide the input power value by the operating source voltage to determine the input current requirements
- Use the lowest input voltage to determine the maximum input current
- Allow for start-up surge current requirements
- Allow margins (10% to 20%) for variations

IC693PWR332 High Capacity Power Supply, 12 VDC Input

The Series 90-30 DC input High Capacity power supply (IC693PWR332) is a 30 watt wide range supply designed for 12 VDC nominal input power. It will accept an input voltage range from 9.6 VDC to 15 VDC. This power supply provides the following outputs:

- +5 VDC output.
- +24 VDC "Relay" power output which provides power to circuits on Series 90-30 Output Relay modules.
- "Isolated" +24 VDC, which is used internally by some modules, can also be used to provide external power for 24 VDC Input modules.

The load capacities for each output of the power supply are shown in the following table.

Table 4-12. High Capacity 12 VDC Input Power Supply Capacities

Catalog Number	Load Capacity	Input	Output Capacities (Voltage/Power †)		
			+5 VDC	+24 VDC Isolated	+24 VDC Relay
IC693PWR331	30 Watts	9.6 to 15 VDC	30 watts	20 watts	15 watts

† Total of all outputs combined cannot exceed 30 watts.

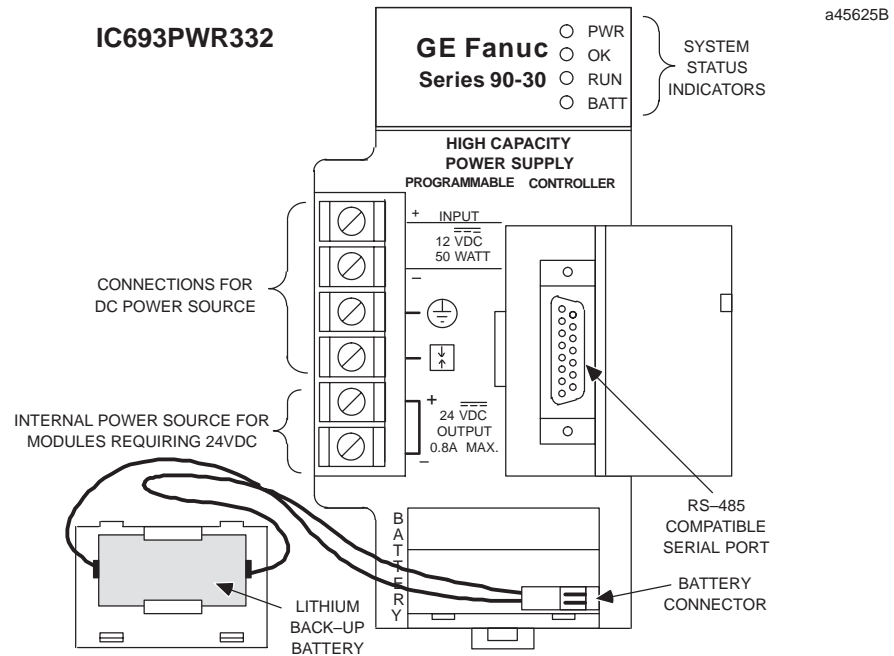

Figure 4-10. Series 90-30 12 VDC Input High Capacity Power Supply - IC693PWR332

Table 4-13. Specifications for IC693PWR332

Nominal Rated Voltage	12 VDC
Input Voltage Range	9.6 to 15 VDC
Input Power	50 watts maximum at full load
Inrush Current	4 Amps peak, 100 milliseconds maximum
Output Power	5 VDC: 30 watts maximum ‡ 24 VDC Relay: 15 watts maximum: 24 VDC Isolated: 20 watts maximum: 30 watts maximum total (all three outputs)
Output Voltage	5 VDC: 5.0 VDC to 5.2 VDC (5.1 VDC nominal) Relay 24 VDC: 19.2 to 28.8 VDC Isolated 24 VDC: 19.2 VDC to 28.8 VDC
Protective Limits	
Overvoltage:	5 VDC output: 6.4 to 7 V
Overcurrent;	5 VDC output: 7 A maximum
Ride-Through Time:	10 ms minimum
Standards	Refer to data sheet, GFK-0867B, or later version for product standards, and general specifications.

‡ Derate per figure below at ambient temperatures above 50°C (122°F).

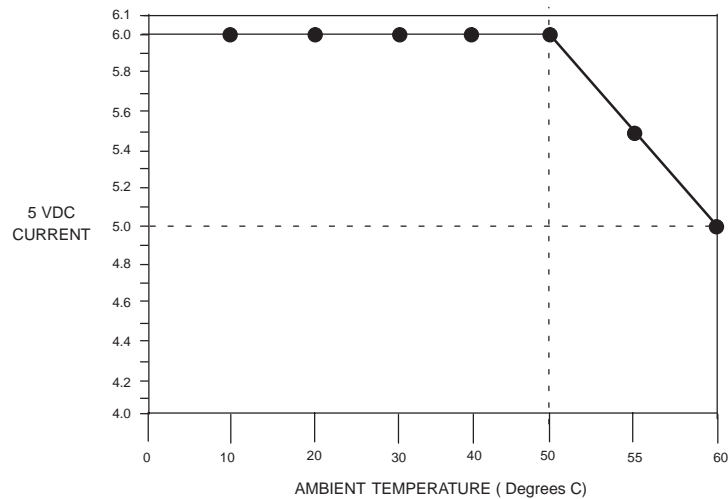

Figure 4-11. 5 VDC Current Output Derating for Temperatures above 50°C (122°F)

Calculating Input Power Requirements for IC693PWR332

Use the following procedure to determine input power requirements for the 12 VDC High Capacity Power Supply:

- Determine total output power load from typical specifications listed for individual modules at the end of this chapter.
- Multiply the output power by 1.5 to determine the input power value.
- Divide the input power value by the operating source voltage to determine the input current requirements
- Use the lowest input voltage to determine the maximum input current
- Allow for start-up surge current requirements
- Allow margins (10% to 20%) for variations

Field Wiring Connections to the DC Input-Only Power Supplies

DC Power Source Connections

The + and – wires from the DC power source connect to the top two terminals on the terminal strip. The + wire should be connected to the top terminal screw, and the – wire to the second screw (counting from the top down). The ground connection connects to the third screw. This connection scheme is clearly marked on the front of these power supplies.

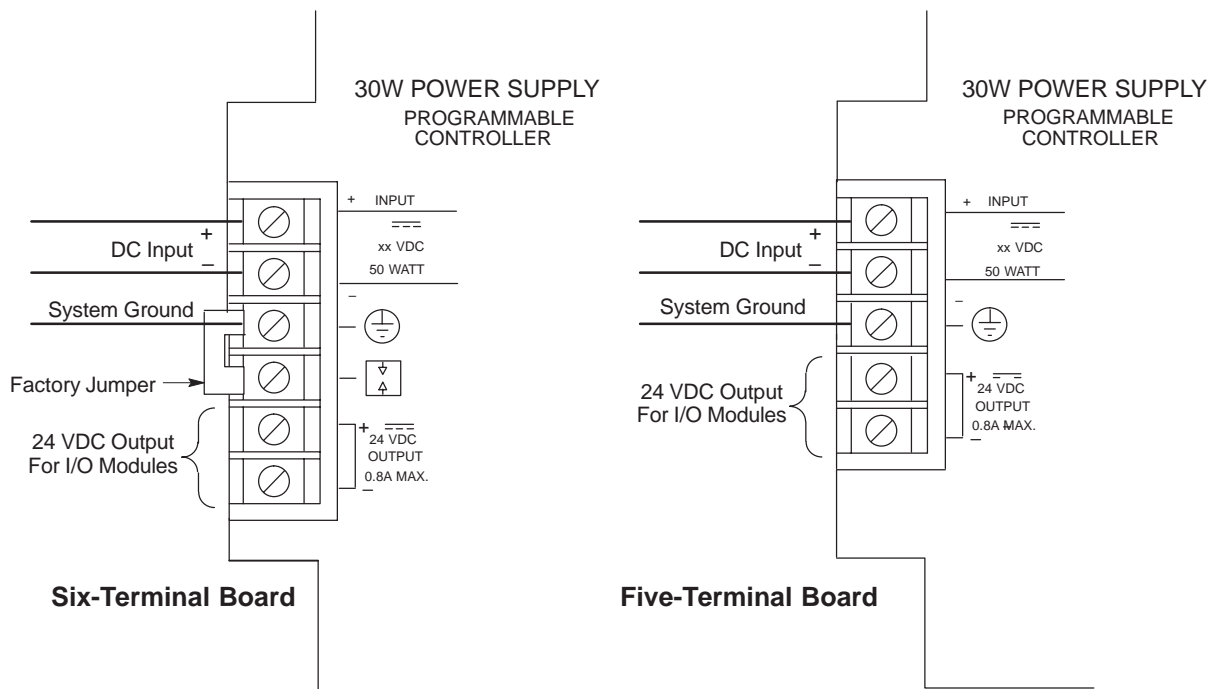

Isolated 24 VDC Supply Output Connections

The bottom two terminals of the power supply terminal strip provide connections to the Isolated +24 volt DC output which can be used to provide power for external circuits (within power limitations of the supply).

Caution

If the Isolated 24 VDC supply is overloaded or shorted, the Programmable Logic Controller will stop operation.

Common Series 90-30 Power Supply Features

Status Indicator Lights on all Power Supplies

Four LEDs are located on the upper right front of the power supply faceplate. The purpose of these LEDs is as follows:

PWR

The top green LED, labeled **PWR**, provides an indication of the operating state of the power supply. The LED is *ON* when the power supply has a correct source of power and is operating properly, and *OFF* when a power supply fault occurs or power is not applied.

OK

The second green LED, labeled **OK**, is steady *ON* if the PLC is operating properly, and *OFF* if a problem is detected by the PLC.

RUN

The third green LED, labeled **RUN**, is steady *ON* when the PLC is in the RUN mode.

BATT

The bottom red LED, labeled **BATT**, will be *ON* if the memory backup battery voltage is too low to maintain the memory under a loss of power condition; otherwise it remains *OFF*. If this LED is ON, the Lithium battery must be replaced before removing power from the rack, or PLC memory may be lost.

Input Overvoltage Protection Devices

This information applies to all Series 90-30 power supplies that have six-terminal boards. The overvoltage protection devices for this power supply are connected internally to pin 4 on the user terminal strip. This pin is normally connected to frame ground (pin 3) with the supplied jumper strap which is installed at the factory. If overvoltage protection is not required *or* is supplied upstream, this feature can be disabled by removing the jumper strap from pins 3 and 4.

If you want to Hi-pot test this supply, overvoltage protection *must be disabled* during the test by removing the terminal strip jumper strap. Re-enable overvoltage protection after testing by reinstalling the strap.

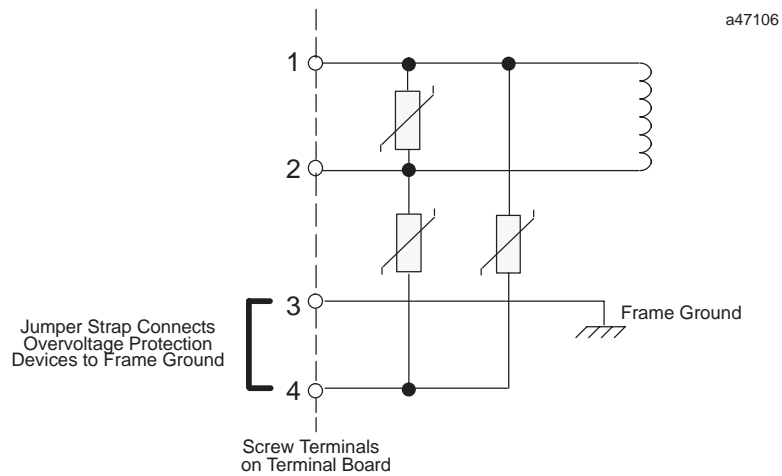

Figure 4-12. Overvoltage Protection Devices and Jumper Strap

Output Voltage Connections to Backplane (All Supplies)

The following figure illustrates how these three output voltages are connected internally to the backplane on the baseplate. The voltage and power required by modules installed on the baseplate is supplied through the baseplate connectors.

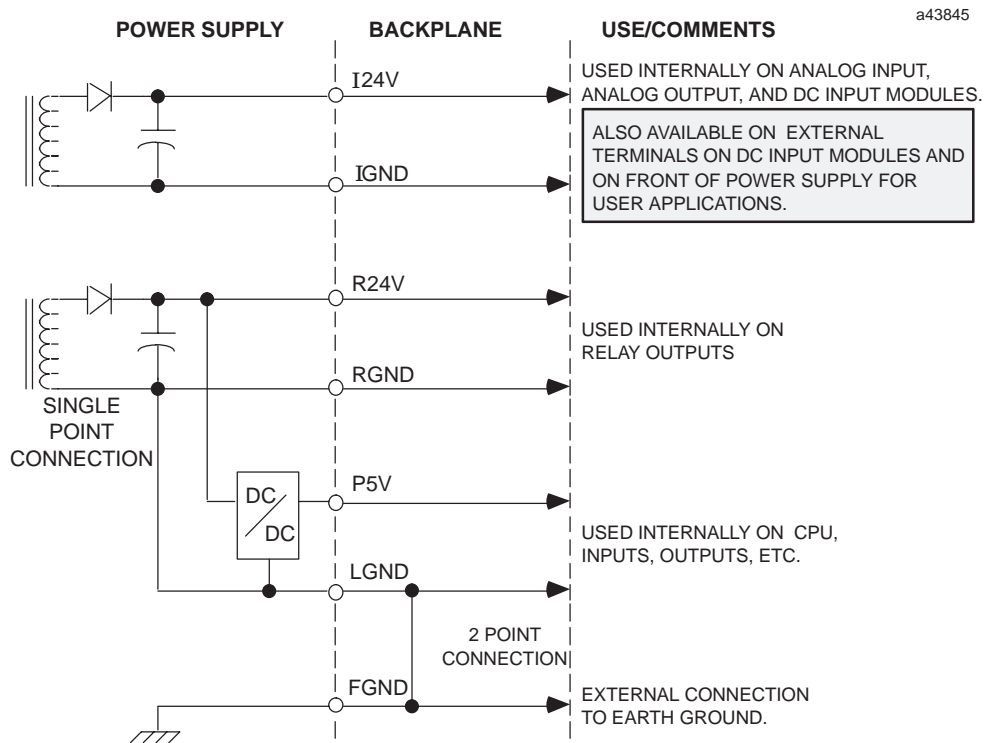

Figure 4-13. Internal Power Supply Connections

Overcurrent Protection (all Supplies)

The 5V logic output is electronically limited to 3.5 amps (7 amps for high capacity supplies). An overload (including short circuits) is sensed internally and causes the supply to shut down. The supply will continually try to restart until the overload is removed. An internal fuse in the input line is provided as a backup. The supply will usually shut down before the fuse blows. The fuse also protects against internal supply faults.

Timing Diagram

The timing diagram below shows the relationship of the DC input to the DC outputs and to the Power Supply OK signal (PSOK) generated by the power supply. When power is first applied, the PSOK signal goes false. This line remains false for a minimum of 20 msec after the +5V bus is within specifications, then it becomes true.

If input power is interrupted, the +5V bus will remain within specifications and PSOK will remain true a minimum of 10 milliseconds. PSOK then goes false. The +5V bus will remain within specifications for an additional 4 milliseconds minimum to allow an orderly shutdown of the system.

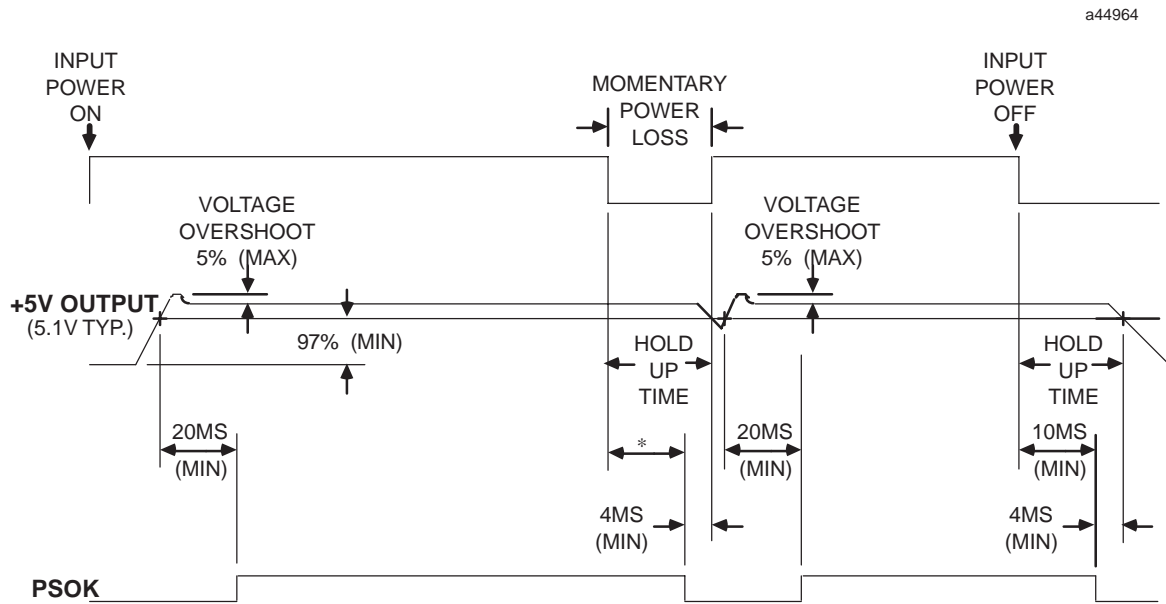

a44964

* Ride-Through Time: 20 ms, minimum for IC693PWR321/330
 14 ms, minimum for IC693PWR322/328
 10 ms, minimum for IC693PWR331/332

Figure 4-14. Timing Diagram for all Series 90-30 Power Supplies

CPU Serial Port Connector on Power Supply (All Supplies)

A 15-pin D-type female connector, accessed by opening the hinged door on the right front of the power supply, provides the connection to a CPU serial port which is used to connect to:

- A programmer (usually a personal computer) running GE Fanuc PLC programming software.
- The GE Fanuc Hand-Held Programmer.
- Other serial devices.

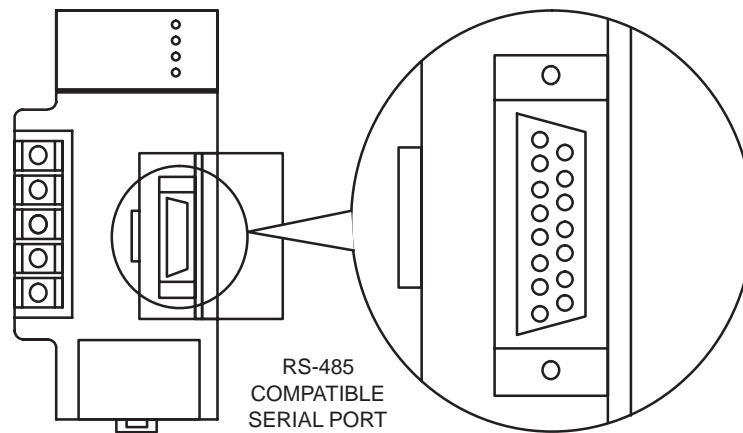

Figure 4-15. Serial Port Connector

- The serial port connector is only functional in a power supply that is installed in a baseplate that also contains the CPU. *The serial port is not functional on a power supply that is installed in an expansion or remote baseplate.*
- Any device connected to the serial port that uses +5 VDC power from the Series 90-30 power supply **must be included** in the calculation for maximum power consumption (see the heading “Power Supply Loading Calculations” in Chapter 12).

CPU Serial Port Information

The serial port connector on the power supply accesses the CPU serial port, which is a feature of all Series 90-30 CPUs. See Chapter 5, “CPUs” for information on this serial port.

Backup Battery for RAM Memory (All Supplies)

The long-life Lithium battery (IC693ACC301) used to maintain the contents of the CMOS RAM memory in the CPU is accessed by removing the cover plate located at the bottom of the power supply faceplate. This battery is mounted on a plastic clip attached to the inside of this cover.

The battery is wired to a small Berg female connector that connects to either of the two Berg male connectors mounted on the Power Supply printed circuit board. This battery can be replaced with power applied to the PLC.

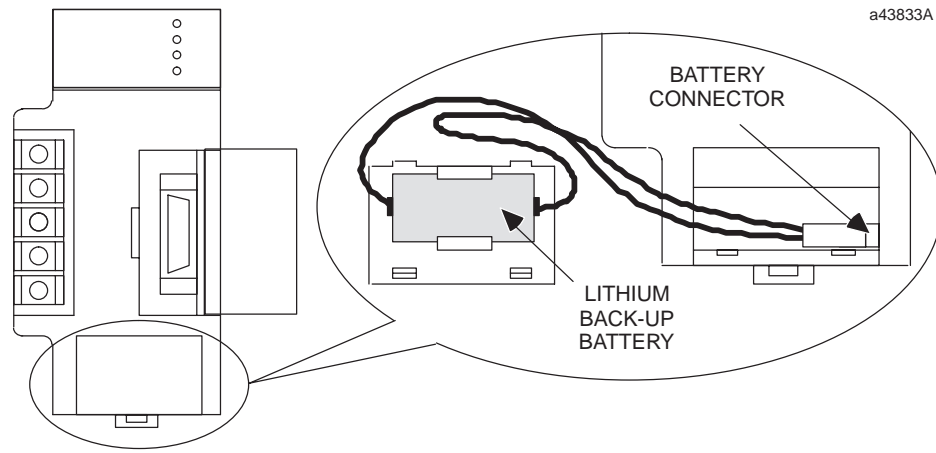

Figure 4-16. Backup Battery for RAM Memory

Caution

If a Low Battery Warning (BATT LED turns ON) occurs, replace the battery located in the power supply *before* removing power from the rack. Otherwise, there is a possibility that data will be corrupted or the application program will be cleared from memory.

Additional Battery Information

For additional information on the memory backup battery, see the chapter, “Memory Backup and Backup Battery” in the *Series 90–30 PLC Hardware and Installation Manual*, GFK–0356P (or later version).

Note

Only the battery in a power supply in a CPU rack is used for backing up CPU memory. A battery in a power supply mounted in an Expansion or Remote baseplate is not utilized.

Calculating Power Supply Loading

The load placed on a power supply in a Series 90-30 PLC baseplate is the sum of the internal and external loads placed on it by all of the hardware components in the baseplate (backplane, modules, etc.), as well as external loads connected to the Isolated + 24 VDC supply. Use of the Isolated +24 Volt power supply output is optional; however, this output can be used to drive a limited number of input devices. The maximum total power output rating of the Power Supplies is 30 watts; however, the individual +5VDC outputs can be rated for either 15 or 30 Watts, depending on the Power Supply catalog number. See Table 12-1, “Power Supply Feature Comparison Table,” for details.

Load Requirements for Hardware Components

The following table shows the DC load required by each module and hardware component. All ratings are in milliamps (except where noted). Input and Output module current ratings are with all inputs or outputs on. Three voltages are listed in the table:

- +5 VDC provides primary power to operate most internal circuits
- +24 VDC Relay Power provides power for circuits that drive the relays on Relay modules
- +24 VDC Isolated provides power to operate a number of input circuits (input modules only), and any external circuits connected to the 24 VDC Output terminals on the power supply terminal strip.

Note that the figures listed in the following table are maximum (worst case) requirements, not typical requirements.

Table 4-14. Load Requirements (in milliamps)

Catalog Number	Description	+5 VDC	+24 VDC Relay Power	+24 VDC Isolated
AD693SLP300	State Logic Processor Module	425	-	-
IC693ACC300	Input Simulator, 8/16 Points	120	-	-
IC693ACC307	Expansion Bus Termination Plug	72	-	-
IC690ACC900	RS-422/RS-485 to RS-232 Converter	170	-	-
IC690ACC901	RS-422 (SNP) to RS-232, Miniconverter Kit (Version A) (version B, or later) ‡	150 100	- -	- -
IC693ADC311	Alphanumeric Display Coprocessor Module	400	-	-
IC693ALG220	Analog Input, Voltage, 4 Channel	27	-	98
IC693ALG221	Analog Input, Current, 4 Channel	25	-	100
IC693ALG222	Analog Input, Voltage, High Density (16 Channel)	112	-	41
IC693ALG223	Analog Input, Current, High Density (16 Channel)	120	-	-
IC693ALG390	Analog Output, Voltage, 2 Channel	32	-	120
IC693ALG391	Analog Output, Current, 2 Channel	30	-	215
IC693ALG392	Analog Current/Voltage Output, 8 Channel	110	-	-
IC693ALG442	Analog Current/Voltage Combination 4 Ch In/2 Ch Out	95	-	129
IC693APU300	High Speed Counter	250	-	-
IC693APU301	Motion Mate APM300, 1-Axis	800	-	-
IC693APU302	Motion Mate APM300, 2-Axis	800	-	-
IC693APU305	I/O Processor Module	360	-	-
IC693BEM320	I/O Link Interface Module (slave)	205	-	-
IC693BEM321	I/O Link Interface Master Module (w/o optical adapter) (with Optical Adapter)	415 615	- -	- -
IC693BEM330	FIP Remote I/O Scanner	609	-	-
IC693BEM331	Genius Bus Controller	300	-	-
IC693BEM340	FIP Bus Controller (maximum) (typical)	1.2A 800	-	-
IC693CHS391	10-slot Modular CPU Baseplate	250	-	-
IC693CHS392	10-slot Expansion Baseplate	150	-	-
IC693CHS393	10-slot Remote Baseplate	460	-	-
IC693CHS397	5-slot Modular CPU Baseplate	270	-	-
IC693CHS398	5-slot Expansion Baseplate	170	-	-
IC693CHS399	5-slot Remote Baseplate	480	-	-
IC693CMM301	Genius Communications Module	200	-	-
IC693CMM302	Enhanced Genius Communications Module	300	-	-
IC693CMM311	Communications Control Module	400	-	-
IC693CMM321	Ethernet Interface Module	750	-	-
IC693CPU311	Series 90-30 5-Slot Embedded CPU Baseplate	410	-	-
IC693CPU313	Series 90-30 5-Slot Embedded CPU Baseplate	430	-	-
IC693CPU323	Series 90-30 10-Slot Embedded CPU Baseplate	430	-	-
IC693CPU331	CPU (Model 331)	350	-	-
IC693CPU340	CPU (Model 340)	490	-	-
IC693CPU341	CPU (Model 341)	490	-	-
IC693CPU350	CPU (Model 350)	670 ‡	-	-
IC693CPU351	CPU (Model 351)	890 ‡	-	-
IC693CPU352	CPU (Model 352)	910 ‡	-	-
IC693CPU360	CPU (Model 360)	670 ‡	-	-
IC693CPU363	CPU (Model 363)	890 ‡	-	-
IC693CPU364	CPU (Model 364)	1.51 A ‡	-	-
IC693CSE313	State Logic CPU, 5-slot baseplate	430	-	-
IC693CSE323	State Logic CPU, 10-slot baseplate	430	-	-

Catalog Number	Description	+5 VDC	+24 VDC Relay Power	+24 VDC Isolated
IC693CSE340	State Logic CPU Module	490	-	-
IC693DSM302/314	Motion Mate DSM302 or DSM314 Module	1.3A	-	-
IC693DVM300	Digital Valve Driver Module (doesn't connect to PLC backplane)	none	none	none
IC693MAR590	120 VAC Input, relay Output, 8 In/8 Out	80	70	-
IC693MDL230	120 VAC Isolated, 8 Point Input	60	-	-
IC693MDL231	240 VAC Isolated, 8 Point Input	60	-	-
IC693MDL240	120 VAC, 16 Point Input	90	-	-
IC693MDL241	24 VAC/DC Pos/Neg logic, 16 Point	80	-	125
IC693MDL310	120 VAC, 0.5A, 12 Point Output	210	-	-
IC693MDL330	120/240 VAC, 1A, 8 Point Output	160	-	-
IC693MDL340	120 VAC, 0.5A, 16 Point Output	315	-	-
IC693MDL390	120/240 VAC Isolated, 2A, 5 Point Output	110	-	-
IC693MDL630	24 VDC Positive Logic, 8 Point Input	2.5	-	60
IC693MDL632	125 VDC Pos/Neg Logic, 8 Point Input	40	-	-
IC693MDL633	24 VDC Negative Logic, 8 Point Input	5	-	60
IC693MDL634	24 VDC Pos/Neg Logic, 8 Point Input	80	-	125
IC693MDL640	24 VDC Positive Logic, 16 Point Input	5	-	120
IC693MDL641	24 VDC Negative Logic, 16 Point Input	5	-	120
IC693MDL643	24 VDC Positive Logic, FAST, 16 Point Input	5	-	120
IC693MDL644	24 VDC Negative Logic, FAST, 16 Point Input	5	-	120
IC693MDL645	24 VDC Pos/Neg Logic, 16 Point Input	80	-	125
IC693MDL646	24 VDC Pos/Neg Logic, FAST, 16 Point Input	80	-	125
IC693MDL652	24 VDC Pos/Neg Logic 32 Point Input	5	-	-
IC693MDL653	24 VDC Pos/Neg Logic, FAST, 32 Point Input	5	-	-
IC693MDL654	5/12 VDC (TTL) Pos/Neg Logic, 32 Point	195/440 †	-	-
IC693MDL655	24 VDC Pos/Neg, 32 Point Input	195	-	224
IC693MDL730	12/24 VDC Positive Logic, 2A, 8 Point Output	55	-	-
IC693MDL731	12/24 VDC Negative Logic, 2A, 8 Point Output	55	-	-
IC693MDL732	12/24 VDC Positive Logic, 0.5A, 8 Point Output	50	-	-
IC693MDL733	12/24 VDC Negative Logic, 0.5A, 8 Point Output	50	-	-
IC693MDL734	125 VDC Pos/Neg Logic, 6 Point Output	90	-	-
IC693MDL740	12/24 VDC Positive Logic, 0.5A, 16 Point Output	110	-	-
IC693MDL741	12/24 VDC Negative Logic, 0.5A, 16 Point Output	110	-	-
IC693MDL742	12/24 VDC Pos. Logic ESCP, 1A, 16 Point Output	130	-	-
IC693MDL750	12/24 VDC Negative Logic, 32 Point Output	21	-	-
IC693MDL751	12/24 VDC Positive Logic, 32 Point Output	21	-	-
IC693MDL752	5/24 VDC (TTL) Negative Logic, 0.5A, 32 Point	260	-	-
IC693MDL753	12/24 VDC Positive Logic, 0.5A, 32 Point Output	260	-	-
IC693MDL930	Relay, N.O., 4A Isolated, 8 Point Output	6	70	-
IC693MDL931	Relay, N.C. and Form C, 8A Isolated, 8 Point Out	6	110	-
IC693MDL940	Relay, N.O., 2A, 16 Point Output	7	135	-
IC693MDR390	24 VDC Input, Relay Output, 8 In/8 Out	80	70	-
IC693PCM300	Programmable Coprocessor Module, 65K	425	-	-
IC693PCM301	Programmable Coprocessor Module, 85K	425	-	-
IC693PCM311	Programmable Coprocessor Module, 380K	400	-	-
IC693PRG300	Hand-Held Programmer	170	-	-
IC693PTM100	Power Transducer Module	400	-	-
IC693TCM302/303	Temperature Control Module	150	-	-

† Refer to module specifications in Chapter 6 for more details.

‡ Note that the model 350–364 CPUs **do not** support the A version (IC690ACC901A) of the Miniconverter.

Power Supply Loading Calculation Examples

Following are examples of calculations for determining the total load placed on a Series 90-30 PLC power supply by the Series 90-30 PLC hardware. All current figures are expressed in milliamps. Note that although each output is rated at 15 or 20 watts (with the exception that the +5 VDC output for the High Capacity power supply is rated at 30 watts), the total combined output can be no more than 30 watts. The power required by external circuits connected to the 24 VDC OUTPUT terminals on the power supply terminal strip should be added to the calculation.

Example 1: Series 90-30, Model 323 Embedded CPU (10-slot baseplate)

Component	+5V	+24V Isolated	+24V Relay
IC693CPU323 Embedded CPU Baseplate	430		
IC693PRG300 Hand-Held Programmer	170		
IC693ALG390 Analog Output	32	120	
IC693ALG220 Analog Input	27	98	
IC693APU300 HS Counter	190		
24 VDC Input (16 points)	5	120	
IC693MDL340 Input Module	5	120	
IC693MDL740 Output Module	110		
IC693MDL240 Input Module	90		
IC693MDL310 Output Module	210		
IC693MDL940 Relay Out. Mod.	7		135
IC693MDL930 Relay Out. Mod.	6		70
Totals (milliamps) (Watts)	1281 6.41	458 10.99	205 4.92
Total Watts = 22.32			

Example 2: Series 90-30, Model 363 Modular CPU (10-slot baseplate)

Component	+5V	+24V Isolated	+24V Relay
IC693CHS391 Modular CPU Baseplate	250		
IC693CPU363 CPU Module	890		
IC690ACC901 Miniconverter Kit	100		
IC693PCM301 PCM Module	425		
IC693ALG390 Analog Output	32	120	
IC693ALG220 Analog Input	27	98	
IC693APU300 HS Counter	190		
IC693MDL340 Input Module	5	120	
IC693MDL740 Output Module	110		
IC693MDL240 Input Module	90		
IC693MDL310 Output Module	210		
IC693MDL940 Relay Out. Mod.	7		135
Totals (milliamps) (Watts)	2336 11.68	338 8.11	135 3.24
Total Watts = 23.03			

Chapter 5

General Discrete I/O Module Information

efesotomasyon.com

This chapter contains specifications and wiring information for Series 90-30 Discrete I/O modules. Modules are listed by module type: Input, Output, mixed Input/Output, and High-Density. Table 5-1 is an aid to locating discrete I/O module specifications and wiring information in this manual. Table 5-2 lists the load requirements for each I/O module.

I/O Module Specifications

The following three chapters contain specifications for each of the Series 90-30 discrete I/O modules. For each module, the following technical information is provided:

- Description of the module.
- List of specifications for the module.
- An illustration showing field wiring information, including appropriate user connections to the detachable terminal board or connector(s) and an example of the module's input or output circuitry for user interface information.
- Where applicable, a graph that provides temperature derating information for the module.

Please refer to the following table for a module overview and for a reference to the chapter where the module is discussed.

Table 5-1. Guide to Chapter Location for Discrete I/O Module Specifications

Catalog Number	Description of Module	Number of I/O Points	Chapter Number
IC693MDL230	Input - 120 VAC Isolated	8	6
IC693MDL231	Input - 240 VAC Isolated	8	6
IC693MDL240	Input - 120 VAC	16	6
IC693MDL241	Input - 24 VAC/DC Positive/Negative Logic	16	6
IC693MDL632	Input - 125 VDC Positive/Negative Logic	8	6
IC693MDL634	Input - 24 VDC Positive/Negative Logic	8	6
IC693MDL645	Input - 24 VDC Positive/Negative Logic	16	6
IC693MDL646	Input - 24 VDC Positive/Negative Logic, FAST	16	6
IC693ACC300	Input Simulator	8 or 16	6
IC693MDL310	Output - 120 VAC, 0.5A	12	7
IC693MDL330	Output - 120/240 VAC, 2A	8	7
IC693MDL340	Output - 120 VAC, 0.5A	16	7
IC693MDL390	Output - 120/240 VAC Isolated, 2A	5	7
IC693MDL730	Output - 12/24 VDC Positive Logic, 2A	8	7
IC693MDL731	Output - 12/24 VDC Negative Logic, 2A	8	7
IC693MDL732	Output - 12/24 VDC Positive Logic, 0.5A	8	7
IC693MDL733	Output - 12/24 VDC Negative Logic, 0.5A	8	7
IC693MDL734	Output - 125 VDC Positive/Negative Logic, 1A	6	7
IC693MDL740	Output - 12/24 VDC Positive Logic, 0.5A	16	7
IC693MDL741	Output - 12/24 VDC Negative Logic, 0.5A	16	7
IC693MDL742	Output - 12/24 VDC Positive Logic ESCP, 1A	16	7
IC693MDL930	Output - Relay, N.O., 4A Isolated	8	7
IC693MDL931	Output - Isolated Relay, N.C. and Form C, 8A	8	7
IC693MDL940	Output - Relay, N.O., 2A	16	7
IC693MAR590	Input/Output - 120 VAC Input, Relay Output	8/8	8
IC693MDR390	Input/Output - 24 VDC Input, Relay Output	8/8	8
IC693MDL653	Input - 24 VDC Positive/Negative Logic FAST	32	6
IC693MDL654	Input - 5/12 VDC (TTL) Positive/Negative Logic	32	6
IC693MDL655	Input - 24 VDC Positive/Negative Logic	32	6
IC693MDL750	Output - 12/24 VDC Negative Logic	32	7
IC693MDL751	Output - 12/24 VDC Positive Logic	32	7
IC693MDL752	Output - 5/24 VDC (TTL) Negative Logic, 0.5A	32	7
IC693MDL753	Output - 12/24 VDC Positive Logic, 0.5A	32	7

Discrete I/O Modules

Discrete I/O Module Point Density

There are two density categories for these modules:

- **Standard Density Modules:** Standard density modules have up to 16 circuits (also called “points”) per module. These modules are equipped with a removeable terminal board. See the following figure.
- **High Density Modules:** High density modules have 32 circuits per module. These modules have either a 50-pin connector, or two 24-pin connectors mounted on their faceplates. Connection choices are discussed later in this chapter.

Standard Density Discrete I/O Module Features

Standard Density (16 points or less) Modules have the following features (refer to the following figure):

- **Removeable Terminal Board.** You can remove the terminal board from the module in order to wire it, if desired. Then, when you are finished wiring it, you can easily reinstall it on the module. However, some prefer to leave it on the module when wiring. If you ever need to replace a module, you don’t have to do any rewiring if your old terminal board is still in good condition. Simply remove the wired terminal board from the old module and install it on the new module. The terminal board screw terminals are also convenient points for measuring voltages while testing or troubleshooting.
- **Hinged Front Cover.** The cover is easily opened to access the terminal board connections. Normally it’s kept closed to protect personnel from accidentally touching a hot terminal. Note in the following figure that the back side of the front cover insert contains a schematic diagram of the terminal board connections. The module catalog number (IC693MDL940 in the example shown) is printed on the bottom of the front cover insert. The module catalog number is also printed on the label on the side of the module. However, in order to see this side label, the module has to be removed from the PLC

On the front side of the front cover insert are lines that correspond to the module’s I/O points. You can temporarily remove the insert and write the signal name for each point on the appropriate line, as shown in the example in the figure.

Also on the front side of the front cover insert, running vertically on the left edge of the insert, is a color bar that identifies the type of module: Blue = DC, Red = AC, and Gray = Analog.

- **Module Lens Cap.** Located on the top front of the module, it covers the LED (Light Emitting Diode) status lights. These are labeled in the following figure in two groups, A1 through A8, and B1 through B8. Since this is a figure of a 16-Point Output module, there are 16 LED status lights. (The number of status lights on any given module is a function of the number of circuits points on that module.) If you compare these status lights to the connection diagram on the back of the hinged cover, you will notice that the outputs on this module are in two groups, labeled A1–A8 and B1–B8, that correspond to the A and B rows of status LEDs. Note the additional LED on the right side of the lens cap that is labeled with the letter F. This is a blown fuse indicator light. This letter F is present on all of the discrete I/O module lens caps, but is only functional on certain Output Modules that have internal fuses. It only lights if an internal fuse is blown. A table with a list of modules having fuses as well as other details about the status LEDs is provided in Chapter 13 of this manual.

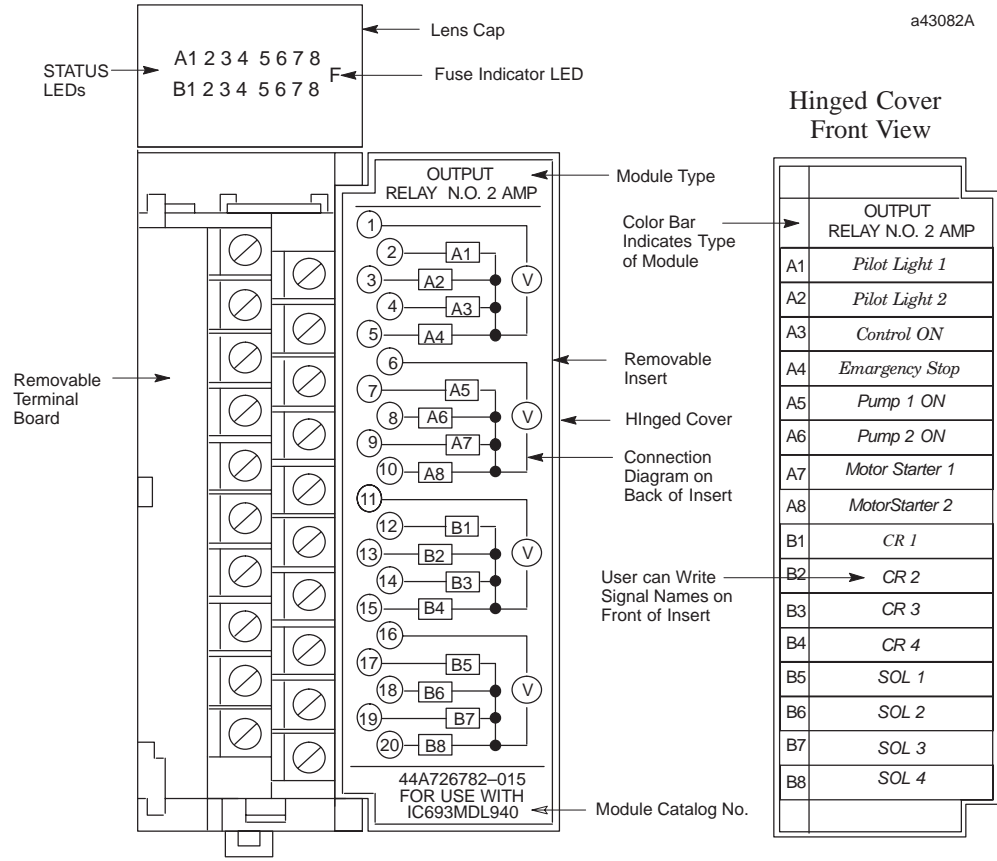

Figure 5-1. Example of Series 90-30 Standard Density Discrete Output Module

High Density (32-Point) Discrete Module Features

- There are two types of high density modules. One type has a single 50-pin connector on its faceplate, the other type has a pair of 24-pin connectors on its faceplate (see next two figures).
- The dual 24-pin type has LED status indicators. The 50-pin type does not. The LED status indicators are arranged in four groups of eight across, labeled A, B, C, and D. They are located at the top of the module (see next figure).
- 32-point modules are only available in 5, 12, and 24 VDC ratings.
- None of the 32-point modules are fused.
- These modules are useful in applications where a high count of DC I/O points is required. The maximum number of I/O points for a Series 90-30 system can be obtained by using a CPU that supports a total of eight 10-slot racks, and by populating the racks with 32-point modules. The theoretical maximum number of I/O points possible is calculated by adding the 9 available slots in the CPU rack (the CPU must occupy one slot) to the 70 slots in the seven 10-slot expansion or remote racks to get a total of 79 slots. Multiply 79 times 32 for a maximum of 2,528 I/O points (only CPUs 350 – 364 support this many I/O points). Of course, this assumes that every slot is populated with a 32-point I/O module. Most practical applications require that you use some slots for option modules, so the number of slots available for I/O modules will be reduced accordingly.

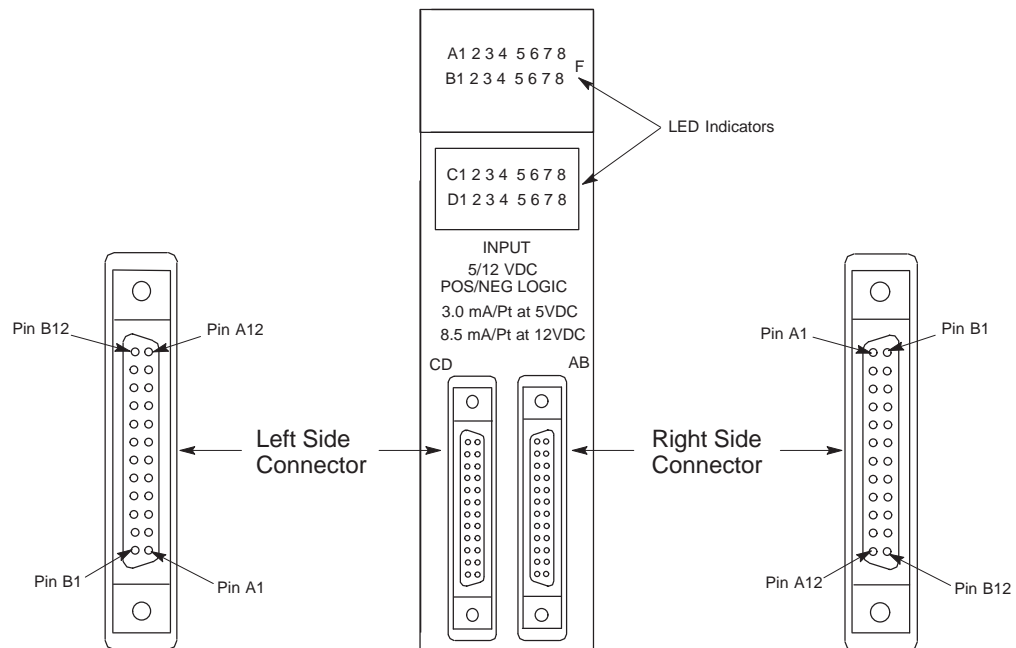

Figure 5-2. Example of 32-Point I/O Module (IC693MDL654) With Dual Connectors

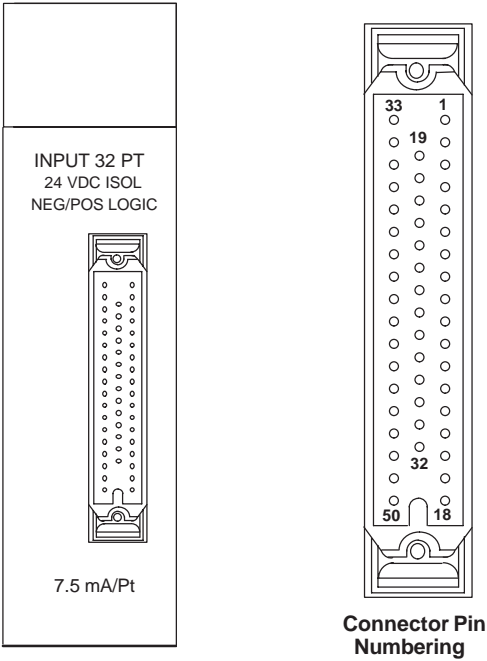

Figure 5-3. Example of 32-Point I/O Module (IC693MDL653) With Single Connector

Definition of Positive and Negative Logic

The IEC definitions for positive logic and negative logic, as applied to Series 90-30 I/O modules, are defined as follows.

Positive Logic - Input Modules

Input modules designed with positive logic characteristics sink current from the input device to the user common or negative power bus. The input device is connected between the positive power bus and the input terminal.

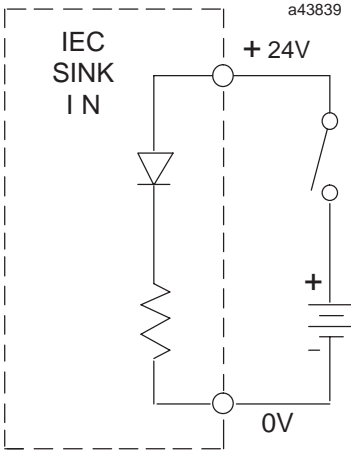

Positive Logic - Output Modules

Output modules designed with positive logic characteristics source current to the loads from the user common or positive power bus. The load is connected between the negative power bus and the module output.

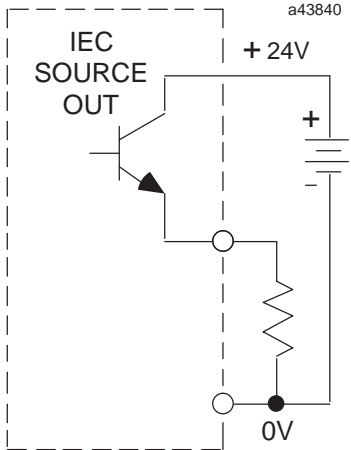

Negative Logic - Input Modules

Input modules designed with negative logic characteristics source current through the input device to the user common or positive power bus. The input device is connected between the negative power bus and the input terminal.

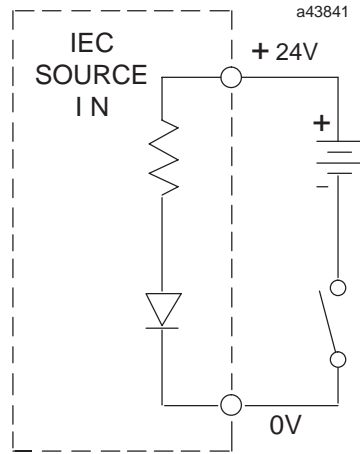

Negative Logic - Output Modules

Output modules designed with negative logic characteristics sink current from the loads to the user common or negative power bus. The load is connected between the positive power bus and the output terminal.

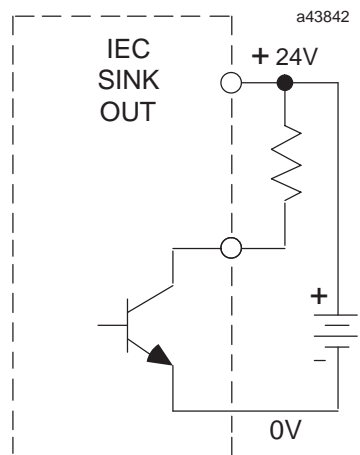

Chapter 6

Discrete Input Modules

efesotomasyon.com

120 Volt AC Isolated Input, 8 Point IC693MDL230

The **120 volt AC Isolated Input** module for the Series 90-30 Programmable Logic Controller provides 8 isolated input points, each with a common power input terminal. The input circuits are reactive (resistor/capacitor) inputs. Current into an input point results in a logic 1 in the input status table (%I). Input characteristics are compatible with a wide range of user-supplied input devices, such as pushbuttons, limit switches, and electronic proximity switches. Power to operate the field devices must be supplied by the user. This module requires an AC power source, *it cannot be used with a DC power source.*

LED indicators which provide the ON/OFF status of each point are located at the top of the module. This LED block has a horizontal row with eight green LEDs labeled A1 through 8 (points 1 through 8). An insert goes between the inside and outside surface of the hinged door. The surface towards the inside of the module (when the hinged door is closed) has circuit wiring information, and circuit identification information can be recorded on the outside surface. The outside left edge of the insert is color-coded red to indicate a high-voltage module. This module can be installed in any I/O slot of a 5 or 10-slot baseplate in a Series 90-30 PLC system.

Table 6-1. Specifications for IC693MDL230

Rated Voltage	120 volts AC, 50/60 Hz
Input Voltage Range	0 to 132 volts AC, 50/60 Hz
Inputs per Module	8 (each input point has a separate common)
Isolation	1500 volts RMS between field side and logic side 500 volts RMS between inputs
Input Current	14.5 mA (typical) at rated voltage
Input Characteristics:	
On-state Voltage	74 to 132 volts AC
Off-state Voltage	0 to 20 volts AC
On-state Current	6 mA minimum
Off-state Current	2.2 mA maximum
On response Time	30 ms maximum
Off response Time	45 ms maximum
Power Consumption	60 mA (all inputs on) from 5 volt bus on backplane

Refer to Appendix B for product standards and general specifications.

IC693MDL230 Input Module Field Wiring Information

The following figure provides wiring information for connecting user supplied input devices and power source to the 120 volt AC Isolated input module. Note that since each input is isolated (separate) from each of the other inputs, each input can be powered by a separate AC power source.

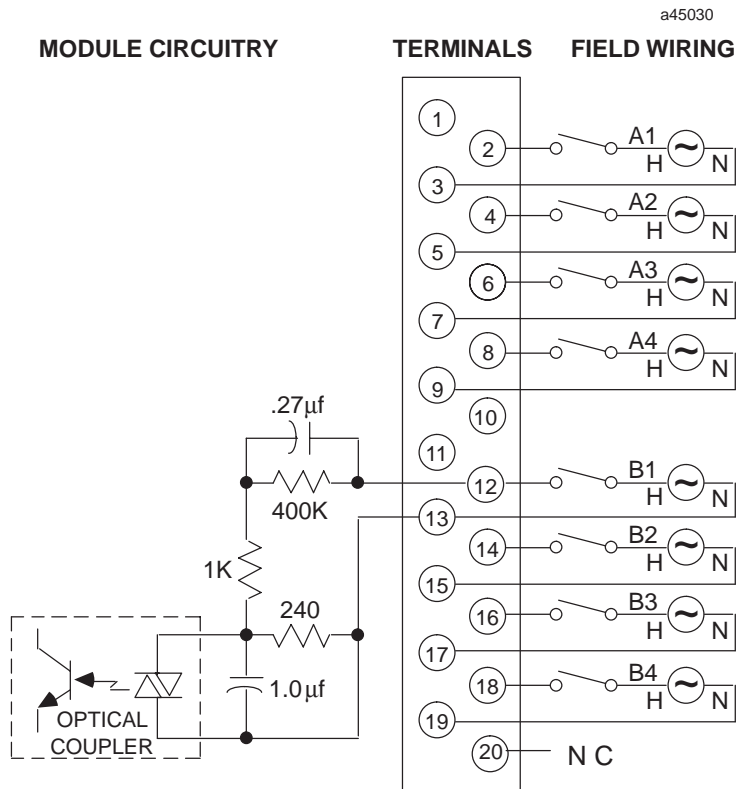

Figure 6-1. Field Wiring - 120 Volt AC Isolated Input Module - IC693MDL230

240 Volt AC Isolated Input, 8 Point IC693MDL231

The **240 volt AC Isolated Input** module for the Series 90-30 Programmable Logic Controller provides 8 isolated input points, each with a common power input terminal. The input circuits are reactive (resistor/capacitor) inputs. Current into an input point results in a logic 1 in the input status table (%I). Input characteristics are compatible with a wide range of user-supplied input devices, such as pushbuttons, limit switches, and electronic proximity switches. Power to operate the field devices must be supplied by the user. This module requires an AC power source, *it cannot be used with a DC power source.*

LED indicators which provide the ON/OFF status of each point are located at the top of the module. This LED block has a horizontal row with eight green LEDs labeled A1 through 8 (points 1 through 8). An insert goes between the inside and outside surface of the hinged door. The surface towards the inside of the module (when the hinged door is closed) has circuit wiring information, and circuit identification information can be recorded on the outside surface. The outside left edge of the insert is color-coded red to indicate a high-voltage module.

This module can be installed in any I/O slot of a 5 or 10-slot baseplate in a Series 90-30 PLC system.

Table 6-2. Specifications for IC693MDL231

Rated Voltage	240 volts AC, 50/60 Hz
Input Voltage Range	0 to 264 volts AC, 50/60 Hz
Inputs per Module	8 (each input point has a separate common)
Isolation	1500 volts RMS between field side and logic side 500 volts RMS between inputs
Input Current	15 mA (typical) at rated voltage
Input Characteristics:	
On-state Voltage	148 to 264 volts AC
Off-state Voltage	0 to 40 volts AC
On-state Current	6 mA minimum
Off-state Current	2.2 mA maximum
On response Time	30 ms maximum
Off response Time	45 ms maximum
Power Consumption	60 mA (all inputs on) from 5 volt bus on backplane

Refer to Appendix B for product standards and general specifications.

IC693MDL231 Input Module Field Wiring Information

The following figure provides wiring information for connecting user supplied input devices and power source to the 240 volt AC Isolated input module. Note that since each input is isolated (separate) from each of the other inputs, each input can be powered by a separate AC power source.

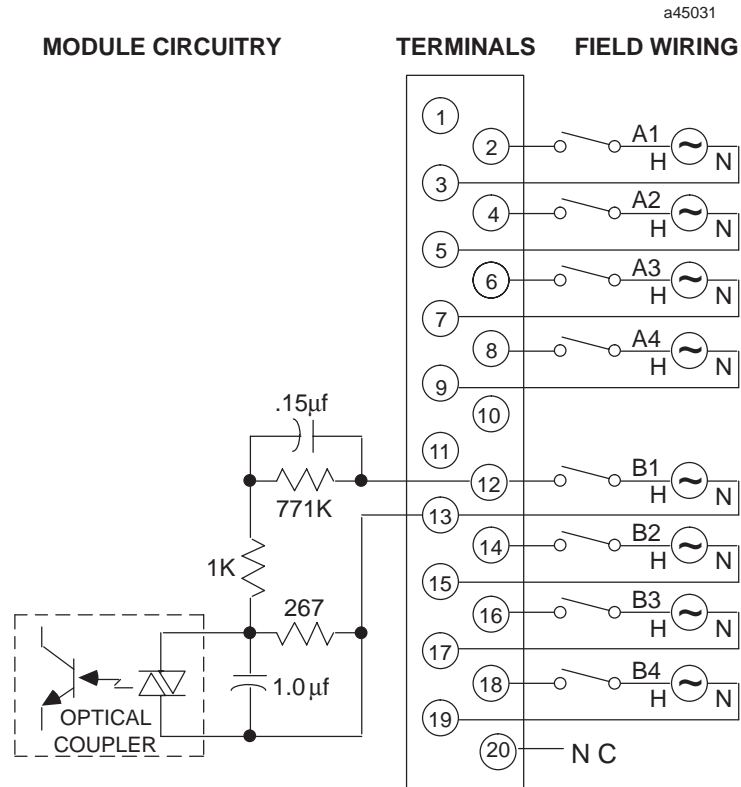

Figure 6-2. Field Wiring - 240 Volt AC Isolated Input Module - IC693MDL231

120 Volt AC Input, 16 Point IC693MDL240

The **120 volt AC Input** module for the Series 90-30 Programmable Logic Controller provides 16 input points with one common power input terminal. The input circuits are reactive (resistor/capacitor) inputs. Current into an input point results in a logic 1 in the input status table (%I). Input characteristics are compatible with a wide range of user-supplied input devices, such as pushbuttons, limit switches, and electronic proximity switches. Power to operate the field devices must be supplied by the user. This module requires an AC power source, *it cannot be used with a DC power source.*

LED indicators which provide the ON/OFF status of each point are located at the top of the module. This LED block has two horizontal rows with eight green LEDs in each row; the top row labeled A1 through 8 (points 1 through 8) and the bottom row labeled B1 through 8 (points 9 through 16). An insert goes between the inside and outside surface of the hinged door. The surface towards the inside of the module (when the hinged door is closed) has circuit wiring information, and circuit identification information can be recorded on the outside surface. The outside left edge of the insert is color-coded red to indicate a high-voltage module. This module can be installed in any I/O slot of a 5 or 10-slot baseplate in a Series 90-30 PLC system.

Table 6-3. Specifications for IC693MDL240

Rated Voltage	120 volts AC
Input Voltage Range	0 to 132 volts AC, 50/60 Hz
Inputs per Module[†]	16 (one group with a single common)
Isolation	1500 volts RMS between field side and logic side
Input Current	12 mA (typical) at rated voltage
Input Characteristics:	
On-state Voltage	74 to 132 volts AC
Off-state Voltage	0 to 20 volts AC
On-state Current	6 mA minimum
Off-state Current	2.2 mA maximum
On response Time	30 ms maximum
Off response Time	45 ms maximum
Consumption	90 mA (all inputs on) from 5 volt bus on backplane

[†] Number of inputs on is dependent upon ambient temperature as shown in figure 6-7.

Refer to Appendix B for product standards and general specifications.

IC693MDL240 Input Module Field Wiring Information

The following figure provides wiring information for connecting user supplied input devices and power source to the 120 volt AC input module.

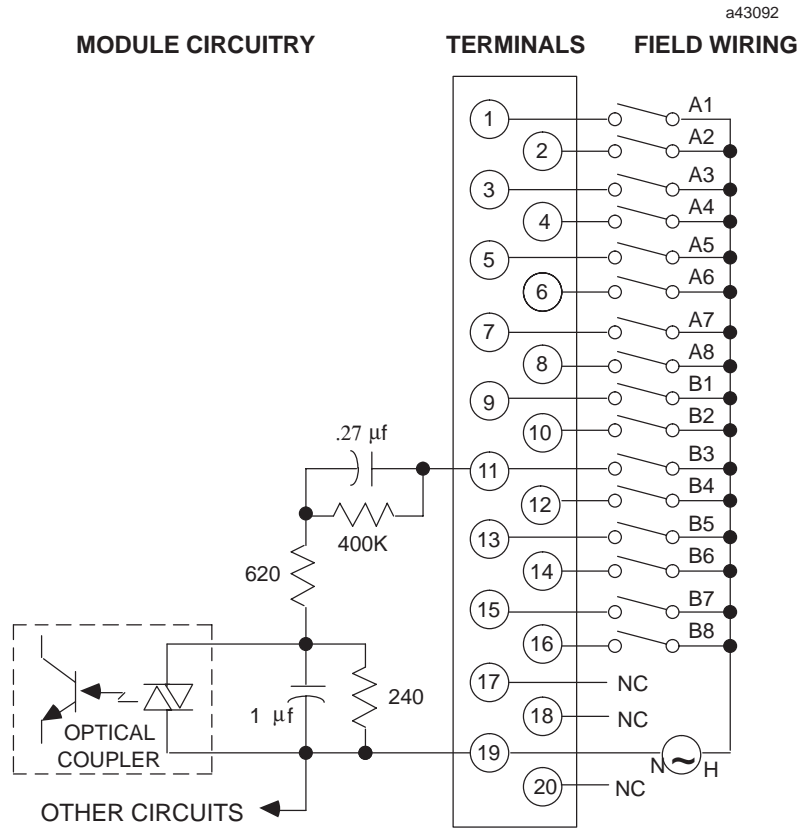

Figure 6-3. Field Wiring - 120 Volt AC Input Module - IC693MDL240

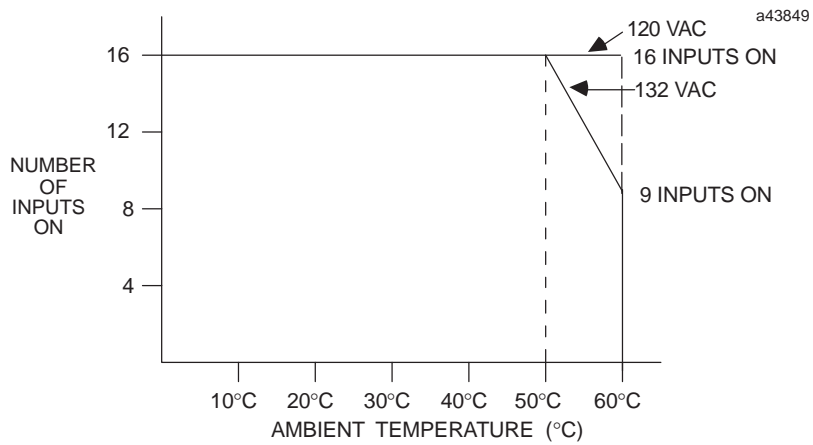

Figure 6-4. Input Points vs. Temperature for IC693MDL240

24 Volt AC/DC Positive/Negative Logic Input, 16 Point IC693MDL241

The *24 volt AC/DC Positive/Negative Input* module for the Series 90-30 Programmable Logic Controller provides 16 input points in one group with a common power input terminal. This input module is designed to have either positive or negative logic characteristics in the DC input mode. This input module is designed to function with AC or DC user inputs. Input characteristics are compatible with a wide range of user-supplied input devices, such as pushbuttons, limit switches, and electronic proximity switches. Current into an input point results in a logic 1 in the input status table (%I). Power to operate the field devices can be supplied by the user, or the Isolated +24 VDC output on the power supply (bottom two power supply terminals) can be used to power a limited number of DC inputs.

LED indicators which provide the ON/OFF status of each point are located at the top of the module. This LED block has two horizontal rows with eight green LEDs in each row; the top row labeled A1 through 8 (points 1 through 8) and the bottom row labeled B1 through 8 (points 9 through 16). An insert goes between the inside and outside surface of the hinged door. The surface towards the inside of the module (when the hinged door is closed) has circuit wiring information, and circuit identification information can be recorded on the outside surface. The outside left edge of the insert is color-coded blue to indicate a low-voltage module. This module can be installed in any I/O slot of a 5 or 10-slot baseplate in a Series 90-30 PLC system.

Table 6-4. Specifications for IC693MDL241

Rated Voltage	24 volts AC or 24 volts DC
Input Voltage Range	0 to +30 volts DC or 0 to +30 volts AC, 50/60 Hz
Inputs per Module †	16 (one group with a single common)
Isolation	1500 volts between field side and logic side
Input Current	7 mA (typical) at rated voltage
Input Characteristics	
On-state Voltage	11.5 to 30 volts AC or DC
Off-state Voltage	0 to +4 volts AC or DC
On-state Current	3.2 mA minimum
Off-state Current	1 mA maximum
On response Time	12 ms typical
Off response Time	28 ms typical
Power Consumption: 5V	80 mA (all inputs on) from 5 volt bus on backplane
Power Consumption: 24V	125 mA from the Isolated 24 volt backplane bus or from user supplied power

† Number of inputs on is dependent upon ambient temperature as shown in figure 6-9.

Refer to Appendix B for product standards and general specifications.

IC693MDL241 Input Module Field Wiring Information

The following figure provides wiring information for connecting user supplied input devices and power source to the 24 volt AC/DC positive/negative logic input module.

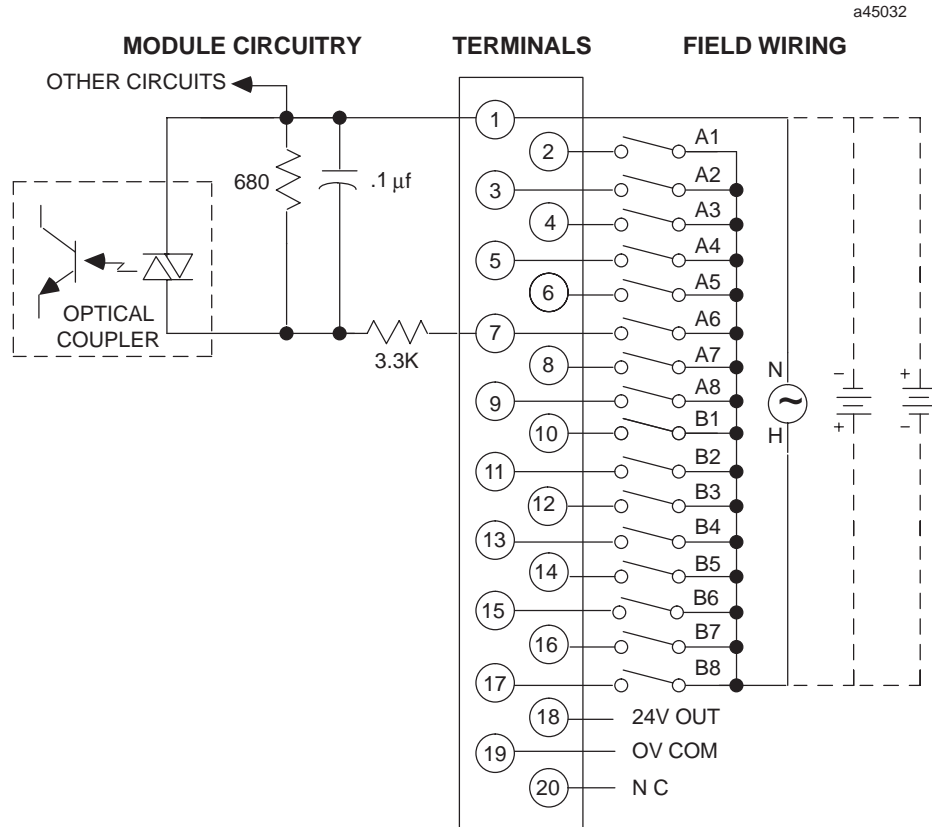

Figure 6-5. Field Wiring - 24 Volt AC/DC Pos/Neg Logic Input Module - IC693MDL241

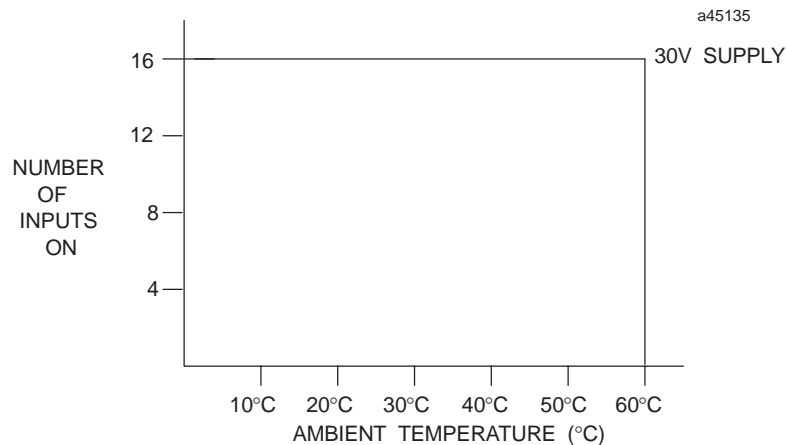

Figure 6-6. Input Points vs. Temperature for IC693MDL241

125 Volt DC Positive/Negative Logic Input, 8 Point IC693MDL632

This *125 volt DC Positive/Negative Logic Input* module provides 8 input points in two isolated groups with four points in each group. Each group has a separate common associated with it (the two commons are not tied together inside the module). The input module is designed to have either positive logic characteristics in that it sinks current from the input devices to the user common or negative power bus, or negative logic characteristics in that it sources current through the input devices to the user common or positive power bus. The input device is connected between the power bus and the module input. Current into an input point results in a logic 1 in the input status table (%I). Input characteristics are compatible with a wide range of input devices, such as pushbuttons, limit switches, and electronic proximity switches. Power to operate field devices must be supplied by the user.

LED indicators which provide the ON/OFF status of each point are located at the top of the module. This LED block has two horizontal rows with eight green LEDs in each row. This module uses the top row labeled A1 through 8 (points 1 through 8). An insert goes between the inside and outside surface of the hinged door. The surface towards the inside of the module (when the hinged door is closed) has circuit wiring information, and circuit identification information can be recorded on the outside surface. The outside left edge of the insert is color-coded red to indicate a high-voltage module.

This module can be installed in any I/O slot of a 5 or 10-slot baseplate in a Series 90-30 PLC system.

Table 6-5. Specifications for IC693MDL632

Rated Voltage	125 volts DC (Positive or Negative Logic)
Input Voltage Range	0 to +150 volts DC
Inputs per Module †	8 (two groups of four inputs)
Isolation	1500 volts between field side and logic side 500 volts between groups
Input Current	4.5 mA typical
Input Characteristics	
On-state Voltage	90 to 150 volts DC
Off-state Voltage	0 to 30 volts DC
On-state Current	3.1 mA
Off-state Current	1.1 mA maximum
On response Time	7 ms typical
Off response Time	7 ms typical
Internal Power Consumption	40 mA from the 5 volt bus on the backplane 36 mA (typical) from user input supply (all inputs ON)

† Number of inputs on is dependent upon ambient temperature as shown in figure 6-11.

Refer to Appendix B for product standards and general specifications.

IC693MDL632 Input Module Field Wiring Information

The following figure provides wiring information for connecting user supplied input devices and power source to the 125 volt DC positive/negative logic input module. The negative logic connections are shown in dashed lines.

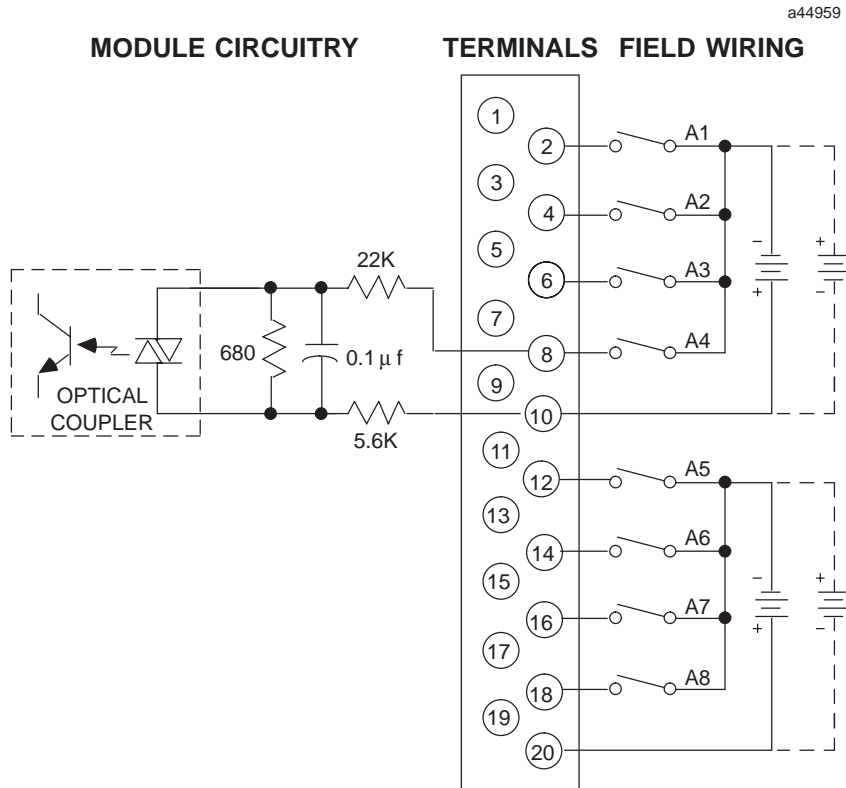

Figure 6-7. Field Wiring - 125 Volt DC Positive /Negative Logic Input Module - IC693MDL632

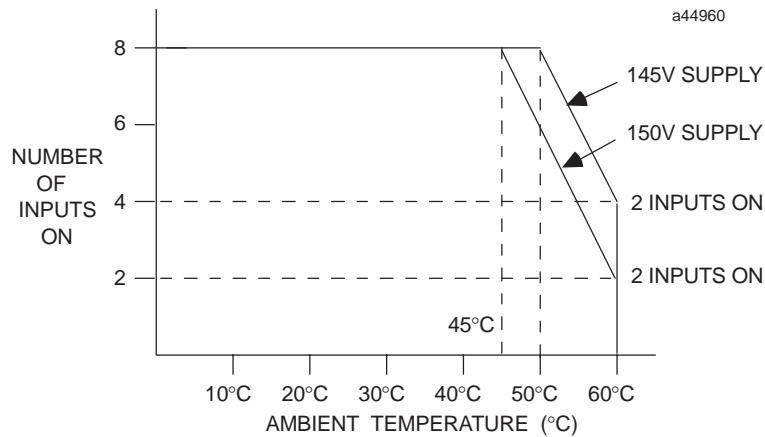

Figure 6-8. Input Points vs. Temperature for IC693MDL632

24 Volt DC Positive/Negative Logic Input, 8 Point IC693MDL634

The *24 volt DC Positive/Negative Logic Input* module for the Series 90-30 Programmable Logic Controller provides 8 input points in one group with a common power input terminal. This input module is designed to have either positive logic or negative logic characteristics. Input characteristics are compatible with a wide range of user-supplied input devices, such as pushbuttons, limit switches, and electronic proximity switches. Current into an input point results in a logic 1 in the input status table (%I). Power to operate the field devices can be supplied by the user, or an Isolated +24 VDC supply on the power supply (+24V OUT and 0V OUT terminals) can power a limited number of inputs.

LED indicators which provide the ON/OFF status of each point are located at the top of the module. This LED block has two horizontal rows with eight green LEDs in each row; the top row labeled A1 through 8 (points 1 through 8) is used by this module. An insert goes between the inside and outside surface of the hinged door. The surface towards the inside of the module (when the hinged door is closed) has circuit wiring information, and circuit identification information can be recorded on the outside surface. The outside left edge of the insert is color-coded blue to indicate a low-voltage module. This module can be installed in any I/O slot of a 5 or 10-slot baseplate in a Series 90-30 PLC system.

Table 6-6. Specifications for IC693MDL634

Rated Voltage	24 volts DC
Input Voltage Range	0 to +30 volts DC
Inputs per Module	8 (one group with a single common)
Isolation	1500 volts between field side and logic side
Input Current	7 mA (typical) at rated voltage
Input Characteristics	
On-state Voltage	11.5 to 30 volts DC
Off-state Voltage	0 to +5 volts DC
On-state Current	3.2 mA minimum
Off-state Current	1.1 mA maximum
On response Time	7 ms typical
Off response Time	7 ms typical
Power Consumption: 5V	45 mA (all inputs on) from 5 volt bus on backplane
Power Consumption: 24V	62 mA from the Isolated 24 volt backplane bus or from user supplied power

Refer to Appendix B for product standards and general specifications.

IC693MDL634 Input Module Field Wiring Information

The following figure provides wiring information for connecting user supplied input devices and power source to the 24 volt DC positive/negative logic input module.

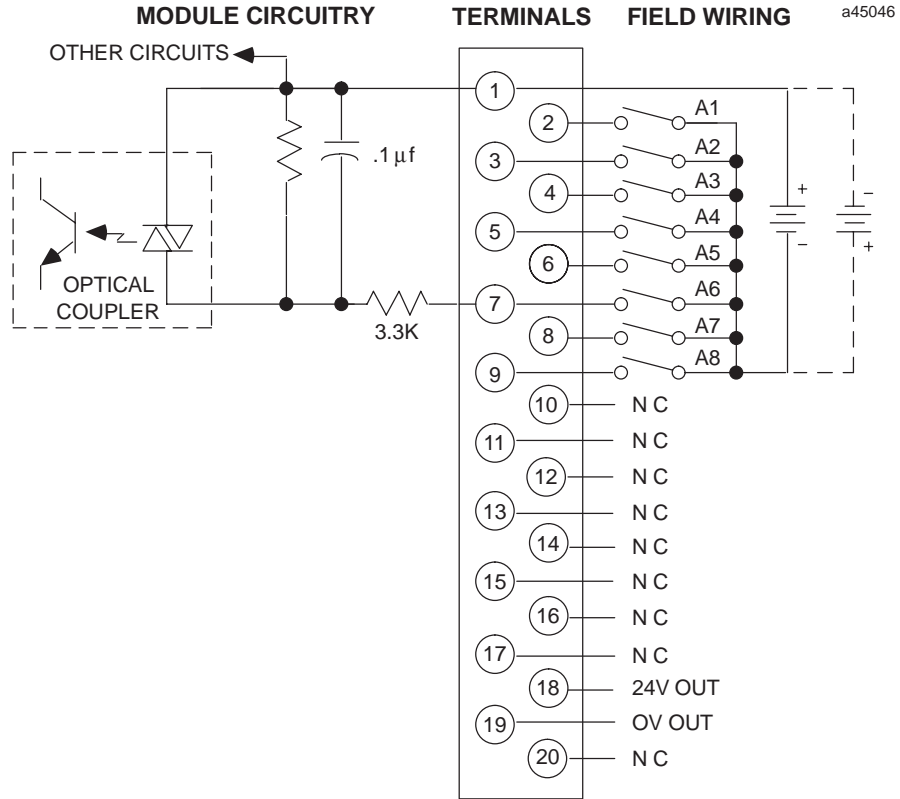

Figure 6-9. Field Wiring - 24 Volt Positive/Negative Logic Input Module - IC693MDL634

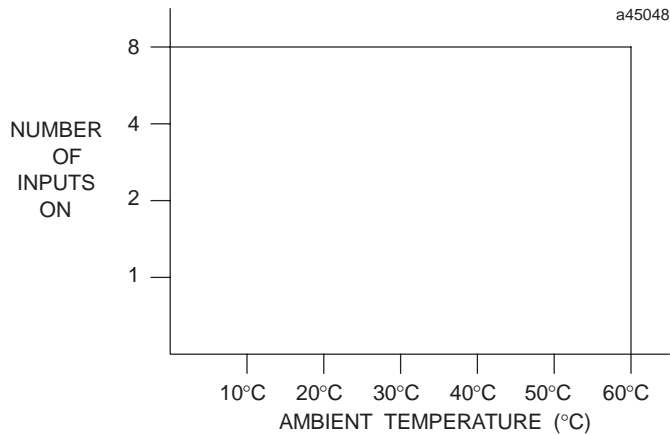

Figure 6-10. Input Points vs. Temperature for IC693MDL634

24 Volt DC Positive/Negative Logic Input, 16 Point IC693MDL645

The *24 volt DC Positive/Negative Logic Input* module for the Series 90-30 Programmable Logic Controller provides 16 input points in one group with a common power input terminal. This input module is designed to have either positive logic or negative logic characteristics. Input characteristics are compatible with a wide range of user-supplied input devices, such as pushbuttons, limit switches, and electronic proximity switches. Current into an input point results in a logic 1 in the input status table (%I). Power to operate the field devices can be supplied by the user, or an Isolated +24 VDC supply on the power supply (+24V OUT and 0V OUT terminals) can power a limited number of inputs.

LED indicators which provide the ON/OFF status of each point are located at the top of the module. This LED block has two horizontal rows with eight green LEDs in each row; the top row labeled A1 through 8 (points 1 through 8) and the bottom row labeled B1 through 8 (points 9 through 16). An insert goes between the inside and outside surface of the hinged door. The surface towards the inside of the module (when the hinged door is closed) has circuit wiring information, and circuit identification information can be recorded on the outside surface. The outside left edge of the insert is color-coded blue to indicate a low-voltage module. This module can be installed in any I/O slot of a 5 or 10-slot baseplate in a Series 90-30 PLC system.

Table 6-7. Specifications for IC693MDL645

Rated Voltage	24 volts DC
Input Voltage Range	0 to +30 volts DC
Inputs per Module	16 (one group with a single common)
Isolation	1500 volts between field side and logic side
Input Current	7 mA (typical) at rated voltage
Input Characteristics	
On-state Voltage	11.5 to 30 volts DC
Off-state Voltage	0 to +5 volts DC
On-state Current	3.2 mA minimum
Off-state Current	1.1 mA maximum
On response Time	7 ms typical
Off response Time	7 ms typical
Power Consumption: 5V	80 mA (all inputs on) from 5 volt bus on backplane
Power Consumption: 24V	125 mA from the Isolated 24 volt backplane bus or from user supplied power

Refer to Appendix B for product standards and general specifications.

IC693MDL645 Input Module Field Wiring Information

The following figure provides wiring information for connecting user supplied input devices and power source to the 24 volt DC positive/negative logic input module.

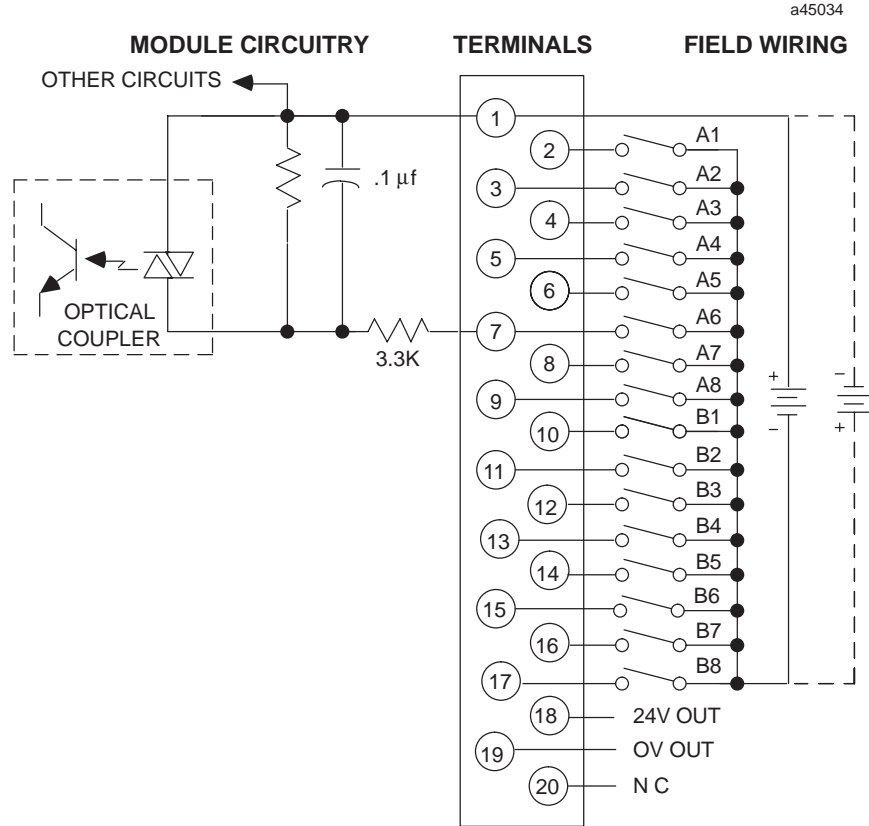

Figure 6-11. Field Wiring - 24 Volt DC Positive/Negative Logic Input Module - IC693MDL645

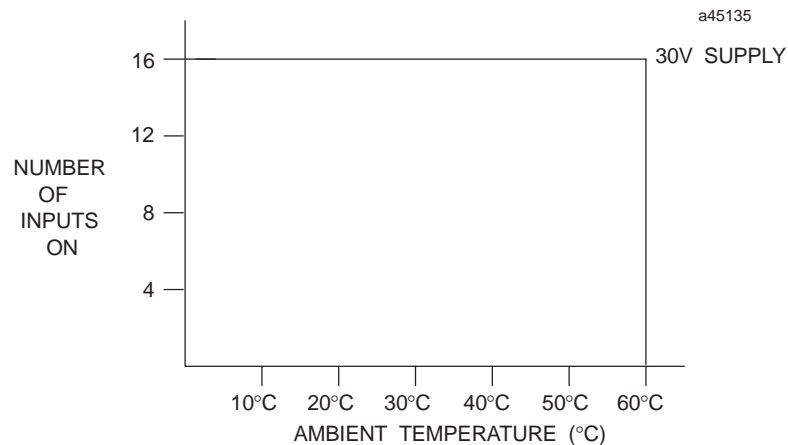

Figure 6-12. Input Points vs. Temperature for IC693MDL645

24 Volt DC Positive/Negative Logic Input, 16 Point IC693MDL646

This **24 volt DC Positive/Negative Logic Input** module for the Series 90-30 Programmable Logic Controller provides 16 input points in one group with a common power input terminal. *The on and off response times for this module are typically 1 ms.* This input module is designed to have either positive logic or negative logic characteristics. Input characteristics are compatible with a wide range of user-supplied input devices, such as pushbuttons, limit switches, and electronic proximity switches. Current into an input point results in a logic 1 in the input status table (%I). Power to operate the field devices can be supplied by the user, or an Isolated +24 VDC supply on the power supply (+24V OUT and 0V OUT terminals) can power a limited number of inputs.

LED indicators which provide the ON/OFF status of each point are located at the top of the module. This LED block has two horizontal rows with eight green LEDs in each row; the top row labeled A1 through 8 (points 1 through 8) and the bottom row labeled B1 through 8 (points 9 through 16). An insert goes between the inside and outside surface of the hinged door. The surface towards the inside of the module (when the hinged door is closed) has circuit wiring information, and circuit identification information can be recorded on the outside surface. The outside left edge of the insert is color-coded blue to indicate a low-voltage module. This module can be installed in any I/O slot in a Series 90-30 PLC system.

Table 6-8. Specifications for IC693MDL646

Rated Voltage	24 volts DC
Input Voltage Range	0 to +30 volts DC
Inputs per Module	16 (one group with a single common)
Isolation	1500 volts between field side and logic side
Input Current	7 mA (typical) at rated voltage
Input Characteristics	
On-state Voltage	11.5 to 30 volts DC
Off-state Voltage	0 to +5 volts DC
On-state Current	3.2 mA minimum
Off-state Current	1.1 mA maximum
On response Time	1 ms typical
Off response Time	1 ms typical
Power Consumption: 5V	80 mA (all inputs on) from 5 volt bus on backplane
Power Consumption: 24V	125 mA from the Isolated 24 volt backplane bus or from user supplied power

Refer to Appendix B for product standards and general specifications.

IC693MDL646 Input Module Field Wiring Information

The following figure provides wiring information for connecting user supplied input devices and power source to the 24 volt DC positive/negative logic input module.

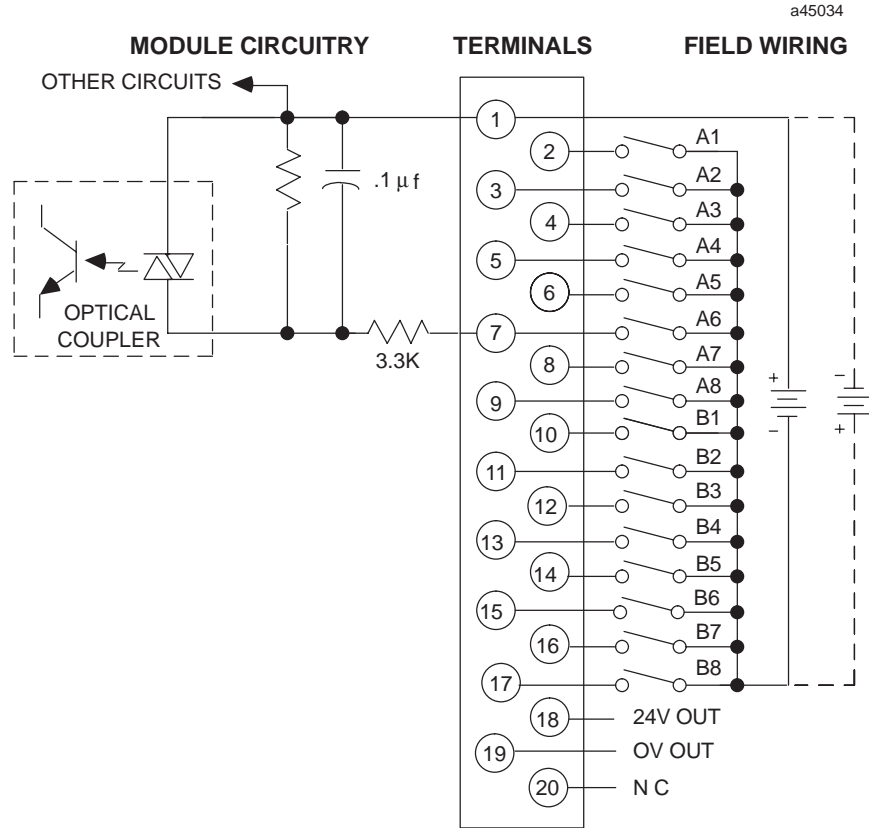

Figure 6-13. Field Wiring - 24 Volt DC Pos/Neg Logic Input Module - IC693MDL646

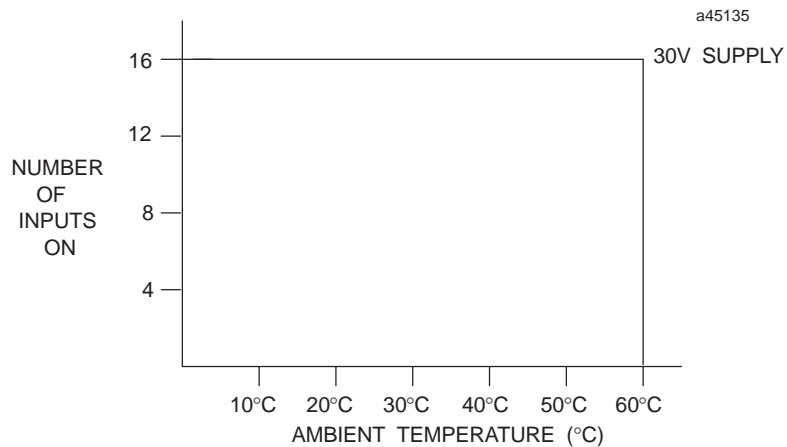

Figure 6-14. Input Points vs. Temperature for IC693MDL646

Input Simulator, 8/16 Point IC693ACC300

The *Input Simulator* module for the Series 90-30 Programmable Logic Controller has 16 two-position switches on the front of the module. Each switch can be programmed as a discrete input device. This module allows simulation of either 8 point or 16 point input modules. A switch, located in the rear of the module, allows configuration of the module for either 8 or 16 points. When the mode switch is set for 8 points, only the first 8 switches can be used. A switch in the ON position results in a logic 1 in the input table (%I). This module requires no field connections. The Input Simulator is a valuable tool when developing programs and troubleshooting since it can be substituted for actual inputs until the program or system is debugged. It can also remain permanently in the system to provide 8 or 16 conditional input contacts for manual control of output devices.

There are two rows of green LED indicators which correspond to the position of each switch. The corresponding LED turns ON when the switch is placed in the ON position, and is OFF when the switch is in the OFF position. The LEDs are arranged in two rows with 8 LEDs in each row. The top row is labeled A1 through A8, and the bottom row is labeled B1 through B8.

This module can be installed in any I/O slot of a 5 or 10-slot baseplate in a Series 90-30 PLC system.

Table 6-9. Specifications for IC693ACC300

Inputs per Module	8 or 16 (switch selectable)
Off Response Time	20 milliseconds maximum
On Response Time	30 milliseconds maximum
Internal Power Consumption	120 mA (all inputs on) from 5 volt bus on backplane

Refer to Appendix B for product standards and general specifications.

The Input Simulator module does not require any field wiring - just set the mode switch on the back of the module to 8 or 16 and install the module in the selected I/O slot in a baseplate. An illustration of the module is shown in the following figure.

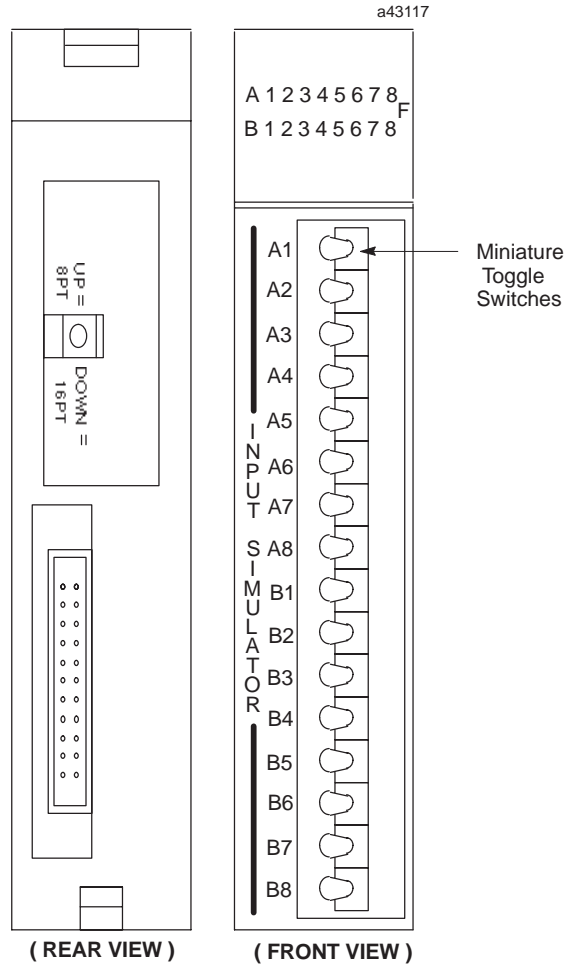

Figure 6-15. IC693ACC300 Input Simulator Module

24 VDC Positive/Negative Logic, 32 Point Input IC693MDL653

This **24 volt DC Positive/Negative Logic Input** module for the Series 90-30 Programmable Logic Controller provides 32 input points in four isolated groups with eight points in each group. Each group has two common pins associated with it, which are tied together internally. The On and Off response times for this module are 2 milliseconds maximum. This input module is designed to have both positive and negative logic characteristics. When connected for positive logic, it sinks current from the input device to the user common or negative power bus. The input device is connected between the positive power bus and the circuit input. When connected for negative logic, it sources current through the input device to the user common or positive power bus. The input device is connected between the negative power bus and the circuit input. Current into an input point results in a logic 1 in the input status table (%I).

Input characteristics are compatible with a wide range of input devices, such as pushbuttons, limit switches, and electronic proximity switches. Power to operate field devices must be supplied by the user.

Connections to the input circuits are made from the user's input devices to a 50-pin connector mounted on the front of the module. Prewired cables having a mating connector on one end and the wires on the opposite end terminated with terminal lugs are available from GE Fanuc.

This module does not have LED indicators to indicate circuit status. This module can be installed in any I/O slot of a 5 or 10-slot baseplate in a Series 90-30 PLC system.

Table 6-10. Specification for IC693MDL653

Rated Voltage	24 volts DC
Input Voltage Range	24 volts DC (+10%, -20%)
Inputs per Module[†]	32 (four groups with two commons per group)
Isolation	1500 volts between field side and logic side
Input Current	7.5 mA (average) at rated voltage
Input Characteristics	
On-state Voltage	15 volts DC minimum
Off-state Voltage	6 volts DC maximum
On-state Current	4.5 mA minimum
Off-state Current	2 mA maximum
On response Time	2 ms maximum
Off response Time	2 ms maximum
Internal Power Consumption	5 mA (16 inputs on) from 5 volt bus on the backplane

[†] The maximum number of inputs turned on at the same time should be limited to 16 or less.
Refer to data sheet GFK-0867C, or later revision for product standards and general specifications.

IC693MDL653 Input Module Field Wiring Information

The following figure provides wiring information for connecting user supplied input devices and power source to the 24 volt DC positive/negative logic, FAST input module.

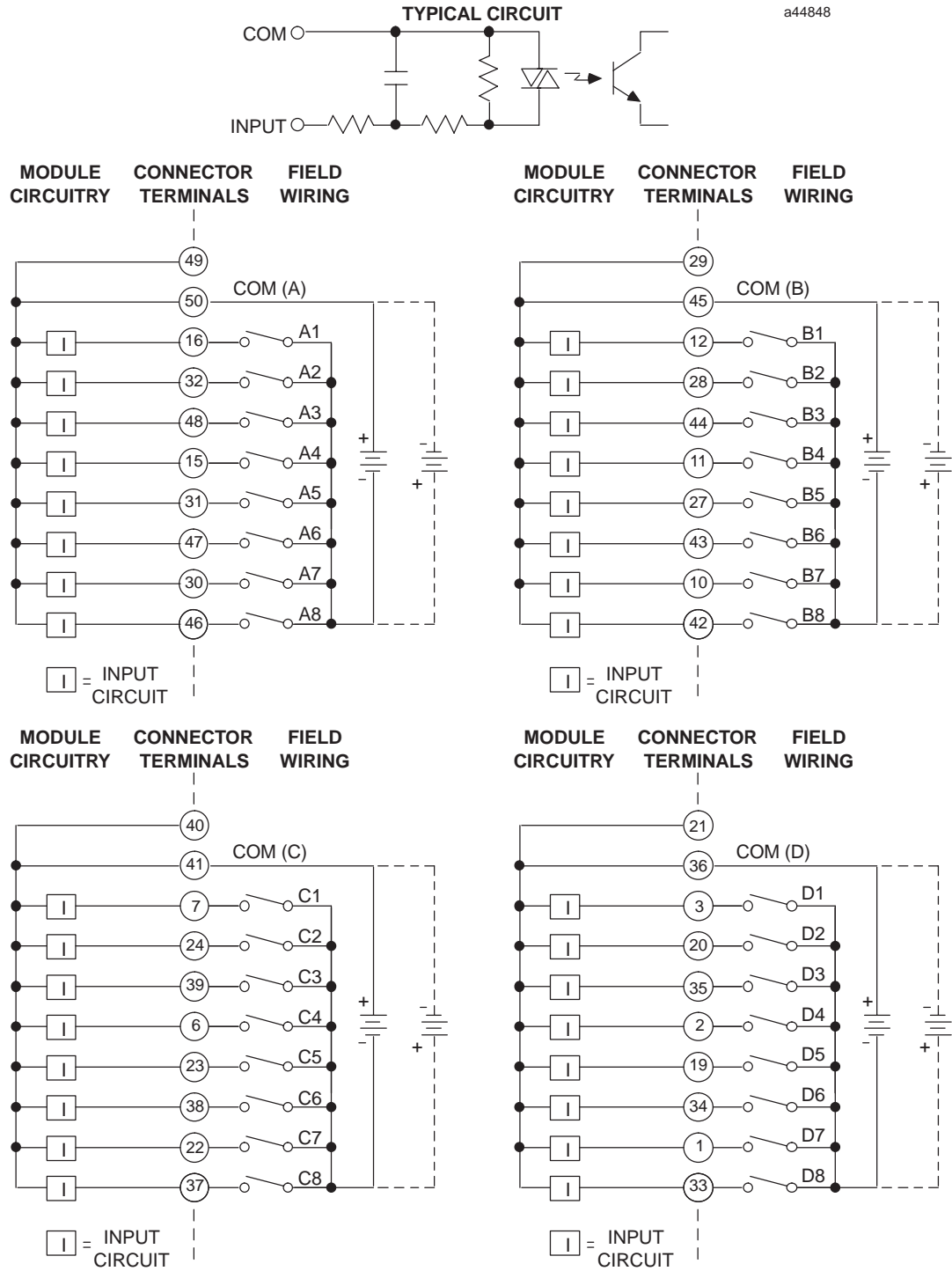
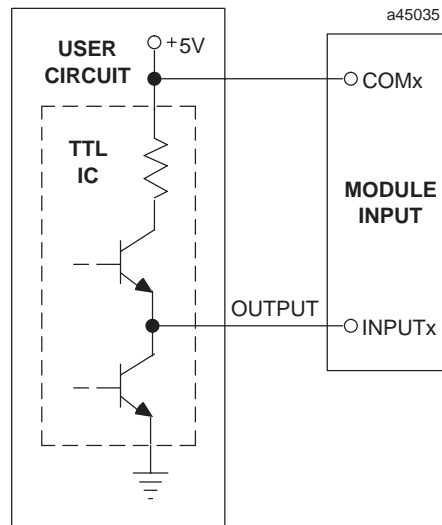

Figure 6-16. Field Wiring - 24 Volt Pos/Neg Logic 32 Point Input Module - IC693MDL653

5/12 VDC (TTL) Positive/Negative Logic, 32 Point Input IC693MDL654

The *5/12 volt DC (TTL) Positive/Negative Logic Input* module for the Series 90-30 Programmable Logic Controller provides 32 discrete TTL voltage threshold input points. The inputs are arranged in four isolated groups of eight (A1 - A8, B1 - B8, C1 - C8, and D1 - D8); each group has its own common. The inputs are positive or negative logic inputs and will operate at levels up to 15V. To be compatible with TTL outputs, the negative logic configuration should be used as shown in the following diagram.



A single, regulated +5V supply (current limited to approximately 150 mA) is available through the I/O connectors on the front of the module. This supply is generated on the module and is isolated from the backplane. Its power input comes from the +5V logic supply on the PLC backplane. By installing jumpers on the appropriate pins on the I/O connector, you can choose to power the inputs from this internal supply instead of powering them with an external user provided supply. If this internal supply is used to power the inputs, additional loading will be placed on the PLC's +5V power supply. Backplane isolation between the field side and logic side is provided by opto-couplers on the module. There are no special fault or alarm diagnostics reported. LED indicators (labeled A1 - A8, B1 - B8, C1 - C8, D1 - D8) at the top of the module provide the ON/OFF status of each input point.

This module is configured as a 32-point input type and uses 32 bits of discrete %I input data. Current into an input point results in a logic 1 in the input status table. This module can be installed in any I/O slot of a 5 or 10-slot baseplate in a Series 90-30 PLC system.

Connections to the input circuits are made from the user's input devices to two male (pin-type) 24-pin connectors (Fujitsu FCN-365P024-AU) mounted on the front of the module. The connector mounted on the right of the module (front view) interfaces with groups A and B. The connector on the left side of the module interfaces with groups C and D.

Wiring from the module's connectors to field devices is made through a cable having a mating female connector on one end and stripped and tinned wires on the other end. You can purchase a pair of pre-wired cables, catalog numbers IC693CBL327 and IC693CBL328 or, if required for your application, build your own cable. Refer to "Building Cables for 24-Pin Connectors" in the IC693CBL327/328 data sheet in Appendix C of this manual for more information.

Table 6-11. Specifications for IC693MDL654

Rated Voltage	5 to 12 volts DC, Positive or Negative Logic
Input Voltage Range	0 to 15 volts DC
Inputs per Module †	32 (four groups of eight inputs each) <i>98.4 feet (30 meters) , maximum cable length</i>
Isolation	1500 volts between field side and logic side 250 volts between groups
Input Current	3.0 mA (typical ON current @ 5 VDC) 8.5 mA (typical ON current @ 12 VDC)
Input Characteristics	
On-state Voltage	4.2 to 15 volts DC
Off-state Voltage	0 to 2.6 volts DC
On-state Current	2.5 mA (minimum)
Off-state Current	1.2 mA (maximum)
On response Time	1 ms maximum
Off response Time	1 ms maximum
Internal Power Consumption	195 mA (maximum) from +5V bus on backplane; (29 mA + 0.5 mA/point ON + 4.7 mA/LED ON) 440 mA (maximum) from +5V bus on backplane <i>(if module isolated +5V supply used to power inputs and all 32 inputs ON)</i> 96 mA (typical) from user input supply @ 5 VDC and all 32 inputs ON) 272 mA (typical) from user input supply @ 12 VDC and all 32 inputs ON)
Isolated +5V Supply	+5 volts DC ±5%
Current limit	150 mA (typical)

† Maximum number of inputs ON is dependent on ambient temperature as shown in the figure below.
Refer to data sheet GFK-0867C, or later revision for product standards and general specifications.

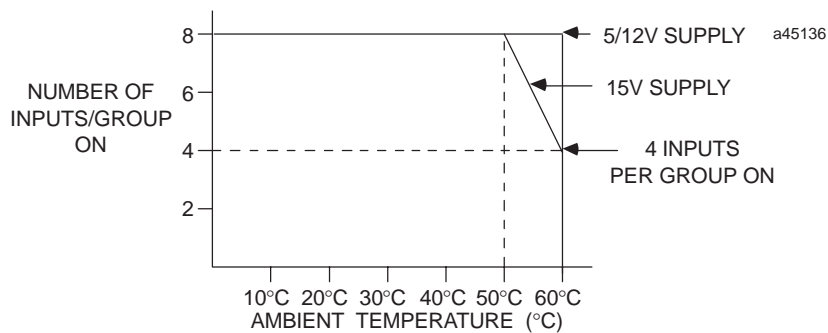

Figure 6-17. Input Points vs. Temperature for IC693MDL654

IC693MDL654 Input Module Field Wiring Information

The following figures provide wiring information for connecting user supplied input devices and power source to the 5/12 volt DC (TTL) pos/neg logic input module.

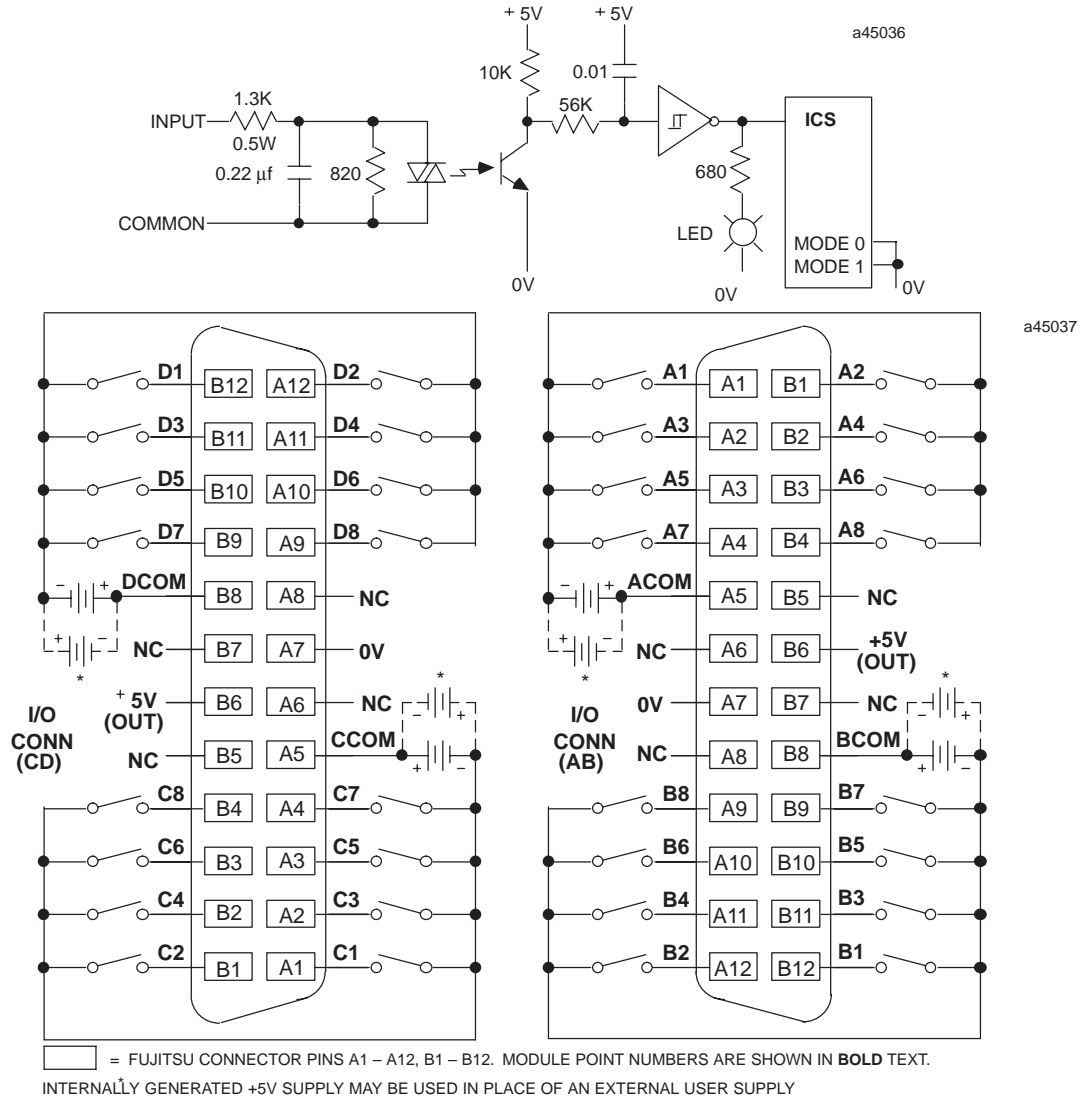

Figure 6-18. Field Wiring 5/12 Volt DC (TTL) Pos/Neg Logic 32-Point Input Module - IC693MDL654

Field Wiring Work Sheet for IC693MDL654

The following table is provided for the convenience of our customers as an aid to wiring 32-point I/O modules that have 24-pin connectors using cable IC693CBL315. It includes all of the required wiring information in one table. This table has the following information:

- *module point number:* A1 - A8, B1 - B8, C1 - C8, D1 - D8, voltage and common points
- *connector pin number:* A1 through A12, and B1 through B12
- *cable pair number:* pair 1 through pair 12
- *wire color code:* base color or base color with tracer color

Columns are also provided for circuit references and customer wire numbers. Please copy and use the work sheets on this and the following page as needed when wiring the 5/12 VDC (TTL) Positive/Negative Logic, 32 Point Input module.

Wiring for Module Groups A and B (connector on right front of module)

Reference	Module Point Number	Connector Pin Number	Cable Pair Number	Wire Color Code	Wire Number
	A1	A1	1	Brown	
	A2	B1	7	Violet	
	A3	A2	1	Brown/Black	
	A4	B2	7	Violet/Black	
	A5	A3	2	Red	
	A6	B3	8	White	
	A7	A4	2	Red/Black	
	A8	B4	8	White/Black	
	A Common	A5	3	Orange	
	N/C	B5	9	Gray	
	N/C	A6	3	Orange/Black	
	+5V OUT	B6	9	Gray/Black	
	0 VOLTS	A7	4	Yellow	
	N/C	B7	10	Pink	
	N/C	A8	4	Yellow/Black	
	B Common	B8	10	Pink/Black	
	B8	A9	5	Dark Green	
	B7	B9	11	Light Blue	
	B6	A10	5	Dark Green/Black	
	B5	B10	11	Light Blue/Black	
	B4	A11	6	Dark Blue	
	B3	B11	12	Light Green	
	B2	A12	6	Dark Blue/Black	
	B1	B12	12	Light Green/Black	

Wiring for Module Groups C and D (connector on left front of module)

Reference	Module Point Number	Connector Pin Number	Cable Pair Number	Wire Color Code	Wire Number
	C1	A1	1	Brown	
	C2	B1	7	Violet	
	C3	A2	1	Brown/Black	
	C4	B2	7	Violet/Black	
	C5	A3	2	Red	
	C6	B3	8	White	
	C7	A4	2	Red/Black	
	C8	B4	8	White/Black	
	C Common	A5	3	Orange	
	N/C	B5	9	Gray	
	N/C	A6	3	Orange/Black	
	+5V OUT	B6	9	Gray/Black	
	0 VOLTS	A7	4	Yellow	
	N/C	B7	10	Pink	
	N/C	A8	4	Yellow/Black	
	D Common	B8	10	Pink/Black	
	D8	A9	5	Dark Green	
	D7	B9	11	Light Blue	
	D6	A10	5	Dark Green/Black	
	D5	B10	11	Light Blue/Black	
	D4	A11	6	Dark Blue	
	D3	B11	12	Light Green	
	D2	A12	6	Dark Blue/Black	
	D1	B12	12	Light Green/Black	

24 VDC Positive/Negative Logic, 32 Point Input IC693MDL655

The *24 volt DC Positive/Negative Logic Input* module for the Series 90-30 Programmable Logic Controller provides 32 discrete input points. The inputs are arranged in four isolated groups of eight (A1 - A8, B1 - B8, C1 - C8, and D1 - D8); each group has its own common. The inputs are positive or negative logic inputs and will operate at levels up to 30V.

Backplane isolation between the field side and logic side is provided by opto-couplers on the module. Isolation is also provided between the four groups of inputs on the module, however each group of eight inputs is referenced to the same user common connection. There are no special fault or alarm diagnostics reported. LED indicators (labeled A1 - A8, B1 - B8, C1 - C8, D1 - D8) at the top of the module provide the ON/OFF status of each input point.

This module is configured as a 32-point input type and uses 32 bits of discrete %I input data. Current into an input point results in a logic 1 in the input status table. Power to operate field devices can be supplied by the user, or from the isolated +24 VDC supply available at the module's I/O connectors. This module can be installed in any I/O slot of a 5 or 10-slot baseplate in a Series 90-30 PLC system.

Connections to the input circuits are made from the user's input devices to two male (pin-type) 24-pin connectors (Fujitsu FCN-365P024-AU) mounted on the front of the module. The connector mounted on the right of the module (front view) interfaces with groups A and B. The connector on the left side of the module interfaces with groups C and D.

Wiring from the module's connectors to field devices is made through a cable having a mating female connector on one end and stripped and tinned wires on the other end. You can purchase a pair of pre-wired cables, catalog numbers IC693CBL327 and IC693CBL328 or, if required for your application, build your own cable. Refer to "Building Cables for 24-Pin Connectors" in the IC693CBL327/328 data sheet in Appendix C of this manual for more information.

Table 6-12. Specifications for IC693MDL655

Rated Voltage	24 volts DC, Positive or Negative Logic
Input Voltage Range	0 to 30 volts DC
Inputs per Module †	32 (four groups of eight inputs each)
Isolation	1500 volts between field side and logic side 250 volts between groups
Input Current	7.0 mA (typical ON current @ 24 VDC)
Input Characteristics	
On-state Voltage	11.5 to 30 volts DC
Off-state Voltage	0 to 5 volts DC
On-state Current	3.2 mA (minimum)
Off-state Current	1.1 mA (maximum)
On response Time	2 ms maximum
Off response Time	2 ms maximum
Internal Power Consumption	195 mA (maximum) from +5V bus on backplane; (29 mA +0.5 mA/point ON +4.7 mA/LED ON) 224 mA (typical) from isolated +24V bus on backplane or from user input supply @ 24 VDC and all 32 inputs ON)

† Maximum number of inputs ON is dependent on ambient temperature as shown in the figure below.

Refer to data sheet GFK-0867F (or later revision) for product standards and general specifications.

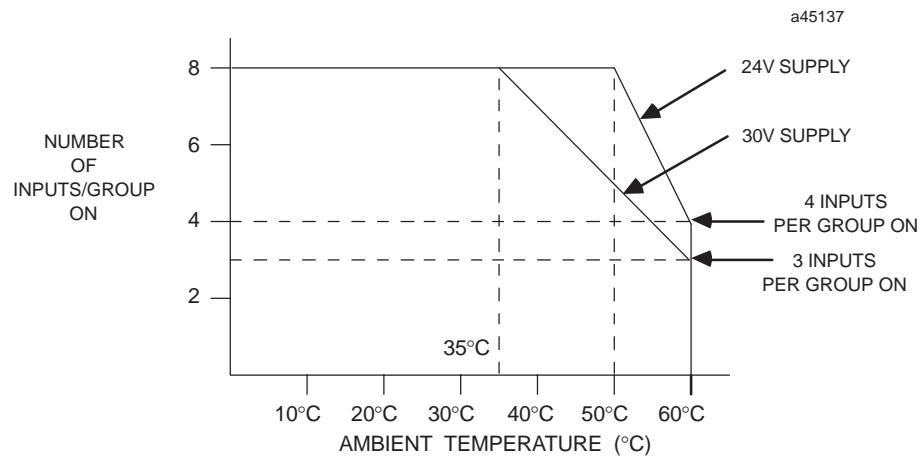
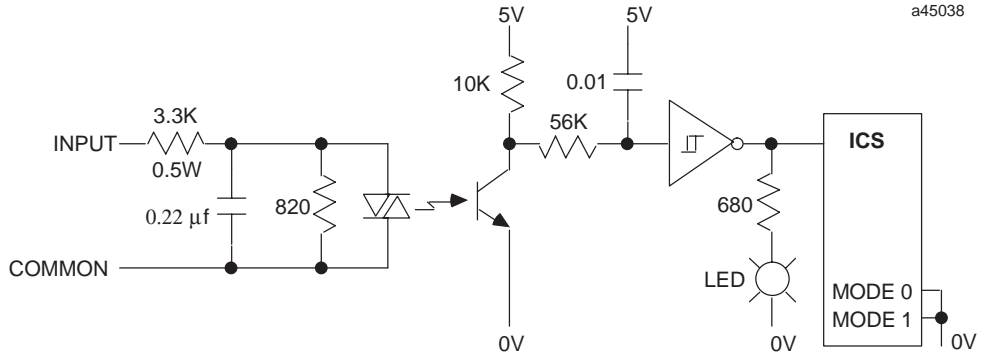

Figure 6-19. Input Points vs. Temperature for IC693MDL655

IC693MDL655 Input Module Field Wiring Information

The following two figures provide wiring information for connecting user supplied input devices and power source to the 24 volt DC (TTL) positive/negative logic input module. The first figure shows a typical input circuit. The second figure shows how field devices are connected to the module.



Module point numbers in the following figure are shown in **bold text**.

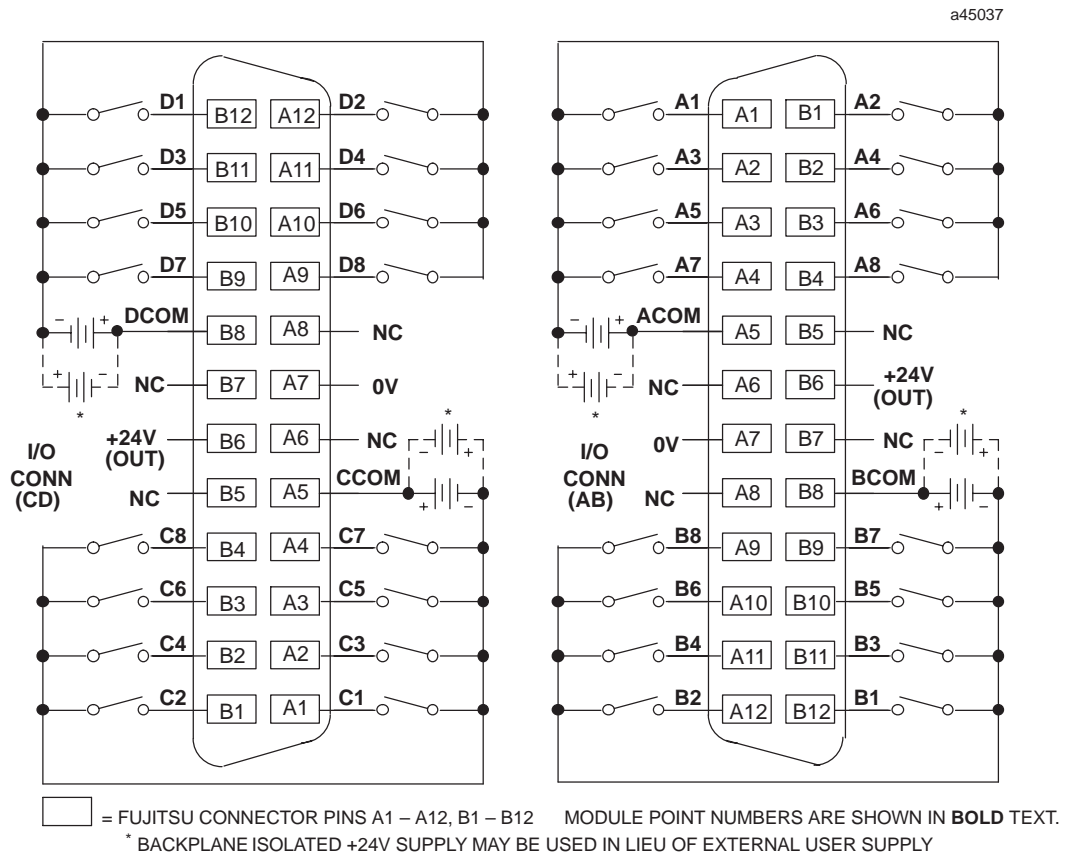

Figure 6-20. Field Wiring 24 Volt DC Positive/Negative Logic 32-Point Input Module - IC693MDL655

Field Wiring Work Sheet for IC693MDL655

The following table is provided for the convenience of our customers as an aid to wiring the 24-pin connectors using cable IC693CBL315. It includes all of the required wiring information in one table. This table has the following information:

- *module point number:* A1 - A8, B1 - B8, C1 - C8, D1 - D8, voltage and common points
- *connector pin number:* A1 through A12, and B1 through B12
- *cable pair number:* pair 1 through pair 12
- *wire color code:* base color or base color with tracer color

Columns are also provided for circuit references and customer wire numbers. Please copy and use the work sheets on this and the following page as needed when wiring the 24 VDC Positive/Negative Logic, 32 Point Input module.

Wiring for Module Groups A and B (connector on right front of module)

Reference	Module Point Number	Connector Pin Number	Cable Pair Number	Wire Color Code	Wire Number
	A1	A1	1	Brown	
	A2	B1	7	Violet	
	A3	A2	1	Brown/Black	
	A4	B2	7	Violet/Black	
	A5	A3	2	Red	
	A6	B3	8	White	
	A7	A4	2	Red/Black	
	A8	B4	8	White/Black	
	A Common	A5	3	Orange	
	N/C	B5	9	Gray	
	N/C	A6	3	Orange/Black	
	+24V OUT	B6	9	Gray/Black	
	0 VOLTS	A7	4	Yellow	
	N/C	B7	10	Pink	
	N/C	A8	4	Yellow/Black	
	B Common	B8	10	Pink/Black	
	B8	A9	5	Dark Green	
	B7	B9	11	Light Blue	
	B6	A10	5	Dark Green/Black	
	B5	B10	11	Light Blue/Black	
	B4	A11	6	Dark Blue	
	B3	B11	12	Light Green	
	B2	A12	6	Dark Blue/Black	
	B1	B12	12	Light Green/Black	

Wiring for Module Groups C and D (connector on left front of module)

Reference	Module Point Number	Connector Pin Number	Cable Pair Number	Wire Color Code	Wire Number
	C1	A1	1	Brown	
	C2	B1	7	Violet	
	C3	A2	1	Brown/Black	
	C4	B2	7	Violet/Black	
	C5	A3	2	Red	
	C6	B3	8	White	
	C7	A4	2	Red/Black	
	C8	B4	8	White/Black	
	C Common	A5	3	Orange	
	N/C	B5	9	Gray	
	N/C	A6	3	Orange/Black	
	+24V OUT	B6	9	Gray/Black	
	0 VOLTS	A7	4	Yellow	
	N/C	B7	10	Pink	
	N/C	A8	4	Yellow/Black	
	D Common	B8	10	Pink/Black	
	D8	A9	5	Dark Green	
	D7	B9	11	Light Blue	
	D6	A10	5	Dark Green/Black	
	D5	B10	11	Light Blue/Black	
	D4	A11	6	Dark Blue	
	D3	B11	12	Light Green	
	D2	A12	6	Dark Blue/Black	
	D1	B12	12	Light Green/Black	

Chapter 7

Discrete Output Modules

efesotomasyon.com

IC693DVM300 5VDC Input/24VDC Output Digital Valve Driver Module

This 4-channel digital valve driver module is capable of driving loads of up to 1.6 Amps at 24 VDC. Although it mounts in a standard Series 90-30 PLC slot, it **does not connect to the PLC backplane**. Its control power and output power are supplied externally. (The GE Fanuc IC690PWR124 stand-alone power supply would be a suitable choice for the 24VDC output power.) This module is designed for TTL-level (5 Vdc) inputs.

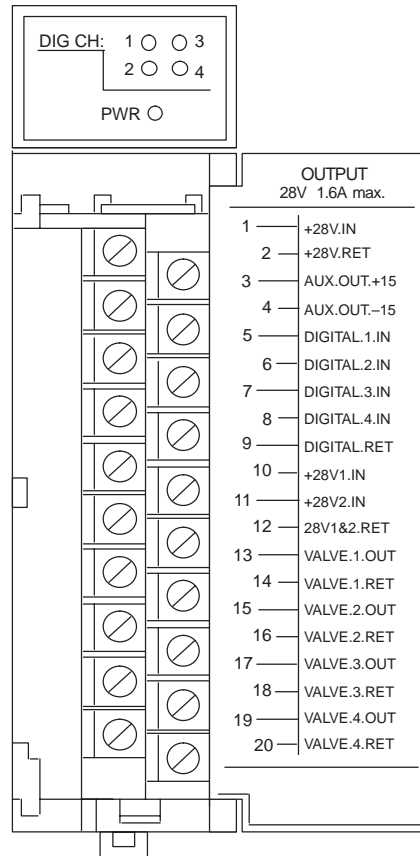

Figure 7-1. IC693DVM300 Digital Valve Driver Module

Indicator LEDs

- **DIG CH: 1 - 4:** These light when their corresponding input is at a Logic 1 level.
- **PWR:** Lights to indicate the presence of +26 VDC (nominal) input power on terminals 1 and 2.

DVM Specifications

Table 7-1. IC693DVM300 Specifications

OUTPUT CHARACTERISTICS	
Outputs (Channels) per Module	4
Isolation	2500 Vrms (optical isolation)
Nominal Output Voltage	24 Vdc
Power Supply for Output Channels	26 Vdc nominal, 21 Vdc minimum, 35 Vdc maximum
Output Current	1.6 Amps maximum per channel 6.4 Amps maximum total per module
Output Voltage Drop (fully loaded)	0.32 Vdc
Off state leakage current	26 µA at 26 Vdc operating voltage
Turn-on response time	< 1 µS with resistive load
Turn-off response time	< 1 µS with resistive load
Output protection (per channel)	Reversed-biased zener diode for free-wheeling inductive current. Also 36 Volt transorb for ESD and surge protection.
INPUT CHARACTERISTICS	
Input Voltage	5 VDC (TTL) nominal, 12Vdc Maximum
Logic 1 Level	Logic 1: V > 3.5 Vdc Logic 0: V < 0.7 Vdc
Input Current	3.8 mA nominal
Input protection	13.3 Volt transorb
AUXILIARY POWER SUPPLY OUTPUTS	
Voltage and Current	+15 VDC @ 0.3A and -15 VDC @ 0.2A
Isolation	Not isolated
MODULE POWER REQUIREMENTS	
Power Consumption (Does not consume any power from PLC backplane.)	5.6 Watts (with all outputs on) from external supply connected to terminals 1 and 2 (does not include power consumed by outputs)
Input Voltage	+26 VDC nominal, 35 VDC maximum continuous

Fuses

- Quantity 1 – Module control power. 1 Amp. Buss GDB-1A.
- Quantity 4 – One for each output. 2 Amps. Littlefuse 239002.

DVM Connections

Table 7-2. IC693DVM300 Connections

Pin No.	Signal Name	Connection Description
1	+28V.IN	Module Control Power + input terminal (common on pin 2). Supplies power to module's signal-level circuits and auxiliary +15 and -15 Volt power supplies (pins 2, 3, and 4). Requires external 26 VDC (nominal) power supply
2	+28V.RET	Common terminal for Module Control Power (pin 1).
3	AUX.OUT.+15	+ 15 Vdc @ 0.3A Auxiliary power output for external circuits. Not isolated. Developed from input power on pins 1 and 2.
4	AUT.XOUT.-15	- 15 Vdc @ 0.2A Auxiliary power output for external circuits. Not isolated. Developed from input power on pins 1 and 2.
5	DIGITAL.1.IN	Channel 1 TTL input connection (common on pin 9)
6	DIGITAL.2.IN	Channel 2 TTL input connection (common on pin 9)
7	DIGITAL.3.IN	Channel 3 TTL input connection (common on pin 9)
8	DIGITAL.4.IN	Channel 4 TTL input connection (common on pin 9)
9	DIGITAL.RET	Common connection for Digital Input Channels 1 – 4 (pins 5 – 8)
10	+28V1.IN	Power Supply connection for Output Channels 1 and 2 (common on pin 12). Required external 26 VDC (nominal) power supply.
11	+28V2.IN	Power Supply connection for Output Channels 3 and 4 (common on pin 12). Required external 26 VDC (nominal) power supply.
12	28V1&2.RET	Common connection for both Output Channel Power Supply inputs (pins 10 and 11)
13	VALVE1.OUT	Channel 1 Output connection (return on pin 14)
14	VALVE1.RET	Return connection for Channel 1 Output (pin 13)
15	VALVE2.OUT	Channel 2 Output connection (return on pin 16)
16	VALVE2.RET	Return connection for Channel 2 Output (pin 15)
17	VALVE3.OUT	Channel 3 Output connection (return on pin 18)
18	VALVE3.RET	Return connection for Channel 3 Output (pin 17)
19	VALVE4.OUT	Channel 4 Output connection (return on pin 20)
20	VALVE4.RET	Return connection for Channel 4 Output (pin 19)

120 Volt AC Output - 0.5 Amp, 12 Point IC693MDL310

The *120 volt, 0.5 Amp AC Output* module provides 12 output points in two isolated groups with six points in each group. Each group has a separate common associated with it (the two commons are not tied together inside the module). This allows each group to be used on different phases of the AC supply, or powered from the same supply. Each group is protected with a 3 amp fuse, and an RC snubber is provided for each output to protect against transient electrical noise on the power line. This module provides a high-degree of inrush current (10x the rated current) which makes the outputs suitable for controlling a wide range of inductive and incandescent loads. AC Power to operate loads connected to outputs must be user supplied. This module requires an AC power source.

LED indicators which provide the ON/OFF status of each point are at the top of the module. The LEDs are arranged in two horizontal rows with eight green LEDs in each row and a red LED centered between and to the right of the two rows. This module uses the first six LEDs, labeled A1 through 6 in the top row and the first six LEDs, labeled B1 through 6, in the bottom row, for output status. The red LED (labeled F) functions as a blown fuse indicator that turns ON if any of the fuses should blow. An insert goes between the inside and outside surface of the hinged door. The surface towards the inside of the module (when the hinged door is closed) has circuit wiring information, and circuit identification information can be recorded on the outside surface. The outside left edge of the insert is color-coded red to indicate a high-voltage module. This module can be installed in any I/O slot of a 5 or 10-slot baseplate in a Series 90-30 PLC system.

Although this module is configured as a 16 point output, only outputs 1 through 6 and 9 through 14 are available to be referenced in your program. For example, if the starting reference is Q0017, then valid references are Q17 through Q22 and Q25 through Q30.

Table 7-3. Specifications for IC693MDL310

Rated Voltage	120 volts AC
Output Voltage Range	85 to 132 volts AC, 50/60 Hz
Outputs per Module	12 (two groups of six outputs each)
Isolation	1500 volts between field side and logic side 500 volts between each group
Output Current †	0.5 amp maximum per point 1 amp maximum per group at 60°C (140°F) 2 amps maximum per group at 50°C (122°F)
Output Characteristics	
Inrush Current	5 amps maximum for one cycle
Minimum Load Current	50 mA
Output Voltage Drop	1.5 volts maximum
Output Leakage Current	3 mA maximum at 120 volts AC
On Response Time	1 ms maximum
Off Response Time	1/2 cycle maximum
Power Consumption	210 mA (all outputs on) from 5 volt bus on backplane

† Maximum load current is dependent upon ambient temperature as shown in graph on following page.

Refer to Appendix B for product standards and general specifications.

IC693MDL310 Output Module Field Wiring Information

The following figure provides wiring information for connecting user supplied input devices and power source to the 120 volt AC output module.

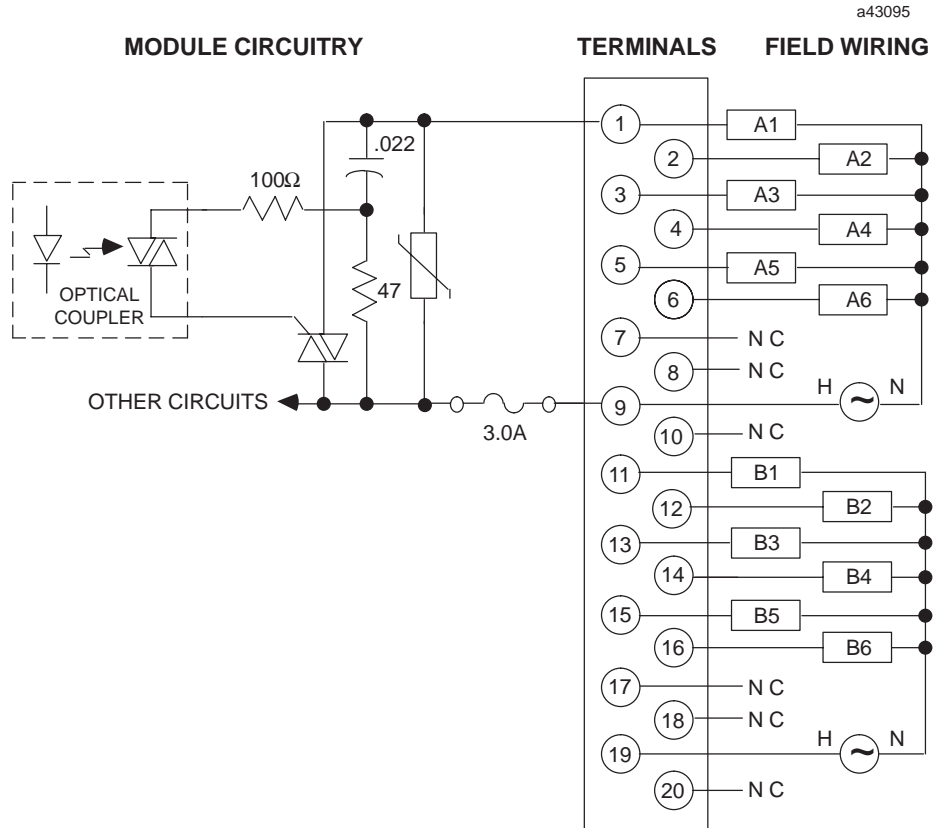

Figure 7-2. IC693MDL310 Output Module Field Wiring

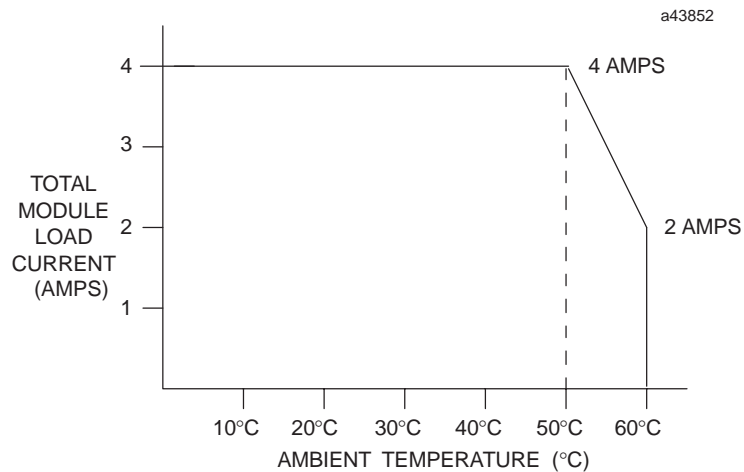

Figure 7-3. Input Points vs. Temperature for IC693MDL310

120/240 Volt AC Output - 2 Amp, 8 Point IC693MDL330

This 2 amp AC output module has a catalog number with a D or later suffix (i.e., IC693MDL330D); previous versions (modules with a C or earlier suffix) were rated at 1 amp. The **120/240 volt, 2 Amp AC Output** module for the Series 90-30 Programmable Logic Controller provides 8 output points in two isolated groups with four points in each group. Each group has a separate common associated with it. The two commons are not tied together inside the module. This allows each group to be used on different phases of the AC supply, or they can be powered from the same supply. Each group is protected with a 5 amp fuse for each common, and an RC snubber is provided for each output to protect against transient electrical noise on the power line. This module provides a high-degree of inrush current (10x the rated current) which makes the outputs suitable for controlling a wide range of inductive and incandescent loads. AC Power (DC power cannot be used) to operate loads connected to outputs must be supplied by the user.

LED indicators which provide the ON/OFF status of each point are located at the top of the module. There are two horizontal rows with eight green LEDs in each row and a red LED centered between and to the right of the two rows. This module uses the upper eight LEDs, labeled A1 through 8 for output status. The red “F” LED is a blown fuse indicator that turns ON if any of the fuses should blow. An insert goes between the inside and outside surface of the hinged door. The surface towards the inside of the module (when the hinged door is closed) has circuit wiring information, and circuit identification information can be recorded on the outside surface. The outside left edge of the insert is color-coded red to indicate a high-voltage module. This module can be installed in any I/O slot of a 5 or 10-slot baseplate in a Series 90-30 PLC system.

Table 7-4. Specifications for IC693MDL330

Rated Voltage	120/240 volts AC
Output Voltage Range	85 to 264 volts AC, 50/60 Hz
Outputs per Module	8 (two groups of four outputs each)
Isolation	1500 volts between field side and logic side 500 volts between each group
Output Current †	2 amp maximum per point 4 amps maximum per group at 40° C (104°F)
Output Characteristics	
Inrush Current	20 amps maximum for one cycle
Minimum Load Current	100 mA
Output Voltage Drop	1.5 volts maximum
Output Leakage Current	3 mA maximum at 120 volts AC 6 mA maximum at 240 volts AC
On Response Time	1 ms maximum
Off Response Time	1/2 cycle maximum
Power Consumption	160 mA (all outputs on) from 5 volt bus on backplane

† Maximum load current is dependent upon ambient temperature as shown in graph on following page.
Refer to Appendix B for product standards and general specifications.

IC693MDL330 Output Module Field Wiring Information

The following figure provides wiring information for connecting user supplied input devices and power source to the 120/240 volt AC output, 2 Amp module.

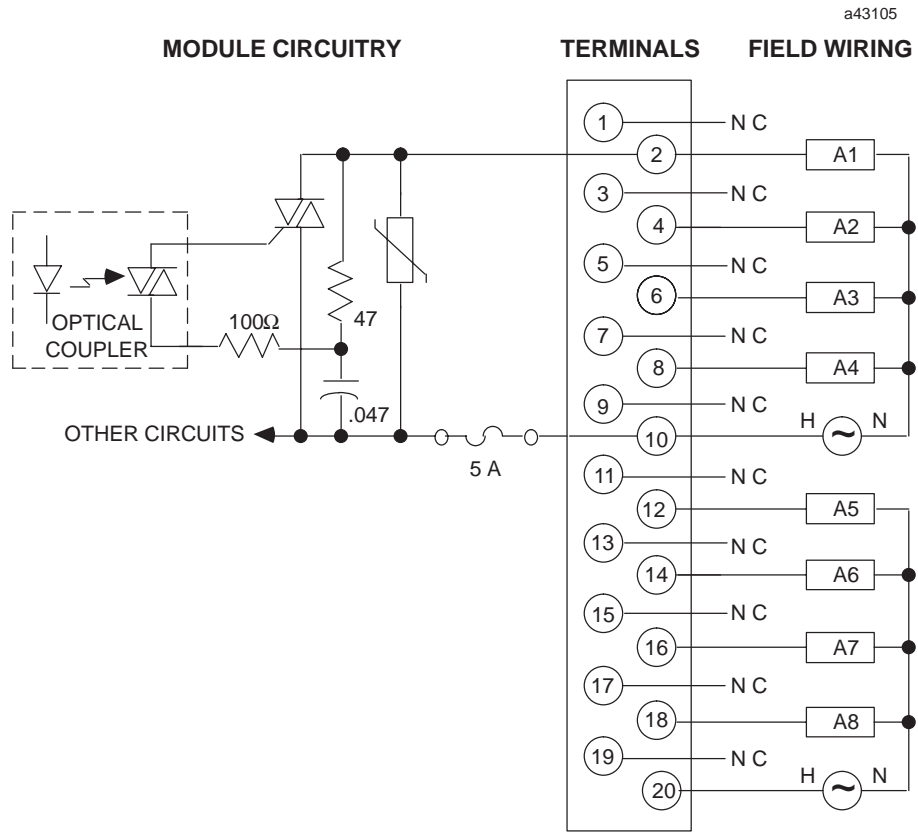

Figure 7-4. Field Wiring - 120/240 Volt AC Output, 2 Amp Module - IC693MDL330

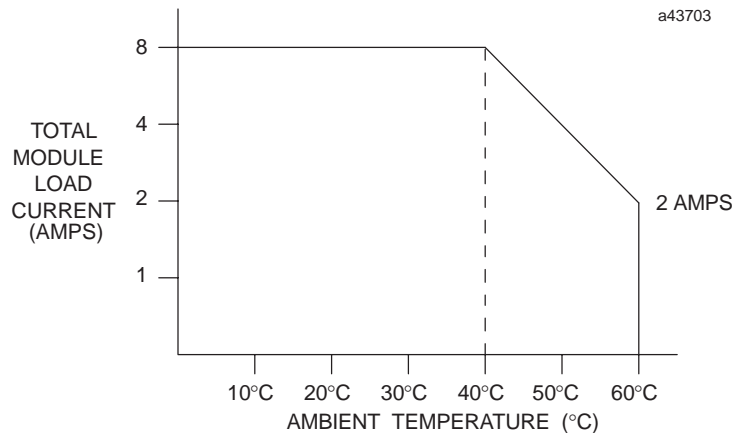

Figure 7-5. Input Points vs. Temperature for IC693MDL330

120 Volt AC Output - 0.5 Amp, 16 Point IC693MDL340

The *120 volt, 0.5 Amp AC Output* module provides 16 output points in two isolated groups with eight points in each group. Each group has a separate common associated with it (the two commons are not tied together inside the module). This allows each group to be used on different phases of the AC supply, or they can be powered from the same supply. Each group is protected with a 3 amp fuse, and an RC snubber is provided for each output to protect against transient electrical noise on the power line. This module provides a high-degree of inrush current which makes the outputs suitable for controlling a wide range of inductive and incandescent loads. AC Power to operate loads connected to outputs must be supplied by the user. This module requires an AC power source.

LED indicators which provide the ON/OFF status of each point are located at the top of the module. There are two horizontal rows with eight green LEDs in each row and a red LED centered between and to the right of the two rows. This module uses the two rows of green LEDs, labeled A1 through 8 and B1 through 8 for output status. The red LED (labeled F) is a blown fuse indicator that turns ON if either of the fuses should blow. A load must be connected to the blown fuse for the indicator to light. An insert goes between the inside and outside surface of the hinged door. The surface towards the inside of the module (when the hinged door is closed) has circuit wiring information, and circuit identification information can be recorded on the outside surface. The outside left edge of the insert is color-coded red to indicate a high-voltage module. This module can be installed in any I/O slot of a 5 or 10-slot baseplate in a Series 90-30 PLC system.

Table 7-5. Specifications for IC693MDL340

Rated Voltage	120 volts AC
Output Voltage Range	85 to 132 volts AC, 50/60 Hz
Outputs per Module	16 (two groups of eight outputs each)
Isolation	1500 volts between field side and logic side 500 volts between each group
Output Current	0.5 amp maximum per point 3 amps maximum per group
Output Characteristics	
Inrush Current	20 amps maximum for one cycle
Minimum Load Current	50 mA
Output Voltage Drop	1.5 volts maximum
Output Leakage Current	2 mA maximum at 120 volts AC
On Response Time	1 ms maximum
Off Response Time	1/2 cycle maximum
Power Consumption	315 mA (all outputs ON) from 5 volt bus on backplane

Refer to Appendix B for product standards and general specifications.

IC693MDL340 Output Module Field Wiring Information

The following figure provides wiring information for connecting user supplied input devices and power source to the 120 volt AC output module.

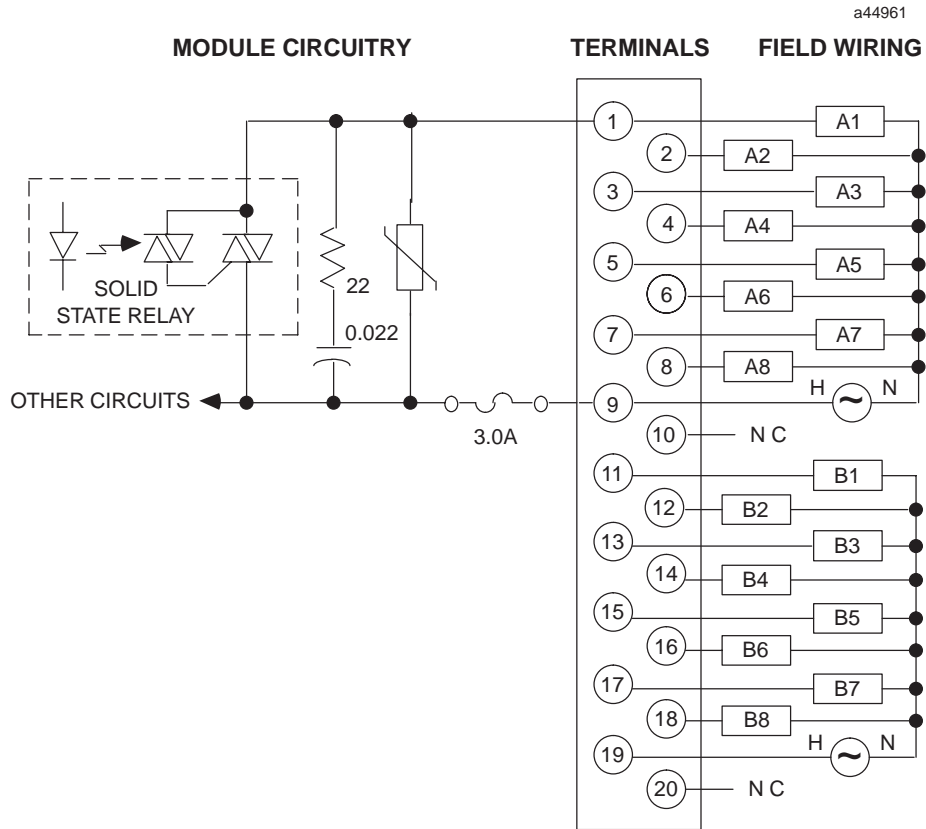

Figure 7-6. IC693MDL340 Output Module Field Wiring

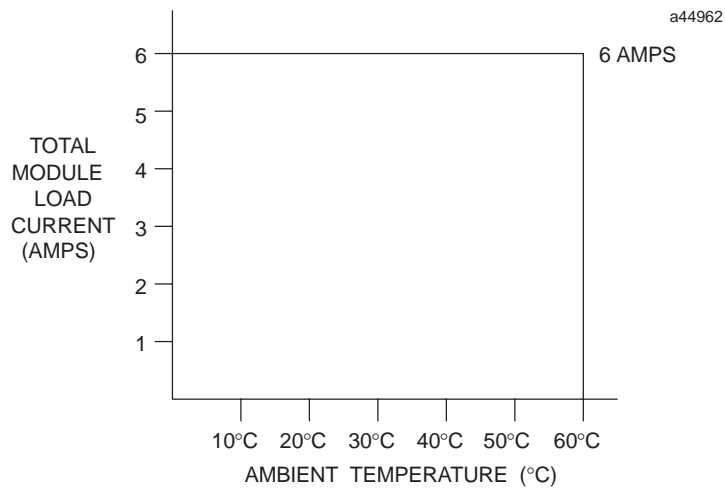

Figure 7-7. Load Current vs. Temperature for IC693MDL340

120/240 Volt AC Isolated Output - 2 Amp, 5 Point IC693MDL390

The *120/240 volt, 2 Amp Isolated AC Output* module for the Series 90-30 Programmable Logic Controller provides 5 isolated output points with each point having a separate common. Each output circuit is isolated from the others relative to the AC power source; commons are not tied together inside the module. This allows each output circuit to be used on different phases of the AC supply, or they can be powered from the same supply. Outputs are individually fused with a 3 amp fuse and an RC snubber is provided for each output to protect against transient electrical noise on the power line. This module provides a high-degree of inrush current (greater than 10x the rated current) making the outputs suitable for controlling a wide range of inductive and incandescent loads. AC Power to operate the loads connected to the outputs must be supplied by the user. ***This module requires an AC power source, it can not be used with a DC power source.***

LED indicators which provide the ON/OFF status of each point are located at the top of the module. These LEDs are arranged in two horizontal rows with eight green LEDs in each row and a red LED centered between and to the right of the two rows. This module uses the first five LEDs, labeled A1 through 5 in the top row for output status. The red “F” LED is a blown fuse indicator that turns ON if any fuse should blow. An insert goes between the inside and outside surface of the hinged door. The surface towards the inside of the module (when the hinged door is closed) has circuit wiring information, and circuit identification information can be recorded on the outside surface. The outside left edge of the insert is color-coded red to indicate a high-voltage module. This module can be installed in any I/O slot in a Series 90-30 PLC system, ***and it should be configured as an 8 point output with programs referencing the five least significant bits.***

Table 7-6. Specifications for IC693MDL390

Rated Voltage	120/240 volts AC
Output Voltage Range	85 to 264 volts AC, 50/60 Hz
Outputs per Module	5 (each output isolated from the others)
Isolation	1500 volts between field side and logic side 500 volts between each output
Output Current †	2 amps maximum per point 5 amps maximum per module at 45° C (113° F) 2 amps maximum per module at 60° C (140° F)
Output Characteristics	
Inrush Current	25 amps maximum for one cycle
Minimum Load Current	100 mA
Output Voltage Drop	1.5 volts maximum
Output Leakage Current	3 mA maximum at 120 volts AC 6 mA maximum at 240 volts AC
On Response Time	1 ms maximum
Off Response Time	1/2 cycle maximum
Power Consumption	110 mA (all outputs on) from 5 volt bus on backplane

† Maximum load current is dependent upon ambient temperature as shown in graph on following page.

Refer to Appendix B for product standards and general specifications.

IC693MDL390 Output Module Field Wiring Information

The following figure provides wiring information for connecting user supplied input devices and power source to the 120/240 volt isolated AC output module.

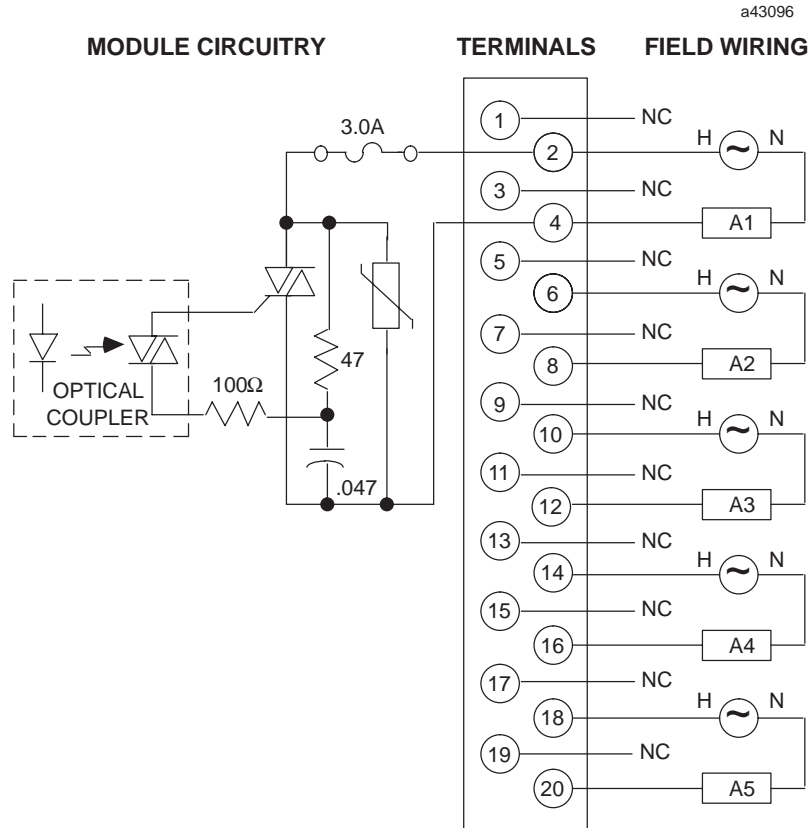

Figure 7-8. IC693MDL390 Output Module Field Wiring

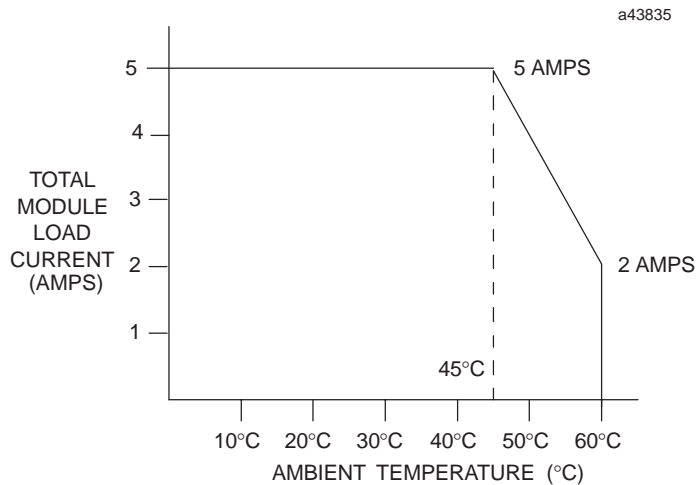

Figure 7-9. Load Current vs. Temperature for IC693MDL390

12/24 Volt DC Positive Logic Output - 2 Amp, 8 Point IC693MDL730

The *12/24 volt DC Positive Logic 2 Amp Output* module for the Series 90-30 Programmable Logic Controller provides 8 output points in one group with a common power input terminal. This output module is designed to have positive logic characteristics in that it sources current to the loads from the user common or positive power bus. The output device is connected between the negative power bus and the module output. The output characteristics are compatible with a wide range of user-supplied load devices, such as: motor starters, solenoids, and indicators. Power to operate the field devices must come from an external power supply supplied by the user.

LED indicators which provide the ON/OFF status of each point are located at the top of the module. This LED block has two horizontal rows with eight green LEDs in each row. This module uses the top row labeled A1 through 8 (points 1 through 8). A red LED (labeled "F") on the right and centered between the two rows of green LEDs functions as a blown fuse indicator; it turns ON when any fuse is blown. The module has two 5 Amp fuses with each fuse protecting four outputs; the first fuse protects A1 - A4, the second fuse protects A5 - A8. The fuses are electrically connected to the same common. An insert goes between the inside and outside surface of the hinged door. The surface towards the inside of the module (when the hinged door is closed) has circuit wiring information, and circuit identification information can be recorded on the outside surface. The outside left edge of the insert is color-coded blue to indicate a low-voltage module.

This module can be installed in any I/O slot of a 5 or 10-slot baseplate in a Series 90-30 PLC system.

Table 7-7. Specifications for IC693MDL730

Rated Voltage	12/24 volts DC
Output Voltage Range	12 to 24 volts DC (+20%, -15%)
Outputs per Module	8 (one group of eight outputs)
Isolation	1500 volts between field side and logic side
Output Current †	2 amps maximum per point 2 amps maximum per fuse at 60°C (140°F) 4 amps maximum per fuse at 50°C (122°F)
Output Characteristics	
Inrush Current	9.4 amps for 10 ms
Output Voltage Drop	1.2 volts maximum
Off-state Leakage	1 mA maximum
On Response Time	2 ms maximum
Off Response Time	2 ms maximum
Power Consumption	55 mA (all outputs on) from 5 volt bus on backplane

† Maximum load current is dependent upon ambient temperature as shown in graph on next page.

Refer to Appendix B for product standards and general specifications.

IC693MDL730 Output Module Field Wiring Information

The following figure provides wiring information for connecting user supplied load devices and power source to the 12/24 volt DC positive logic 2 amp output module.

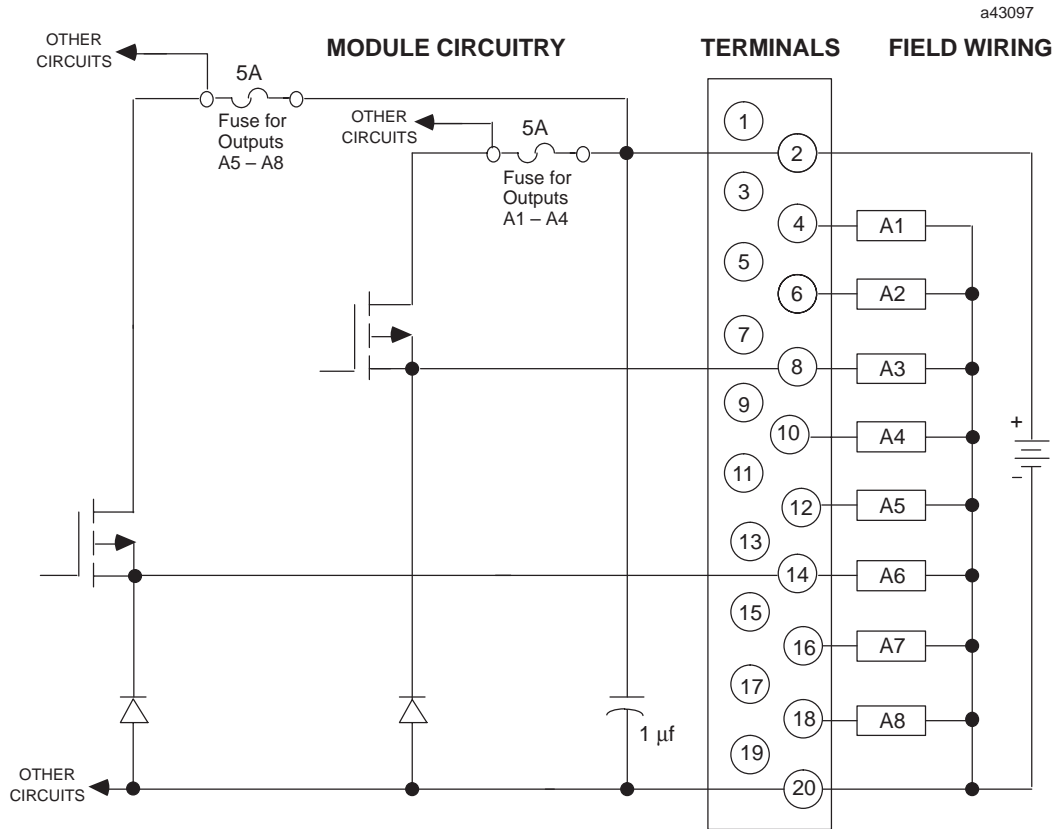

Figure 7-10. IC693MDL730 Output Module Field Wiring

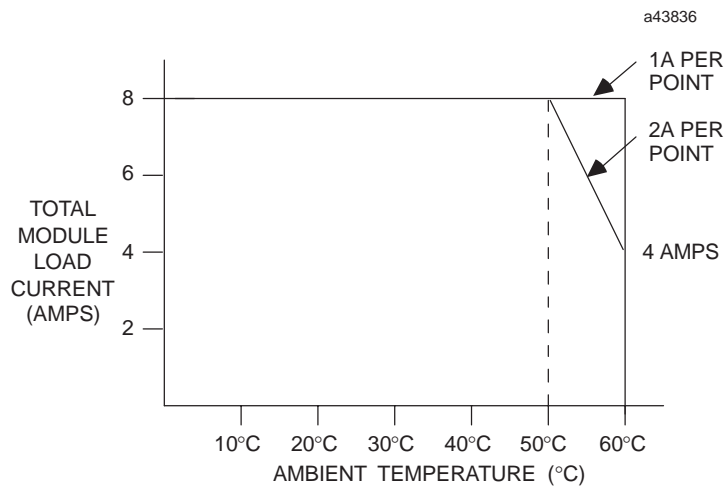

Figure 7-11. Load Current vs. Temperature for IC693MDL730

Installing and Removing IC693MDL730 Terminal Boards with Holding Screws

Discrete output modules IC693MDL730F (and later versions) and IC693MDL731F (and later versions) have a special terminal board that is equipped with holding screws, as shown in the figure below. These screws prevent the terminal board-to-module connections from deteriorating in applications where the PLC is subjected to severe vibration .

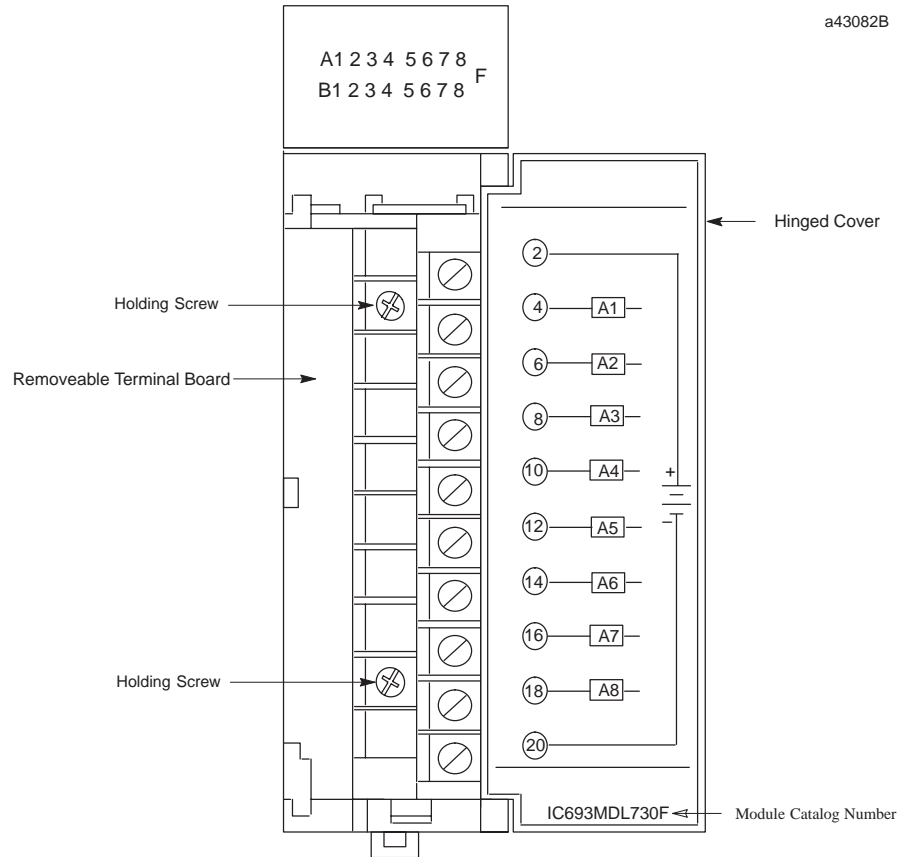

Figure 7-12. Terminal Board with Holding Screws

- Removing:** To Remove these terminal boards, first loosen the two holding screws on the front of the terminal board, then follow the standard removal instructions in the section “Removing an I/O Module’s Terminal Board.” The holding screws are held captive in the terminal board and do not have to be completely removed.
- Installing:** To install these terminal boards, follow the standard installation instructions in the section “Installing an I/O Module’s Terminal Board,” then tighten the two holding screws to 8 to 10 inch pounds (1 Newton-meter) of torque.

12/24 Volt DC Negative Logic Output - 2 Amp, 8 Point IC693MDL731

The *12/24 volt DC Negative Logic 2 Amp Output* module for the Series 90-30 Programmable Logic Controller provides 8 output points in one group with a common power output terminal. This output module is designed to have negative logic characteristics in that it sinks current from the loads to the user common or negative power bus. The output device is connected between the positive power bus and the module output. The output characteristics are compatible with a wide range of user-supplied load devices, such as: motor starters, solenoids, and indicators. Power to operate the field devices must be supplied by the user.

LED indicators which provide the ON/OFF status of each point are located at the top of the module. This LED block has two horizontal rows with eight green LEDs in each row. This module uses only the top row labeled A1 through 8 (points 1 through 8). A red LED (labeled "F") on the right and centered between the two rows of green LEDs functions as a blown fuse indicator; it turns ON when any fuse is blown. The module has two 5 amp fuses with each fuse protecting four outputs; the first fuse protects A1 - A4, the second fuse protects A5 - A8. The fuses are electrically connected to the same common. An insert goes between the inside and outside surface of the hinged door. The surface towards the inside of the module (when the hinged door is closed) has circuit wiring information, and circuit identification information can be recorded on the outside surface. The outside left edge of the insert is color-coded blue to indicate a low-voltage module. This module can be installed in any I/O slot of a 5 or 10-slot baseplate in a Series 90-30 PLC system.

Table 7-8. Specifications for IC693MDL731

Rated Voltage	12/24 volts DC
Output Voltage Range	12 to 24 volts DC (+20%, -15%)
Outputs per Module	8 (one group of eight outputs)
Isolation	1500 volts between field side and logic side
Output Current †	2 amps maximum per point 4 amps maximum per fuse at 50° C (122° F) 2 amps maximum per fuse at 60° C (140° F)
Output Characteristics	
Output Voltage Drop	0.75 volts maximum
Off-state Leakage	1 mA maximum
On Response Time	2 ms maximum
Off Response Time	2 ms maximum
Power Consumption	55 mA (all outputs on) from 5 volt bus on backplane

† Maximum load current is dependent upon ambient temperature as shown in figure 2-27.

Refer to Appendix B for product standards and general specifications.

IC693MDL731 Output Module Field Wiring Information

The following figure provides wiring information for connecting user supplied load devices and power source to the 12/24 volt DC negative logic 2 amp output module.

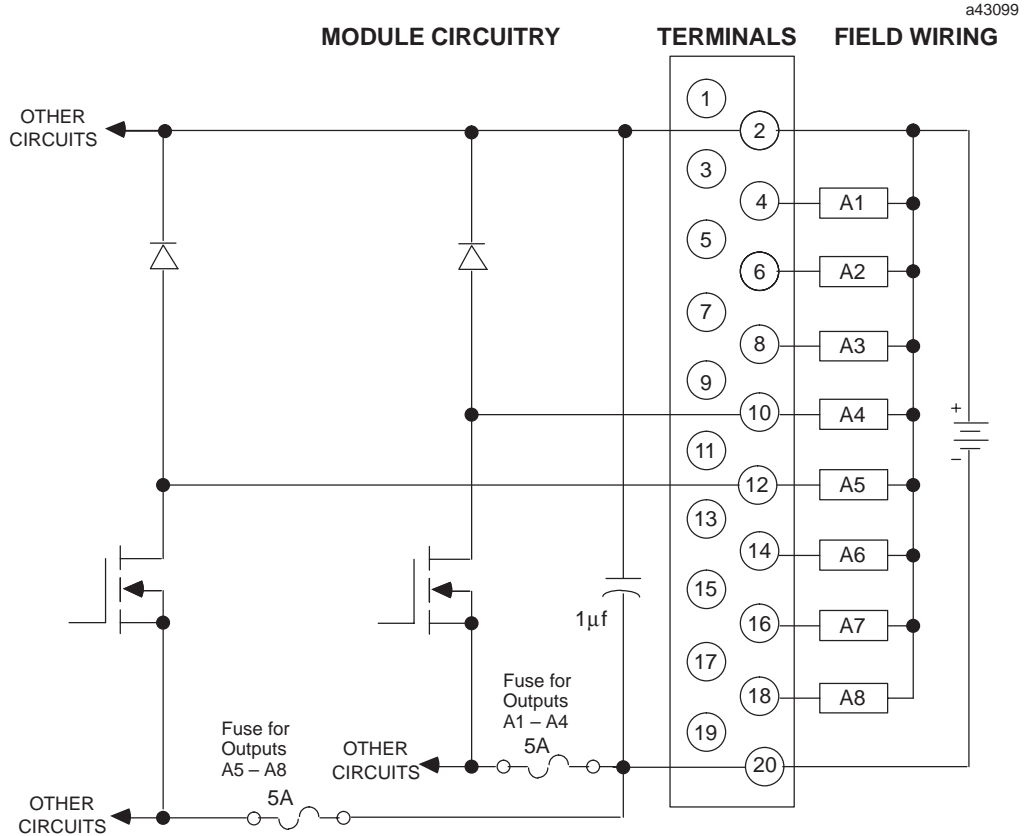

Figure 7-13. IC693MDL731 Output Module Field Wiring

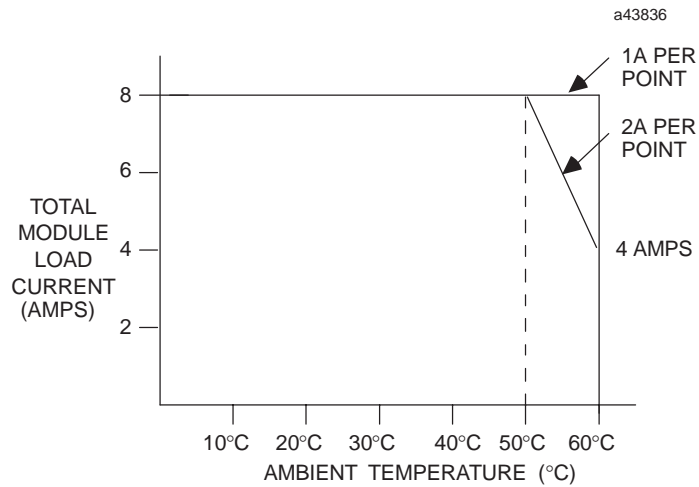

Figure 7-14. Load Current vs. Temperature for IC693MDL731

Installing and Removing IC693MDL731 Terminal Boards with Holding Screws

Discrete output modules IC693MDL730F (and later) and IC693MDL731F (and later) have a special terminal board that is equipped with holding screws, as shown in the figure below. These screws prevent the terminal board-to-module connections from deteriorating in applications where the PLC is subjected to severe vibration .

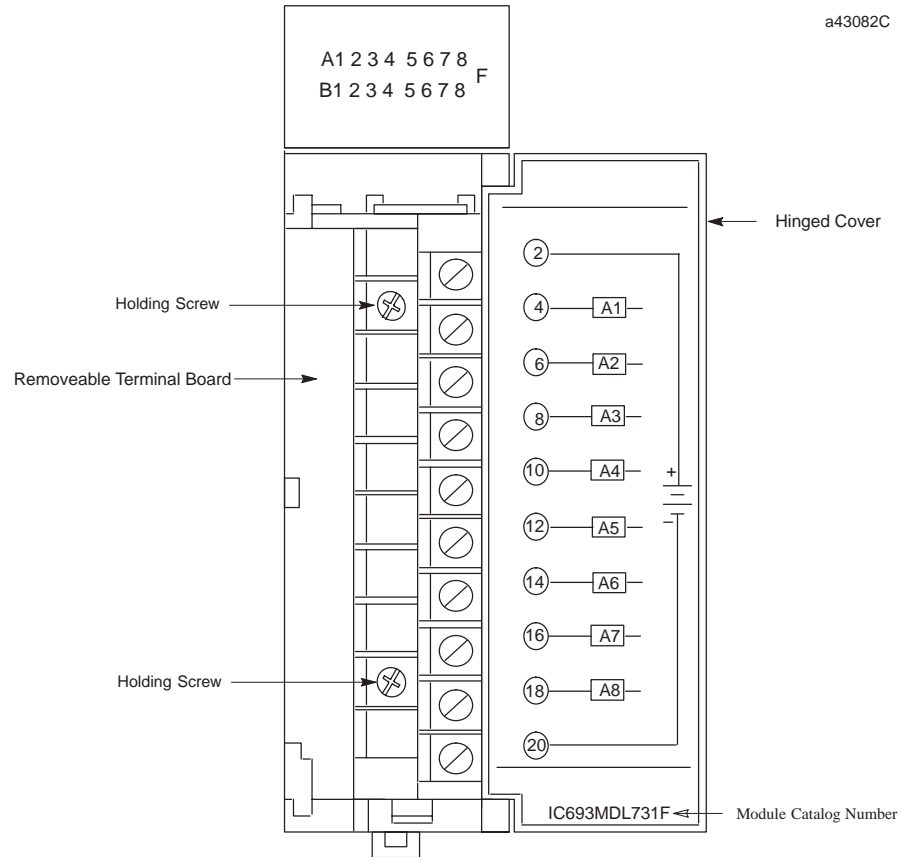

Figure 7-15. Terminal Board with Holding Screws

- Removing:** To Remove these terminal boards, first loosen the two holding screws on the front of the terminal board, then follow the standard removal instructions in Chapter 2. The holding screws are held captive in the terminal board and do not have to be completely removed.
- Installing:** To install these terminal boards, follow the standard installation instructions in Chapter 2, then tighten the two holding screws to 8 to 10 inch pounds (1 Newton-meter) of torque.

12/24 Volt DC Positive Logic Output - 0.5 Amp, 8 Point IC693MDL732

This *12/24 volt DC Positive Logic 0.5 Amp Output* module for the Series 90-30 Programmable Logic Controller provides 8 output points in one group of eight with a common power output terminal. This output module is designed to have positive logic characteristics in that it sources current to the loads from the user common or positive power bus. The output device is connected between the negative power bus and the module output. The output characteristics are compatible with a wide range of user-supplied load devices, such as: motor starters, solenoids, and indicators. Power to operate the field devices must be supplied by the user.

LED indicators which provide the ON/OFF status of each point are located at the top of the module. This LED block has two horizontal rows with eight green LEDs in each row with the top row labeled A1 through 8 (points 1 through 8) and the bottom row labeled B1 through 8 (points 9 through 16). An insert goes between the inside and outside surface of the hinged door. The surface towards the inside of the module (when the hinged door is closed) has circuit wiring information, and circuit identification information can be recorded on the outside surface. The outside left edge of the insert is color-coded blue to indicate a low-voltage module. There are no fuses on this module.

This module can be installed in any I/O slot of a 5 or 10-slot baseplate in a Series 90-30 PLC system.

Table 7-9. Specifications for IC693MDL732

Rated Voltage	12/24 volts DC
Output Voltage Range	12 to 24 volts DC (+20%, -15%)
Outputs per Module	8 (one group of eight outputs)
Isolation	1500 volts between field side and logic side
Output Current	0.5 amps maximum per point 2 amps maximum per common
Output Characteristics	
Inrush Current	4.78 amps for 10 ms
Output Voltage Drop	1 volt maximum
Off-state Leakage	1 mA maximum
On Response Time	2 ms maximum
Off Response Time	2 ms maximum
Power Consumption	50 mA (all outputs on) from 5 volt bus on backplane

Refer to Appendix B for product standards and general specifications.

IC693MDL732 Output Module Field Wiring Information

The following figure provides wiring information for connecting user supplied load devices and power source to the 12/24 volt DC positive logic - 0.5 amp output module.

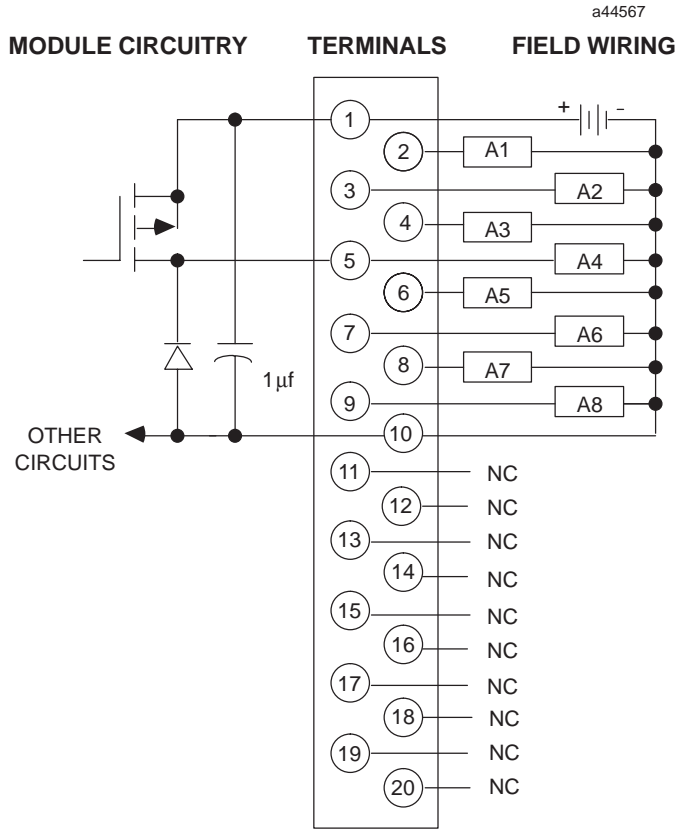

Figure 7-16. IC693MDL732 Output Module Field Wiring

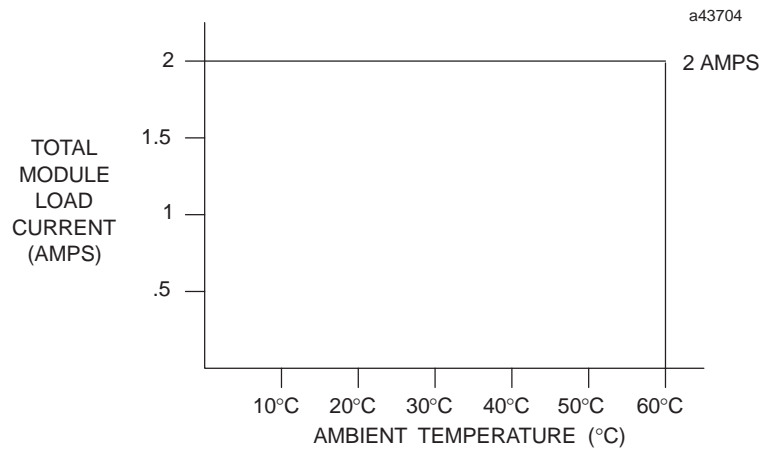

Figure 7-17. Load Current vs. Temperature for IC693MDL732

12/24 Volt DC Negative Logic 0.5 Amp Output - 8 Point IC693MDL733

The *12/24 volt DC Negative Logic 0.5 Amp Output* module for the Series 90-30 Programmable Logic Controller provides 8 output points in one group with a common power output terminal. This output module is designed to have negative logic characteristics in that it sinks current from the loads to the user common or negative power bus. The output device is connected between the positive power bus and the module output. The output characteristics are compatible with a wide range of user-supplied load devices, such as: motor starters, solenoids, and indicators. Power to operate the field devices must be supplied by the user.

LED indicators which provide the ON/OFF status of each point are located at the top of the module. This LED block has two horizontal rows with eight green LEDs in each row; the top row labeled A1 through 8 (points 1 through 8) is used by this module. An insert goes between the inside and outside surface of the hinged door. The surface towards the inside of the module (when the hinged door is closed) has circuit wiring information, and circuit identification information can be recorded on the outside surface. The outside left edge of the insert is color-coded blue to indicate a low-voltage module. There are no fuses on this module.

This module can be installed in any I/O slot of a 5 or 10-slot baseplate in a Series 90-30 PLC system.

Table 7-10. Specifications for IC693MDL733

Rated Voltage	12/24 volts DC
Output Voltage Range	12 to 24 volts DC (+20%, -15%)
Outputs per Module	8 (one group)
Isolation	1500 volts between field side and logic side
Output Current	0.5 amps maximum per point 2 amps maximum per common
Output Characteristics	
Output Voltage Drop	0.5 volts maximum
Off-state Leakage	1 mA maximum
On Response Time	2 ms maximum
Off Response Time	2 ms maximum
Power Consumption	50 mA (all outputs on) from 5 volt bus on backplane

Refer to Appendix B for product standards and general specifications.

IC693MDL733 Output Module Field Wiring Information

The following figure provides wiring information for connecting user supplied load devices and power source to the 8 point 12/24 volt DC negative logic 0.5 amp output module.

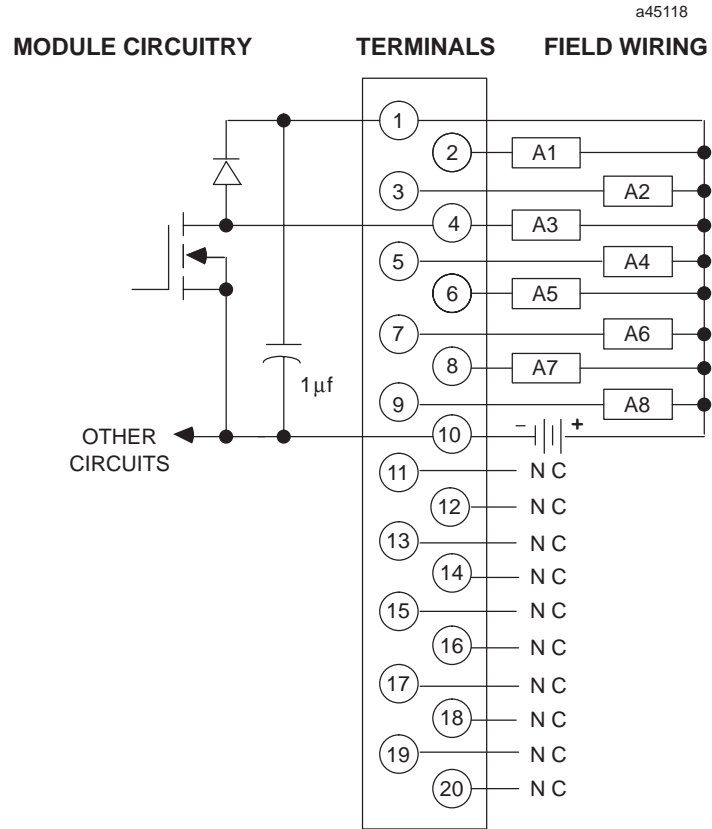

Figure 7-18. IC693MDL733 Output Module Field Wiring

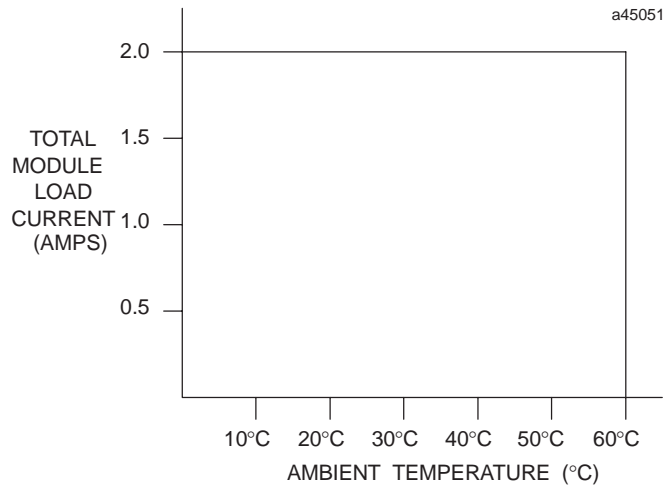

Figure 7-19. Load Current vs. Temperature for IC693MDL733

125 Volt DC Positive/Negative Logic 1 Amp Output - 6 Point IC693MDL734

The *125 volt DC Positive/Negative Logic 1 Amp Output* module for the Series 90-30 Programmable Logic Controller provides 6 isolated output points. Each output has a separate common output terminal associated with it. This output module is designed to have either *positive logic* characteristics in that it sources current to the loads from the user common or positive power bus; or *negative logic* characteristics in that it sinks current from the loads to the user common or negative power bus. The output characteristics are compatible with a wide range of user-supplied load devices, such as: motor starters, solenoids, and indicators. Power to operate the field devices must be supplied by the user.

LED indicators which provide the ON/OFF status of each point are located at the top of the module. This LED block has two horizontal rows with eight green LEDs in each row. This module uses the first six LEDs in the top row, labeled A1 through 6 (points 1 through 6) for output status. An insert goes between the inside and outside surface of the hinged door. The surface towards the inside of the module (when the hinged door is closed) has circuit wiring information, and circuit identification information can be recorded on the outside surface. The outside left edge of the insert is color-coded red to indicate a high-voltage module. External fusing is recommended. Two amp loads can be driven by wiring and driving two outputs in parallel.

This module can be installed in any I/O slot of a 5 or 10-slot baseplate in a Series 90-30 PLC system.

Table 7-11. Specifications for IC693MDL734

Rated Voltage	125 volts DC
Output Voltage Range	+10.8 to +150 volts DC
Outputs per Module	6 (isolated)
Isolation	1500 volts between field side and logic side 500 volts between outputs
Output Current	1 amp maximum per point
Output Characteristics	
Inrush Current	15.89 amps for 10 ms
Output Voltage Drop	1 volt maximum
Off-state Leakage	1 mA maximum
On Response Time	7 ms maximum
Off Response Time	5 ms maximum
Power Consumption	90 mA (all outputs on) from 5 volt bus on backplane

Refer to Appendix B for product standards and general specifications.

IC693MDL734 Output Module Field Wiring Information

The following figure provides wiring information for connecting user supplied load devices and power source to the 125 volt DC positive/negative logic 1 amp output module.

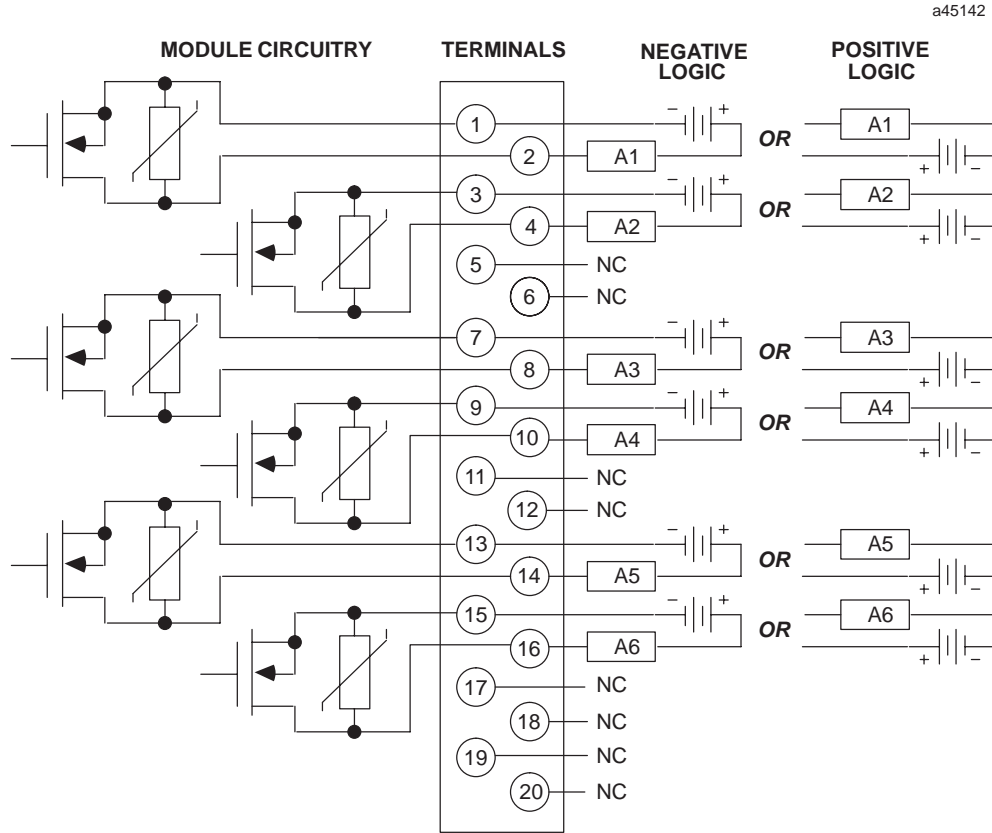

Figure 7-20. IC697MDL734 Output Module Field Wiring

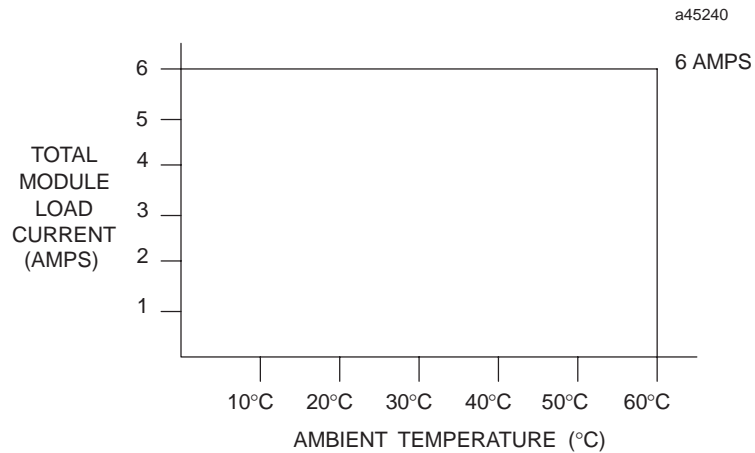

Figure 7-21. Load Current vs. Temperature for IC693MDL734

12/24 Volt DC Positive Logic Output - 0.5 Amp, 16 Point IC693MDL740

The *12/24 volt DC Positive Logic 0.5 Amp Output* module for the Series 90-30 Programmable Logic Controller provides 16 output points in two groups of eight with a common power output terminal for each group. This output module is designed to have positive logic characteristics in that it sources current to the loads from the user common or positive power bus. The output device is connected between the negative power bus and the module output. The output characteristics are compatible with a wide range of user-supplied load devices, such as: motor starters, solenoids, and indicators. Power to operate the field devices must be supplied by the user.

LED indicators which provide the ON/OFF status of each point are located at the top of the module. This LED block has two horizontal rows with eight green LEDs in each row with the top row labeled A1 through 8 (points 1 through 8) and the bottom row labeled B1 through 8 (points 9 through 16). An insert goes between the inside and outside surface of the hinged door. The surface towards the inside of the module (when the hinged door is closed) has circuit wiring information, and circuit identification information can be recorded on the outside surface. The outside left edge of the insert is color-coded blue to indicate a low-voltage module. There are no fuses on this module.

This module can be installed in any I/O slot of a 5 or 10-slot baseplate in a Series 90-30 PLC system.

Table 7-12. Specifications for IC693MDL740

Rated Voltage	12/24 volts DC
Output Voltage Range	12 to 24 volts DC (+20%, -15%)
Outputs per Module	16 (two groups of eight outputs each)
Isolation	1500 volts between field side and logic side 500 volts between groups
Output Current	0.5 amps maximum per point 2 amps maximum per common
Output Characteristics	
Inrush Current	4.78 amps for 10 ms
Output Voltage Drop	1 volt maximum
Off-state Leakage	1 mA maximum
On Response Time	2 ms maximum
Off Response Time	2 ms maximum
Power Consumption	110 mA (all outputs on) from 5 volt bus on backplane

Refer to Appendix B for product standards and general specifications.

IC693MDL740 Output Module Field Wiring Information

The following figure provides wiring information for connecting user supplied load devices and power source to the 12/24 volt DC positive logic - 0.5 amp output module.

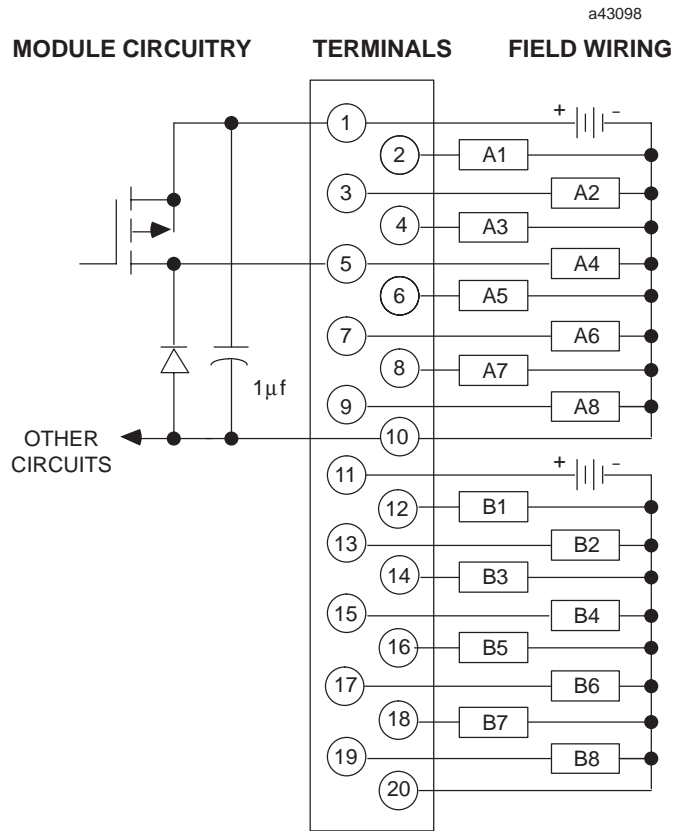

Figure 7-22. IC693MDL740 Output Module Field Wiring

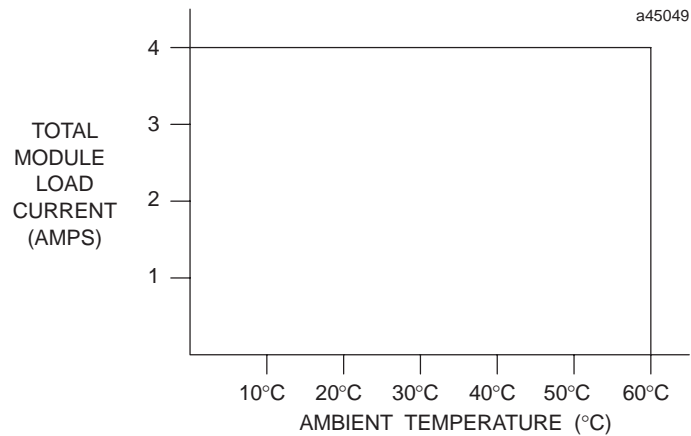

Figure 7-23. Load Current vs. Temperature for IC693MDL740

12/24 Volt DC Negative Logic 0.5 Amp Output - 16 Point IC693MDL741

The *12/24 volt DC Negative Logic 0.5 Amp Output* module for the Series 90-30 Programmable Logic Controller provides 16 output points in two groups. Each group has a common power output terminal. This output module is designed to have negative logic characteristics in that it sinks current from the loads to the user common or negative power bus. The output device is connected between the positive power bus and the module output. The output characteristics are compatible with a wide range of user-supplied load devices, such as: motor starters, solenoids, and indicators. Power to operate the field devices must be supplied by the user.

LED indicators which provide the ON/OFF status of each point are located at the top of the module. This LED block has two horizontal rows with eight green LEDs in each row; the top row labeled A1 through 8 (points 1 through 8) and the bottom row labeled B1 through 8 (points 9 through 16). An insert goes between the inside and outside surface of the hinged door. The surface towards the inside of the module (when the hinged door is closed) has circuit wiring information, and circuit identification information can be recorded on the outside surface. The outside left edge of the insert is color-coded blue to indicate a low-voltage module. There are no fuses on this module.

This module can be installed in any I/O slot of a 5 or 10-slot baseplate in a Series 90-30 PLC system.

Table 7-13. Specifications for IC693MDL741

Rated Voltage	12/24 volts DC
Output Voltage Range	12 to 24 volts DC (+20%, -15%)
Outputs per Module	16 (two groups of eight outputs each)
Isolation	1500 volts between field side and logic side 500 volts between groups
Output Current	0.5 amps maximum per point 2 amps maximum per common
Output Characteristics	
Output Voltage Drop	0.5 volts maximum
Off-state Leakage	1 mA maximum
On Response Time	2 ms maximum
Off Response Time	2 ms maximum
Power Consumption	110 mA (all outputs on) from 5 volt bus on backplane

Refer to Appendix B for product standards and general specifications.

IC693MDL741 Output Module Field Wiring Information

The following figure provides wiring information for connecting user supplied load devices and power source to the 12/24 volt DC negative logic 0.5 amp output module.

a43100

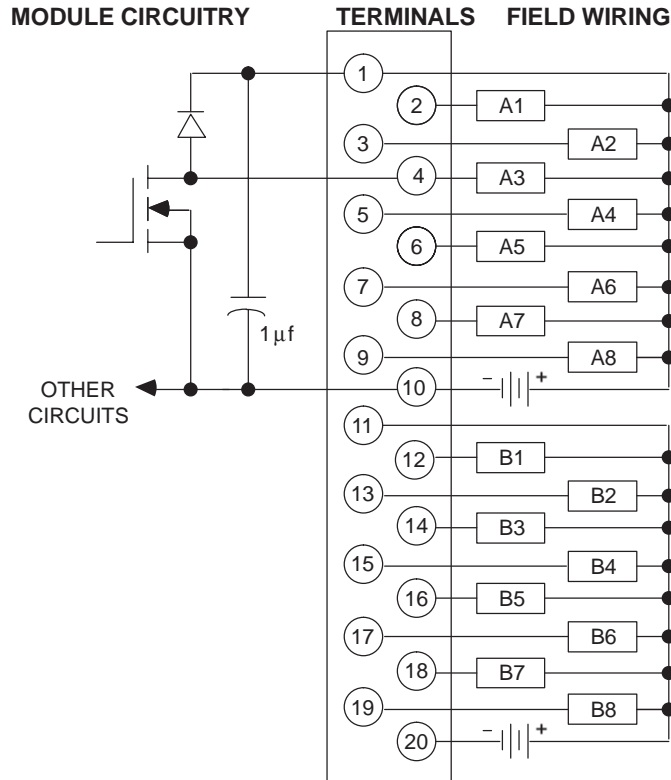

Figure 7-24. IC693MDL741 Output Module Field Wiring

a45049

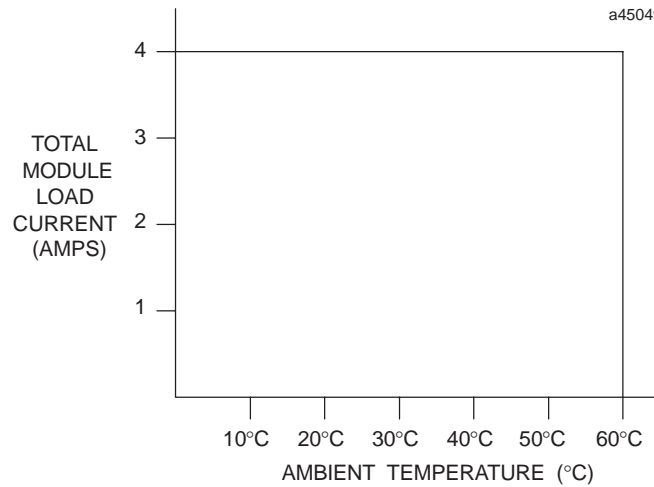

Figure 7-25. Load Current vs. Temperature for IC693MDL741

12/24 Volt DC Positive Logic ESCP Output - 1 Amp, 16 Point IC693MDL742

The *12/24 volt DC Positive Logic 1 Amp Electronic Short Circuit Protection (ESCP) Output* module for the Series 90-30 PLC provides 16 output points in two groups of eight with a common power output terminal for each group. This output module is designed to have positive logic characteristics in that it sources current to the loads from the user common or positive power bus. The output device is connected between the negative power bus and the module output. The output characteristics are compatible with a wide range of user-supplied load devices, such as: motor starters, solenoids, and indicators. Power to operate the field devices must be supplied by the user.

LED indicators that provide the ON/OFF status of each point are located at the top of the module. This LED block has two horizontal rows with eight green LEDs in each row with the top row labeled A1 - A8 (points 1 through 8) and the bottom row labeled B1 - B8 (points 9 through 16). A red LED (labeled "F") on the right, centered between the two rows of green LEDs, functions as a tripped electronic short circuit protection indicator; it turns ON when any short circuit protection trip occurs. The common signal for each group is monitored electronically. If a short circuit occurs, the output points in the group turn off and the red LED turns on. The LEDs indicating output point status will not turn off. This protection does not protect individual outputs from exceeding their ratings, but will protect the board in case of a short circuited load. To reset electronic short circuit protection remove the 12/24 VDC user supply to the module. The module has two electronic short circuit protection circuits; each protects eight outputs - the first circuit protects A1 - A8, the second circuit protects B1 - B8.

An insert goes between the inside and outside surface of the hinged door. The surface towards the inside of the module (when the hinged door is closed) has circuit wiring information, and circuit identification information can be recorded on the outside surface. The outside left edge of the insert is color-coded blue to indicate a low-voltage module. There are no fuses on this module. This module can be installed in any I/O slot of a 5 or 10-slot baseplate in a Series 90-30 PLC system.

Table 7-14. Specifications for IC693MDL742

Rated Voltage	12/24 volts DC
Output Voltage Range	12 to 24 volts DC (+20%, -15%)
Outputs per Module	16 (two groups of eight outputs each)
Isolation	1500 volts between field side and logic side
	500 volts between groups
Output Current †	1 amp maximum per point 4 amps maximum per group at @ 50°C 3 amps maximum per group @ 60°C
Output Characteristics	
Inrush Current	5.2 amps for 10 ms
Output Voltage Drop	1.2 volts maximum
Off-state Leakage	1 mA maximum
On Response Time	2 ms maximum
Off Response Time	2 ms maximum
Power Consumption	130 mA (all outputs on) from 5 volt bus on backplane

† Maximum load current is dependent upon ambient temperature as shown in graph on following page.
Refer to Appendix B for product standards and general specifications.

IC693MDL742 Output Module Field Wiring Information

The following figure provides wiring information for connecting user supplied load devices and power source to the 12/24 volt DC positive logic ESCP - 1 amp output module.

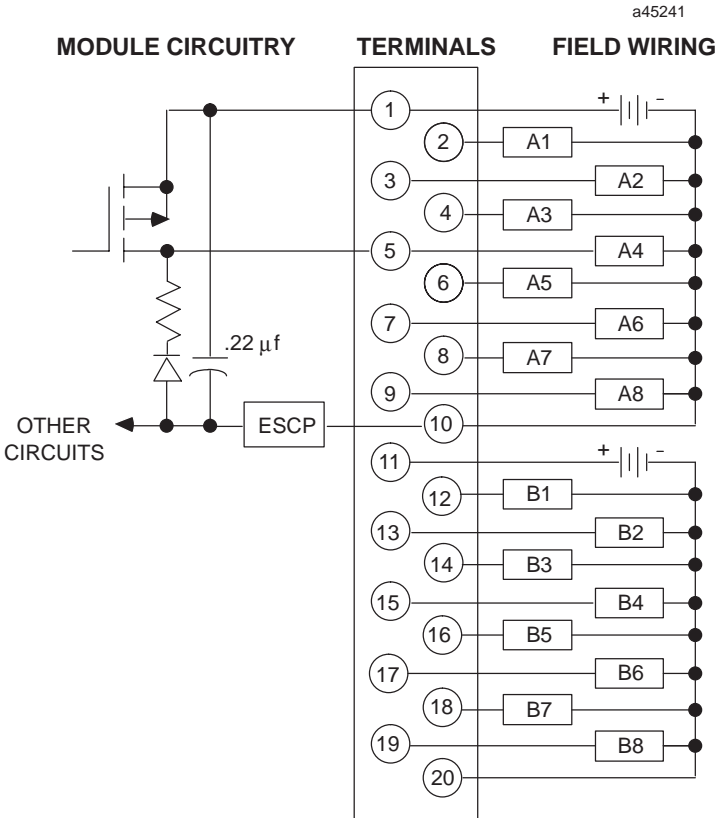

Figure 7-26. IC693MDL742 Output Module Field Wiring

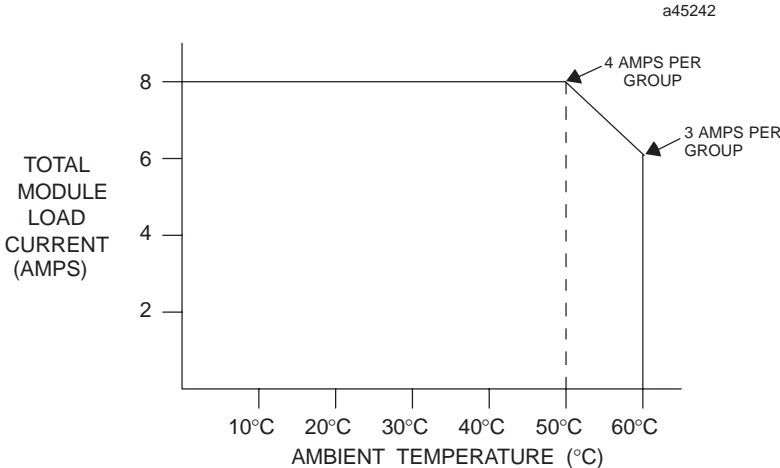

Figure 7-27. Load Current vs. Temperature for IC693MDL742

Isolated Relay Output, N.O., 4 Amp - 8 Point IC693MDL930

The *4 Amp Isolated Relay Output* module for the Series 90-30 Programmable Logic Controller provides 8 normally-open relay circuits for controlling output loads provided by the user. The output switching capacity of each circuit is 4 amps. Each output point is isolated from the other points, and each point has a separate common power output terminal. The relay outputs can control a wide range of user-supplied load devices, such as: motor starters, solenoids, and indicators. The user must supply the AC or DC power to operate the field devices connected to this module. There are no fuses on this module.

LED indicators which provide the ON/OFF status of each point are located at the top of the module. The LEDs are arranged in two horizontal rows with eight green LEDs in each row. This module uses the top row labeled A1 through 8 (points 1 through 8); the bottom row is not used. An insert goes between the inside and outside surface of the hinged door. The surface towards the inside of the module (when the hinged door is closed) has circuit wiring information, and circuit identification information can be recorded on the outside surface. The outside left edge of the insert is color-coded red to indicate a high-voltage module. This module can be installed in any I/O slot of a 5 or 10-slot baseplate in a Series 90-30 PLC system.

Table 7-15. Specifications for IC693MDL930

Rated Voltage	24 volts DC, 120/240 volts AC (nominal – see the following table for exceptions)
Operating Voltage	5 to 30 volts DC 5 to 250 volts AC, 50/60 Hz
Outputs per Module	8 isolated outputs
Isolation	1500 volts between field side and logic side 500 volts between groups
Maximum Load †	4 amps resistive maximum per output 2 amps pilot duty per output 20 amps maximum per module for UL installations
Minimum Load	10 mA
Maximum Inrush	5 amps
On Response Time	15 ms maximum
Off Response Time	15 ms maximum
Int. Power Consumption	6 mA (all outputs on) from 5 volt bus on backplane 70 mA (all outputs on) from relay 24V bus on backplane

† Maximum load current is dependent upon ambient temperature as shown in graph on following page.

Refer to Appendix B for product standards and general specifications.

IC693MDL930 Output Module Field Wiring Information

The following figure provides wiring information for connecting user supplied load devices and power source to the 4 amp Relay Output module.

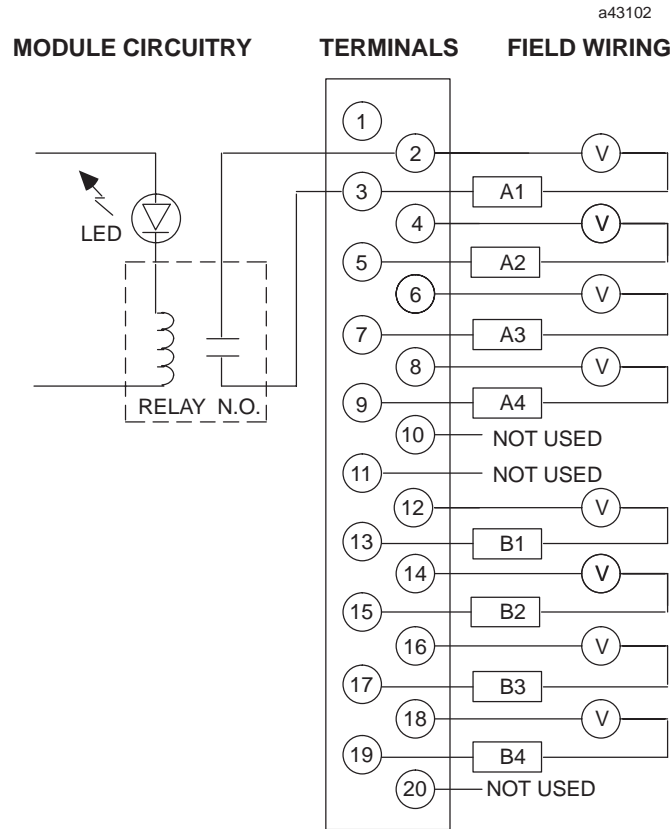

Figure 7-28. IC693MDL930 Output Module Field Wiring

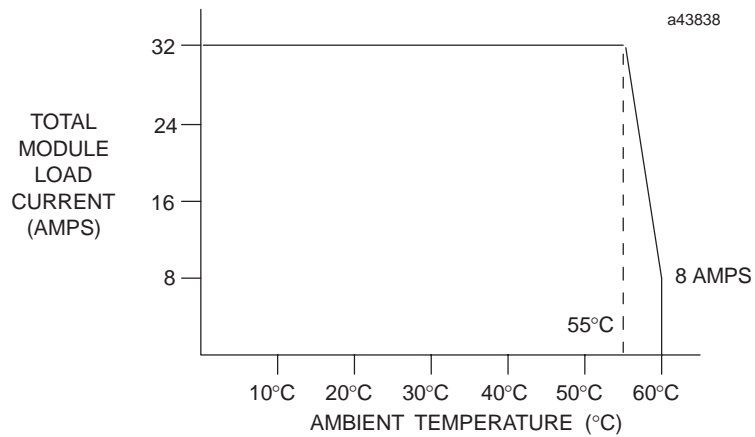

Figure 7-29. Load Current vs. Temperature for IC693MDL930

Table 7-16. Load Current Limitations for IC693MDL930

Operating Voltage	Maximum Current for Load Type		Typical Contact Life (number of Operations)
	Resistive	Lamp or Solenoid †	
24 to 120 VAC	4 amps	2 amps	150,000
24 to 120 VAC	1 amp	.5 amps	500,000
24 to 120 VAC	.1 amps	.05 amps	1,000,000
240 VAC	4 amps	2 amps	50,000
240 VAC	.1 amps	.05 amps	500,000
240 VAC	1 amp	.5 amps	200,000
24 VDC	-	3 amps	50,000
24 VDC	4 amps	2 amps	100,000
24 VDC	1 amp	.5 amps	500,000
24 VDC	.1 amps	.05 amps	1,000,000
125 VDC	.2 amps	.1 amps	300,000

† Assumes a 7 ms time constant

Relay contact life, when switching inductive loads, will approach resistive load contact life if suppression circuits are used. The following figures are examples of typical suppression circuits for AC and DC loads. The 1A, 200V diode shown in the DC load typical suppression example is an industry standard 1N4935. The resistor and capacitor shown for AC load suppression are standard components, available from most electronics distributors.

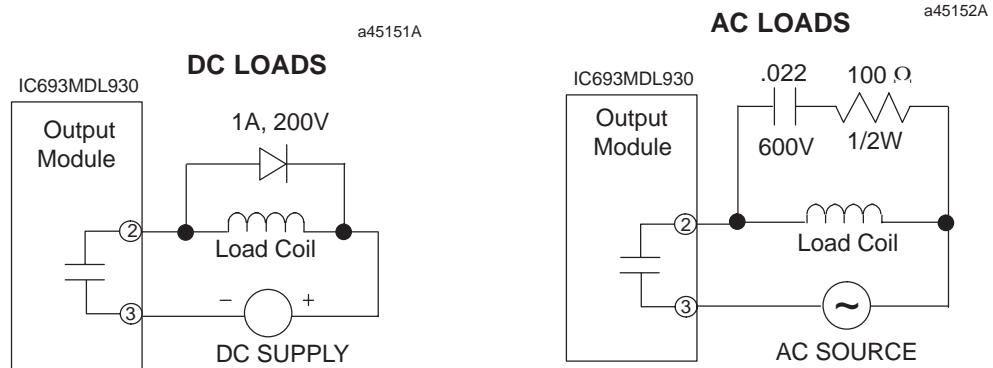

Figure 7-30. Load Suppression Examples for IC693MDL930 Output Module

Isolated Relay Output, N.C. and Form C, 8 Amp - 8 Point IC693MDL931

This **8 Amp Isolated Relay Output** module for the Series 90-30 Programmable Logic Controller provides 4 normally-closed and 4 Form C relay circuits for controlling output loads provided by the user. The output switching capacity of each circuit is 8 amps for the normally-closed contacts or the normally open contacts. Each output relay is isolated from the other relays, and each relay has a separate common power output terminal. The relay outputs can control a wide range of user-supplied load devices, such as: motor starters, solenoids, and indicators. The user must supply the AC or DC power to operate the field devices connected to this module. There are no fuses on this module.

LED indicators which provide the ON/OFF status of each point are located at the top of the module. The LEDs are arranged in two horizontal rows with eight green LEDs in each row. This module uses the top row labeled A1 through 8 (points 1 through 8) for output status; the bottom row is not used and the fuse LED is not used. An insert goes between the inside and outside surface of the hinged door. The surface towards the inside of the module (when the hinged door is closed) has circuit wiring information, and circuit identification information can be recorded on the outside surface. The outside left edge of the insert is color-coded red to indicate a high-voltage module. This module can be installed in any I/O slot of a 5 or 10-slot baseplate in a Series 90-30 PLC system.

Table 7-17. Specifications for IC693MDL931

Rated Voltage	24 volts DC, 120/240 volts AC, 50/60 Hz (nominal – see the following table for exceptions)
Output Voltage Range	5 to 30 volts DC 5 to 250 volts AC, 50/60 Hz
Outputs per Module	8 isolated outputs
Isolation	1500 volts between field side and logic side 500 volts between groups
Maximum Load †	8 amps resistive maximum per output 20 amps maximum per module for UL installations
Minimum Load	10 mA
Inrush Current	8 amps maximum for one cycle
On Response Time	15 ms maximum
Off Response Time	15 ms maximum
Output Leakage Current	1 mA maximum at 250 volts AC, (25°C (77°F))
Internal Power Consumption	45 mA (all outputs on) from 5 volt bus on backplane 100 mA (all outputs on) from relay 24V bus on backplane

† Maximum load current is dependent upon ambient temperature as shown in graph on following page.

Refer to Appendix B for product standards and general specifications.

IC693MDL931 Output Module Field Wiring Information

The following figure provides wiring information for connecting user supplied load devices and power source to the 8 amp Isolated Relay Output module.

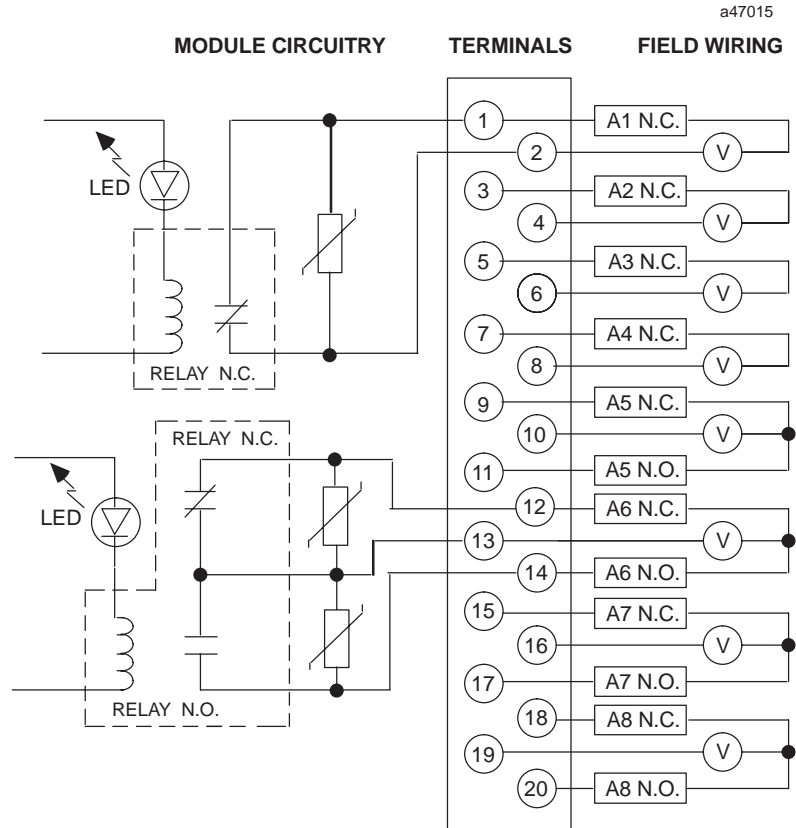

Figure 7-31. IC693MDL931 Output Module Field Wiring

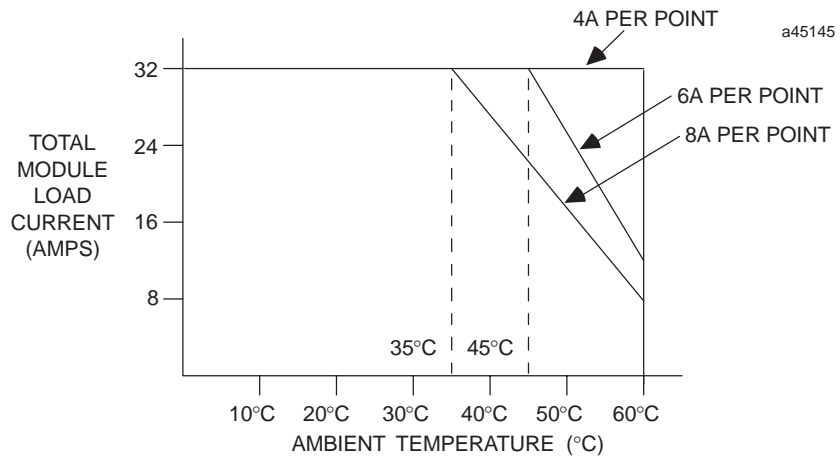

Figure 7-32. Load Current vs. Temperature for IC693MDL931

Table 7-18. Load Current limitations for IC693MDL931

Operating Voltage	Maximum Current for Load Type		Typical Contact Life (number of operations)
	Resistive	Lamp or Solenoid †	
5 to 120 VAC	8 amps	3 amps	200,000
	6 amps	2.5 amps	300,000
	4 amps	1.5 amps	400,000
	1 amp	0.5 amps	1,100,000
240 VAC	8 amps	3 amps	100,000
	6 amps	2.5 amps	150,000
	4 amps	1.5 amps	200,000
	1 amp	0.5 amps	800,000
24 VDC	8 amps	3 amps	100,000
	6 amps	2.5 amps	150,000
	4 amps	1.5 amps	200,000
	1 amp	0.5 amps	800,000
48 VDC	1.5 amps	-	100,000
100 VDC	0.5 amps	-	100,000
125 VDC	0.38 amps	0.12 amps	100,000
150 VDC	0.30 amps	0.10 amps	100,000

† For inductive loads

Relay contact life, when switching inductive loads, will approach resistive load contact life if suppression circuits are used. The following figures are examples of typical suppression circuits for AC and DC loads. The 1A, 200V diode shown in the DC load typical suppression circuit is an industry standard 1N4935. The resistor and capacitor shown for AC load suppression are standard components, available from most electronics distributors.

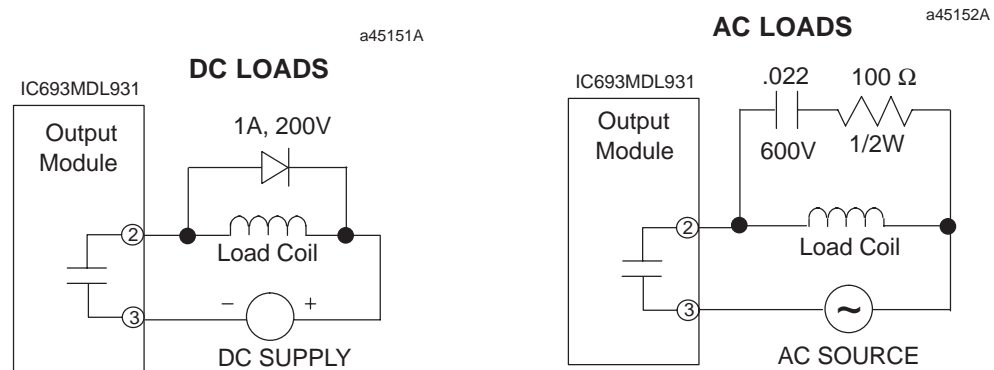

Figure 7-33. Load Suppression Examples for IC693MDL931 Output Module

Relay Output, N.O., 2 Amp - 16 Point IC693MDL940

The *2 Amp Relay Output* module for the Series 90-30 Programmable Logic Controller provides 16 normally-open relay circuits for controlling output loads provided by the user. The output switching capacity of each output is 2 amps. The output points are arranged in four groups of four points each. Each group has a common power output terminal. The relay outputs can control a wide range of user-supplied load devices, such as: motor starters, solenoids, and indicators. Power for the internal relay circuits is provided by the +24 volt DC bus on the backplane. The user must supply the AC or DC power to operate field devices. There are no fuses on this module.

LED indicators which provide the ON/OFF status of each point are located at the top of the module. The LEDs are arranged in two horizontal rows with eight green LEDs in each row; the top row labeled A1 through 8 (points 1 through 8) and the bottom row labeled B1 through 8 (points 9 through 16). An insert goes between the inside and outside surface of the hinged door. The surface towards the inside of the module (when the hinged door is closed) has circuit wiring information, and circuit identification information can be recorded on the outside surface. The outside left edge of the insert is color-coded red to indicate a high-voltage module. This module can be installed in any I/O slot of a 5 or 10-slot baseplate in a Series 90-30 PLC system.

Table 7-19. Specifications for IC693MDL940

Rated Voltage	24 volts DC, 120/240 volts AC (nominal – see the following table for exceptions)
Operating Voltage	5 to 30 volts DC 5 to 250 volts AC, 50/60 Hz
Outputs per Module	16 (four groups of four outputs each)
Isolation	1500 volts between field side and logic side 500 volts between groups
Maximum Load	2 amps pilot duty maximum per output 4 amps maximum per common
Minimum Load	10 mA
Maximum Inrush	5 amps
On Response Time	15 ms maximum
Off Response Time	15 ms maximum
Int. Power Consumption	7 mA (all outputs on) from 5 volt bus on backplane 135 mA (all outputs on) from relay 24V bus on backplane

Refer to Appendix B for product standards and general specifications.

IC693MDL940 Output Module Field Wiring Information

The following figure provides wiring information for connecting user supplied load devices and power source to the 2 amp N.O. Relay output module.

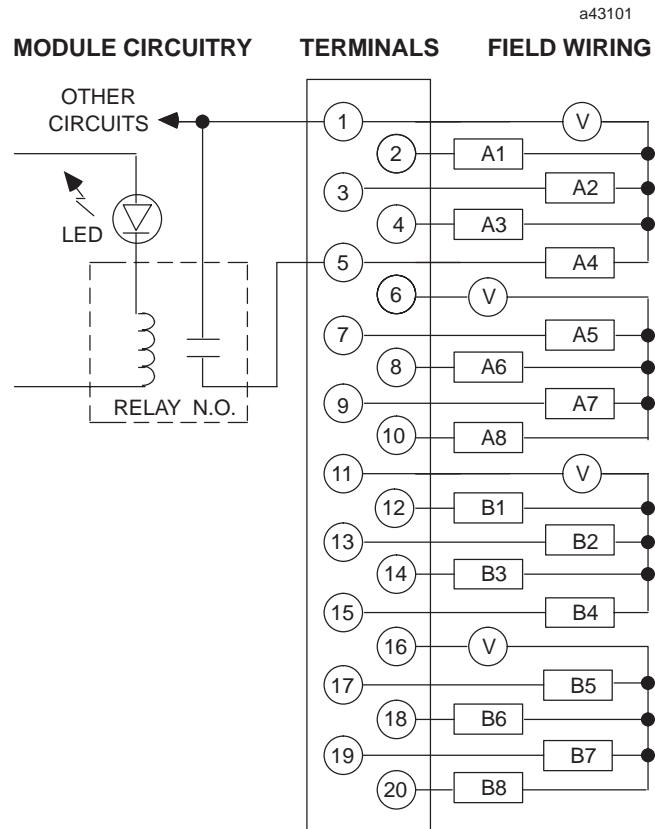

Figure 7-34. IC693MDL940 Output Module Field Wiring

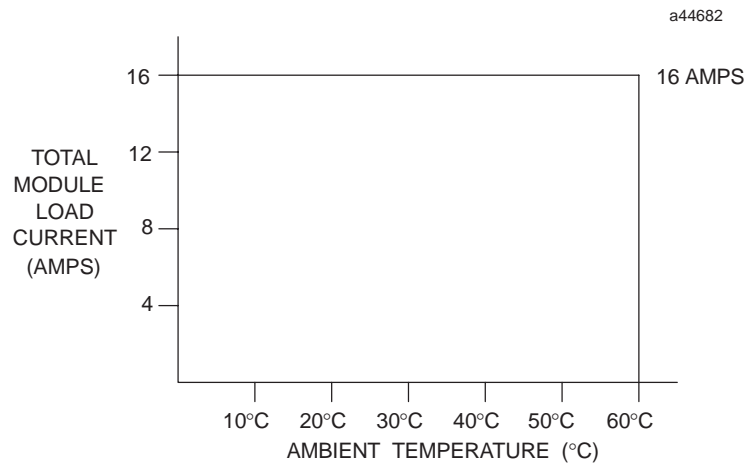

Figure 7-35. Load Current vs. Temperature for IC693MDL940

Table 7-20. Load Current Limitations for IC693MDL940

Operating Voltage	Maximum Current for Load Type		Typical Contact Life (Number of Operations)
	Resistive	Lamp or Solenoid †	
24 to 120 VAC	2 amps	1 amp	300,000
24 to 120 VAC	1 amp	.5 amps	500,000
24 to 120 VAC	.1 amps	.05 amps	1,000,000
240 VAC	2 amps	1 amp	150,000
240 VAC	1 amp	.5 amps	200,000
240 VAC	.1 amps	.05 amps	500,000
24 VDC	-	2 amps	100,000
24 VDC	2 amps	1 amp	300,000
24 VDC	1 amp	.5 amps	500,000
24 VDC	.1 amps	.05 amps	1,000,000
125 VDC	.2 amps	.1 amps	300,000

† Assumes a 7 ms time constant

Relay contact life, when switching inductive loads, will approach resistive load contact life if suppression circuits are used. The following figures are examples of typical suppression circuits for AC and DC loads. The 1A, 200V diode shown in the DC load suppression circuit is an industry standard 1N4935. The resistor and capacitor shown for AC load suppression are standard components, available from most electronics distributors.

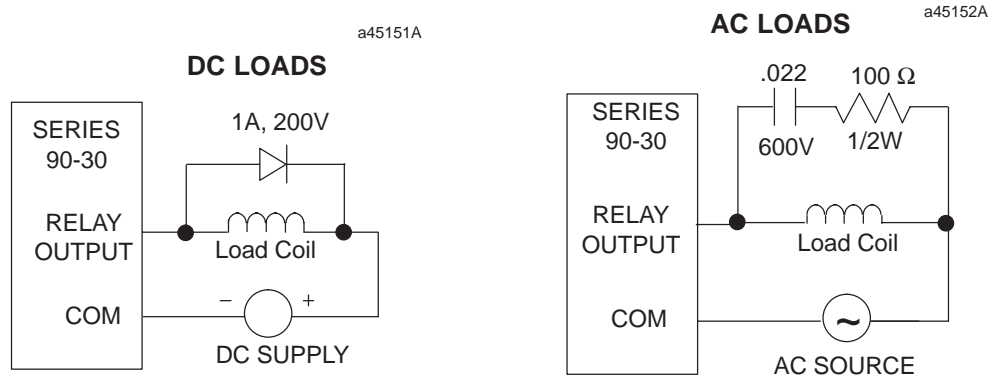

Figure 7-36. Load Suppression Examples for IC693MDL940 Output Module

12/24 Volt DC Negative Logic Output, 32 Point IC693MDL750

The *12/24 volt DC Negative Logic Output* module for the Series 90-30 Programmable Logic Controller provides 32 output points in four groups of eight with two common pins for each group. The Output module is designed to have negative logic characteristics in that it sinks current from the loads to the user common or negative power bus. The output device is connected between the positive power bus and the module output. The output characteristics are compatible with a wide range of user-supplied load devices, such as motor starters, solenoids, and indicators. Power to operate the field devices must be supplied by the user.

Connections from the output circuits are made to the user's output devices through a 50-pin connector mounted on the front of the module.

This module does not have LED indicators to indicate circuit status. This output module can be installed in any I/O slot of a 5 or 10-slot baseplate in a Series 90-30 PLC system.

Table 7-21. Specifications for IC693MDL750

Rated Voltage	12/24 volts DC
Output Voltage Range	12 to 24 volts DC (+20%, -15%)
Outputs per Module	32 (four groups of eight outputs each)
Isolation	1500 volts between field side and logic side
Output Current	0.3 amps maximum per point 2 amps maximum per common at 60°C (140°F)
Output Characteristics	
Output Voltage Drop	0.24 volts maximum
Off-state Leakage	0.1 mA maximum
On Response Time	2 ms maximum
Off Response Time	2 ms maximum
Internal Power Consumption	21 mA (all outputs on) from 5 volt bus on backplane

Refer to Appendix B for product standards and general specifications.

Wiring to Field Devices

- **Direct Method** – This method uses cables that have a mating female connector on the module end and stripped and tinned wires on the other end. You can purchase a pre-wired cable, either catalog number IC693CBL308 (3 feet/1 meter) or catalog number IC693CBL309 (6 feet/2 meters) or, if required for your application, build your own cables. Refer to the IC693CBL308/309 data sheet in Appendix C of this manual for cable information.
- **Using a Weidmuller Terminal Block** – You may purchase a Weidmuller #912263 terminal block from your electronics dealer to use with a GE Fanuc prewired cable. GE Fanuc Cables IC693CBL306 (3 feet/1meter) or IC693CBL307 (6 feet/2 meters) have connectors on each end. These connect from the module connector to a connector on the DIN-rail mounted Weidmuller terminal block. Appendix C has a data sheet for these cables, which includes a figure showing how they connect between the module and the Weidmuller terminal block.

Field Wiring Information

The following figure provides wiring information for connecting user supplied load devices and power source to the 12/24 volt DC negative logic 32 point output module.

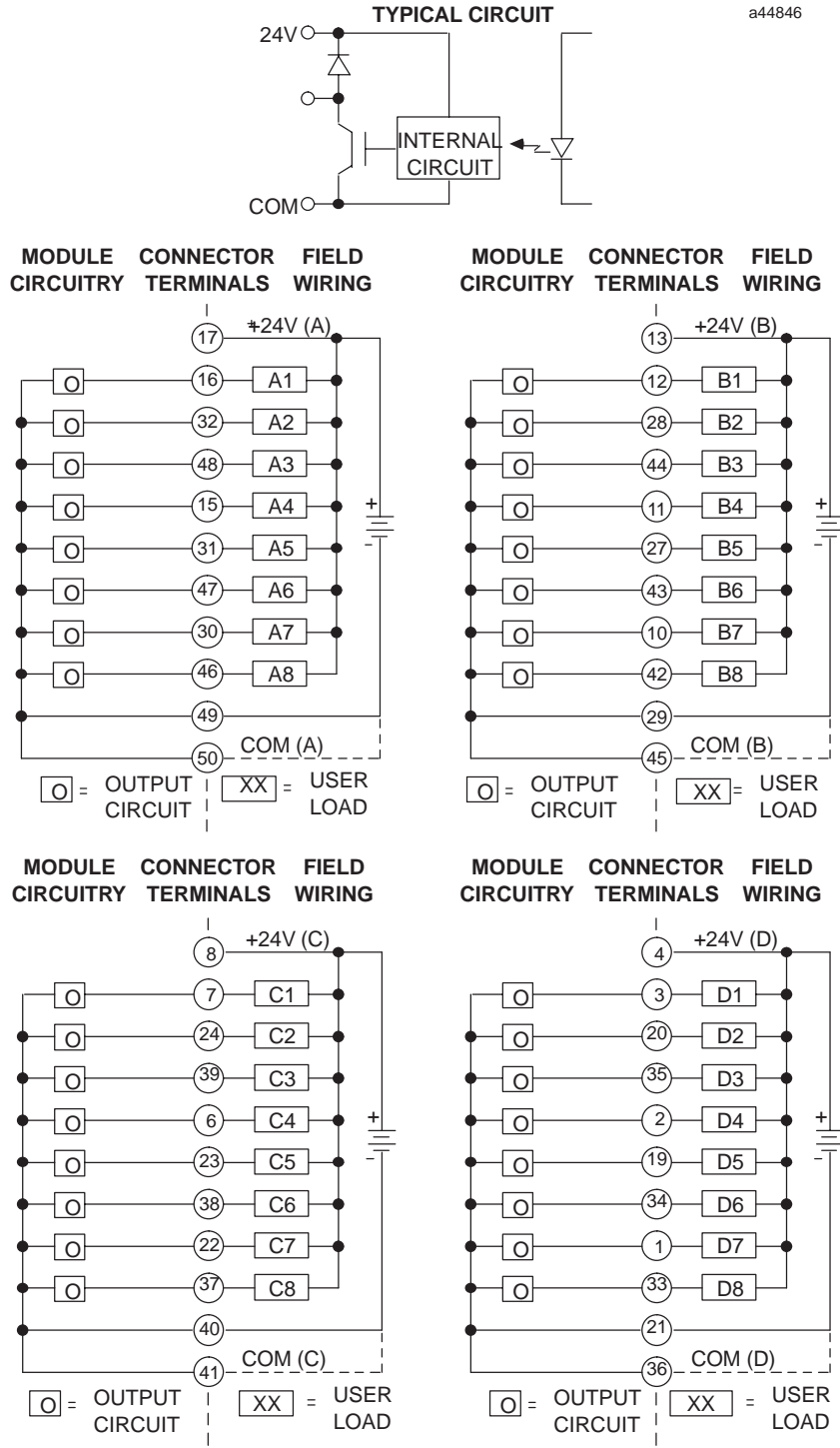

Figure 7-37. Field Wiring - 12/24 Volt DC Negative Logic 32 Point Output Module, IC693MDL750

12/24 Volt DC Positive Logic Output, 32 Point IC693MDL751

The *12/24 volt DC Positive Logic Output* module for the Series 90-30 Programmable Logic Controller provides 32 outputs in four groups of eight with two common pins for each group. The Output module is designed to have positive logic characteristics in that it sources current to the loads from the user common or positive power bus. The output device is connected between the negative power bus and the module output. The output characteristics are compatible with a wide range of user-supplied load devices, such as motor starters, solenoids, and indicators. Power to operate the field devices must be supplied by the user.

Connections from the output circuits are made to the user's output devices through a 50-pin connector mounted on the front of the module.

This module does not have LED indicators to indicate circuit status. This output module can be installed in any I/O slot of a 5 or 10-slot baseplate in a Series 90-30 PLC system.

Table 7-22. Specifications for IC693MDL751

Rated Voltage	12/24 volts DC
Output Voltage Range	12 to 24 volts DC (+20%, -15%)
Outputs per Module	32 (four groups of eight outputs each)
Isolation	1500 volts between field side and logic side
Output Current	0.3 amps maximum per point 2 amps maximum (each common)
Output Characteristics	
Output Voltage Drop	0.24 volts maximum
Off-state Leakage	0.1 mA maximum
On Response Time	2 ms maximum
Off Response Time	2 ms maximum
Internal Power Consumption	21 mA (all outputs on) from 5 volt bus on backplane

Refer to Appendix B for product standards and general specifications.

Wiring to Field Devices

- **Direct Method** – This method uses cables that have a mating female connector on the module end and stripped and tinned wires on the other end. You can purchase a pre-wired cable, either catalog number IC693CBL308 (3 feet/1 meter) or catalog number IC693CBL309 (6 feet/2 meters) or, if required for your application, build your own cables. Refer to the IC693CBL308/309 data sheet in Appendix C of this manual for cable information.
- **Using a Weidmuller Terminal Block** – You may purchase a Weidmuller #912263 terminal block from your electronics dealer to use with a GE Fanuc prewired cable. GE Fanuc Cables IC693CBL306 (3 feet/1meter) or IC693CBL307 (6 feet/2 meters) have connectors on each end. These connect from the module connector to a connector on the DIN-rail mounted Weidmuller terminal block. Appendix C has a data sheet for these cables, which includes a figure showing how they connect between the module and the Weidmuller terminal block.

IC693MDL751 Output Module Field Wiring Information

The following figure provides wiring information for connecting user supplied load devices and power source to the 12/24 volt DC positive logic output module.

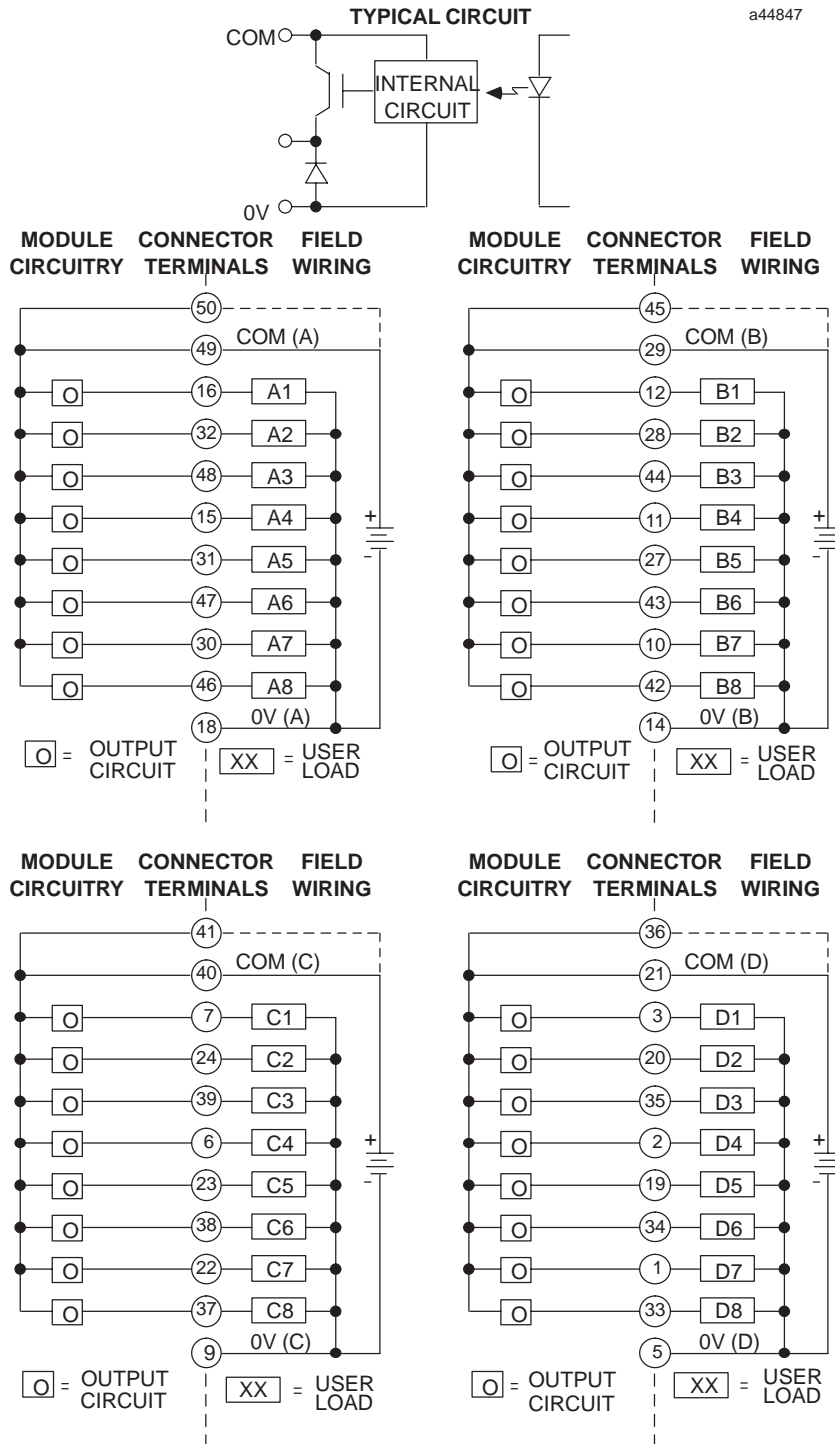

Figure 7-38. Field Wiring - IC693MDL751 32 Point Output Module

5/24 Volt DC (TTL) Negative Logic Output, 32 Point IC693MDL752

The *5/24 volt DC (TTL) Negative Logic Output* module for the Series 90-30 Programmable Logic Controller provides 32 discrete outputs. The outputs are arranged in four isolated groups of eight (A1 - A8, B1 - B8, C1 - C8, and D1 - D8); each group has its own common. The outputs are negative logic or sinking type outputs (i.e., the ON state for a point results in an active low output).

The module has two modes of operation. In the TTL mode, the outputs can switch user loads across +5 VDC ($\pm 5\%$) and are capable of sinking a maximum current of 25 mA per point. In the 12/24V mode, the outputs can switch user loads over the range of +12 through -24 VDC (+20%, -15%) and are capable of sinking a maximum current of 0.5A per point. Two pins are provided on the user I/O connectors for each group common. Each pin has a current handling capability of 3 amperes. It is recommended that connections are made to both pins when connecting the common; however, it is a requirement for high current applications (between 3 and 4 amperes).

Each group can be used in the mode of operation needed to satisfy the load requirements for a particular application. For example, group A can drive TTL loads and group B can drive 12 VDC loads, while group C and D can be reserved for driving 24 VDC loads. It is important to note, however that the effects of electrical noise must be considered when mixing TTL and inductive-type loads.

An internal pull-up resistor is provided for each point. The function of each resistor is to passively pull up the output to the user positive side power input (typically +5V for TTL mode) when the output point FET is OFF, thereby providing a high logic level for TTL applications. All 32 outputs are forced OFF when the CPU is stopped. Power to provide current to the loads must be provided by the user. The module also draws a minimum amount of power from the user supply to provide gate drive to the output devices.

Backplane isolation between the field side and logic side is provided by opto-couplers on the module. No special fault or alarm diagnostics are reported. LED indicators (labeled A1 - A8, B1 - B8, C1 - C8, D1 - D8) at the top of the module provide the ON/OFF status of each output point.

This module is configured as a 32-point output type and uses 32 bits of discrete %Q output data. This module can be installed in any I/O slot of a 5 or 10-slot baseplate in a Series 90-30 PLC system.

Connections to the output circuits are made from the user's load devices to two male (pin-type) 24-pin connectors (Fujitsu FCN-365P024-AU) mounted on the front of the module. The connector mounted on the right of the module (front view) interfaces with groups A and B. The connector on the left side of the module interfaces with groups C and D.

Wiring to Field Devices

- **Direct Method** – This method uses cables that have a mating female connector on the module end and stripped and tinned wires on the other end. You can purchase a pair of pre-wired cables, catalog numbers IC693CBL327 and IC693CBL328 or, if required for your application, build your own cables. Refer to *Building Cables for 24-Pin Connectors* in the IC693CBL327/328 data sheet in Appendix C of this manual for more information.
- **Using a TBQC** – The Terminal Block Quick Connect method uses a pair of cables with connectors on each end. These connect from the module connectors to connectors on DIN-rail mounted terminal blocks. The TBQC components are discussed in Appendix D.

Table 7-23. Specifications for IC693MDL752

Rated Voltage	5, and 12 through 24 volts DC, negative logic (active low)
Output Voltage Range	4.75 to 5.25 volts DC (TTL mode) 10.2 to 28.8 volts DC (12/24V mode)
Outputs per Module	32 (four groups of eight outputs each)
Isolation	1500 volts between field side and logic side 250 volts between groups
Output Current	25 mA per point (maximum in TTL mode) 0.5 amps per point (maximum in 12/24V mode); with 4 amps maximum per group and 3 amps maximum per group common pin
Output Characteristics	
Inrush Current	4.6 amps for 10 ms
On-state (active low)	0.4 volts DC (maximum in TTL mode)
Voltage Drop	0.24 volts DC (maximum in 12/24V mode)
Off-state Leakage Current	0.1 mA maximum
On Response Time	0.5 ms maximum
Off Response Time	0.5 ms maximum
Internal Power Consumption	260 mA (maximum) from 5 volt bus on backplane; (13 mA + 3 mA/point ON + 4.7 mA/LED) 12 mA (maximum) per group from user supply @ 5VDC and all eight outputs in group ON 25 mA (maximum) per group from user supply @ 12 VDC and all eight outputs in group ON 44 mA (maximum) per group from user supply @ 24 VDC and all eight outputs in group ON

Refer to Appendix B for product standards and general specifications.

IC693MDL752 Output Module Field Wiring Information

The following three figures provide wiring information for connecting user supplied load devices and power source to the 5/24 volt DC negative logic output module.

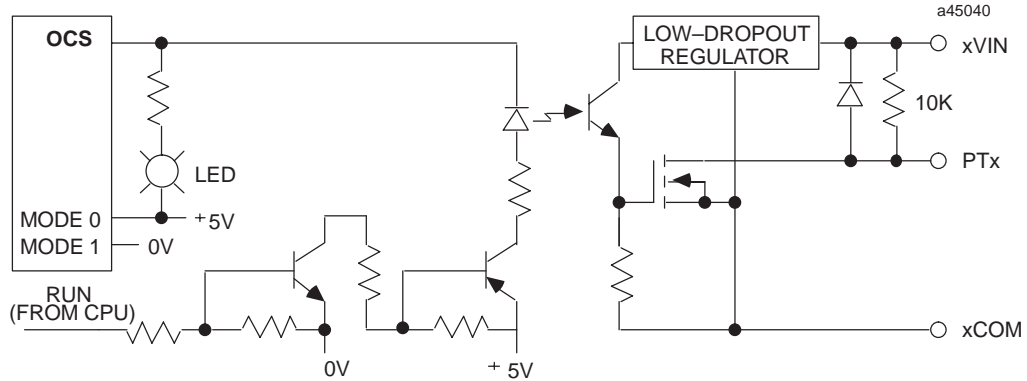

Module point numbers in the following figure are shown in **bold text**.

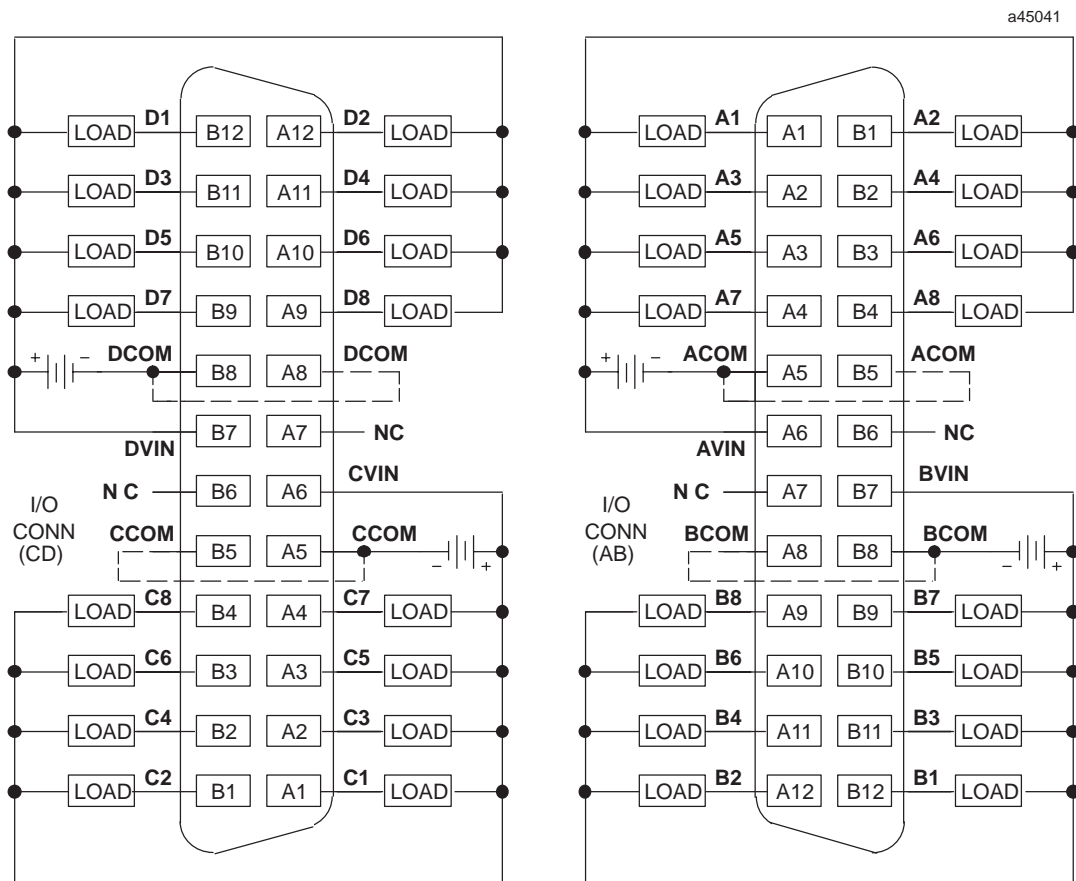

= FUJITSU CONNECTOR PINS A1 – A12, B1 – B12 MODULE POINT NUMBERS ARE SHOWN IN **BOLD TEXT**.

Figure 7-39. Field Wiring - 5/24 Volt DC (TTL) Neg. Logic 32 Point Output Module - IC693MDL752

The following figure provides examples of typical connections to user loads from the 5/24 VDC (TTL) Negative Logic Output module.

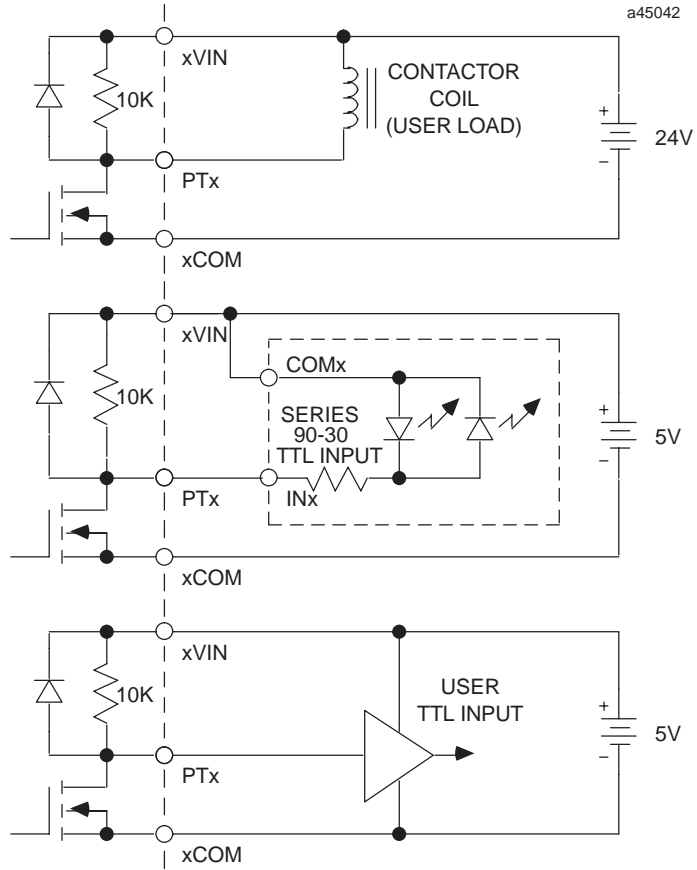

Figure 7-40. Examples of Connections to User Loads

Field Wiring Work Sheet for IC693MDL752

The following table is provided for the convenience of our customers as an aid to wiring the 24-pin connectors using cable IC693CBL315. It includes all of the required wiring information in one table. This table has the following information:

- *module point number:* A1 - A8, B1 - B8, C1 - C8, D1 - D8, voltage and common points
- *connector pin number:* A1 through A12, and B1 through B12
- *cable pair number:* pair 1 through pair 12
- *wire color code:* base color or base color with tracer color

Columns are also provided for circuit references and customer wire numbers. Please copy and use the work sheets on this and the following page as needed when wiring the 5/24 Volt DC (TTL) Negative Logic, 32 Point Output module.

Wiring for Module Groups A and B (connector on right front of module)

Reference	Module Point Number	Connector Pin Number	Cable Pair Number	Wire Color Code	Wire Number
	A1	A1	1	Brown	
	A2	B1	7	Violet	
	A3	A2	1	Brown/Black	
	A4	B2	7	Violet/Black	
	A5	A3	2	Red	
	A6	B3	8	White	
	A7	A4	2	Red/Black	
	A8	B4	8	White/Black	
	A Common	A5	3	Orange	
	A Common	B5	9	Gray	
	AVIN	A6	3	Orange/Black	
	N/C	B6	9	Gray/Black	
	N/C	A7	4	Yellow	
	BVIN	B7	10	Pink	
	B Common	A8	4	Yellow/Black	
	B Common	B8	10	Pink/Black	
	B8	A9	5	Dark Green	
	B7	B9	11	Light Blue	
	B6	A10	5	Dark Green/Black	
	B5	B10	11	Light Blue/Black	
	B4	A11	6	Dark Blue	
	B3	B11	12	Light Green	
	B2	A12	6	Dark Blue/Black	
	B1	B12	12	Light Green/Black	

Wiring for Module Groups C and D (connector on left front of module)

Reference	Module Point Number	Connector Pin Number	Cable Pair Number	Wire Color Code	Wire Number
	C1	A1	1	Brown	
	C2	B1	7	Violet	
	C3	A2	1	Brown/Black	
	C4	B2	7	Violet/Black	
	C5	A3	2	Red	
	C6	B3	8	White	
	C7	A4	2	Red/Black	
	C8	B4	8	White/Black	
	C Common	A5	3	Orange	
	C Common	B5	9	Gray	
	CVIN	A6	3	Orange/Black	
	N/C	B6	9	Gray/Black	
	N/C	A7	4	Yellow	
	DVIN	B7	10	Pink	
	D Common	A8	4	Yellow/Black	
	D Common	B8	10	Pink/Black	
	D8	A9	5	Dark Green	
	D7	B9	11	Light Blue	
	D6	A10	5	Dark Green/Black	
	D5	B10	11	Light Blue/Black	
	D4	A11	6	Dark Blue	
	D3	B11	12	Light Green	
	D2	A12	6	Dark Blue/Black	
	D1	B12	12	Light Green/Black	

12/24 Volt DC, 0.5A Positive Logic Output, 32 Point IC693MDL753

The *12/24 volt DC, 0.5A Positive Logic Output* module for the Series 90-30 Programmable Logic Controller provides 32 discrete outputs. The outputs are arranged in four isolated groups of eight (A1 - A8, B1 - B8, C1 - C8, and D1 - D8); each group has its own common. The outputs are positive logic or sourcing type outputs in that they switch the loads on the positive side of the power supply, and therefore supply current to the load.

The outputs can switch user loads over the range of +12 through +24 VDC (+20%, -15%) and are capable of sourcing a maximum current of 0.5 amps per point. Two pins are provided on the user I/O connectors for each group common. Each pin has a current handling capability of 3 amperes. It is recommended that connections are made to both pins when connecting the common; however, it is a requirement for high current applications (between 3 and 4 amperes).

Each group can be used to drive different loads. For example, group A, B, and C can drive 24 VDC loads, while group D can be reserved for driving 12 VDC loads. Power to provide current to the loads must be provided by the user. The module also draws a minimum amount of power from the user supply to provide gate drive to the output devices.

Backplane isolation between the field side and logic side is provided by opto-couplers on the module.

All 32 outputs are forced OFF when the CPU is stopped. There are no special fault or alarm diagnostics reported. LED indicators (labeled A1 - A8, B1 - B8, C1 - C8, D1 - D8) at the top of the module provide the ON/OFF status of each output point.

This module is configured as a 32-point output type and uses 32 bits of discrete %Q output data. This module can be installed in any I/O slot of a 5 or 10-slot baseplate in a Series 90-30 PLC system.

Connections from the output circuits are made to the user load devices from two male (pin-type) 24-pin connectors (Fujitsu FCN-365P024-AU) mounted on the front of the module. The connector mounted on the right of the module (front view) interfaces with groups A and B. The connector on the left side of the module interfaces with groups C and D.

Wiring to Field Devices

- **Direct Method** – This method uses cables that have a mating female connector on the module end and stripped and tinned wires on the other end. You can purchase a pair of pre-wired cables, catalog numbers IC693CBL327 and IC693CBL328 or, if required for your application, build your own cables. Refer to *Building Cables for 24-Pin Connectors* in the IC693CBL327/328 data sheet in Appendix C of this manual for more information.
- **Using a TBQC** – The Terminal Block Quick Connect method uses a pair of cables with connectors on each end. These connect from the module connectors to connectors on DIN-rail mounted terminal blocks. The TBQC components are discussed in Appendix D.

Table 7-24. Specifications for IC693MDL753

Rated Voltage	12 through 24 volts DC, positive logic
Output Voltage Range	10.2 to 28.8 volts DC
Outputs per Module	32 (four groups of eight outputs each)
Isolation	1500 volts between field side and logic side 250 volts between groups
Output Current	0.5 amps per point with 4 amps maximum per group and 3 amps maximum per group common pin
Output Characteristics	
Inrush Current	5.4 amps for 10 ms
On-state Voltage Drop	0.3 volts DC
Off-state Leakage Current	0.1 mA maximum
On Response Time	0.5 ms maximum
Off Response Time	0.5 ms maximum
Internal Power Consumption	260 mA (maximum) from 5 volt bus on backplane; (13 mA + 3 mA/point ON + 4.7 mA/LED) 16.5 mA (maximum) per group from user supply @ 24 VDC and all eight outputs in group ON 9.6 mA (maximum) per group from user supply @ 12 VDC and all eight outputs in group ON

Refer to data sheet GFK-0867C, or later revision for product standards and general specifications.

TYPICAL CIRCUIT

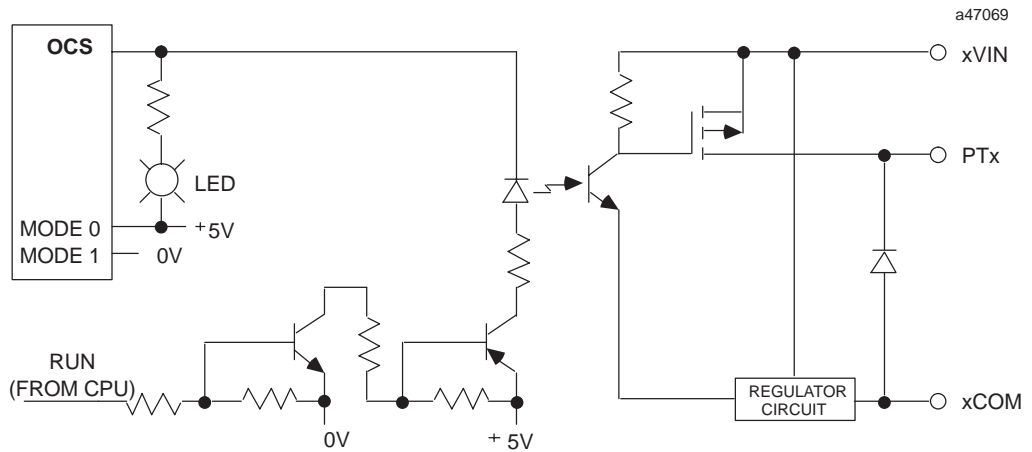

IC693MDL753 Output Module Field Wiring Information

The following figure provides wiring information for connecting user supplied load devices and power source to the 12/24 volt DC, 0.5A positive logic output module.

Module point numbers are shown in **bold text**.

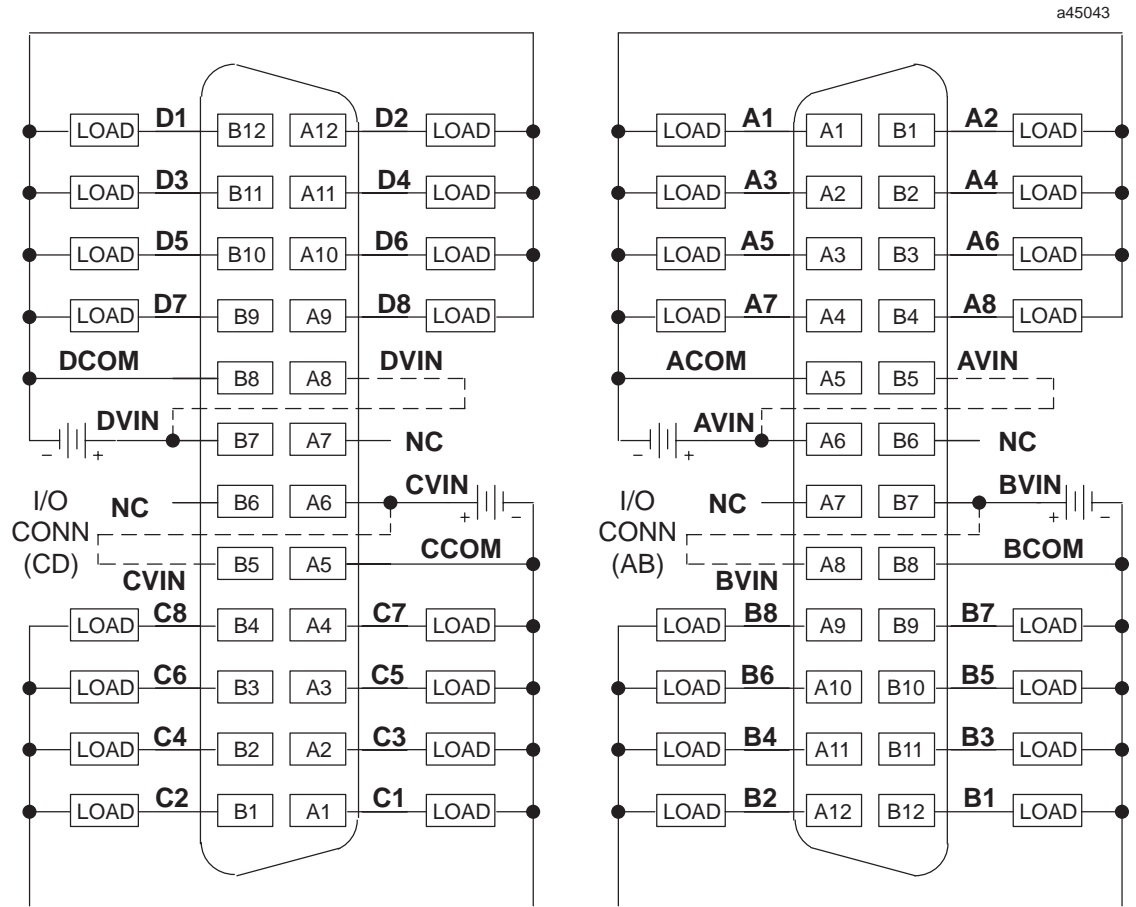

 = FUJITSU CONNECTOR PINS A1-A12, B1-B12 MODULE POINT NUMBERS ARE SHOWN IN **BOLD TEXT**.

NOTE: IF TOTAL LOAD CURRENT IS GREATER THAN 3A FOR A GROUP USE BOTH *VIN PINS (FOR APPLICABLE GROUP OR GROUPS) BY ADDING A SECOND WIRE AS SHOWN BY THE DASHED LINES.

Figure 7-41. Field Wiring - 12/24 Volt DC, 0.5A Positive Logic 32 Point Output Module - IC693MDL753

Field Wiring Work Sheet for IC693MDL753

The following table is provided for the convenience of our customers as an aid to wiring the 24-pin connectors using cable IC693CBL315. It includes all of the required wiring information in one table. This table has the following information:

- *module point number:* A1 - A8, B1 - B8, C1 - C8, D1 - D8, voltage and common points
- *connector pin number:* A1 through A12, and B1 through B12
- *cable pair number:* pair 1 through pair 12
- *wire color code:* base color or base color with tracer color

Columns are also provided for circuit references and customer wire numbers. Please copy and use the work sheets on this and the following page as needed when wiring the 12/24 Volt DC, 0.5A Positive Logic, 32 Point Output module.

Wiring for Module Groups A and B (connector on right front of module)

Reference	Module Point Number	Connector Pin Number	Cable Pair Number	Wire Color Code	Wire Number
	A1	A1	1	Brown	
	A2	B1	7	Violet	
	A3	A2	1	Brown/Black	
	A4	B2	7	Violet/Black	
	A5	A3	2	Red	
	A6	B3	8	White	
	A7	A4	2	Red/Black	
	A8	B4	8	White/Black	
	A Common	A5	3	Orange	
	AVIN	B5	9	Gray	
	AVIN	A6	3	Orange/Black	
	N/C	B6	9	Gray/Black	
	N/C	A7	4	Yellow	
	BVIN	B7	10	Pink	
	BVIN	A8	4	Yellow/Black	
	B Common	B8	10	Pink/Black	
	B8	A9	5	Dark Green	
	B7	B9	11	Light Blue	
	B6	A10	5	Dark Green/Black	
	B5	B10	11	Light Blue/Black	
	B4	A11	6	Dark Blue	
	B3	B11	12	Light Green	
	B2	A12	6	Dark Blue/Black	
	B1	B12	12	Light Green/Black	

Wiring for Module Groups C and D (connector on left front of module)

Reference	Module Point Number	Connector Pin Number	Cable Pair Number	Wire Color Code	Wire Number
	C1	A1	1	Brown	
	C2	B1	7	Violet	
	C3	A2	1	Brown/Black	
	C4	B2	7	Violet/Black	
	C5	A3	2	Red	
	C6	B3	8	White	
	C7	A4	2	Red/Black	
	C8	B4	8	White/Black	
	C Common	A5	3	Orange	
	CVIN	B5	9	Gray	
	CVIN	A6	3	Orange/Black	
	N/C	B6	9	Gray/Black	
	N/C	A7	4	Yellow	
	DVIN	B7	10	Pink	
	DVIN	A8	4	Yellow/Black	
	D Common	B8	10	Pink/Black	
	D8	A9	5	Dark Green	
	D7	B9	11	Light Blue	
	D6	A10	5	Dark Green/Black	
	D5	B10	11	Light Blue/Black	
	D4	A11	6	Dark Blue	
	D3	B11	12	Light Green	
	D2	A12	6	Dark Blue/Black	
	D1	B12	12	Light Green/Black	

Chapter 8

Discrete Combination I/O Modules

efesotomasyon.com

120 Volt AC Input, Relay Output, 8 Inputs/8 Outputs IC693MAR590

The *120 volt AC Input/Relay Output* module for the Series 90-30 Programmable Logic Controller provides 8 input points with one common power input terminal, and 8 normally-open relay circuits in the same module. The input circuits are reactive (resistor/capacitor) inputs and are arranged as one group of 8 inputs. The output points are arranged in two groups of four points each. Each group has a common power output terminal.

Input characteristics are compatible with a wide range of user-supplied devices, such as: pushbuttons, limit switches, and electronic proximity switches. Current through an input results in a logic 1 in the input status table (%I). Power to operate the field devices must be supplied by the user. This module's input section requires an AC power source, it cannot be used with a DC power source.

The normally-open relay circuits are used for controlling output loads provided by the user. The output switching capacity of each output is 2 amps. The relay outputs can control a wide range of user-supplied load devices, such as: motor starters, solenoids, and indicators. Power for the internal relay circuits is provided by the +24 volt DC bus on the backplane. The user must supply the AC or DC power to operate field devices. There are no fuses on this module.

LED indicators which provide the ON/OFF status of each point are located at the top of the module. The LEDs are arranged in two horizontal rows with eight green LEDs in each row. The top row is labeled A1 through 8 (input points 1 through 8) and the bottom row is labeled B1 through B8 (relay output points 1 through 8). An insert goes between the inside and outside surface of the hinged door. The surface towards the inside of the module (when the hinged door is closed) has circuit wiring information, and circuit identification information can be recorded on the outside surface. The outside left edge of the insert is color-coded red to indicate a high-voltage module.

This module can be installed in any I/O slot of a 5 or 10-slot baseplate in a Series 90-30 PLC system.

Table 8-1. Specifications for IC693MAR590

Inputs	
Rated Voltage	120 volts AC
Input Voltage range	0 to 132 volts AC
Inputs per Module	8 (one group of eight inputs)
Isolation	1500 volts RMS between field and logic side 500 volts RMS between inputs
Input Current	12 mA (typical) at rated voltage
Input Characteristics	
On-State Voltage	74 to 132 volts AC
Off-State Voltage	0 to 20 volts AC
On-State Current	6 mA (minimum)
Off-State Current	2.2 mA (maximum)
On Response Time	30 ms typical
Off Response Time	45 ms typical
Outputs	
Rated Voltage	24 VDC, 120/240 VAC
Operating Voltage	5 to 30 volts DC 5 to 250 volts AC, 50/60 Hz
Outputs per Module	8 (two groups of four outputs each)
Isolation	1500 volts RMS between field and logic side 500 volts RMS between groups
Maximum Load ‡	2 amps maximum per output 4 amps maximum per common
Minimum Load	10 mA
Maximum Inrush	5 amps
On Response Time	15 ms maximum
Off Response Time	15 ms maximum
Internal Power Consumption	80 mA (all I/O on) from +5V backplane bus 70 mA (all outputs on) from relay +24V backplane bus

‡ Maximum load current is dependent on operating voltage as shown in the following table.

Refer to Appendix B for product standards and general specifications.

Table 8-2. Load Current Limitations for IC693MAR590

Operating Voltage	Maximum Current for Load Type		Typical Contact Life (number of Operations)
	Resistive	Lamp or Solenoid †	
240 VAC, 120 VAC, 24 VDC	2 amps	.6 amps	200,000
240 VAC, 120 VAC, 24 VDC	1 amp	.3 amps	400,000
240 VAC, 120 VAC, 24 VDC	.5 amps	.1 amp	800,000

† For inductive loads

Relay contact life, when switching inductive loads, will approach resistive load contact life if suppression circuits are used. The following figures are examples of typical suppression circuits for AC and DC loads. The 1A, 100V diode shown in the DC load typical suppression circuit is an industry standard 1N4934. The resistor and capacitor shown for AC load suppression are standard components, available from most electronics distributors.

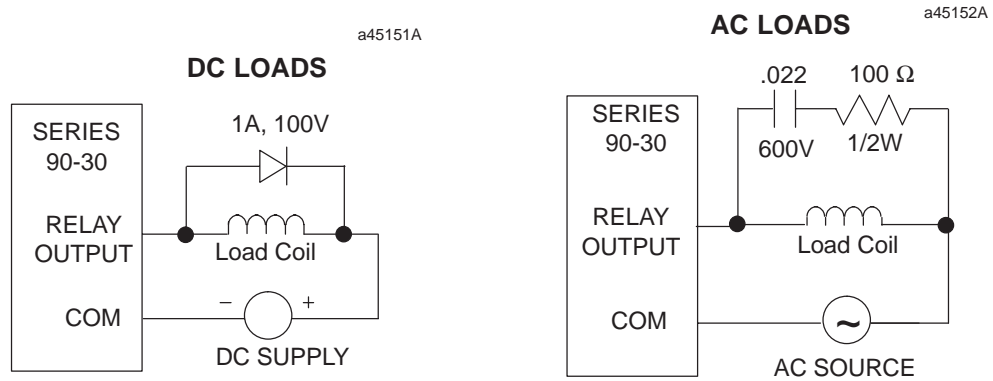

Field Wiring Information

The following figure provides wiring information for connecting user supplied input and load devices, and power source(s) to the 120 Volt Input/Relay Output module.

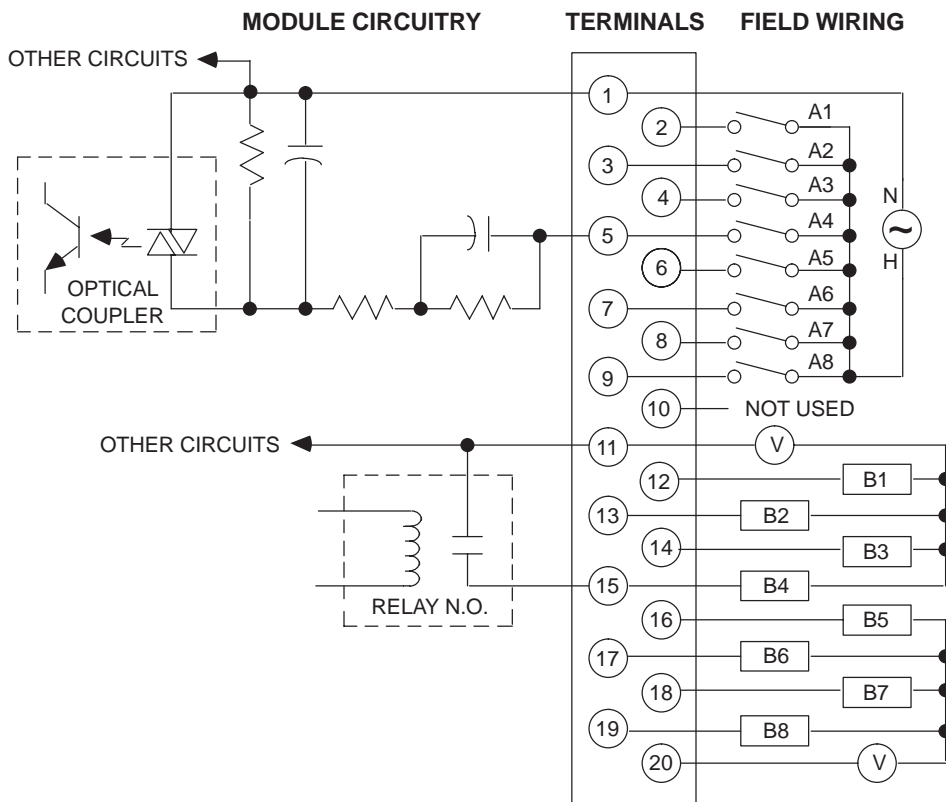

Figure 8-1. Field Wiring 120 VAC Input/Relay Output Module - IC693MAR590

24 Volt DC Input, Relay Output, 8 Inputs/8 Outputs IC693MDR390

The *24 volt DC Input/Relay Output* module for the Series 90-30 Programmable Logic Controller provides 8 input points with one common power input terminal, and 8 normally-open relay circuits in the same module. The input circuits are designed to have either positive or negative characteristics in that they sink or source current to/from the input devices to/from the user common and are arranged as one group of 8 inputs. The relay output circuits are arranged in two groups of four circuits each. Each group has a common power output terminal.

Input characteristics are compatible with a wide range of user-supplied devices, such as: pushbuttons, limit switches, and electronic proximity switches. Current through an input results in a logic 1 in the input status table (%I). Power to operate the field devices must be supplied by the user.

The normally-open relay circuits are used for controlling output loads provided by the user. The output switching capacity of each output is 2 amps. The relay outputs can control a wide range of user-supplied load devices, such as: motor starters, solenoids, and indicators. Power for the internal relay circuits is provided by the +24 volt DC bus on the backplane. The user must supply the AC or DC power to operate field devices. There are no fuses on this module.

LED indicators which provide the ON/OFF status of each point are located at the top of the module. The LEDs are arranged in two horizontal rows with eight green LEDs in each row. The top row is labeled A1 through 8 (input points 1 through 8) and the bottom row is labeled B1 through B8 (relay output points 1 through 8). An insert goes between the inside and outside surface of the hinged door. The surface towards the inside of the module (when the hinged door is closed) has circuit wiring information, and circuit identification information can be recorded on the outside surface. The top half of the outside left edge of the insert is color-coded blue to indicate low-voltage circuits and the bottom half of the outside left edge is color-coded red to indicate high-voltage circuits.

This module can be installed in any I/O slot of a 5 or 10-slot baseplate in a Series 90-30 PLC system.

Table 8-3. Specifications for IC693MDR390

Inputs	
Rated Voltage	24 volts DC
Input Voltage range	-30 to +32 volts DC
Inputs per Module	8 (one group of eight inputs)
Isolation	1500 volts RMS between field and logic side 500 volts RMS between inputs
Input Current	7.5 mA (typical) at rated voltage
Input Characteristics	
On-State Voltage	15 to 32 volts DC
Off-State Voltage	0 to +5 volts DC
On-State Current	4 mA (minimum)
Off-State Current	1.5 mA (maximum)
On Response Time	7 ms typical
Off Response Time	7 ms typical
Outputs	
Rated Voltage	24 VDC, 120/240 VAC
Operating Voltage	5 to 30 volts DC 5 to 250 volts AC, 50/60 Hz
Outputs per Module	8 (two groups of four outputs each)
Isolation	1500 volts RMS between field and logic side 500 volts RMS between groups
Maximum Load †	2 amps maximum per output 4 amps maximum per common
Minimum Load	10 mA
Maximum Inrush	5 amps
On Response Time	15 ms maximum
Off Response Time	15 ms maximum
Internal Power Consumption	80 mA (all I/O on) from +5V backplane bus 70 mA (all outputs on) from relay +24V backplane bus

† Maximum load current is dependent on operating voltage as shown in the following table.

Refer to Appendix B for product standards and general specifications.

Table 8-4. Load Current Limitations for IC693MDR390

Operating Voltage	Maximum Current for Load Type		Typical Operations (number of Operations)
	Resistive	Lamp or Solenoid †	
240 VAC, 120 VAC, 24 VDC	2 amps	.6 amps	200,000
240 VAC, 120 VAC, 24 VDC	1 amp	.3 amps	400,000
240 VAC, 120 VAC, 24 VDC	.5 amps	.1 amp	800,000

† For inductive loads

Relay contact life, when switching inductive loads, will approach resistive load contact life if suppression circuits are used. The following figures are examples of typical suppression circuits for AC and DC loads. The 1A, 100V diode shown in the DC load typical suppression circuit is an industry standard 1N4934. The resistor and capacitor shown for AC load suppression are standard components, available from most electronics distributors.

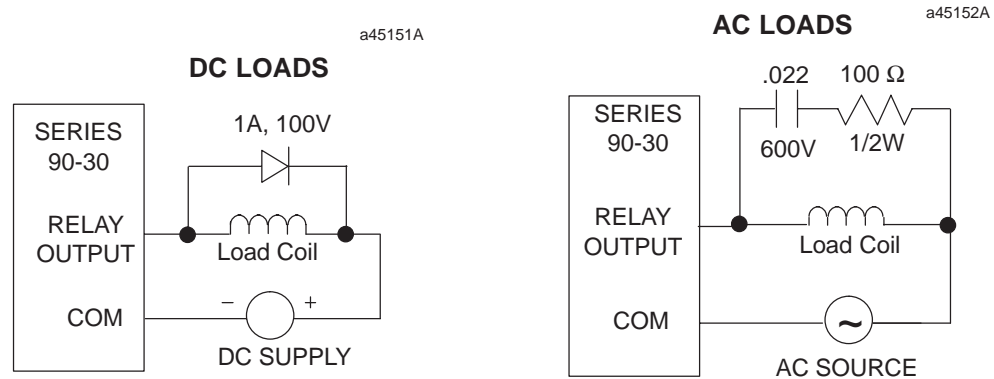

Field Wiring Information

The following figure provides wiring information for connecting user supplied input and load devices, and power source(s) to the 24 Volt Input/Relay Output module.

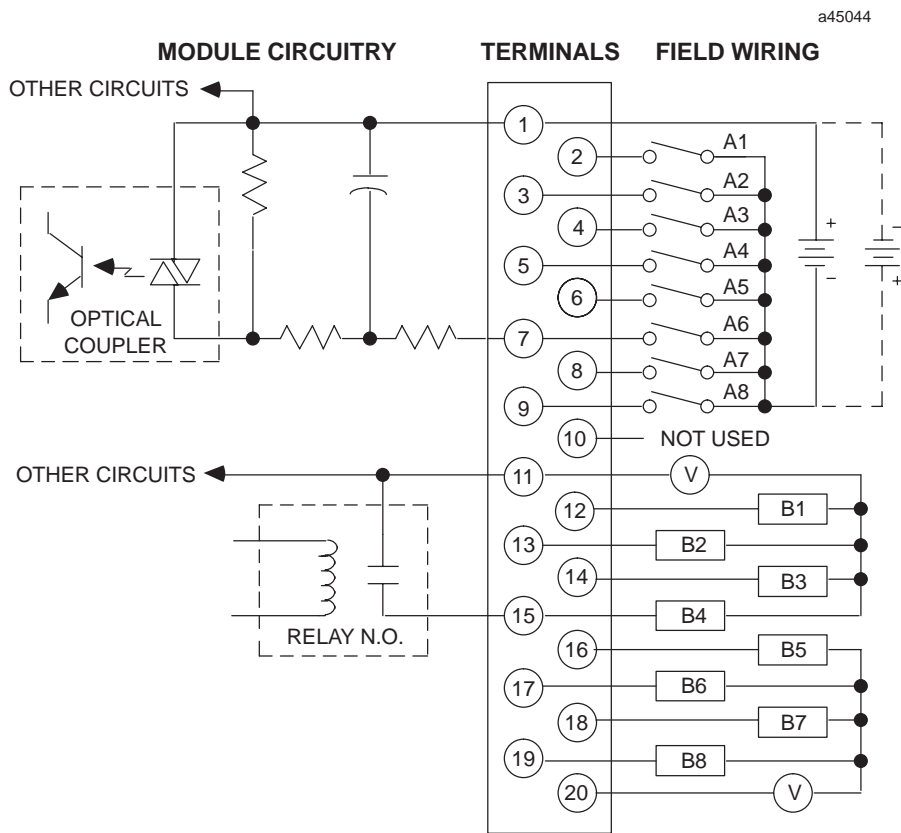

Figure 8-2. Field Wiring 24 VDC Input/Relay Output Module - IC693MDR390

Chapter 9

General Analog Module Information

efesotomasyon.com

This chapter describes the Analog Input and Output modules for the Series 90-30 Programmable Logic Controller. Module specifications and wiring information are provided for each of the available Analog I/O modules. The first part of this chapter describes how analog information is handled in the Series 90-30 PLC, followed by a description of each of the modules. Specific information for a particular analog module can be found in the description of that module.

Currently available Analog I/O modules are listed in the following table (Table 3-1) along with the chapter number where the description of each module can be found.

Guide to Chapter Location for Analog I/O Module Specifications

Catalog Number	Description of Module	Number of Channels	Chapter Number
IC693ALG220	Analog Input, Voltage	4 channel	Chapter 9
IC693ALG221	Analog Input, Current	4 channel	Chapter 9
IC693ALG222	Analog Input, Voltage (High-Density)	16 channel	Chapter 9
IC693ALG223	Analog Input, Current (High-Density)	16 channel	Chapter 9
IC693ALG390	Analog Output, Voltage	2 channel	Chapter 10
IC693ALG391	Analog Output, Current	2 channel	Chapter 10
IC693ALG392	Analog Output, Current/Voltage	8-channel	Chapter 10
IC693ALG442	Analog Combo Module, Current/Voltage	4 channels In 2 channels Out	Chapter 11

Analog Module Features

Analog Modules have the following basic features (refer to the following figure):

- **Removeable Terminal Board.** You can remove the terminal board from the module in order to wire it, if desired. Then, when you are finished wiring it, you can easily reinstall it on the module. However, some prefer to leave it on the module when wiring. If you ever need to replace a module, you don't have to do any rewiring if your old terminal board is still in good condition. Simply remove the wired terminal board from the old module and install it on the new module if it is good condition. The terminal board screw terminals are also convenient points for measuring voltages while testing or troubleshooting.
- **Hinged Front Cover.** The cover is easily opened to access the terminal board connections. For normal operation, it is kept closed to protect personnel from accidentally touching a hot terminal. Note in the following figure that the back side of the front cover insert contains a schematic diagram of the terminal board connections. The module catalog number (IC693ALG391 in this example) is printed on the bottom of the front cover insert. The module catalog number is also printed on the label on the side of the module. However, in order to see this side label, the module has to be removed from the PLC

On the front side of the front cover insert are lines that correspond to the module's I/O points. You can temporarily remove the insert and write the signal name for each point on the appropriate line to aid in testing or troubleshooting.

Also on the front side of the front cover insert, running vertically on the left edge of the insert, is a colored line that identifies the type of module: Blue = DC, Red = AC, and Gray = Analog.

- **Module Lens Cap.** Located on the top front of the module, it covers the LED (Light Emitting Diode) OK status light. This light indicates the basic status of the module. For normal operation, the OK LED should be on.

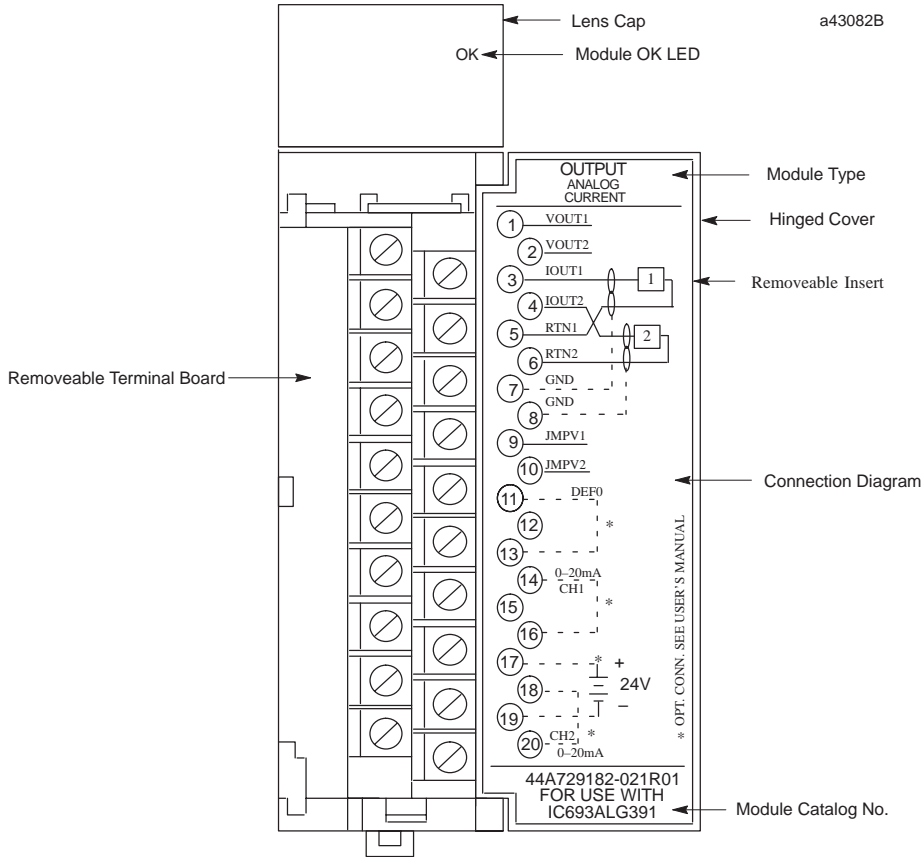

Figure 9-1. Example of Series 90-30 Analog Current Output Module

Load Requirements for Analog I/O Modules

The following table (Table 3-2) shows the DC load required by each Series 90-30 analog I/O module. All ratings are in milliamps. Input and Output module current ratings are with all inputs or outputs on. Note that the figures listed are maximum requirements, not typical. Load requirements for other Series 90-30 PLC components installed in a baseplate must be included in the total load calculations. Load requirements for all Series 90-30 PLC components can be found in GFK-0356, the *Series 90-30 Installation Manual*. Three voltages are listed in the table:

- +5 VDC provides primary power to operate most internal circuits
- +24 VDC Relay Power provides power for circuits that drive the relays on Relay output modules
- +24 VDC Isolated provides power to operate a number of input circuits (input modules only). This can also be used as the power input for some analog modules to power user-side circuitry

Table 9-1. Load Requirements (mA) for Analog I/O Modules

Catalog Number	Description	+5 VDC	+24 VDC Relay Power	+24 VDC Isolated
IC693ALG220	Analog Input, Voltage, 4 Channels	27 mA	-	98 mA
IC693ALG221	Analog Input, Current, 4 Channels	25 mA	-	100 mA
IC693ALG222	High-Density Analog Input, Voltage, 16 Channels	112 mA	-	41 mA
IC693ALG223	High-Density Analog Input, Current, 16 Channels	120 mA	-	†
IC693ALG390	Analog Output, Voltage, 2 Channels	32 mA	-	120 mA
IC693ALG391	Analog Output, Current, 2 Channels	30 mA	-	215 mA
IC693ALG392	High Density Analog Output, Current/Voltage, 8 Channels	110 mA	-	†
IC693ALG442	Analog Combo, Current/Voltage, 4 Ch In/2 Ch Out	95 mA	-	†

† Module analog power must be supplied by an external user supply. See individual module specifications for more information.

I/O Installation and Wiring

For information on installation, removal, and recommended wiring practices for Series 90-30 I/O modules, refer to Chapter 1.

Analog Terminology

There are several terms relating to measurements at analog I/O terminals that you should be familiar with. Refer to Appendix A for a list of these terms and their definitions. Additionally, the following pages describe how analog information is handled in the Series 90-30 PLC. Specific information for individual modules can be found in the description of that module.

Hardware Description of Analog Modules

Analog modules provide inputs and outputs with continuous values, as compared with digital input and output modules which have discrete values of ON or OFF. Analog modules convert digital words to analog signals, or analog signals to digital words, depending on whether the module is an output module or an input module.

Differential Inputs

The %AI data table is a storage location within the Series 90-30 CPU where the input information is stored. The Series 90-30 PLC has current and voltage analog input modules available; however, the Series 90-30 CPU does not recognize a difference between the two types of analog modules.

The Series 90-30 PLC system must be configured by the user as described in the *Series 90-30 Programmable Controller Installation Manual*, GFK-0356 and the *Logicmaster 90-30/20/Micro Programming Software User's Manual*, GFK-0467. After configuration, the four analog input channels will correspond to 64 bits in the data table (256 bits for the high-density 16 channel analog input modules).

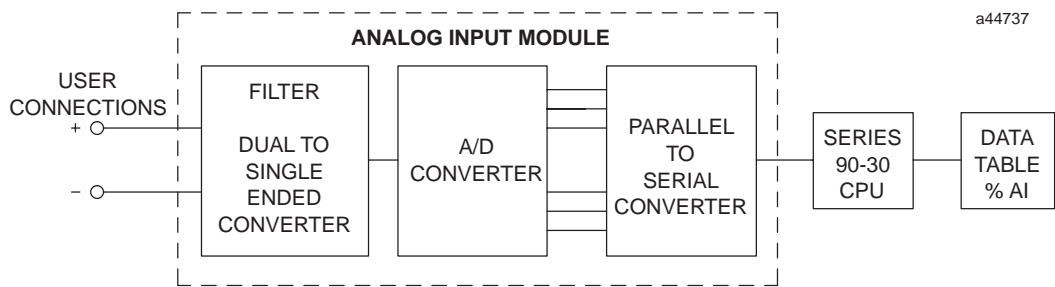

Figure 9-2. Analog Input Block Diagram

The analog inputs are differential; that is, the converted data is the difference between the voltages IN+ and IN- as shown in Figure 3-2. The differential input configuration is much less sensitive to noise and ground currents. Both inputs are referenced to a common voltage, referred to as COM. The average voltage of the IN terminals with respect to COM is referred to as *Common Mode Voltage*. Different signal sources may have different common mode voltages, shown as V (CM1) and V (CM2). This common mode voltage may be caused by differences in location of circuit grounds, or by the nature of the input signal itself.

To reference floating sources and limit common mode voltages, the COM terminal should be connected to either side of the input at the source itself. Without special design considerations, the summation of the common mode voltage, the differential input voltage and noise on the lines referenced to the COM terminals is limited to ±11 volts, or damage may result to the module. The input modules provide some filtering to protect against high frequency spikes, but low frequency signals exceeding this will produce erroneous conversions.

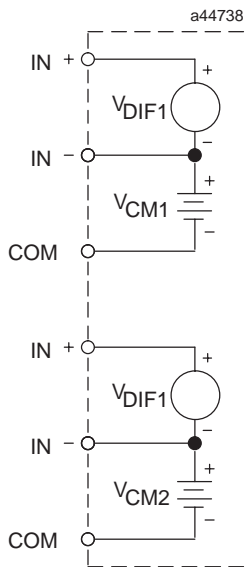

Figure 9-3. Analog Input Common Mode Voltage

Outputs

The %AQ data table is a memory location within the Series 90-30 CPU where the output information is stored. Both current and voltage analog output modules are available for the Series 90-30 PLC; however, the Series 90-30 CPU does not recognize the difference between the two types of analog outputs. The user must configure the Series 90-30 PLC system as described in the *Series 90-30 Programmable Controller Installation Manual*, GFK-0356 and the *Logi-master 90 Series 90-30/20/Micro Programming Software User's Manual*, GFK-0466. After configuration, the two analog outputs will correspond to 32 bits in the data table.

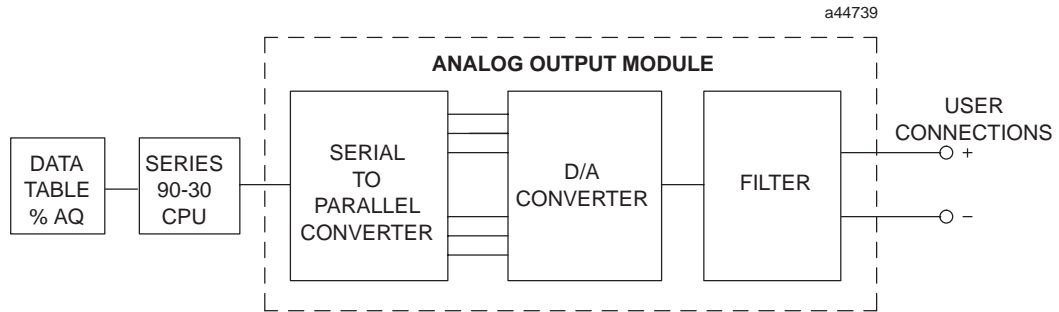

Figure 9-4. Analog Output Block Diagram

CPU Interface to Analog Modules

The Series 90-30 PLC uses the data within the %AQ and %AI data tables to drive or record analog values as shown in Figures 3-1 and 3-3. The analog data is handled in a 2's complement format. Two's complement, for conversion purposes, consists of a binary code for positive magnitudes (represented by a 0 (zero) in the most significant bit), and the 2's complement of each positive number to represent its negative. To convert negative numbers from 2's complement to binary, invert each bit and add one. The operation below is an example conversion of a 16-bit word.

2's Complement	Binary
11001011101010000	0011010010101111
	+ <u>1</u>
	- 0011010010110000

Working in decimal format, instead of hexadecimal, within the data tables will allow easier calculations when you are working with analog data. You can use the data in the %AQ and %AI data tables for any math or data function without having to do any conversion or 2's complement math. When using raw data in any math calculations, you would usually use double precision math.

You can find corresponding data words and analog values for programming purposes by using the following equations and the values in Table 3-3.

$$\text{Data Word} = \frac{(\text{Analog Value} - \text{Offset}) \times 2^n}{\text{Resolution}^1}$$

$$\text{Analog Value} = \frac{\text{Data Word} \times \text{Resolution}^1 + \text{Offset}}{2^n}$$

¹ analog value/bit; ⁿ = number of disregarded LSBs

Table 9-2. Equation Values for Analog Modules

Module	Disregarded LSB	Offset	Analog Range	Resolution	Resolution Per Bit
Analog Voltage Output	3	0V	20V	13 bits	2.5 mV/bit
Analog Current Output					
4 to 20 mA Range	3	4 mA	16 mA	12 bits	4 µA/bit
0 to 20 mA Range	3	0 mA	20 mA	12 bits	5 µA/bit
Analog Voltage Input	4	0 V	20 V	12 bits	5 mV/bit
Analog Current Input					
4 to 20 mA Range	3	4 mA	16 mA	12 bits	4 µA/bit
0 to 20 mA Range	3	0 mA	20 mA	12 bits	5 µA/bit
Analog Current Input 16-Channel					
4 to 20 mA Range	3	4 mA	16 mA	12 bits	4 µA/bit
0 to 20 mA Range	3	0 mA	20 mA	12 bits	5 µA/bit
4 to 20 mA Range Enhanced	n/a	4 mA	20 mA	12 bits	5 µA/bit
Analog Voltage Input 16-Channel					
0 to +10V Range	3	0 V	10 V	12 bits	2.5 mV/bit
-10 to +10V Range	4	0 V	20 V	12 bits	5 mV/bit
Analog Current/Voltage Output 8-Channel					
0 to +10V Range	n/a	0 V	10 V	15 bits	2.5 mV/bit
-10 to +10V Range	n/a	0 V	20 V	16 bits	5 mV/bit
4 to 20 mA Range	n/a	4 mA	16 mA	15 bits	4 µA/bit
0 to 20 mA Range	n/a	0 mA	20 mA	15 bits	5 µA/bit

Example 1: if you want a 12 mA setpoint for a current input (4 - 20 mA range) for the 16-Channel Current Input module (IC693ALG223) use the first equation to find the corresponding data word as shown below.

$$\text{Data Word} = \frac{(12 \text{ mA} - 4 \text{ mA}) \times 2^3}{4 \text{ } \mu\text{A}} = 16000$$

Example 2: if you want a 5V setpoint for a voltage input (0 to +10V range) for the 16-Channel Voltage Input module (IC693ALG222) use the first equation to find the corresponding data word as shown below.

$$\text{Data Word} = \frac{5\text{V}}{2.5 \text{ mV}} \times 2^3 = 16000$$

Example 3: if you want a 5 volt setpoint for a 4-Channel Voltage Input module (IC693ALG220), use the first equation to find the corresponding data word as shown below.

$$\text{Data Word} = \frac{(5V - 0V) \times 2^4}{5 \text{ mV}} = 16000$$

Placement of A/D and D/A Bits within the Data Tables

Since converters used in the analog modules are 13-bit converters, not all of the 16 bits in the data tables contain data required for the conversion. A version of the 12 bits is placed within the 16-bit data word corresponding to the analog point (in %AQ or %AI tables). The Series 90-30 system handles the integration differently for the various analog modules.

The Series 90-30 system disregards the data placed in the extra bits in the %AQ table and uses those bits for communications with the module. The CPU also converts the data in the %AQ data word from 2's complement to sign magnitude format before sending the data to the output module. The CPU does not manipulate the data from the input modules before placing it within the word in the %AI data table. The bits in the %AI data table which were not used in the conversion by the input module are forced to 0 (zero) by the analog input module. An example of the bit placement for an analog current output data word is shown below. This example is for the Analog Current output module, catalog number IC693ALG391.

MSB												LSB			
S	D11	D10	D9	D8	D7	D6	D5	D4	D3	D2	D1	D0	X	X	X

S=sign bit
X=not converter bits

Analog values are scaled over the range of the converter. Factory calibration adjusts the analog value per bit (resolution) to a multiple of full scale (that is, 4 microamps/bit). This calibration leaves a normal 12-bit converter with 4000 counts (normally $2^{12} = 4096$ counts). The data is then scaled with the 4000 counts over the analog range. For example, the data to the D/A converter for the analog current output is scaled as shown in Figure 3-4.

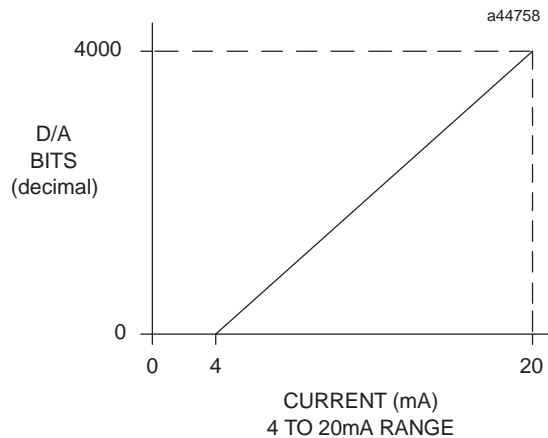

Figure 9-5. D/A Bits vs. Current Output for IC693ALG391

More detailed information on placement and scaling for the analog modules can be found within their respective specifications.

Stair Step Effect of Output

Because the converted bits (12 bits) in the data word (16 bits) are not right-justified, the placement of the converted bits causes the output, or input, to be a stair step. The net effect of the stair step for an output module is that not every increase in the %AQ data table will cause an increase in the output. The net effect for an input module is that an increased input will not cause the LSB (Least Significant Bit) of the data word in the %AI table to change. The size of the step depends on the range of the analog signal, the resolution of the conversion, and the number of LSBs disregarded. These factors can be used to calculate the size of the step. For example, the analog output module provides outputs from 4 to 20 mA in 12 bits. Therefore, each bit represents $(20-4 \text{ mA})/2^{12} \text{ bits} = 3.906 \text{ } \mu\text{A/bit}$. However, factory calibration adjusts for an even number of microamps per bit ($4 \text{ } \mu\text{A/bit}$). Since the three LSBs in the %AQ output are not used in the conversion, an 8 count (2^3) increase in the %AQ output is needed to change the analog output by $4 \text{ } \mu\text{A}$. The software rounding algorithm causes the step to rotate between a count of 7 and a count of 9 instead of 8. The values supplied in Table 3-3 provide you with the information needed to calculate step sizes.

The following figure shows a portion of the analog current output versus the corresponding data word in %AQ.

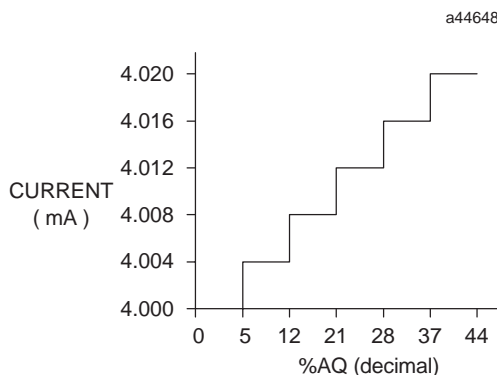

Figure 9-6. Stair Step Effect on Analog Values

Although the analog signals are stair step, they can be approximated with a linear graph. The following figures show the relationship between voltage and current in the %AQ and %AI data words.

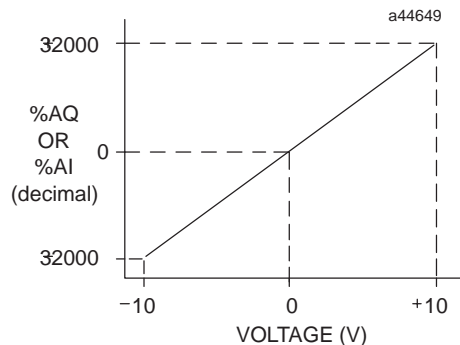

Figure 9-7. Voltage vs. Data Word

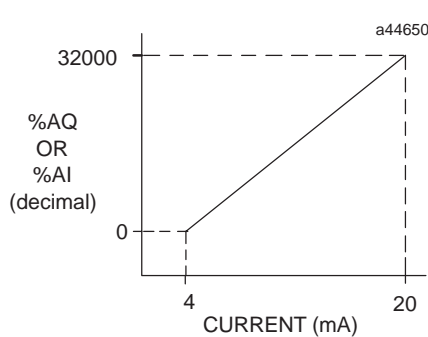

Figure 9-8. Current vs. Data Word

Scaling

The data may be changed to a scale more suited to your application. This may be accomplished through programming with Logicmaster 90-30/20/Micro software. The formula for the data conversion is shown below.

$$\frac{\text{Data Word (\%AQ or \%AI)}}{32000} = \frac{\text{Application Data Value} - \text{Application Offset}}{\text{Application Maximum Value} - \text{Application Minimum Value}}$$

For analog inputs, the application data value is what you will need to calculate for based on the analog data word. For analog outputs, the analog data word is what you will need to calculate for based on the application data value and maximum range. An example of scaling is a 0 to 10 volt signal that actually represents 0 to 2000 rpm. For an output signal, the following factor would be used.

$$\frac{\text{Data Word}}{32000} = \frac{\text{Xrpm} - 0}{2000 \text{ rpm} - 0 \text{ rpm}}$$

Solving the above equation,

scaling an input in a program: $X_{\text{rpm}} = \%AI \div 16.$

scaling an output in a program as: $\%AQ = X_{\text{rpm}} \times 16.$

Another example would be a 1 to 5 volt signal which actually represents 4 to 20 mA. If you want to use values in your program that are actually mA values, use the following equation for calculating scaling factors.

$$\frac{\text{Data Word}}{32000} = \frac{\text{XmA} - 4 \text{ mA}}{20\text{mA} - 4 \text{ mA}}$$

Solving the above equation,

scaling an input in a program: $X_{\text{mA}} = (\%AI \div 2000) + 4$

scaling an output in a program: $\%AQ = (X_{\text{mA}} \times 2000) - 8000$

With the placement and scaling known, you can modify the data from the %AI table or the data to the %AQ table by the scale factor to satisfy your application needs.

Performance Measures

The performance of analog modules can be measured by resolution, accuracy, linearity, and cross-channel rejection. Resolution of the module is the weight assigned to the least significant bit in the conversion process. For example, 4 μA/bit is the resolution of the analog current output module. A module with 8 μA/bit has half the resolution of the analog current output module. The resolution of a module is determined by the converter used in the analog module. The accuracy of the module is dependent upon the tolerances of components used in the module's circuitry. Accuracy is the maximum difference between the expected and measured values. Linearity is the difference between the measured change and the ideal one LSB change between any two adjacent channels. Cross-channel rejection is the influence on one channel when the input to another channel is changed.

Analog Module Field Wiring

Connections to an analog module from user field devices are made to screw terminals on a removable 20-terminal connector block mounted on the front of the module. Information on field wiring for analog modules can be found in two basic places in this manual:

- Chapter 2, “General Installation Guidelines.” Contains such information as mounting, wiring, and noise suppression methods.
- Details specific to individual modules, such as terminal pin-out information, are shown in the analog module data sheets, which are found in Chapters 10, 11, and 12.

Maximum Number of Analog Modules per System

The maximum number of modules installed in a system depends on several factors, including available references for each CPU model, current consumption for each module to be installed, slots available in baseplate(s), selectable configuration parameters and, where applicable, whether Isolated +24 VDC is supplied by the PLC backplane or by a user provided supply. Before installing modules in a baseplate, verify that the total current consumption of all of those modules does not exceed the power rating of the Series 90-30 power supply (30 watts maximum, all voltages). The following tables will help you determine the maximum number of analog I/O modules that can be installed in a Series 90-30 PLC system. *Calculations assume maximum number of references used. Modules with selectable references can have more modules per system.*

Table 9-3. User Reference and Current (mA) Requirements

Analog Module	%AI References (maximum)	%AQ References (maximum)	%I References	Current from +5 VDC †	Current from Isolated +24 VDC †
IC693ALG220	4	–	–	27	98
IC693ALG221	4	–	–	25	100
IC693ALG222	16	–	8 to 40	112	41
IC693ALG223	16	–	8 to 40	120	<i>user supplied</i>
IC693ALG390	–	2	–	32	120 ‡
IC693ALG391	–	2	–	30	215 ‡
IC693ALG392	–	8	8 or 16	110	<i>user supplied</i>
IC693ALG442	4	2	8, 16, or 24	95	<i>user supplied</i>

† Maximum current available from Standard AC/DC and DC power supply: +5 VDC = 15W (3000 mA); Isolated +24 VDC = 20W (830 mA). High Capacity AC/DC and DC power supplies provide 30W (6000 mA) for +5 VDC; Isolated +24 VDC = 20W (830 mA). *For all supplies – maximum total power for all outputs cannot exceed 30 watts.*

‡ Supplied from Isolated +24 VDC on backplane, or from user supply.

Table 9-4. User References Available per System

CPU Model	%AI	%AQ	%I
311, 313, and 323	64 words	32 words	512
331	128 words	64 words	512
340 and 341	1024 words	256 words	512
350	2048 words	512 words	2048
351 – 364	128 – 32640 words, configurable	128 – 32640 words, configurable	2048

Table 9-5. Maximum Number of Analog Modules per System

Analog Module Type	CPU Models 311/313/323 ¹	CPU Models 350 – 364 ¹
IC693ALG220 and IC693ALG221 Input Module, 4-Channel	5 (5-slot baseplate, Model 311/313) 8 (10-slot baseplate, Model 323)	40 (Model 331/340/341) 64 (Model 350 – 364)
IC693ALG222 and IC693ALG223 Input Module, 16-Channel	4 (5-slot baseplate, Model 311/313) 4 (10-slot baseplate, Model 323)	8 (Model 331) 12 (Model 340/341) 51 (Model 350 – 364)
IC693ALG390 Voltage Output Module, 2-Channel	5 (5-slot baseplate, Model 311/313) 6 (10-slot baseplate, Model 323)	16 (Model 331) 30 (Model 340/341) 48 (Model 350 – 364)
IC693ALG391 Current Output Module, 2-Channel	3 (5-slot baseplate, Model 311/313) 3 (10-slot baseplate, Model 323)	15 (Model 331) ² 15 (Model 340/341) ² 24 (Model 350 – 364) ²
IC693ALG392 Output Module, 8-Channel	4 (5-slot baseplate, Model 311/313) 4 (10-slot baseplate, Model 323)	8 (Model 331) 32 (Model 340/341) 64 (Model 350 – 364)
IC693ALG442 Combination Input/Output Module, 4-Ch In/2-Ch Out	5 (5-slot baseplate, Model 311/313) 10 (10-slot baseplate, Model 323)	21 (Model 331/340/341) 79 (Model 350 – 364)

¹ Maximum I/O slots available per system; Model 311/313 (5), Model 323 (10), Model 331/340/341 (49), Model 350 – 364 (79).

² More if +24 VDC is user supplied (32 for Model 331, 49 for Model 340/341, 79 for Model 350 – 364).

Chapter 10

Analog Input Modules

efesotomasyon.com

Analog Voltage Input - 4 Channel IC693ALG220

The *4-Channel Analog Voltage Input* module for the Series 90-30 Programmable Logic Controller provides four input channels, each capable of converting an analog input signal to a digital signal for use as required by your application. The Analog Voltage Input module is capable of converting inputs in the range of -10 to $+10$ volts. Conversion speed for each of the four channels is one millisecond. This provides an update rate of four milliseconds for any channel. Resolution of the converted signal is 12 bits binary (1 part in 4096).

User data in the %AI registers is in 16-bit 2's complement format. The placement of the 12 bits from the A/D converter in the %AI data word is shown below. The relationship between the voltage input and the data from the A/D converter is shown in Figure 3-10.

MSB												LSB			
S	D10	D9	D8	D7	D6	D5	D4	D3	D2	D1	D0	X	X	X	X

X = not applicable to this discussion.
S = sign bit

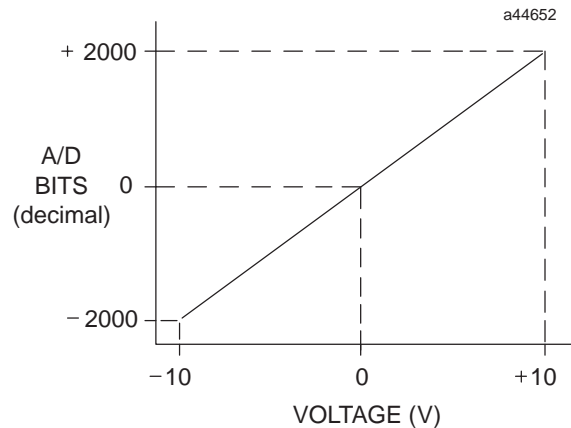

Figure 10-1. A/D Bits vs. Voltage Input

Scaling of the input is shown below in Figure 3-11.

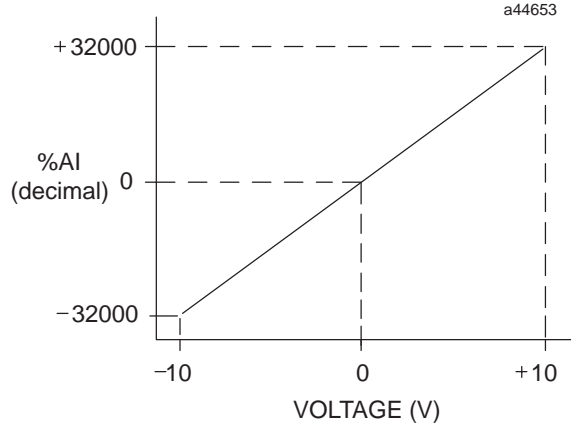

Figure 10-2. Scaling for Voltage Input

A limited current input mode is also provided in the module. A jumper is provided on the user terminal connector for each channel, which may be used to connect the internal 250 ohm shunt resistor into the circuit. The shunt resistor effectively provides a -40 to $+40$ mA current input range. However, the input current should generally not exceed ± 20 mA, to avoid self-heating of the input resistor and a corresponding loss of accuracy. A 4 to 20 mA input corresponds to a 1 to 5 volt input to the voltage input module; therefore, the resolution of the 4 to 20 mA input signal is approximately 10 bits binary (1 part in 1024). The resolution can be increased to approximately 11 bits (1 part in 2048) by using a precision 250 ohm resistor in place of the jumper. The resistor causes the voltage input module to see a 4 to 20 mA input as 2 to 10 volts.

The main power source for the module is derived from the isolated +24 VDC power supplied by the PLC power supply. This voltage is routed through an inverter/regulator to produce the operating voltages for the module. This module also consumes 27 mA from the +5 VDC output of the PLC power supply. An LED at the top of the module's faceplate is ON when the module's power supply is operating. The module provides electrical isolation of externally generated noise between the field wiring and the backplane through optical isolation.

To minimize the capacitive loading and noise, all field connections to the module should be wired using a good grade of twisted, shielded instrumentation cable. The shields can be connected to either COM or GND. The COM connection provides access to the common of the analog circuitry in the module. The GND connection provides access to the baseplate (frame ground).

This module can be installed in any I/O slot of a 5 or 10-slot baseplate in a Series 90-30 PLC system. See page 3-11 to determine the number of Analog Voltage Input modules that can be installed in a system.

Note

Connect the + and - terminals together for all unused inputs in order to minimize any fluctuations in the analog input table for the unused points.

Table 10-1. Specifications for Analog Voltage Input Module - IC693ALG220

Voltage Range	-10 to +10 volts †
Calibration	Factory calibrated
Update Rate	4 msec (all four channels)
Resolution	5 mV/20 µA, (1 LSB = 5 mV)
Absolute Accuracy ‡	±10 mV/40 µA (typical) over operating temperature ±30 mV/160 µA (maximum) over operating temperature
Linearity	< 1 Least Significant Bit
Isolation	1500 volts between field side and logic side
Cross-Channel Rejection	> 80 db
Input Impedance	> 9 Megohms (voltage mode) 250 ohms (current mode)
Input Filter Response	17 Hz
Internal Power Consumption	27 mA from +5 volt bus on the backplane 98 mA from the isolated +24 volt backplane bus

Refer to Appendix C for product standards and general specifications.

† Both inputs must be within ± 11 volts of COM, including any noise present on the inputs.

‡ In the presence of severe RF interference (IEC 801-3, 10V/m), accuracy may be degraded to ±100 mV/400 µA.

Analog Voltage Input Block Diagram

The following figure is a block diagram of the 4-Channel Analog Voltage Input Module.

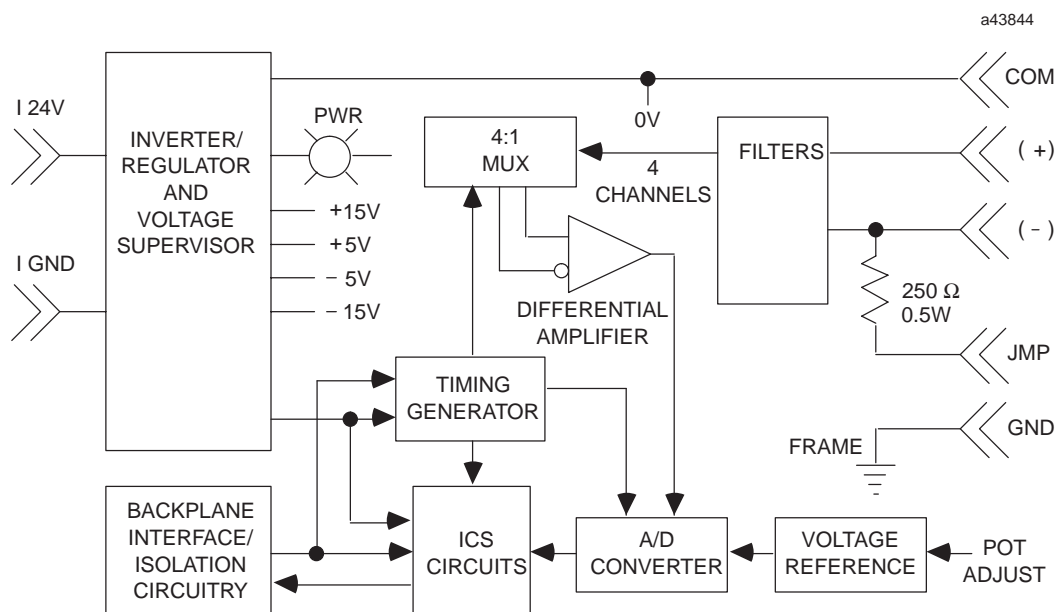

Figure 10-3. Analog Voltage Input Module Block Diagram for IC693ALG220

IC693ALG220 Analog Input Module Field Wiring Information

The following figure provides information for connecting field wiring to the 4-Channel Analog Voltage Input module.

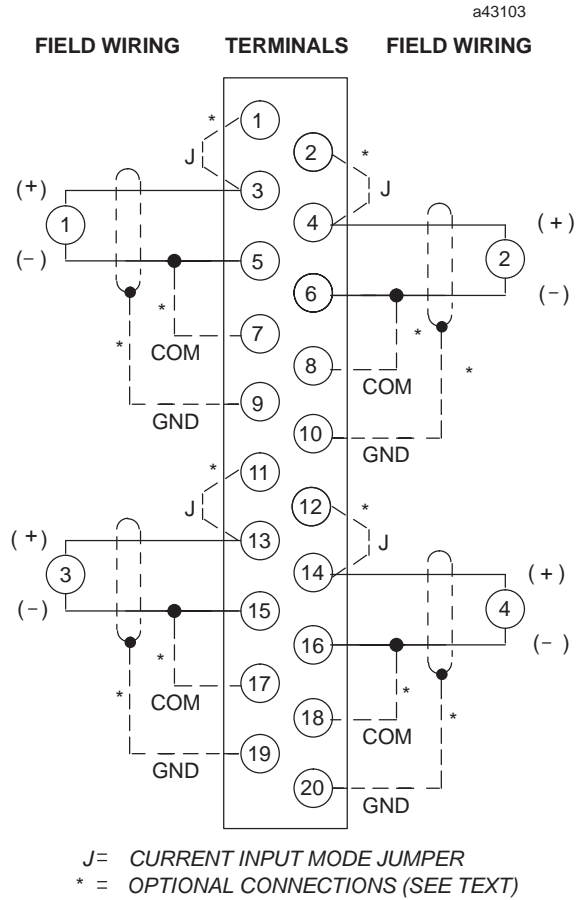

Figure 10-4. Field Wiring for 4-Channel Analog Voltage Input Module

Note

The (-) side of the voltage source can also be tied to the COM terminal if the source is floating to limit common-mode voltages. The COM connection provides access to the common of the analog circuitry in the module. The GND connection provides access to the baseplate (frame ground).

Please refer to Chapter 2 for wiring and shield ground connection details.

Analog Current Input - 4 Channel IC693ALG221

The **4-Channel Analog Current Input module** for the Series 90-30 Programmable Logic Controller provides four input channels, each capable of converting an analog input signal to a digital signal for use as required by your application. This module provides two input ranges. The default range is 4 to 20 mA with user data scaled so that 4 mA corresponds to a count of 0 and 20 mA corresponds to a count of 32000 with each 1000 counts representing 0.5 mA. When a jumper is added to the I/O terminal board, the input range is changed to 0 to 20 mA with user data scaled so that 0 mA corresponds to a count of 0 and 20 mA corresponds to a count of 32000 with each 800 counts representing 0.5 mA. Two range jumpers are provided with the module; one for channels one and two, and the other for channels three and four.

Conversion speed for each of the four channels is one-half millisecond. This provides an update rate of two milliseconds for any channel. Resolution of the converted signal is 12 bits binary (1 part in 4096) over either range. User data in the %AI registers is in 16-bit 2's complement format. The placement of the 12 bits from the A/D converter in the %AI data word is shown below. The relationship between the current input and the data from the A/D converter is shown in Figures 3-14 and 3-15.

MSB												LSB			
X	D11	D10	D9	D8	D7	D6	D5	D4	D3	D2	D1	D0	X	X	X

X=not applicable to this discussion.

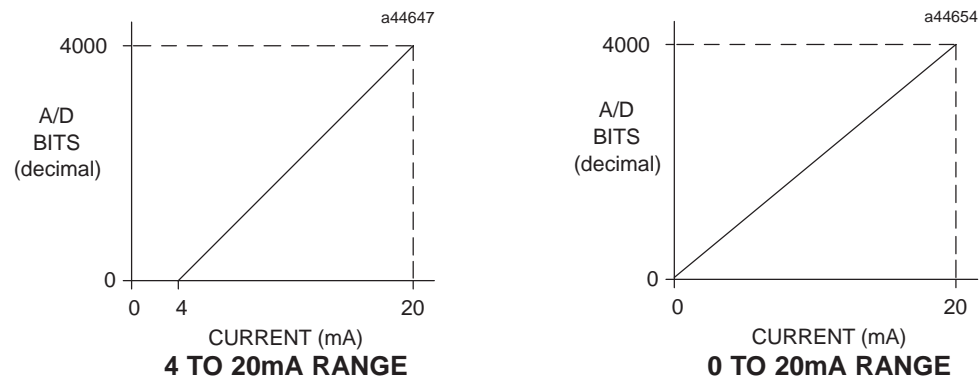

Figure 10-5. A/D Bits vs. Current Input

If the current source is reversed into the input, or is less than the low end of the current range, then the module will output a data word corresponding to the low end of the current range (0000H in %AI). If an input that is out of range is entered (that is, it is greater than 20 mA), the A/D converter will output up to full scale (corresponding to 7FF8H in %AI).

Input scaling is shown in the next figure.

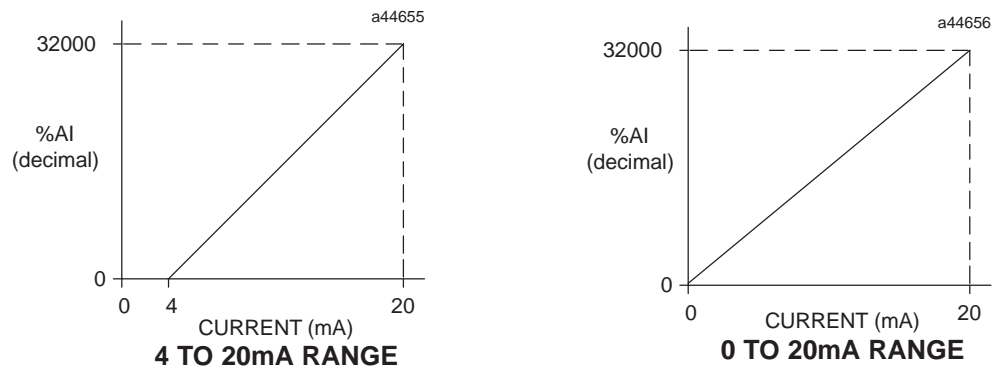

Figure 10-6. Scaling for Analog Current Input

Input protection for the module is sufficient to guarantee operation with reduced performance with up to 200V common-mode. The module provides electrical isolation of externally generated noise between field wiring and the backplane through the use of optical isolation.

To minimize the capacitive loading and noise, all field connections to the module should be wired using a good grade of twisted, shielded instrumentation cable. The shields can be connected to either COM or GND. The COM connection provides access to the common of the analog circuitry in the module. The GND connection provides access to the baseplate (frame ground).

An LED at the top of the faceplate is ON when the module’s power supply is operating. The main power source for the module is the isolated +24 VDC power supplied by the PLC power supply. This voltage is routed through an inverter/regulator to provide the operating voltage for the module. This module also consumes power from the +5 VDC output of the PLC power supply to drive the isolation circuitry. This module can be installed in any I/O slot of a 5 or 10-slot baseplate in a Series 90-30 PLC system. See page 3-11 to determine the number of Analog Current Input modules that can be installed in a system.

Table 10-2. Specifications for Analog Current Input Module - IC693ALG221

Input Current Ranges	4 to 20 mA and 0 to 20 mA
Calibration	Factory calibrated to 4 μ A per count
Update Rate	2 msec (all four channels)
Resolution at 4-20 mA	4 μ A (1 LSB = 4 μ A)
Resolution at 0-20 mA	5 μ A (1 LSB = 5 μ A)
Absolute Accuracy †	0.1% full scale + 0.1% reading
Common Mode Voltage	200 volts
Linearity	< 1 Least Significant Bit
Isolation	1500 volts between field side and logic side
Common Mode Rejection	> 70 db at DC; >70 db at 60 Hz
Cross-Channel Rejection	> 80 db from DC to 1 kHz
Input Impedance	250 ohms
Input Filter Response	325 Hz
Internal Power Consumption	100 mA from the isolated +24 volt supply 25 mA from +5 volt bus on the backplane

Refer to Appendix B for product standards and general specifications.

† In the presence of severe RF interference (IEC 801-3, 10V/m), accuracy may be degraded to $\pm 0.5\%$ FS.

IC693ALG221 Analog Current Input Block Diagram

The following figure is a block diagram of the 4-Channel Analog Current Input Module.

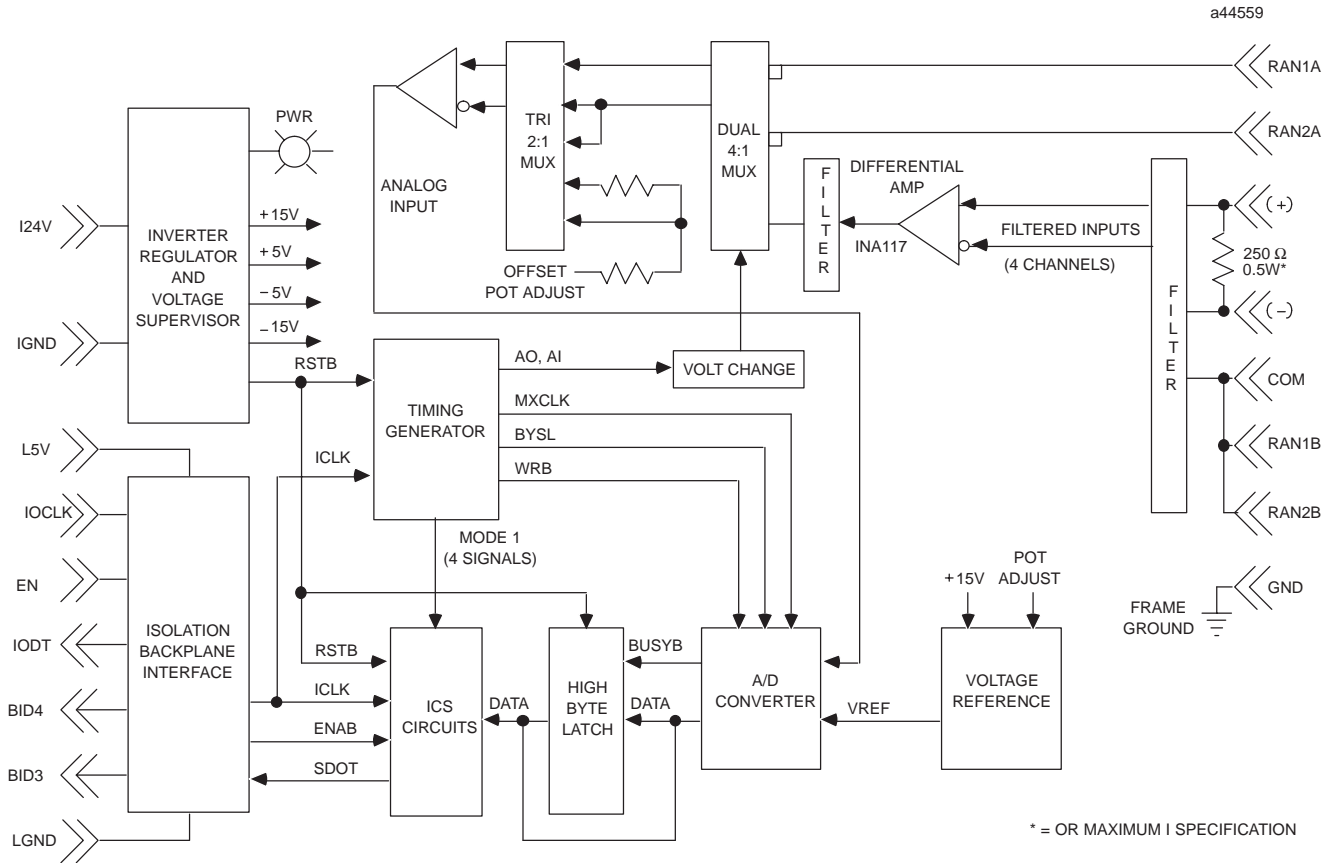

Figure 10-7. Analog Current Input Module Block Diagram - IC693ALG221

IC693ALG221 Analog Input Module Field Wiring Information

The following figure provides information for connecting field wiring to the user terminal board on the 4-Channel Analog Current Input Module.

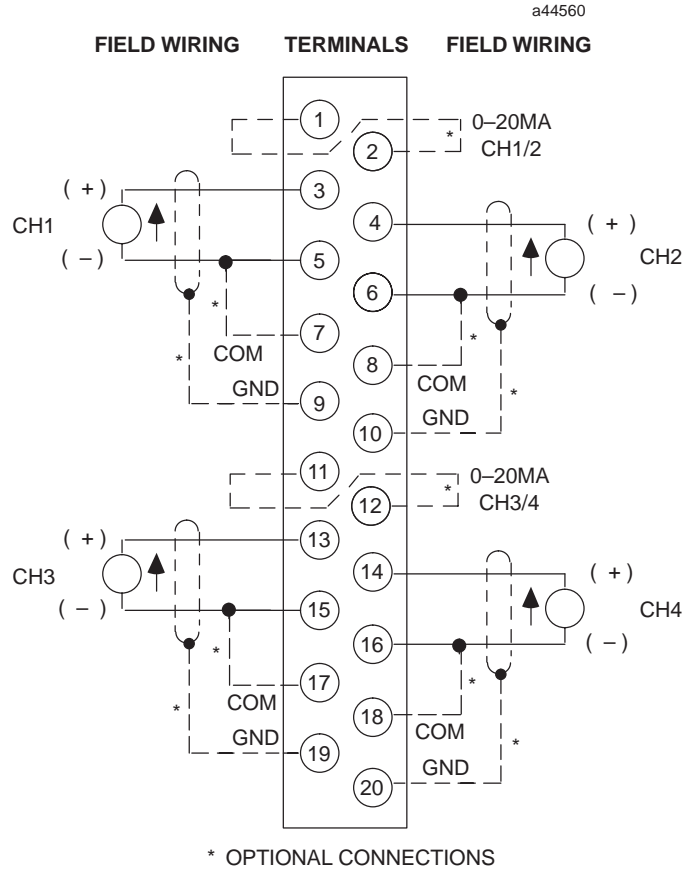

Figure 10-8. Field Wiring for 4 Channel Analog Current Input Module

Note

In order to limit common-mode voltages, each current source common line may also be tied to its associated COM terminal if the source is floating. These optional connections are shown in the figure above.

Please refer to Chapter 2 for wiring and shield ground connection details.

Analog Voltage Input - 16 Channel IC693ALG222

The *16-Channel Analog Voltage Input* module provides up to 16 single-ended or eight differential input channels, each capable of converting an analog input signal to a digital value for use as required by your application. This module provides two input ranges:

- 0 to 10 V (unipolar)
- -10 to +10 V (bipolar)

Voltage Ranges and Input Modes

The default input mode and range is single-ended, unipolar, with the user data scaled so that 0 volts corresponds to a count of 0 and 10 volts corresponds to a count of +32000. The other range and mode are selected by changing the configuration parameters using the Logicmaster 90-30/20/Micro or CIMPLICITY Control configurator software, or the Hand-Held Programmer. The range can be configured for bipolar -10 to +10 V where -10 V corresponds to a count of -32000, 0 V corresponds to a count of 0, and +10 V corresponds to a count of +32000.

High and Low alarm limits are available on all ranges. Ranges can be configured on a per channel basis.

Power Requirements and LEDs

This module consumes a maximum of 112 mA from the 5V bus on the PLC backplane. It also requires a maximum of 41 mA from the backplane Isolated+24 Volt DC supply to power the on-board power converter that provides isolated $\pm 5V$ supplies to power the user-side circuitry (see Table 3-9, *Specifications*).

There are two green LED indicators on the module which provide module and user supply status. The top LED, **MODULE OK** provides module status information on power-up as follows:

- *ON*: status is OK, module configured
- *OFF*: no backplane power or software not running (watchdog timer timed out)
- *Continuous rapid flashing*: configuration data not received from CPU
- *Slow flashes, then OFF*: failed power-up diagnostics or encountered code execution error

The bottom LED, **Power Supply OK**, indicates that the internally generated user-side +5V supply is above a minimum designated level.

Location in System

This module can be installed in any I/O slot of a 5 or 10-slot baseplate in a Series 90-30 PLC system.

References Used

The number of 16-Channel Analog Voltage Input modules which may be installed in a system depends on the amount of %AI and %I references available. Each module uses 1 to 16 %AI references (depending on the number of channels enabled) and from 8 to 40 %I references (depending on alarm status configuration).

The available %AI references are: 64 with CPUs 311, 313, and 323; 128 with CPU331; 1024 with CPUs 340 and 341; and 2048 with CPUs 350 – 364.

The maximum number of 16-Channel Analog Voltage Input modules which may be installed in a system are:

- 4 in a system using CPUs 311, 313, or 323
- 8 in a system using CPU331
- 12 in a system using CPUs 340 or 341
- 51 in a system using CPUs 350 – 364

When planning the module configuration for your application you must also consider the load capacity of the installed power supply and the total load requirements of all modules that are installed in the baseplate.

Refer to the *Series 90-30 Programmable Controller Installation Manual*, GFK-0356 for details on power supplies and module load requirements.

Table 10-3. Specifications for 16-Channel Analog Voltage Input Module, IC693ALG222

Number of Channels	1 to 16 selectable, single-ended 1 to 8 selectable, differential
Input Current Ranges	0V to +10V (unipolar) or -10V to +10V (bipolar); selectable each channel
Calibration	Factory calibrated to: 2.5 mV per count on 0V to +10V (unipolar) range 5 mV per count on -10 to +10V (bipolar) range
Update Rate	6 msec (all 16 single-ended channels) 3 msec (all 8 differential channels)
Resolution at 0V to +10V	2.5 mV (1 LSB = 2.5 mV)
Resolution at -10V to +10V	5 mV (1 LSB = 5 mV)
Absolute Accuracy ‡	± 0.25% of full scale @ 25°C (77°F) ± 0.5% of full scale over specified operating temperature range
Linearity	< 1 LSB
Isolation	1500 volts between field side and logic side
Common Mode Voltage (Differential) †	± 11V (bipolar range) †
Cross-Channel Rejection	> 80 db from DC to 1 kHz
Input Impedance	>500K ohms (single-ended mode) >1M ohms (differential mode)
Input Filter Response	41 Hz (single-ended mode) 82 Hz (differential mode)
Internal Power Consumption	112 mA (maximum) from the backplane +5 VDC bus 41 mA (maximum) from the backplane Isolated +24 VDC supply

Refer to Appendix B for product standards and general specifications.

† The summation of the differential input, common-mode voltage, and noise must not exceed ±11 volts when referenced to COM.

‡ In the presence of severe RF interference (IEC 801-3, 10V/m), accuracy may be degraded to ±5% FS.

CPU Interface to the IC693ALG 222 Analog Voltage Input Module

The Series 90-30 PLC uses the data within the %AI data table to record analog values for use by the programmable controller. This scheme for the 16-Channel Analog Voltage Input module is shown below. More information on the CPU interface to analog modules can be found at the beginning of this chapter.

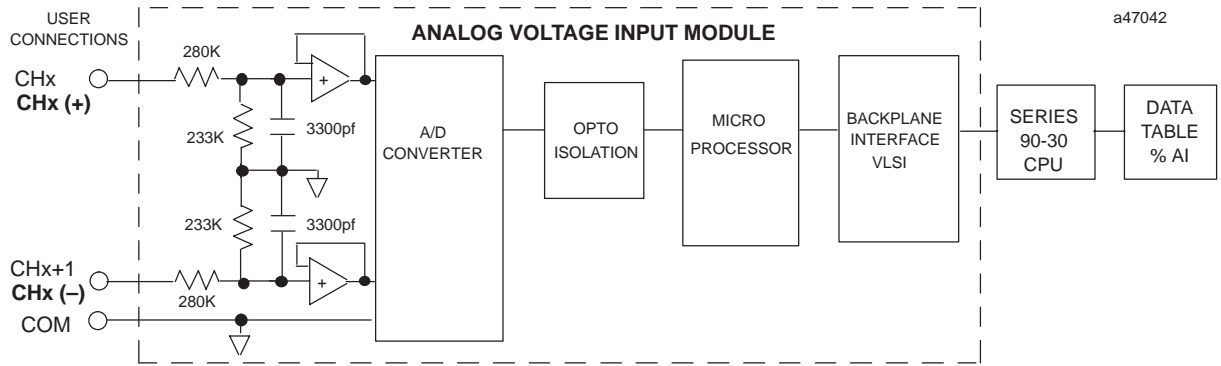

NOTE: CHx AND CHx+1 INDICATE SINGLE-ENDED MODE; CHx (+) AND CHx (-) INDICATE DIFFERENTIAL MODE

Figure 10-9. 16-Channel Analog Voltage Input Module Block Diagram - IC693ALG222

Placement of A/D Bits within the Data Tables

Since converters used in the analog modules are 12-bit converters, not all of the 16 bits in the data tables contain data required for the conversion. A version of the 12 bits is placed within the 16-bit data word corresponding to the analog point (in the %AI table). The Series 90-30 PLC system handles the integration differently for the various analog modules.

The CPU does not manipulate the data from the input modules before placing it within the word in the %AI data table. The bits in the %AI data table which were not used in the conversion by the input module are either forced to 0 (zero) by the analog input module. Placement of the 12 data bits from the A/D converter for an analog current input data word for the 16-Channel Analog Voltage Input module in unipolar range is shown below.

MSB												LSB			
X	D11	D10	D9	D8	D7	D6	D5	D4	D3	D2	D1	D0	X	X	X

X=not converted bits

Analog values are scaled over the range of the converter. Factory calibration adjusts the analog value per bit (resolution) to a multiple of full scale (that is, 2.5 mV/bit for unipolar; 5 mV/bit for bipolar). This calibration leaves a normal 12-bit converter with 4000 counts (normally $2^{12} = 4096$ counts). The data is then scaled with the 4000 counts over the analog range. For example, the data to the A/D converter for the 16-Channel Analog Voltage Input is scaled as shown below.

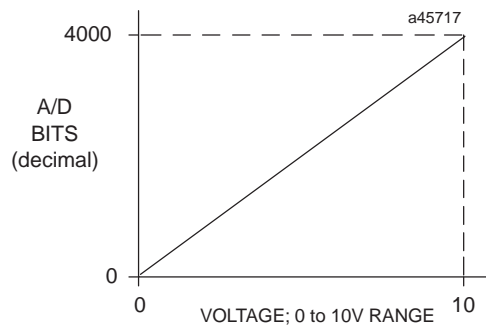

Figure 10-10. A/D Bits vs. Voltage Input for IC693ALG222

IC693ALG222 Analog Module Field Wiring Connections

Connections to this module from user devices are made to screw terminals on a removable 20-terminal connector block mounted on the front of the module. The actual terminals used are described in the following table and are shown in the following wiring diagrams.

Terminal Assignments

Pin assignments for the 20 terminal I/O connector on the 16-Channel Analog Voltage Input module are as shown in the following table.

Table 10-4. Terminal Pin Assignments for IC693ALG222

Pin Number	Signal Name	Signal Definition
1	n/a	not used
2	n/a	not used
3	CH1	Single Ended Channel 1, Differential Channel 1 (Positive terminal)
4	CH2	Single Ended Channel 2, Differential Channel 1 (Negative terminal)
5	CH3	Single Ended Channel 3, Differential Channel 2 (Positive terminal)
6	CH4	Single Ended Channel 4, Differential Channel 2 (Negative terminal)
7	CH5	Single Ended Channel 5, Differential Channel 3 (Positive terminal)
8	CH6	Single Ended Channel 6, Differential Channel 3 (Negative terminal)
9	CH7	Single Ended Channel 7, Differential Channel 4 (Positive terminal)
10	CH8	Single Ended Channel 8, Differential Channel 4 (Negative terminal)
11	CH9	Single Ended Channel 9, Differential Channel 5 (Positive terminal)
12	CH10	Single Ended Channel 10, Differential Channel 5 (Negative terminal)
13	CH11	Single Ended Channel 11, Differential Channel 6 (Positive terminal)
14	CH12	Single Ended Channel 12, Differential Channel 6 (Negative terminal)
15	CH13	Single Ended Channel 13, Differential Channel 7 (Positive terminal)
16	CH14	Single Ended Channel 14, Differential Channel 7 (Negative terminal)
17	CH15	Single Ended Channel 15, Differential Channel 8 (Positive terminal)
18	CH16	Single Ended Channel 16, Differential Channel 8 (Negative terminal)
19	COM	Common connection for Single Ended Channels
20	GND	Frame ground connections for cable shields

IC693ALG222 Analog Input Module Field Wiring Diagrams

The following figures provide information for connecting field wiring to the user terminal board on the 16-Channel Analog Voltage Input Module.

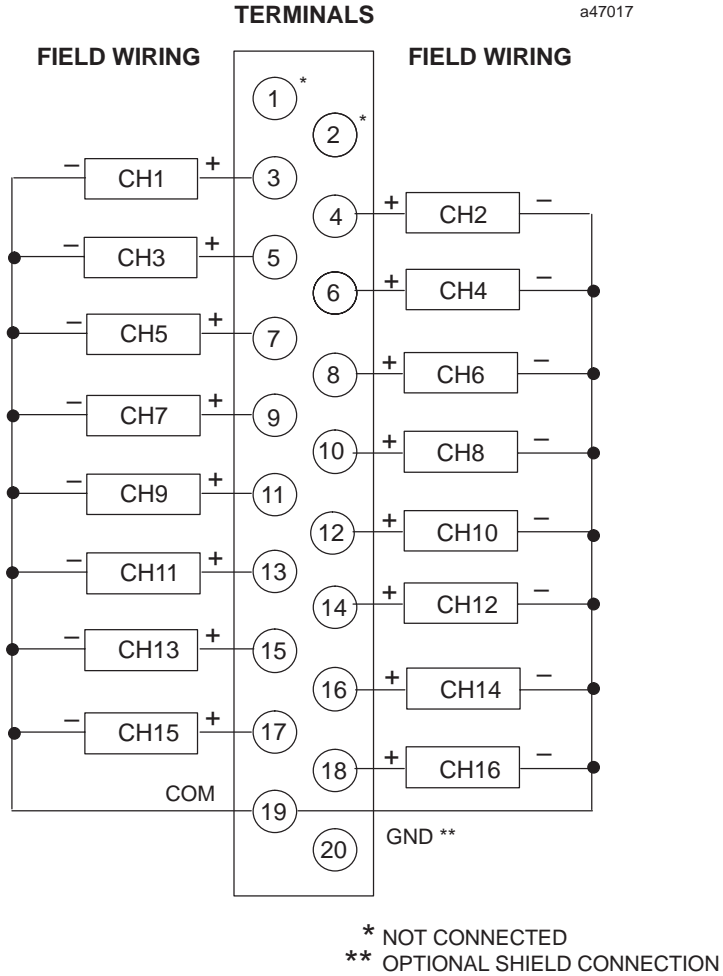

Figure 10-11. Field Wiring for 16-Channel Analog Voltage Input Module - IC693ALG222 (Single-Ended Mode)

Note

Please refer to Chapter 2 for wiring and shield ground connection details.

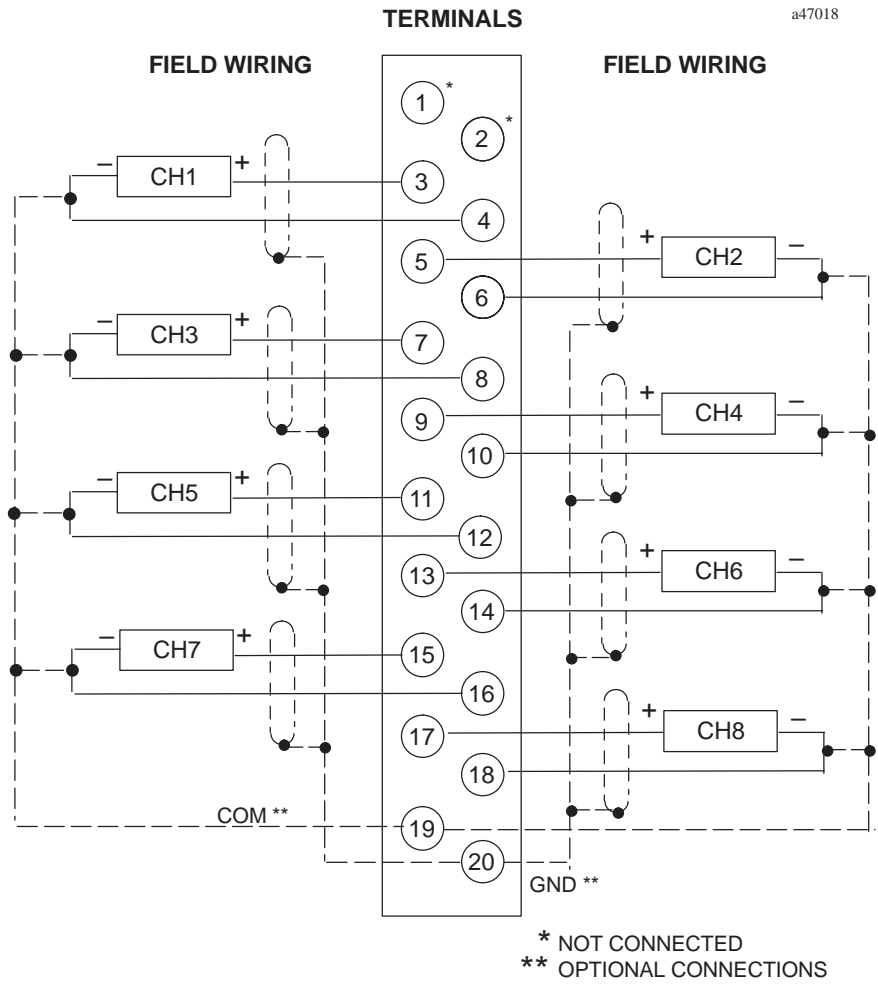

Figure 10-12. Field Wiring for 16-Channel Analog Voltage Input Module - IC693ALG222 (Differential Mode)

Note

Please refer to Chapter 2 for wiring and shield ground connection details.

IC693ALG222 Analog Voltage Input Block Diagram

The following figure is a block diagram of the 16-Channel Analog Voltage Input Module.

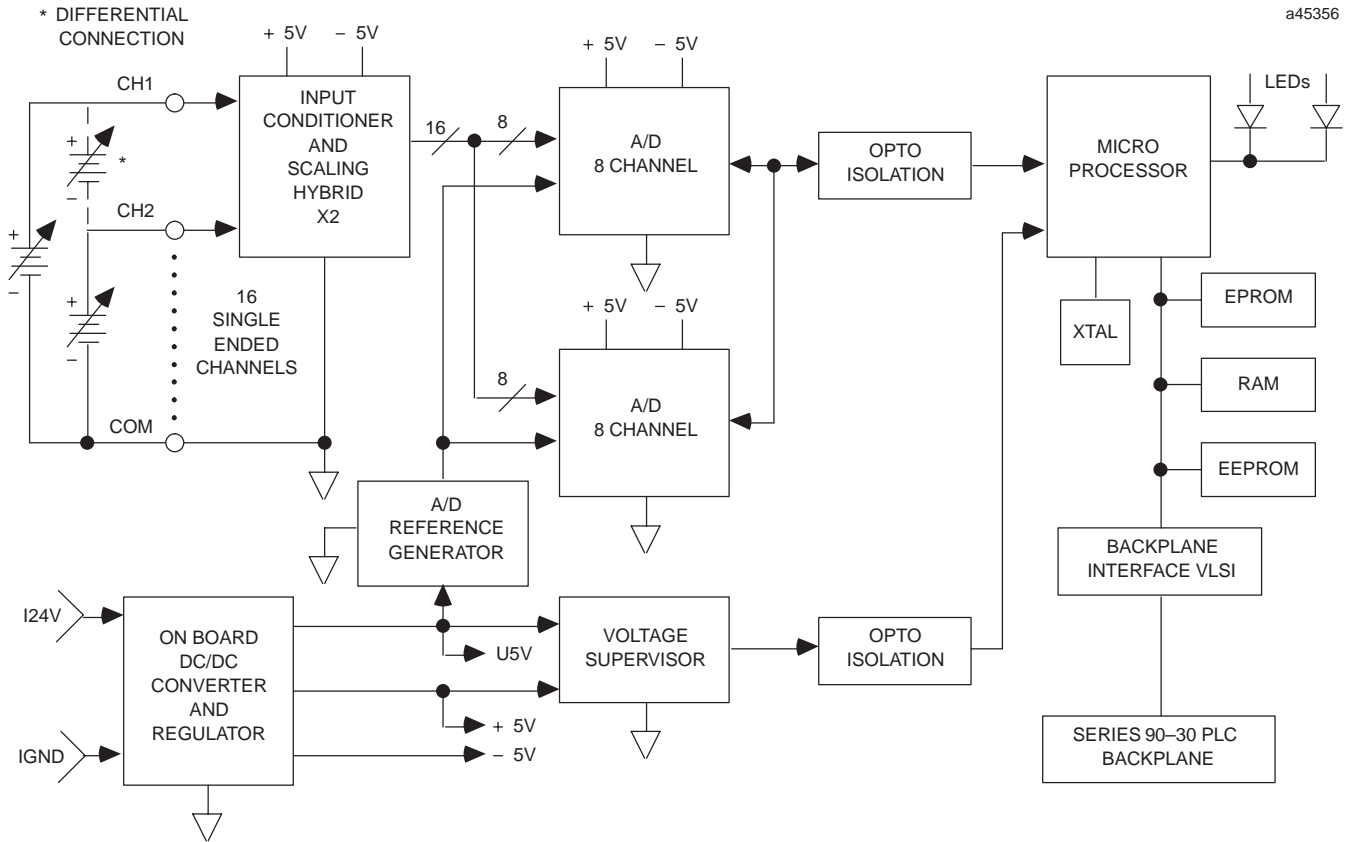

Figure 10-13. 16-Channel Analog Voltage Input Module Block Diagram - IC693ALG222

IC693ALG222 Analog Input Module Configuration

The 16-Channel Analog Voltage Input module can be configured using either the Logicmaster 90-30/20/Micro Programming Software configurator function or with the Hand-Held Programmer.

The parameters that may be configured are described in the following table. Configuration procedures using Logicmaster 90-30/20/Micro Programming Software and the Hand-Held Programmer are described in the following pages.

Table 10-5. Configuration Parameters for IC693ALG222

Parameter Name	Description	Values	Default Values	Units
<i>Active Channels</i>	Number of channels converted	1 through 16	1 (Logicmaster 90-30/20/Micro) 16 (Hand-Held programmer)	n/a
<i>RefAdr</i>	Starting address for %AI reference type	standard range	%AI0001, or next highest available address	n/a
<i>RefAdr</i>	Starting address for %I reference type	standard range	%I00001, or next highest available address	n/a
<i>%I Size</i>	Number of %I status locations	8, 16, 24, 32, 40	8 (Logicmaster 90-30) 40 (Hand-Held Programmer)	bits
<i>Range</i>	Range	0 to 10V or -10 to 10V	0 to 10V	n/a
<i>Alarm Low</i>	Low limit alarm value	-32767 to +32759	0	User counts
<i>Alarm High</i>	High limit alarm value	-32766 to +32760	+32000	User counts

For more information on configuration, see

- *Configuration Using Logicmaster 90-30/20/Micro Programming Software* beginning on page 3-25 and
- *Configuration Using the Hand-Held Programmer* beginning on page 3-29.

IC693ALG222 Configuration Using Logicmaster Software

This section describes how you can configure the 16-Channel High Density Analog Voltage Input module using the configurator function in Logicmaster 90-30/20/Micro Programming Software. *Configuration can also be done using CIMPLICITY Control Programming Software. For details refer to the CIMPLICITY Control online help.*

To configure a 16-Channel Analog Voltage Input Module on the I/O Configuration Rack screen:

1. Move the cursor to the slot where the module will be located, and press the **m30 io** softkey (F1). In the following example screen, the module will be placed in slot 5 of the main rack.

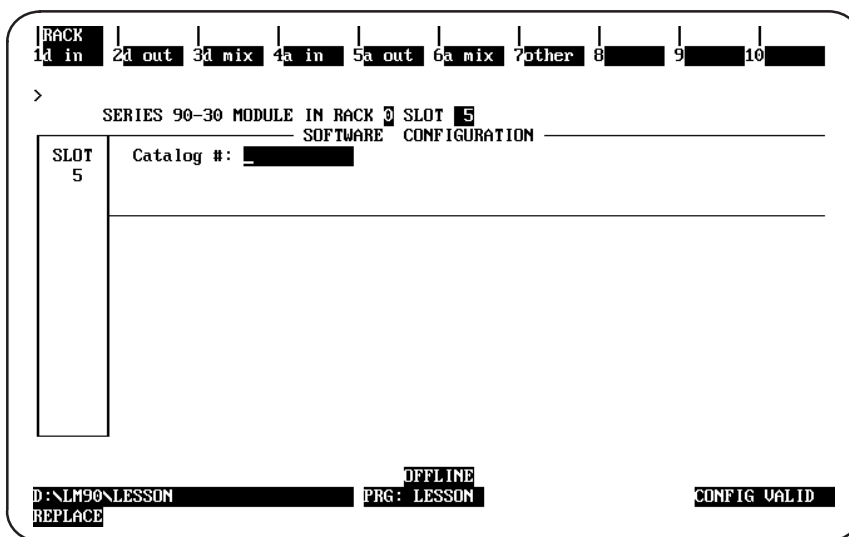

2. Press the **a in**, softkey (F4) to display a list of available analog input modules and their catalog numbers.

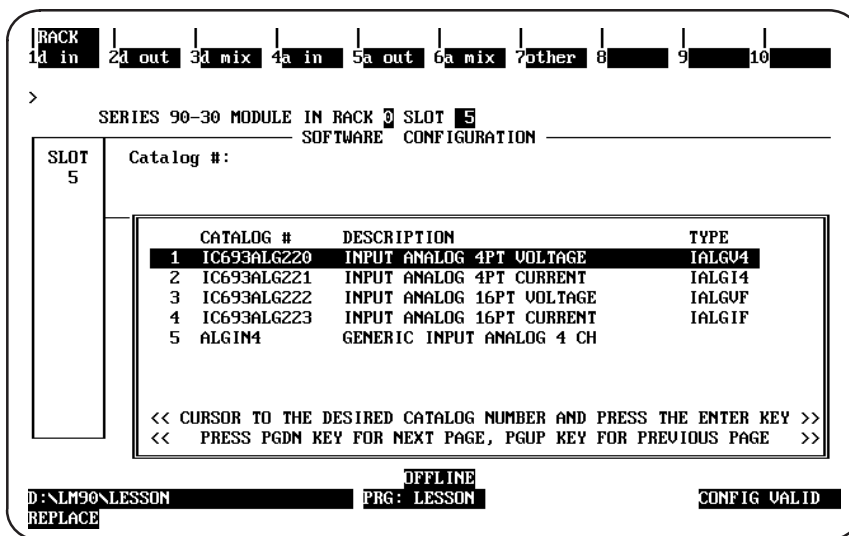

- To select the 16-Channel Analog Voltage Input Module, position the cursor on the catalog number for the module, IC693ALG222, and press the **Enter** key.

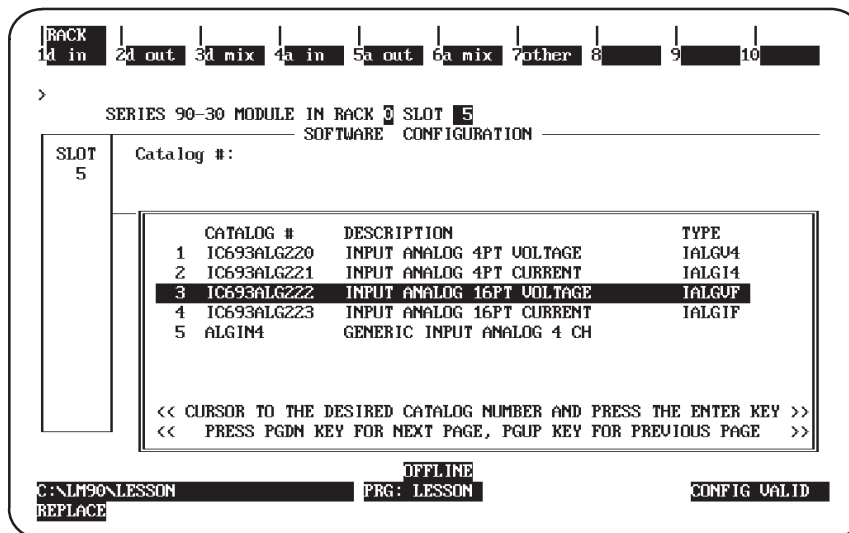

- After pressing the Enter key, the first detail screen, shown below, is displayed. You can then configure the module as required for your application.

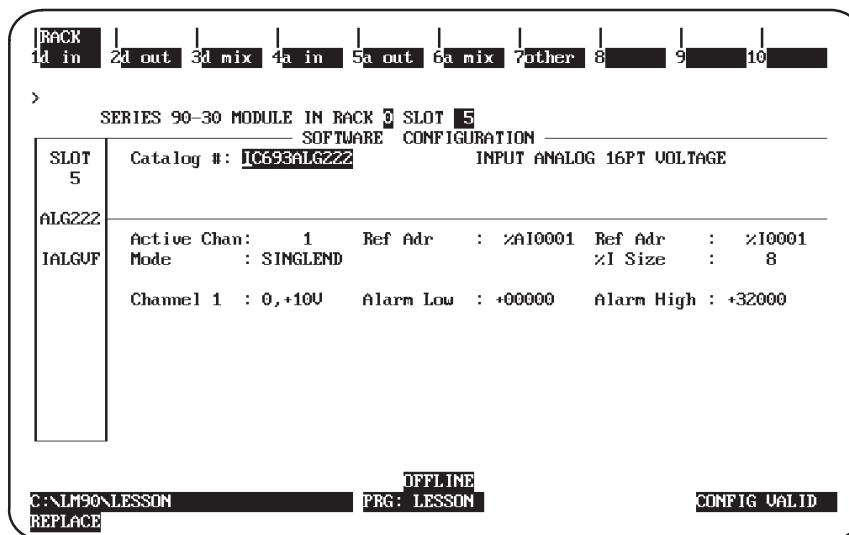

Note

Only enabled (active) channels are displayed on the screen

- Use the parameter descriptions provided in the following table to help you make selections for the parameters on this screen.

Table 10-6. Parameter Descriptions for Configuration

Parameter	Description
Active Channel	Enter a number from 1* through 16 for Single Ended or 1* through 8 for Differential . This number represents the number of channels to be converted. Channels are scanned in sequential, contiguous order, with channel No. 1 being the first channel scanned. If more than eight channels are selected, a second detail screen will be displayed to allow you to enter data in channels 9 through 16.
Reference Address	The first Reference Address field contains the reference address for %AI data. The address points to the location in %AI memory where input data to the module begins. Each channel provides 16 bits of analog input data as an integer value from 0 to 32,760 or -32,767 to 32,752, depending on the range type selected.
Reference Address	The second Reference Address field contains the reference address for %I data. The address points to the location in %I memory where status information from the module begins. You can select the number of %I status locations reported to the PLC by editing the value in the %I Size field.
Mode	The Mode field describes what type user connection to the terminal board is desired. In *Single Ended mode, there are 16 inputs referenced to a single common. In Differential mode each of the 8 inputs has its own signal and common, thereby using two points on the terminal board for each channel.
%I Size	Enter the number of %I locations reported to the PLC. Choices are 0, 8, 16, 24, 32, or 40. The data is brought back in the following format:
	<u>First eight %I locations:</u> (available for %I SIZE values 8, 16, 24, 32, and 40)
	<ul style="list-style-type: none"> ● %I = Module OK: 0 = module NOT OK; 1 = module OK. ● %I+1 = User Supply OK: 0 = below limit; 1 = user supply OK. ● %I+2 through %I+7 = Reserved for future modules.
	<u>Second eight %I locations:</u> (available for %I SIZE values 16, 24, 32, and 40)
	<ul style="list-style-type: none"> ● %I+8 = Channel No. 1 ALARM LO 0 = above limit; 1 = below or equal to limit. ● %I+9 = Channel No. 1 ALARM HI: 0 = below limit; 1 = above or equal to limit. ● %I+10 = Channel No. 2 ALARM LO: 0 = above limit; 1 = below or equal to limit. ● %I+11 = Channel No. 2 ALARM HI: 0 = below limit; 1 = above or equal to limit. ● %I+12 = Channel No. 3 ALARM LO: 0 = above limit; 1 = below or equal to limit. ● %I+13 = Channel No. 3 ALARM HI: 0 = below limit; 1 = above or equal to limit. ● %I+14 = Channel No. 4 ALARM LO: 0 = above limit; 1 = below or equal to limit. ● %I+15 = Channel No. 4 ALARM HI: 0 = below limit; 1 = above or equal to limit.
<u>Third eight %I locations:</u> (available for %I SIZE values 24, 32, and 40)	
<ul style="list-style-type: none"> ● %I+16 = Channel No. 5 ALARM LO 0 = above limit; 1 = below or equal to limit. ● %I+17 = Channel No. 5 ALARM HI: 0 = below limit; 1 = above or equal to limit. ● %I+18 = Channel No. 6 ALARM LO: 0 = above limit; 1 = below or equal to limit. ● %I+19 = Channel No. 6 ALARM HI: 0 = below limit; 1 = above or equal to limit. ● %I+20 = Channel No. 7 ALARM LO: 0 = above limit; 1 = below or equal to limit. ● %I+21 = Channel No. 7 ALARM HI: 0 = below limit; 1 = above or equal to limit. ● %I+22 = Channel No. 8 ALARM LO: 0 = above limit; 1 = below or equal to limit. ● %I+23 = Channel No. 8 ALARM HI: 0 = below limit; 1 = above or equal to limit. 	
<u>Fourth eight %I locations:</u> (available for %I SIZE values 32 and 40)	
<ul style="list-style-type: none"> ● %I+24 = Channel No. 9 ALARM LO 0 = above limit; 1 = below or equal to limit. ● %I+25 = Channel No. 9 ALARM HI: 0 = below limit; 1 = above or equal to limit. ● %I+26 = Channel No. 10 ALARM LO: 0 = above limit; 1 = below or equal to limit. ● %I+27 = Channel No. 10 ALARM HI: 0 = below limit; 1 = above or equal to limit. ● %I+28 = Channel No. 11 ALARM LO: 0 = above limit; 1 = below or equal to limit. ● %I+29 = Channel No. 11 ALARM HI: 0 = below limit; 1 = above or equal to limit. ● %I+30 = Channel No. 12 ALARM LO: 0 = above limit; 1 = below or equal to limit. ● %I+31 = Channel No. 12 ALARM HI: 0 = below limit; 1 = above or equal to limit. 	

Table 10–6. Parameter Descriptions for Configuration (continued)

Parameter	Description
%I Size (cont'd)	<p><u>Fifth eight %I locations:</u> (available for %I SIZE value 40)</p> <ul style="list-style-type: none"> ● %I+32 = Channel No. 13 ALARM LO 0 = above limit; 1 = below or equal to limit. ● %I+33 = Channel No. 13 ALARM HI: 0 = below limit; 1 = above or equal to limit. ● %I+34 = Channel No. 14 ALARM LO: 0 = above limit; 1 = below or equal to limit. ● %I+35 = Channel No. 14 ALARM HI: 0 = below limit; 1 = above or equal to limit. ● %I+36 = Channel No. 15 ALARM LO: 0 = above limit; 1 = below or equal to limit. ● %I+37 = Channel No. 15 ALARM HI: 0 = below limit; 1 = above or equal to limit. ● %I+38 = Channel No. 16 ALARM LO: 0 = above limit; 1 = below or equal to limit. ● %I+39 = Channel No. 16 ALARM HI: 0 = below limit; 1 = above or equal to limit.
Range	<p>Select the range. Choices are *0 to 10V or –10 to 10V. In the 0 to 10V default range, input voltage values ranging from 0 to 10V report 0 to 32,000 integer values to the CPU. In the –10 to 10V range, input voltage values ranging from –10 to 10V report –32000 to 32,000 integer values to the CPU.</p>
Alarm Low	<p>Enter a value that causes an alarm low indication to be passed to the PLC. Each channel has a low limit alarm value (ALARM LO), which causes %I points to be set. Values entered without a sign are assumed to be positive. Value checking should be done to determine if the alarm low values are allowed for the appropriate range. The values allowed are:</p> <ul style="list-style-type: none"> ● 0 to 10V Range = 0 to 32760 ● –10 to 10V Range = –32767 to 32752
Alarm High	<p>Enter a value that causes an alarm high indication to be passed to the PLC. Each channel has a high limit alarm value (ALARM HI), which causes %I points to be set. Values entered without a sign are assumed to be positive. Value checking should be done to determine if the alarm high values are allowed for the appropriate range. The values allowed are:</p> <ul style="list-style-type: none"> ● 0 to 10V Range = 0 to 32760 ● –10 to 10V Range = –32767 to 32752

* Default selection.

6. Press Rack (Shift-F1) or the Escape key to return to the rack display.

Configuring IC693ALG222 Using Hand-Held Programmer

You can also configure the 16-Channel Analog Voltage Input module using the Hand-Held Programmer. In addition to the information in this section, refer to GFK-0402, the *Hand-Held Programmer for Series 90-30/20/Micro Programmable Controllers User's Manual* for more information on configuration of Intelligent I/O modules.

Although you can change the number of actively scanned channels with the Logicmaster 90-30/20/Micro configurator function, the Hand-Held Programmer does not support editing the number of actively scanned channels. If the 16-Channel Analog Voltage Input module is initialized by a Hand-Held Programmer, the number of actively scanned channels is 16.

If a module had been previously configured with Logicmaster 90-30/20/Micro software and the number of actively scanned channels has been changed from 16, that number will be displayed on the bottom line of the Hand-Held Programmer display following the *AI*. You can edit data with the Hand-Held Programmer only for the active channels, but can not change the number of actively scanned channels.

Module Present

If a module is physically present in a system, it can be added to the system's configuration by *reading* the module into it. For example, assume that a 16-Channel Analog Voltage Input module is installed in slot 3 of a Model 311 PLC system. It can be added to the configuration with the following sequence. Use the Up and Down cursor keys or the # key to display the selected slot.

Initial Display

```
R0:03 EMPTY >S
```

To add the IC693ALG222 module to the configuration, press the **READ/VERIFY** key. The following screen will be displayed:

```
R0:03 HI-DEN V >S
I40:I_
```

Selecting %I Reference

At this point the starting %I reference address for the status data returned from the module must be entered. Notice that the length of the status field (**40**) is displayed as the first two digits following the first **I** on the second line of the display.

Note

This field cannot be changed with the Hand-Held programmer. However, it can be changed using the Logicmaster 90-30/20/Micro software configurator function. The Hand-Held Programmer will always reflect the currently active length of the status field.

Pressing the **ENT** key will allow the PLC to select the starting address of the status data. You can select a specific starting address by pressing the key sequence for the desired address and pressing the **ENT** key. For example to specify the starting address as I17, press the key sequence **1, 7, ENT**. The following screen will be displayed:

```
R0:03 HI-DEN V >S
I40:I17-I56
```

Selecting %AI Reference

After the starting %I address has been selected, pressing the **ENT** key again will cause the following screen to be displayed:

```
R0:03 HI-DEN V >S
AI16:AI_
```

This screen allows you to select the starting address for the %AI reference. Note that the length of the status field (**16**) is displayed as the first two digits following the first **AI** on the second line of the display.

Note

This field cannot be changed with the Hand-Held programmer. However, it can be changed using the Logicmaster 90-30/20/Micro software configurator function. The Hand-Held Programmer will always reflect the currently active length of the status field.

In the AI field you can select the next available address (the default) by pressing the **ENT** key or by entering a specific address. To enter a specific address, press the starting reference number keys and the **ENT**. key (for example **3, 5**, then **ENT**).

```
R0:03 HI-DEN V >S
AI16:AI035-AI051
```

You can press the **CLR** key at any time to abort the configuration you have just selected and return the slot to *EMPTY*.

Removing Module From Configuration

If required, this module can be removed from the current configuration. Assume that the module is currently configured in rack 0, slot 3. It can be deleted with the following sequence:

Initial Display

```
R0:03 HI-DEN V >S
AI16:AI_
```

To delete the module, press the **DEL**, **ENT** key sequence. The display will then be:

```
R0:03 EMPTY >S
```

Selecting Module Mode

To display the module mode, press the **→** key. The display will show the current mode of the module. The default mode is Single Ended.

Initial Display

```
R0:03 HI-DEN V >S
HI-DEN V:SINGLE
```

You can toggle between the Single Ended and Differential modes by pressing the **±** key. Each mode will be selected as shown. The range selected is the one currently displayed.

Initial Display

```
R0:03 HI-DEN V >S
HI-DEN V:DIFFERE
```

When the desired mode for the module is displayed on the screen you can selected it by pressing the **ENT** key.

Selecting Input Channel Ranges

The range for each of the 16 channels can be displayed and selected or changed as described below. Assume that the %AI address is as previously selected.

Initial Display

```
R0:03 HI-DEN V >S
HI-DEN V:SINGLE
```

To display the channel ranges press the → key. The display will show Channel 1 (or the currently selected channel) and the first available range.

```
R0:03 HI-DEN V >S
CHAN 1: 0 - 10
```

You can toggle through the range for each channel by pressing the ± key. Each range will be displayed as shown. The range selected is the one currently displayed.

```
R0:03 HI-DEN V >S
CHAN 1:-10 - 10
```

Alarm Limits Display

To view the alarm limits for the channel currently displayed, press the → key again (the first time caused the channel ranges to be available for editing). The following screen is displayed:

```
R0:03 HI-DEN V >S
CH 1 LO:      0
```

The display is the entry field for the low alarm limit for the displayed channel (in this case, Channel 1). You can enter the desired low alarm limit value using the numeric keys and the ± key for specifying negative values. Enter the low alarm limit using a value within the valid limits as listed in Table 3-7. After you have entered the low alarm limit value, press the → key again to advance to the high alarm limit display for this channel. The following screen is displayed at this time.

```
R0:03 HI-DEN V >S
CH 1: HI: 32000
```

The display shows the entry field for the high alarm limit for the currently displayed channel. You can enter positive or negative numbers (see table 3-7) using the ± and numeric keys. After selecting the low and high alarm limits for channel 1 (or the currently displayed channel), you can view the next channel by pressing the → key.

```
R0:03 HI-DEN V >S
CHAN 2:0 - 10
```

Edit the range, and low and high alarm limits as described for Channel 1. All active channels can be changed in this manner. Return to the initial display screen by pressing the ENT key or by pressing the ← key until the initial screen is displayed.

Saved Configurations

Configurations that contain a 16-Channel Analog Voltage Input module can be saved to an EEPROM or MEM card and read into the CPU at a later time. MEM cards and EEPROMs containing these configurations can be read into any Release 4 or later CPU. Refer to Chapter 2 of the *Hand-Held Programmer User's Manual* for detailed information on the Save and Restore operations.

Analog Current Input - 16 Channel IC693ALG223

The *16-Channel Analog Current Input* module provides up to 16 single-ended input channels, each capable of converting an analog input signal to a digital value for use as required by your application. This module provides three input ranges:

- 4 to 20 mA
- 0 to 20 mA
- 4 to 20 mA Enhanced

Current Ranges

The default range is 4 to 20 mA with user data scaled so that 4 mA corresponds to a count of 0 and 20 mA corresponds to a count of 32000. The other ranges are selected by changing the configuration parameters using the IC641 configurator software or the Hand-Held Programmer. The range can be configured so that the input range is 0 to 20 mA with user data scaled so that 0 mA corresponds to a count of 0 and 20 mA corresponds to a count of 32000. Full 12-bit resolution is available over the 4 to 20 and 0 to 20 mA ranges.

A 4 to 20 mA Enhanced range can also be selected. When this range is selected, 0 mA corresponds to a count of -8000, 4 mA corresponds to a count of 0 (zero) and 20 mA corresponds to a count of +32000. The Enhanced range uses the same hardware as the 0 to 20 mA range but automatically provides 4 to 20 mA range scaling with the exception that negative digital values are provided to the user for input current levels between 4 mA and 0 mA. This gives you the capability of selecting a low alarm limit that detects when the input current falls from 4 mA to 0 mA, which provides for open-wire fault detection in 4 to 20 mA applications. High and Low alarm limits are available on all ranges. Ranges can be configured on a per channel basis. The module also reports module status and user-side supply status to the CPU.

Power Requirements and LEDs

This module consumes 120 mA from the 5V bus on the PLC backplane and also requires 65 mA plus current loop current(s) from a user supplied +24V supply (see Table 3-13, *Specifications*).

There are two green LED indicators on the module which provide module and user supply status. The top LED, **MODULE OK** provides module status information on power-up as follows:

- *ON*: status is OK, module configured;
- *OFF*: no backplane power or software not running (watchdog timer timed out);
- *Continuous rapid flashing*: configuration data not received from CPU;
- *Slow flashes, then OFF*: failed power-up diagnostics or encountered code execution error.

The bottom LED, **User Supply OK**, indicates that the user provided 24V supply is within specifications, thereby enabling the analog side of the module to work properly.

Location in System

This module can be installed in any I/O slot of a 5 or 10-slot baseplate in a Series 90-30 PLC system.

References Used

The number of 16-Channel Analog Current Input modules which may be installed in a system depends on the amount of %AI and %I references available. Each module uses 1 to 16 %AI references (depending on the number of channels enabled) and from 8 to 40 %I (depending on alarm status configuration) references.

The available %AI references are: 64 in a Model 311, Model 313, and Model 323 system, 128 in a Model 331 system, 1024 in a Model 340 and 341 system, and 2048 in a Model 351 and Model 352 system.

The maximum number of 16-Channel Analog Current Input modules which may be installed in a system are:

- 4 in a Model 311, Model 313, and Model 323 system
- 8 in a Model 331 system
- 12 in a Model 340 and Model 341 system
- 51 in a Model 351 and Model 352 system

When planning the module configuration for your application you must also consider the load capacity of the installed power supply and the total load requirements of all modules that are installed in the baseplate.

Refer to the *Series 90-30 Programmable Controller Installation Manual*, GFK-0356 for details on power supplies and module load requirements.

Table 10-7. Specifications for 16-Channel Analog Current Input Module, IC693ALG223

Number of Channels	1 to 16 selectable; single ended
Input Current Ranges	0 to 20 mA, 4 to 20 mA and 4 to 20 mA Enhanced (selectable per channel)
Calibration	Factory calibrated to: 4 μ A per count on 4 to 20 mA range 5 μ A per count on 0 to 20 mA and 4 to 20 mA Enhanced range
Update Rate	13 msec (all 16 channels)
Resolution at 4-20 mA	4 μ A (4 μ A/bit)
Resolution at 0-20 mA	5 μ A (5 μ A/bit)
Resolution at 4-20 mA Enhanced	5 μ A (5 μ A/bit)
Absolute Accuracy †	$\pm 0.25\%$ of full scale @ 25°C (77°F): $\pm 0.5\%$ of full scale over specified operating temperature range
Linearity	< 1 LSB from 4 to 20 mA (4 to 20 mA range) < 1 LSB from 100 μ A to 20 mA (0 to 20 mA and 4 to 20 mA Enhanced ranges)
Isolation	1500 volts between field side and logic side
Common Mode Voltage	0 volts (single-ended channels)
Cross-Channel Rejection	> 80 db from DC to 1 kHz
Input Impedance	250 ohms
Input Low Pass Filter Response	19 Hz
External Supply Voltage Range	20 to 30 VDC
External Supply Voltage Ripple	10%
Internal Power Consumption	120 mA from the +5 volt bus on the backplane 65 mA from 24 VDC external user supply (in addition to current loop currents)

Refer to data sheet GFK-0867C, or later revision for product standards and general specifications.

† In the presence of severe RF interference (IEC 801-3, 10V/m), accuracy may be degraded to $\pm 5\%$ FS.

CPU Interface to the IC693ALG223 Analog Current Input Module

The Series 90-30 PLC uses the data within the %AI data table to record analog values for use by the programmable controller. This scheme is shown in Figure 3-25 for the 16-Channel Analog Current Input module. *More detailed information on the CPU interface to analog modules can be found at the beginning of this chapter.*

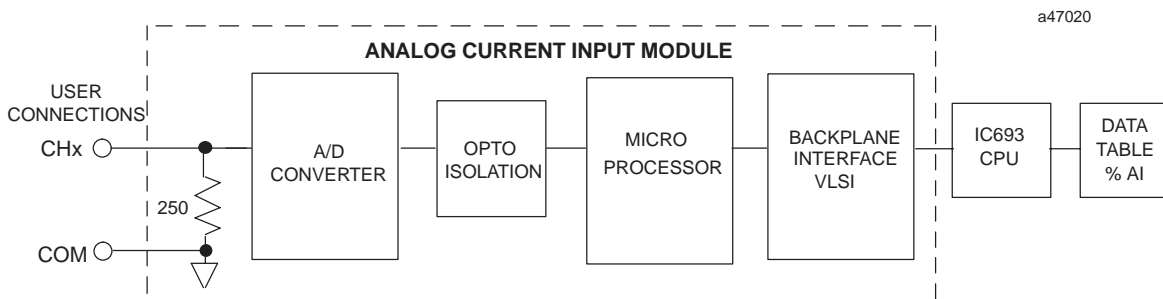

Figure 10-14. 16-Channel Analog Current Input Module Block Diagram - IC693ALG223

Placement of A/D Bits within the Data Tables

Since converters used in the analog modules are 12-bit converters, not all of the 16 bits in the data tables contain data required for the conversion. A version of the 12 bits is placed within the 16-bit data word corresponding to the analog point (in the %AI table). The Series 90-30 PLC system handles the integration differently for the various analog modules.

The CPU does not manipulate the data from the input modules before placing it within the word in the %AI data table. The bits in the %AI data table which were not used in the conversion by the input module are forced to 0 (zero) by the analog input module. Placement of the 12 data bits from the A/D converter for an analog current input data word for the 16-Channel Analog Current Input module is shown below.

MSB															LSB
X	D11	D10	D9	D8	D7	D6	D5	D4	D3	D2	D1	D0	X	X	X

X=not converted bits

Analog values are scaled over the range of the converter. Factory calibration adjusts the analog value per bit (resolution) to a multiple of full scale (that is, 4 μA/bit). This calibration leaves a normal 12-bit converter with 4000 counts (normally $2^{12} = 4096$ counts). The data is then scaled with the 4000 counts over the analog range. For example, the data to the A/D converter for the 16-Channel Analog Current Input is scaled as shown in the following figure.

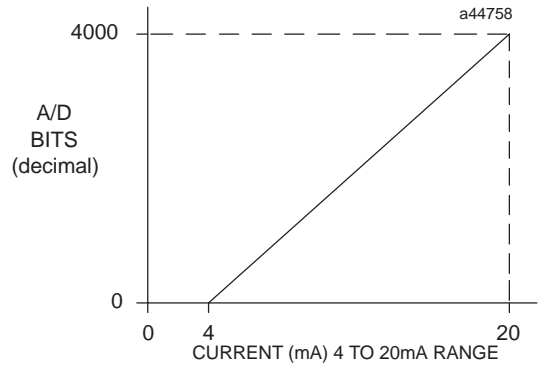

Figure 10-15. A/D Bits vs. Current Input for IC693ALG223

IC693ALG223 Configuration

The 16-Channel Analog Current Input module can be configured using either the Logicmaster 90-30/20/Micro or CIMPLICITY Control Programming Software configurator function, or with the Hand-Held Programmer.

The parameters that may be configured are described in the following table. Configuration procedures using Logicmaster 90-30/20/Micro Programming Software and the Hand-Held Programmer are described in the following pages.

Table 10-8. Configuration Parameters

Parameter Name	Description	Values	Default Values	Units
<i>Active Channels</i>	Number of channels converted	1 through 16	1 (Logicmaster 90-30/20/Micro) 16 (Hand-Held programmer)	n/a
<i>Ref Adr</i>	Starting address for %AI reference type	standard range	%AI0001, or next highest available address	n/a
<i>Ref Adr</i>	Starting address for %I reference type	standard range	%I00001, or next highest available address	n/a
<i>%I Size</i>	Number of %I status locations	8, 16, 24, 32, 40	8 (Logicmaster 90-30/20/Micro) 40 (Hand-Held Programmer)	bits
<i>Range</i>	Type of input and range	4-20, 0-20, or 4-20+ (Enhanced)	4-20	n/a
<i>Alarm Low</i>	Low limit alarm value	-8000 to +32759	0	User counts
<i>Alarm High</i>	High limit alarm value	-7999 to +32760	+32000	User counts

For more information on configuration, see

- *Configuration Using Logicmaster 90-30/20/Micro Programming Software* beginning on page 3-42
- *Configuration Using the Hand-Held Programmer* beginning on page 3-46

Configuring IC693ALG223 Using Logicismaster Software

This section describes how you can configure the 16-Channel High Density Analog Current Input module using the configurator function in Logicismaster 90-30/20/Micro programming software. *Configuration can also be done using CIMPLICITY Control Programming Software. For details refer to the CIMPLICITY Control online help.*

To configure a 16-Channel Analog Input Module on the I/O Configuration Rack screen:

1. Move the cursor to the slot where the module will be located, and press the **m30 io** softkey (F1). In the following example screen, the module will be placed in slot 5 of the main rack.

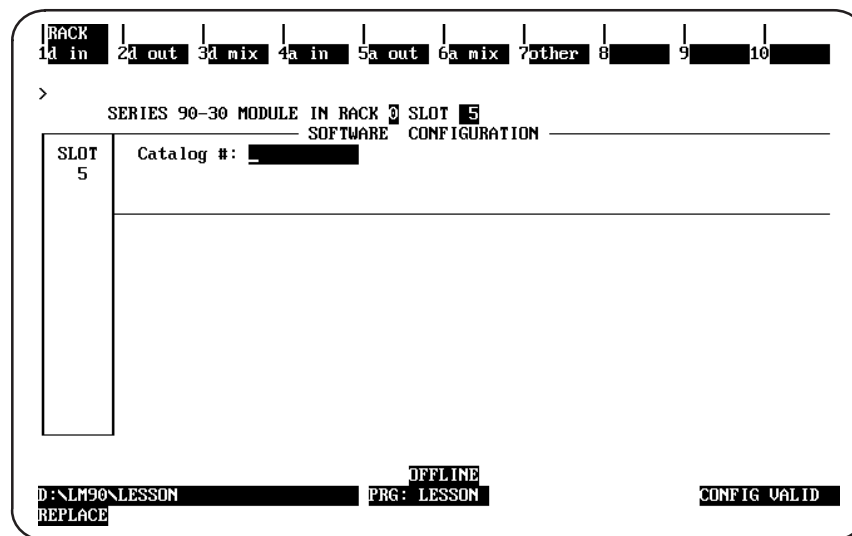

2. Press the **a in**, softkey (F4) to display a list of available analog input modules and their catalog numbers.

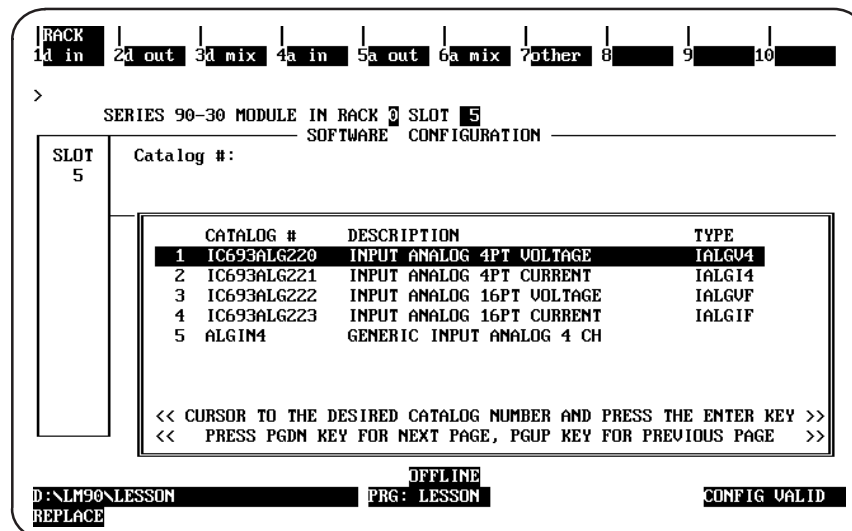

- To select the 16-Channel Analog Input Module, position the cursor on the catalog number for the module, IC693ALG223, and press the **Enter** key.

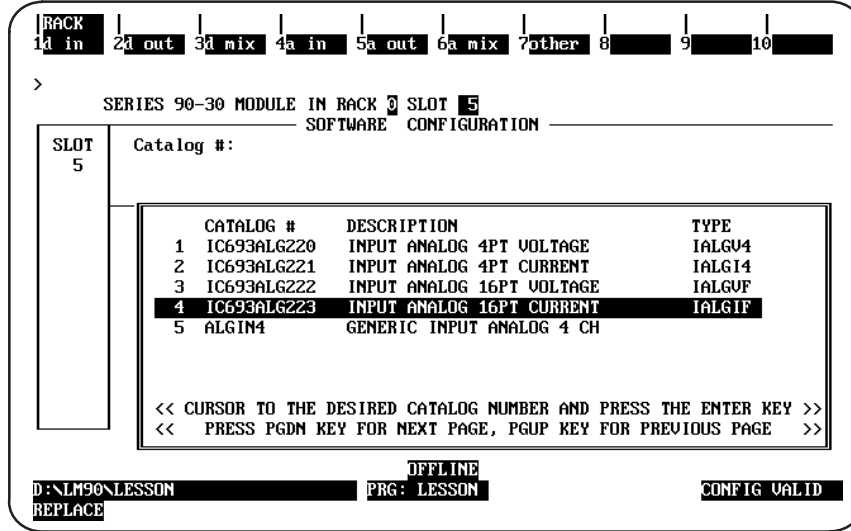

- After pressing the Enter key, the first detail screen, shown below, is displayed.

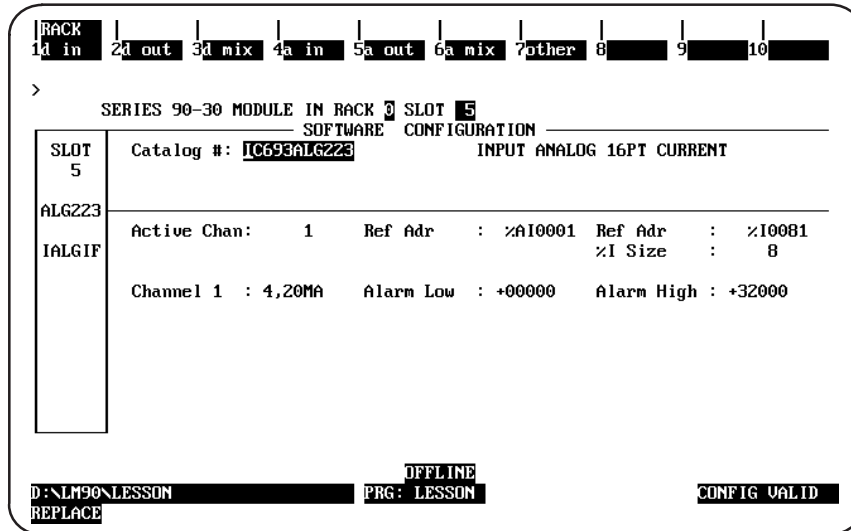

Note

Only enabled (active) channels are displayed on the screen

- Use the parameter descriptions provided in the following table to help you make selections for the parameters on this screen.

Table 10-9. Parameter Descriptions for Configuration

Parameter	Description
Active Channel	Enter a number from 1* through 16. This number represents the number of channels to be converted. Channels are scanned in sequential, contiguous order, with channel No. 1 being the first channel scanned. If more than eight channels are selected, a second detail screen will be displayed to allow you to enter data in channels 9 through 16.
Reference Address	The first Reference Address field contains the reference address for %AI data. The address points to the location in %AI memory where input data to the module begins. Each channel provides 16 bits of analog input data as an integer value from 0 to 32,760 or -8,000 to 32,760, depending on the range type selected.
Reference Address	The second Reference Address field contains the reference address for %I data. The address points to the location in %I memory where status information from the module begins. You can select the number of %I status locations reported to the PLC by editing the value in the %I Size field.
%I Size	Enter the number of %I locations reported to the PLC. Choices are 8, 16, 24, 32, or 40. The data is brought back in the following format:
	<u>First eight %I locations:</u> (available for %I SIZE values 8, 16, 24, 32, and 40)
	<ul style="list-style-type: none"> ● %I = Module OK: 0 = module NOT OK; 1 = module OK. ● %I+1 = User Supply OK: 0 = below limit; 1 = user supply OK. ● %I+2 through %I+7 = Reserved for future modules.
	<u>Second eight %I locations:</u> (available for %I SIZE values 16, 24, 32, and 40)
	<ul style="list-style-type: none"> ● %I+8 = Channel No. 1 ALARM LO 0 = above limit; 1 = below or equal to limit. ● %I+9 = Channel No. 1 ALARM HI: 0 = below limit; 1 = above or equal to limit. ● %I+10 = Channel No. 2 ALARM LO: 0 = above limit; 1 = below or equal to limit. ● %I+11 = Channel No. 2 ALARM HI: 0 = below limit; 1 = above or equal to limit. ● %I+12 = Channel No. 3 ALARM LO: 0 = above limit; 1 = below or equal to limit. ● %I+13 = Channel No. 3 ALARM HI: 0 = below limit; 1 = above or equal to limit. ● %I+14 = Channel No. 4 ALARM LO: 0 = above limit; 1 = below or equal to limit. ● %I+15 = Channel No. 4 ALARM HI: 0 = below limit; 1 = above or equal to limit.
<u>Third eight %I locations:</u> (available for %I SIZE values 24, 32, and 40)	
<ul style="list-style-type: none"> ● %I+16 = Channel No. 5 ALARM LO 0 = above limit; 1 = below or equal to limit. ● %I+17 = Channel No. 5 ALARM HI: 0 = below limit; 1 = above or equal to limit. ● %I+18 = Channel No. 6 ALARM LO: 0 = above limit; 1 = below or equal to limit. ● %I+19 = Channel No. 6 ALARM HI: 0 = below limit; 1 = above or equal to limit. ● %I+20 = Channel No. 7 ALARM LO: 0 = above limit; 1 = below or equal to limit. ● %I+21 = Channel No. 7 ALARM HI: 0 = below limit; 1 = above or equal to limit. ● %I+22 = Channel No. 8 ALARM LO: 0 = above limit; 1 = below or equal to limit. ● %I+23 = Channel No. 8 ALARM HI: 0 = below limit; 1 = above or equal to limit. 	
<u>Fourth eight %I locations:</u> (available for %I SIZE values 32 and 40)	
<ul style="list-style-type: none"> ● %I+24 = Channel No. 9 ALARM LO 0 = above limit; 1 = below or equal to limit. ● %I+25 = Channel No. 9 ALARM HI: 0 = below limit; 1 = above or equal to limit. ● %I+26 = Channel No. 10 ALARM LO: 0 = above limit; 1 = below or equal to limit. ● %I+27 = Channel No. 10 ALARM HI: 0 = below limit; 1 = above or equal to limit. ● %I+28 = Channel No. 11 ALARM LO: 0 = above limit; 1 = below or equal to limit. ● %I+29 = Channel No. 11 ALARM HI: 0 = below limit; 1 = above or equal to limit. ● %I+30 = Channel No. 12 ALARM LO: 0 = above limit; 1 = below or equal to limit. ● %I+31 = Channel No. 12 ALARM HI: 0 = below limit; 1 = above or equal to limit. 	

Table 10–9. Parameter Descriptions for Configuration (continued)

Parameter	Description
%I Size (cont'd)	<p><u>Fifth eight %I locations:</u> (available for %I SIZE value 40)</p> <ul style="list-style-type: none"> ● %I+32 = Channel No. 13 ALARM LO 0 = above limit; 1 = below or equal to limit. ● %I+33 = Channel No. 13 ALARM HI: 0 = below limit; 1 = above or equal to limit. ● %I+34 = Channel No. 14 ALARM LO: 0 = above limit; 1 = below or equal to limit. ● %I+35 = Channel No. 14 ALARM HI: 0 = below limit; 1 = above or equal to limit. ● %I+36 = Channel No. 15 ALARM LO: 0 = above limit; 1 = below or equal to limit. ● %I+37 = Channel No. 15 ALARM HI: 0 = below limit; 1 = above or equal to limit. ● %I+38 = Channel No. 16 ALARM LO: 0 = above limit; 1 = below or equal to limit. ● %I+39 = Channel No. 16 ALARM HI: 0 = below limit; 1 = above or equal to limit.
Range	<p>Select the type of input range and the ranges. Choices are 4 -20mA,* 0-20mA, or 4-20mA+. In the 4 to 20mA default range, input current values ranging from 4 to 20mA report 0 to 32,000 integer values to the CPU. In the 0 to 20mA range, input current values ranging from 0 to 20mA report 0 to 32,000 integer values to the CPU over an input current range of 0 to 20mA. The enhanced 4 to 20mA range operates like the default 4 to 20mA range, except that negative values are reported when the input current drops below 4mA. In this mode, if 0mA is input, the value reported to the PLC is -8,000.</p>
Alarm Low	<p>Enter a value that causes an alarm low indication to be passed to the PLC. Each channel has a low limit alarm value (ALARM LO), which causes %I points to be set. Values entered without a sign are assumed to be positive. Value checking should be done to determine if the alarm low values are allowed for the appropriate range. The values allowed are:</p> <ul style="list-style-type: none"> ● 4 to 20mA Range = 0 to 32759 ● 0 to 20mA Range = 0 to 32759 ● 4 to 20mA+ Range = -8,000 to +32759
Alarm High	<p>Enter a value that causes an alarm high indication to be passed to the PLC. Each channel has a high limit alarm value (ALARM HI), which causes %I points to be set. Values entered without a sign are assumed to be positive. Value checking should be done to determine if the alarm high values are allowed for the appropriate range. The values allowed are:</p> <ul style="list-style-type: none"> ● 4 to 20mA Range = 1 to 32760 ● 0 to 20mA Range = 1 to 32760 ● 4 to 20mA+ Range = -7999 to 32760

* Default selection.

6. Press Rack (Shift-F1) or the Escape key to return to the rack display.

Configuring IC693ALG223 Using Hand-Held Programmer

You can also configure the 16-Channel Analog Current Input module using the Series 90-30 Hand-Held Programmer. In addition to the information in this section, refer to GFK-0402, the *Hand-Held Programmer for Series 90-30/20/Micro Programmable Controllers User's Manual* for more information on configuration of Intelligent I/O modules.

Although you can change the number of actively scanned channels with the Logicmaster 90-30/20/Micro configurator function, the Hand-Held Programmer does not support editing the number of actively scanned channels. If the 16-Channel Analog Input module is initialized by a Hand-Held Programmer, the number of actively scanned channels is 16.

If a module had been previously configured with Logicmaster 90-30/20/Micro software and the number of actively scanned channels has been changed from 16, that number will be displayed on the bottom line of the Hand-Held Programmer display following the *AI*. You can edit data with the Hand-Held Programmer only for the active channels, but can not change the number of actively scanned channels.

Module Present

If a module is physically present in a system, it can be added to the system's configuration by *reading* the module into it. For example, assume that a 16-Channel Analog Current Input module is installed in slot 3 of a Model 311 PLC system. It can be added to the configuration with the following sequence. Use the Up and Down cursor keys or the # key to display the selected slot.

Initial Display

```
R0:03 EMPTY >S
```

To add the IC693ALG223 module to the configuration, press the **READ/VERIFY** key. The following screen will be displayed:

```
R0:03 HI-DEN C >S
I40:I_
```

Selecting %I Reference

At this point the starting %I reference address for the status data returned from the module must be entered. Notice that the length of the status field (**40**) is displayed as the first two digits following the first **I** on the second line of the display.

Note

This field cannot be changed with the Hand-Held programmer. However, it can be changed using the Logicmaster 90-30/20/20/Micro software configurator function. The Hand-Held Programmer will always reflect the currently active length of the status field.

Pressing the **ENT** key will allow the PLC to select the starting address of the status data. You can select a specific starting address by pressing the key sequence for the desired address and pressing the **ENT** key. For example to specify the starting address as I17, press the key sequence **1, 7, ENT**. The following screen will be displayed:

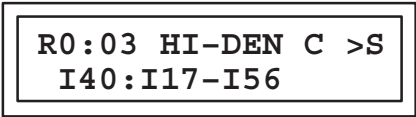

Selecting %AI Reference

After the starting %I address has been selected, pressing the **ENT** key again will cause the following screen to be displayed:



This screen allows you to select the starting address for the %AI reference. Note that the length of the status field (**16**) is displayed as the first two digits following the first **AI** on the second line of the display.

Note

This field cannot be changed with the Hand-Held programmer. However, it can be changed using the Logicmaster 90-30/20/Micro software configurator function. The Hand-Held Programmer will always reflect the currently active length of the status field.

In the AI field you can select the next available address (the default) by pressing the **ENT** key or by entering a specific address. To enter a specific address, press the starting reference number keys and the **ENT**. key (for example **3, 5**, then **ENT**).



You can press the **CLR** key at any time to abort the configuration you have just selected and return the slot to *EMPTY*.

Removing Module From Configuration

If required, this module can be removed from the current configuration. Assume that the module is currently configured in rack 0, slot 3. It can be deleted with the following sequence:

Initial Display

```
R0:03 HI-DEN C >S
AI16:AI_
```

To delete the module, press the **DEL**, **ENT** key sequence. The display will then be:

```
R0:03 EMPTY >S
```

Selecting Input Channel Ranges

The range for each of the 16 channels can be displayed and selected or changed as described below. Assume that the %AI address is as previously selected.

initial display

```
R0:03 HI-DEN C >S
AI16:AI035-AI051
```

To display the channel ranges press the **→** key. The display will show Channel 1 (or the currently selected channel) and the first available range.

```
R0:03 HI-DEN C >S
CHANNEL 1: 4-20
```

You can toggle through the range for each channel by pressing the **±** key. Each range will be displayed as shown. The range selected is the one currently displayed.

```
R0:03 HI-DEN C >S
CHANNEL 1: 0-20
```

```
R0:03 HI-DEN C >S
CHANNEL 1: 4-20+
```

Alarm Limits Display

To view the alarm limits for the channel currently displayed, press the **→** key again (the first time caused the channel ranges to be available for editing). The following screen is displayed:

```
R0:03 HI-DEN C >S  
CHAN 1 LO: 00000
```

The display is the entry field for the low alarm limit for the displayed channel (in this case, Channel 1). You can enter the desired low alarm limit value using the numeric keys and the ± key for specifying negative values. Enter the low alarm limit using a value within the valid limits as listed in Table 2. After you have entered the low alarm limit value, press the → key again to advance to the high alarm limit display for this channel. The following screen is displayed at this time.

```
R0:03 HI-DEN C >S  
CHAN 1 HI: 32000
```

The display shows the entry field for the high alarm limit for the currently displayed channel. You can enter positive or negative numbers (see table 2) using the ± and numeric keys. After selecting the low and high alarm limits for channel 1 (or the currently displayed channel), you can view the next channel by pressing the → key.

```
R0:03 HI-DEN C >S  
CHANNEL 2: 4-20
```

Edit the range, and low and high alarm limits as described for Channel 1. All active channels can be changed in this manner. Return to the initial display screen by pressing the ENT key or by pressing the ← key until the initial screen is displayed.

Saved Configurations

Configurations that contain a 16-Channel Analog Current Input module can be saved to an EEPROM or MEM card and read into the CPU at a later time. MEM cards and EEPROMs containing these configurations can be read into any Release 4 or later CPU. Refer to Chapter 2 of the *Hand-Held Programmer User's Manual* for detailed information on the Save and Restore operations.

IC693ACC223 Analog Module Field Wiring Connections

Connections to this module from user devices are made to screw terminals on a removable 20-terminal connector block mounted on the front of the module. The actual terminals used are described in the following table and are shown in the following wiring diagrams.

Terminal Assignments

Pin assignments for the 20 terminal I/O connector on the 16-Channel Analog Current Input module are as shown in the following table.

Table 10-10. Terminal Pin Assignments

Pin Number	Signal Name	Signal Definition
1	24VIN	User supplied 24V Input; provides loop power via 24VOUT terminal (pin 2)
2	24VOUT	+24V loop power tie point
3	CH1	Current Input, Channel 1
4	CH2	Current Input, Channel 2
5	CH3	Current Input, Channel 3
6	CH4	Current Input, Channel 4
7	CH5	Current Input, Channel 5
8	CH6	Current Input, Channel 6
9	CH7	Current Input, Channel 7
10	CH8	Current Input, Channel 8
11	CH9	Current Input, Channel 9
12	CH10	Current Input, Channel 10
13	CH11	Current Input, Channel 11
14	CH12	Current Input, Channel 12
15	CH13	Current Input, Channel 13
16	CH14	Current Input, Channel 14
17	CH15	Current Input, Channel 15
18	CH16	Current Input, Channel 16
19	COM	Common connection to input current sense resistors; user supplied 24V input return or 24VIN return
20	GND	Frame ground connections for cable shields

IC693ACC223 Analog Input Module Field Wiring Diagrams

The following figure provides information for connecting field wiring to the user terminal board on the 16-Channel Analog Current Input Module.

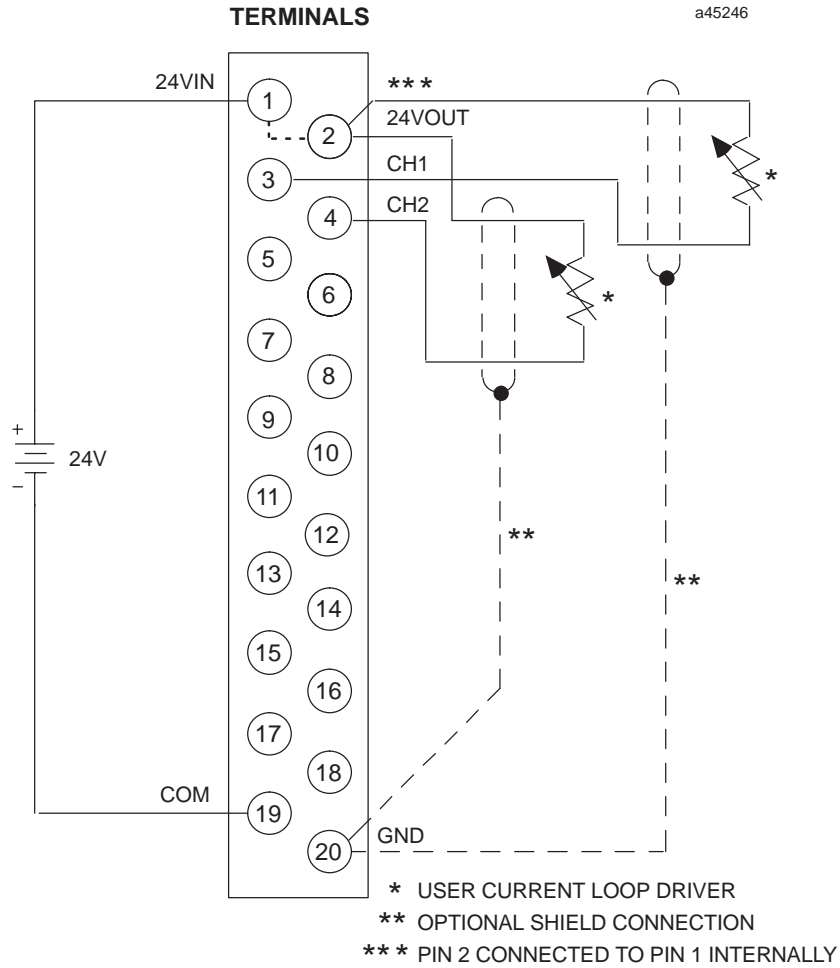

Figure 10-16. Field Wiring for 16-Channel Analog Current Input Module - IC693ALG223

Note

The current source may also be tied to the COM terminal if the source is floating to limit common-mode voltages. See the next figure.

Please refer to Chapter 2 for wiring and shield ground connection details.

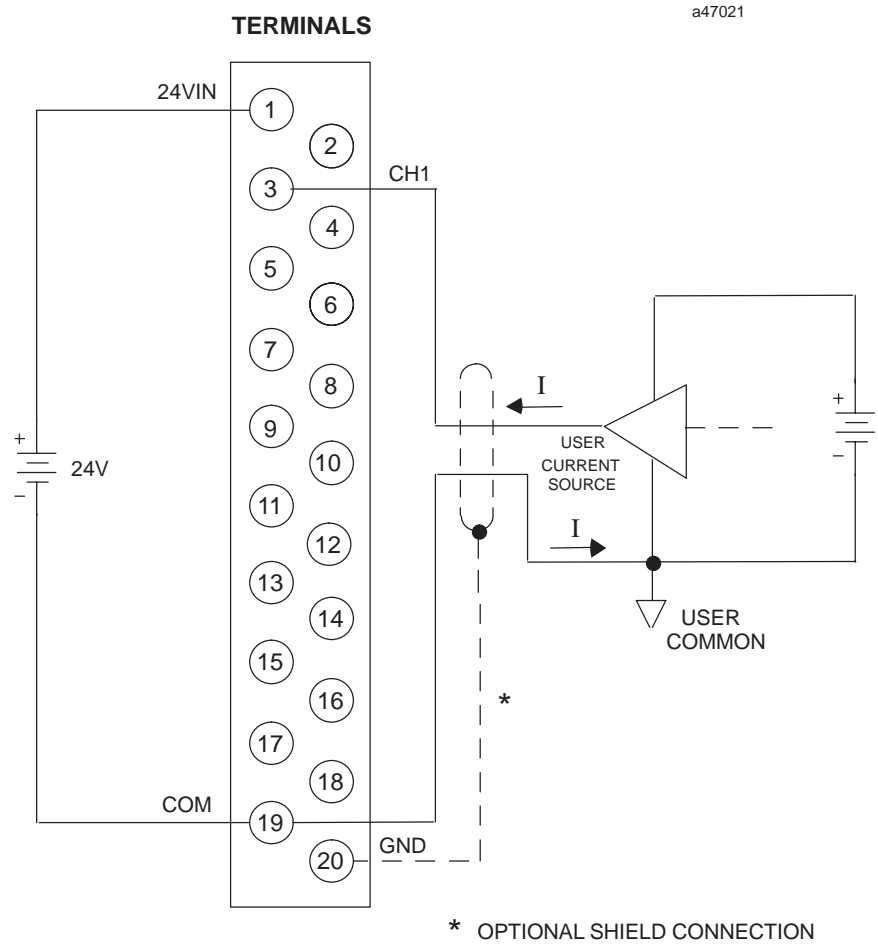

Figure 10-17. Field Wiring - Alternate User Connections - IC693ALG223

Note

Please refer to Chapter 2 for wiring and shield ground connection details.

IC693ACC223 Analog Current Input Block Diagram

The following figure is a block diagram of the 16-Channel Analog Current Input Module.

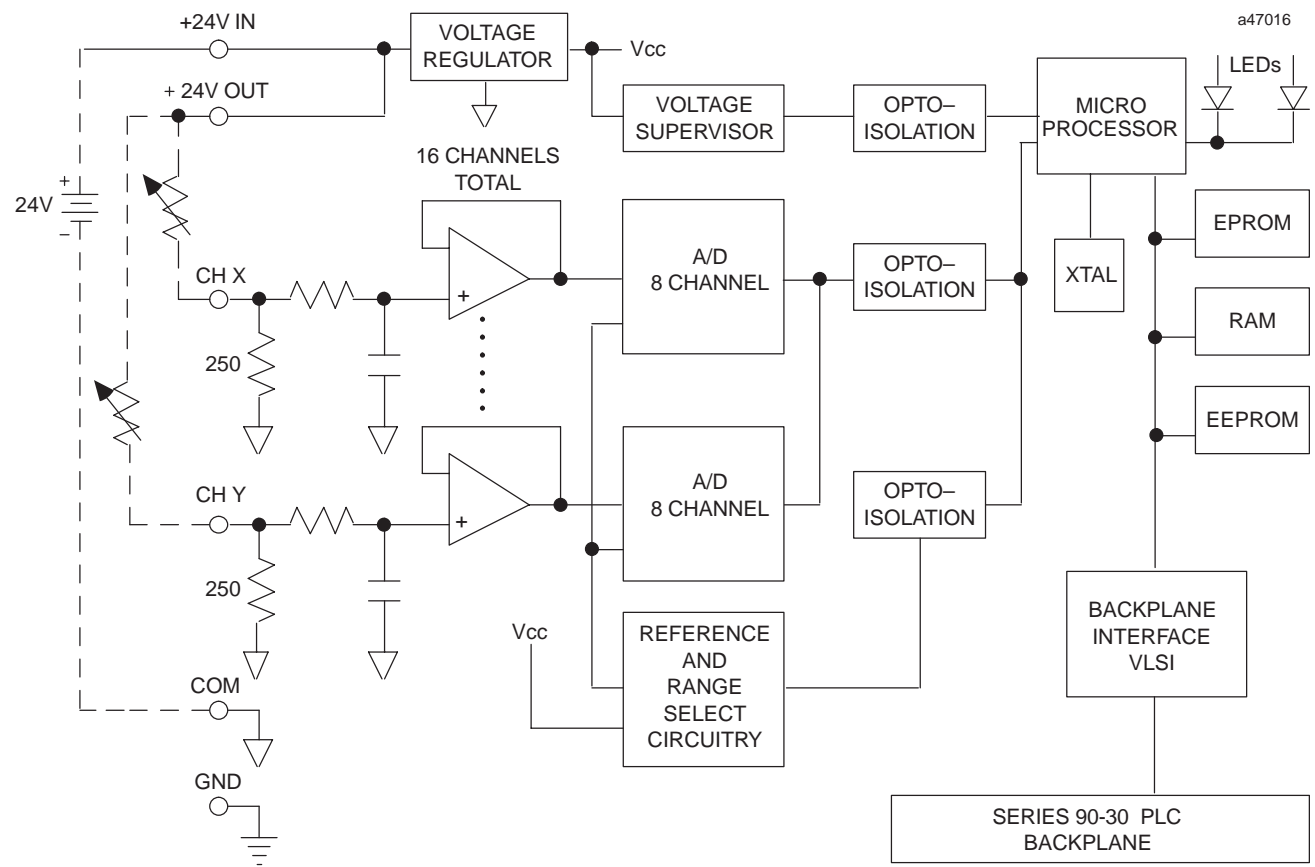

Figure 10-18. 16-Channel Analog Current Input Module Block Diagram - IC693ALG223

Analog Voltage Output - 2 Channel IC693ALG390

The *2-Channel Analog Voltage Output* module for the Series 90-30 Programmable Logic Controller provides two output channels, each capable of converting 13 bits of binary (digital) data to an analog output for use as required by your application. The Analog Voltage Output module is capable of providing outputs in the range of -10 to $+10$ volts. Resolution of the converted signal is 12 bits binary plus sign which is effectively 13 bits (1 part in 8192). Both channels are updated on every scan (about 5 milliseconds). User data in the %AQ registers is in a 16-bit 2's complement format. The 13 most significant bits from the %AQ register are converted to sign magnitude by the PLC and sent to the module for use by the D/A converter circuitry. The placement of the 13 bits converted to sign magnitude is shown below. The relationship between the voltage output and the data from the D/A converter is shown in Figure 3-30.

MSB													LSB		
S	D11	D10	D9	D8	D7	D6	D5	D4	D3	D2	D1	D0	X	X	X

S = Sign bit.

X = not applicable to this discussion.

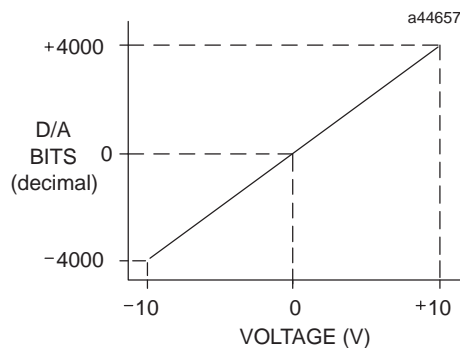

Figure 11-1. D/A Bits vs. Voltage Output

The state of the module, if the CPU goes to the STOP mode or RESET, can be either *Default to 0 volts* or *Hold-Last-State*. Selection of the desired state is made by configuring the DEF0 jumper on the detachable terminal connector on the module. If the jumper is not installed, the outputs will Hold-Last-State on STOP or RESET. Scaling of the output is shown below.

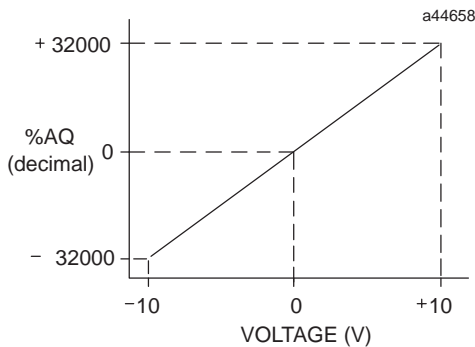

Figure 11-2. Scaling for Voltage Output

The primary power source for the module is the isolated +24 VDC power supplied by the PLC power supply. Two terminals are provided on the module’s terminal connector for user supplied +24 volts. This allows you to provide a standby power supply, so that the outputs can continue to hold their value if the internal supply is lost and Hold Last State is selected. Additionally, you can also supply the module voltage to reduce the load on the PLC isolated +24 VDC power supply. The user supply must be used when the applied voltage is 0.7 volts higher than the isolated +24 VDC supply, which can range from 21.5 volts to 26.5 volts. An LED at the top of the module’s faceplate is ON when the module’s power supply is operating.

To minimize capacitive loading and noise, all field connections should be wired using a good grade of twisted, shielded instrumentation cable. The shields should be connected to GND on the user terminal connector block. The GND connection provides access to the baseplate (frame ground) resulting in superior rejection of noise caused by any shield drain currents.

The module provides electrical isolation of externally generated noise between field wiring and the backplane through the use of optical isolation. This module can be installed in any I/O slot of a 5 or 10-slot baseplate in a Series 90-30 PLC system. Refer to page 3-11 to determine the number of Analog Voltage Output modules that can be installed in a system.

Table 11-1. Specifications for Analog Voltage Output Module, IC693ALG390

Voltage Range	-10 to +10 volts
Calibration	Factory calibrated to 2.5 mV per count
Supply Voltage (nominal)	+24 VDC, from isolated +24 VDC on backplane or user supplied voltage source, and +5 VDC from backplane
External Supply Voltage Range	18 to 30 VDC
External Supply Voltage Ripple	10%
Update Rate	5 msec (both channels) <i>This update rate is approximate since it is determined by I/O scan time, and is application dependent.</i>
Resolution	2.5 mV (1 LSB = 2.5 mV)
Absolute Accuracy †	± 5 mV at 25° C (77° F)
Offset	1 mv maximum, 0 to 60° C (32° to 140° F)
Output Loading (maximum)	5 mA (2K ohms minimum resistance)
Output Load Capacitance	2000 pico farads, maximum
Isolation	1500 volts between field side and logic side
Internal Power Consumption	32 mA from +5 volt supply 120 mA from +24 volt supply (isolated backplane or user supply)

Refer to Appendix B for product standards and general specifications.

† In the presence of severe RF interference (IEC 801-3, 10V/m), accuracy may be degraded to ±50mV.

IC693ALG390 Analog Voltage Output Block Diagram

The following figure is a block diagram of the 2-Channel Analog Voltage Output Module, IC693ALG390.

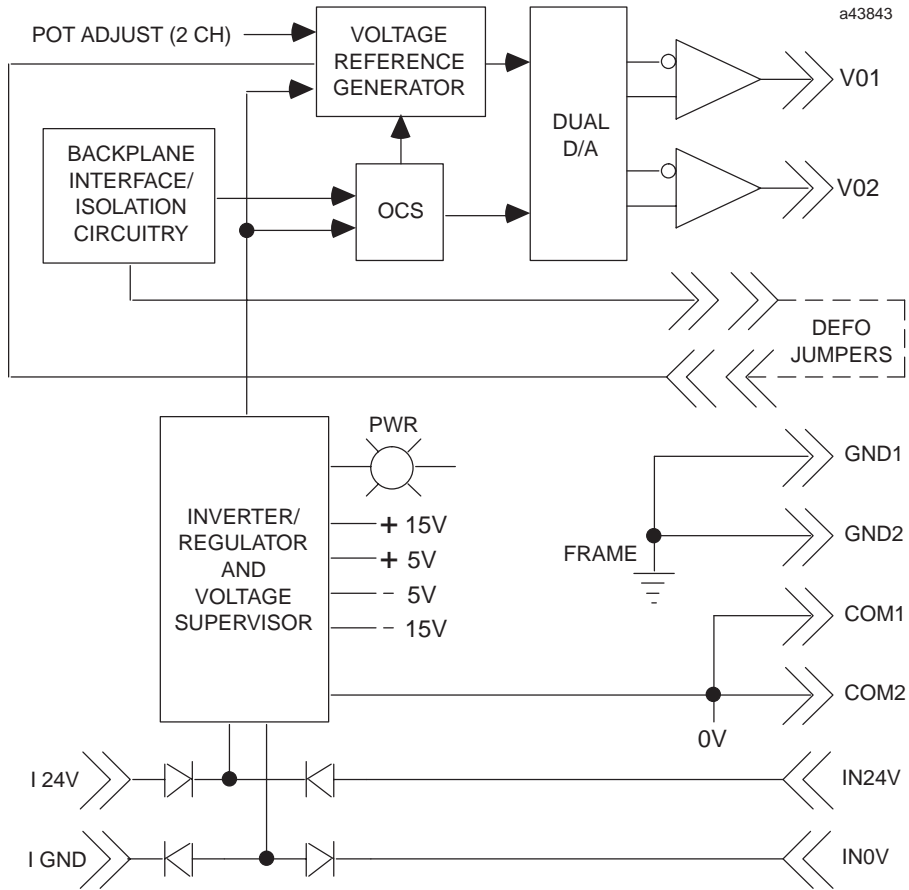

Figure 11-3. Analog Voltage Output Module Block Diagram - IC693ALG390

IC693ALG390 Analog Output Module Field Wiring Diagram

The following figure provides information for connecting field wiring to the Analog Voltage Output module.

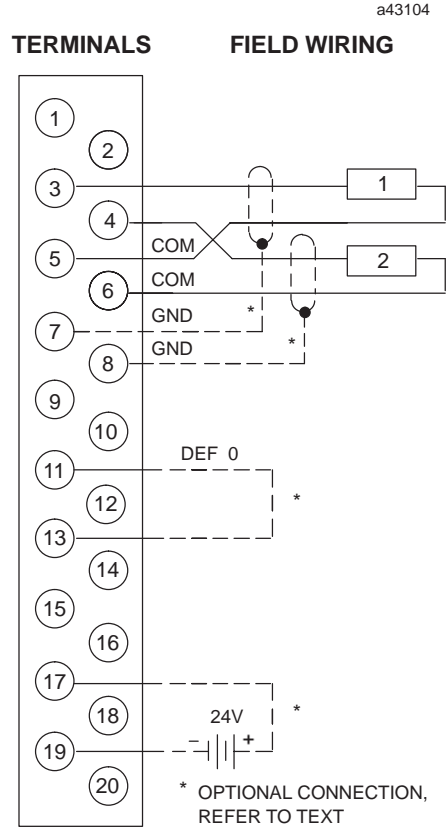

Figure 11-4. Field Wiring for Analog Voltage Output Module - IC693ALG390

Note

Please refer to Chapter 2 for wiring and shield ground connection details.

Analog Current Output - 2 Channel IC693ALG391

The **2-Channel Analog Current Output** module for the Series 90-30 Programmable Logic Controller provides two output channels, each capable of converting 12 bits of binary (digital) data to an analog output for use as required by your application. The Analog Current Output module is capable of providing outputs in the range of 0 to 20 mA. Resolution of the converted signal is 12 bits binary (1 part in 4096). The sign bit is not used in the conversion process. Both channels are updated on every scan (about 5 milliseconds). User data in the %AQ registers is in a 16-bit 2's complement format. The 13 most significant bits from the %AQ register are converted to sign magnitude by the PLC and sent to the module. Twelve of the bits are used by the D/A converter; the 13th bit (sign) is used to determine if negative data was sent to the module.

The placement of the 13 bits within the data word is shown below. The relationship between the current output and the data from the D/A converter is shown in Figures 3-34 and 3-35.

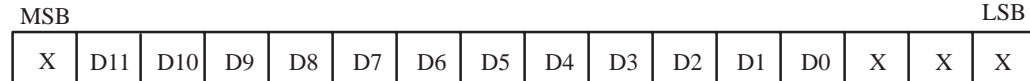

S = sign bits

X = not applicable to this discussion.

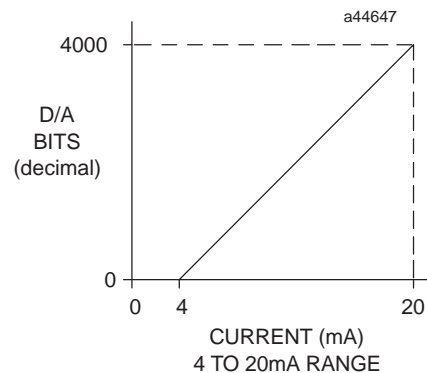

Figure 11-5. D/A Bits vs. Current Output, 4 to 20 mA

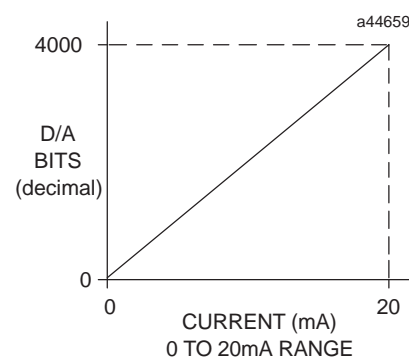

Figure 11-6. D/A Bits vs. Current Output, 0 to 20 mA

If the module is sent negative data, it outputs the low end of the current range (that is, 4 mA for the 4 to 20 mA range). If a value which is out of range is entered (that is, greater than 32767), the software does not accept the value.

This module provides two output ranges. The default range is 4 to 20 mA with user data scaled so that a count of 0 corresponds to 4 mA and a count of 32000 corresponds to 20 mA with each 1000 counts representing 0.5 mA. When a RANGE jumper (either RANGE1 or RANGE2) is added to the I/O terminal board, the output range is 0 to 20 mA with user data scaled so that a count of 0 corresponds to 0 mA and a count of 32000 corresponds to 20 mA with each 800 counts representing 0.5 mA. The range of each output can be programmed individually. The module provides a full 12 bits of resolution in either range. Scaling of the output is as shown in Figures 3-36 and 3-37.

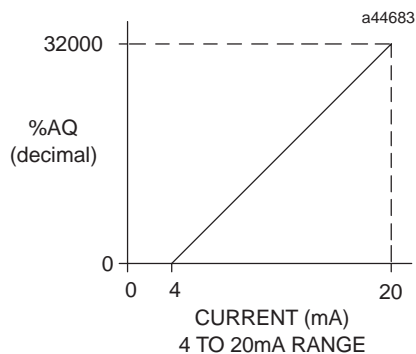

Figure 11-7. Scaling for Current Output, 4 to 20 mA

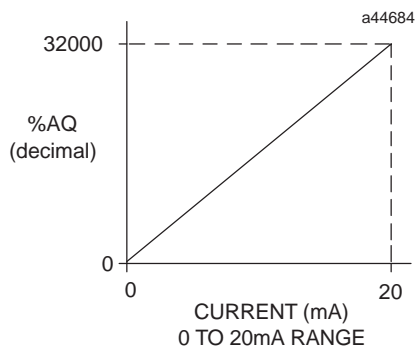

Figure 11-8. Scaling for Current Output, 0 to 20 mA

The state of the module if the CPU goes to the STOP mode or RESET, can be either *Default to 0/4 mA* or *Hold-Last-State*. Selection of the desired state is made by configuring the DEF0/4 jumper on the detachable terminal board connector on the module. If the jumper is not installed, the outputs will Hold-Last-State on STOP or RESET provided that a backup user supply is connected when the system power goes down. If the DEF0/4 jumper is present, the module defaults to 4 mA on the 4 to 20 mA range or 0 mA on the 0 to 20 mA range on STOP or RESET. One jumper per module is used to program both outputs for Hold-Last-State or DEF0/4.

Each module output may be used as a current source or as a less accurate voltage source. A voltage is output at VOUTx that corresponds to the current output. The selection of current or voltage output is made with a jumper on the I/O terminal board. If no jumper is installed, the module performs as a current source. If the JMPVx jumper is present, the module performs as a voltage source. Each channel has the option of selecting voltage or current. The setting of the current output range determines the voltage range. The voltage range can be increased by using a 250 ohm resistor in place of the voltage jumper from JMPVx to IOUTx. The following table shows the relationship between range settings and voltage outputs.

Table 11-2. Range Settings vs. Voltage Outputs

Range Setting	Voltage Range
4 to 20 mA (no range jumper)	1 to 5 V 2 to 10 V with external resistor
0 to 20 mA (range jumper present)	0 to 5 V 0 to 10 V with external resistor

The primary power source for the module is the isolated +24 VDC power supplied by the PLC power supply. Two terminals are also provided on the module's I/O terminal board for user supplied +24 volts. This allows you to provide a standby power supply so that the outputs can continue to hold their value if the internal supply is lost and Hold-Last-State is selected. You may also want to supply the module voltage to reduce the load on the PLC isolated +24 VDC power supply. The user supply will be used when the applied voltage is higher than the isolated +24 VDC supply, which can range from 21.5 volts to 26.5 volts.

An internal voltage source of about +24V is generated in the module to drive the current loop outputs. The current loop drivers on the module are source type drivers. This means that a positive current flows out of the current loop outputs so that the user's loads can be returned to common. A resistor is placed in series with the common return to limit ground loop currents. To minimize the

capacitive loading and noise, all field connections to the module should be wired using a good grade of twisted, shielded instrumentation cable. The shields should be connected to GND on the user terminal connector block. The GND connection provides access to the baseplate (frame ground) resulting in superior rejection of noise caused by any shield drain currents.

An LED on the module's faceplate is ON when the module's power supply is operating. The module provides electrical isolation of externally generated noise between field wiring and the backplane through use of optical isolation. This module can be installed in any I/O slot of a 5 or 10-slot baseplate in a Series 90-30 PLC system. If user provided supplies are not used to power the module, a maximum of three Analog Current Output modules can be installed in a baseplate.

Table 11-3. Specifications for Analog Current Output Module - IC693ALG391

Output Current Range	4 to 20 mA and 0 to 20 mA
Output Voltage Range ¹	1 to 5 V and 0 to 5 V
Calibration	Factory calibrated to 4µA per count
Supply Voltage (nominal)	+24 VDC, from isolated +24 VDC on backplane or user supplied voltage source, and +5 VDC from backplane
External Supply Voltage Range ²	20 to 30 VDC
External Supply Voltage Ripple	10%
Update Rate	5 msec (approximate, both channels) <i>Determined by I/O scan time, and is application dependent.</i>
Resolution:	
4 to 20 mA	4µA (1 LSB = 4µA)
0 to 20 mA	5µA (1 LSB = 5µA)
1 to 5 V	1 mV (1 LSB = 1 mV)
0 to 5 V	1.25 mV (1 LSB = 1.25 mV)
Absolute Accuracy: ³	
4 to 20 mA	±8µA at 25°C (77°F)
0 to 20 mA	±10µA at 25°C (77°F)
1 to 5 V	±50 mV at 25°C (77°F)
0 to 5 V	±50 mV at 25°C (77°F)
Maximum Compliance Voltage	25 V
User Load (current mode)	0 to 850 ohms
Output Load Capacitance (current mode)	2000 pF
Output Load Inductance (current mode)	1 H
Maximum Output Loading (voltage mode)	5 mA (2K ohms minimum resistance) (2000 pF maximum capacitance)
Isolation	1500 volts between field and logic side
Internal Power Consumption	30 mA from +5V supply 215 mA from Isolated +24 VDC backplane supply or user supply

Refer to Appendix B for product standards and general specifications.

¹ Allowable load on the voltage output option can be calculated from the total module current shown in Figure 3-38.

² Allowable user supply is dependent on the current load and the ambient temperature as shown in Figure 3-38.

³ In the presence of severe RF interference (IEC 801-3, 10V/m), accuracy may be degraded to ½ µA (4 to 20 mA range), ½ µA (0 to 20 mA range).

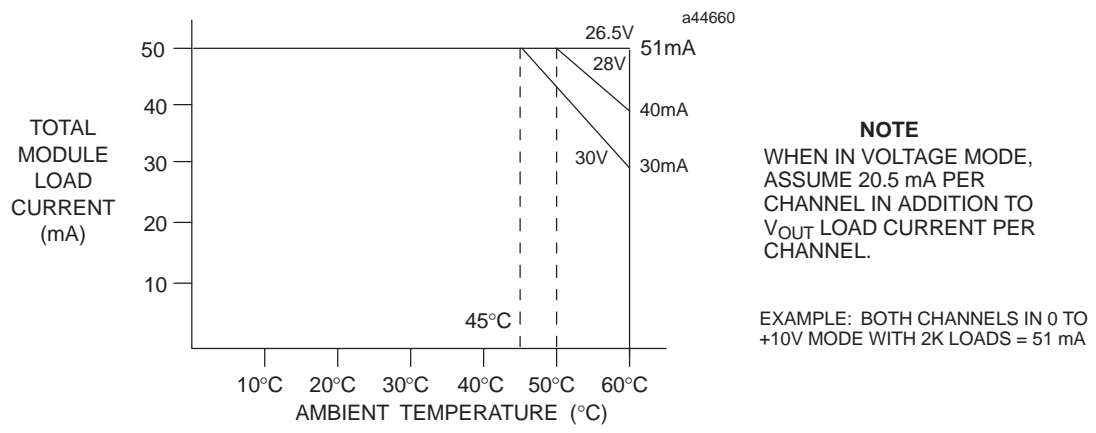

Figure 11-9. Load Current Derating

IC693ALG391 Analog Current Output Block Diagram

The following figure is a block diagram of the 2-channel Analog Output module.

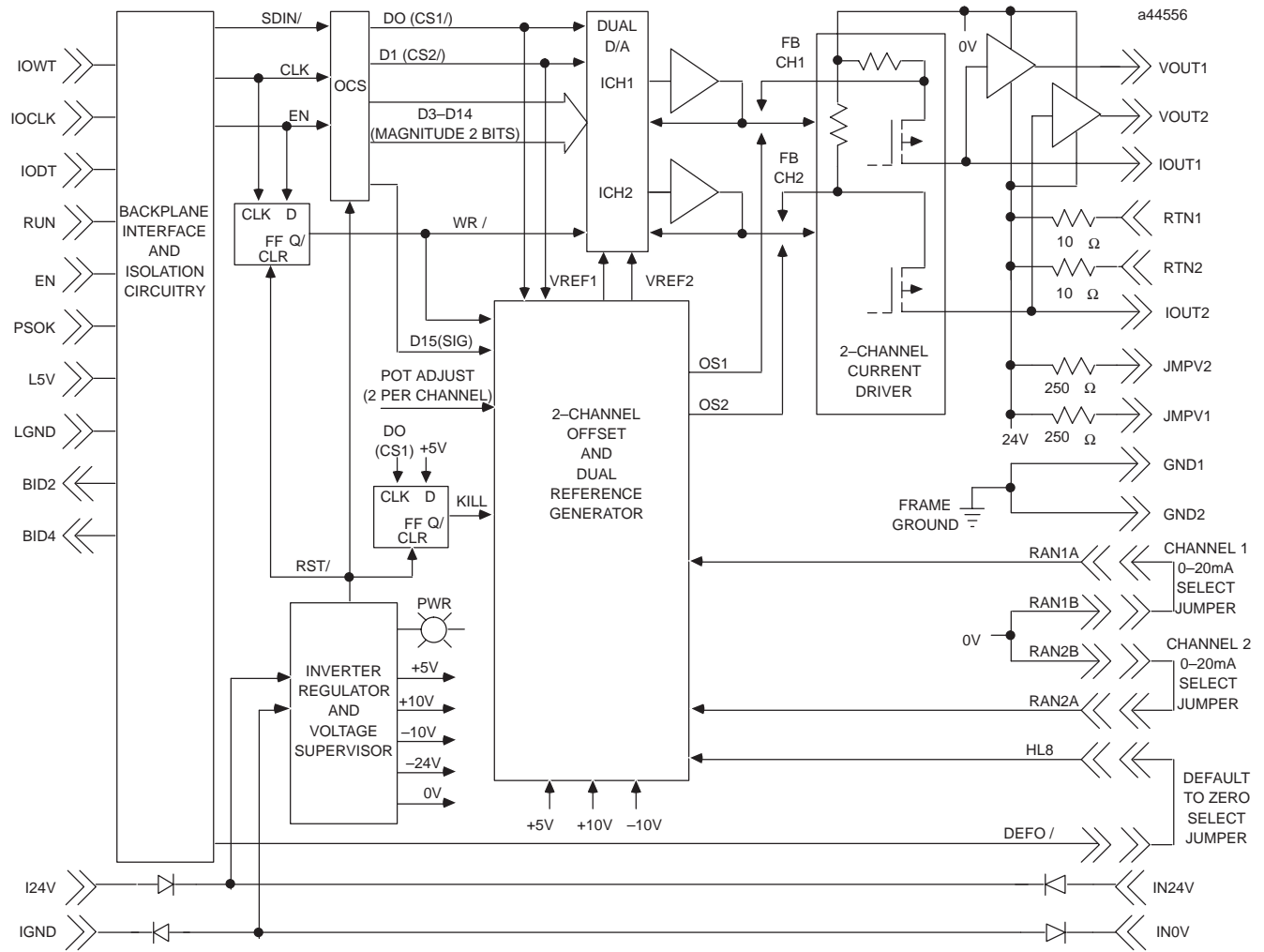

Figure 11-10. Analog Current Output Module Block Diagram - IC693ALG391

IC693ALG391 Analog Output Module Field Wiring Diagrams

The following two figures provide information for connecting field wiring to the Analog Current Output module. Figure 3-40 shows the connections necessary for the outputs to be used as analog current outputs.

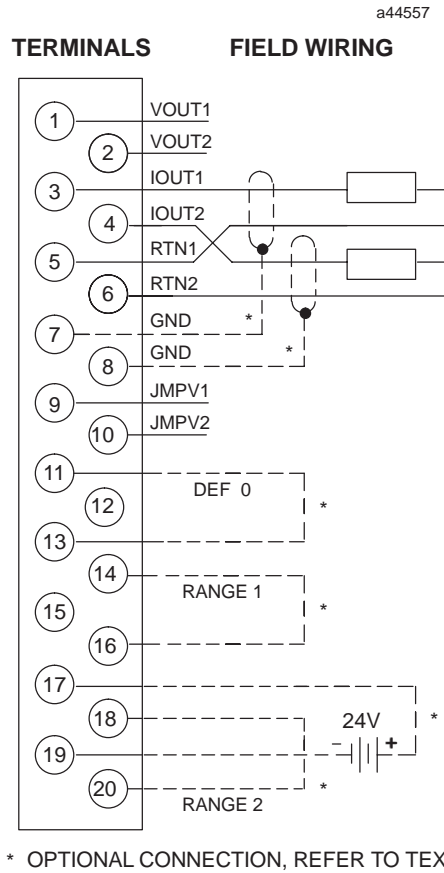

Figure 11-11. Field Wiring - Analog Current Output Module (Current Mode) - IC693ALG391

Note

An external supply can be used to power the module and the loop current.

Please refer to Chapter 2 for wiring and shield ground connection details.

Figure 3-41 shows the connections necessary for the outputs of the module to be used as analog voltage outputs.

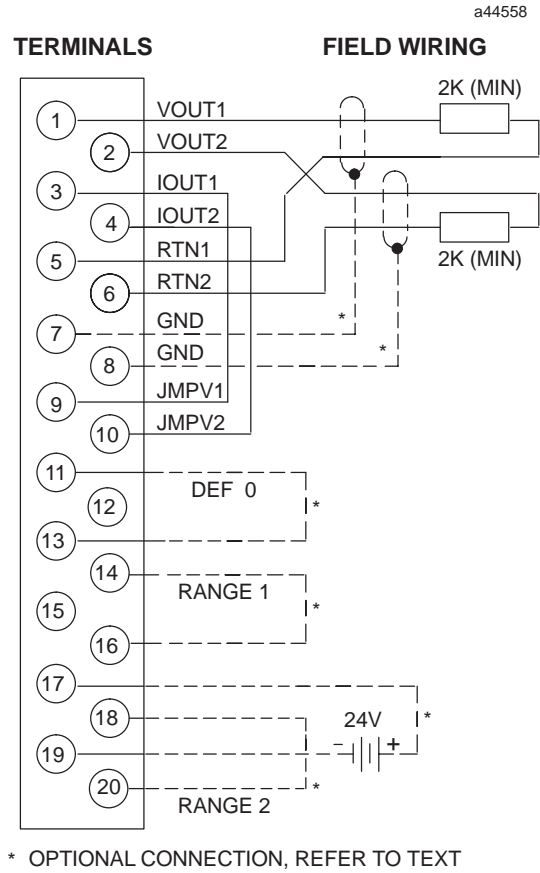

Figure 11-12. Field Wiring - Analog Current Output Module (Voltage Mode) - IC693ALG391

Note

Please refer to Chapter 2 for wiring and shield ground connection details.

Analog Current/Voltage Output - 8 Channel IC693ALG392

The *8-Channel Analog Current/Voltage Output* module provides up to eight single-ended output channels with current loop outputs or voltage outputs. Each analog output channel is capable of providing two current output ranges or two voltage output ranges. Each channel can be individually configured for the output range required for your application. The module has no jumpers or switches for configuration.

All ranges can be configured using either Logicmaster 90-30/20/Micro or CIMPLICITY Control Programming Software configurator function, or the Series 90-30 Hand-Held Programmer. The default range is 0 to +10 volts. Configurable current and voltage output ranges are:

- 0 to +10 volts (unipolar)
- -10 to +10 volts (bipolar)
- 0 to 20 milliamps
- 4 to 20 milliamps

Each channel is capable of converting 15 to 16 bits (depending on the range selected) of binary (digital) data to an analog output for use as required by your application. All eight channels are updated every 12 milliseconds. User data in the %AQ registers is in a 16-bit 2's complement format. In current modes, an *open-wire fault* is reported to the CPU for each channel. The module can go to a known last state when system power is interrupted. As long as user power is applied to the module, each output will maintain its last value, or reset to zero, as determined by how you have configured the module.

Important Product Information

Please note the following important product information. This version of the 8-Channel Analog Current/Voltage Output module requires the following product versions for compatibility:

CPU: Firmware Versions 3.3 to 4.6:

If your CPU has firmware version 3.3 to 4.6, you *must* select 16 %I bits at configuration. If this selection is not made, a *loss of module* fault will occur.

CPU: Firmware Version 5.0 or later:

If your CPU has firmware version 5.0, or later, then the %I configuration will accept 8 or 16 %I bits.

Logicmaster 90-30/20/Micro Software:

Version 5.00, or later, is required to configure the module using the Logicmaster 90-30/20/Micro software configuration function.

Control Software:

Version 2.00, or later, is required to configure the module using the Control software configuration function.

IC693ALG392 Current/Voltage Ranges and Output Modes

Current Operation

In the 4 to 20 mA range user data is scaled so that 4 mA corresponds to a count of 0 and 20 mA corresponds to a count of 32000. In the 0 to 20 mA range, user data is scaled so that 0 mA corresponds to a count of 0 and 20 mA corresponds to 32000. Note that in the 0 to 20 mA mode, you can enter a value up to 32767 which provides a maximum output of approximately 20.5 mA. Scaling of the current output for both the 4 to 20 mA range and the 0 to 20 mA range is shown below. In current mode the module also provides an open loop fault detect which is reported to the PLC in the %I table.

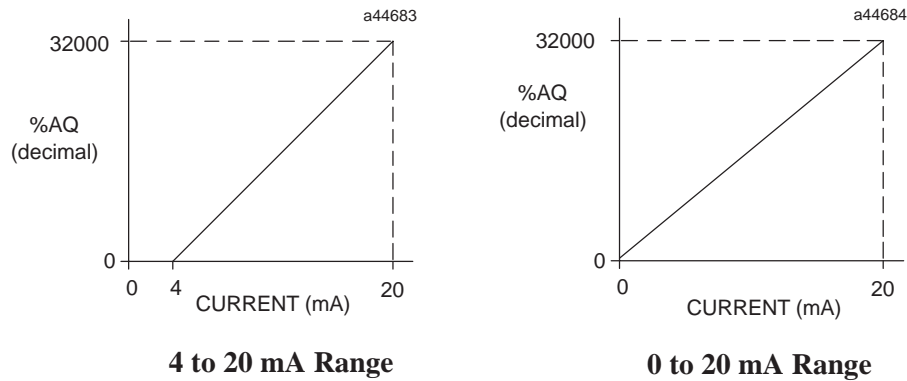

Figure 11-13. Scaling for Current Output

Voltage Operation

For *Voltage Operation* in the default unipolar mode (0 to +10 volts), user data is scaled so that 0 volts corresponds to a count of 0 and +10 volts corresponds to a count of 32000. In this mode, you can enter up to 32767 for an overrange of approximately 10.24 volts output. In the -10 to +10 volt range user data is scaled so that -10 volts corresponds to a count of -32000 and +10 volts corresponds to a count of +32000. In this range, you can enter -32767 to +32767 for an overrange of approximately -10.24 volts to +10.24 volts.

Scaling of the voltage output for both the 0 to +10 volt range and the -10 to +10 volt range is as shown in the following figure.

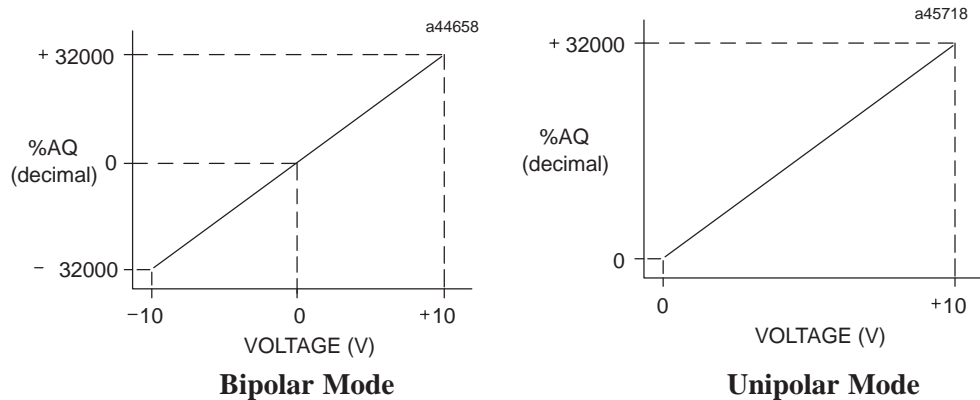

Figure 11-14. Scaling for Voltage Output

CPU Interface to the 8-Channel Analog Current/Voltage Output Module

The Series 90-30 PLC uses the data within the %AQ data table to record analog values for use by the programmable controller. This scheme for the 8-Channel Analog Current/Voltage Output module is shown below. More information on the CPU interface to analog modules can be found at the beginning of this chapter.

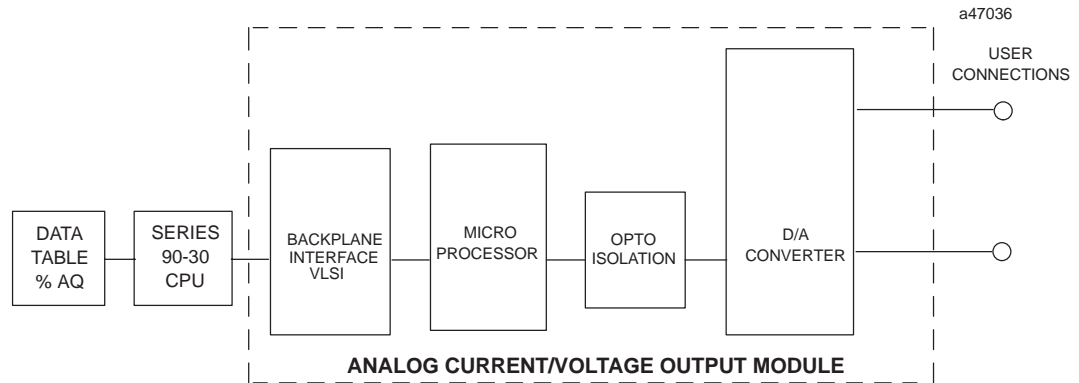

Figure 11-15. Basic Block Diagram for IC693ALG392

The following table summarizes the above information, including the module output range, user input data range, and the resolution of the selected range

Module Output Range	User Input Data Range	Resolution
4 to 20 mA	0 to 32000	15 bits
0 to 20.5 mA	0 to 32767	15 bits
0 to +10 volts	0 to 32767	15 bits
-10 to +10 volts	-32767 to +32767	16 bits

IC693ALG392 Field Wiring Connections

Connections to this module from user devices are made to screw terminals on a removable 20-terminal connector block mounted on the front of the module. The actual terminals used are described in the following table and are shown in the following wiring diagrams.

Terminal Assignments

Pin assignments for the 20 terminal I/O connector on the 8-Channel Analog Current/Voltage Output module are as shown in the following table.

Table 11-4. Terminal Pin Assignments for IC693ALG392

Pin Number	Signal Name	Signal Definition
1	24VIN	User Supplied +24 Volt Input
2	V CH 1	Channel 1 Voltage Output
3	I CH 1	Channel 1 Current Output
4	V CH 2	Channel 2 Voltage Output
5	I CH 2	Channel 2 Current output
6	V CH 3	Channel 3 Voltage Output
7	I CH 3	Channel 3 Current output
8	V CH 4	Channel 4 Voltage Output
9	I CH 4	Channel 4 Current output
10	V CH 5	Channel 5 Voltage Output
11	I CH 5	Channel 5 Current output
12	V CH 6	Channel 6 Voltage Output
13	I CH 6	Channel 6 Current output
14	V CH 7	Channel 7 Voltage Output
15	I CH 7	Channel 7 Current output
16	V CH 8	Channel 8 Voltage Output
17	I CH 8	Channel 8 Current output
18	V COM	Voltage Common
19	I COM	Current Common/User +24 Volt Return
20	GND	Frame ground connection for cable shields

IC693ALG392 Analog Output Module Field Wiring Diagram

The following figure provides information for connecting field wiring to the user terminal board on the 8-Channel Analog Current/Voltage Output Module.

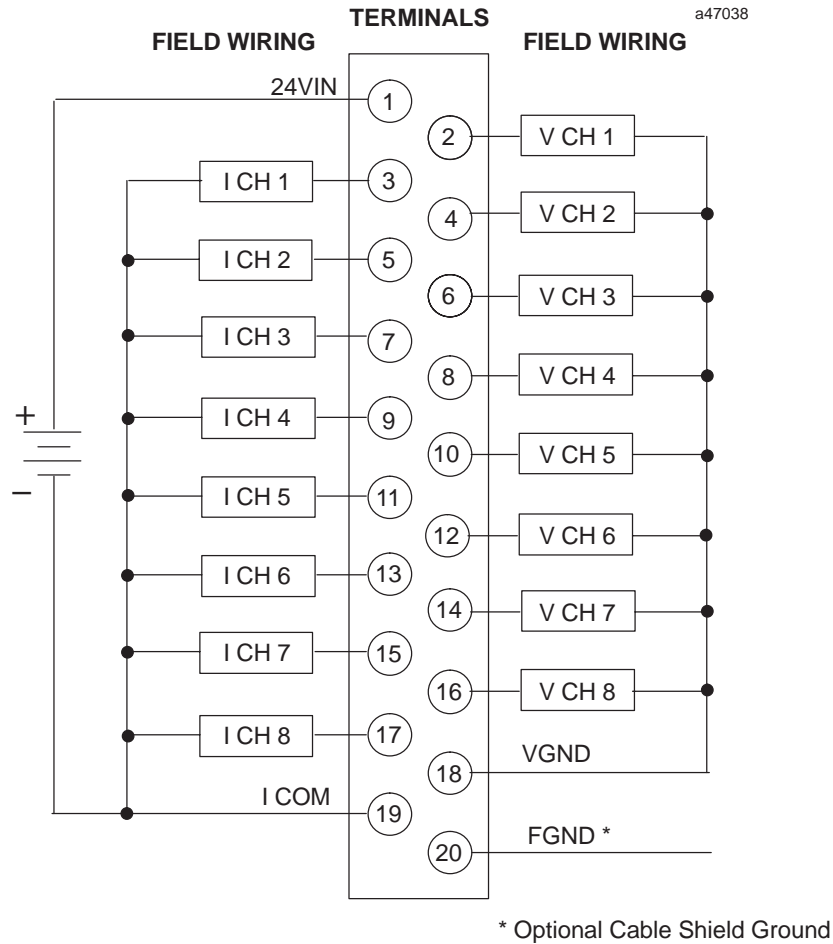

Figure 11-16. Field Wiring for 8-Channel Analog Current/Voltage Output Module, IC693ALG392

Note

Each channel can be configured independent of other channels to operate as a voltage output *or* a current output – *not both simultaneously*.

Please refer to Chapter 2 for wiring and shield ground connection details.

IC693ALG392 Status Reporting

The Analog Current/Voltage Output module provides status information to the PLC. This status information is updated once each PLC sweep and consists of three items:

- *health of the module* (all ranges)
- *overload or open wire detect* (current mode only)
- *status of the user-supplied power* to the module (all ranges)

IC693ALG392 Power Requirements and LEDs

This module requires a maximum of 110 mA from the 5V bus on the PLC backplane for the logic side. The module's analog power *must be supplied* by a user supplied single +24 VDC power source *and* requires a maximum current of 315 mA.

There are two green LED indicators on the module which provide module and user supply status. The top LED, **OK**, provides module status information and the bottom LED, **USOK**, indicates whether the user supply is present and is above a minimum designated level. Note that both LEDs are powered from the +5V backplane power bus.

The LEDs have six possible status combinations, which are described below.

LED Status Indications for IC693MDL392			
Combination	LED	Status	Description
1	OK	ON	Module OK and configured
	USOK	ON	User power is present
2	OK	FLASH	Module OK but not configured
	USOK	OFF	No user power
3	OK	FLASH	Module OK but not configured
	USOK	ON	User power is present
4	OK	ON	Module OK and configured
	USOK	OFF	No user power
5	OK	OFF	Module is defective or no +5V backplane power present
	USOK	OFF	User power may or may not be present
6	OK	OFF	Module not OK
	USOK	ON	User power is present

Location in System

This module can be installed in any I/O slot of a 5 or 10-slot baseplate in a Series 90-30 PLC system.

References Used

The number of 8-Channel Analog Current/Voltage Output modules which may be installed in a system depends on the amount of %AQ and %I references available. Each module uses 8 %AQ references (depending on the number of channels enabled) and 8 or 16 %I references (depending on *open wire detect* configuration).

There are 32 %AQ references available in a Model 311, Model 313, and Model 323 system, 64 %AQ references available in a Model 331 system, 256 %AQ references available in a Model 340 and Model 341 system, and 512 %AQ references available in a Model 351 and Model 352 system

The maximum number of 8-Channel Analog Current/Voltage Output modules that can be installed in a system are:

- 4 in a system using CPU Models 311, 313, or 323
- 8 in a system using CPU Model 331
- 32 in a system using CPU Models 340 and 341
- 64 in a system using CPU Models 350 – 364

Other Configuration Considerations

When planning the module configuration for your application you must also consider the load capacity of the installed power supply and the total load requirements of all modules that are installed in the baseplate.

Refer to Chapter 1 in this manual for details on power supply, baseplate, and module load requirements. The following table lists the specifications for this module. *Note that test conditions, unless otherwise noted, are: $V_{USER} = 24$ VDC at an ambient temperature of 25°C (77°F).*

Table 11-5. Specifications for IC693ALG392

Number of Output Channels	1 to 8 selectable, single-ended
Output Current Range	4 to 20 mA and 0 to 20 mA
Output Voltage Range	0 to 10 V and -10 to +10 V
Calibration	Factory calibrated to .625 μ A for 0 - 20 mA; 0.5 μ A for 4 - 20 mA; and .3125 mV for voltage (per count)
User Supply Voltage (nominal)	+24 VDC, from user supplied voltage source
External Supply Voltage Range	20 to 30 VDC
Power Supply Rejection Ratio (PSRR) ¹	
Current	5 μ A/V (typical), 10 μ A/V (maximum)
Voltage	25 mV/V (typical), 50 mV/V (maximum)
External Power Supply Voltage Ripple	10% (maximum)
Internal Supply Voltage	+5 VDC from PLC backplane
Update Rate	8 msec (approximate, all eight channels) <i>Determined by I/O scan time, and is application dependent.</i>
Resolution:	
4 to 20 mA	0.5 μ A (1 LSB = 0.5 μ A)
0 to 20 mA	.625 μ A (1 LSB = .625 μ A)
0 to 10 V	.3125 mV (1 LSB = .3125 mV)
-10 to +10 V	.3125 mV (1 LSB = .3125 mV)
Absolute Accuracy: ³	
Current Mode	\pm 0.1% of full scale @ 25°C (77°F), typical \pm 0.25% of full scale @ 25°C (77°F), maximum \pm 0.5% of full scale over operating temperature range (maximum)
Voltage Mode	\pm 0.25% of full scale @ 25°C (77°F), typical \pm 0.5% of full scale @ 25°C (77°F), maximum \pm 1.0% of full scale over operating temperature range (maximum)
Maximum Compliance Voltage	V _{USER} -3V (minimum) to V _{USER} (maximum)
User Load (current mode)	0 to 850 Ω (minimum at V _{USER} = 20V, maximum 1350 Ω at V _{USER} = 30V) ²
Output Load Capacitance (current mode)	2000 pF (maximum)
Output Load Inductance (current mode)	1 H
Output Loading (voltage mode)	5 mA (2K ohms minimum resistance)
Output load Capacitance	(1 μ F maximum capacitance)
Isolation	1500 volts between field and logic side
Internal Power Consumption	110 mA from +5V PLC backplane supply 315 mA from +24V user supply

Refer to Appendix C for product standards and general specifications.

¹ PSSR is measured by varying V_{USER} from 24V to 30V.

² Load less than 800 Ω is temperature dependent.

³ In the presence of severe RF interference (IEC 801-3, 10V/m), accuracy may be degraded to \pm 1% FS for current outputs and \pm 3% FS for voltage outputs.

Derating Curves for the 8 Channel Analog Output Module

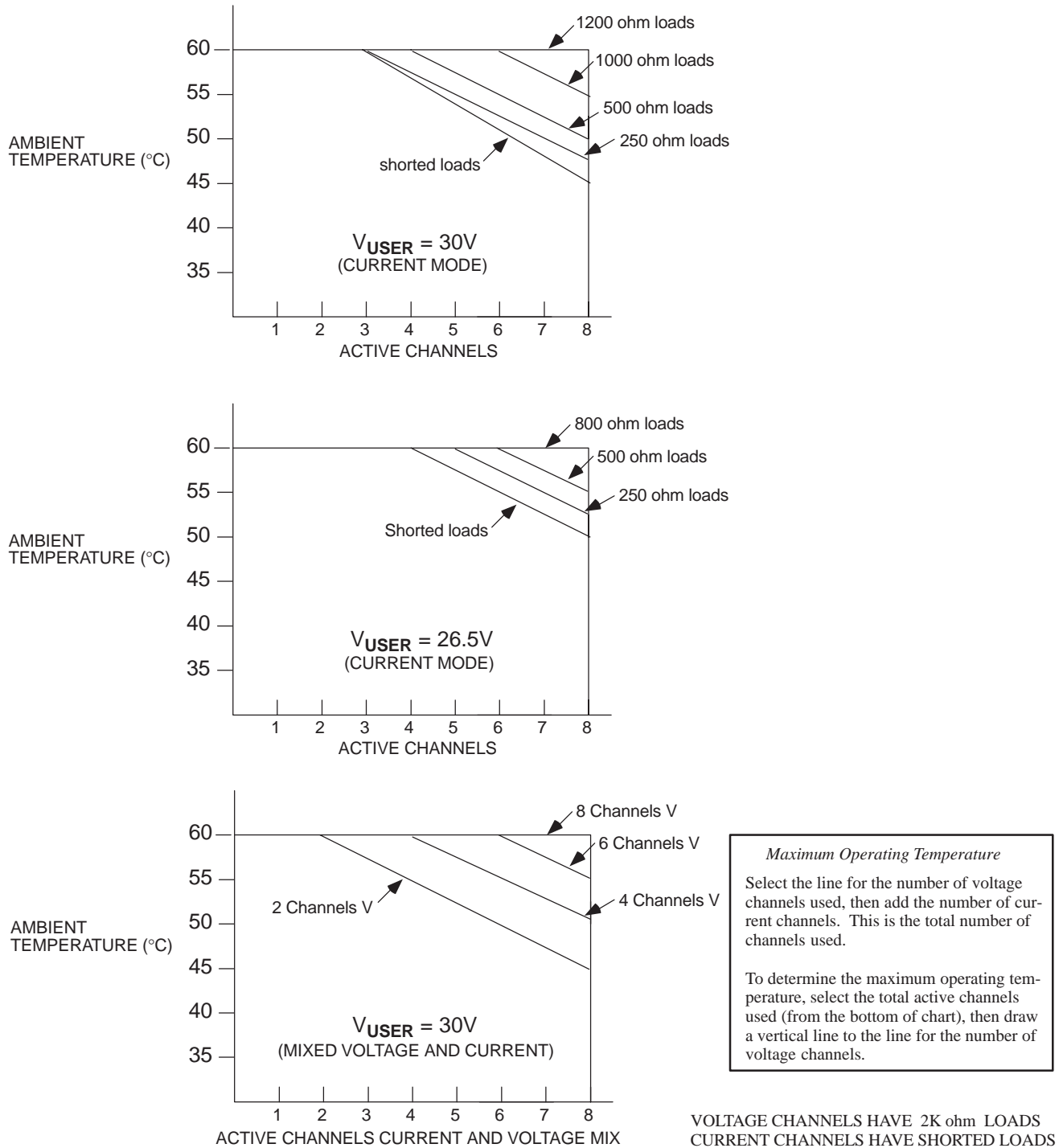

NOTE

For maximum performance and module life, it is recommended that the module be operated at maximum load resistance to offload heat from the module.

Figure 11-17. Module Derating Curves for IC693ALG392

Configuring the IC693ALG392 Analog Output Module

The 8-Channel Analog Current/Voltage Output module can be configured using the Logicmaster 90-30/20/Micro or CIMPLICITY Control Programming Software configurator function, or with the Hand-Held Programmer.

The parameters that can be configured are described in the following table. Configuration procedures using Logicmaster 90-30/20/Micro Programming Software and the Hand-Held Programmer are described in the following pages.

Table 11-6. Configuration Parameters for IC693ALG392

Parameter Name	Description	Values	Default Values	Units
<i>Active Channels</i>	Number of channels converted	1 through 8	1	n/a
<i>%AQ Address</i>	Starting address for %AQ reference type	standard range	%AQ0001, or next highest available address	n/a
<i>%I Address</i>	Starting address for %I reference type	standard range	%I00001, or next highest available address	n/a
<i>%I Size</i>	Number of %I status locations	8 or 16	8	bits
<i>STOP MODE</i>	Output state when module toggled from RUN to STOP mode	HOLD or DEFLOW	HOLD	n/a
<i>Range (Displayed under Stop Mode)</i>	Type of Output Range	0, +10V -10, +10V 4, 20 mA 0, 20 mA	0, 10V	n/a

For more information on configuration, see

- *Configuration Using Logicmaster 90-30/20/Micro Programming Software* beginning on page 3-72
- *Configuration Using the Hand-Held Programmer* beginning on page 3-76

Configuring IC693ALG392 Using Logicmaster Software

This section describes how to configure the 8-Channel Analog Current/Voltage Output module using the configurator function in Logicmaster 90-30/20/Micro Programming Software. *Configuration can also be done using CIMPLICITY Control Programming Software. For details refer to the CIMPLICITY Control online help.*

To configure an 8-Channel Analog Current/Voltage Output Module on the I/O Configuration Rack screen:

1. Move the cursor to the desired rack and slot location. The slot may be either unconfigured or previously configured.
2. Press the **1m30 io** key (**F1**). You will then see a screen similar to the following:

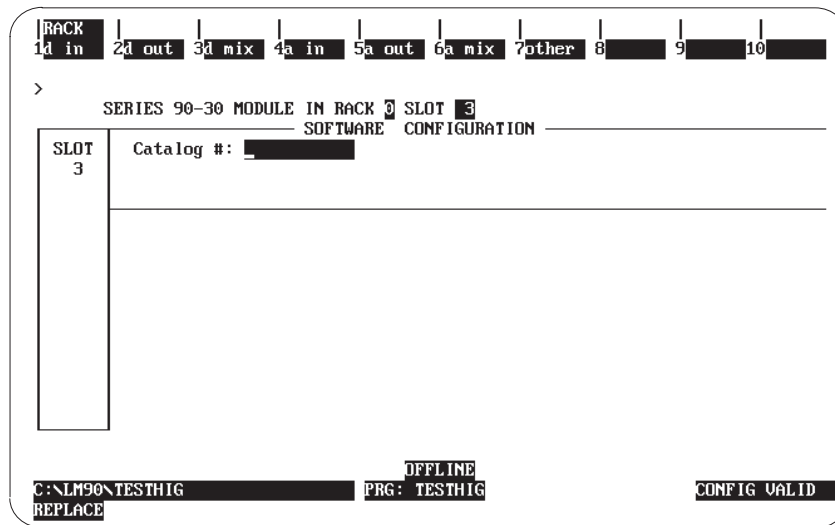

3. Press the **a out** key (**F5**). Your screen will now look like the one displayed below:

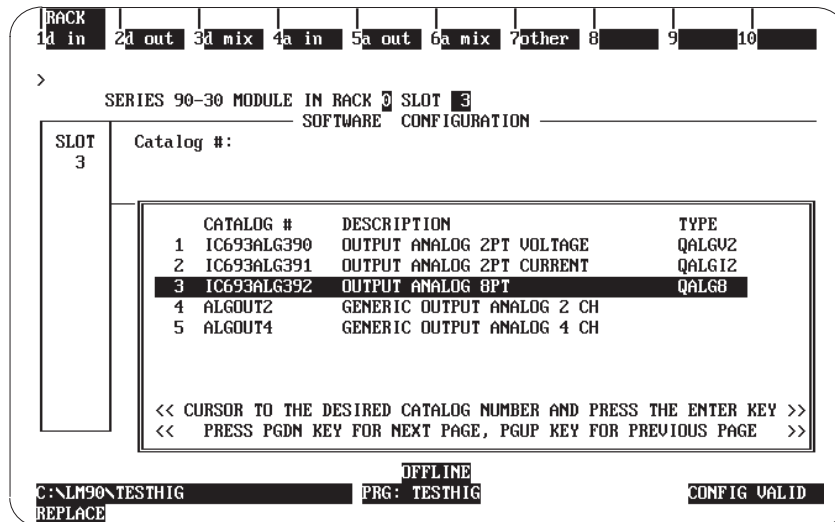

4. Move the cursor to the IC693ALG392 selection as shown above. Then press **Enter**.

The next screen that appears will look like the one displayed below:

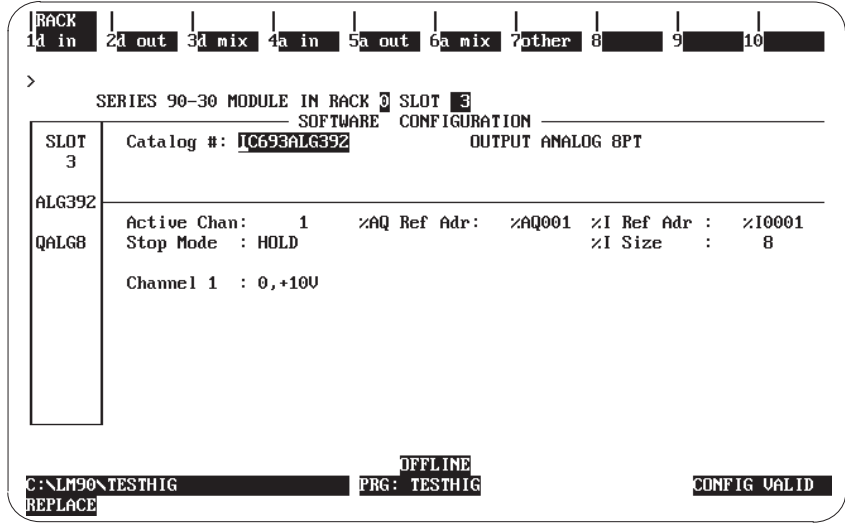

5. Enter the remaining configuration parameters on this screen. You can move your cursor from field to field by pressing the **Arrow** cursor control keys. When you are in the field you want to modify, you can either type in your choice or press the **Tab** key to scroll through the available selections (or **Shift-Tab** to reverse the direction of the selection list).

The default number of Active Channels (**Active Chan:**) is 1. You will not be able to configure additional channels until you change this field (by typing in the correct number (1 through 8) or by pressing the **Tab** key to increment the number). The screen displayed below shows the default selections after changing the **Active Chan:** field.

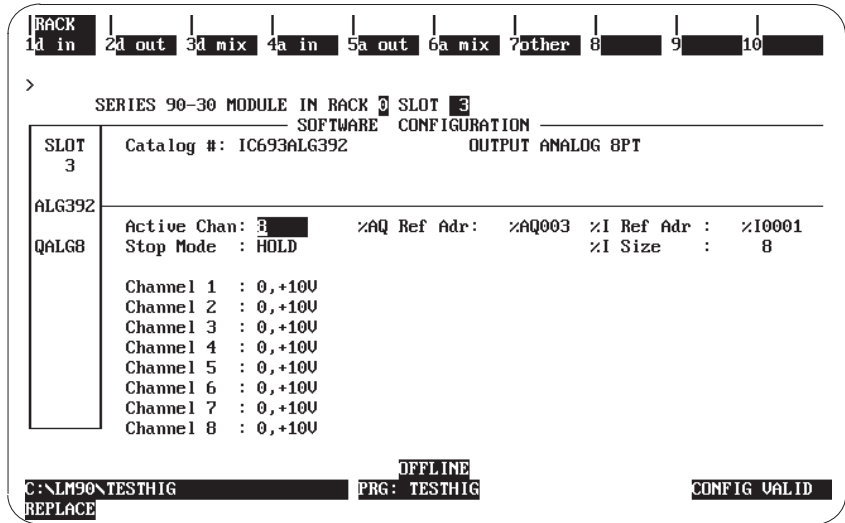

Note

The entry in the **Stop Mode** field (**HOLD** or **DEFLOW**) determines how the outputs will behave when the module is toggled from **RUN** to **STOP** mode. When this value is set to **HOLD** (the default), the outputs will retain their last state. When you change this value to **DEFLOW**, the output will go to zero.

Other Configuration Considerations for IC693ALG392

Channels are scanned in sequential, contiguous order with channel 1 being the first to be scanned. Note that the impact of the Current/Voltage Output module on the CPU scan time is directly proportional to the number of analog channels that you have enabled.

The only allowable entries for the **%AQ Ref Adr** are %AQ addresses. The only allowable entries for the **%I Ref Adr** are %I addresses.

The entry in **%I Size** will only accept 8 or 16. This field denotes the number of bits returned to the user.

The **%AQ Ref Adr** field is the reference address for the %AQ data and points to the start of the locations in the %AQ memory where the output data to the module begins. Each channel provides 16 bits of analog output data as an integer value from 0 to 32,760 or -32,767 to 32,752, depending on the range type selected. For detailed information on the data format, see the *CPU Interface to Analog Modules* section in this manual.

The **%I Ref Adr** is the reference address for the %I data and points to the start of the locations in the %I memory (the Input Table) where status information from the module is reported. You can select the number of %I status locations reported to the PLC by editing the value in the **%I Size** field. Values allowable in the %I Size field are 8 or 16, which refer to the number of %I locations reported to the PLC.

The **%I Ref Adr** field will only accept %I for %I Size values 8 or greater; the data brought back is in the format that follows:

The first eight %I locations (available for %I SIZE values 8, 16)

%I Locations	Description
%I	<i>Module OK</i> ; a 0 (zero) indicates NOT OK, 1 indicates module OK
%I+1	<i>User Supply OK</i> - Indicates when user supply is in specified limits; reads a 0 when user supply is below the specified limit, 1 when User supply is OK
%I+2 – %I+7	Reserved for future modules. Not used in this module.

Second eight locations – (available for %I SIZE value of 16)

%I Locations	Description
%I+8	Channel #1 BROKEN WIRE ; 0 = OK, 1 = Wire broken (I modes only)
%I+9	Channel #2 BROKEN WIRE ; 0 = OK, 1 = Wire broken (I modes only)
%I+10	Channel #3 BROKEN WIRE ; 0 = OK, 1 = Wire broken (I modes only)
%I+11	Channel #4 BROKEN WIRE ; 0 = OK, 1 = Wire broken (I modes only)
%I+12	Channel #5 BROKEN WIRE ; 0 = OK, 1 = Wire broken (I modes only)
%I+13	Channel #6 BROKEN WIRE ; 0 = OK, 1 = Wire broken (I modes only)
%I+14	Channel #7 BROKEN WIRE ; 0 = OK, 1 = Wire broken (I modes only)
%I+15	Channel #8 BROKEN WIRE ; 0 = OK, 1 = Wire broken (I modes only)

One of four output ranges can be selected. Two are voltage ranges. The default range is 0 to 10V, where output voltage values ranging from 0 to 10 volts correspond to 0 to 32000 integer values from the Series 90-30 CPU. The -10 to +10V range, when selected, corresponds from -32000 to 32000 from the CPU over an output voltage range of -10 to +10V. The two current ranges are 4 to 20 mA, and 0 to 20 mA. In each of the current ranges values between 0 and 32000 are sent to the module. Depending on which range is selected, will determine if the module is in Current or Voltage mode.

The following table shows values sent from the CPU to the module.

Range	Module Mode	*Allowed Values
0 to 10 V	Voltage	0 to 32767
-10 to 10 V	Voltage	- 32768 to 32767
4 to 20 mA	Current	0 to 32000*
0 to 20 mA	Current	0 to 32767

*Allowed values refers to the values that are valid. If a user sends a value > 32000, the module will truncate that value to 32000 before sending it to the D/A Converter.

Note

Only enabled (active) channels are displayed on the screen

6. Press **Shift-F1** (*Rack*) or the **Escape** key to return to the rack display.

Configuring IC693ALG392 with Hand-Held Programmer

You can also configure the 8-Channel Analog Current/Voltage Output module using the Series 90-30 Hand-Held Programmer. In addition to the information in this section, refer to GFK-0402, the *Hand-Held Programmer User's Manual* for more information on configuration of Intelligent I/O modules.

Although you can change the number of actively scanned channels with the Logicmaster 90-30/20/Micro configurator function, the Hand-Held Programmer does not support editing the number of actively scanned channels. If the 8-Channel Analog Current/Voltage Output module is initialized by a Hand-Held Programmer, the number of actively scanned channels is 8.

If a module had been previously configured with Logicmaster 90-30/20/Micro software and the number of actively scanned channels has been changed from 8, that number will be displayed on the bottom line of the Hand-Held Programmer display following the **AQ** entry. You can edit data with the Hand-Held Programmer only for the active channels, but you can not change the number of actively scanned channels.

Module Present

If a module is physically present in a system, it can be added to the system's configuration by reading the module into the configuration file. For example, assume that an 8-Channel Analog Current/Voltage Output module is installed in slot 3 of a Model 311 PLC system. It can be added to the configuration with the following sequence. Use the \uparrow and \downarrow arrow cursor keys or the # key to display the selected slot.

Initial Display

```
R0:03 EMPTY >S
```

To add the IC693ALG392 module to the configuration, press the **READ/VERIFY, ENT** key sequence. The following screen will be displayed:

```
R0:03 AO 1.00 >S
I16:I_
```

Selecting %I Reference

At this point the starting %I reference address for the status data returned from the module must be entered. Notice that the length of the status field (**16**) is displayed as the first two digits following the first **I** on the second line of the display.

Note

This field cannot be changed with the Hand-Held programmer. However, it can be changed using the Logicmaster 90-30/20/Micro software configurator function. The Hand-Held Programmer will always reflect the currently active length of the status field.

Pressing the **ENT** key will allow the PLC to select the starting address of the status data. You can select a specific starting address by pressing the key sequence for the desired address and pressing the **ENT** key. For example to specify the starting address as I17, press the key sequence **1, 7, ENT**. The following screen will be displayed:

```
R0:03 AO 1.00 >S
I16:I0017-I0032
```

You can press the **CLR** key at any time to abort the configuration you have just selected and return the slot to **EMPTY**.

After selecting the starting %I address and pressing the **ENT** key, the following screen appears.

```
R0:03 AO 1.00 >S
AQ8:AQ_
```

Selecting %AQ Reference

This screen allows you to select the starting address for the %AQ reference by specifying the starting reference in the %AQ field. You can select the next available address (the default) or enter a specific address. Pressing the **ENT** key will allow the PLC to select the starting addresses.

To enter a specific address (for example %AQ35), press the starting reference number keys and the **ENT** key. For example, to specify a starting address of %AQ35, press the key sequence **3, 5, ENT**.

```
R0:03 AO 1.00 >S
AQ8:AQ035-AQ043
```

Note that the length of the status field (**8**) is displayed as the first two digits following the first **AQ** on the second line of the display.

Note

This field cannot be changed with the Hand-Held programmer. However, it can be changed using the Logicmaster 90-30/20/Micro software configurator function. The Hand-Held Programmer will always reflect the currently active length of the status field.

You can press the **CLR** key at any time to abort the configuration you have just selected and return the slot to **EMPTY**.

Removing Module From Configuration

If required, this module can be removed from the current rack configuration. Assume that the module is currently configured in rack 0, slot 3. It can be deleted with the following sequence:

Initial Display

```
R0:03 AO 1.00 >S
AQ8:AQ_
```

To delete the module, press the **DEL**, **ENT** key sequence. The display will then be:

```
R0:03 EMPTY >S
```

If the **CLR** key had been pressed after the **DEL** key (instead of the **ENT** key), the delete operation would have been aborted.

Selecting Module Default Mode

The default STOP mode of the module, either HOLD or DEFLOW, can be displayed and modified, if required, by using the following procedure.

Initial Display

```
R0:03 AO 1.00 >S
I16:I0017-I0032
```

To display the module's default STOP mode, press $\rightarrow \rightarrow$. The display will show the current mode of the module. The default mode is **HOLD**.

```
R0:03 AO 1.00 >S
HLS/DEF:HOLD
```

You can toggle between the HOLD and DEFLOW modes by pressing the \pm key. The range selected is the one currently displayed.

```
R0:03 AO 1.00 >S
HLS/DEF:DEF LOW
```

When the desired mode for the module is displayed on the screen it can be accepted by pressing the **ENT** key. To return to the previous screen, press the \leftarrow key.

Selecting Output Channel Ranges

The range for each of the 8 channels can be displayed and selected or changed as described below. There are two current and two voltage ranges that can be selected.

Initial Display

```
R0:03 AO 1.00 >S
I16:I0017-I0032
```

To display the channel ranges press → → →. The display will show Channel 1 (or the currently selected channel) and the first available range.

```
R0:03 AO 1.00 >S
CHAN 1: 0 - 10 V
```

You can toggle through the range for each channel by pressing the ± key. Each range will be displayed as shown. Each of the ranges are shown below. The range that will be selected is the one currently displayed.

```
R0:03 AO 1.00 >S
CHAN 1: -10 - 10
```

```
R0:03 AO 1.00 >S
CHAN 1:4 - 20 MA
```

```
R0:03 AO 1.00 >S
CHAN 1:0 - 20 MA
```

When the desired range for the module is displayed on the screen it can be accepted by pressing the ENT key. To return to the previous screen, press the ← key. To view the next channel's range display, press the → key.

```
R0:03 AO 1.00 >S
CHAN 2: 0 - 10 V
```

Edit this channel's range the same as you did for the first channel. The range of all active channels can be changed in the same manner. Return to the initial display screen by pressing the ENT key or by pressing the ← key until the initial screen is displayed.

Saved Configurations

Configurations that contain an 8-Channel Analog Current/Voltage Output module can be saved to an EEPROM or MEM card and read from that device into the CPU at a later time. MEM cards and EEPROMs containing these configurations can be read into any Release 4 or later Series 90-30 CPU (cannot be read into a Series 90-20 CPU). Refer to Chapter 2 of the *Hand-Held Programmer User's Manual* for detailed information on the Save and Restore operations.

IC693ALG392 Analog Current/Voltage Output Block Diagram

The following figure is a block diagram of the 8-Channel Analog Current/Voltage Output Module.

a47037

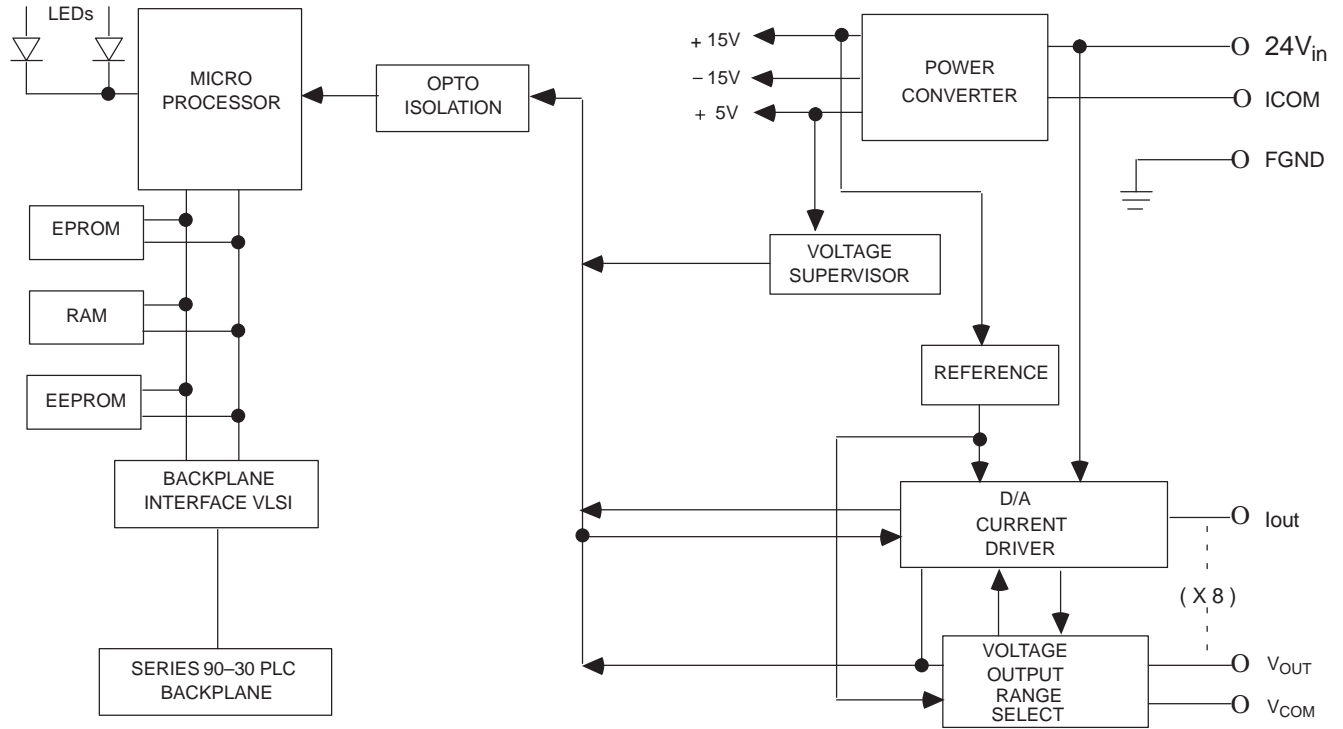

Figure 11-18. 8-Channel Analog Current/Voltage Output Module Block Diagram - IC693ALG392

Chapter 12

IC693ALG442 Analog Combination I/O Module

efesotomasyon.com

Analog Current/Voltage Combination Module 4 Input/2 Output Channels - IC693ALG442

The *Analog Current/Voltage Combination Input/Output* module provides up to 4 differential input current or voltage channels and 2 single-ended output channels with either current loop outputs or voltage outputs. Each channel can be individually configured for the current or voltage range, as applicable, required for your application. All module configuration is done through software, except for a jumper required for selecting the current input mode. All ranges can be configured using either the Logicmaster 90-30/20/Micro programming software configurator function or the Series 90-30 Hand-Held Programmer.

Note that in this module's description, the module will be simply referred to as the *Analog Combo Module*.

Each analog input is capable of providing five input ranges (two voltage and three current), which are:

- 0 to +10 volts (unipolar) - default range for both input and output channels.
- -10 to +10 volts (bipolar)
- 0 to 20 mA
- 4 to 20 mA
- 4 to 20 mA Enhanced

The default input range is voltage mode 0 to +10 volts (unipolar) with user data scaled so that 0V corresponds to a count of 0 and 10V corresponds to a count of 32767.

Each analog output is capable of providing four output ranges (two voltage and two current):

- 0 to +10 volts (unipolar) - default range for both input and output channels.
- -10 to +10 volts (bipolar)
- 0 to 20 milliamps
- 4 to 20 milliamps

Each output channel is capable of converting 15 to 16 bits (depending on the range selected) of binary (digital) data to an analog output for use as required by your application. User data in

the %AI and %AQ registers is in a 16-bit 2's complement format. In current modes, an *open-wire fault* is reported to the CPU for each channel. The module can go to a known last state when system power is interrupted. As long as user power is applied to the module, each output will maintain its last value, or reset to the low end of the scale (range), as determined by how you have configured the module.

Each output channel can be configured to operate in ramp mode using ladder logic. In ramp mode, changes in %AQ data cause the corresponding output channel to ramp to the new %AQ value. The ramp output consists of steps taken each millisecond until the final value is reached.

High and low alarm limits can be set for all input channels and an *open-wire fault* (current output modes) is reported to the CPU for each output channel. All six analog channels may be updated on every scan, depending on the scan time.

Table 12-1. Specifications for IC693ALG442

<u>Analog Output Specifications</u>	
Number of Output Channels	2, Single-Ended
Update Rate	4 milliseconds (approximate - both channels)
<u>Analog Current Output</u>	
Output Current Ranges	0 to 20 mA 4 to 20 mA
Resolution	
0 to 20 mA	0.625 μ A (1 LSB = 0.625 μ A)
4 to 20 mA	0.5 μ A (1 LSB = 0.5 μ A)
Absolute Accuracy¹	
All Current Modes	\pm 0.1% of full scale @25°C (77°F), typical \pm 0.25% of full scale @25°C (77°F), (maximum) \pm 0.5% of full scale over operating temperature range (maximum)
Maximum Compliance Voltage	V _{USER} -3V (minimum) to V _{USER} (maximum)
User Load	0 to 850 Ω (minimum) at V _{USER} =20V, maximum 1350 Ω at V _{USER} =30V
Output Load Capacitance	2000 pF (maximum)
Output Load Inductance	1 H (maximum)
<u>Analog Voltage Output</u>	
Output Ranges	-10 to +10V (bipolar) 0 to +10V (unipolar)
Resolution	
-10 to +10V	0.3125 mV (1 LSB = 0.3125 mV)
0 to +10V	0.3125 mV (1 LSB = 0.3125 mV)
Absolute Accuracy²	
Both Voltage Modes	\pm 0.25% of full scale @25°C (77°F), typical \pm 0.5% of full scale @25°C (77°F), (maximum) \pm 1.0% of full scale over operating temperature range (maximum)
Output Loading	5 mA (2K ohms minimum resistance)
Output Load Capacitance	1 μ F (maximum capacitance)
<u>Analog Input Specifications</u>	
Number of Input Channels	4, differential
Update Rate	8 milliseconds (approximate for all 4 channels)
<u>Analog Current Input</u>	

<p>Input Ranges</p> <p>(Continued from previous page)</p>	<p>0 to 20 mA 4 to 20 mA 4 to 20 mA Enhanced</p> <p style="text-align: right;">(Table continued on next page)</p>
<p>Resolution</p> <p>0 to 20 mA 4 to 20 mA 4 to 20 mA Enhanced</p> <p>Absolute Accuracy³ All Current Modes</p> <p>Linearity</p> <p>Common Mode Voltage</p> <p>Common Mode Rejection</p> <p>Cross Channel Rejection</p> <p>Input Impedance</p> <p>Input Filter Response</p>	<p>5 μA (1 LSB = 5 μA) 5 μA (1 LSB = 5 μA) 5 μA (1 LSB = 5 μA)</p> <p>± 0.25% of full scale @25°C (77°F) ± 0.5% of full scale over specified operating temperature range <1 LSB</p> <p>200V (maximum) >70 db at DC; >70 db at 60 Hz >80 db from DC to 1 kHz 250 Ω 29 Hz</p>
<p><i>Analog Voltage Input</i></p> <p>Input Ranges</p> <p>Resolution</p> <p>0 to +10V -10 to +10V</p> <p>Absolute Accuracy³ Both Voltage Ranges</p> <p>Linearity</p> <p>Common Mode Voltage</p> <p>Common Mode Rejection</p> <p>Cross Channel Rejection</p> <p>Input Impedance</p> <p>Input Filter Response</p>	<p>0 to +10V (unipolar) -10 to +10V (bipolar)</p> <p>2.5 mV (1 LSB = 2.5 mV) 5 mV (1 LSB = 5 mV)</p> <p>± 0.25% of full scale @25°C (77°F) ± 0.5% of full scale over specified operating temperature range <1 LSB</p> <p>200V (maximum) >70 db at DC; >70 db at 60 Hz >80 db from DC to 1 kHz 800K Ω (typical) 29 Hz</p>
<p><u>Power Requirements</u></p> <p>External Supply Voltage Range</p> <p>Power Supply Rejection Ratio (PSRR)⁴</p> <p>Current Voltage</p> <p>Voltage Ripple</p> <p>Current Consumption</p> <p>From Internal +5V Supply From External User Supply</p>	<p>20 to 30 VDC (24 VDC typical)</p> <p>5 μA/V (typical), 10μA/V (maximum) 25 mV/V (typical), 50mV/V (maximum)</p> <p>10%</p> <p>95 mA 129 mA</p>

¹In the presence of severe RF interference (IEC 801-3, 10V/m), accuracy may be degraded to ±1% FS.

²In the presence of severe RF interference (IEC 801-3, 10V/m), accuracy may be degraded to ±4% FS.

³In the presence of severe RF interference (IEC 801-3, 10V/m), accuracy may be degraded to ±2% FS.

⁴PSSR is measured by varying V_{USER} from 24V to 30V.

Refer to Appendix B for product standards and general specifications.

IC693ALG442 Input Modes and Current/Voltage Ranges

Current Operation

In the *4 to 20 mA range*, user data is scaled so that 4 mA corresponds to a count of 0 and 20 mA corresponds to a count of 32000. The other ranges are selected by changing the configuration parameters using the Logicmaster 90-30/20/Micro configurator software or the Hand-Held Programmer. In the *0 to 20 mA range* user data is scaled so that 0 mA corresponds to a count of 0 and 20 mA corresponds to a count of 32000. Full 12-bit resolution is available over the 0 to 20 mA range.

A *4 to 20 mA Enhanced range* can also be selected. When this range is selected, 0 mA corresponds to a count of -8000, 4 mA corresponds to a count of 0 (zero) and 20 mA corresponds to a count of +32000. The Enhanced range uses the same hardware as the 0 to 20 mA range but automatically provides 4 to 20 mA range scaling with the exception that negative digital values are provided to the user for input current levels between 4 mA and 0 mA. This gives you the capability of selecting a low alarm limit that detects when the input current falls from 4 mA to 0 mA, which provides for open-wire fault detection in 4 to 20 mA applications. High and Low alarm limits are available on all ranges. Ranges can be configured on a per channel basis.

User data in the %AI registers is in 16-bit 2's complement format (0 to 20 mA range only). Resolution of the converted signal is 12 bits binary (1 part in 4096) on the 0 to 20 mA range. The placement of the 12 bits from the A/D converter in the %AI data word is shown below.

MSB												LSB			
X	D11	D10	D9	D8	D7	D6	D5	D4	D3	D2	D1	D0	X	X	X

X=not applicable to this discussion.

The relationship between the current input and the data from the A/D converter is show below.

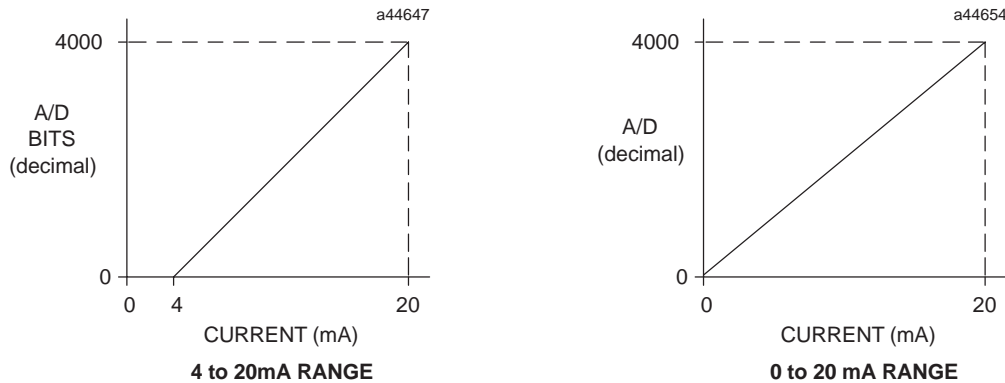

Figure 12-1. A/D Bits vs. Current Input

If the current source is reversed into the input, or is less than the low end of the current range, then the module will output a data word corresponding to the low end of the current range (0000H in %AI). If an input that is out of range is entered (that is, it is greater than 20 mA), the A/D converter will output up to full scale (corresponding to 7FFFH in %AI).

Voltage Operation

In the *0 to +10 V default range*, user data is scaled so that 0 volts corresponds to a count of 0 and +10 volts corresponds to a count of 32000. The -10 to +10 volt range is selected by changing the

configuration parameters using the Logicmaster 90-30/20/Micro configurator software or the Hand-Held Programmer. In the *-10 to +10 volt range* user data is scaled so that -10 volts corresponds to a count of -32000 and +10 volts corresponds to a count of +32000. Full 12-bit resolution is available over either range.

Since converters used in the analog input channels are 12-bit converters, not all of the 16 bits in the data tables contain data required for the conversion. A version of the 12 bits is placed within the 16-bit data word corresponding to the analog point (in the %AI table). The Series 90-30 PLC system handles the integration differently for the various analog modules.

The CPU does not manipulate the data from the input channels before placing it within the word in the %AI data table. The bits in the %AI data table which were not used in the conversion by the input channel are forced to 0 (zero) by the analog input channel. Placement of the 12 data bits from the A/D converter for an analog current input data word for the 16-Channel Analog Voltage Input module in unipolar range is shown below.



Analog values are scaled over the range of the converter. Factory calibration adjusts the analog value per bit (resolution) to a multiple of full scale (that is, 2.5 mV/bit for unipolar; 5 mV/bit for bipolar). This calibration leaves a normal 12-bit converter with 4000 counts (normally $2^{12} = 4096$ counts). The data is then scaled with the 4000 counts over the analog range. For example, the data to the A/D converter for the Analog Voltage Input is scaled as shown below.

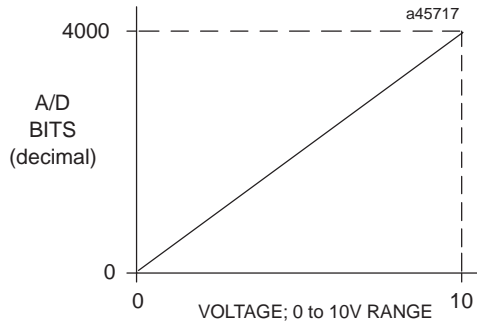

Figure 12-2. A/D Bits vs. Voltage Input

IC693ALG442 Output Modes and Current/Voltage Ranges

Current Operation

In the 4 to 20 mA range user data is scaled so that 4 mA corresponds to a count of 0 and 20 mA corresponds to a count of 32767. In the 0 to 20 mA range, user data is scaled so that 0 mA corresponds to a count of 0 and 20 mA corresponds to 32000. Note that in the 0 to 20 mA mode, you can enter a value up to 32767 which provides a maximum output of approximately 20.5 mA. Scaling of the current output for both the 4 to 20 mA range and the 0 to 20 mA range is shown below. In current mode the module also provides an open loop fault detect which is reported to the PLC in the %I table.

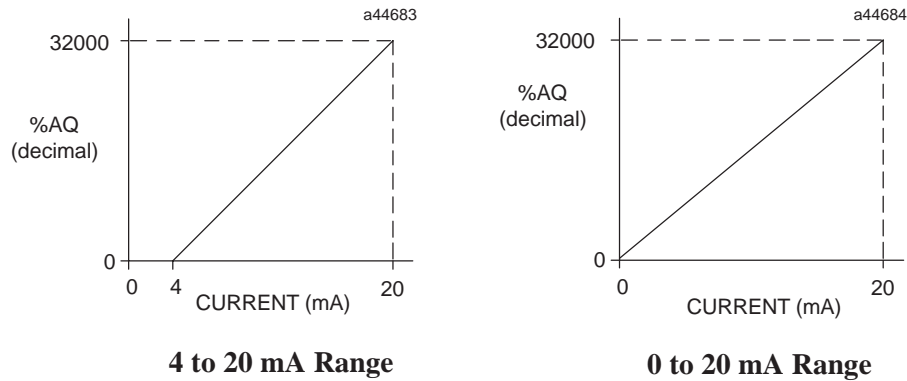

Figure 12-3. Scaling for Current Output

Voltage Operation

For *Voltage Operation* in the default unipolar mode (0 to +10 volts), user data is scaled so that 0 volts corresponds to a count of 0 and +10 volts corresponds to a count of 32000. In this mode, you can enter up to 32767 for an overrange of approximately 10.24 volts output. In the -10 to +10 volt range user data is scaled so that -10 volts corresponds to a count of -32000 and +10 volts corresponds to a count of +32000. In this range, you can enter -32768 to +32767 for an overrange of approximately -10.24 volts to +10.24 volts.

Scaling of the voltage output for both the 0 to +10 volt range and the -10 to +10 volt range is as shown below.

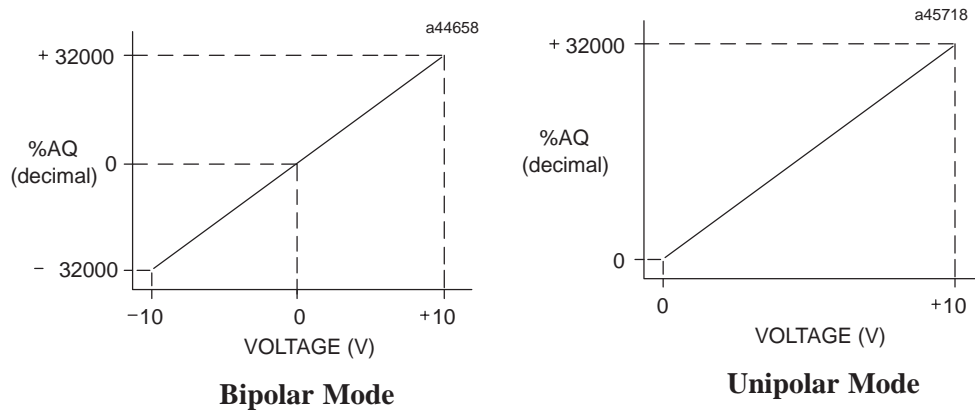

Figure 12-4. Scaling for Voltage Output

CPU Interface to the IC693ALG442 Analog Combo Module

The Series 90-30 PLC uses the data within the %AI and %AQ data table to record analog values for use by the programmable controller. For detailed information on the CPU interface to analog modules, refer to the “Hardware Description of Analog Module” section at the beginning of this chapter.

Status Reporting

The Analog Combo module provides status information to the PLC. This status information is updated once each PLC sweep and consists of the following items:

- *health of the module* (all ranges)
- *overload or open wire detect* (current output mode only)
- *alarm low and high status* (input channels)
- *status of the user-supplied power to the module* (all ranges)

Power Requirements and LEDs

This module requires a maximum of 95 mA from the 5V bus on the PLC backplane for the logic side. The module’s analog power *must be supplied* by a single, user supplied+24 VDC power source. This includes current loop output power and voltage output load power. This user supply requires a maximum current of 129 mA.

There are two green LED indicators on the module which provide module and user supply status. The top LED, **OK**, provides module status information, and the bottom LED, **USOK**, indicates whether the user supply is present and is above a minimum designated level. Note that both LEDs are powered from the +5V backplane power bus.

The LEDs have six possible status combinations, which are described below.

LED Status Indications for IC693MDL442			
Combination	LED	Status	Description
1	OK	ON	Module OK and configured
	USOK	ON	User power is present
2	OK	FLASH	Module OK but not configured
	USOK	OFF	No user power
3	OK	FLASH	Module OK but not configured
	USOK	ON	User power is present
4	OK	ON	Module OK and configured
	USOK	OFF	No user power
5	OK	OFF	Module is defective or no +5V backplane power present
	USOK	OFF	User power may or may not be present
6	OK	OFF	Module not OK
	USOK	ON	User power is present

Location in System

The Analog Combo module is compatible with all Series 90-30 CPU models and may be installed in any I/O slot of any Series 90-30 baseplate.

References Used and Maximum Modules per System Considerations

The number of IC693ALG442 Analog Combo modules that can be installed in a system depends on the amount of %AQ, %AI, and %I references available. Each module uses 2 %AQ references and 4 %AI references (depending on status configuration) and 8, 16 or 24 %I references (depending on alarm status configuration). The number of these references is dependent on the type of CPU in your system.

Please refer to the “Maximum Number of Analog Modules per System” table in Chapter 8 to determine how many Analog Combo modules can be installed for the various CPU models.

IC693ALG442 Analog Module Field Wiring Connections

Connections to this module from user devices are made to screw terminals on a removable 20-terminal connector block mounted on the front of the module. The actual terminals used are described in the following table and are shown in the following wiring diagrams.

Terminal Assignments

Pin assignments for the 20 terminal I/O connector on the Analog Combo module are as shown in the following table.

Table 12-2. Terminal Pin Assignments for IC693ALG442

Pin Number	Signal Name	Signal Definition
1	24VIN	User Supplied +24 Volt Input
2	JMP1	Jumper terminal for connecting 250 Ω sense resistor for CH1
3	JMP2	Jumper terminal for connecting 250 Ω sense resistor for CH2
4	+CH1	Positive connection for differential analog input channel 1
5	+CH2	Positive connection for differential analog input channel 2
6	-CH1	Negative connection for differential analog input channel 1
7	-CH2	Negative connection for differential analog input channel 2
8	JMP3	Jumper terminal for connecting 250 Ω sense resistor for CH3
9	JMP4	Jumper terminal for connecting 250 Ω sense resistor for CH4
10	+CH3	Positive connection for differential analog input channel 3
11	+CH4	Positive connection for differential analog input channel 4
12	-CH3	Negative connection for differential analog input channel 3
13	-CH4	Negative connection for differential analog input channel 4
14	V _{out} CH1	Voltage output for channel 1
15	I _{out} CH1	Current output for channel 1
16	V _{out} CH2	Voltage output for channel 2
17	I _{out} CH2	Current output for channel 2
18	V COM	Common return for voltage outputs
19	I RET	Common return for User supplied +24 V and current outputs
20	GND	Frame ground connections for cable shields

IC693ALG442 Analog Combo Module Field Wiring Diagram

The following figure provide information for connecting field wiring to the user terminal board on the Analog Combo module.

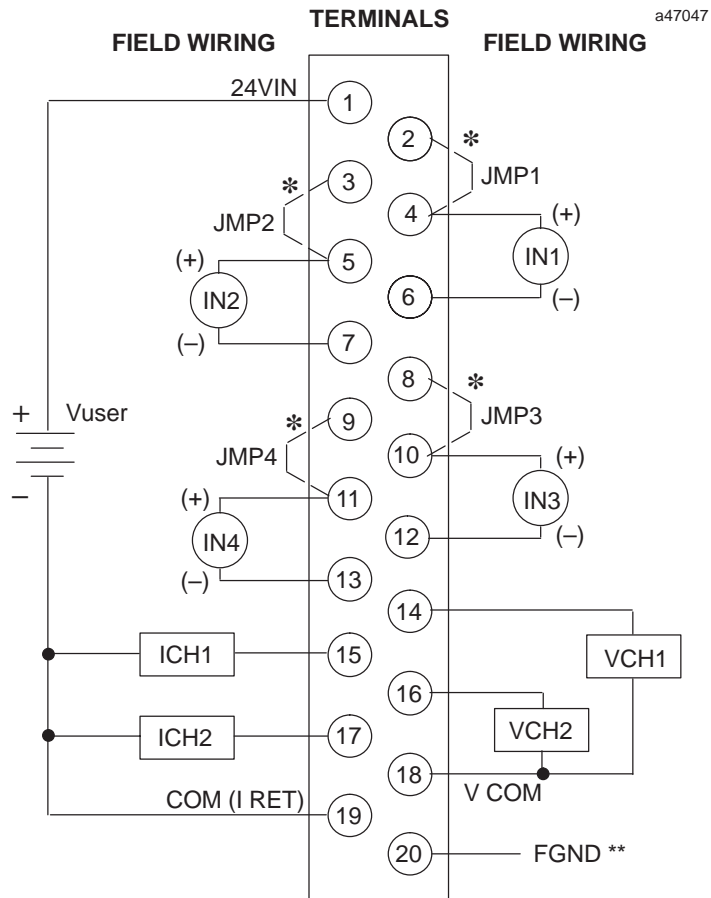

* ADD JMP1 - JMP4 for 250Ω SENSE RESISTOR (CURRENT INPUT MODE ONLY)
 ** OPTIONAL SHIELD CONNECTION

Figure 12-5. Field Wiring for Analog Combo Module - IC693ALG442

Notes

1. Each Input channel can be configured independent of other Input channels to operate as a voltage input *or* a current input – *not both simultaneously*.
2. Each Output channel can be configured independent of other Output channels to operate as a voltage output *or* a current output – *not both simultaneously*.
3. **Please see Chapter 2 for wiring and shield ground connection information.**

IC693ALG442 Analog Combo Module Block Diagram

The following figure is a block diagram of the Analog Combo module.

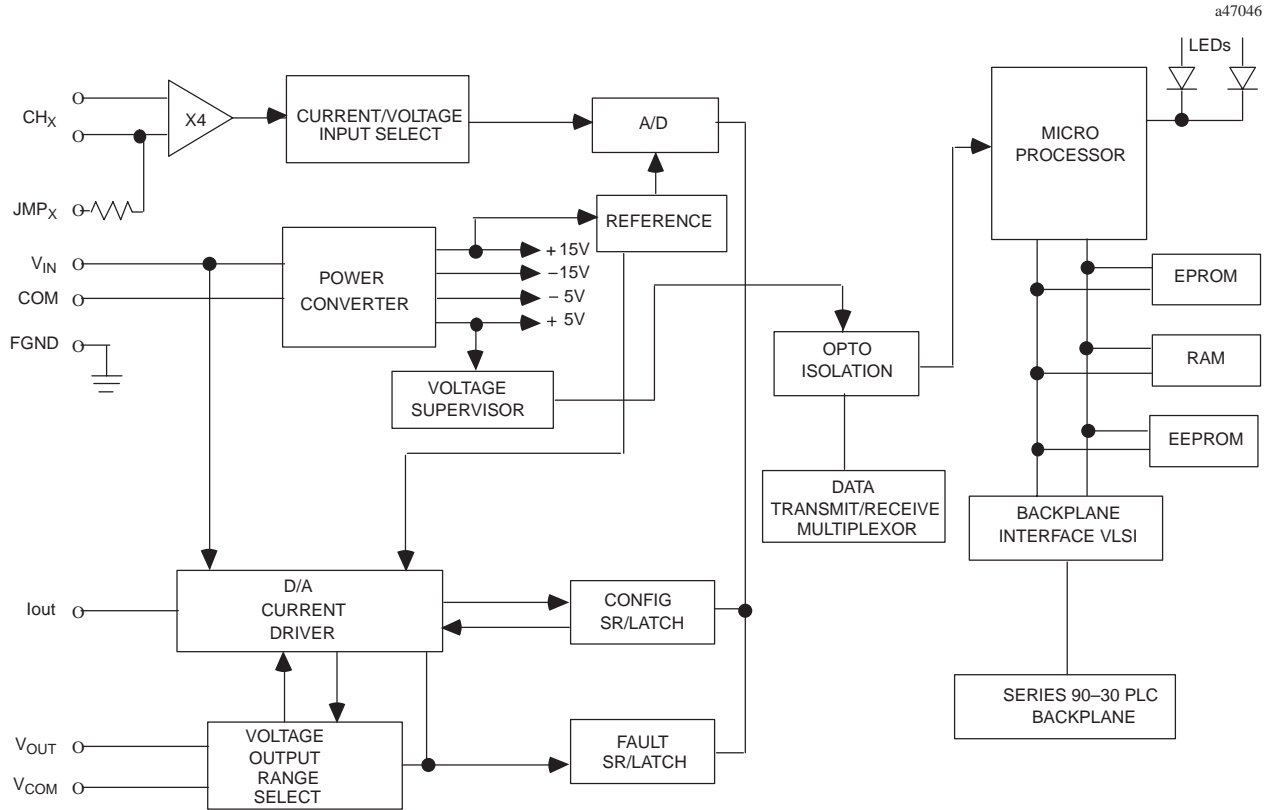

Figure 12-6. Analog Combo Module Block Diagram - IC693ALG442

Configuring the IC693ALG442 Analog Combo Module

The Analog Combo module can be configured using the Logicmaster, VersaPro, or Control programming software configurator function, or with the GE Fanuc Hand-Held Programmer.

The parameters that can be configured are described in the following table. Configuration procedures using Logicmaster 90-30/20/Micro Programming Software and the Hand-Held Programmer are described in the following pages.

Table 12-3. Configuration Parameters for IC693ALG442

Parameter	Description	Values	Defaults	Units
<i>STOP MODE</i>	Output state when module toggled from RUN to STOP mode	HOLD or DEFLOW	HOLD	N/A
<i>%AI ADR</i>	Starting address for the %AI reference type	standard range	%AI0001, or next highest available reference	N/A
<i>%AQ ADR</i>	Starting address for the %AQ reference type.	standard range	%AQ0001, or next highest available reference	N/A
<i>%I ADR</i>	Starting address for the %I reference type	standard range	%I0001, or next highest available reference	N/A
<i>%I SIZE</i>	Number of %I status locations	8, 16, 24	8	bits
<i>RANGE OUTPUT</i>	Type of output range	0,+10 V, -10,+10 V, 4,20 mA, 0, 20mA	0,+10 V	volts (Voltage) mA (Current)
<i>RANGE INPUT</i>	Type of input range	0,+10 V, -10,+10 V, 4,20 mA, 0, 20mA, 4-20 mA Enhanced	0,+10 V	volts (Voltage) mA (Current)
<i>ALARM LO</i>	Low limit alarm value	-32768 to 32759	0	User counts
<i>ALARM HIGH</i>	High limit alarm value	-32767 to 32760	+32000	User counts

For detailed information on configuration of the Analog Combo module, see

- *Configuration Using Logicmaster 90-30/20/Micro Programming Software* beginning on page 3-93.
- *Configuration Using the Hand-Held Programmer* beginning on page 3-104.

Configuring IC693ALG442 Using Logicmaster Software

This section describes how to configure the IC693ALG442 Analog Combination module using the configurator function in Logicmaster 90-30/20/Micro Programming Software. *Configuration can also be done using VersaPro or Control Programming Software. For details refer to the VersaPro or Control online help.*

To configure an Analog Combo module on the I/O Configuration Rack screen, follow these steps:

1. Move the cursor to the desired rack and slot location. The slot may be either unconfigured or previously configured.
2. Press the **1m30 i o** key (**F1**). Your screen will change to one similar to the one shown below.

```

RACK 1d in 2d out 3d mix 4a in 5a out 6a mix 7other 8 9 10
>
SERIES 90-30 MODULE IN RACK 2 SLOT 3
SOFTWARE CONFIGURATION
SLOT 3 Catalog #:
C:\LM90\LESSON PRG: LESSON OFFLINE CONFIG VALID
REPLACE
  
```

3. From this screen, press the **a mix** key (**F6**). Your screen will change to one similar to the one shown below.

```

RACK 1d in 2d out 3d mix 4a in 5a out 6a mix 7other 8 9 10
>
SERIES 90-30 MODULE IN RACK 2 SLOT 3
SOFTWARE CONFIGURATION
SLOT 3 Catalog #:
CATALOG # DESCRIPTION TYPE
1 IC693ALG442 ANALOG CURRENT/VOLTAGE I/O
<< CURSOR TO THE DESIRED CATALOG NUMBER AND PRESS THE ENTER KEY >>
<< PRESS PGDN KEY FOR NEXT PAGE, PGUP KEY FOR PREVIOUS PAGE >>
C:\LM90\LESSON PRG: LESSON OFFLINE CONFIG VALID
REPLACE
  
```

- 4. Currently, there is only one selection. (If more than one selection appears, use your **Cursor Movement** (or **Arrow**) keys to move to Catalog # IC693ALG442.) Press **Enter** to accept this selection and to move to the screen shown below.

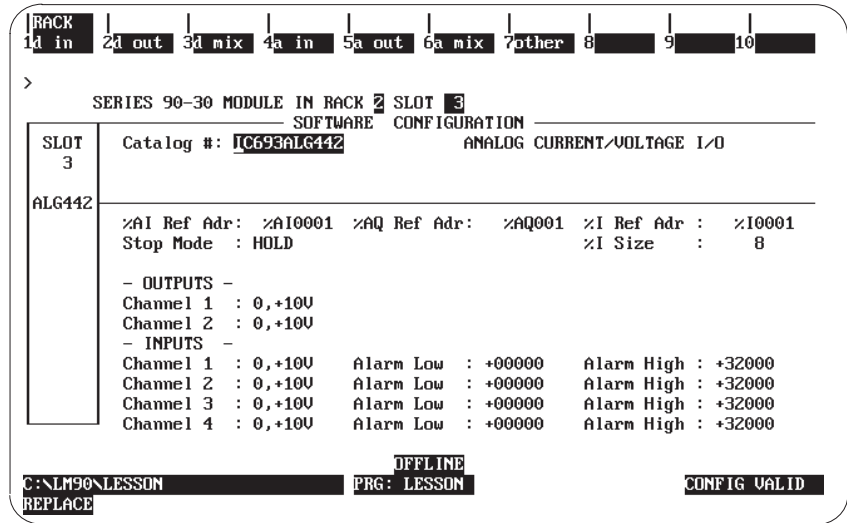

- 5. All the remaining configuration does not have to be done on this screen. You can move your cursor from field to field by pressing the **Cursor Movement** (or **Arrow**) keys. When you are in the field you want to modify, you can either type in your choice or press the **Tab** key to scroll through the available selections (or **Shift-Tab** to reverse the direction of the scrolling).

Note

The entry in the **Stop Mode** field (**HOLD** or **DEFLOW** (Default **LOW**)) determines how the outputs will behave when the module is toggled from **RUN** to **STOP** mode. When this value is set to **HOLD** (default), the outputs will retain their last state. When you change this value to **DEFLOW**, the output will go to zero.

Other Configuration Considerations

The entry in **%I Size** will only accept 8, 16 and 24, and will accept only %I addresses. This field denotes the number of bits returned to the user. The only allowable entries for the **%AI Ref Adr** are %AI addresses. Similarly, the only allowable entries for the **%AQ Ref Adr** are %AQ addresses.

The **Alarm Low** limit for each channel must be less than its corresponding **Alarm High** limit.

The **%AI Ref Adr** field is the reference address for the %AI data and points to the start of the locations in the %AI memory where the input data to the module begins. Each channel provides 16 bits of analog output data as an integer value from 0 to 32,767 or -32768 to 32,767, depending on the range type selected.

The **%AQ Ref Adr** field is the reference address for the %AQ data and points to the start of the locations in the %AQ memory where the output data to the module begins. Each channel provides 16 bits of analog output data as an integer value from 0 to 32,767 or -32768 to 32,767, depending on the range type selected.

For detailed information of the data format, see the *CPU Interface to Analog Modules* section at the beginning of this chapter.

%I Status Information

The **%I Ref Adr** is the reference address for the %I data and points to the start of the locations in the %I memory (that is, the Input Table) where status information from the module is reported. You can select the number of %I status locations reported to the PLC by editing the value in the **%I Size** field. Allowable values in the %I Size field are 8, 16, and 24 which refer to the number of %I locations reported to the PLC. For %I SIZE values 8 or greater, the data brought back is in the format described in the following tables.

First eight %I locations - (available for %I SIZE values 8, 16, 24)

%I Locations	Description
%I	Module OK - 0 indicates NOT OK, 1 indicates module OK.
%I+1	User Supply OK - Indicates when user supply is in specified limits; reads a 0 when User supply below specified limit, 1 when User supply OK.
%I+2 & %I+3	Reserved for future modules. Not used in this module.
%I+4 through 7	☞ See definition for these bits below.

☞ %I+4through 7 (upper 4 bits of first %I byte) hold an error code which is defined as follows:

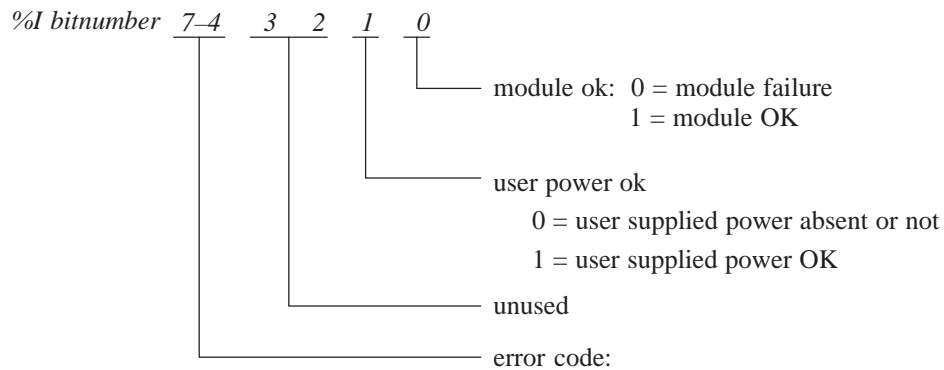

<u>binary</u>	<u>hexadecimal</u>	<u>error</u>
0000	0	no errors
0001	1	invalid channel
0010	2	invalid alarm level
0011	3	invalid ramp time or step
1000	8	invalid E2 COMMREQ function

If the you send E2 COMMREQ data that reflects an invalid condition, the module will ignore the COMMREQ command and return an error code in the upper 4 bits of the first %I byte. The module will NOT stop standard operation if an error is detected; these error bits are for the user's information and can be ignored if desired. The error code will remain until you send an E2 COMMREQ to clear the error code or reconfigure the module.

Only the most recent error will be reported; an existing error code will be overwritten if another error occurs. The priorities for errors are:

1. Invalid COMMREQ function (highest priority)
2. Invalid channel.
3. Invalid data (ramp or alarm parameter) (lowest priority).

Thus, if multiple error conditions exist, the one with the highest priority is reported in the error code.

Second eight locations - (available for %I SIZE values 16, 24)

%I Locations	Description
%I+8	Input: Ch #1 ALARM LO - 0 indicates value above limit; 1 below or =
%I+9	Input Ch #1 ALARM HI - 0 indicates value below limit; 1 above or =
%I+10	Input Ch #2 ALARM LO - 0 indicates value above limit; 1 below or =
%I+11	Input Ch #2 ALARM HI - 0 indicates value below limit; 1 above or =
%I+12	Input Ch #3 ALARM LO - 0 indicates value above limit; 1 below or =
%I+13	Input Ch #3 ALARM HI - 0 indicates value below limit; 1 above or =
%I+14	Input Ch #4 ALARM LO - 0 indicates value above limit; 1 below or =
%I+15	Input Ch #4 ALARM HI - 0 indicates value below limit; 1 above or =

The third eight locations (available for %I SIZE values 24)

%I Locations	Description
%I+16	Output Ch #1 BROKEN WIRE 0 = OK, 1 = Wire Broken (Current modes only)
%I+17	Output Ch #2 BROKEN WIRE 0 = OK, 1 = Wire Broken (Current modes only)
%I+18 through %I+23	Reserved for future modules. Not used in this module

One of four input or output ranges can be selected; two are voltage ranges. The default range is 0 to +10V, where input or output voltage values range from 0 to 10 volts. In input mode they report 0 to 32767 integer values to the CPU and in output mode values between 0 and 32767 are sent to the module. In the -10 to +10V range, values between -32768 to 32767 are sent or received from the CPU over an input voltage range of -10 to +10V.

The two current ranges are 4 to 20 mA, and 0 to 20 mA. In each of the current ranges, values between 0 and 32767 are reported back from the module to sent to the module for the entire range.

Values Sent From CPU to Module for Output Channels

The following tables show values sent from the CPU to the module for the Output channels.

Range	Module Mode	*Allowed Values	Sent values from CPU
0 to 10 V	Voltage	0 to 32767	0 to 32767
-10 to 10 V	Voltage	- 32768 to 32767	-32768 to 32767
4 to 20 mA	Current	0 to 32000*	0 to 32767
0 to 20 mA	Current	0 to 32767	0 to 32767

* *Allowed Values* refers to the values that are valid. If a value outside the specified range is sent, the module clips it to the nearest valid value before sending it to the Digital to Analog Converter. No errors are returned.

The following table shows values sent from the module back to the PLC for the Input channels.

Range	Module Mode	Sent values to CPU
0 to 10 V	Voltage	0 to 32767
-10 to 10 V	Voltage	-32768 to 32767
4 to 20 mA	Current	0 to 32767
0 to 20 mA	Current	0 to 32767
0 to 20 mA Enhanced	Current	-8000 to 32767

The ALARM LO and ALARM HI data fields allow you to enter values that cause *alarm* indications to be passed to the PLC. Each channel has a low limit alarm value (ALARM LO) and a high limit alarm value (ALARM HI). These alarm values cause %I points to be set as indicated in the tables on page 3-95 and 3-96. Values can be entered in all high and low limit fields. Values entered without a sign are assumed to be positive. The allowable values are shown in the following table.

RANGE	Possible limit values
0 to 20 mA	0...32760
4 to 20 mA	0...32760
4 to 20 mA Enhanced	-8000...32760
0 to 10V	0...32760
-10 to +10V	-32768...32760

IC693ALG442 Ramp Mode Operation

The ramp mode operation represents a separate mode of the module's outputs. When an output channel is not in ramp mode, new values entered in the corresponding %AQ reference cause the output to step to the commanded values as shown in Figure 3-52. When an output channel is in ramp mode, new values entered in the corresponding %AQ reference cause the output to ramp to the given values using ramp variables which have been assigned to the channel using ladder logic. The ramp is composed of output steps taken every 1 millisecond.

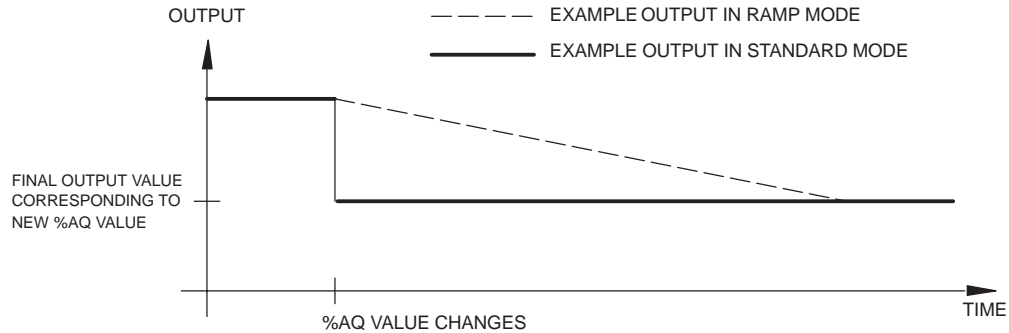

Figure 12-7. Output Behavior in Ramp Mode and in Standard Mode

The default mode of both outputs is *standard mode*. Ramp mode and ramp variables are set using an E2 COMMREQ in ladder logic as described below. The mode of each output channel is set independent of the mode of the other channel. When an output is in ramp mode, two lower-level modes can be used to specify the ramp slope: **time mode**, in which the user provides the total ramp time in milliseconds, and **step mode**, in which the user provides the step in %AQ counts that will be taken every 1 millisecond.

Setting the Ramp Mode

An E2 COMMREQ is used to change the ramp mode of an output channel. This is the same COMMREQ that is used to change the input alarm limits of the module and clear the %I error code. When the module receives the COMMREQ, the first word, or *command* word, is checked to determine whether the ramp settings or alarm limits are being changed or whether the %I error code is being cleared.

When step mode is specified, the second COMMREQ data word contains the ramp step in %AQ counts. Valid step values range from 1 to 32000. The direction of the ramp is determined when the value of the corresponding %AQ reference changes. Once the ramp mode and step have been set, changing the corresponding %AQ value causes the output to ramp to the new value.

When time mode is specified, the second COMMREQ data word contains the total time in milliseconds it will take for the output to ramp from the present output value to the final output value. The present and final values are specified by the old and new values of the corresponding %AQ reference. Valid ramp time values range from 1 to 32000, which correspond to ramp times of 1 millisecond to 32 seconds. Once the ramp mode and time have been set, changing the corresponding %AQ value causes the output to ramp to the new value.

If an E2 COMMREQ is issued to the module to change the ramp settings while the indicated output is in the process of ramping, the new ramp settings will take effect as follows:

- If the ramp mode is turned off during a ramp, the output will step completely to the final value (indicated by the corresponding %AQ reference).
- If step mode is turned on during a ramp, the new step is used as soon as the COMMREQ is processed (assuming that the step is valid).
- If time mode is turned on during a ramp, the module will immediately begin a new ramp using the present output as the starting output and the present time as the start time.

In all cases, changing the value of the corresponding %AQ reference will cause the output to begin a new ramp from the present output value.

Error Handling

If the module receives E2 COMMREQ data that indicates an invalid channel or a step height or ramp time that is out of range, the module will ignore the COMMREQ and return an error code in the first byte of %I data assigned to the module. The error code will be cleared when a Clear Errors E2 COMMREQ is sent to the module or when the module is reconfigured. Range checking of %AQ values received by the module is performed before the values are used in ramp computations. %AQ data which is out of range is clipped to the nearest valid value by the module.

E2 COMMREQ for IC693ALG442

The E2 COMMREQ allows you to modify the input alarm limits, set the output ramp mode and parameters, and clear the %I error code. The E2 COMMREQ uses the standard COMMREQ format. See Chapter 4 of the *Series 90-30/20/Micro PLC CPU Instruction Set Reference Manual*, GFK-0467, and Chapter 8 of the *Hand-Held Programmer for Series 9030/90-20/Micro Programmable Controllers User's Manual*, GFK-0402, for more information on the COMMREQ.

E2 COMMREQ Command Block

The E2 COMMREQ command block consists of 10 words as shown in Table 3-25. Example E2 COMMREQ data in hexadecimal format is included in the table for clarity.

Table 12-4. E2 COMMREQ Command Block Definitions

Address	Data Description	Example Data
Start Address	Always 0004 for this module	0004
+1	Not used	0000
+2	COMMREQ status data type	0008 (%R)
+3	COMMREQ status address (zero-based)	0000 (%R0001)
+4	Not used	0000
+5	Not used	0000
+6	Command type (E2 → message ID for 6 byte data command to ALG442) and command parameter (1 → write)	E201
+7	Byte length of data sent to ALG442	0006
+8	Data type	0008 (%R)
+9	Data address (zero based)	0064 (%R0101)

The decimal and hexadecimal values which specify COMMREQ data types are shown in Table 3-26. The data format and command word description for the E2 COMMREQ are shown in Table 3-27. The first word holds the command word, the second word holds data for changing alarm or ramp parameters and the third word is unused. The %R addresses correspond to the example command block data in Table 3-25.

Table 12-5. COMMREQ Data Types

For This Data Type	Enter This Number	
	Decimal	Hexadecimal
%I Discrete Input	28	1C
%Q Discrete Output	30	1E
%R Register	8	08
%AI Analog Input	10	0A
%AQ Analog Output	12	0C

Table 12-6. E2 COMMREQ Data and Command Word Formats

E2 COMMREQ Data			Channel Convention *
word 1	%R0101	command word	0 = channel 1
word 2	%R0102	alarm or ramp data	1 = channel 2
word 3	%R0103	unused	2 = channel 3
			3 = channel 4

Command Word	Description
000x	Change low alarm of channel x using absolute mode; word 2 holds the new alarm value.
001x	Change high alarm of channel x using absolute mode; word 2 holds the new alarm value.
002x	Change low alarm of channel x using relative mode; word 2 holds the change of the alarm value.
003x	Change high alarm of channel x using relative mode; word 2 holds the change of the alarm value.
004x	Channel x ramp mode off; places channel in standard mode.
005x	Channel x ramp step mode on; word 2 holds the step taken each millisecond.
006x	Channel x ramp time mode on; word 2 holds the total ramp time.
00C0	Clear %I error code; word 2 is ignored.

* 1 through 4 are valid channels for changing alarm levels.

1 and 2 are valid channels for setting ramp modes.

You can change the high and low alarm limits for any of the four input channels. Two modes are available to modify the alarm data: *absolute* mode and *relative* mode.

- When using *absolute mode*, the alarm data sent by the COMMREQ specifies the actual new alarm value.
- When using *relative mode*, the alarm data specifies the positive or negative change in the alarm value that is added to the present value.

The module verifies that the new alarm limit requested is not out of range and does not violate the condition HIGH>LOW. If an invalid request is made to change an alarm value, the corresponding error code will be returned in the upper four bits of the first byte of %I references assigned to the module.

E2 COMMREQ Example

The following ladder logic provides an example of setting up E2 COMMREQ data and issuing the COMMREQ. As with all COMMREQs, it is recommended that the ladder verify the completion of the E2 COMMREQ in progress before initiating another. This ensures that the module does not receive COMMREQs faster than it can process them. One way to do this is to zero the contents of the COMMREQ status (%R0001 in this example) as the COMMREQ is enabled. Since the status returned for a completed COMMREQ is never zero, a non-zero status word will then indicate that the COMMREQ has completed.

In this example, the COMMREQ command block begins at %R0002 and is initialized on the first scan. It is assumed that the 6 bytes of COMMREQ data sent to the module are moved into %R0101-%R0103 before the COMMREQ is enabled. The module is located in rack 0, slot 2 so the SYSID input to the COMMREQ is 0002. Setting %T0001 moves zero into the COMMREQ status word, enables %T0003 for one sweep to initiate the COMMREQ, and sets %T0002 to begin checking the status word. When a non-zero status word is detected, %T0002 is reset to discontinue checking and %T0004 is set to indicate that the module is ready for the next COMMREQ. Reference %M0001 is set if a COMMREQ fault occurs.

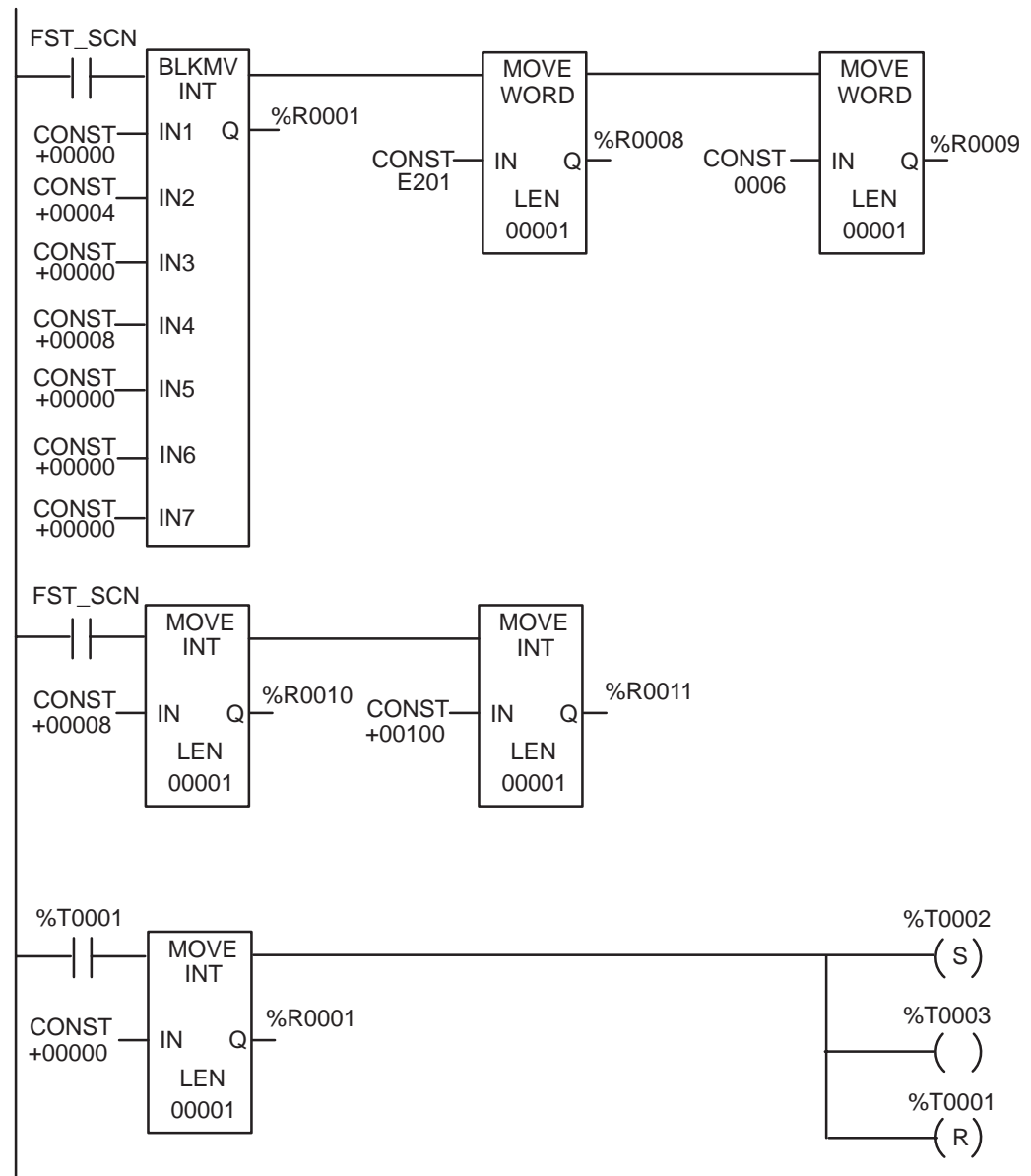

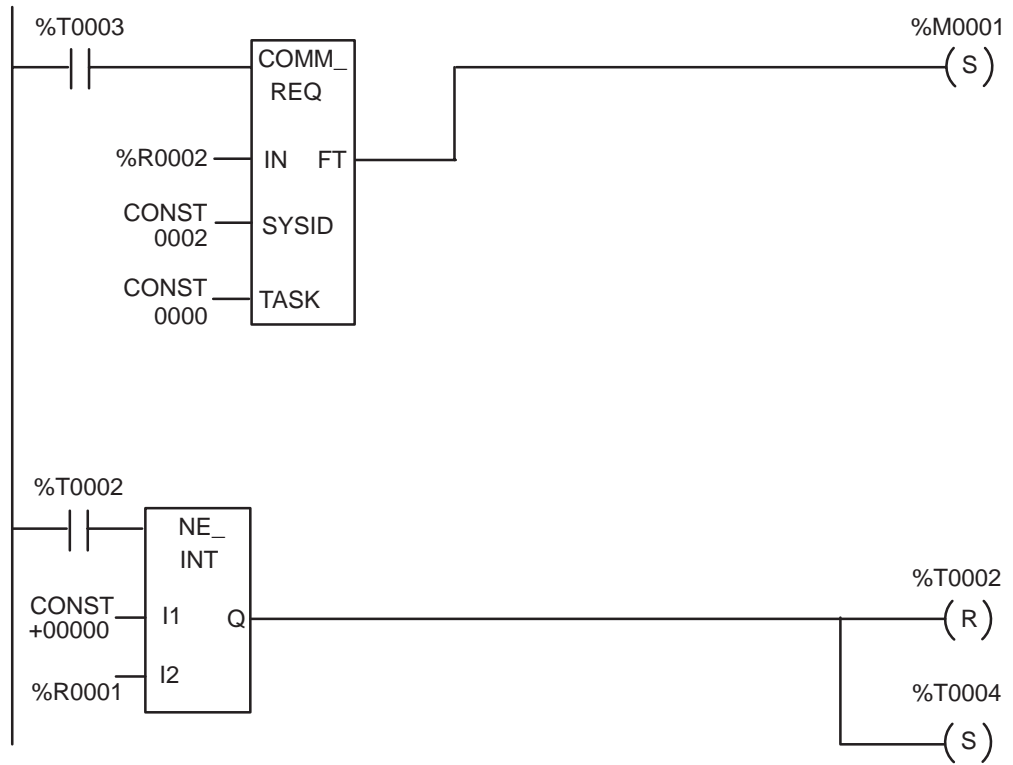

Configuring IC693ALG442 with Hand-Held Programmer

You can also configure the Analog Current/Voltage 4-Channel Input/2-Channel Output module using the Series 90-30 Hand-Held Programmer. In addition to the information in this section, refer to Chapter 6 of the *Hand-Held Programmer for Series 90-30/20/Micro Programmable Controllers User's Manual*, GFK-0402F, or later version, for more information on configuration of Intelligent I/O modules.

Module Present

If a module is physically present in a system, it can be added to the system's configuration by reading the module into the configuration file. For example, assume that an 4-Channel Input/2-Channel Output Analog Current/Voltage module is installed in slot 3 of a Model 311 PLC system. It can be added to the configuration with the following sequence. Use the ↑ and ↓ arrow cursor keys or the # key to display the selected slot.

Initial Display

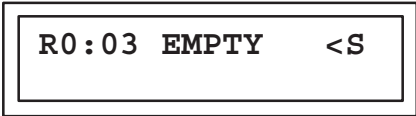

To add the IC693ALG442 module to the configuration, press the **READ/VERIFY, ENT** key sequence. The following screen will be displayed:



Selecting %I Reference

At this point the starting %I reference address for the status data returned from the module must be entered. Notice that the length of the status field (**24**) is displayed as the first two digits following the first **I** on the second line of the display.

Note

This field cannot be changed with the Hand-Held Programmer. However, it can be changed using the Logicmaster 90-30/20/Micro software configurator function. The Hand-Held Programmer will always reflect the currently active length of the status field.

Pressing the **ENT** key will allow the PLC to select the starting address of the status data. You can select a specific starting address by pressing the key sequence for the desired address and pressing the **ENT** key. For example, to specify the starting address as I17, press the key sequence **1, 7, ENT**.

Note

The configured reference addresses will not be displayed until all three reference types (%I, %AI and %AQ) have been assigned starting addresses. Once this is done, the configured addresses can be viewed by scrolling backward using the \square key.

You can press the **CLR** key at any time to abort the configuration you have just selected and return the slot to EMPTY.

After selecting the starting %I address and pressing the **ENT** key, the following screen is displayed.

```
R0:03 AIO 2.00<S
AI04:AI _
```

Selecting %AI Reference

This screen allows you to select the starting address for the %AI reference by specifying the starting reference in the %AI field. Note that the number of references (**04**) is displayed as the first two digits following the first **AI** on the second line of the display.

You can select the next available address or enter a specific address. Pressing the **ENT** key will allow the PLC to select the starting address. You can select a specific starting address by pressing the key sequence for the desired address and pressing the **ENT** key. For example, to specify the starting address as %AI35 press the key sequence **3, 5, ENT**.

Note

The configured reference addresses will not be shown until all three reference types (%I, %AI and %AQ) have been assigned starting addresses. Once this is done, the configured addresses can be viewed by scrolling backward using the \square key.

You can press the **CLR** key while entering the starting address to clear the address field and enter a different address.

After selecting the starting %AI address and pressing the **ENT** key, the following screen is displayed:

```
R0:03 AIO 2.00<S
AQ02:AQ _
```

Selecting %AQ Reference

This screen allows you to select the starting address for the %AQ reference by specifying the starting reference in the %AQ field. Note that the number of references (**02**) is displayed as the first two digits following the first **AQ** on the second line of the display.

You can select the next available address or enter a specific address. Pressing the **ENT** key will allow the PLC to select the starting address. You can select a specific starting address by pressing the key sequence for the desired address and pressing the **ENT** key. For example, to specify the starting address as %AQ35 press the key sequence **3, 5, ENT**. The following screen will be displayed:

```
R0:03 AIO 2.00<S
AQ02:AQ035-0036
```

Once the %AQ starting address has been assigned, the **□** key can be used to view the configured %I and %AI reference addresses. For example, if %I17 and %AI35 are used as starting addresses then the following screen will be displayed after pressing the key sequence **□, □**:

```
R0:03 AIO 2.00<S
I24:I0017-0040
```

Scrolling forward from this screen using the **□** key causes the following screen to be displayed:

```
R0:03 AIO 2.00<S
AI04:AI0035-0038
```

Removing Module From Configuration

The module can be removed from the current rack configuration at any time during the configuration process by pressing the **DEL, ENT** key sequence. The following screen will be displayed:

```
R0:03 EMPTY <S
```

If the **CLR** key is pressed after the **DEL** key (instead of the **ENT** key), the delete operation will be aborted.

Selecting Module Stop Mode

The STOP mode of the module, either HOLD or DEFAULT LOW (DEFLOW), can be displayed and modified using the following procedure. From the %AQ reference screen, press the \square key to scroll to the next screen:

```
R0:03 AIO 2.00 <S
HLS/DEF:HOLD
```

The default STOP mode is HOLD, which indicates that each output will hold its last state when the PLC is placed in STOP mode. You can toggle between the HOLD and DEFLOW modes by pressing the \pm key. Pressing this key once causes the following screen to be displayed:

```
R0:03 AIO 2.00 <S
HLS/DEF:DEF LOW
```

In DEFLOW mode, each output will become zero when the PLC is placed in STOP mode. When the desired mode is displayed, it is accepted by pressing the **ENT** key. To return to the previous screen, press the \square key.

Selecting Output Channel Ranges

The range for each of the output and input channels can be displayed and selected or changed as described below. There are two current and two voltage ranges that can be selected for each output channel. From the STOP mode screen, pressing \square causes the following screen to be displayed:

```
R0:03 AIO 2.00<S
CH 1-AQ:0,10 V
```

You can toggle through the ranges for each channel by pressing the \pm key. Each range will be displayed as shown below.

```
R0:03 AIO 2.00<S
CH 1-AQ:-10,+10
```

```
R0:03 AIO 2.00<S
CH 1-AQ:4,20 MA
```

```
R0:03 AIO 2.00<S  
CH 1-AQ:0,20 MA
```

When the desired range is displayed, it is accepted by pressing the **ENT** key. To return to the previous screen, press the **←** key. To view the range display for the next channel, press the **→** key. If the **→** key is pressed, the following screen will be displayed:

```
R0:03 AIO 2.00<S  
CH 2-AQ:0,10 V
```

Edit the range for this channel as you did for the first channel. To view the range display for the first *input* channel, press the **←** key.

Selecting Input Channel Ranges

There are three current and two voltage ranges that can be selected for each input channel. The following screen is displayed for the first input channel:

```
R0:03 AIO 2.00<S  
CH 1-AI:0,10 V
```

You can toggle through the ranges for each input channel by pressing the **±** key. Each range will be displayed as shown below.

```
R0:03 AIO 2.00<S  
CH 1-AI:-10,+10
```

```
R0:03 AIO 2.00<S  
CH 1-AI:4,20 MA
```

```
R0:03 AIO 2.00<S  
CH 1-AI:0,20 MA
```

```
R0:03 AIO 2.00<S  
CH 1-AI:4-20 MA+
```

When the desired range for the module is displayed, it is accepted by pressing the **ENT** key. To return to the previous screen press the **←** key.

Selecting Low and High Alarm limits

The low and high alarm limit screens for each channel are displayed immediately following the channel range screen. The following screen is displayed if the \square key is pressed from the range screen for input channel 1:

```
R0:03 AIO 2.00<S
CH 1 LO: 0
```

This display contains the entry field for the *low alarm limit* for this channel. You can enter positive or negative values using the numeric keys (0 through 9) and the \pm key. Press the **ENT** key to accept the value you have entered. When an alarm value that is not in the allowed range (-32768 to 32760) is entered, a DATA ERR message will be displayed as shown in the following example:

```
R0:03 DATA ERR<S
CH 1 LO:-33000_
```

The bad data must be corrected before the HHP will allow you to move to another screen. When a valid low alarm has been entered, press the \square key to move to the high alarm limit screen for this channel. The following screen will be displayed:

```
R0:03 AIO 2.00<S
CH 1 HI: 32000
```

This screen contains the entry field for the *high alarm limit* for this channel. You can enter positive or negative values using the numeric keys (0 through 9) and the \pm key. To view the range screen for the next input channel, press the \square key. The following screen will be displayed:

```
R0:03 AIO 2.00<S
CH 2-AI:0,10 V
```

Edit the ranges and alarm limits for this channel and subsequent channels as you did for the first channel.

Freeze Mode

If an alarm value in the allowed range (-32768 to 32760) is entered that results in an invalid condition, such as a low alarm limit greater than an upper alarm limit or a negative alarm for a channel in a unipolar range, the module will enter *freeze* mode. In this mode, you will not be allowed to move beyond the present channel parameters (range, low alarm limit and high alarm limit) until the invalid condition is corrected or removed. Freeze mode is indicated on the HHP screen by an asterisk (*) after the slot number. For example, if a low alarm limit of -1000 is entered for input channel 1 in the 0,10V range the following screen will be displayed:

```
R0:03*AIO 2.00<S
CH 1 LO: -1000
```

If you press either the key or the key to change slots, the following message will be displayed:

```
SAVE CHANGES? <S
<ENT>=Y <CLR>=N
```

If you *do not* want to save the changes to the CPU, press the **CLR** key. The following message will be displayed:

```
DISCARD CHGS? <S
<ENT>=Y <CLR>=N
```

If you *do not* want to discard the changes you have made, press the **CLR** key. This will return you to the last parameter that was being modified with all changes intact.

If you *do* want to discard the changes you have made, press the **ENT** key. The Hand-Held Programmer will then return you to the last parameter that was being modified with the data reset to its previous value.

If you want to save the data to the CPU from the SAVE CHANGES? screen shown above, press the **ENT** key. If the module is in freeze mode, the Hand-Held Programmer will return with a CFG ERR message on the screen as follows:

```
R0:03*CFG ERR <S
CH 1 LO: -1000
```

If all data is valid, the HHP display will move to an adjacent slot when either the key or key is pressed.

Saved Configurations

Configurations that contain Analog Combo modules can be saved to an EEPROM or MEM card and read from that device into the CPU at a later time. MEM cards and EEPROMs containing these configurations can be read into any Release 4 or later Series 90-30 CPU (cannot be read into a Series 90-20 CPU). Refer to Chapter 2 of the *Hand-Held Programmer for Series 90-30/20/Micro Programmable Controllers User's Manual* for detailed information on the Save and Restore operations.

Troubleshooting Features of Series 90-30 Hardware

Indicator Lights (LEDs) and Terminal Board

The following figure shows how the indicator LEDs correspond to the circuit connection points on an I/O Module's terminal board. The terminal board terminals are numbered from the top, with the top terminal in the left row being number 1 and the top terminal in the right row being number 2. The numbers alternate between rows with even numbers on the right and odd numbers on the left, as shown in the circuit diagram on the back of the hinged cover.

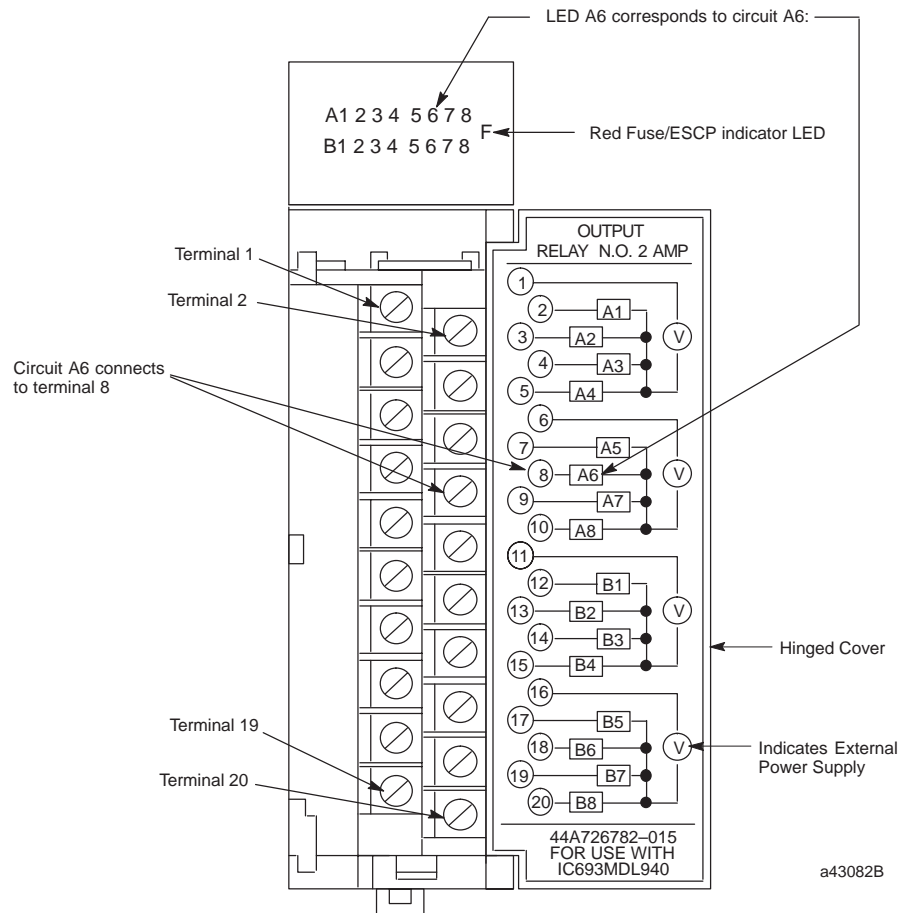

Figure 13-1. Relationship of Indicator Lights to Terminal Board Connections

Module LED Indicators

Input Module LED Indicators

When a discrete input device closes, the corresponding input LED should light to indicate that the signal reached the module. If the light does not turn ON, a voltage check can be made on the module's terminal board or block:

- If the correct voltage is present at the terminal, the corresponding input bit can be checked in the PLC with your programming software. If the software shows that the input bit is at logic 1, the module's LED circuit is defective.
- If the correct voltage level is not present at the terminal, a check can be made at the input field device to determine if the device or interconnecting wiring is defective.

If none of an input module's inputs are working, it may be that the external (field) input power supply is defective, is not powered up, or is not connected properly. (As indicated in the connections diagram in the previous figure, input and output devices are powered from an external power supply, not from inside the module). Input modules are not fused, so the Fuse Indicator LED in the previous picture does not apply to them.

Output Module LED Indicators

When a discrete output address (%Q) is turned on in the ladder program, the corresponding output LED should light to indicate that the signal reached the module.

- If the LED does not turn ON, the module may be defective or the LED light may be bad. Also, make sure that the module is configured correctly (is the correct type, and its assigned memory addresses are correct).
- If the LED turns on but the output device (relay, solenoid, etc.) doesn't operate, a voltage check can be made on the module's terminal board or terminal block, if using one. If the LED turns on but the module doesn't switch the output voltage:
 1. A fuse could be open, if it is a fused module. Check the red "F" LED at the top of the module. If it is on, a fuse is open. If a fuse is open, you probably have a shorted field device or wiring. Note: Output LEDs can be on even if a fuse is open.
 2. The Electronic Short Circuit Protection (ESCP) circuit may be tripped, if the module has this feature. If the red "F" LED at the top of the module is on, the ESDC circuit is tripped. If tripped, you probably have a shorted field device or wiring. Note: Output LEDs can be on even if the ESDC is tripped. Turn off system power and find and correct the short. The ESCP circuit resets when the PLC is power-cycled.
 3. The external field device power supply supplying the output voltage may be defective, turned off, disconnected, have an open fuse, tripped circuit breaker, etc. Note: Output LEDs can be on even if the field power supply is not working.
- If the LED turns on and the module correctly switches the output voltage, check the output device or wiring for an open circuit.
- If the LED turns on, no Fuse is open or no ESCP is tripped, and the external power supply is working correctly, but the module still doesn't switch the output circuit, the module or the module's terminal board is probably defective. Or, for 32-point modules, the

connection cable or terminal block may be defective. If replacing the module at this point in the troubleshooting process still doesn't correct the problem, the baseplate may be defective; however, a defective baseplate is probably the least likely source of the problem.

If none of an output module's outputs are working, it may be that the external (field) output power supply is defective, is not powered up, or is not connected properly. (As indicated in the connection diagram in the previous figure, input and output devices are powered from an external power supply, not from inside the module).

Details on individual discrete output modules can be found in Chapter 7.

Power Supply LED Indicators

The power supplies have four LED indicators. Their functions are explained in detail in the "Power Supplies" chapter.

CPU LED Indicators

There are several different LED arrangements on the various CPUs. These are explained in the "CPUs" chapter of the *Series 90-30 PLC Installation and Hardware Manual*, GFK-0356.

Option Module LED Indicators

There are numerous LED arrangements on the various option modules. The "Option Modules" chapter of the *Series 90-30 PLC Installation and Hardware Manual*, GFK-0356, has some information on this subject. It also directs you, for each module, to further information in the "Documentation" heading for each module.

Troubleshooting Features of Programming Software

Detailed information about the following items are found in GFK-0467, *Series 90-30/20/Micro PLC CPU Instruction Set Reference Manual*, and GFK-0466, *Series 90-30/20/Micro Programming Software User's Manual*.

Ladder Screens

Contacts, connections, and coils displayed on the ladder logic screens that are ON (passing power or energized) are displayed in enhance brightness, allowing the tracing of signals through the ladder logic program. Addresses that refer to physical input (%I and %AI) and output signals (%Q and %AQ) can be checked against module status lights, voltages, etc. to verify that the hardware is working properly.

Configuration Screens

Normally, the following information is obtained from the system documentation. However, if the system documentation is not available, the configuration screens can be used to determine:

- If the software configuration matches the actual hardware assembly. Sometimes, while troubleshooting, a module is installed in an incorrect slot by mistake. (This will create a fault in one of the two system fault tables.) The module that is in the wrong slot will not work, giving the appearance that it is defective. The correct configuration (module locations) can be determined from the Configuration Screens.
- The memory addresses that a particular module is using are listed on that module's configuration screen.

System Fault Tables

There are two system fault tables, the “PLC Fault Table,” and the “I/O Fault Table.” The fault tables can be viewed using the PLC programming software. These fault tables will not report such things as a defective limit switch, but will identify system faults such as:

- Loss of or Missing Modules, System Configuration Mismatch.
- CPU hardware failure, Low Battery
- PLC Software Failure, Program Checksum Failure, No User Program, PLC Store Failures.

System Status References

These discrete references (%S, %SA, %SB, and %SC) can be viewed in the System Reference (Status) Table, or on-screen if used in the ladder program, for determining the status of various conditions and faults. For example, the %SC0009 bit turns on if a fault is logged in either fault table. Another example is that bit %SA0011 will turn on if the CPU memory backup battery is low. The *Series 90-30 PLC CPU Instruction Set Reference Manual*, GFK-0467, includes a “System Status Reference Table.”

Reference Tables

There are two types of reference tables, standard and mixed. These tables show groups of memory addresses and their status. The status of discrete addresses will be shown as either logic 1 or logic 0. For analog and register addresses, values will be displayed. Standard reference tables display only one type of memory address, such as all of the %I bits. Mixed reference tables are created by the user, who selects what addresses to display in the tables. These mixed tables can contain discrete, analog, and register references all in one table. This makes them useful for gathering numerous related addresses on one screen where they can all be viewed or monitored at the same time. This saves time compared with searching or scrolling through the ladder logic screens to find these addresses.

Override feature

This feature must be used with caution to ensure the safety of personnel and equipment. Normally, the machine should not be cycling, and all conditions should be such that the output device can be turned on without any harm being done. This method can be used to check an output circuit from the ladder screen all the way to the device being controlled. For example, when overriding and toggling a %Q output to an ON state, the relay, solenoid, or other device being controlled should turn on or pick up. If it does not, the status light on the output module could be checked, then voltage checks could be made at the module terminal board, the system terminal strip, the machinery terminal strip, the solenoid or relay connections, etc. until the source of the fault is found.

Sequential Event Recorder (SER), DOIO functional instruction

These can be set up to capture the status of specified discrete addresses upon receiving a trigger signal. They may be used to monitor and capture data about certain portions of the program, even when unattended. They can be useful for locating the cause of an intermittent problem. For example, a contact in a string of contacts that maintain power to a coil may, from time to time, momentarily open and interrupt normal operation. However, when maintenance personnel attempt to locate the problem, all of these contacts may test OK. By using the SER or DOIO instruction, the status of all of these contacts can be captured within milliseconds of the time the fault occurs, and the contact that opened will show a status of logic 0 at the moment of capture.

Replacing Modules

Modules do not contain configuration switches. The slot in each baseplate (rack) is configured (using the configuration software) to hold a particular module type (catalog number). This configuration information is stored in CPU memory. Therefore, when replacing a module, you do not have to make any hardware settings on the module itself. You do, however, have to ensure that you install the correct module type in a particular slot.

Be aware that some “intelligent” modules, such as the CPU, PCM, APM, or DSM302, may contain application programs that will need to be reloaded after the module is replaced. For such modules, make sure that up-to-date copies of the application programs are maintained in case they have to be restored later.

For I/O modules with terminal boards, you do not have to rewire a new terminal board in order to replace the module. If the old terminal board is not defective, it can be removed from the old module and reinstalled on the new module without removing any of the wiring. Procedures for removing and installing modules and terminal boards are found in Chapter 2.

Series 90-30 Product Repair

The Series 90-30 products are, for the most part, not considered to be field-repairable. The one exception is that some modules have replaceable fuses. The next section, “Module Fuse List,” identifies these modules and their applicable fuses.

GE Fanuc offers a repair/product warranty service through your local distributor. Contact your distributor for details.

Module Fuse List

Warning

Replace a fuse only with the correct size and type. Do not jumper out a fuse. Using an incorrect fuse or jumpering out a fuse can result in harm to personnel, damage to equipment, or both.

Table 13-1. Fuse List for Series 90-30 Modules

Catalog Number	Module Type	Current Rating	Quantity on Module	GE Fanuc Fuse Part Number	Third Party Source and Part Number
IC693CPU364	CPU Module with embedded Ethernet interface	1A	1	44A725214-001	Littlefuse - R454 001
IC693DVM300	Digital Valve Driver	1A 2A	1 4	N/A N/A	Bussman – GDB-1A Littlefuse – 239002
IC693MDL310	120 VAC, 0.5A	3A	2	44A724627-111 ⁽¹⁾	Bussman – GMC-3 Littlefuse - 239003
IC693MDL330	120/240 VAC, 1A	5A	2	44A724627-114 ⁽¹⁾	Bussman – GDC-5 Bussman – S506-5
IC693MDL340	120 VAC, 0.5A	3A	2	44A724627-111 ⁽¹⁾	Bussman – GMC-3 Littlefuse – 239003
IC693MDL390	120/240 VAC, 2A	3A	5	44A724627-111 ⁽¹⁾	Bussman – GMC-3 Littlefuse – 239003
IC693MDL730	12/24 VDC Positive Logic, 2A	5A	2	259A9578P16 ⁽¹⁾	Bussman – AGC-5 Littlefuse – 312005
IC693MDL731	12/24 VDC Negative Logic, 2A	5A	2	259A9578P16 ⁽¹⁾	Bussman – AGC-5 Littlefuse – 312005
IC693PWR321 and IC693PWR330	120/240 VAC or 125 VDC Input, 30 Watt Power Supply	2A	1 or 2 ⁽³⁾	44A724627-109 ⁽²⁾	Bussman – 215-002 (GDC-2 or GMC-2) Littlefuse – 239-002
IC693PWR322	24/48 VDC Input, 30 Watt Power Supply	5A	1	44A724627-114 ⁽²⁾	Bussman – MDL-5 Littlefuse – 313005
IC693PWR328	48 VDC Input, 30 Watt Power Supply	5A	1	44A724627-114 ⁽²⁾	Bussman – MDL-5 Littlefuse – 313005
IC693PWR331	24 VDC Input, 30 Watt Power Supply	5A	1	44A724627-114 ⁽²⁾	Bussman – MDL-5 Littlefuse – 313005
IC693PWR332	12 VDC Input, 30 Watt Power Supply	5A	1	44A724627-114 ⁽²⁾	Bussman – MDL-5 Littlefuse – 313005
IC693TCM302/303	Temperature Control Module	2A	1	N/A	Littlefuse - 273002

⁽¹⁾ Mounted in clip. Accessible by removing circuit board from module housing.

⁽²⁾ Line fuse. Mounted in clip. Accessible by removing module front cover.

⁽³⁾ IC693PWR321W (and later versions) and IC693PWR330E (and later versions) have two fuses. Earlier versions have one fuse.

Spare/Replacement Parts

Two kits (IC693ACC319 and IC693ACC320) provide mechanical spare parts for Series 90-30 modules. One covers I/O CPU, PCM, and other modules; the other is for power supply modules. These kits provide parts such as module levers, front covers, cases, etc. The following table describes the contents of each kit.

Table 13-2. Spare/Replacement Parts

Spare Parts	Contents
IC693ACC319: Spare parts kit for I/O, CPU, and PCM modules	(qty. 10) I/O, CPU, PCM case lever (qty. 10) Spring pins cap (qty. 2) PCM module front cover (qty. 2) PCM lens cap (qty. 2) CPU module case
IC693ACC320: Spare parts kit for power supplies	(qty. 2) Power supply lever (qty. 2) Spring pin for power supply lever (qty. 2) Spring for power supply lever (qty. 2) Power supply lens cap (qty. 2) Power supply terminal cover
IC693ACC301 (see Note) Memory Backup Battery	(qty. 2) Memory backup battery for CPU and PCM modules
Fuses	See “Fuse List For Series 90-30 Modules” table in this chapter.
Modules	You may wish to maintain spare PLC modules. Many systems have more than one of a particular catalog number, such as power supplies (each rack has one) and I/O modules. In these cases, one of each type would serve as backups for several modules.
IC693ACC311 Removable Module Terminal Board	(qty. 6) Removable terminal boards used on many I/O modules and some Option modules.
44A736756-G01 CPU (CPU350 - 364) Key Kit	Kit contains 3 sets (6 keys). Same key fits all applicable CPUs.

Note: The IC693ACC301 batteries have a shelf life of 5 years (see Chapter 6 of GFK-0356P, or later version, for instructions on how to read battery date codes). Periodically, outdated batteries should be removed from stock and disposed of according to the battery manufacturer’s recommendations.

Preventive Maintenance Suggestions

Table 13-3. Preventive Maintenance Table

Series 90-30 PLC Preventive Maintenance		
Item No.	Description	Recommendation
1	Safety ground and electrical system	Check frequently to ensure that safety ground connections are secure and that electrical cables and conduits are secure and in good condition.
2	CPU Memory backup battery	Replace annually or as appropriate for your application.* Check Chapter 6 of GFK-0356P, or later, for instructions on how to avoid loss of memory contents when replacing battery.
3	Option Module backup battery	Replace annually. Check the option module user’s manual for additional instructions. Check Chapter 6 of GFK-0356P, or later, for instructions on how to avoid loss of memory contents when replacing battery.
4	Ventilation	If using ventilation fan in enclosure, check for proper operation. Keep fingers and tools away from moving fans. Clean or replace ventilation air filter, if using one, at least monthly.
5	Mechanical tightness	With power OFF , check that connectors and modules are seated securely in their sockets and that wire connections are secure. For low vibration installations, perform annually. For high vibration installations, check at least quarterly.
6	Enclosure	Check annually. With power OFF , remove manuals, prints, or other loose material that could cause shorts or ventilation blockage, or that are flammable, from inside of enclosure. Gently vacuum dust and dirt that has collected on components. Use vacuum cleaner, not compressed air, for this task.
7	Program backup	Do this initially after creating any application programs, such as the ladder logic program, motion programs, etc. Then, any time a change is made to a program, make at least one (several is better) new backup copy. Keep old copies (clearly marked) for a reasonable period of time in case you need to go back to the old design. Document each backup copy as to what equipment it is for, date it was created or modified, version number (if any), and author’s name. Keep master backup copies in a safe place. Make working copies available to those responsible for maintaining the equipment.

*See “Factors Affecting Battery Life” in Chapter 6 of GFK-0356P (or later version).

Getting Additional Help and Information

There are several ways to get additional help and information:

GE Fanuc Web Site

There is a large amount of information on the Technical Support section of the GE Fanuc Web site. Sections such as Technical Documentation, Application Notes, Revision Histories, Frequently Asked Questions, and Field Service Bulletins may have the exact information you need. You can access this site at:

<http://www.gefanuc.com/support/>

Fax Link System

This system lets you choose technical help documents to be sent to you on your Fax machine. To use this system follow these steps:

- Call Fax Link at (804) 978-5824 on a touch tone type phone (rotary dial phones will not work for this application).
- Follow the instructions to have a master list (called "Document 1") of Fax Link documents Faxed to you. A master Fax Link list is also available on the GE Fanuc Web site in the Technical Support section (see the "GE Fanuc Web Site" section above).
- Select desired document(s) from the master list, then call Fax Link and specify the document number(s) you want to be Faxed to you. Up to three documents can be ordered per call.

GE Fanuc Telephone Numbers

If you need to speak with a GE Fanuc technical help person, use the applicable telephone number from the following list.

Table 13-4. Technical Support Telephone Numbers

Location	Telephone Number
North America, Canada, Mexico (Technical Support Hotline)	Toll Free: 800 GE Fanuc Direct Dial: 804 978-6036
Latin America (for Mexico, see above)	Direct Dial: 804 978-6036
France, Germany, Luxembourg, Switzerland, and United Kingdom	Toll Free: 00800 433 268 23
Italy	Toll Free: 16 77 80 596
Other European Countries	+352 727 979 309
Asia / Pacific - Singapore	65 566 4918
India	91 80 552 0107

This appendix explains some general terms relating to measurements at analog I/O terminals.

- Bipolar** Bipolar signals can reverse polarity in operation. Reversed signal connections to a bipolar input will produce data of opposite sign.
- Common Mode** This is the voltage between the analog signal wires and the common point of the power supply of a differential signal, or to ground in the case of an isolated signal. It is desirable that all common mode signals are ignored by the circuit, but in practice there is some error introduced in the data. This is specified as Common Mode Rejection Ratio (CMRR), usually expressed in decibels (db). Differential circuits also have a maximum common mode voltage specification, usually stated as a maximum voltage with respect to circuit common. Exceeding the common mode voltage rating of differential signals causes large errors in the data conversion and may affect several points.
- Current Loop** This is a standard analog interface defined by the Instrument Society of America (ISA) in ANSI/ISA-S50-1. The signal level is 4mA to 20mA. Three types of signal sources are defined, Types 2, 3, and 4. These correspond to the number of wires used. Transmitter outputs may have various isolation among loop power source, input sensor, and 4-20mA output current. The isolation of the transmitter may impact the type of PLC input required. The Standard covers only isolated or common (single-ended) inputs. Differential inputs often used in PLCs, and connecting several current loops together, as often occurs with PLCs, are not covered well in the Standard, and often introduce additional complication regarding location of commons and grounds.
- Differential** Differential signals are measured on two wires which are separate, but not isolated from the power supply. Differential inputs allow a greater degree of freedom in wiring commons and grounds without affecting accuracy. There is a limited voltage rating (see Common Mode) between the signal level wires and the power supply wires. This limitation also applies to voltage differences among additional I/O on the same supply. Differential inputs usually come in groups sharing the supply common tie point. Some voltage outputs may have an external return or *remote sense* which allows the load common or ground to be different than the supply of the output module by a small voltage. Current loop signals are less susceptible to differences in voltage between circuit components (see compliance). Differential inputs permit series inputs with current loops, since the signal can be offset from common. Do not confuse differential inputs with isolated inputs; differential requires the common tie point reference for all inputs of the group, usually either ground or the supply common.
- Ground Loop** When a conductor is grounded in more than one place, ground potential differences can induce currents producing voltage drops in the wire. If the conductor is also used to carry an analog signal, these voltage drops produce an accuracy error or noisy values. If a single point ground is used, the voltage difference between locations may still appear in series with the desired signal. This is overcome by using differential or isolated inputs and running a separate return from the

remote source. This preserves the integrity of the signal, and the ground voltages appear as common mode voltage at the receiving end.

- Isolated** Isolated inputs are usually two-wire and are dielectrically insulated from supplies and ground. Sometimes additional connections are provided for excitation of transducers such as RTDs, but these signals are not shared with other I/O points. Isolated modules allow high voltages to exist between I/O devices and the PLC. Do not confuse isolated inputs with the isolation between groups of analog circuits, or isolation from other components of the system, such as logic or power supplies.
- Normal Mode** This is the actual signal across the signal wires of differential or isolated I/O. This may also include unwanted noise such as power line frequency pickup.
- Single-ended** Single-ended circuits have the signal measured relative to a common connection, usually the power supply. Other analog I/O signals typically share this common. Single-ended circuits require fewest terminal points, giving the highest density and lowest price, but at the cost of more restrictive wiring and errors due to voltage drops and currents in the common connections. Single-ended circuit connections are most similar to the wiring of discrete modules.
- Unipolar** The term unipolar means, literally, one pole. Unipolar signals or ranges do not change polarity during normal operation; for example 0 to 10 volts, or 4mA to 20mA. Reversed connection to a unipolar input will produce minimum value and, if diagnostics are available, underrange or open wire faults.

Appendix B

GE Fanuc Product Agency Approvals, Standards, General Specifications

efesotomasyon.com

The products supplied by GE Fanuc are global products which are designed and manufactured with ISO9001 quality assurance for application in industrial environments throughout the world. They should be installed and used in conformance with product specific guidelines as well as the following agency approvals, standards, and general specifications. The information in this appendix is also available in a separate data sheet, GFK-0867.

AGENCY APPROVALS OVERVIEW ¹		Comments
Quality Assurance in Design/Development, Production, Installation, & Servicing	ISO9001	Certification ⁴ by BSI Quality Assurance
Safety for Industrial Control Equipment	UL508	Certification by Underwriters Laboratories
	C-UL⁵, CSA22.2, or 142-M1987	Certification by Underwriters Laboratories [C-UL ⁵] or Canadian Standards Association for selected Series 90, Genius, VersaMax, and Field Control modules
Safety for Hazardous Locations Class I, Div II, A, B, C, D	UL1604 with C-UL⁵	Certification by Underwriters Laboratory for VersaMax, Field Control, and selected Series 90 and Genius modules
	FM3611	Certification by Factory Mutual for selected Genius and Series 90-70 modules
	CSA22.2, 213-M1987	Certification by Canadian Standards Association for selected Genius modules
Safety for Hazardous Locations Class I, Zone 2, A, B, C, D	CENELEC prEN50021	Certification by DEMKO through Underwriters Laboratory for selected Series 90-30 and Field Control modules, and VersaMax products
	UL2279 IEC 79-15	Certification by Underwriters Laboratory for VersaMax products, and selected Series 90-30 and Field Control modules
European EMC and Low Voltage Directives	CE Mark	Certification by Competent Body for EMC Directive for selected modules

STANDARDS OVERVIEW ^{2, 4}		Conditions
ENVIRONMENTAL		
Vibration	IEC68-2-6	1G @57-150Hz; 0.006 in p-p @10-57Hz
Shock	IEC68-2-27	15G, 11ms
Operating Temperature ³		0°C to 60°C: Series 90 [inlet], Genius [ambient], VersaMax [ambient] 0°C to 55°C: Field Control [ambient]
Storage Temperature		-40°C to +85°C
Humidity		5% to 95%, non-condensing
Enclosure Protection	IEC529	Steel cabinet per IP54: protection from dust & splashing water

STANDARDS OVERVIEW^{2, 4}		<i>Conditions</i>
EMC EMISSIONS		
Radiated, Conducted	CISPR 11/EN 55011 CISPR 22/EN 55022 47 CFR 15	“Industrial Scientific & Medical Equipment” (Group 1, Class A) “Information Technology Equipment” (Class A) referred to as FCC part 15, “Radio Devices” (Class A)
EMC IMMUNITY [applies to CE Marked modules]		
Electrostatic Discharge	EN 61000-4-2*	8KV Air, 4KV Contact
RF Susceptibility	EN 61000-4-3*	10V _{rms} /m, 80Mhz to 1000Mhz, 80% AM
	ENV 50140/ENV 50204	VersaMax: All power supply, I/O, and communication modules
Fast Transient Burst	EN 61000-4-4*	2KV: power supplies, 1KV: I/O, communication
Surge Withstand	ANSI/IEEE C37.90a IEC255-4	Damped Oscillatory Wave: 2.5KV: power supplies, I/O [12V-240V] Damped Oscillatory Wave: Class II, power supplies, I/O [12V-240V]
	EN 61000-4-5*	Field Control and VersaMax: 2 kV cm(P/S); 1 kV cm (I/O) VersaMax: All power supply, I/O, and communication modules
Conducted RF	EN 61000-4-6*	10V _{rms} , 0.15 to 80Mhz, 80%AM: comm. modules w/ cables >30m VersaMax: All power supply, I/O, and communication modules
ISOLATION		
Dielectric Withstand	UL508, UL840, IEC664	1.5KV for modules rated from 51v to 250v
POWER SUPPLY		
Input Dips, Variations	EN 61000-4-11*	During Operation: Dips to 30% and 100%, Variation for AC ±10%, Variation for DC ±20%

* EN 61000-4-x series of tests are technically equivalent to the IEC 1000-4-x and IEC 801-x series.

- Note 1:* Module specific approvals are listed on the GE Fanuc web site: GEfanuc.com/support/plc. After accessing that page, download the file Agency.zip, then extract the .xls spreadsheet containing the data.
- Note 2:* Refer to module specific data sheets & installation guidelines in the following publications:
 GFK-0600, *Series 90-70 PLC Data Sheets Manual*; GFK-0262, *Series 90-70 PLC Installation Manual*;
 GFK-0356, *Series 90-30 PLC Installation Manual*; GFK-0898, *Series 90-30 I/O Specifications Manual*;
 GEK-90486-1, *Genius I/O System User’s Manual*; GEK-90486-2, *Genius I/O Discrete and Analog Blocks User’s Manual*;
 GFK-0825, *Field Control Distributed I/O and Control System - Genius Bus Interface Unit User’s Manual*;
 GFK-0826, *Field Control Distributed I/O and Control System - I/O Module’s User’s Manual*;
 GFK-1179, *Installation Requirements for Conformance to Standards*; GFK-1503, *VersaMax System PLC Reference Manual*;
 GFK-1504, *VersaMax System I/O and Option Modules*; GFK-1535, *VersaMax System Network Communications User’s Manual*.
- Note 3:* Selected modules may be derated.
- Note 4:* Applies to GE Fanuc products designed and built in Charlottesville.
- Note 5:* Modules comply with applicable CSA Standards as evaluated by UL. The C-UL mark is accepted throughout Canada.

® Genius is a registered trademark of GE Fanuc Automation North America, Inc.
 ™ Series 90, VersaMax, and Field Control are trademarks of GE Fanuc Automation North America, Inc.

This appendix provides data sheets describing each of the Series 90-30 cable types that can be used in an I/O system. The information in these data sheets applies to I/O systems controlled by either a Series 90-30 PLC or by a PC with an installed Personal Computer Interface card.

This appendix contains the following data sheets:

- *IC693CBL300/301/302/312/313/314* – I/O Bus Expansion cables
- *IC693CBL306/307* – Extension cables (50-pin) for high-density I/O modules
- *IC693CBL308/309* – I/O Interface cable (50-pin) for high-density I/O modules
- *IC693CBL310* – OBSOLETE I/O Interface cable (24-pin) for high density I/O modules
- *IC693CBL315* – OBSOLETE I/O Interface cable (24-pin) for high-density I/O modules
- *IC693CBL321/322/323* – OBSOLETE I/O cables (24-pin) for high-density I/O modules
- *IC693CBL327/328* – I/O Interface cables (24-pin) for high-density I/O modules
- *IC693CBL329/330/331/332/333/334* – I/O Interface cables (24-pin) for high-density I/O modules

IC693CBL300/301/302/312/313/314

I/O Bus Expansion Cables

(Includes Instructions for Building Custom Length Cables)

Description

I/O bus expansion cables (IC693CBL300, 301, 312, 313, 314), called “Wye cables,” have a single male 25-pin D connector on one end and a two-headed (one male, one female) 25-pin D connector on the other end as shown in (A) of the figure. The 50 foot (15m) (IC693CBL302) cable has a single male connector on the CPU baseplate end and a single terminated male connector on the expansion baseplate end. The 3 foot cable (IC693CBL300) can also be used as a WYE adapter cable to simplify building custom length cables (see the section “Cable Application Suggestions” later in this Chapter).

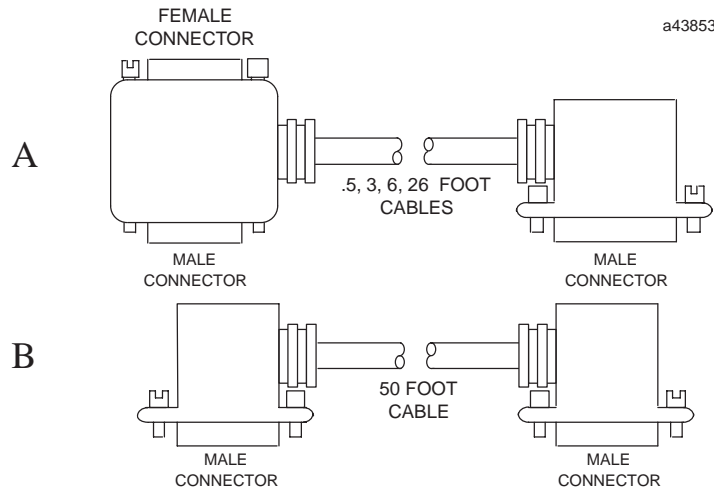

Figure B-1. Detail of I/O Bus Expansion Cables

Cable Lengths

- IC693CBL300 3 feet (1 meter), *continuous shield*
- IC693CBL301 6 feet (2 meters), *continuous shield*
- IC693CBL302 or IC693CBL314 50 feet (15 meters), *continuous shield*
- IC693CBL312 0.5 feet (0.15 meters), *continuous shield*
- IC693CBL313 25 feet (8 meters), *continuous shield*

Function of Cables

The I/O Bus expansion cables are used to extend the I/O bus to expansion or remote baseplates in a Series 90-30 I/O system when additional I/O slots are needed or baseplates are required some distance from the CPU baseplate. The prewired I/O bus expansion cables can be used for connecting either expansion or remote baseplates. Where required cable length is not available in a standard cable, a custom cable must be built (see the section “Building Custom Length I/O Bus Expansion Cables” for detailed instructions).

Connecting the Cables

- Connect the single male connector to the 25-pin female connector on the right side of the CPU baseplate.
- Connect the male connector on the dual connector end of the cable to the 25-pin female connector on the first expansion baseplate.
- Connect the unused 25-pin female connector on the dual connector end of the cable to either the single male connector of a second I/O bus expansion cable to continue the I/O bus expansion chain, or to an I/O bus Terminator plug if this is the last cable in the expansion chain.

Important Notes About I/O Bus Expansion Cables

1. The maximum number of cables that can be included in an I/O expansion system is seven, and the total maximum cable length between the CPU baseplate and the last expansion baseplate is 50 feet (15 meters). The total maximum cable length between the CPU baseplate and the last remote baseplate is 700 feet (213 meters). Failure to observe these maximum cable lengths could result in erratic operation of the PLC system.
2. CPUs 350 – 364 support a maximum of seven I/O expansion cables. CPUs 331 – 341 support a maximum of four I/O expansion cables.
3. The 50 foot (15 meter) I/O bus expansion cable (IC693CBL302), which has a male connector on each end, has the I/O bus terminating resistors built into the end connector on the cable. If this cable is used, *you would not install a separate terminator block.*

Caution

I/O Bus Expansion cables should NOT be connected or disconnected with power applied to the I/O expansion baseplate(s). Unexpected PLC operation may result.

Cable Application Suggestions

In general, it is advantageous to use standard, factory-built cables, where possible, to save time and avoid wiring errors.

Using Standard Cables

- For connecting between baseplates (either between a CPU and expansion baseplate, between two expansion baseplates or between two remote baseplates) in the same cabinet when a standard length (0.5, 1, 2, 8, or 15 meters) will fit the need.
- As a Wye jumper for custom built point-to-point cables (IC693CBL300 is often used for this). This combination saves time since a point-to-point cable can be built much faster than a Wye cable. An example of this is shown in Figure 10-23.

Using Custom Built cables

- When you need a cable length not available in a standard size.
- When a cable must be routed through a conduit that is not large enough for a standard cable's connector to fit through.

Building Custom Length I/O Bus Expansion Cables

This section provides details needed to create custom length I/O Bus Expansion cables.

Two Types of Custom Built Cables

The two types are:

- **Point-to-Point** – these have a single male connector on one end and a single female connector on the other end. These are usually used with the IC693CBL300 which supplies the Wye connection. This combination saves time since a point-to-point cable can be built much faster than a Wye cable.
- **Wye** - these have a single male connector on one end and two connectors (one male and one female) on the other end.

Components Needed to Build Custom Length I/O Bus Expansion Cables

Note: the special two-headed Wye connector used on the standard Wye cables is not available as a separate component.

Item	Description
Cable:	Belden 8107 only (no substitutes): Computer cable, overall braid over foil shield, twisted-pair 30 volt/80°C (176°F) 24 AWG (.22 mm ²) tinned copper, 7 x 32 stranding Velocity of propagation = 70% † Nominal impedance = 100Ω
25 Pin Male Connector:	Crimp Plug = Amp 207464-1; Pin = Amp 66506-9 Solder Plug = Amp 747912-2
25 Pin Female Connector:	Crimp Receptacle = Amp 207463-2; Pin = Amp 66504-9 Solder Receptacle = Amp 747913-2
Connector Shell:	Kit - Amp 745833-5: Metal-plated plastic (plastic with nickel over copper) † Crimp ring - Amp 745508-1, split ring ferrule

† = Critical Information

‡ Vendor part numbers listed for user assembled cables are provided for reference only and do not suggest or imply that they are preferred. Any part meeting the same specification can be used.

Expansion Port Pin Assignments

The following table lists the expansion port pin assignments you will need when building remote cables. All connections between cables are point-to-point, that is, pin 2 of one end to pin 2 of the opposite end, pin 3 to pin 3, etc.

Table B-1. Expansion Port Pin Assignments

Pin Number	Signal Name	Function
16	DIODT	I/O Serial Data Positive
17	DIODT/	I/O Serial Data Negative
24	DIOCLK	I/O Serial Clock Positive
25	DIOCLK/	I/O Serial Clock Negative
20	DRSEL	Remote Select Positive
21	DRSEL/	Remote Select Negative
12	DRPERR	Parity Error Positive
13	DRPERR/	Parity Error Negative
8	DRMRUN	Remote Run Positive
9	DRMRUN/	Remote Run Negative
2	DFRAME	Cycle Frame Positive
3	DFRAME/	Cycle Frame Negative
1	FGND	Frame Ground for Cable Shield
7	0V	Logic Ground

I/O Expansion Bus Termination

When two or more baseplates are cabled together in an expansion system, the I/O expansion bus must be properly terminated. The I/O bus *must be terminated* at the last baseplate in an expansion system. Each signal pair is terminated with 120 ohm, 1/4 watt resistors wired between the appropriate pins, as follows (see the above table, also):

pins 16 - 17; 24 - 25; 20 - 21; 12 - 13; 8 - 9; 2 - 3

The I/O bus termination can be done one of the following ways:

- By installing an *I/O Bus Terminator Plug*, catalog number IC693ACC307, on the last expansion baseplate (local expansion baseplate or remote baseplate) in the system. The Terminator Plug has a resistor pack physically mounted inside of a connector. The I/O Bus Terminator Plug is shipped with each baseplate; only the last baseplate in the expansion chain can have the I/O Bus Terminator Plug installed. Unused I/O Bus Terminator Plugs can be discarded or saved as spares.
- If an expansion system has only one expansion baseplate, the I/O bus can be terminated by installing as the last cable, the 50 foot (15 meter) I/O Expansion cable, catalog number IC693CBL302 or IC693CBL314. These cables have the termination resistors installed in the end that connects to the expansion baseplate connector.
- You can also build a custom cable with termination resistors wired to the appropriate pins for installation at the end of the bus.

Shield Treatment

All GE Fanuc factory made cables are made with a *continuous*, or 100% shield. This means that the braided cable shield is connected to the metal shell of the connector around the entire perimeter of the connector. This provides a low impedance path to frame ground for any noise energy that is coupled onto the cable shield.

For custom length cables made per Figure 10-18, the best noise immunity is achieved when using a metallized connector cover that makes contact with the cable's braided and foil shielding and with the connector shell on the terminating end.

Note

It is *not sufficient* to only solder the drain wire to the connector shell. It is required that the cable's shield be continuous across the entire length of the cable, including at the terminations. The figure below shows the recommended method for folding the braided shield back before inserting the cable into a metallized cover.

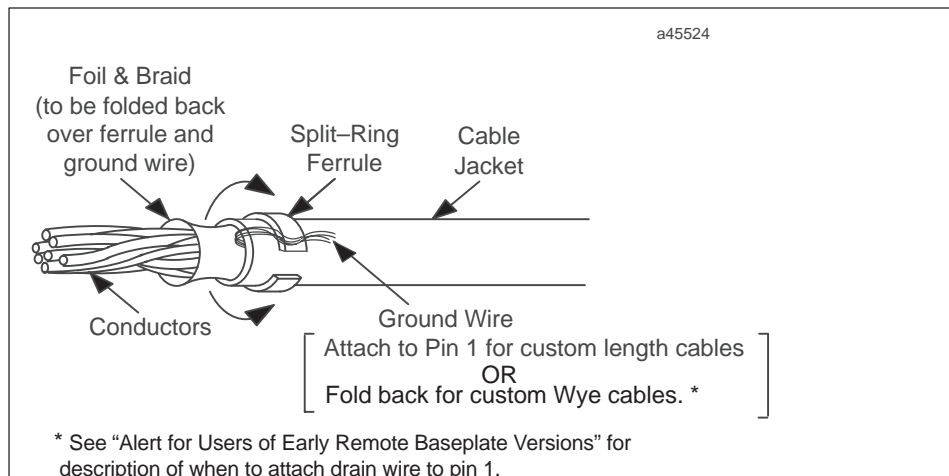

Figure B-2. How to use Split-Ring Ferrules for Foil and Braided Cable Shield

For typical industrial applications, all expansion and remote baseplate cables can be made with plastic shell covers and should be wired as shown in Figure 10-19. In either case, pin 1 should be wired into both ends of the custom length cable and the recommendations listed below should be followed for the Wye cables treatment in the remote (IC693CHS392/399) baseplates.

When using 100% shielded cables all local (CPU and expansion) baseplates in the system must be solidly referenced to the same ground point or a potential difference between baseplates could disturb signal transmission.

Alert for Users of Early Remote Baseplate Versions

In early remote baseplates versions, IC693CHS393E (and earlier) and IC693CHS399D (and earlier), it is necessary to remove pin 1 of the mating cable where the cable plugs into the baseplate. This means that when using a factory made Wye cable, such as IC693CBL300, you must break pin 1 out of the male end where it plugs into the remote baseplate before using it with one of these baseplates. *Custom built Wye cables for these baseplates should be built using Figure 10-20.*

Remote baseplates IC693CHS393F (and later) and IC693CHS399E (and later) have a change inside the baseplate which eliminates the need to remove pin 1 from the mating cable. When using factory made Wye cable with these baseplates, it is *not* necessary to remove pin 1 from the cable. Custom built Wye cables for these baseplates can be made using either Figure 10-20 or Figure 10-21. Figure 10-21 shows how the standard (factory made) Wye cables are made.

By removing pin 1 in custom built Wye cables made for the earlier versions of remote baseplates, the pin 7 (0V) signal reference originates in the main (CPU) baseplate. In these earlier versions of the remote baseplates, pin 1 was tied to pin 7 (0V) and also AC coupled to the remote frame ground. When using these baseplates in combination with the 100% shielded Wye cables, the pin 7 (0V) reference would be improperly DC coupled to the remote frame ground through the D-subminiature connector shell, which is DC coupled to the remote frame ground.

In the remote baseplates IC693CHS393F (and later) and IC693CHS399E (and later), the pin 1 shield signal is DC coupled to the remote frame ground and *not* attached to pin 7 (0V). This allows the best noise immunity by providing a good continuous cable shield, and still allows the pin 7 (0V) signal reference to originate in the CPU baseplate without the need for removing pin 1 in any factory or custom built cable. The D-subminiature connector shell is still DC coupled to the remote frame ground.

Making a 100% Shielded Cable

Use the following steps to build a 100% shielded cable:

1. Strip approximately 5/8 inch of insulation from your custom cable to expose the shield.
2. Remove the male Pin 1 from any connector plugging directly into an older version remote baseplate (IC693CHS393E, IC693CHS399D, or earlier).
3. Put split-ring ferrule over cable insulation (Figure 10-17).
4. Fold the shield back over top of the cable insulation and ferrule.
5. Place the collar of the metal hood over top of the folded shield and securely clamp the hood.
6. Test your cable for continuity between both connector shells. Connect an ohmmeter between the shells and flex the cable at both ends. If the metalized connector hood is not making proper contact with the cable shield at either end, the connection will show intermittent continuity on the ohmmeter.
7. Plug the metal hooded cable onto a remote baseplate expansion port connector or into a GE Fanuc WYE cable and securely tighten the two screws. Installing and tightening the screws will electrically connect the shield to the remote baseplate frame ground, which should in turn should be connected to earth ground as instructed in the "Installation" chapter, under the heading "Baseplate Safety Grounding."

Wiring Diagrams

The following wiring diagrams show the wiring configuration for I/O expansion system cables. Wiring diagrams are provided for both point-to-point cables and Wye cables.

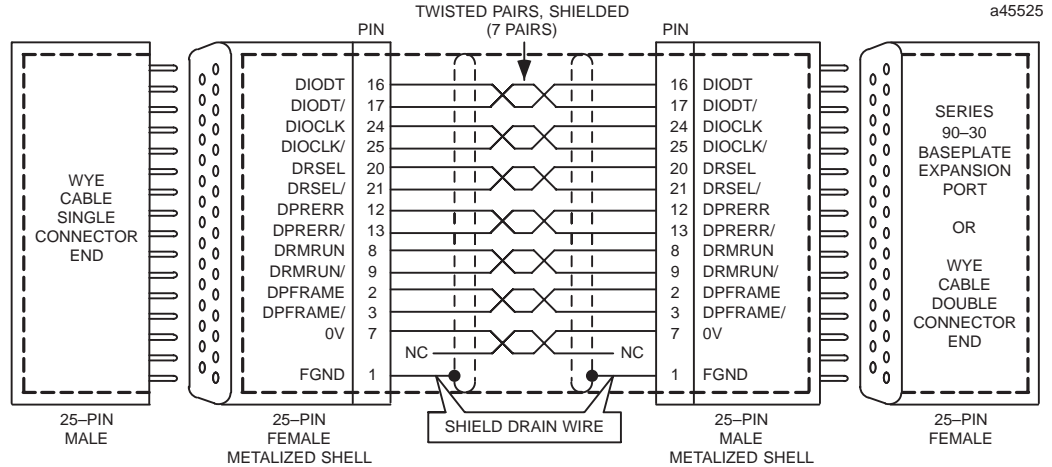

NOTE:
Bold dashed line shows continuous (100%) shielding when metalized shell connectors are plugged together.

Figure B-3. Point-To-Point Cable Wiring for Continuous Shield Custom Length Cables

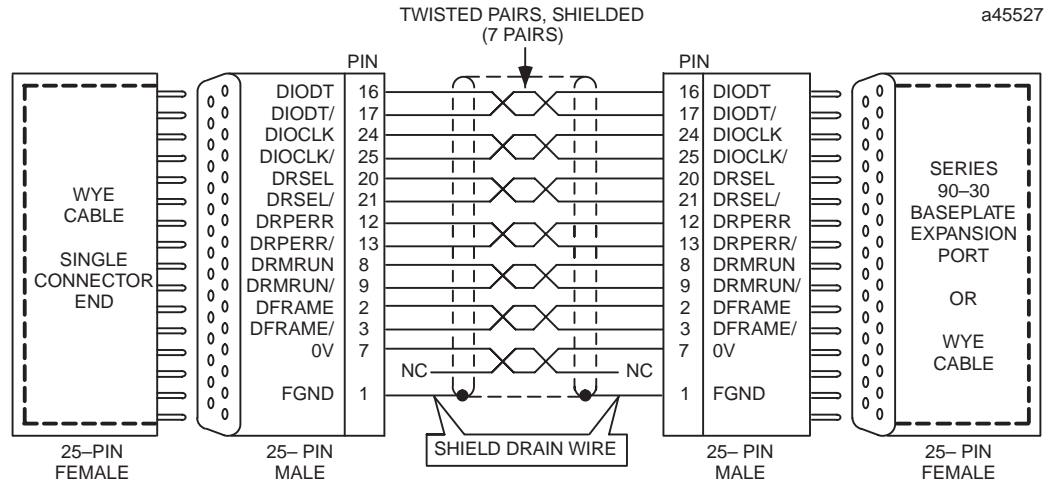
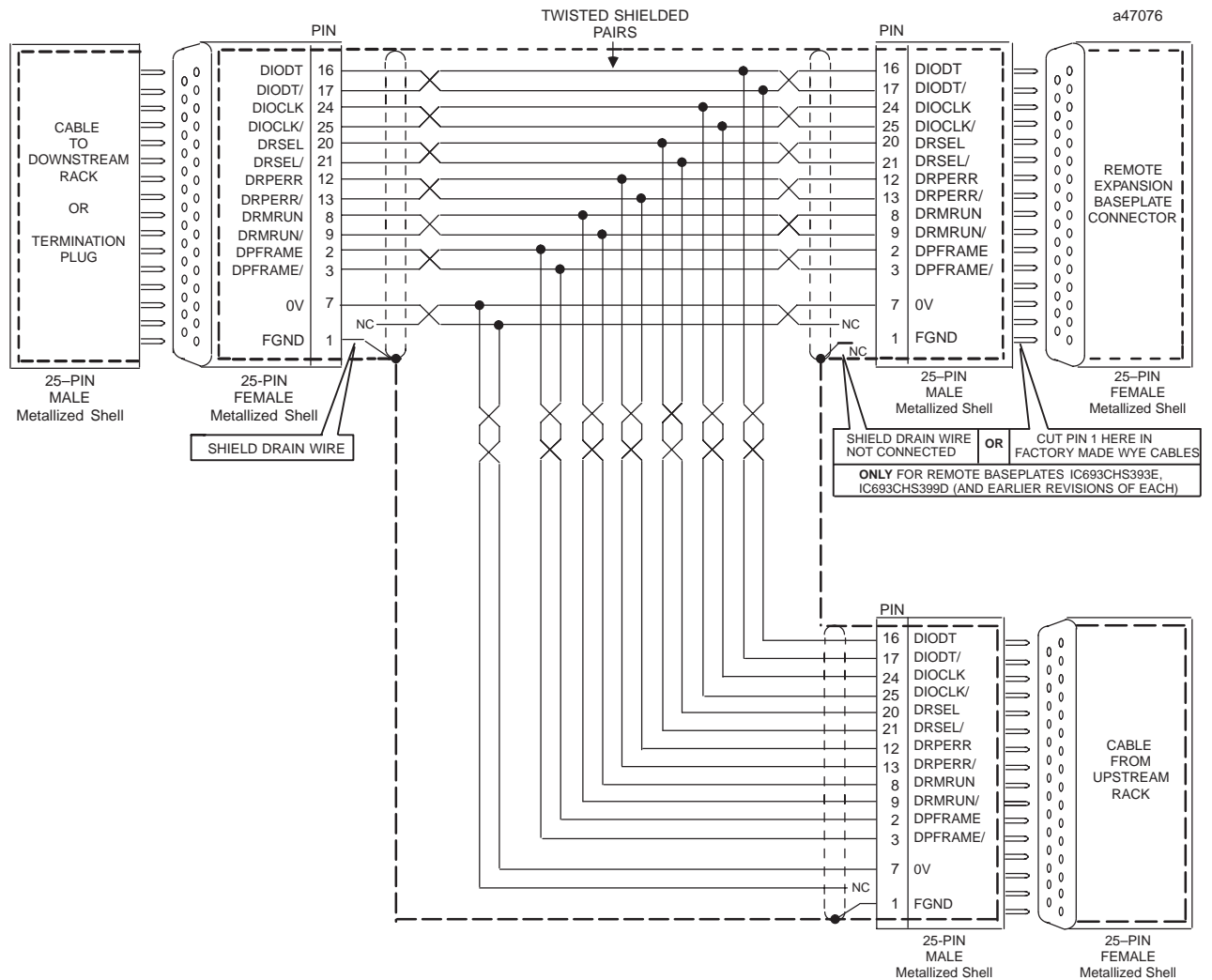

Figure B-4. Point-To-Point Cable Wiring Diagram for Applications Requiring Less Noise Immunity



NOTE:
 Bold dashed line shows continuous (100%) shielding when metallized shell connectors are plugged together.

Figure B-5. Earlier Versions of Remote Baseplate Custom WYE Cable Wiring Diagram

Note

In remote baseplates, IC693CHS393E (and earlier) and IC693CHS399D (and earlier), it is necessary to remove pin 1 of the mating cable where the cable plugs into the baseplate. This means that when using a factory made Wye cable, IC693CBL300, you must break pin 1 out of the male end where it plugs into the remote baseplate before using it with one of these baseplates. *Custom built Wye cables for these baseplates should be built using Figure 10-20.* See the section "Alert to Users of Early Remote Baseplate Versions" for more details.

Remote baseplates IC693CHS393F (and later(and IC693CHS399E (and later) have a change inside the baseplate which alleviates the need to remove pin 1 from the mating cable. When using factory made Wye cable with these baseplates, it is *not* necessary to remove pin 1 from the cable. Custom built Wye cables for these baseplates can be made using either Figure 10-20 or Figure 10-21. Figure 10-21 shows how the factory made Wye cable are made.

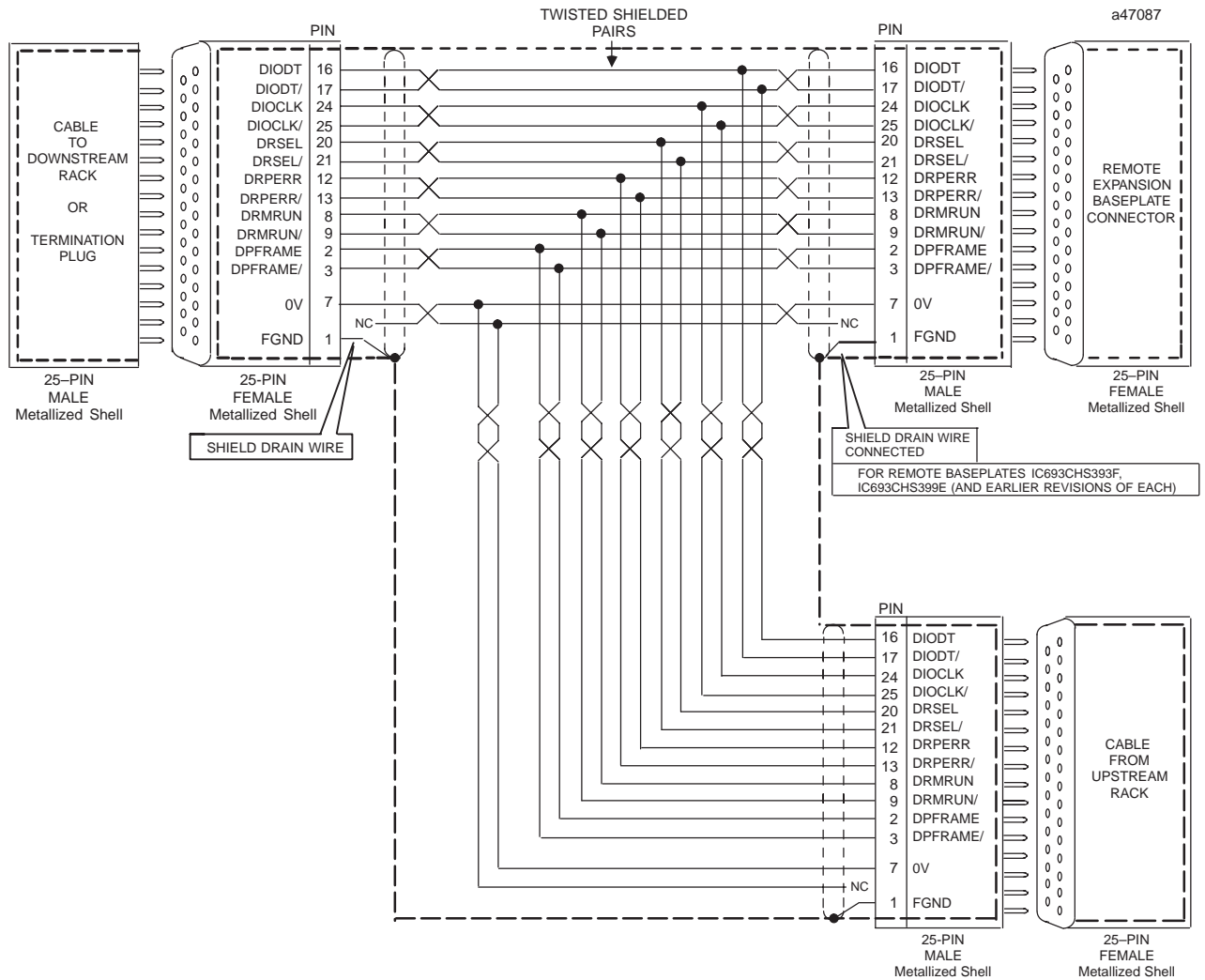

NOTE:
Bold dashed line shows continuous (100%) shielding when metallized shell connectors are plugged together.

Figure B-6. Current Remote baseplate (IC693CHS393/399) Custom Wye Cable Wiring Diagram

Application Examples

Expansion System Cable Connections

The following example shows cable connections in a system that has expansion baseplates but no remote baseplates.

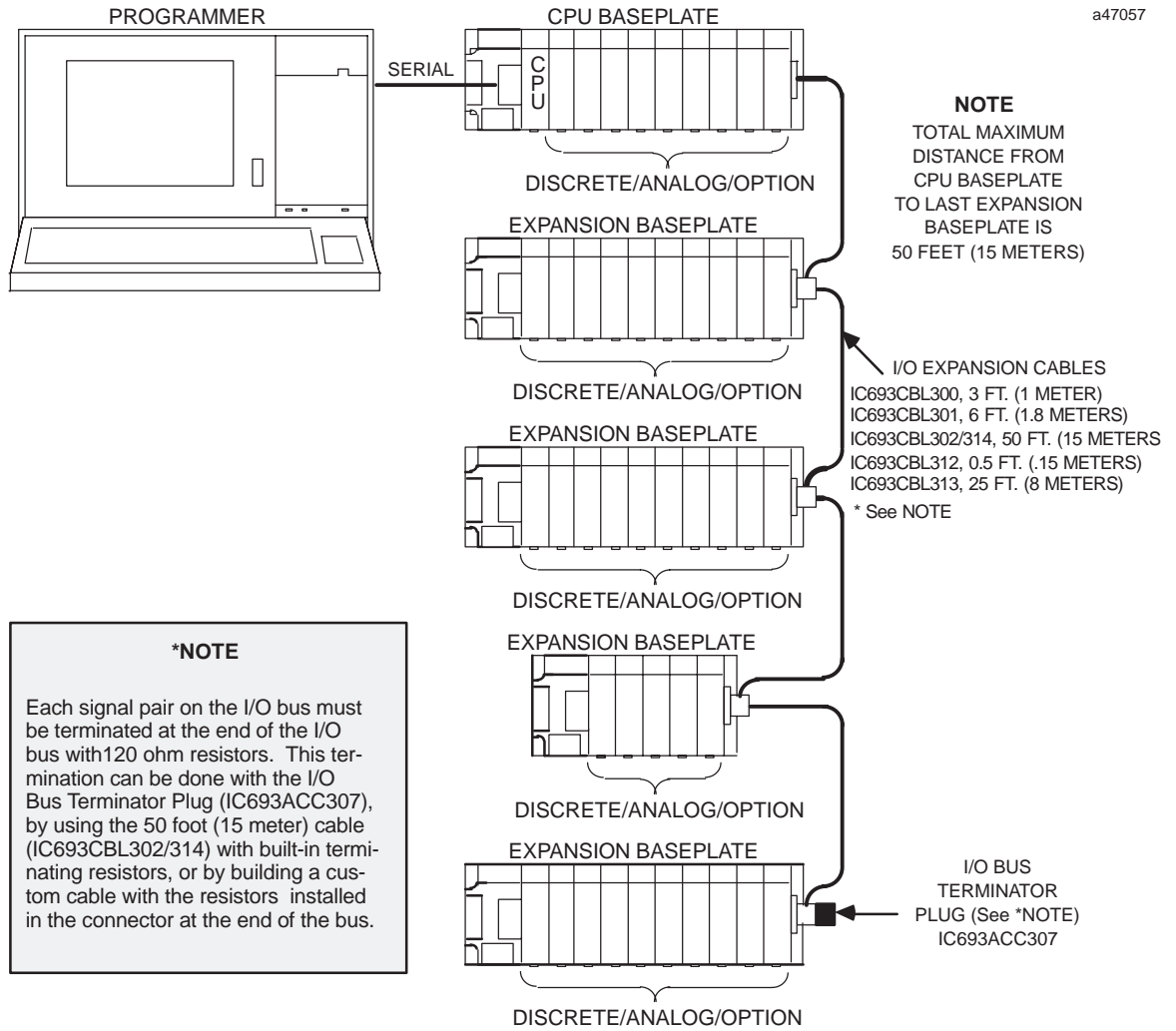

Figure B-7. Example of Connecting Expansion Baseplates

Remote and Expansion System Cable Connection Example

The following example shows cable connections in a system that includes both remote and expansion baseplates. A system can have a combination of remote and expansion baseplates as long as the distance and cable requirements are followed.

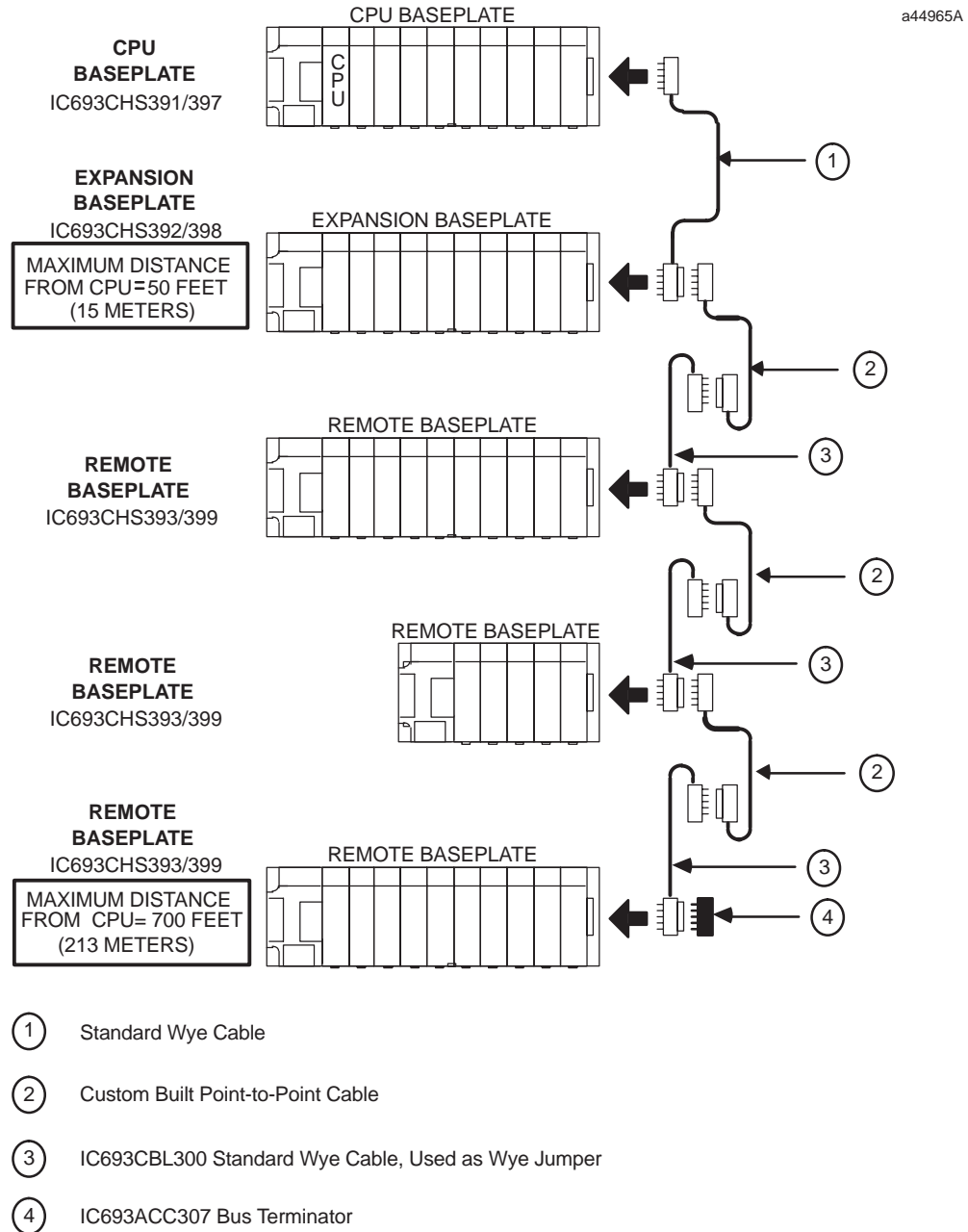

Figure B-8. Example of Connecting Expansion and Remote Baseplates

IC693CBL306/307

Extension Cables (50-Pin) for 32 Point Modules

Function of cable

This cable is used with 32 point High Density modules that have a 50-pin male Honda connector mounted on the front of the module. The extension cables have a 50-pin male connector on one end and a 50-pin female connector on the other end. This cable provides a connection from the module to a connector mounted on a DIN-rail-mounted terminal block assembly. This cable is wired pin-to-pin (That is, pin 1 to pin 1, pin 2 to pin 2, etc.). The modules that use these cables are: IC693MDL652, IC693MDL653, IC693MDL750, and IC693MDL751.

The connector on the module is oriented with the notch towards the top of the module with pin 1 at the top of the the right row of pins as you are looking at it, as shown below:

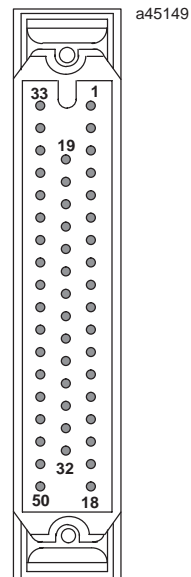

Cable Specifications

Cable Length IC693CBL306 IC693CBL307	3 feet (1 meter), 6 feet (2 meters)
Connectors	50-pin female Honda on end that connects to male connector on module. 50-pin male connector on end that connects to Connector Interface Assembly.

We recommend the use of a terminal block for connecting field wiring to the 50-pin high-density I/O modules. The use of a connector interface provides a convenient method of terminating field wiring to the modules.

Weidmuller Electrical and Electronic Connection Systems makes a suitable terminal block assembly RS-MR 50 B, catalog number 912263 (female Honda connector). An example of using an IC693CBL306 or 307 cable to connect a 32 point I/O module to one of these terminal blocks is shown in the following figure.

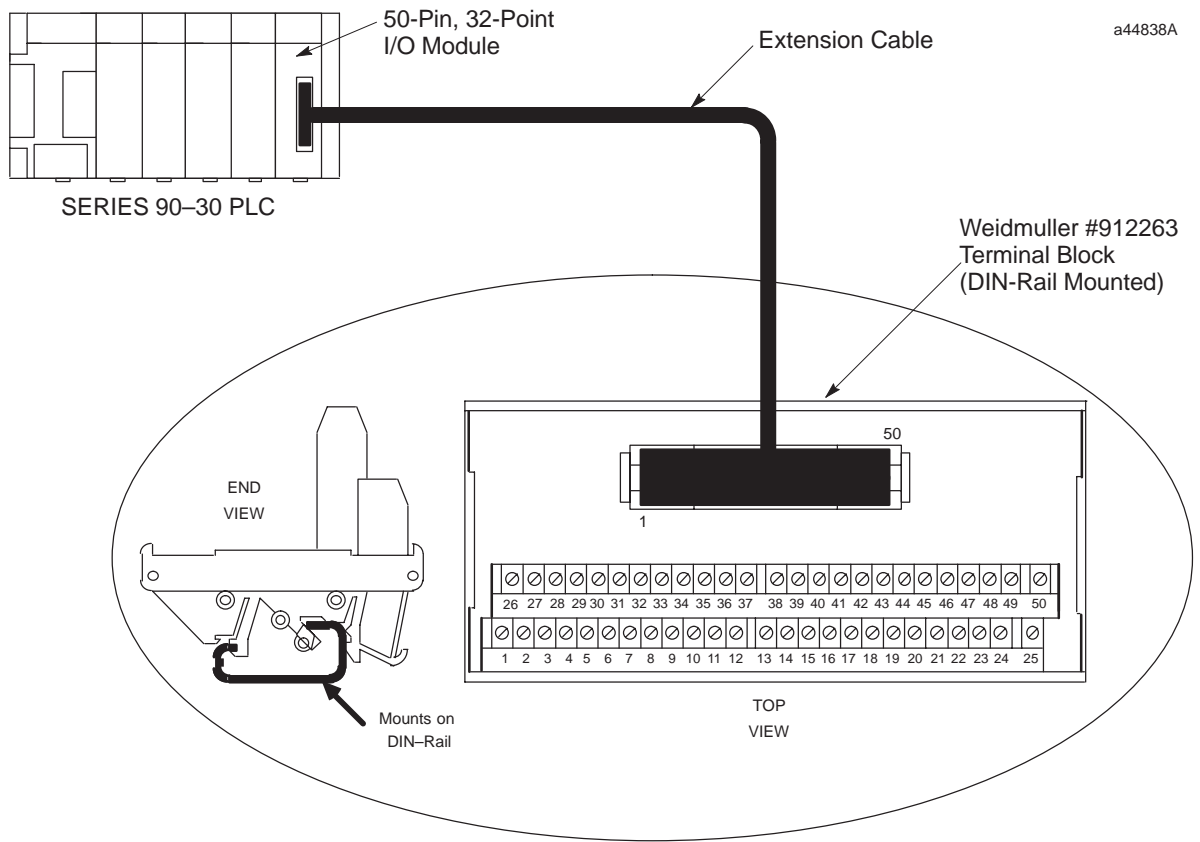

Figure B-9. 32 Point I/O Module to Weidmuller #912263 Terminal Block

IC693CBL308/309

I/O Cables (50-Pin) for 32 Point Modules

Function of cable

This cable is used with 32 point High Density modules that have a 50-pin Honda connector mounted on the front of the module. The modules that use these cable are: IC693MDL652, IC693MDL653, IC693MDL750, and IC693MDL751.

The I/O cables have a female connector on one end, and stripped and tinned wires on the other end. Each of the stripped and tinned wires has a label attached to it for ease of identification. The numbers on these labels correspond with the pin number of the connector wired to the opposite end.

Specifications

Cable Length IC693CBL308 IC693CBL309	3 feet (1 meter) 6 feet (2 meters)
Connectors	50-pin female Honda on end that connects to male connector on module. Opposite end has stripped and tinned labeled wires for connection to Connector Interface Assembly

Wiring Information

Table B-2. Wire List for 32 Point I/O Cables

Connector Pin Number	Color Code	Label Number Loose End	Connector Pin Number	Color Code	Label Number Loose End
1	Black	1	26	White/Black/Violet	26
2	Brown	2	27	White/Black/Gray	27
3	Red	3	28	White/Brown/Red	28
4	Orange	4	29	White/Brown/Orange	29
5	Yellow	5	30	White/Brown/Yellow	30
6	Green	6	31	White/Brown/Green	31
7	Blue	7	32	White/Brown/Blue	32
8	Violet	8	33	White/Brown/Violet	33
9	Gray	9	34	White/Brown/Gray	34
10	White	10	35	White/Red/Orange	35
11	White/Black	11	36	White/Red/Yellow	36
12	White/Brown	12	37	White/Red/Green	37
13	White/Red	13	38	White/Red/Blue	38
14	White/Orange	14	39	White/Red/Violet	39
15	White/Yellow	15	40	White/Red/Gray	40
16	White/Green	16	41	White/Orange/Yellow	41
17	White/Blue	17	42	White/Orange/Green	42
18	White/Violet	18	43	White/Orange/Blue	43
19	White/Gray	19	44	White/Orange/Violet	44
20	White/Black/Brown	20	45	White/Orange/Gray	45
21	White/Black/Red	21	46	White/Yellow/Green	46
22	White/Black/Orange	22	47	White/Yellow/Blue	47
23	White/Black/Yellow	23	48	White/Yellow/Violet	48
24	White/Black/Green	24	49	White/Yellow/Gray	49
25	White/Black/Blue	25	50	White/Green/Blue	50

IC693CBL310

I/O Interface Cable (24-Pin) for 32 Point Modules

Note: This cable is obsolete. Please use IC693CBL327 and IC693CBL328. See the data sheet for these cables for details. The replacement cables have right-angle connectors to reduce the clearance space required in front of the PLC.

Function of cable

This 10' (3 meter) prewired cable was used with all Series 90-30 high-density (32 point) I/O modules that use the Fujitsu 24-pin user I/O connector. Each of these modules has two of these connectors mounted side-by-side. I/O Interface cables have a 24-pin female connector on one end for connection to the module, and stripped and tinned wires on the other end. Catalog numbers for 32 point modules having two 24-pin connectors are: IC693MDL654, IC693MDL655, IC693MDL752, and IC693MDL753.

Connections to module input circuits are made from the user's input devices to two male (pin-type) 24-pin connectors (Fujitsu FCN-365P024-AU) mounted on the front of the module. The connector mounted on the right of the module (front view) interfaces with groups A and B; the connector on the left side of the module interfaces with groups C and D. If a different length cable is required for connections to these modules, you can build your own cable (information on building your own cable is found in the data sheet for cable IC693CBL315).

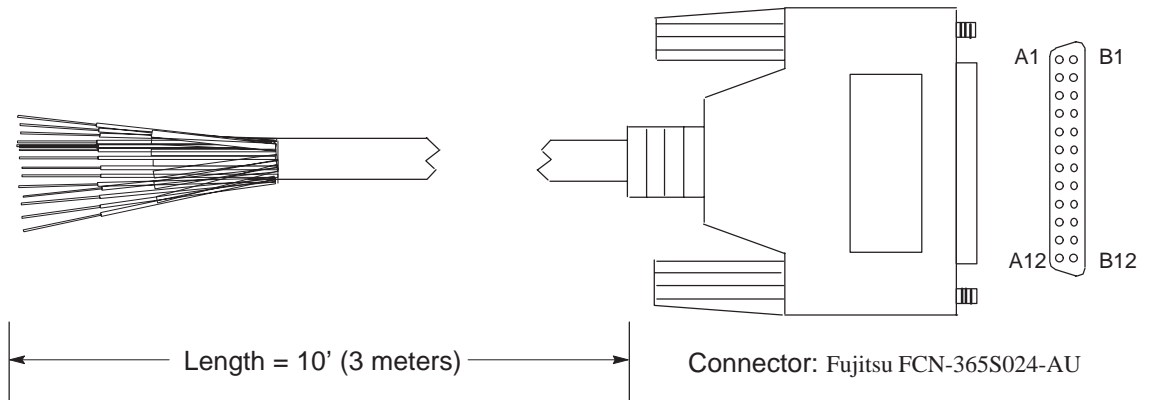
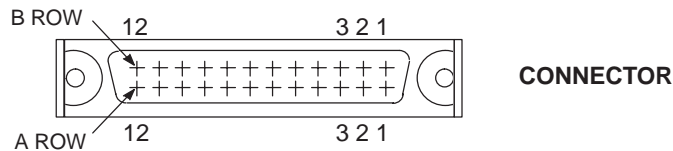

Figure B-10. IC693CBL310 Cable

Table B-3. Wire List for 24-Pin Connectors

Pin Number	Pair #	Wire Color Code	Pin Number	Pair #	Wire Color Code
A1	1	BLACK	B1	7	BLUE
A2	1	WHITE	B2	7	WHITE
A3	2	BROWN	B3	8	VIOLET
A4	2	WHITE	B4	8	WHITE
A5	3	RED	B5	9	GRAY
A6	3	WHITE	B6	9	WHITE
A7	4	ORANGE	B7	10	BROWN
A8	4	WHITE	B8	10	BLACK
A9	5	YELLOW	B9	11	RED
A10	5	WHITE	B10	11	BLACK
A11	6	GREEN	B11	12	ORANGE
A12	6	WHITE	B12	12	BLACK



NOTE

Each pair of wires should be tied together with heat shrink tubing for identification purposes. For example, a short piece of heat shrink tubing should be placed around the BLACK and WHITE wire pair (Pair #1) that connect to Pins A1 and A2, etc.

Replacement/Obsolescence Information

- This cable became obsolete and was replaced by cable IC693CBL315 (now obsolete also). The only difference between these two cables is in the wire color coding.
- When cable IC693CBL315 became obsolete, the replacement for these cables became IC693CBL327 and IC693CBL328. Cables IC693CBL310/315 have straight connectors. Cables IC693CBL327/328 have right angle connectors. The right angle connectors require less depth in front of the PLC, so allow the use of a smaller enclosure in some applications.
- Data sheets for cables IC693CBL315 and IC693CBL327/328 can be found in this chapter.

Connector Depth for Cable IC693CBL310

The following illustration shows the space required in front of the PLC when this cable is connected to a module. The depth of the cabinet that the PLC is mounted in should allow for the depth added by this connector.

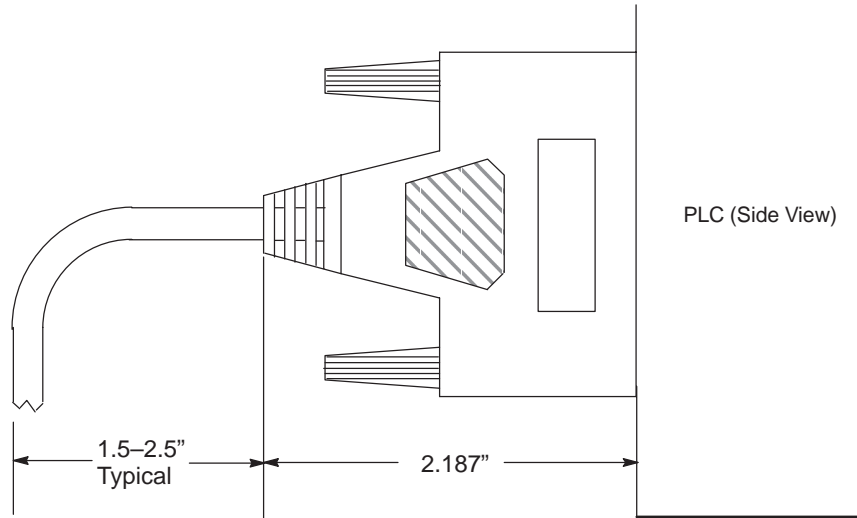

Figure B-11. Dimensions for Depth of Connector in front of PLC

IC693CBL315

I/O Interface Cable (24-Pin) for 32 Point Modules

Note: This cable became obsolete in late 1998. It was replaced by two cables: IC693CBL327 and IC693CBL328. See the data sheet for these cables for details. The replacement cables have right-angle connectors to reduce the clearance space required in front of the PLC.

Function of cable

This prewired cable is available for use with all Series 90-30 high-density (32 point) I/O modules that use the Fujitsu 24-pin user I/O connector. Each of these modules has two of these connectors mounted side-by-side. I/O Interface cables have a 24-pin connector on one end for connection to the module, and stripped and tinned wires on the other end. Catalog numbers for 32 point modules having two 24-pin connectors are: IC693MDL654, IC693MDL655, IC693MDL752, and IC693MDL753.

Connections to input circuits are made from the user's input devices to two male (pin-type) 24-pin connectors (Fujitsu FCN-365P024-AU) mounted on the front of the module. The connector mounted on the right of the module (front view) interfaces with groups A and B; the connector on the left side of the module interfaces with groups C and D. If a different length cable is required for connections to these modules, you can build your own cable.

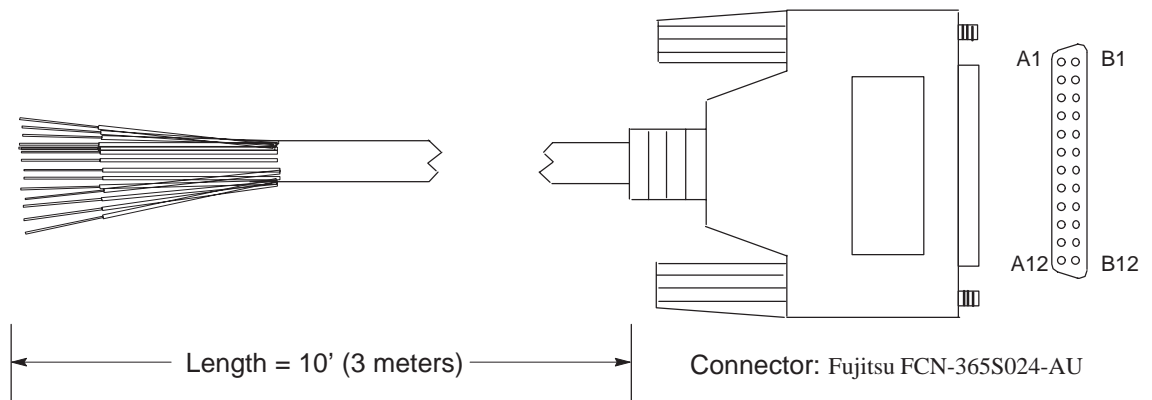

Figure B-12. IC693CBL315 Cable

Building Custom Length Cables for 24-Pin Connectors

Cables connecting the module to field devices can be built to length as required for individual applications. You must purchase the mating female (socket type) 24-pin connectors. The 24-pin connector kit can be ordered as an accessory kit from GE Fanuc. Catalog numbers for these connectors and their associated parts are listed in the following table. The list includes catalog numbers for three types of connectors: solder pin, crimp pin, and ribbon cable. *Each accessory kit contains enough components (D-connectors, backshells, contact pins, etc.) to assemble ten single-ended cables of the type specified for each kit.*

Table B-4. Catalog Numbers for 24-Pin Connector Kits

GE Fanuc Catalog Number	Vendor Catalog Number	Description
IC693ACC316 (Solder Eyelet Type)	FCN-361J024-AU	Solder eyelet receptacle
	FCN-360C024-B	Backshell (for above)
IC693ACC317 (Crimp Type)	FCN-363J024	Crimp wire receptacle
	FCN-363J-AU	Crimp pin (for above, 24 needed)
	FCN-360C024-B	Backshell (for above)
IC693ACC318 (Ribbon or IDC Type)	FCN-367J024-AUF	IDC (ribbon) receptacle, closed cover
	FCN-367J024-AUH	IDC (ribbon) receptacle, open cover

Additional tools from Fujitsu are required to properly assemble the crimped contact and ribbon cable type connectors. *The solder eyelet connectors (as provided in IC693ACC316) do not require any special tooling.*

Crimped Contact Connectors (as provided in IC693ACC317) require :

Hand Crimping Tool	FCN-363T-T005/H
Contact Extraction Tool	FCN-360T-T001/H

Ribbon Cable Connectors (as provided in IC693ACC318) require :

Cable Cutter	FCN-707T-T001/H
Hand Press	FCN-707T-T101/H
Locator Plate	FCN-367T-T012/H

These tools need to be ordered from an authorized Fujitsu distributor. Three of the largest US distributors for Fujitsu connectors are Marshall at (800)522-0084, Milgray at (800)MILGRAY, and Vantage at (800)843-0707. If none of these distributors service your area, then contact Fujitsu Microelectronics in San Jose, California, USA via telephone at (408) 922-9000 or via fax at (408) 954-0616 for further information.

It is recommended that you order any necessary connector tooling with sufficient lead time to meet your assembly requirements for these connectors. These tools are generally not stock items and can have significant lead times from distribution. If you have any further questions about this issue, please feel free to contact the GE Fanuc PLC Technical Support Hotline at 1-800-GE FANUC (1-800-433-2682), or International dial direct 804-978-6036.

Pin connections with color codes are shown in the following table. Cables are made of 12 twisted pairs; wire size is #24 AWG (0.22mm²).

Table B-5. Wire List for 24-Pin Connectors

Pin Number	Pair #	Wire Color Code	Pin Number	Pair #	Wire Color Code
A1	1	BROWN	B1	7	VIOLET
A2	1	BROWN/BLACK	B2	7	VIOLET/BLACK
A3	2	RED	B3	8	WHITE
A4	2	RED/BLACK	B4	8	WHITE/BLACK
A5	3	ORANGE	B5	9	GRAY
A6	3	ORANGE/BLACK	B6	9	GRAY/BLACK
A7	4	YELLOW	B7	10	PINK
A8	4	YELLOW/BLACK	B8	10	PINK/BLACK
A9	5	DARK GREEN	B9	11	LIGHT BLUE
A10	5	DARK GREEN/BLACK	B10	11	LIGHT BLUE/BLACK
A11	6	DARK BLUE	B11	12	LIGHT GREEN
A12	6	DARK BLUE/BLACK	B12	12	LIGHT GREEN/BLACK

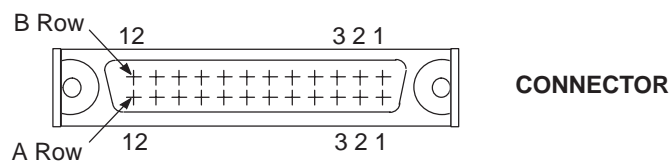

NOTE

Each wire pair has a solid color wire and that same color wire with a black tracer. For example, Pair 1 has a solid brown wire paired with a brown wire with a black tracer.

Replacement/Obsolescence Information

- Cable IC693CBL315 (now obsolete also) replaced cable IC693CBL310 when that cable became obsolete. The only difference between these two cables is in the wire color coding.
- When cable IC693CBL315 became obsolete, the replacement for these cables became IC693CBL327 and IC693CBL328. Cables IC693CBL310/315 have straight connectors. Cables IC693CBL327/328 have right angle connectors. The right angle connectors require less depth in front of the PLC, so allow the use of a smaller enclosure in some applications.

Connector Depth for IC693CBL315

The following illustration shows the space required in front of the PLC when this cable is connected to a module. The depth of the cabinet that the PLC is mounted in should allow for the depth added by this connector.

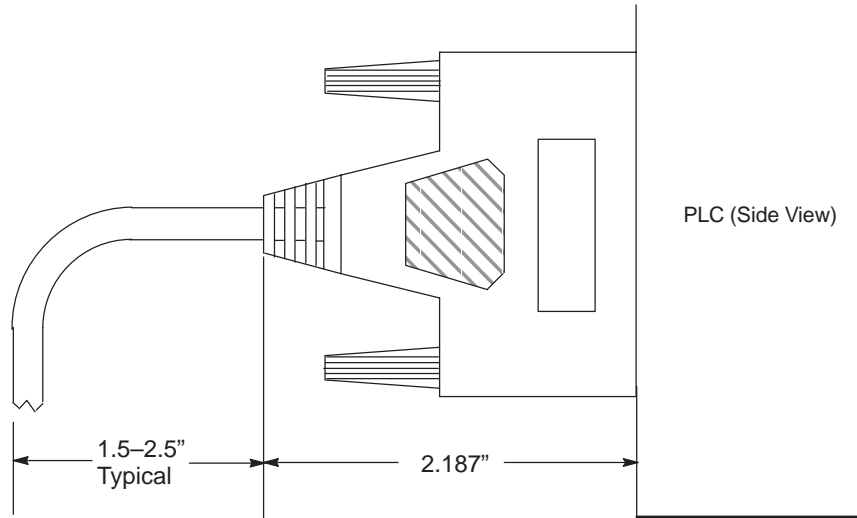

Figure B-13. Dimensions for Depth of Connector in front of PLC

IC693CBL321/322/323

I/O Faceplate Connector to Terminal Block Connector, 24-Pin

Note: These cables became obsolete in late 1998. They were replaced by six cables: IC693CBL329, IC693CBL330, IC693CBL331, IC693CBL332, IC693CBL333, and IC693CBL334. See the data sheet for these cables for details. The replacement cables have right-angle connectors to reduce the clearance space required in front of the PLC.

Function of cable

These cables are used with 16-point I/O modules that are equipped with a TBQC I/O faceplate adaptor. Each cable has a straight 24-pin female connector on both ends. Each cable provides a connection from the module to a connector mounted on a terminal block assembly. These cables are wired pin-to-pin (that is, pin A1 to pin A1, pin A2 to pin A2, etc.). An I/O faceplate assembly (catalog number IC693ACC334) is required which snaps onto the module in place of the module's standard 20-pin terminal block assembly. Five different terminal blocks are available to allow a variety of I/O modules to use this accessory (see Appendix J for details on the TBQC assemblies).

Cable Specifications

Item	Description
Cable Length † IC693CBL321 IC693CBL322 IC693CBL323	3 feet (1 meter), 6 feet (2 meters) 1.5 feet (0.5 meters)
Cable Type:	12 twisted pairs with overall aluminum polyester shield and #24 AWG drain wire.
24 Pin Female Connectors (2):	Equivalent to Fujitsu FCN-363J024, or equivalent.

† Length of cable is measured from backs of connector shells as shown in figure on next page.

The connector on the I/O faceplate is oriented as shown below, with the rows labeled A1-A12 and B1-B12. A1 and B1 are towards top of module faceplate.

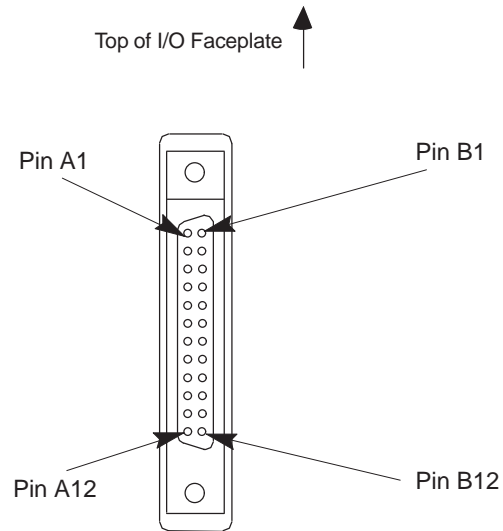
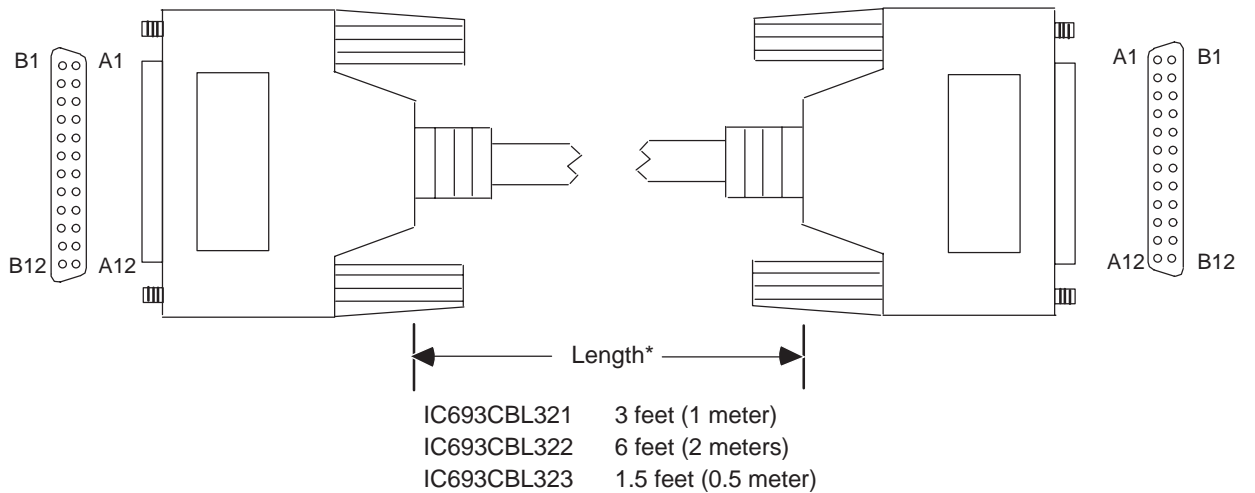

Figure B-14. Connector Orientation on I/O Faceplate



* Length is measured from backs of connector shells as shown above

Figure B-15. I/O Faceplate to Terminal Block Cable

Connector Depth

The following illustration shows the space required in front of the PLC when this cable is connected to a module. The depth of the cabinet that the PLC is mounted in should allow for the depth added by this connector.

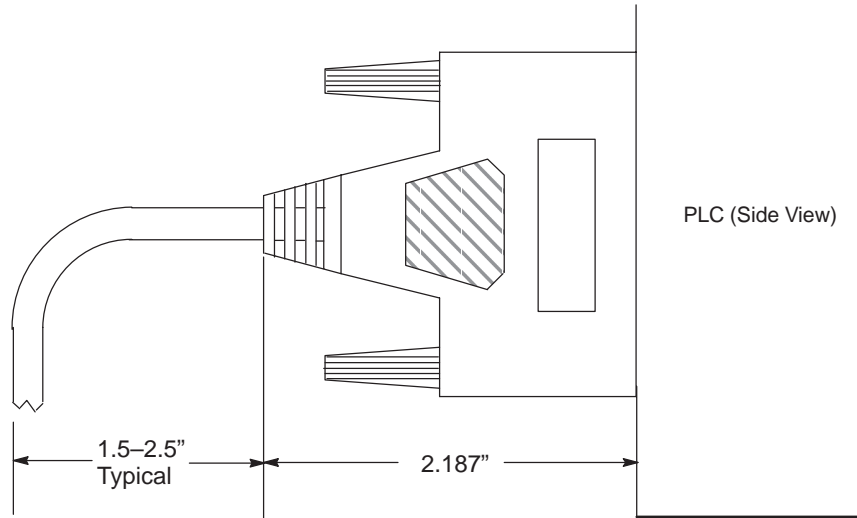

Figure B-16. Dimensions for Depth of Connector in front of PLC

IC693CBL327/328

I/O Interface Cables with Right Angle 24-Pin Connector

Note: These cables replace obsolete I/O Interface cable IC693CBL315. These replacement cables have right-angle connectors to reduce the clearance space required in front of the PLC. These replacement cables use the same pin-outs as the obsolete cables.

Description

These cables each have a right-angle 24-pin connector on one end and a set of stripped wire ends on the other. These two cables are identical except for their opposite connector orientations. This difference in the cables' connector orientations is for the purpose of matching the opposing connector orientations on the dual-connector type of 32-point I/O modules.

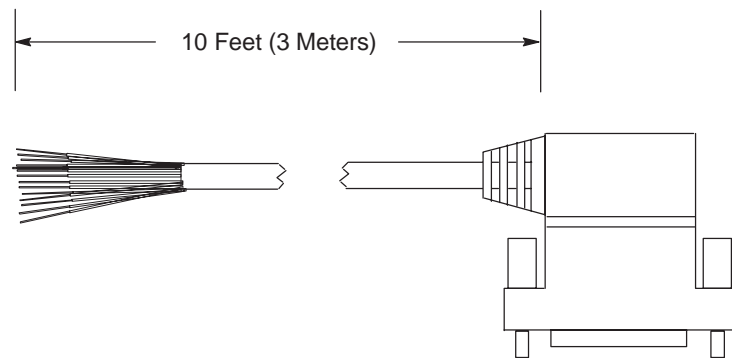

Figure B-17. IC693CBL327/328 Cables

Note

Each conductor in these 24-conductor cables has a current rating of 1.2 Amps. If using these cables with a 16-point Output module with a higher output current rating, you must use the lower value of 1.2 for the maximum load current rating. If you have field devices that require more than 1.2 Amps, do not use a TBQC assembly. Use the standard Terminal Board instead.

Applications

These cables are for use with Series 90-30 I/O modules that have the Fujitsu 24-pin user I/O connector. There are two categories of these modules:

- **32 point modules** with two 24-pin connectors (IC693MDL654, IC693MDL655, IC693MDL752, and IC693MDL753). The IC693CBL327 cable is for the modules' left side connector (front view), and the IC693CBL328 cable is for the modules' right side connector. The modules' right side connector interfaces with I/O circuit groups A and B; the modules' left side connector interfaces with groups C and D. See Chapter 7, "Input and Output Modules" for a drawing of these modules. See GFK-0898, the *Series 90-30 PLC I/O Module Specifications Manual*, for details about these modules.

- **16-point modules** that are equipped with the TBQC I/O faceplate adaptor. See Appendix J for information on the TBQC (Terminal Block Quick Connector). Use the IC693CBL328 right side cable for this application.

If a different length cable is required, you can build your own cable, but only straight connector kits are currently available. See “Building Custom Length Cables” below.

Specifications

Cable Length	10 feet (3 meters)
Connector	Fujitsu FCN-365S024-AU

Connector Depth for Cables IC693CBL327/328

The following figure shows that these cables extend 2” out from the face of the modules they are connected to. The depth of the cabinet that the PLC is mounted in should allow for the 2” depth added by this connector.

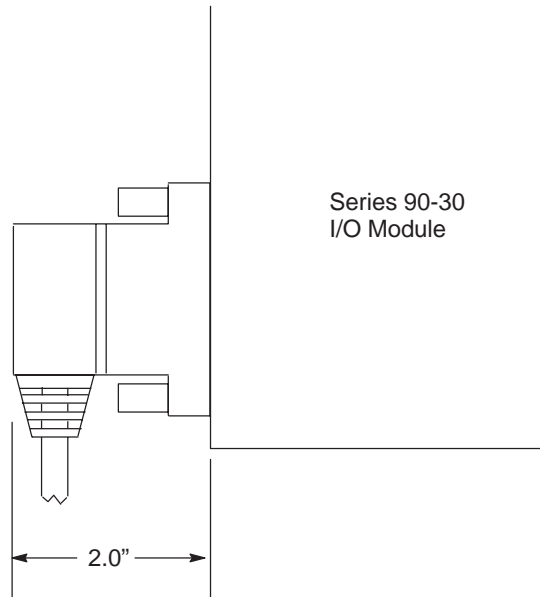

Figure B-18. Dimension for Depth of Connector for IC693CBL327/328

Building Custom Length 24-pin Connector Cables

Cables connecting the module to field devices can be built to length as required for individual applications. You must purchase the mating female (socket type) 24-pin connectors. The 24-pin connector kit can be ordered as an accessory kit from GE Fanuc. Catalog numbers for these connectors and their associated parts are listed in the following table. The list includes catalog numbers for three types of connectors: solder pin, crimp pin, and ribbon cable. *Each accessory kit contains enough components (D-connectors, backshells, contact pins, etc.) to assemble ten single-ended cables of the type specified for each kit.*

Table B-6. Catalog Numbers for 24-Pin Connector Kits

GE Fanuc Catalog Number	Vendor Catalog Number	Description
IC693ACC316 (Solder Eyelet Type)	FCN-361J024-AU	Solder eyelet receptacle
	FCN-360C024-B	Backshell (for above)
IC693ACC317 (Crimp Type)	FCN-363J024	Crimp wire receptacle
	FCN-363J-AU	Crimp pin (for above, 24 needed)
	FCN-360C024-B	Backshell (for above)
IC693ACC318 (Ribbon or IDC Type)	FCN-367J024-AUF	IDC (ribbon) receptacle, closed cover
	FCN-367J024-AUH	IDC (ribbon) receptacle, open cover

Additional tools from Fujitsu are required to properly assemble the crimped contact and ribbon cable type connectors. *The solder eyelet connectors (as provided in IC693ACC316) do not require any special tooling.*

Crimped Contact Connectors (as provided in IC693ACC317) require :

Hand Crimping Tool	FCN-363T-T005/H
Contact Extraction Tool	FCN-360T-T001/H

Ribbon Cable Connectors (as provided in IC693ACC318) require :

Cable Cutter	FCN-707T-T001/H
Hand Press	FCN-707T-T101/H
Locator Plate	FCN-367T-T012/H

These tools need to be ordered from an authorized Fujitsu distributor. Three of the largest US distributors for Fujitsu connectors are Marshall at (800)522-0084, Milgray at (800)MILGRAY, and Vantage at (800)843-0707. If none of these distributors service your area, then contact Fujitsu Microelectronics in San Jose, California, USA via telephone at (408) 922-9000 or via fax at (408) 954-0616 for further information.

It is recommended that you order any necessary connector tooling with sufficient lead time to meet your assembly requirements for these connectors. These tools are generally not stock items and can have significant lead times from distribution. If you have any further questions about this issue, please feel free to contact the GE Fanuc PLC Technical Support Hotline at 1-800-GE FANUC (1-800-433-2682), or International dial direct 804-978-6036.

Pin connections with color codes are shown in the following table. Cables are made of 12 twisted pairs; wire size is #24 AWG (0.22mm²).

Table B-7. Wire List for 24-Pin Connectors

Pin Number	Pair #	Wire Color Code
A1	1	BROWN
A2	1	BROWN/BLACK
A3	2	RED
A4	2	RED/BLACK
A5	3	ORANGE
A6	3	ORANGE/BLACK
A7	4	YELLOW
A8	4	YELLOW/BLACK
A9	5	DARK GREEN
A10	5	DARK GREEN/BLACK
A11	6	DARK BLUE
A12	6	DARK BLUE/BLACK

Pin Number	Pair #	Wire Color Code
B1	7	VIOLET
B2	7	VIOLET/BLACK
B3	8	WHITE
B4	8	WHITE/BLACK
B5	9	GRAY
B6	9	GRAY/BLACK
B7	10	PINK
B8	10	PINK/BLACK
B9	11	LIGHT BLUE
B10	11	LIGHT BLUE/BLACK
B11	12	LIGHT GREEN
B12	12	LIGHT GREEN/BLACK

a45144

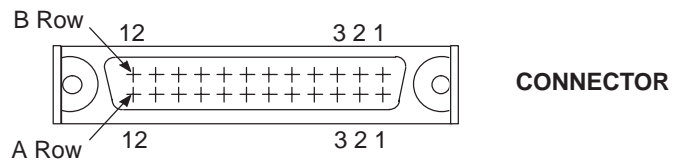

NOTE

Each wire pair has a solid color wire and that same color wire with a black tracer. For example, Pair 1 has a solid brown wire paired with a brown wire with a black tracer.

Connector Depth for Custom Built Cables

Because custom built cables use a straight connector, they require more space in front of the PLC than is required for a factory built cable, which has a right-angle connector. The following figure shows the space required in front of the PLC when this cable is connected to a module. The depth of the cabinet that the PLC is mounted in should allow for the depth added by this connector.

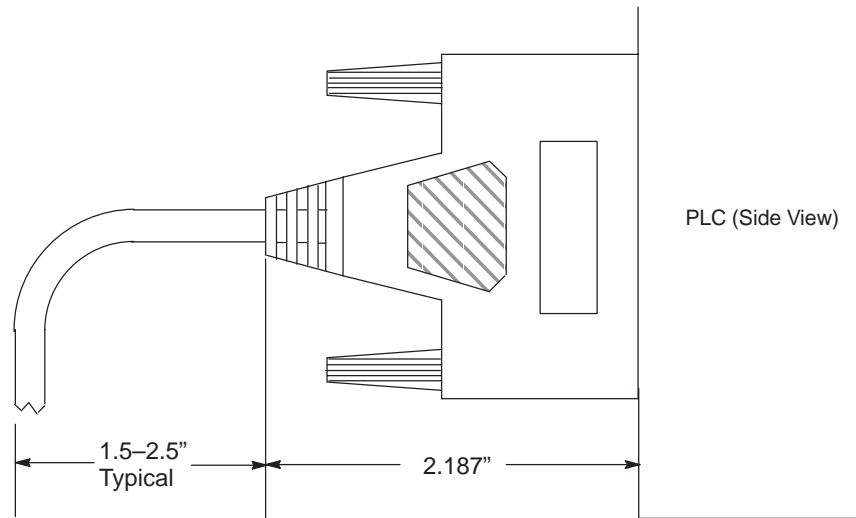

Figure B-19. Dimensions for Depth of Connector in front of PLC for Custom Built Cables

Possible Uses for These Cables (Factory or Custom Built)

- Connecting from the 24-pin connectors on a 32-point module to either a user-supplied terminal strip/block or directly to I/O field devices (switches, lights, etc.).
- Connecting from the 24-pin connector on a 16-point module that has a TBQC I/O faceplate adapter to either a user-supplied terminal strip/block or directly to I/O field devices (switches, lights, etc.). Use the right side cable, IC693CBL328, for this purpose. See Appendix J for information about TBQC (Terminal Block Quick Connect) options.
- Connecting from the 24-pin connectors on a 32-point module through a conduit to a Terminal Block Quick Connect terminal block. This can be accomplished by attaching one of the optional 24-pin connectors to the stripped end after pulling the cable through the conduit. See the section “Building Custom Length Cables” for information on the connector options. See Appendix J for information about TBQC (Terminal Block Quick Connect) options.
- Connecting from the connector on a 16-point module that has a TBQC I/O faceplate adapter through a conduit to a TBQC terminal block. This can be accomplished by attaching one of the optional 24-pin connectors to the stripped end after pulling the cable through the conduit. Use the right side cable, IC693CBL328, for this purpose. See the section “Building Custom Length Cables” for information on the connector options. See Appendix J for information about TBQC (Terminal Block Quick Connect) options.

IC693CBL329/330/331/332/333/334 Cables

24-Pin I/O Faceplate Connector to Terminal Block Connector

Note: These cables replace obsolete cables IC693CBL321/322/323. The obsolete cables had straight connectors. These replacement cables have right-angle connectors to reduce the clearance space required in front of the PLC. They use the same pin-outs as the obsolete cables.

Description

These cables all have a right-angle 24-pin connector on each end. They are identical except for connector orientation (right side and left side types) and cable length. The difference in connector orientation is to allow them to work with the dual-connector type of 32-point I/O modules. These cables are wired pin-to-pin (that is, pin A1 to pin A1, pin A2 to pin A2, etc.). Similar cables are available in a 3 meter length that have a right angle connector on one end and stripped leads on the other (see the data sheet for the IC693CBL327/328 cables for further information).

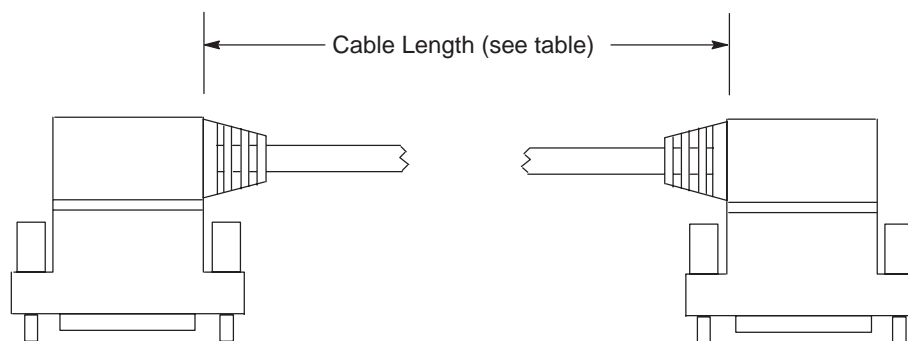

Figure B-20. IC693CBL329/330/331/332/333/334 Cables

Note

Each conductor in these 24-conductor cables has a current rating of 1.2 Amps. If using these cables with a 16-point Output module with a higher output current rating, you must use the lower value of 1.2 for the maximum load current rating. If you have field devices that require more than 1.2 Amps, do not use a TBQC assembly. Use the standard Terminal Board instead.

Table B-8. TBQC Cable Cross-Reference Table

Cable Catalog Number	Cable Description and Length	Replaces Obsolete Cable Number
IC693CBL329	Dual 24-pin, 90 deg. connectors, Left Side Cable length = 1.0 Meter	IC693CBL321
IC693CBL330	Dual 24-pin, 90 deg. connectors, Right Side Cable length = 1.0 Meter	IC693CBL321
IC693CBL331	Dual 24-pin, 90 deg. connectors, Left Side Cable length = 2.0 Meters	IC693CBL322
IC693CBL332	Dual 24-pin, 90 deg. connectors, Right Side Cable length = 2.0 Meters	IC693CBL322
IC693CBL333	Dual 24-pin, 90 deg. connectors, Left Side Cable length = 0.5 Meter	IC693CBL323
IC693CBL334	Dual 24-pin, 90 deg. connectors, Right Side Cable length = 0.5 Meter	IC693CBL323
Cable Kits		
IC693CBK002	Cable Kit. Includes both the IC693CBL329 (left side) and IC693CBL330 (right side) cables	
IC693CBK003	Cable Kit. Includes both the IC693CBL331 (left side) and IC693CBL332 (right side) cables	
IC693CBK004	Cable Kit. Includes both the IC693CBL333 (left side) and IC693CBL334 (right side) cables	

Connector Depth

The following figure shows that the cable connectors extend 2” out from the face of the Series 90-30 modules they are connected to. The depth of the cabinet that the PLC is mounted in should allow for the 2” depth added by this connector.

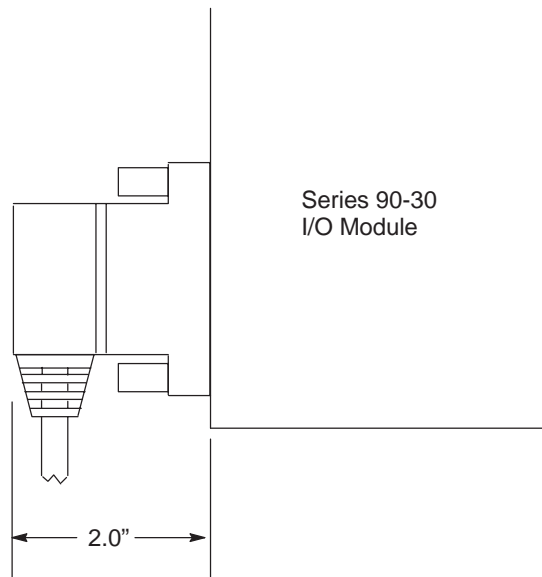

Figure B-21. Dimension for Depth of Connector

Applications

These cables connect from Series 90-30 I/O modules that use the Fujitsu 24-pin I/O connector to Terminal Block Quick Connect (TBQC) blocks. There are two categories of these modules:

- **32 point modules** with two 24-pin connectors: IC693MDL654, IC693MDL655, IC693MDL752, and IC693MDL753. The IC693CBL329/331/333 cables are for the modules' left side connector (front view), and the IC693CBL330/332/334 cables are for the modules' right side connector. The modules' right side connector interfaces with I/O circuit groups A and B; the modules' left side connector interfaces with groups C and D. The other end of the cables connect to the TBQC IC693ACC337 terminal block. See GFK-0898, the *Series 90-30 PLC I/O Module Specifications Manual*, for details about these modules. See Appendix J for information on the TBQC components.
- **16-point modules** that are equipped with the TBQC I/O faceplate adaptor. Use the IC693CBL330/332/334 right side cables for this application. See Appendix J for information on the TBQC (Terminal Block Quick Connector) components.

Appendix D

Terminal Block Quick Connect Components

efesotomasyon.com

This appendix describes the optional terminal block components for certain Series 90-30 discrete I/O modules. This system is referred to as the Terminal Block Quick Connect (TBQC) system. The advantage of this system is that it allows the listed discrete I/O modules to be quickly connected to TBQC terminal blocks. In this system, the TBQC terminal block (shown below) is snapped onto a standard DIN-rail. Then, a factory-made cable is connected between the terminal block's connector and the I/O module's connector. Some I/O modules come equipped with connectors and others have terminal boards; an I/O module that has a terminal board instead of a connector is converted into a connector type using an adapter faceplate.

NOTE: The TBQC system is not recommended for use with Analog modules because it does not meet the shielding recommendations for Analog module connections.

This appendix contains two sections, one for discrete 16-point I/O modules and one for discrete 32-point I/O modules. **For additional help in selecting TBQC components, see the topic "Terminal Block Selection Guide for Discrete I/O Modules" in Chapter 2.**

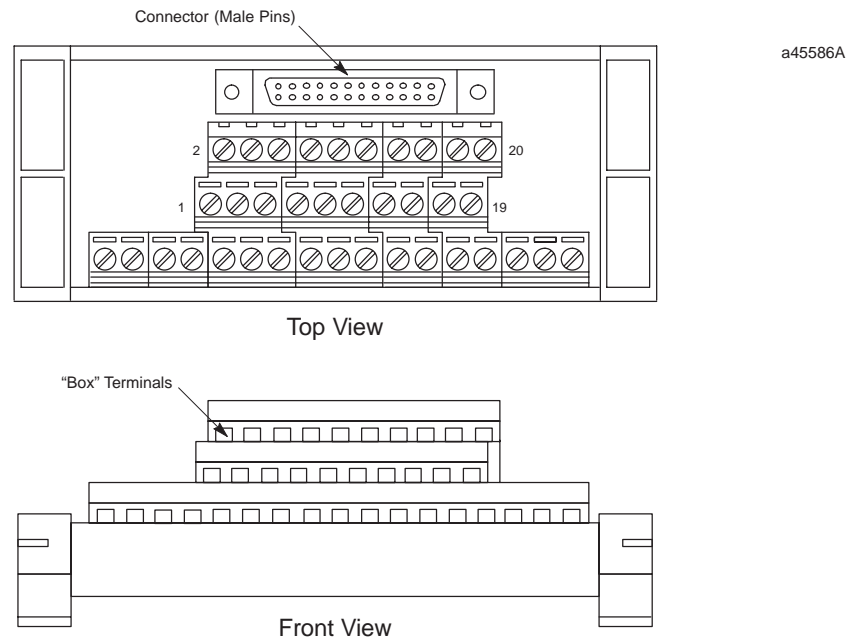

Figure C-1. Typical TBQC Terminal Block

TBQC Components for 16-Point Modules

Installing a 16 point module typically takes 2 1/2 hours to wire from a PLC to a terminal blocks or strip. With the TBQC, you simply snap the terminal block onto a DIN rail, remove the I/O module's terminal assembly, snap in the I/O faceplate, and connect the cable. This reduces wiring time to about two minutes, reducing wiring costs and errors. TBQC components consist of terminal blocks, I/O Face Plates, and cables.

Terminal Blocks

Terminal blocks have three rows of terminals, arranged in three levels, as shown in Figure J-1. These terminal blocks feature an easy to use captive-screw, "rising cage" type connection system. Catalog numbers for the terminal blocks and the modules they can be used with are listed below.

Table C-1. TBQC Terminal Block Selection Table

Catalog Number	Use With These Modules	Module Description
IC693ACC329¹	IC693MDL240 IC693MDL645 IC693MDL646	Input, 120 VAC – 16 points Input, 24 VDC Pos./Neg Logic– 16 points Input, 24 VDC Pos./Neg, Logic, FAST – 16 points
IC693ACC330	IC693MDL740 IC693MDL742	Output, 12/24 VDC Pos Logic, 0.5A – 16 points Output, 12/24 VDC Pos Logic ESCP, 1A– 16 points
IC693ACC331	IC693MDL741	Output, 12/24 VDC Neg Logic, 0.5A– 16 points
IC693ACC332	IC693MDL940	Output, Relay, N.O. – 16 points
IC693ACC333	IC693MDL340	Output, 120 VAC, 0.5A – 16 points

¹ This Terminal Block may be used with most I/O modules that have up to 16 I/O points (can not be used with 32 point modules). Jumpers may have to be added; for details of required wiring connections, refer to module specifications in this manual.

Cable Current Rating

Each conductor in these 24-conductor cables has a current rating of 1.2 Amps. If using these cables with a 16-point Output module with a higher output current rating, you must use the lower value of 1.2 Amps for the maximum load current rating . If you have field devices that require more than 1.2 Amps, do not use a TBQC assembly – use the standard Terminal Board that comes with the module instead.

Cable Selection and Cross-Reference for 16-Point Modules

Three cables are available for connecting between the module's faceplate connector and the terminal block. They can be used with any module listed in Table D-1. The only difference in these cables is their length. These cables have right-angle connectors on the module end to minimize the space required in front of the modules. These three cables replace three obsolete cables that had straight connectors. Use the following table to choose a cable:

Table C-2. TBQC Cable Selection Table for 16-Point Modules

Cable Catalog Number	Description	Replaces Obsolete Cable Number
IC693CBL330	Cable Assembly, 24-pin, 90 Deg, Right Side, 1.0 Meter length	IC693CBL321
IC693CBL332	Cable Assembly, 24-pin, 90 Deg, Right Side, 2.0 Meter length	IC693CBL322
IC693CBL334	Cable Assembly, 24-pin, 90 Deg, Right Side, 0.5 Meter length	IC693CBL323

IC693ACC334 I/O Face Plate for 16-Point Modules

The IC693ACC334 I/O Face Plate has a 24-pin connector, which provides the connection to the applicable terminal block through one of the cables listed in the table above. This face plate replaces the standard terminal board on the listed modules.

I/O Face Plate Installation

Step 1: Install terminal block assembly on DIN rail

Place the terminal block over the desired location on the DIN rail and snap into place.

Step 2: Remove 20-pin terminal assembly from module

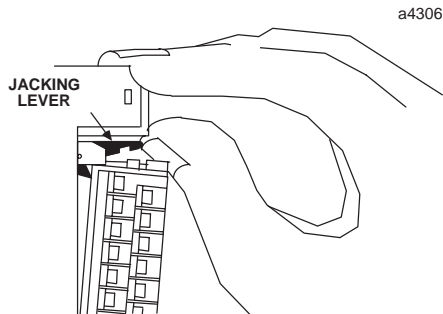

- 1 Open the plastic terminal board cover.
- 2 Push up on the jacking lever to release the terminal block.

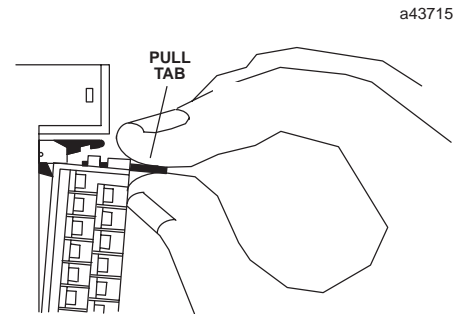

- 3 Grasp pull-tab towards you until contacts have separated from module housing and hook has disengaged for full removal.

Step 3: Snap IC693ACC334 I/O Face Plate on module

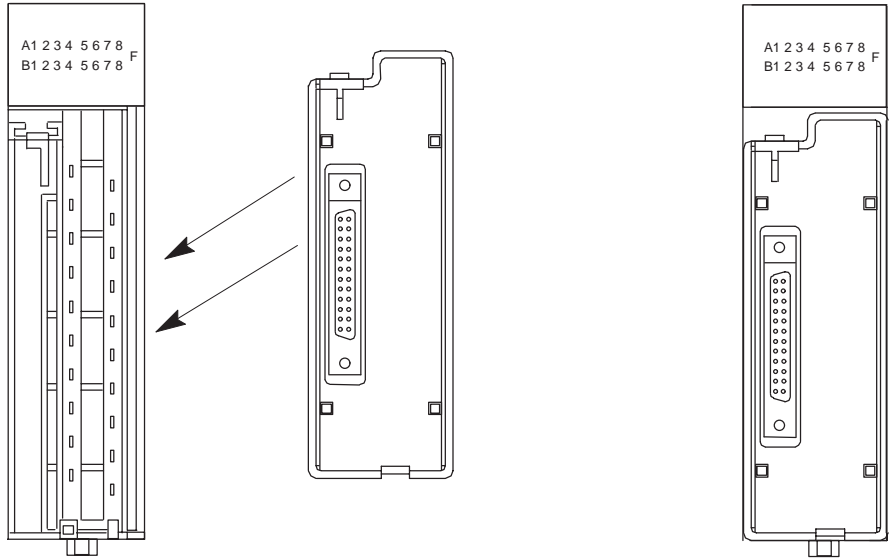

Installing the IC693ACC334 I/O Face Plate

Module with I/O Face Plate Installed

Step 4: Connect cable to connector on terminal block

Finally, connect the selected length cable from the connector on the I/O Face Plate to the connector on the interposing terminal block.

Module Wiring Information

Refer to Chapters 6 and 7 for wiring connections for each module.

Cable Information

Refer to Appendix C for cable data sheets.

Faceplate Connector Pin-Out (for 16-Point Modules)

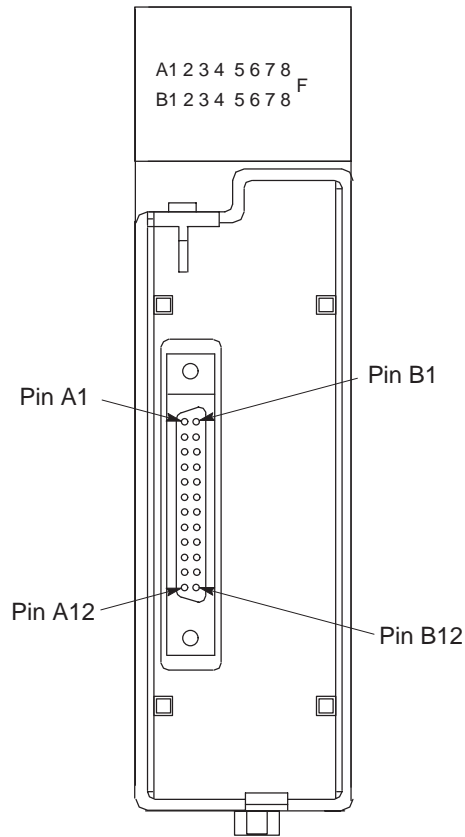

Connector Pin Orientation

a47119

Module Terminal #	Connector Pin#
1	B1
2	A1
3	B2
4	A2
5	B3
6	A3
7	B4
8	A4
9	B5
10	A5
	B6 (N.C.)
	A6 (N.C.)
	B7 (N.C.)
	A7 (N.C.)
11	B8
12	A8
13	B9
14	A9
15	B10
16	A10
17	B11
18	A11
19	B12
20	A12

Figure C-2. IC693ACC334 TBQC Faceplate

Terminal Block Information

Terminal block data sheets are found on the next several pages.

IC693ACC329 TBQC Terminal Block (for 16-Point Modules)

Use with the following 16-point I/O modules:

IC693MDL240

IC693MDL645

IC693MDL646

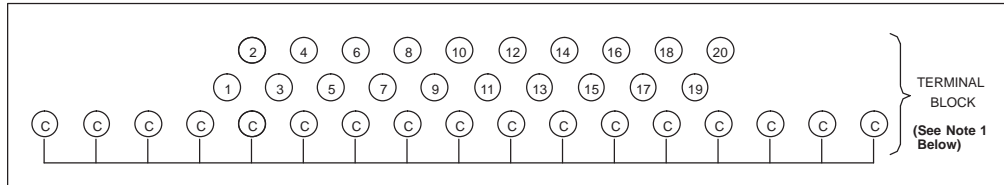
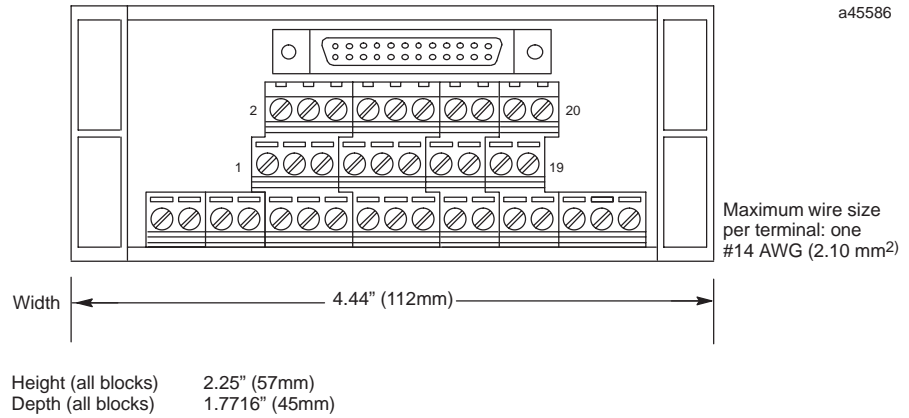

Figure C-3. IC693ACC329 TBQC Terminal Block

Note

The common row terminals (labeled with the letter C) are provided for wiring convenience. Their use is optional. They are electrically isolated from the numbered terminals. You may use them as is, or jumper them to a numbered terminal. Refer to the applicable chapter in this manual for module wiring diagrams.

Mounting

These terminal blocks are mounted on a standard, user-supplied 35 mm DIN-rail.

IC693ACC330 TBQC Terminal Block (for 16-Point Modules)

Use with the following 16-point I/O modules:

IC693MDL740

IC693MDL742

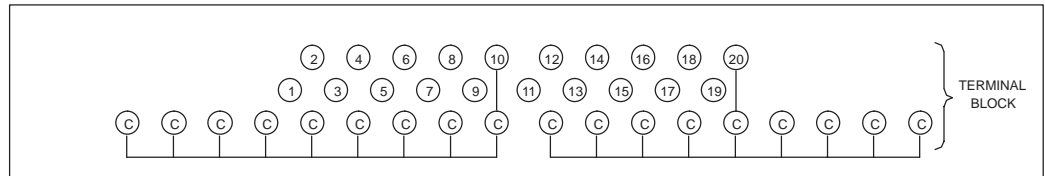
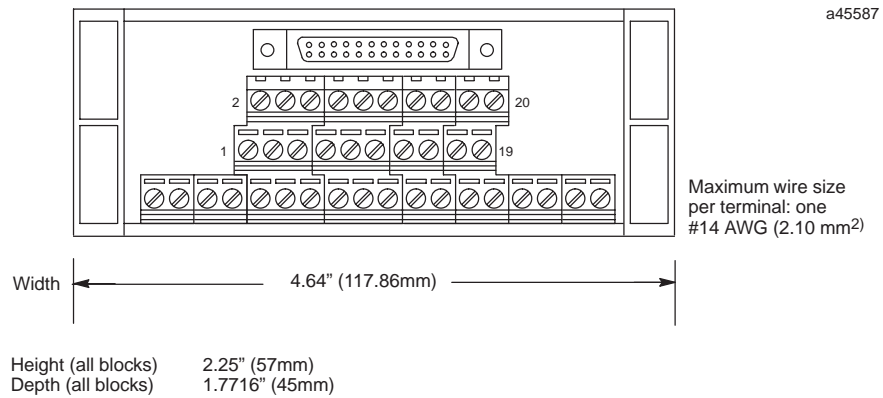

Figure C-4. IC693ACC330 TBQC Terminal Block

Note

Refer to the applicable chapter in this manual for module wiring diagrams.

Mounting

These terminal blocks are mounted on a standard, user-supplied 35 mm DIN-rail.

IC693ACC331 TBQC Terminal Block (for 16-Point Modules)

Use with the following 16-point I/O module:
IC693MDL741

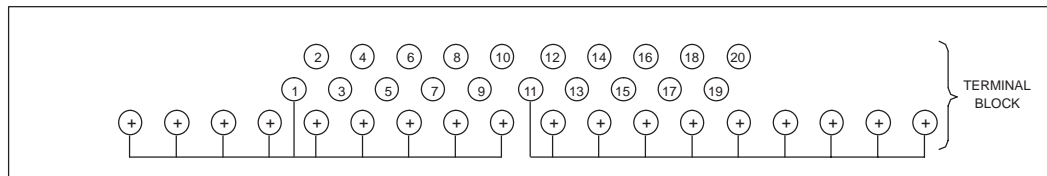
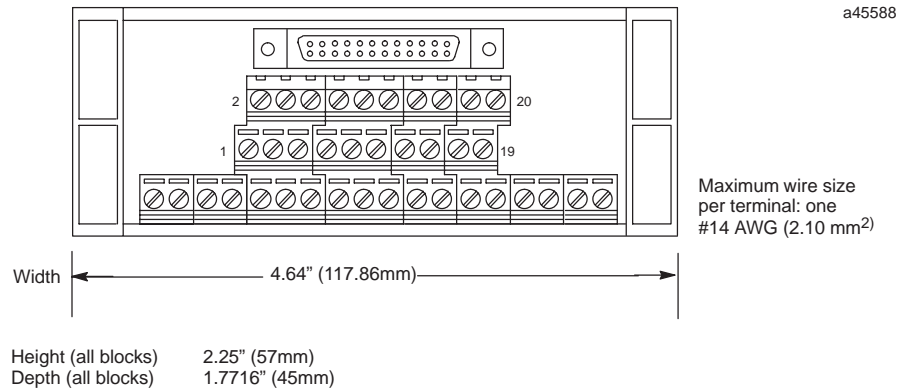

Figure C-5. IC693ACC331 TBQC Terminal Block

Note

Refer to the applicable chapter in this manual for module wiring diagrams.

Mounting

These terminal blocks are mounted on a standard, user-supplied 35 mm DIN-rail.

IC693ACC332 TBQC Terminal Block (for 16-Point Modules)

Use with the following 16-point I/O module:
IC693MDL940

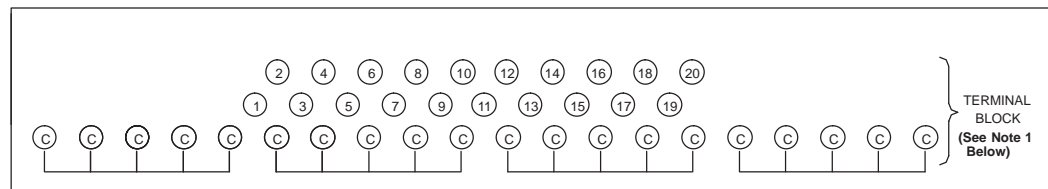
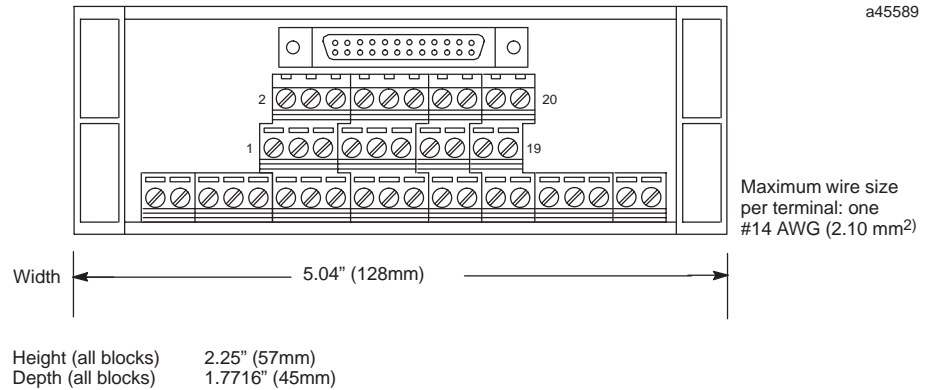

Figure C-6. IC693ACC332 TBQC Terminal Block

Note

The common row terminals (labeled with the letter C) are provided for wiring convenience. Their use is optional. They are electrically isolated from the numbered terminals. You may use them as is, or jumper them to a numbered terminal. Refer to the applicable chapter in this manual for module wiring diagrams.

Mounting

These terminal blocks are mounted on a standard, user-supplied 35 mm DIN-rail.

IC693ACC333 TBQC Terminal Block (for 16-Point Modules)

Use with the following 16-point I/O module:
IC693MDL340

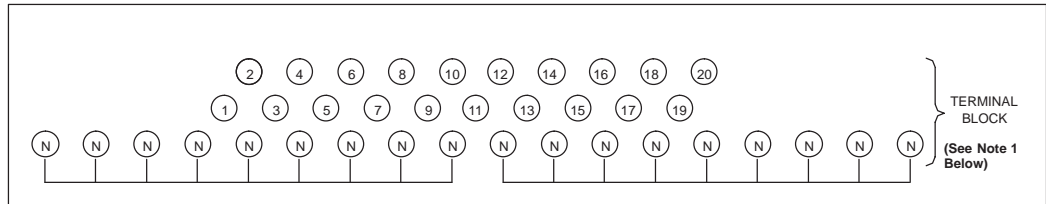
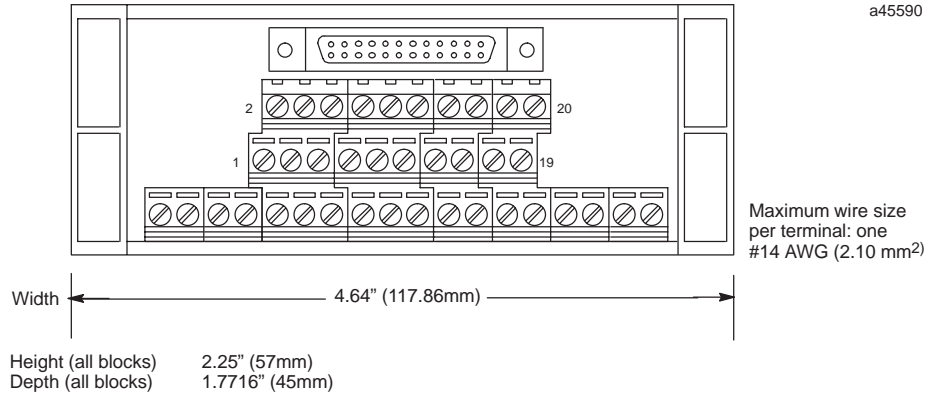

Figure C-7. IC693ACC333 TBQC Terminal Block

Note

The neutral row terminals (labeled with the letter N) are provided for wiring convenience. Their use is optional. They are electrically isolated from the numbered terminals. You may use them as is, or jumper them to a numbered terminal. Refer to the applicable chapter in this manual for module wiring diagrams.

Mounting

These terminal blocks are mounted on a standard, user-supplied 35 mm DIN-rail.

TBQC Components for 32-Point, Dual-Connector Modules

The 32-point modules do not require a new faceplate since they are equipped with a dual-connector faceplate as a standard feature. Since each module has two 24-pin connectors, they each require two cables and two terminal blocks. Also, since the modules' two connectors are oriented differently (see example in figure below), the two cables are different. One is called a "right side" cable and the other, a "left side" cable.

Note: These terminal blocks will not work with the 32-point I/O modules that have 50-pin connectors.

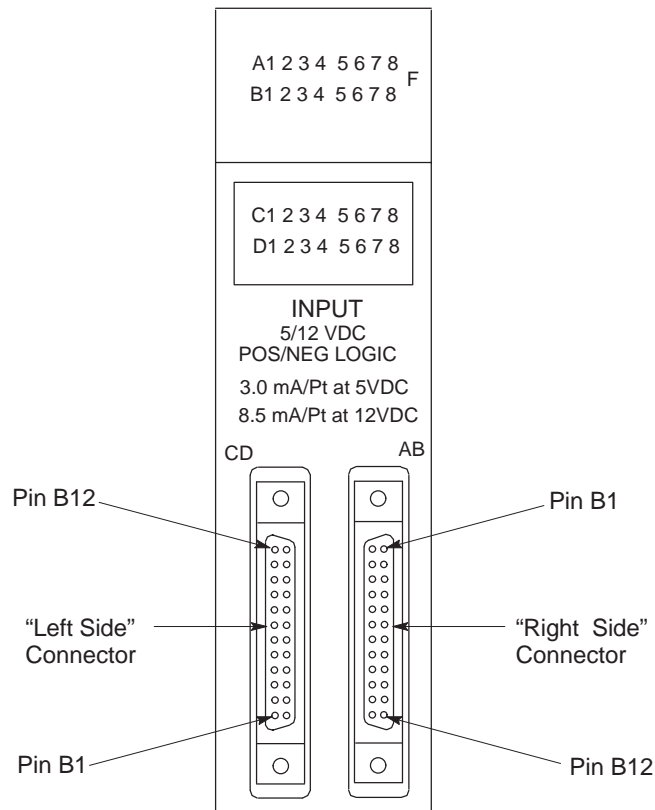

Figure C-8. Example of 32-Point, dual-connector Module (IC693MDL654)

Terminal Block

The terminal block has three rows of terminals, arranged in three levels, as shown in Figure D-1. The terminals feature an easy to use captive-screw, "rising cage" type connection system. Catalog numbers for the terminal block and the modules it can be used with are listed below.

Catalog Number	Use With These Modules	Module Description
IC693ACC337	IC693MDL654 IC693MDL655 IC693MDL752 IC693MDL753	Input, 5/12 VDC (TTL) Pos/Neg Logic– 32 points Input, 24 VDC Pos/Neg Logic – 32 points Output, 5/24 VDC Neg Logic–32 points Output, 12/24 VDC Pos Logic, 0.5A – 32 points

Cable Selection and Cross-Reference for 32-Point Modules

Six cables are available for connecting between the modules' faceplate connectors and the terminal blocks. These cables have right-angle connectors on the module end to minimize the space required in front of the modules. These six cables replace three obsolete cables that had straight connectors. Since the modules' two connectors are oriented differently (see previous figure), a right-side and left-side cable is required. Use the following table to select the correct cables. The table also lists cable kits that consist of a pair of same length, right side and left side cables.

Table C-3. TBQC Cable Selection Table for 32-Point Modules

Cable Catalog Number	Cable Description and Length	Replaces Obsolete Cable Number
IC693CBL329	Dual 24-pin, 90 deg. connectors, Left Side Cable length = 1.0 Meter	IC693CBL321
IC693CBL330	Dual 24-pin, 90 deg. connectors, Right Side Cable length = 1.0 Meter	IC693CBL321
IC693CBL331	Dual 24-pin, 90 deg. connectors, Left Side Cable length = 2.0 Meters	IC693CBL322
IC693CBL332	Dual 24-pin, 90 deg. connectors, Right Side Cable length = 2.0 Meters	IC693CBL322
IC693CBL333	Dual 24-pin, 90 deg. connectors, Left Side Cable length = 0.5 Meter	IC693CBL323
IC693CBL334	Dual 24-pin, 90 deg. connectors, Right Side Cable length = 0.5 Meter	IC693CBL323
Cable Kits		
IC693CBK002	Cable Kit. Includes both the IC693CBL329 (left side) and IC693CBL330 (right side) cables	
IC693CBK003	Cable Kit. Includes both the IC693CBL331 (left side) and IC693CBL332 (right side) cables	
IC693CBK004	Cable Kit. Includes both the IC693CBL333 (left side) and IC693CBL334 (right side) cables	

Cable Current Rating

Each conductor in these 24-conductor cables has a current rating of 1.2 Amps, which is more than adequate to handle the current requirement of any of the 32-point I/O modules listed in the table on the previous page.

Module and Cable Data

Module connection data is found in Chapters 6 and 7, and cable data is found in Appendix C.

Terminal Block Data

Only the IC693ACC337 terminal block can be used with 32-point modules. Data for this terminal block is found on the next page.

IC693ACC337 TBQC Terminal Block (for 32-Point Modules)

Use with the following 32-point I/O modules (2 terminal blocks required per module):

IC693MDL654
 IC693MDL655
 IC693MDL752
 IC693MDL753

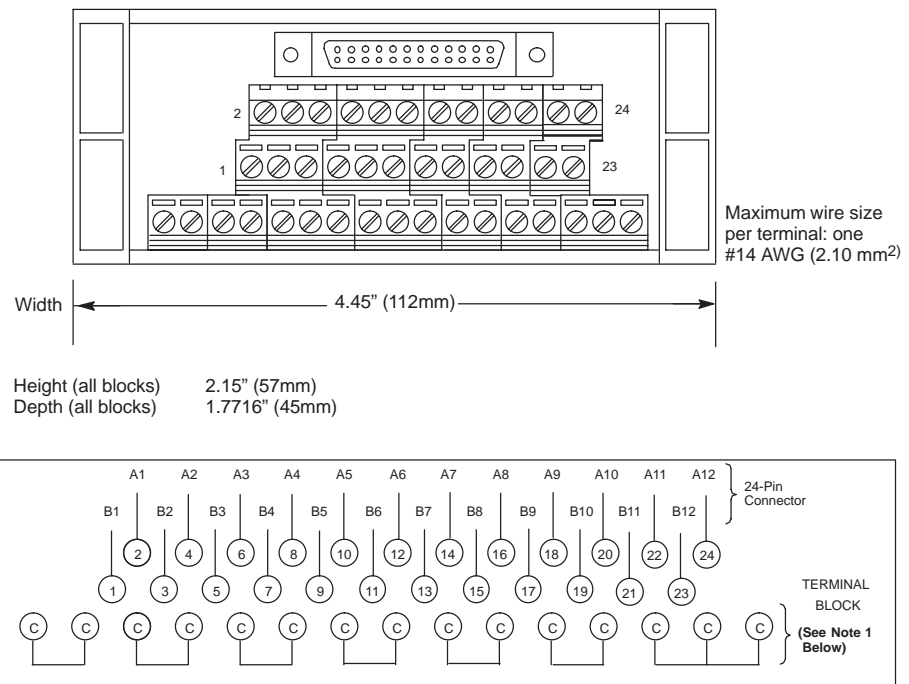

Figure C-9. IC693ACC337 TBQC Terminal Block

Note

The common row terminals (labeled with the letter C) are provided for wiring convenience. Their use is optional. They are electrically isolated from the numbered terminals. You may use them as is, or jumper them to a numbered terminal. Refer to the applicable chapter in this manual for module wiring diagrams.

Mounting

These terminal blocks are mounted on a standard, user-supplied 35 mm DIN-rail.

IC693PIF301/400 Personal Computer Interface (PCIF) Cards

These two Personal Computer Interface cards (PCIF and PCIF2) provide an alternative method of controlling Series 90-30 I/O. Either card can be used in place of a Series 90-30 PLC CPU. These ISA-compatible cards can be installed in any IBM-PC/AT ISA bus computer. The cards are implemented using computer language software (for example, C), or PC control software, such as Total Control Products' FrameworkX Automation Software.

Table D-1. Personal Computer Interface Card Comparison Table

ITEM	PCIF	PCIF2
Catalog Number	IC693PIF301	IC693PIF400
Amount of I/O controlled	1,280 bytes	25,886 bytes
Number of Series 90-30 racks controlled	Up to four Expansion or Remote racks	Up to seven Expansion or Remote racks
Slot requirement	IBM-PC/AT ISA, 8-bit, half size	IBM-PC/AT ISA, 16-bit, full size
Documentation	GFK-0889 (IPI)	GFK-1540 (data sheet)

Both of these PCIF cards have a 25-pin I/O expansion connector that connects to standard Series 90-30 Expansion and Remote baseplates (see the "Baseplates" chapter) via I/O expansion cabling. Remote racks can be located up to 700 feet (213 meters) and Expansion racks up to 50 feet (15 meters) from the personal computer. Several standard prewired I/O expansion cables are available from GE Fanuc. Alternately, custom length cables can be built. Please refer to Appendix C of this manual for information on standard and custom I/O expansion cables.

These cards also provide connections to an internal watchdog-supervised RUN output relay contact. This contact is closed under normal operating conditions, but opens if the computer or software application fails, which makes it useful for interfacing with external safety circuits.

These cards support all Series 90-30 discrete and analog I/O modules (except 16-channel analog modules). A variety of *smart* modules from Horner Electric, Inc. are also supported.

NOTE: The Programmable Coprocessor Modules, Communications Control module, Alphanumeric Display Coprocessor module, and the State Logic Processor module *are currently NOT supported by the Personal Computer Interface (PCIF) cards.*

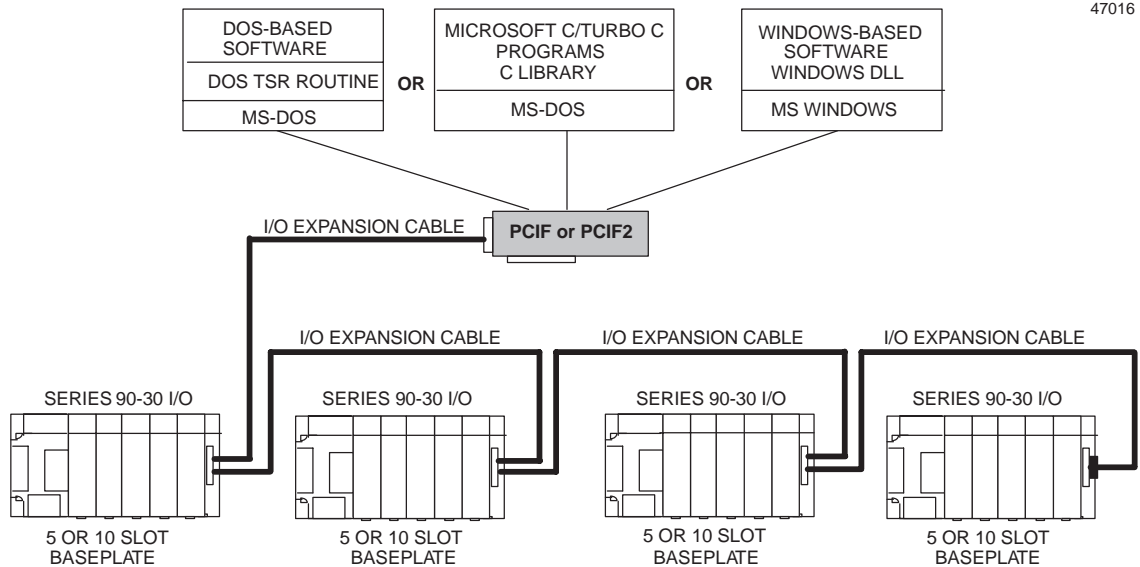

Figure D-1. Example of PCIF Interface to Series 90-30 I/O

Software

GE Fanuc’s *PC Control* software package, which runs under Windows® NT, allows you to configure and create application programs for your system. See GFK-1424, *Using PC Control Software*.

A *C Language Interface* software product, available from Horner Electric, works with both Borland Turbo C and Microsoft C. The source code for this interface is available from Horner Electric (catalog number HE693SRC844). Visit Horner Electric on the web at:

www.hornerelectric.com

Documentation

Documentation for these PCIF cards is noted in the table above; additional user documentation is available from Horner Electric, Inc. Documentation on the GE Fanuc PC Control software is found in the manual *Using PC Control Software*, GFK-1424.

Most PLCs are mounted in an enclosure. The enclosure should be capable of properly dissipating the heat produced by all of the devices mounted inside it. This appendix describes how to calculate heat dissipation for a Series 90–30 PLC. The strategy is to calculate a heat dissipation value, in Watts, for each individual module in the PLC. Then these individual values will be added together to obtain a total heat dissipation figure for the PLC. When making your calculations, don't forget the following:

- To convert percent to a decimal, move the decimal two places to the left. For example, 40% would be expressed as 0.40, and 100% would be 1.00.
- To convert milliamps (mA) to Amperes (A or Amps), move the decimal three places to the left. For example, 10mA would convert to .010A, and 130mA would convert to 0.130A.

Step 1: Basic Method to Calculate Module Dissipation

Note that this step does not apply to Power Supply Modules, which are covered in Step 2. The values needed for this calculation are found in the “Load Requirements” table in the “Calculating Power Supply Loading” section in Chapter 4 (“Power Supplies”). We will use the basic electrical power formula in these calculations

$$\text{Power (in Watts)} = \text{Voltage (in Volts)} \times \text{Current (in Amps)}.$$

We will assume that all input power to these modules is eventually dissipated as heat. The procedure is:

- Look up the module in the “Load Requirements” table (Chapter 4) and obtain the current values for each of the three power supply voltages listed. The voltage is printed at the head of each column. All modules use the 5VDC supply, and a relatively few modules also use one or both of the two 24VDC supplies.
- For a given module, calculate the power dissipation for each column in the table that contains a current value by multiplying the current value (in Amps) times the voltage for that column. For modules using more than one voltage, add the calculated power values to arrive at the total for the module.

Example 1:

The “Load Requirements” table shows that the IC693CPU352 module draws:

- 910 mA from the +5VDC supply.
- No current from either of the two 12VDC supplies

To calculate power dissipation, multiply 0.910 Amps times 5 Volts. The answer is:

4.55 Watts (of heat dissipated by this module)

Example 2:

The “Load Requirements” table shows that the IC693MDL241 module draws:

- 80 mA from the +5VDC supply
- 125 mA from the +24VDC Isolated supply

To calculate power dissipation from the +5VDC supply:

Multiply 0.08 Amps times 5 Volts to arrive at a value of 0.40 Watts.

To calculate power dissipation from the +24VDC supply:

Multiply 0.125 Amps times 24 Volts to arrive at a value of 3.0 Watts.

Adding the two together, we find the total heat dissipated by this module is 3.4 Watts.

Step 2: Calculation for PLC Power Supplies

A basic rule for Series 90 power supplies is that they are 66% efficient. Another way of stating this is that the power supply dissipates 1 Watt of power in the form of heat for every 2 Watts of power it delivers to the PLC. Therefore, you can calculate the total power requirement for all of the modules in the rack served by a particular power supply using the method in Step 1 above, then divide that figure by 2 to arrive at the power supply dissipation value. You cannot simply use the rating of the power supply (such as 30 Watts) for this calculation because the application may not require the full capacity of the power supply. If you are using the +24VDC output on the power supply’s terminal strip, you should calculate the power drawn, divide the value by 2, and add it to the total for the power supply. Since each Series 90–30 rack has its own power supply, each rack should be calculated on an individual basis.

Step 3: Output Calculations for Discrete Output and Combination Modules

Discrete solid state Output modules and output circuits of Combination I/O modules require two calculations, one for the module’s signal-level circuits, which was already done in Step 1, and one for the output circuits. (This output circuit calculation is not required for the Relay Output modules.) Since the solid state output switching devices in these modules will drop a measurable amount of voltage, their power dissipation can be calculated. Note that the power dissipated by the output circuits comes from a separate power source, so it is not included in the figure used to calculate PLC power supply dissipation in Step 2.

To calculate output circuit power dissipation:

- In the Chapters 7 or 8, find the value for the Output Voltage Drop for your particular Output or Combination I/O module.
- Obtain the required current value for each device (such as a relay, pilot light, solenoid, etc.) connected to an output point on the module and estimate its percent of “on-time.” To obtain the current values, check the device manufacturer’s documentation or an electronics catalog. The percent of on-time can be estimated by someone familiar with how the equipment operates or will operate.
- Multiply the Output Voltage Drop times the current value times the estimated percent of on-time to arrive at average power dissipation for that output.

- Repeat for all outputs on the module. To save time, you could determine if several outputs were similar in current draw and on–time so that you would only have to make their calculation once.
- Repeat these calculations for all Discrete Output modules in the rack.

Discrete Output Module Example:

The IC693MDL340 section of Chapter 7 lists the following for the IC693MDL340 16–Point Discrete 120VAC Output Module:

Output Voltage Drop: *1.5 Volts maximum*

Use that value for all of the calculations for this module.

In this example, two of the Output module’s output points drive solenoids that control the advance and retract travel of a hydraulic cylinder. The solenoid manufacturer’s data sheet shows that each solenoid draws 1.0 Amp. The cylinder advances and retracts once every 60 seconds that the machine is cycling. It takes 6 seconds to advance and 6 seconds to retract.

Since the cylinder takes equal time to advance and retract, both solenoids are on for equal lengths of time: 6 seconds out of every 60 seconds, which is 10% of the time. Therefore, since both solenoids have equal current draws and on–times, our single calculation can be applied to both outputs.

Use the formula *Average Power Dissipation = Voltage Drop x Current Draw (in Amps) x Percent (expressed as a decimal) of on–time:*

$$1.5 \quad \quad \quad \times 1.0 \times 0.10 = 0.15 \text{ Watts per solenoid}$$

Then multiply this result by 2 since we have two identical solenoids:

$$0.15 \text{ Watts} \times 2 \text{ Solenoids} = 0.30 \text{ Watts total for the two solenoids}$$

Also in this example, the other 14 output points on this 16–point module operate pilot lights on an operator’s panel. Each pilot light requires .05 Amps of current. Seven of the pilot lights are on 100% of the time and seven are on an estimated 40%.

For the 7 lights that are on 100% of the time:

$$1.5 \times .05 \times 1.00 = 0.075 \text{ Watts per light}$$

Then multiply this value by 7:

$$0.075 \text{ Watts} \times 7 \text{ lights} = 0.525 \text{ Watts total dissipation for the first 7 lights}$$

For the 7 lights that are on 40% of the time:

$$1.5 \times .05 \times 0.40 = .03 \text{ Watts per light}$$

Then multiply this value by 7:

$$.03 \text{ Watts} \times 7 \text{ lights} = 0.21 \text{ Watts total dissipation for the other 7 lights}$$

Adding up the individual calculations, we get:

$$0.30 + 0.525 + 0.21 = 1.035 \text{ Watts for the module’s total output calculation}$$

Step 4: Input Calculations for Discrete Input or Combination Modules

A Discrete Input or Combination Module requires two calculations, one for the module's signal-level circuits, which was already done in Step 1, and one for the input circuits. Note that the power dissipated by the input circuits comes from a separate power source, so are not included in the figure used to calculate PLC power supply dissipation in Step 2. We will assume that all input circuit power delivered to these modules is eventually dissipated as heat. The procedure is (**note that AC input modules have the additional power factor constant in their formula**):

- Find the value for the Input Current in the "Specifications" table for your Input or Combination I/O module in Chapters 6 or 8.
- **For DC input modules**, multiply the input voltage times the current value times the estimated percent of on-time to arrive at average power dissipation for that DC input.
- **For AC input modules**, multiply the input voltage times the current value times the estimated percent of on-time times 0.10 (power factor constant) to arrive at average power dissipation for that AC input.
- Repeat for all inputs on the module. To save time, you could determine if several inputs were similar in current draw and on-time so that you would only have to make their calculation once.
- Repeat these calculations for all Discrete Input modules in the rack.

Discrete AC Input Module Example:

(**Note the use of the power factor constant in the calculation for this AC input module. The power factor constant is only used for AC input module calculations.**)

The "Specifications" table for the IC693MDL240 16-Point Discrete 120 VAC Input Module in Chapter 6 gives the following information:

Input Current: 12 mA (typical) at rated voltage

Use this value for all of the input calculations for this module.

In this example, eight of the Input Module's points are used for switches that, for normal operation, stay on (closed) 100% of the time. These include the Emergency Stop, Over Temperature, Lube Pressure OK, and similar switches.

Use the formula *Average Power Dissipation = Input Voltage x Input Current (in Amps) x Percent (expressed as a decimal) of on-time x 0.10 power factor constant*:

$$120 \times .012 \times 1.0 \times 0.10 = 0.144 \text{ Watts per input}$$

Then multiply this result by 8:

$$0.144 \text{ Watts} \times 8 \text{ inputs} = 1.152 \text{ Watts total for the 8 inputs}$$

Also in this example, two input points on this 16-point module are for the Control On and Pump Start pushbuttons. Under normal conditions, these pushbuttons are only pressed once per day for about one second – just long enough to start up the control and pump. Therefore, their effect on our power calculation is negligible and we will assume a power dissipation of zero for them:

$$0.0 \text{ Watts total for 2 inputs}$$

For the remaining six inputs of our sixteen point module, it is estimated that they will be on for an average of 20% of the time. So the following calculation is made for these six inputs:

Using the formula of *Average Power Dissipation = Input Voltage x Input Current (in Amps) x Percent (expressed as a decimal) of on-time x 0.10 power factor constant*:

$$120 \times .012 \times 0.20 \times 0.10 = 0.0288 \text{ Watts per input}$$

Then, multiply this result by the number of inputs (6):

$$0.0288 \text{ Watts} \times 6 \text{ inputs} = 0.1728 \text{ Watts total for the 6 inputs}$$

Finally, adding up the individual calculations, we get:

$$1.152 + 0.0 + 0.1728 = 1.3248 \text{ Watts for the module's total input power}$$

Step 5: Final Calculation

Once the individual power dissipations have been calculated, add them all to obtain total PLC heat dissipation. Note that the PLC baseplate, analog input modules, and analog output modules have been ignored in this procedure because their power dissipation values are negligible when compared with the total. Also, since each Series 90–30 rack has its own power supply, each rack should be calculated on an individual basis. The following table summarizes the final calculation:

Series 90–30 Rack Heat Dissipation Calculation Summary		
Step	Description	Value (Watts)
1	Calculate total of dissipation values for all modules in the rack	
2	Divide value obtained in Step 1 by 2 to obtain Power Supply value	
3	Calculate total of all Output modules' output dissipation values	
4	Calculate total of all Input modules' input dissipation values	
5	Add the above four values to obtain the total dissipation of the rack	

Other Information Related to Enclosure Sizing

The “Baseplates” chapter of this manual contains rack dimensions and minimum ventilation clearance distances required around the racks. The “Cables” chapter contains clearance dimensions for cables that mount on the front of modules.

Numbers

32-Point modules

figure, 5-5, 5-6
 installation, 2-21
 installing, 2-19
 TBQC, D-11

A

AC/DC high capacity power supply

illustration of, 4-4
 overvoltage protection devices, 2-39
 specifications, 4-5

AC/DC power supplies

overcurrent protection, 4-22
 status indicators, 4-20
 timing diagram, 4-22

AC/DC standard power supply

ac power source connections, 4-5
 dc power source connections, 4-5
 illustration of, 4-2
 overvoltage protection devices, 2-39, 4-5,
 4-20
 specifications, 4-3

Adapter bracket for 10-slot baseplate, 2-10,

3-22

Analog combo module

%I status information, 12-15
 block diagram, 12-11
 configuration
 with Logicmaster, 90-30, 12-13
 with the hand-held programmer, 12-24
 configuration parameters, 12-12
 current operation, 12-4
 E2 COMMREQ, 12-20
 input ranges, 12-1
 LEDs, 12-7
 location in system, 12-7
 output modes, 12-6
 output ranges, 12-1
 power requirements, 12-7
 ramp mode operation, 12-18
 references used, 12-8
 specifications, 12-2
 status reporting, 12-7
 terminal pin assignments, 12-9
 values from CPU to module for output
 channels, 12-17

voltage operation, 12-4
 wiring diagram, 12-10

Analog current/voltage output module, status reporting, 11-16

Analog I/O modules, 1-1
 Wiring methods, 2-25

Analog input block diagram, typical, 9-5

Analog modules

16-channel current input, 10-27
 16-channel voltage input, 10-9
 2-channel current output, 11-5
 2-channel voltage output, 11-1
 4-channel voltage input, 10-1
 4-channel current input, 10-5
 8-channel current/voltage input, 11-11
 analog combo module, 12-1
 block diagram
 16-channel voltage input, 10-16, 11-30
 16-channel current input, 10-42
 2-channel current output, 11-8
 2-channel voltage output, 11-3
 4-channel current input, 10-7
 4-channel voltage input, 10-3
 8-channel current/voltage output, 11-30
 analog combo module, 12-11
 common mode voltage, 9-5
 CPU interface, 9-6, 10-11, 10-29, 11-13,
 12-7
 differential inputs, 9-4
 equation values, 9-7
 field wiring, 9-11
 hardware description, 9-4
 load requirements, 9-4
 outputs, 9-6
 performance measures, 9-10
 placement of A/D and D/A bits within the
 data tables, 9-8, 10-11, 10-29
 scaling, 9-10
 shielding for analog input modules, 2-26
 stair step effect of output, 9-9

Analog output block diagram, typical, 9-6

Analog terminology, 9-4

Analog terms, definition of, A-1

Appendices

Series 90-30 heat dissipation, F-1
 Terminal Block Quick Connect, D-1

Appendix

analog terms, A-1
 product agency approvals, standards, gen-
 eral specifications, B-1

B

- Backplane
 - Baseplate, 3-14
 - Definition, 3-3
- Backup battery, 4-24
- Baseplate adapter bracket
 - for 10-slot baseplate, 2-10, 3-22
 - installation, 2-11, 3-22
- Baseplate installation, 3-18
 - mounting requirements, model 311/313/323, 3-18
- Baseplate, remote, figure, 3-10
- Baseplate
 - adapter bracket, 2-10, 3-22
 - Common features, 3-1
 - Comparison table, 3-24
 - dimensions for mounting, 10-slot, 3-20
 - dimensions for mounting, 5-slot, 3-18
 - Embedded CPU dimensions, 3-18
 - Expansion and Remote in same system, 3-13
 - expansion dimensions, 3-19
 - Expansion, features, 3-8
 - Grounding, 2-14
 - Modular CPU dimensions, 3-19
 - Mounting, 2-10
 - Mounting dimensions, 3-18
 - mounting in 19" rack, 2-11, 3-23
 - power supply location, 4-2
 - remote 10-slot, 3-11
 - remote 5-slot, 3-10
 - remote dimensions, 3-19
 - Remote, features, 3-10
 - Serial number location, 3-2
 - Sizes, 3-2
 - Terminology, 3-3
 - Types, 3-1
- Baseplates, dimensions for mounting, 10-slot, 3-19
- Battery, Memory backup, 4-24
- Blown fuse status, output modules, 1-2
- Bracket, adapter, 2-10, 3-22

C

- Cable
 - 32-point I/O, C-16, C-19
 - Building 32-point, C-28
 - Extension for I/O module, C-13
 - I/O bus expansion, C-2
 - I/O for 32-point modules, C-15
 - I/O interface, C-23, C-26
- Cable for Series 90-30 installations
 - extension cable for 32 point modules, C-13, C-23, C-31
 - I/O cable for 32 point modules, C-15
 - I/O interface cable for 32 point I/O modules, C-16, C-19, C-26
 - wye cable wiring diagram, earlier version baseplates, C-9
- Cable for Series 90-30 Installations, shield treatment, C-6
- Cables
 - building I/O Bus Expansion, C-2
 - I/O Expansion Bus, 3-12
 - replacing obsolete TBQC, D-3
 - TBQC, D-3
 - TBQC 32-point
 - cross-reference, D-12
 - current rating, D-12
- Calculations for power supply loads, examples, 4-28
- Catalog number location, Baseplate, 3-2
- Catalog numbers, I/O modules
 - IC693ACC300, 6-17
 - IC693ALG220, 10-1
 - IC693ALG221, 10-5
 - IC693ALG222, 10-9
 - IC693ALG223, 10-27
 - IC693ALG390, 11-1
 - IC693ALG391, 11-5
 - IC693ALG392, 11-11
 - IC693ALG442, 12-1
 - IC693DVM300, 7-1
 - IC693MAR590, 8-1
 - IC693MDL230, 6-1
 - IC693MDL231, 6-3
 - IC693MDL240, 6-5
 - IC693MDL241, 6-7
 - IC693MDL310, 7-4
 - IC693MDL330, 7-6
 - IC693MDL340, 7-8
 - IC693MDL390, 7-10
 - IC693MDL632, 6-9
 - IC693MDL634, 6-11
 - IC693MDL645, 6-13
 - IC693MDL646, 6-15
 - IC693MDL653, 6-19
 - IC693MDL654, 6-21
 - IC693MDL655, 6-26
 - IC693MDL730, 7-12

- IC693MDL731, 7-15
 - IC693MDL732, 7-18
 - IC693MDL733, 7-20
 - IC693MDL734, 7-22
 - IC693MDL740, 7-24
 - IC693MDL741, 7-26
 - IC693MDL742, 7-28
 - IC693MDL750, 7-39
 - IC693MDL751, 7-41
 - IC693MDL752, 7-43
 - IC693MDL753, 7-49
 - IC693MDL930, 7-30
 - IC693MDL931, 7-33
 - IC693MDL940, 7-36
 - IC693MDR390, 8-5
 - CIMPLICITY Control programming software, 10-18, 10-31, 11-21, 12-13
 - Clearance requirements, PLC rack, 2-2
 - Color coding, Wires, 2-17
 - Combination I/O modules
 - 120 vac in, relay out, 8-1
 - 24 vdc in, relay out, 8-5
 - analog, 4 inputs/2 outputs, 12-1
 - COMMREQ, E2, 12-20
 - command block, 12-20
 - Configuration parameters, list of
 - analog combo module, 12-12
 - analog current input, 16-channel, 10-33
 - analog current/voltage output, 8-channel, 11-20
 - analog voltage input, 16-channel, 10-20
 - Configuration with HHP
 - 16-channel analog current input, 10-35
 - 16-channel analog voltage input, 10-22
 - 8-channel analog current/voltage output, 11-25
 - analog combo module, 12-24
 - Configuration with Logicmaster 90-30
 - 16-channel analog voltage input, 10-18
 - 16-channel analog current input, 10-31
 - 8-channel analog current/voltage output, 11-21
 - analog combo module, 12-13
 - Conformance to standards, 2-1
 - Connections, to high-density discrete I/O modules, 1-3
 - Connector, serial port, 4-23
 - CPU
 - models, 1-1
 - serial port connector, 4-23
 - CPU baseplate
 - Defined, 3-3
 - Embedded, 3-4
 - Modular, 3-6
 - Types, 3-4
 - Current draw, module, 4-25
 - Current input, analog
 - 16-channel, 10-27
 - 4-channel, 10-5
 - Current output, analog, 2-channel, 11-5
 - Current/voltage Output, analog, 8-channel, 11-11
 - Customer service, telephone number, 2-1
- ## D
- DC high capacity power supply
 - 5 vdc current derating diagram, 4-14, 4-17
 - calculating input power requirements, 4-15, 4-18
 - capacities, 4-13, 4-16
 - illustration of, 4-13
 - output voltages to backplane, 4-21
 - specifications, 4-14, 4-17
 - DC power supply
 - dc power connections, 4-19
 - input power requirements, calculating, 4-8, 4-11, 4-15, 4-18
 - isolated +24 vdc supply connections, 4-6, 4-19
 - overcurrent protection, 4-22
 - specifications, 4-8, 4-11
 - status indicators, 4-20
 - timing diagram, 4-22
 - DC power supply (24/48 VDC), illustration of, 4-7
 - DC power supply (48 VDC), illustration of, 4-10
 - Definition of analog terms, A-1
 - Definition of positive and negative logic for I/O modules, 5-7
 - Diagram, timing, 4-22
 - Differential inputs, 9-4
 - Discrete I/O modules, 1-1
 - DOIO, instruction, 13-4
- ## E
- E2 COMMREQ, 12-20

- E2 COMMREQ example, 12-21
- Embedded CPU baseplates, 3-4
 - Features (figure), 3-5
- Equation values for analog modules, 9-7
- Expansion
 - baseplates, 3-8
 - bus termination, 3-13, C-5
 - extension cables, description of, C-13, C-23, C-31
 - port pin assignments, C-5
- Expansion baseplate
 - defined, 3-3
 - IC693CHS392 figure, 3-9
 - IC693CHS398 figure, 3-8
- Expansion system
 - example, 3-16
 - remote connections, 3-17, C-12
- Extension cables, I/O, C-13, C-23, C-31

F

- Faceplate, I/O, TBQC, D-3
- Fax Link system, 13-9
- Field wiring, to AC/DC power supplies, 2-38
- Field wiring connections
 - IC693ALG220, 10-4
 - IC693ALG221, 10-8
 - IC693ALG222, 10-13
 - IC693ALG223, 10-39
 - IC693ALG390, 11-4
 - IC693ALG392, 11-14
 - IC693ALG442, 12-9
 - IC693MAR590, 8-3
 - IC693MDL230, 6-2
 - IC693MDL231, 6-4
 - IC693MDL240, 6-6
 - IC693MDL241, 6-8
 - IC693MDL310, 7-5
 - IC693MDL330, 7-7
 - IC693MDL340, 7-9
 - IC693MDL390, 7-11
 - IC693MDL632, 6-10
 - IC693MDL634, 6-12
 - IC693MDL645, 6-14
 - IC693MDL646, 6-16
 - IC693MDL653, 6-20
 - IC693MDL654, 6-23
 - IC693MDL655, 6-28
 - IC693MDL730, 7-13

- IC693MDL731, 7-16
- IC693MDL732, 7-19
- IC693MDL733, 7-21
- IC693MDL734, 7-23
- IC693MDL740, 7-25
- IC693MDL741, 7-27
- IC693MDL742, 7-29
- IC693MDL750, 7-40
- IC693MDL751, 7-42
- IC693MDL752, 7-45
- IC693MDL753, 7-51
- IC693MDL930, 7-31
- IC693MDL931, 7-34
- IC693MDL940, 7-37
- IC693MDR390, 8-7
 - to dc input power supply, 4-19
 - to standard ac/dc power supply, 4-5
- Field wiring work sheet
 - IC693MDL654, 6-24
 - IC693MDL655, 6-29
 - IC693MDL752, 7-47
 - IC693MDL753, 7-52

Floating neutral (IT) systems, 2-40

Fuse, table of, 13-6

G

- Ground conductor installation, 2-13
- Ground connections
 - equipment, 2-14
 - programming device, 2-15
 - safety and reference, 2-14
 - shield ground, 2-16
- Grounding procedures, 2-13
 - Baseplate, 2-14
 - Module shield, 2-16
 - System, 2-13
- Grounding procedures, Programmer, 2-15
- Guide to page location for:
 - analog I/O module specifications, 9-1
 - discrete I/O module specifications, 5-1

H

- Hardware, load requirements, 4-25
- Hardware description, analog modules, 9-4
- Heat, dissipation calculations, F-1
- Heat dissipation, calculating, F-1

- Help, from GE Fanuc, 13-9
 - Help, Technical, phone numbers, 13-9
 - High capacity AC/DC power supply
 - illustration of, 4-4
 - overvoltage protection devices, 2-39
 - specifications, 4-5
 - High capacity DC power supply, specifications, 4-14, 4-17
 - High Capacity DC power supply (12 VDC), illustration of, 4-16
 - High Capacity DC power supply (24 VDC), illustration of, 4-13
 - Horner Electric, Inc., 1-4, E-2
 - modules, ordering, 1-4
 - telephone number, 1-4
 - Hotline, technical support, 13-9
 - Hotline, PLC, 2-1
- I**
- I/O bus expansion cable
 - description of, C-2
 - I/O bus terminator plug requirements, C-3
 - maximum cable distance, C-3
 - maximum number in system, C-3
 - I/O Bus Expansion cables
 - Application examples, C-11
 - building, C-2
 - wiring diagrams, C-8
 - I/O bus termination information, C-11
 - I/O cables for 32-point modules, C-15
 - I/O expansion
 - bus termination, 3-13, C-5
 - system connections, C-11
 - I/O Expansion Bus cables, 3-12
 - I/O faceplate, TBQC, D-3
 - I/O interface cables, for 32-point modules, C-16, C-19, C-26
 - I/O module
 - example of, 1-2
 - Figure, standard density, 5-4
 - I/O module specifications, 5-1
 - 12/24 vdc 0.5A positive logic out, 32 pts., 7-49
 - 12/24 vdc negative logic out, 0.5 amp, 16 pts., 7-26
 - 12/24 vdc negative logic out, 0.5 amp, 8 pts., 7-20
 - 12/24 vdc negative logic out, 2 amp, 8 pts., 7-15
 - 12/24 vdc negative logic out, 32 pts., 7-39
 - 12/24 vdc pos. logic escp out, 1 amp, 16 pts., 7-28
 - 12/24 vdc positive logic out, 0.5 amp, 16 pts., 7-24
 - 12/24 vdc positive logic out, 0.5 amp, 8 pts., 7-18
 - 12/24 vdc positive logic out, 2 amp, 8 pts., 7-12
 - 12/24 vdc positive logic out, 32 pts., 7-41
 - 120 vac in, 16 pts., 6-5
 - 120 vac in/relay out, 8 in/8 out, 8-1
 - 120 vac isolated in, 8 pts., 6-1
 - 120 vac out, 0.5 amp, 12 pts., 7-4
 - 120 vac out, 0.5 amp, 16 pts., 7-8
 - 120/240 vac isolated out, 2 amp, 5 pts., 7-10
 - 120/240 vac out, 2 amp, 8 pts., 7-6
 - 125 vdc pos/neg logic in, 8 pts., 6-9
 - 125 vdc pos/neg logic out, 1 amp, 6 pts., 7-22
 - 24 vac or vdc pos/neg logic in, 16 pts., 6-7
 - 24 vdc in/relay out, 8 in/8 out, 8-5
 - 24 vdc pos/neg logic in, 16 pts., 6-13
 - 24 vdc pos/neg logic in, 32 pts., 6-26
 - 24 vdc pos/neg logic in, 8 pts., 6-11
 - 24 vdc pos/neg logic in, FAST, 16 pts., 6-15
 - 24 vdc pos/neg logic,in, FAST, 32 pts., 6-19
 - 240 vac isolated in, 8 pts., 6-3
 - 5/12 vdc (TTL) pos/neg logic in, 32 pts., 6-21
 - 5/24 vdc (TTL) negative logic out, 32 pts., 7-43
 - analog combo module, 12-1
 - analog current in, 16 channel, 10-27
 - analog current in, 4 channel, 10-5
 - analog current out, 2 channel, 11-5
 - analog current/voltage out, 8 channel, 11-11
 - analog voltage in, 16 channel, 10-9
 - analog voltage in, 4 channel, 10-1
 - analog voltage out, 2 channel, 11-1
 - Input simulator, 8/16 pts., 6-17
 - isolated relay n.c. and form c out, 8 amp, 8 pts., 7-33
 - isolated relay n.o., 4 amp, 8 pts., 7-30
 - relay, n.o. out, 2 amp, 16 pts., 7-36
 - I/O Modules
 - 32-point features, 5-5

- 50-pin, 32-point figure, 5-6
- Analog features, 9-2
- Standard density, 5-3
- Analog I/O modules
 - general data, 9-1
 - Figure, 9-3
 - load requirements, 9-3
 - maximum number per system, 9-12
 - user references and current requirements, 9-12
 - user references available per system, 9-12
- I/O modules
 - 32-point figure, 5-5
 - 32-point wiring figure, 2-20
 - blown fuse status for output modules, 1-2
 - circuit status leds, 1-2
 - color code for type, 1-3
 - discrete, 5-1
 - Horner Electric, Inc., 1-4
 - insert with wiring information, 1-2
 - inserting a module, 2-5
 - installing a terminal board, 2-7
 - load requirements, analog modules, 9-4
 - removing a module, 2-6
 - removing a terminal board, 2-8
 - terminal board, 1-3
 - types of, 1-1
 - wiring to modules, 2-18
- I/O system, rack-type, 1-1
- I/O terminal block
 - IC693ACC329, D-6
 - IC693ACC330, D-7
 - IC693ACC331, D-8
 - IC693ACC332, D-9
 - IC693ACC333, D-10
 - IC693ACC377, D-13
- IC693ACC307, terminator, I/O bus, 2-44
- IC693ACC308, baseplate adapter bracket, 2-10, 3-22
- IC693ACC308 Bracket, 19" rack mounting, 2-11, 3-23
- IC693ACC313 Bracket, recessed 19" rack mount, 2-12, 3-23
- IC693ACC329, TBQC, D-6
- IC693ACC330, TBQC, D-7
- IC693ACC331, TBQC, D-8
- IC693ACC332, TBQC, D-9
- IC693ACC333, D-10
- IC693ACC334, TBQC faceplate, D-3
- IC693ACC377, TBQC, D-13
- IC693CBK002, cable kit, D-12
- IC693CBK002/003/004, cable kits for TBQC, C-32
- IC693CBK003, D-12
- IC693CBK004, D-12
- IC693CBL300, Cable, I/O Bus Expansion, C-2
- IC693CBL301, Cable, I/O Bus Expansion, C-2
- IC693CBL302, Cable, I/O Bus Expansion, C-2
- IC693CBL306, Cable, 32-point I/O, C-13
- IC693CBL307, Cable, 32-point I/O, C-13
- IC693CBL308, Cable, 32-point I/O, C-15
- IC693CBL309, Cable, 32-point I/O, C-15
- IC693CBL310, Cable, 32-point I/O, C-16
- IC693CBL312, Cable, I/O Bus Expansion, C-2
- IC693CBL313, Cable, I/O Bus Expansion, C-2
- IC693CBL314, Cable, I/O Bus Expansion, C-2
- IC693CBL315, Cable, 32-point I/O, C-19
- IC693CBL321, Cable, 32-point I/O, C-23
- IC693CBL322, Cable, 32-point I/O, C-23
- IC693CBL323, Cable, 32-point I/O, C-23
- IC693CBL327, Cable, 32-point I/O, C-26
- IC693CBL328, Cable, 32-point I/O, C-26
- IC693CBL329, D-12
 - Data sheet, C-31
- IC693CBL330, D-12
 - Data sheet, C-31
- IC693CBL331, D-12
 - Data sheet, C-31
- IC693CBL332, D-12
 - Data sheet, C-31
- IC693CBL333, D-12
 - Data sheet, C-31
- IC693CBL334, D-12
 - Data sheet, C-31
- IC693CHS392, figure, 3-9

- IC693CHS393
 - figure, 3-11
 - remote baseplate, 3-11
 - IC693CHS398, figure, 3-8
 - IC693CHS399, figure, 3-10
 - IC693CPU311, figure, 3-5
 - IC693CPU313 figure, 3-5
 - IC693CPU323, figure, 3-5
 - IC693DVM300
 - connections, 7-3
 - module drawing, 7-1
 - specifications table, 7-2
 - valve driver module, 7-1
 - IC693PWR321, power supply, 4-2
 - IC693PWR322, power supply, 4-7
 - IC693PWR328, power supply, 4-10
 - IC693PWR330, power supply, 4-4
 - IC693PWR331, power supply, 4-13
 - IC693PWR332, power supply, 4-16
 - Indicator lights
 - relating to I/O terminals, 13-1
 - see LED indicators also, 13-2
 - Input modules
 - 120 vac isolated, 8 pts., 6-1
 - 120 vac, 16 pts., 6-5
 - 125 vdc pos/neg logic, 8 pts., 6-9
 - 24 vac or vdc pos/neg logic, 16 pts., 6-7
 - 24 vdc pos/neg logic, 16 pts., 6-13
 - 24 vdc pos/neg logic, 32 pts., 6-26
 - 24 vdc pos/neg logic, 8 pts., 6-11
 - 24 vdc pos/neg logic, FAST, 16 pts., 6-15
 - 24 vdc pos/neg logic, FAST, 32 pts., 6-19
 - 240 vac isolated, 8 pts., 6-3
 - 5/12 vdc, 32 pts., 6-21
 - analog combo, 12-1
 - analog current, 16 channel, 10-27
 - analog current, 4 channel, 10-5
 - analog voltage, 16 channel, 10-9
 - analog voltage, 4 channel, 10-1
 - input simulator, 8/16 pts., 6-17
 - negative logic, 5-8
 - positive logic, 5-7
 - Input/Output module, combination
 - 120 vac in/relay out, 8/8, 8-1
 - 24 vdc in/relay out, 8/8, 8-5
 - Inspection, new system, 2-1
 - Installation
 - 32-Point modules, 2-21
 - baseplate adapter bracket, 2-10, 3-22
 - baseplate, model 311/313, 3-18
 - baseplate, model 323, 3-19
 - Basic procedure, 2-43
 - grounding procedures, 2-13
 - I/O expansion system, C-11
 - load requirements for analog I/O modules, 9-3
 - load requirements for components, 4-25
 - remote expansion system, 3-17, C-12
 - Installing, I/O Module Term Board, 2-7
 - Instructions for floating neutral (IT) systems, 2-40
 - Internet, GE Fanuc site, 13-9
 - Interposing terminal blocks, 2-19, D-2, D-11
- ## J
- Jumper strap for overvoltage protection devices, 4-6, 4-21
- ## K
- Key, CPU, replacement, 13-7
 - Kits, spare parts, mechanical, 13-7
- ## L
- Layout PLC system, good layout benefits, 2-2
 - Layout, PLC, figure, 2-3
 - Layout, PLC system, guidelines, 2-2
 - LED indicators
 - CPU, 13-3
 - Input modules, 13-2
 - Option modules, 13-3
 - Output modules, 13-2
 - power supplies, 4-20
 - relating to terminal board, 13-1
 - LEDs
 - analog combo, 12-7
 - current input module, 16 ch, 10-27
 - current input module, 4 ch, 10-6
 - current output module, 2 ch, 11-7
 - current/voltage output module, 8 ch, 11-16

- on discrete modules, 1-2
- voltage input module, 16 ch, 10-9
- voltage input module, 4 ch, 10-2
- voltage output module, 2 ch, 11-2

List of fuses, 13-6

Lithium battery, 4-24

Load capacity, power supply, 4-25

Load current limitations

- IC693MAR590, 8-2
- IC693MDL930, 7-32
- IC693MDL931, 7-35
- IC693MDL940, 7-38
- IC693MDR390, 8-6

Load requirements

- analog I/O modules, 9-3, 9-4
- hardware, 4-25
- sample calculations, 4-28
- table of, 4-26, 9-4

Local expansion system, example, point-to-point wiring, C-8

Location, rack, 2-2

Low battery warning, 4-24

M

- Maintenance, preventive, table, 13-8
- Making a 100% shielded cable, C-7
- Mechanical spare parts kits, 13-7
- Model 30 I/O, module types, 1-1
- Model 30 I/O modules, terminal board, 1-3
- Module, fuse list, 13-6
- Module features figure, 2-4
- Module load requirements, table, 4-26
- Module location, Defined, 3-3
- Module retention in slot, 1-2
- Modules, replacing, 13-5
- Mounting, Baseplates, 2-10

N

- Negative logic - input modules, 5-8
- Negative logic - output modules, 5-8

- Number of baseplates per system, system controlled by PC, 1-1

O

- Option modules, personal computer interface card, E-1
- Output module fuses, 13-6
- Output modules
 - 12/24 vdc negative logic, 16 pts., 7-26
 - 12/24 vdc negative logic, 32 pts., 7-39
 - 12/24 vdc negative logic, 8 pts., 7-15, 7-20
 - 12/24 vdc positive logic escp, 16 pts., 7-28
 - 12/24 vdc positive logic, 16 pts., 7-24
 - 12/24 vdc positive logic, 32 pts., 7-41
 - 12/24 vdc positive logic, 8 pts., 7-12, 7-18
 - 12/24 vdc, 0.5A positive logic, 32 pts., 7-49
 - 120 vac, 12 pts., 7-4
 - 120 vac, 8 pts., 7-8
 - 120/240 vac isolated, 5 pts., 7-10
 - 120/240 vac, 8 pts., 7-6
 - 125 vdc positive/negative logic, 6 pts., 7-22
 - 5/24 vdc (TTL) neg logic, 32 pts., 7-43
 - analog combo, 12-1
 - analog current, 2 channel, 11-5
 - analog current/voltage, 8 channel, 11-11
 - analog voltage, 2 channel, 11-1
 - isolated relay n.c. and form c, 8 pts., 7-33
 - isolated relay n.o., 8 pts., 7-30
 - negative logic, 5-8
 - positive logic, 5-7
 - relay n.o., 2 amp, 16 pts., 7-36
- Overvoltage protection devices, 4-5, 4-20
 - jumper strap installation, 2-39

P

- Parts kits, mechanical, spare, 13-7
- PCIF/PCIF2, description, E-1
- Personal Computer Interface, Data sheet, E-1
- PLC customer service, 2-1
- PLC hotline, 2-1
- Positive and negative logic definitions, 5-7
- Positive logic - input modules, 5-7
- Positive logic - output modules, 5-7
- Posts, terminal board, 2-9

Power requirements, analog combo, 12-7

Power Supply, DC input only, 4-7

Power supply

+24 vdc output connections, 2-42

24/48 VDC input, 4-7

48 VDC input, 4-10

ac power source connections, 2-38

AC/DC input, 4-2

Backup battery, location, 4-24

Feature comparison, 4-1

field wiring to DC input supply, 4-19

field wiring to standard AC/DC supply,
2-38, 4-5

high capacity 120/240 VAC or 125 VDC,
4-4

high capacity 24 VDC input, 4-13

isolated +24 vdc supply connections, 4-6,
4-19

load calculation, 4-25

load capacity, 4-25

load ratings, 3-21

location in baseplate, 4-2

mounting orientation, 3-21

serial port connector, location of, 4-23

standard 120/240 VAC or 125 VDC, 4-2

temperature, 3-21

Power supply capacities

dc supply, 4-7, 4-10, 4-13, 4-16

high capacity AC/DC supply, 4-4

standard AC/DC supply, 4-2

Power supply output voltages, 4-21

Power Supply slot, 3-3

Power supply specifications

dc supply, 4-8, 4-11

high capacity ac/dc supply, 4-5

high capacity dc supply, 4-14, 4-17

standard ac/dc supply, 4-3

Power supply, 12 VDC input, illustration of,
4-16

Powering down, Expansion and remote racks,
3-13

Preinstallation check, 2-1

Preventive maintenance, table, 13-8

Product support

customer service, 2-1

technical help, 2-1

Protection devices, overvoltage, 2-39, 4-5,
4-20

Q

Quick connect terminal block, D-2

R

Rack, Definition, 3-3

Rack number, Selection switch, 3-14

RAM memory backup battery, 4-24

Ramp mode

error handling, 12-19

selecting, 12-18

setting, 12-18

References, analog combo, 12-8

Relay module, input/output

120 vac input, n.o. relay output, 8-1

24 vdc input, n.o. relay output, 8-5

Relay module, output

2 amp, n.o., 7-36

4 amp, isolated. n.o., 7-30

8 amp, isolated, n.c. and form c, 7-33

Remote, baseplates, 3-10

Remote baseplate

10-slot, 3-11

Defined, 3-3

IC693CHS399, 3-10

Remote baseplates, Features, 3-10

Remote expansion system

connections, 3-17, C-12

example of using wye cables, C-10

example, point-to-point wiring, applica-
tions requiring less noise immunity,
C-8

wye cable wiring diagram, earlier version
baseplates, C-9

Replacing modules, 13-5

RS-485 compatible serial port, 4-23

S

SER, instruction, 13-4

Serial number

Baseplates, 3-2

locating on modules, 2-4

Serial numbers, recording, 2-1

Serial port connector

on power supply, 4-23

- when functional, 4-23
- Series 90–30, 48 VDC supply, 4-10
- Series 90–30 PLC
 - backplane, 3-14
 - baseplate installation, 3-18
 - recording serial numbers, 2-1
 - visual inspection of new system, 2-1
- Series 90–30 power supply, 12 VDC input, 4-16
- Series 90-30
 - 125 vdc supply, 4-2, 4-4
 - 24/48 VDC supply, 4-7
 - high capacity 24 VDC supply, 4-13
 - high capacity ac/dc supply, 4-4
 - I/O module, example of, 1-2
 - I/O system, 1-1
 - power supplies, 4-2, 4-4
 - standard ac/dc supply, 4-2
- Shield grounding, general information, 2-16
- Shield treatment, cables, C-6
- Shielded cable, making a, C-7
- Slot number, Defined, 3-3
- Smart modules, 1-4
- SNP port connection, 4-23
- Spare parts, kits, 13-7
- Spare parts kits, mechanical, 13-7
- Specifications
 - 12 VDC input supply specs., 4-17
 - 12/24 vdc negative logic 0.5 amp output module, 16 points, 7-26
 - 12/24 vdc negative logic 0.5 amp output module, 8 points, 7-20
 - 12/24 vdc negative logic 2 amp output module, 7-15
 - 12/24 vdc negative logic 32 point output module, 7-39
 - 12/24 vdc positive logic 0.5 amp output module, 16 points, 7-24
 - 12/24 vdc positive logic 0.5 amp output module, 8 points, 7-18
 - 12/24 vdc positive logic 2 amp output module, 7-12
 - 12/24 vdc positive logic 32 point output module, 7-41
 - 12/24 vdc positive logic escp 1 amp output module, 16 points, 7-28
 - 12/24 vdc, 0.5A pos logic 32 point output module, 7-50
 - 120 vac input module, 6-5
 - 120 vac input/relay output module, 8-2
 - 120 vac isolated input module, 6-1
 - 120 vac output, 0.5 amp module, 12 points, 7-4
 - 120 vac output, 0.5 amp module, 16 point, 7-8
 - 120/240 vac Isolated output modules, 7-10
 - 120/240 vac output, 2 amp module, 7-6
 - 125 vdc pos/neg logic 2 amp output module, 7-22
 - 125 vdc pos/neg logic input module, 6-9
 - 24 vac or vdc pos/neg logic input module, 6-7
 - 24 vdc high capacity power supply, 4-14
 - 24 vdc input/relay output module, 8-6
 - 24 vdc pos/neg logic input FAST module, 16 points, 6-15
 - 24 vdc pos/neg logic input module, 6-11, 6-13
 - 24 vdc pos/neg logic, 32 point input module (24-pin connector), 6-27
 - 24 vdc pos/neg logic, FAST 32 point input module, 6-19
 - 24/48 vdc power supply, 4-8
 - 240 vac isolated input module, 6-3
 - 48 vdc power supply, 4-11
 - 5/12 vdc (TTL) pos/neg logic, 32 point input module, 6-22
 - 5/24 vdc (TTL) negative logic 32 point output module, 7-44
 - analog combo module, 12-2
 - analog current input module, 4 channel, 10-6
 - analog current output module, 2 channel, 11-7
 - analog voltage input module, 4 channel, 10-3
 - analog voltage output module, 2 channel, 11-2
 - high capacity ac/dc power supply, 4-5
 - input simulator module, 6-17
 - relay output, 2 amp module, 7-36
 - relay output, 4 amp module, 7-30
 - relay output, n.c. and form C, 8 amp module, 7-33
 - standard ac/dc power supply, 4-3
- Standard AC/DC power supply
 - ac power source connections, 4-5
 - dc power source connections, 4-5
 - illustration of, 4-2
 - overvoltage protection devices, 4-5, 4-20
 - specifications, 4-3
- Status reporting
 - analog combo module, 12-7

analog current/voltage output module,
11-16

T

TBQC. *See* Terminal Block Quick Connect

TBQC selection
for 16-point modules, 2-23
for 32-point modules, 2-22, 2-24

Technical support telephone number, 2-1

Telephone numbers
Customer Service, 2-1
GE Fanuc help, 2-1, 13-9
Horner Electric, 1-4

Terminal assignments
16-ch current input module, 10-39
16-ch voltage input module, 10-13
8-ch current/voltage output module, 11-14
analog combo module, 12-9

Terminal block, selection guide, 2-22

Terminal Block Quick Connect, D-1
32-point cables, D-12
cables, D-3
cables and kits, C-32
for 32-point modules, D-11
I/O face plate, D-3
installation, D-3
terminal blocks, D-2, D-11

Terminal Block Quick Connect, for 16-Point
modules, 2-19

Terminal blocks, interposing, D-2, D-11

Terminal board
connecting to, 2-18
Installing, 2-7
posts, 2-9
Removing, 2-8
With holding screws, 2-9, 7-14, 7-17

Terminal board, I/O, detachable, 1-3

Termination, I/O bus, C-11

Terminator, I/O bus, installing, 2-44

Terminology, analog, 9-4

Terms, analog, definition of, A-1

Third party I/O modules, 1-4

Timing diagram, 4-22

Troubleshooting
features of hardware, 13-1
using software, 13-3

U

Universal terminal board, 1-3

V

Visual inspection of new system, 2-1

Voltage input, analog
16-channel, 10-9
4-channel, 10-1

Voltage output, analog, 2-channel, 11-1

W

Warranty claims, 2-1

Web site, GE Fanuc, 13-9

Weidmuller, 912263 terminal block, 2-19

Wiedemuller terminal block, #912263, 2-22

Wire size, power supply wiring, 2-38

Wiring

Color coding, 2-17
General guidelines, 2-17
I/O modules, 2-18
Power supplies, 2-38
Routing wires, 2-17

Wiring methods, Analog I/O modules, 2-25

Wiring practices, 9-4

Work sheet for field wiring

IC693MDL654, 6-24
IC693MDL655, 6-29
IC693MDL752, 7-47
IC693MDL753, 7-52

WYE cable

wiring diagram for current remote base-
plates, C-10
wiring diagram for earlier version base-
plates, C-9
wiring diagram, remote system, C-10
wiring diagram, remote system (for earlier
version baseplates), C-9