

FUJI SERVO SYSTEM FALDIC-W Series

efesotomasyon.com

FUJI SERVO SYSTEM

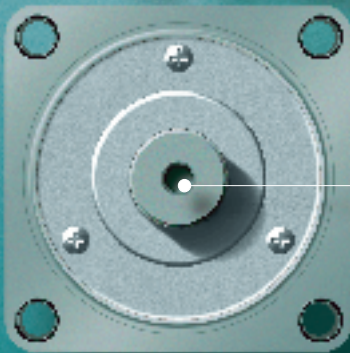

Wide Range

3000 r/min type
0.05 kW-----0.75 kW

2000 r/min type
0.5 kW-----2 kW

1500 r/min type
0.5 kW-----2.9 kW

FALDIC W

SIMPLE & SMART

- 3 Features
- 6 Operation and Indication
- 7 Explanation of Model Codes
- 8 Guide to System Configuration
- Servomotors
 - 10 Specifications [Servomotor]
 - 13 External Dimensions [Servomotor]
- Servo Amplifiers
 - 16 Specifications [Servo Amplifier]
 - 17 Connection Diagram (Reference)
 - 18 External Dimensions [Servo Amplifier]
- 19 Model Code List
- 21 Product Warranty
- 22 Service Network

Simple & Smart

Servo system for evolving machines

FALDIC W

FUJI SERVO SYSTEM

The FALDIC-W – a brand new basic model of the FALDIC series now uses a RoHS compatible environmentally friendly servo system. Additionally, the range of application has increased with the new addition of 1.8 kW and 2.9 kW rated output. The FALDIC series keeps evolving to meet all market requirements.

While pursuing the “advanced functions and sophisticated features required for servo systems”, the FALDIC-W “improves usability” with its easy tuning function etc., and realizes “environmental friendliness” by being RoHS compatible.

The 3-motor lineup with different rated motor speeds meets a "wide range of applications".

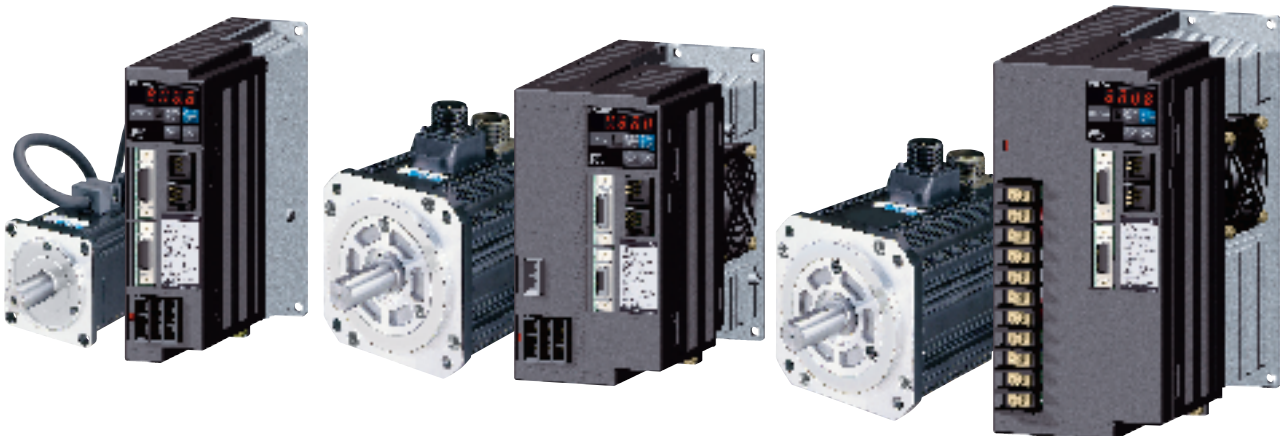

Wide Range

efesotomasyon.com

0.05 kW 0.1 kW 0.2 kW 0.4 kW 0.5 kW 0.75 kW 0.85 kW 1 kW 1.3 kW 1.5 kW 1.8 kW 2 kW 2.9 kW

Low Inertia Series (GYS Motor)
Rated speed: 3000 r/min

Middle Inertia Series (GYG Motor)
Rated speed: 2000 r/min

Middle Inertia Series (GYG Motor)
Rated speed: 1500 r/min

Features



Vibration Suppressing Control Function equipped as standard

Suppresses mechanical vibration to the limit.



Two RS-485 ports as standard

Realizes the integral control of parameters (Maximum 31-axis connection).



Easy tuning

Simple optimum tuning between the machine and servomotor



IP67 (Servomotor)

Water and dust proof servomotor



RoHS compatible

Environmentally friendly servo system



Monitor output function



Side-by-side installation



Globally compatible



Control power back-up function

High-resolution encoder



Servo analysis function



Test operation function



FALDIC



Low Inertia Series (GYS Motor)

Rated speed: **3000 r/min**

Input power supply	Rated output	Motor type (standard type)	Amplifier type
Single-phase 200 to 230V	0.05 kW	GYS500DC2 - T2A	RYC500D3 - VVT2
	0.1 kW	GYS101DC2 - T2A	RYC101D3 - VVT2
	0.2 kW	GYS201DC2 - T2A	RYC201D3 - VVT2
	0.4 kW	GYS401DC2 - T2A	RYC401D3 - VVT2
Single-phase or 3-phase 200 to 230V	0.75 kW	GYS751DC2 - T2A	RYC751D3 - VVT2



3000 r/min type

Middle Inertia Series (GYG Motor)

Rated speed: **2000 r/min**

Input power supply	Rated output	Motor type (standard type)	Amplifier type
Single-phase or 3-phase 200 to 230V	0.5 kW	GYG501CC2 - T2E	RYC501C3 - VVT2
	0.75 kW	GYG751CC2 - T2E	RYC751C3 - VVT2
	1 kW	GYG102CC2 - T2E	RYC102C3 - VVT2
3-phase 200 to 230V	1.5 kW	GYG152CC2 - T2E	RYC152C3 - VVT2
	2 kW	GYG202CC2 - T2E	RYC202C3 - VVT2



2000 r/min type

Middle Inertia Series (GYG Motor)

Rated speed: **1500 r/min**

Input power supply	Rated output	Motor type (standard type)	Amplifier type
Single-phase or 3-phase 200 to 230V	0.5 kW	GYG501BC2 - T2E	RYC501B3 - VVT2
	0.85 kW	GYG851BC2 - T2E	RYC851B3 - VVT2
	1.3 kW	GYG132BC2 - T2E	RYC132B3 - VVT2
3-phase 200 to 230V	1.8 kW	GYG182BC2 - T2G	RYC182B3 - VVT2 NEW
	2.9 kW	GYG292BC2 - T2G	RYC292B3 - VVT2 NEW



1500 r/min type

Other Features



High-resolution encoder

The FALDIC-W is installed with a high-resolution 131072 pulse encoder. Higher resolutions reduce rotation fluctuation and achieve smooth machine motion at low speeds.



Servo analysis function

This is a tool installed in the loader to be equipped with a personal computer, which analyzes the "resonance frequencies" inherent in each machine to make effective use of the "vibration suppressing control function," the "Notch Filter," etc.



Test operation function

Continuous reciprocation is supported in addition to JOG operation in a single direction. You can easily check the performance of the machine by a test operation and the effective torque by rough actual operation before preparing the host controller.

Feature 1



Vibration Suppressing Control Function

Suppresses mechanical vibration to the limit.
Our original vibration suppressing control function (patent pending)

■ A “Vibration Suppressing Control Function” is introduced, which is effective in controlling robot arm end vibration.

Fuji's original “Vibration Suppressing Control Function” is installed as a standard feature. It effectively reduces vibration, especially for low-rigidity units such as a robot arm end, and minimizes machine cycle time.

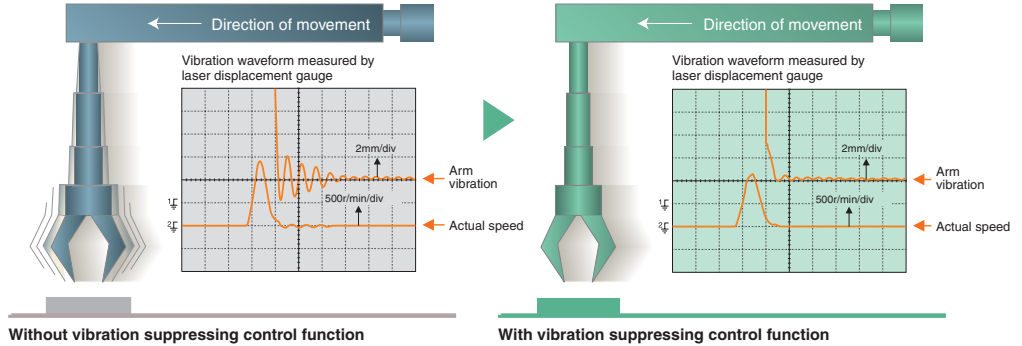

Feature 2



Integral control of parameters

Realizes the integral control of parameters.

■ Two RS-485 ports as standard

RS-485 links the host controller to each servo amplifier, enabling the integral control of the servo amplifier parameters by the host controller.

Image of system configuration

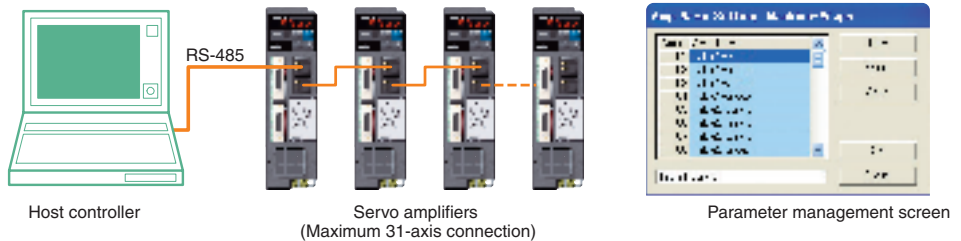

Feature 3



Easy tuning

Simple optimum tuning between the machine and servomotor

The servo amplifier automatically performs auto-tuning on the machine and servomotor to the optimum setting by setting the simple operation pattern in the parameters. Since tuning can be done prior to preparing host devices such as positioning adjustment of the controller, the length of the operation can be decreased.

Feature 4



IP67 (Servomotor)

Water and dust proof servomotor

Since the servomotor complies with IP67*, it can be used in environments where it is exposed to water and dust.

*Excluding the shaft sealing and connector of the GYS motors and the axis through portion of the GYG motors. The GYG motor 1.8 kW and 2.9 kW comply with IP65.

Feature 5



RoHS compatible

Environmentally friendly servo system

The Servo system complies with “The Restriction of Hazardous Substances (RoHS) Directive of the EU”. It is an environmentally friendly servo system, which restricts 6 toxic substances.

<6 Toxic Substances>
Lead, mercury, cadmium, hexavalent chromium, polybrominated biphenyl, polybrominated diphenyl ether



Monitor output function

An analog monitor output function is equipped on the front of the servo amplifier. Connect a special connector to it to observe signals. Two signals can be observed from the return speed, torque command, positional deviation, etc.



Side-by-side installation

Servo amplifiers can be installed side by side, which saves space required to install them in the machine enclosure.



Globally compatible

The FALDIC-W is compatible with “CE marking” and “UL/cUL” standards.

The sequence I/O signals are also sink/source shared.



Control power back-up function

A control power input for the servo amplifier is installed separately from the main power input. Even if the system cuts off the main power supply in emergencies, information on the alarm and encoder can be maintained.

Operation and Indication

Personal computer loader

The loader software for personal computers for the FALDIC-W Series can be downloaded from our website.
<http://www.fujielectric.co.jp/fcs/>



Menu screen

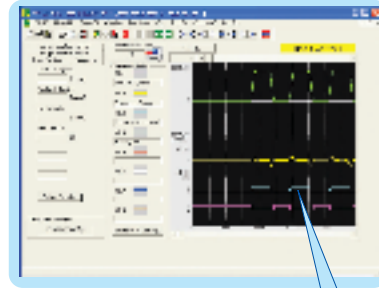

Real-time trace

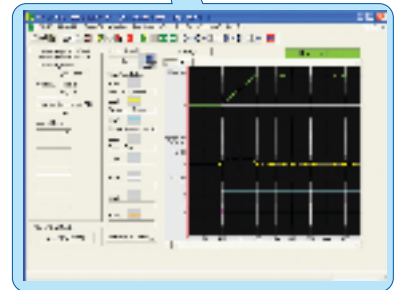

Historical trace

You can set the following with the personal computer loader:

- (1) **Real-time trace** : Speeds and torque curves can be continuously obtained.
- (2) **Historical trace** : Shorter, more detailed curves than real-time trace can be obtained.
- (3) **Monitor 2** : I/O can be checked and alarm history and the system configuration can be monitored.
- (4) **Parameter edit** : Parameters can be edited, transferred, compared, and initialized.
- (5) **Communication setting** : Set the conditions for communication between the servo amplifier and the personal computer.
- (6) **Easy tuning** : The servomotor is automatically reciprocated with easy settings to adjust it to the auto tuning gain suitable for the machine system.
- (7) **Servo analysis** : Inspects the resonance and antiresonance points of the machine system. The effect of the Notch Filter can also be checked.

Keypad

The keypad allows you to use the similar functions as with the personal computer loader.



*The keypad does not display trace but displays a value.

- Mode change key**
- Changes the mode (MODE).
 - Cancels the mode (ESC).

- Shift/Enter key**
- Shifts the data setting digit to the right (SHIFT).
 - Determines the mode or the value (ENT).

- Sub-mode selection key (UP)**
- Increases the value (+1).

- Sub-mode selection key (DOWN)**
- Decreases the value (-1).

Description of modes

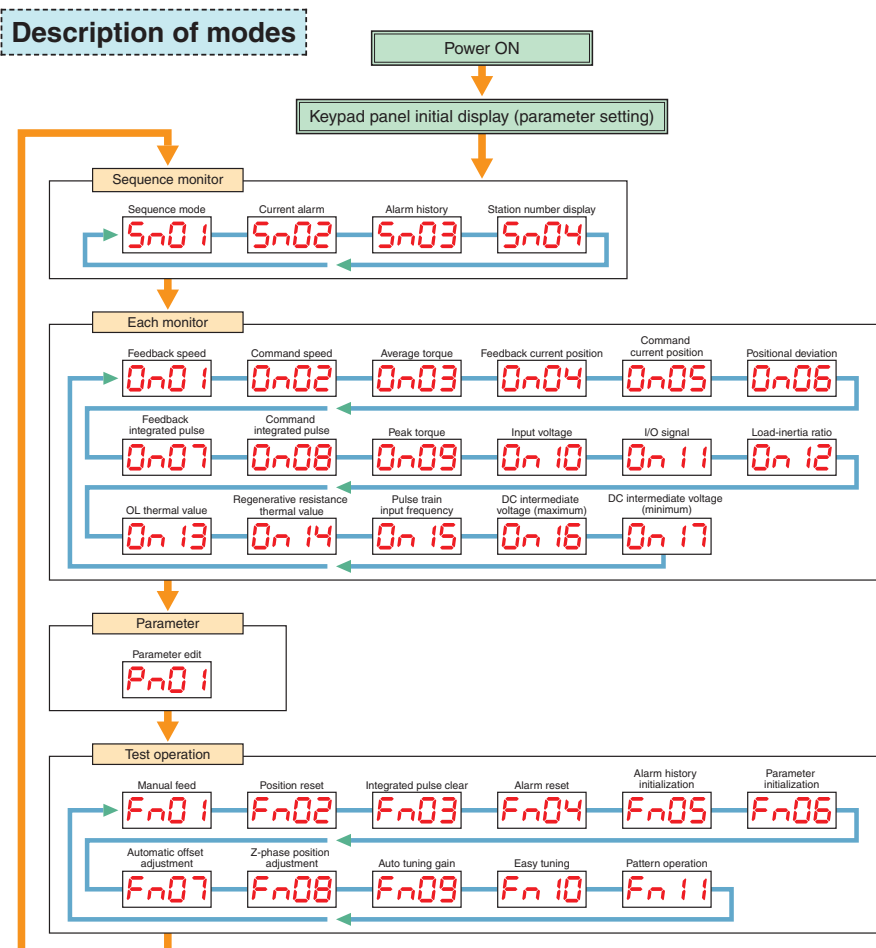

Explanation of Model Codes

Servo amplifier

R Y C 5 0 0 D 3 - V V T 2

Code	[Basic type]
RYC	FALDIC-W Series

Code	[Applicable motor output]
500	50x10 ⁰ =0.05 kW
101	10x10 ¹ =0.1 kW
201	20x10 ¹ =0.2 kW
401	40x10 ¹ =0.4 kW
501	50x10 ¹ =0.5 kW
751	75x10 ¹ =0.75 kW
851	85x10 ¹ =0.85 kW
102	10x10 ² =1 kW
132	13x10 ² =1.3 kW
152	15x10 ² =1.5 kW
182	18x10 ² =1.8 kW
202	20x10 ² =2 kW
292	29x10 ² =2.9 kW

Code	[Series]
D	3000 r/min
C	2000 r/min
B	1500 r/min

Code	[Order of development]

Code	[Input voltage]
2	AC 200 V series

Code	[Encoder]
T	17-bit INC

Code	[Upper interface]
V	DI/DO (speed)

Code	[Major functions]
V	Pulse train/speed control

Servomotor

G Y S 5 0 0 D C 2 - T 2 A - B

Code	[Basic type]
GYS	Low inertia type
GYG	Middle inertia type

Code	[Rated output]
500	50x10 ⁰ =0.05 kW
101	10x10 ¹ =0.1 kW
201	20x10 ¹ =0.2 kW
401	40x10 ¹ =0.4 kW
501	50x10 ¹ =0.5 kW
751	75x10 ¹ =0.75 kW
851	85x10 ¹ =0.85 kW
102	10x10 ² =1 kW
132	13x10 ² =1.3 kW
152	15x10 ² =1.5 kW
182	18x10 ² =1.8 kW
202	20x10 ² =2 kW
292	29x10 ² =2.9 kW

Code	[Rated speed]
D	3000 r/min series
C	2000 r/min series
B	1500 r/min series

Code	[Installation method]
C	Flange mounting

Code	[Order of development]

Code	[Brake]
Omitted	Not provided
B	Provided

Code	[Oil seal / shaft]	Applicable motor	
		GYS	GYG
A	Without an oil seal, straight shaft with a key	☉	△
B	Without an oil seal, straight shaft without a key	○	△
C	Without an oil seal, straight shaft with a key, with tap	△	△
E	With an oil seal, straight shaft with a key	△	☉ ^{*1}
F	With an oil seal, straight shaft without a key	△	△
G	With an oil seal, straight shaft with a key, with tap	△	☉ ^{*2}

*1 : 1.8 kW and 2.9 kW excluded
 *2 : 1.8 kW and 2.9 kW only
 ☉ : Standard item ○ : Near standard items
 △ : Made-to-order item

Code	[Input voltage]
2	AC 200 V series

Code	[Encoder]
T	17-bit INC

Guide to System Configuration

I. Circuit breaker, earth leakage circuit breaker, magnetic contactor

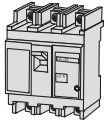

II. AC reactor

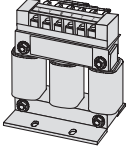

III. Power filter



IV. External regenerative resistor

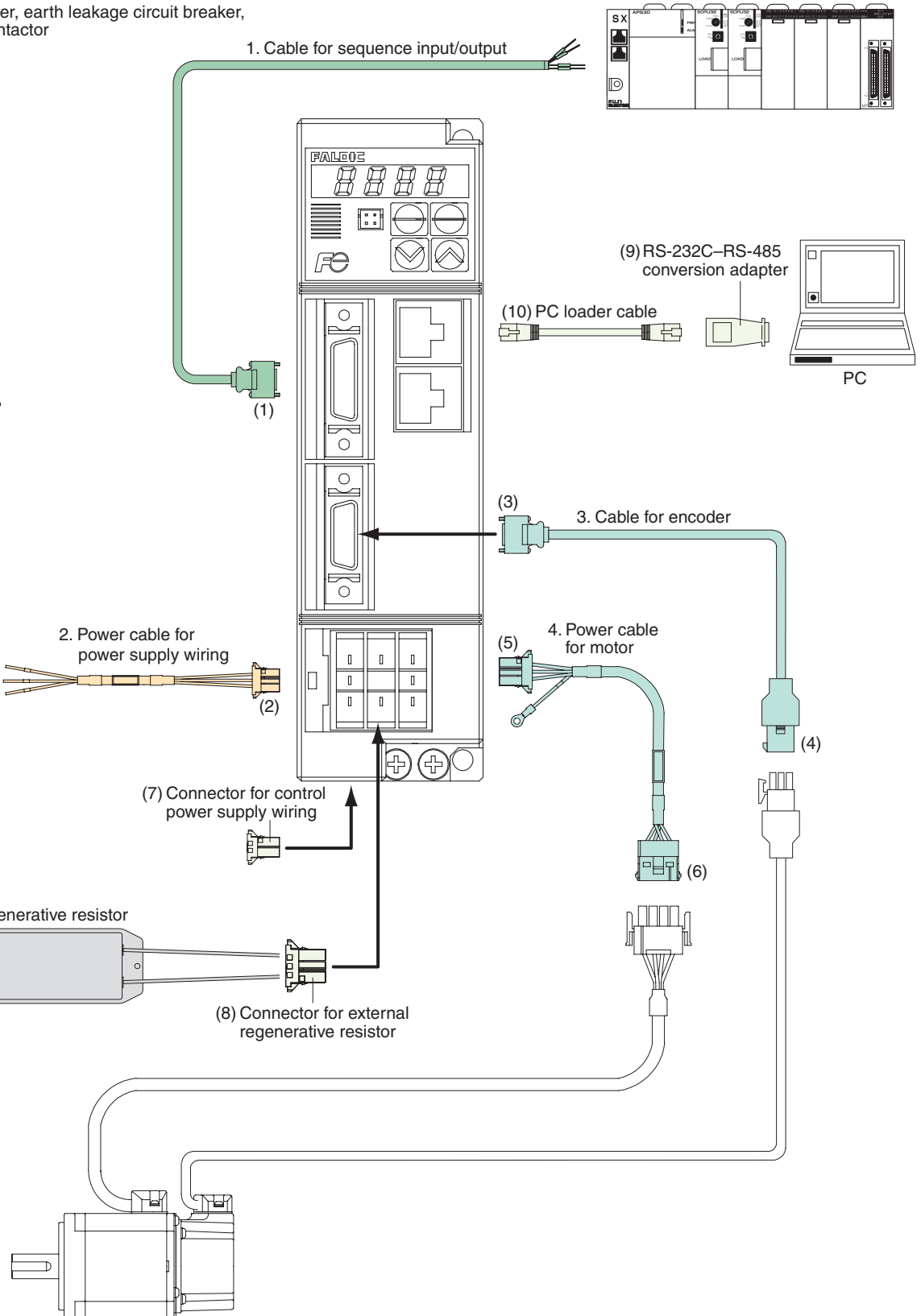
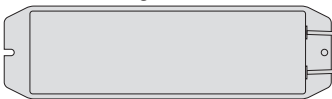

Connector-provided cable correspondence table

Motor series	Rated speed	Brake	Rated output	Between host and amplifier	Between power supply and amplifier	Between amplifier and motor					
				1. Cable for sequence input/output	2. Power cable for power supply wiring	3. Cable for encoder	4. Power cable for motor				
Low inertia	GYS motor	3000 r/min	Not provided	0.05 to 0.75 kW	WSC-S03P03-B (3 m)	WSC-P06P05-D (5 m) WSC-P06P10-D (10 m) WSC-P06P20-D (20 m)	WSC-M04P05-B (5 m) WSC-M04P10-B (10 m) WSC-M04P20-B (20 m)				
			Provided				0.05 to 0.75 kW	WSC-M06P05-B (5 m) WSC-M06P10-B (10 m) WSC-M06P20-B (20 m)			
Middle inertia	GYG motor	2000 r/min	Not provided	WSC-D26P03 (3 m)	*Terminal block wiring	WSC-P06P05-CD (5 m) WSC-P06P10-CD (10 m) WSC-P06P20-CD (20 m)	WSC-M04P05-WD (5 m) (*2) WSC-M04P10-WD (10 m) WSC-M04P20-WD (20 m)				
			Provided				0.5 to 1 kW	- (*1)			
							1.5 to 2 kW	WSC-M04P05-WD (5 m) (*3) WSC-M04P10-WD (10 m) WSC-M04P20-WD (20 m)			
	GYG motor	1500 r/min	Not provided		0.5 to 0.85 kW		*Terminal block wiring	WSC-P06P05-CD (5 m) WSC-P06P10-CD (10 m) WSC-P06P20-CD (20 m)	- (*1)		
			Provided						0.5 to 0.85 kW	WSC-M04P05-WD (5 m) (*2) WSC-M04P10-WD (10 m) WSC-M04P20-WD (20 m)	
									1.3 kW 1.8 kW 2.9 kW	- (*4)	
Provided	0.5 to 0.85 kW	WSC-M04P05-WD (5 m) (*3) WSC-M04P10-WD (10 m) WSC-M04P20-WD (20 m)									
		- (*1)									
		- (*4)									

*1: The customer is requested to make this cable with a specified connector. (Specified connector: WSK-M04P-CA for motors without a brake; WSK-M06P-CA for motors with a brake)
 *2: Use the cable together with the connector for motor power supply wiring WSK-M04P-CA.
 *3: Use the cable together with the connector for motor power supply wiring WSK-M06P-CA. (The customer is requested to make a cable for brakes.)
 *4: The customer is requested to make this cable with a specified connector. (Specified connector: WSK-M09P-CC for both motors without brakes and motors with brakes)

Connector correspondence table

*When the customer makes a cable, use any of the connectors shown in this table.

Motor series	Rated speed	Brake	Rated output	Between host and amplifier	Between power supply and amplifier	Between amplifier and motor						
				(1) Connector for sequence input/output wiring	(2) Connector for power supply wiring	Connector for encoder wiring		Connector for motor power supply wiring				
						(3) Amplifier side	(4) Motor side	(5) Amplifier side	(6) Motor side			
Low inertia	GYS motor	3000 r/min	Not provided	WSC-S03P-B	WSC-S03P-B	WSC-P09P-D	WSC-M03P-B	WSC-M04P				
			Provided					0.05 to 0.75 kW	WSC-M06P			
Middle inertia	GYG motor	2000 r/min	Not provided	WSC-D26P	*Terminal block wiring	WSC-D20P	WSC-M03P-B	WSC-M04P-CA				
			Provided					0.5 to 1 kW	*Terminal block wiring			
								1.5 to 2 kW	WSC-M06P-CA			
	GYG motor	1500 r/min	Not provided		0.5 to 0.85 kW		*Terminal block wiring	WSC-P06P-C	WSC-M03P-B	WSC-M04P-CA		
			Provided							0.5 to 0.85 kW	WSC-M09P-CC	
										1.3 kW 1.8 kW 2.9 kW	WSC-M06P-CA	
Provided	0.5 to 0.85 kW	WSC-M09P-CC										
		WSC-M06P-CA										
		WSC-M09P-CC										

Common options

Name	Type	Description	Remarks
(7) Connector for control power supply wiring	WSK-L02P-D	-	(*4)
(8) Connector for external regenerative resistor	WSK-R03P-B	-	-
For personal computer loader connection	(9) Conversion adapter	NW0H-CNV	RS-232C-RS-485 conversion
	(10) Cable	WSC-PCL	2 m

*4: The 1.3 kW, 1.5 kW, 1.8 kW, 2 kW, and 2.9 kW amplifier do not require this connector because they are connected with a terminal block.

Peripheral devices

Rated speed	Input power supply	Servo amplifier type	Applicable motor output [kW]	I			Surge absorber	II AC reactor	III Power filter	IV External regenerative resistor (*1)
				Circuit breaker	Earth leakage circuit breaker	Magnetic contactor				
3000 r/min	Single-phase 200 to 230 V	RYC500D3-VVT2	0.05	EA32AC/3	EG32AC/3	SC-03	[For control relay] S1-B-0 Specification: 200 Ω(1/2W) +0.1 μF (Okaya Electric Industries)	ACR2-0.4A	RNFTC06-20	WSR-401
		RYC101D3-VVT2	0.1							
		RYC201D3-VVT2	0.2							
		RYC401D3-VVT2	0.4							
		RYC751D3-VVT2	0.75							
		RYC751D3-VVT2	0.75							
2000 r/min	Single-phase 200 to 230 V	RYC501C3-VVT2	0.5	EA32AC/10	EG32AC/10	SC-03	[For electromagnetic contactor] S2-A-0 Specification: 500 Ω(1/2W) +0.2 μF (Okaya Electric Industries)	ACR2-1.5A	RNFTC10-20	WSR-152
		RYC751C3-VVT2	0.75							
		RYC501C3-VVT2	0.5							
		RYC751C3-VVT2	0.75							
		RYC102C3-VVT2	1.0							
		RYC152C3-VVT2	1.5							
1500 r/min	Single-phase 200 to 230 V	RYC501B3-VVT2	0.5	EA33AC/10	EG33AC/10	SC-03	ACR2-1.5A	RNFTC10-20	WSR-152	
		RYC851B3-VVT2	0.85							
		RYC132B3-VVT2	1.3							
		RYC182B3-VVT2	1.8							
		RYC292B3-VVT2	2.9							
		RYC292B3-VVT2	2.9							

*1: To connect the external regenerative resistor WSR-401 or WSR-152 to the amplifier, a connector for external regenerative resistors [type: WSK-R03P-B] is required.

Specifications [Servomotor]

Low inertia series (GYS motor) 3000 r/min

Standard specifications

Motor type	GYS500DC2 -T2 □	GYS101DC2 -T2 □	GYS201DC2 -T2 □	GYS401DC2 -T2 □	GYS751DC2 -T2 □
Rated output [kW]	0.05	0.1	0.2	0.4	0.75
Rated torque [N·m]	0.159	0.318	0.637	1.27	2.39
Max. torque [N·m]	0.478	0.955	1.91	3.82	7.17
Rated speed [r/min]	3000				
Max. speed [r/min]	5000				
Moment of inertia [kg·m ²]	0.0192 x 10 ⁻⁴	0.0371 x 10 ⁻⁴	0.135 x 10 ⁻⁴	0.246 x 10 ⁻⁴	0.853 x 10 ⁻⁴
Rated current [A]	0.85	0.85	1.5	2.7	4.8
Max. current [A]	2.55	2.55	4.5	8.1	14.4
Winding insulation class	Class B				
Operation duty type	Continuous				
Degree of enclosure protection	Fully closed, self-cooled (IP67, excluding the shaft sealing and connectors)				
Terminals (motor)	With 0.3 m flexible leads and connectors				
Terminals (encoder)	With 0.3 m flexible leads and connectors				
Overheat protection	Not provided (The servo amplifier detects temperature.)				
Mounting method	By securing motor flange IMB5 (L51), IMV1 (L52), IMV3 (L53)				
Shaft extension	Straight shaft with a key				
Paint color	N1.5				
Encoder	17-bit serial encoder (Incremental)				
Vibration level	V5 or below				
Installation place, altitude, Environment	For indoor use, 1000 m or below, locations without corrosive or flammable gases, oil mist and dust				
Ambient temperature, humidity	-10 to +40 °C, 90 % RH or below (without condensation)				
Vibration resistance [m/s ²]	49				
Mass [kg]	0.45	0.55	1.2	1.8	3.4

Motor with a brake

Motor type	GYS500DC2 -T2 □-B	GYS101DC2 -T2 □-B	GYS201DC2 -T2 □-B	GYS401DC2 -T2 □-B	GYS751DC2 -T2 □-B
Rated output [kW]	0.05	0.1	0.2	0.4	0.75
Rated torque [N·m]	0.159	0.318	0.637	1.27	2.39
Static friction torque [N·m]	0.34		1.27		2.45
Moment of inertia [kg·m ²]	0.0223 x 10 ⁻⁴	0.0402 x 10 ⁻⁴	0.159 x 10 ⁻⁴	0.270 x 10 ⁻⁴	0.949 x 10 ⁻⁴
Rated DC voltage [V]	DC24 ± 10%				
Attraction time [ms]	35		40		60
Release time [ms]	10		20		25
Brake input [W]	6.1 (at 20°C)		7.3 (at 20°C)		8.5 (at 20°C)
Mass [kg]	0.6	0.7	1.7	2.3	4.2

Torque characteristic diagrams (3000 r/min)

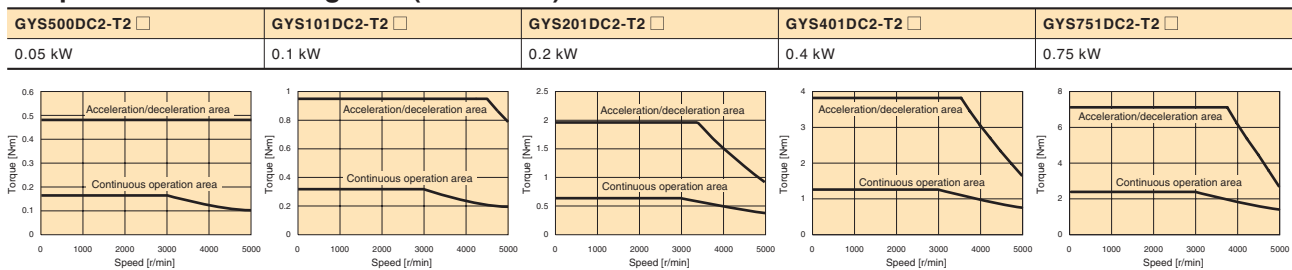

Specifications [Servomotor]

Middle inertia series (GYG motor) 2000 r/min

Standard specifications

Motor type	GYG501CC2 -T2 □	GYG751CC2 -T2 □	GYG102CC2 -T2 □	GYG152CC2 -T2 □	GYG202CC2 -T2 □
Rated output [kW]	0.5	0.75	1.0	1.5	2.0
Rated torque [N·m]	2.39	3.58	4.77	7.16	9.55
Max. torque [N·m]	7.2	10.7	14.3	21.5	28.6
Rated speed [r/min]	2000				
Max. speed [r/min]	3000				
Moment of inertia [kg·m ²]	7.96 x 10 ⁻⁴	11.55 x 10 ⁻⁴	15.14 x 10 ⁻⁴	22.33 x 10 ⁻⁴	29.51 x 10 ⁻⁴
Rated current [A]	3.5	5.2	6.4	10.0	12.3
Max. current [A]	10.5	15.6	19.2	30.0	36.9
Winding insulation class	Class F				
Operation duty type	Continuous				
Degree of enclosure protection	Fully closed, self-cooled (IP67, excluding the shaft sealing)				
Terminals (motor)	Cannon connectors				
Terminals (encoder)	Cannon connectors				
Overheat protection	Not provided (The servo amplifier detects temperature.)				
Mounting method	By securing motor flange IMB5 (L51), IMV1 (L52), IMV3 (L53)				
Shaft extension	Straight shaft with a key, with oil seals				
Paint color	N1.5				
Encoder	17-bit serial encoder (Incremental)				
Vibration level	V10 or below				
Installation place, altitude, Environment	For indoor use, 1000 m or below, locations without corrosive or flammable gases, oil mist and dust				
Ambient temperature, humidity	-10 to +40 °C, 90 % RH or below (without condensation)				
Vibration resistance [m/s ²]	24.5				
Mass [kg]	5.3	6.4	7.5	9.8	12.0

Motor with a brake

Motor type	GYG501CC2 -T2 □-B	GYG751CC2 -T2 □-B	GYG102CC2 -T2 □-B	GYG152CC2 -T2 □-B	GYG202CC2 -T2 □-B
Rated output [kW]	0.5	0.75	1.0	1.5	2.0
Rated torque [N·m]	2.39	3.58	4.77	7.16	9.55
Static friction torque [N·m]	17				
Moment of inertia [kg·m ²]	10 x 10 ⁻⁴	13.6 x 10 ⁻⁴	17.2 x 10 ⁻⁴	24.4 x 10 ⁻⁴	31.6 x 10 ⁻⁴
Rated DC voltage [V]	DC24 ± 10%				
Attraction time [ms]	120				
Release time [ms]	30				
Brake input [W]	14 (at 20°C)				
Mass [kg]	7.5	8.6	9.7	12.0	14.2

Torque characteristic diagrams (2000 r/min)

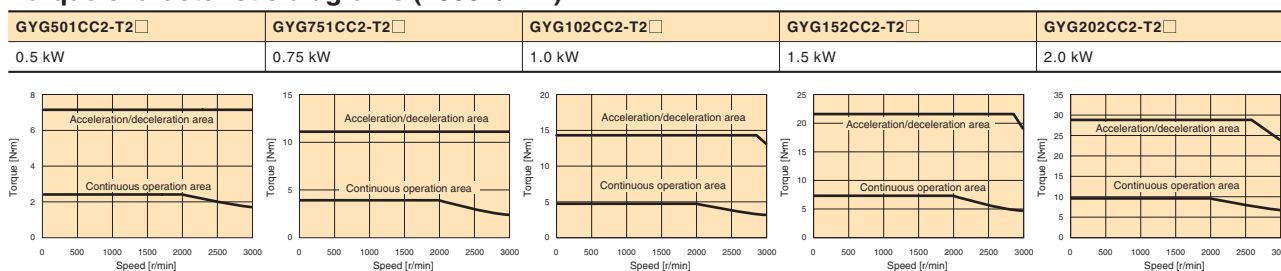

Middle inertia series (GYG motor) 1500 r/min

Standard specifications

Motor type	GYG501BC2 -T2 □	GYG851BC2 -T2 □	GYG132BC2 -T2 □	GYG182BC2 -T2 □	GYG292BC2 -T2 □
Rated output [kW]	0.5	0.85	1.3	1.8	2.9
Rated torque [N·m]	3.18	5.41	8.28	11.5	18.5
Max. torque [N·m]	9.50	16.2	24.8	27.6	44.6
Rated speed [r/min]	1500				
Max. speed [r/min]	3000				
Moment of inertia [kg·m ²]	11.55 x 10 ⁻⁴	15.15 x 10 ⁻⁴	22.33 x 10 ⁻⁴	29.5 x 10 ⁻⁴	43.3 x 10 ⁻⁴
Rated current [A]	4.7	7.3	11.5	17.8	23.6
Max. current [A]	14.1	21.9	34.5	42.7	56.6
Winding insulation class	Class F				
Operation duty type	Continuous				
Degree of enclosure protection	Fully closed, self-cooled (IP67, excluding the shaft sealing)			Fully closed, self-cooled (IP65, excluding the shaft sealing)	
Terminals (motor)	Cannon connectors				
Terminals (encoder)	Cannon connectors				
Overheat protection	Not provided (The servo amplifier detects temperature.)				
Mounting method	By securing motor flange IMB5 (L51), IMV1 (L52), IMV3 (L53)				
Shaft extension	Straight shaft with a key, with oil seals			Straight shaft with a key, with tap, with oil seals	
Paint color	N1.5				
Encoder	17-bit serial encoder (Incremental)				
Vibration level	V10 or below			V15 or below	
Installation place, altitude, Environment	For indoor use, 1000 m or below, locations without corrosive or flammable gases, oil mist and dust				
Ambient temperature, humidity	-10 to +40 °C, 90 % RH or below (without condensation)			0 to +40 °C, 90 % RH or below (without condensation)	
Vibration resistance [m/s ²]	24.5			19.6	
Mass [kg]	6.4	7.5	9.8	16.5	20.5

Motor with a brake

Motor type	GYG501BC2 -T2 □-B	GYG851BC2 -T2 □-B	GYG132BC2 -T2 □-B	GYG182BC2 -T2 □-B	GYG292BC2 -T2 □-B
Rated output [kW]	0.5	0.85	1.3	1.8	2.9
Rated torque [N·m]	3.18	5.41	8.28	11.5	18.6
Static friction torque [N·m]	17			32	
Moment of inertia [kg·m ²]	13.6 x 10 ⁻⁴	17.3 x 10 ⁻⁴	24.5 x 10 ⁻⁴	42.3 x 10 ⁻⁴	56.0 x 10 ⁻⁴
Rated DC voltage [V]	DC24 ± 10%				
Attraction time [ms]	120			170	
Release time [ms]	30			50	
Brake input [W]	14 (at 20°C)			34.7 (at 20°C)	
Mass [kg]	8.6	9.7	12.0	23.5	27.5

Torque characteristic diagrams (1500 r/min)

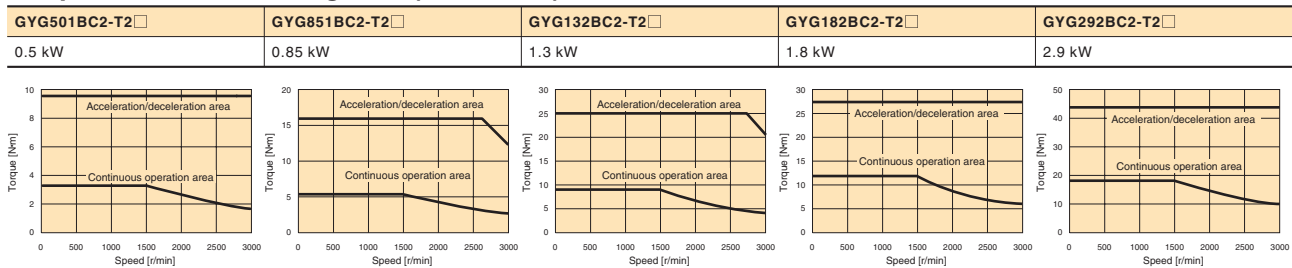

External Dimensions [Servomotor]

Low inertia series (GYS motor) 3000 r/min

Standard type

Rated speed	Rated output	Type	Shaft end shape	Overall length		Mass [kg]
				L	LL	
3000 [r/min]	0.05 kW	GYS500DC2-T2A	Fig. A	103	78	0.45
	0.1 kW	GYS101DC2-T2A	Fig. B	121	96	0.55

(Unit: mm)

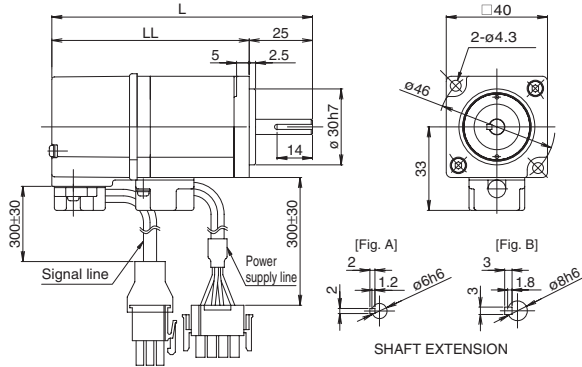

Motor with a brake

Rated speed	Rated output	Type	Shaft end shape	Overall length		Mass [kg]
				L	LL	
3000 [r/min]	0.05 kW	GYS500DC2-T2A-B	Fig. A	137.5	112.5	0.6
	0.1 kW	GYS101DC2-T2A-B	Fig. B	155.5	130.5	0.7

(Unit: mm)

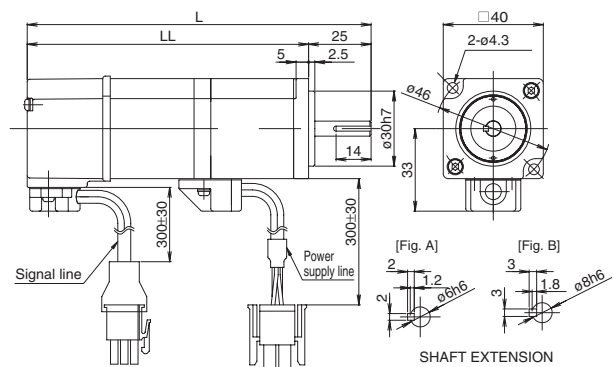

Rated speed	Rated output	Type	Overall length		Mass [kg]
			L	LL	
3000 [r/min]	0.2 kW	GYS201DC2-T2A	126.5	96.5	1.2
	0.4 kW	GYS401DC2-T2A	154.5	124.5	1.8

(Unit: mm)

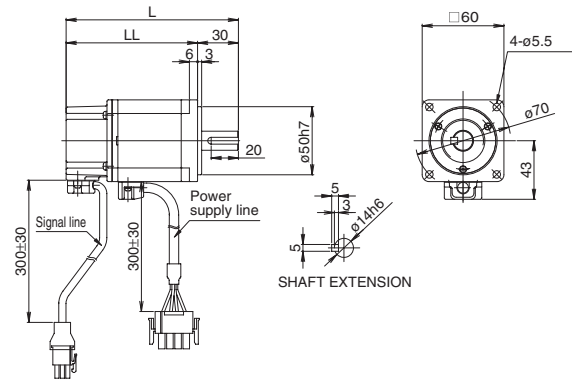

Rated speed	Rated output	Type	Overall length		Mass [kg]
			L	LL	
3000 [r/min]	0.2 kW	GYS201DC2-T2A-B	164.5	134.5	1.7
	0.4 kW	GYS401DC2-T2A-B	192.5	162.5	2.3

(Unit: mm)

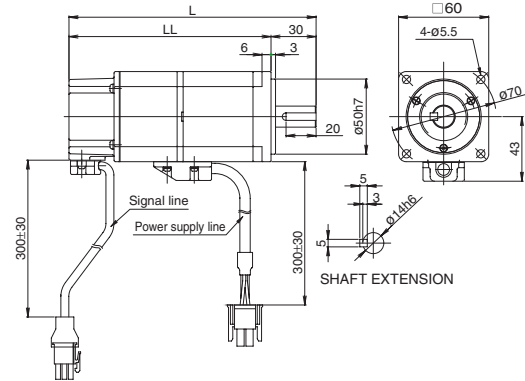

Rated speed	Rated output	Type
3000 [r/min]	0.75 kW	GYS751DC2-T2A

(Unit: mm)

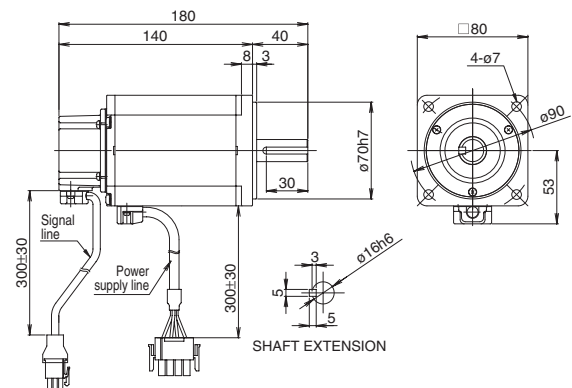

Mass: 3.4 [kg]

Rated speed	Rated output	Type
3000 [r/min]	0.75 kW	GYS751DC2-T2A-B

(Unit: mm)

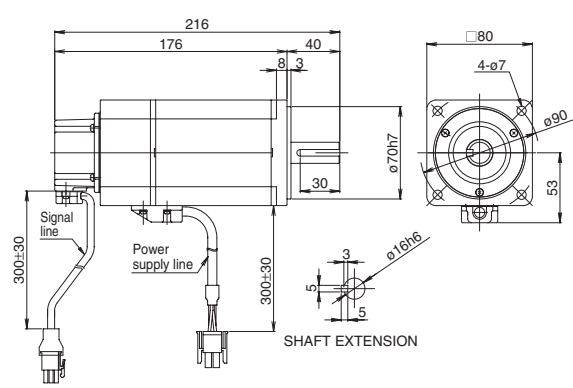

Mass: 4.2 [kg]

External Dimensions [Servomotor]

Middle inertia series (GYG motor) 2000 r/min

Standard type

Rated speed	Rated output	Type	Overall length	Dimension (flange)	Terminal	Mass [kg]
			L	LL	KB1	
2000 [r/min]	0.5 kW	GYG501CC2-T2E	175	120	47.5	5.3
	0.75 kW	GYG751CC2-T2E	187.5	132.5	60	6.4

(Unit: mm)

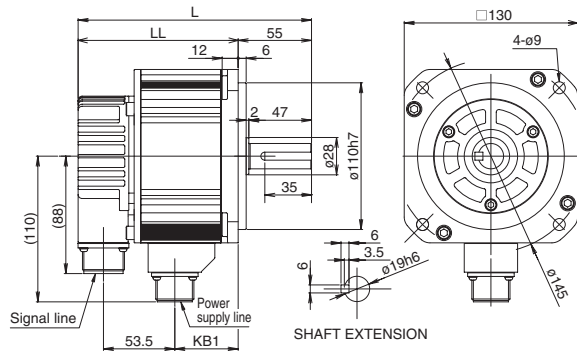

Motor with a brake

Rated speed	Rated output	Type	Overall length	Dimension (flange)	Terminal	Mass [kg]
			L	LL	KB1	
2000 [r/min]	0.5 kW	GYG501CC2-T2E-B	217.5	162.5	52	7.5
	0.75 kW	GYG751CC2-T2E-B	230	175	64.5	8.6

(Unit: mm)

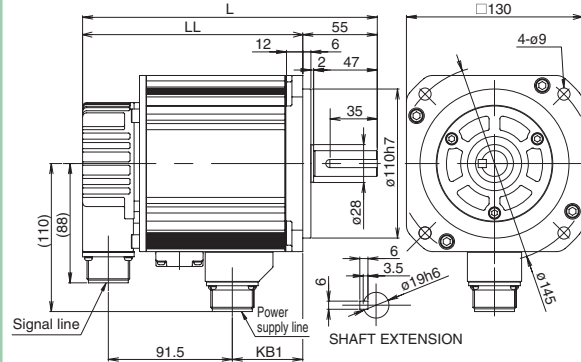

Rated speed	Rated output	Type	Overall length	Dimension (flange)	Terminal	Mass [kg]
			L	LL	KB1	
2000 [r/min]	1 kW	GYG102CC2-T2E	200	145	72.5	7.5
	1.5 kW	GYG152CC2-T2E	225	170	97.5	9.8
	2 kW	GYG202CC2-T2E	250	195	122.5	12

efesotomasyon.com

(Unit: mm)

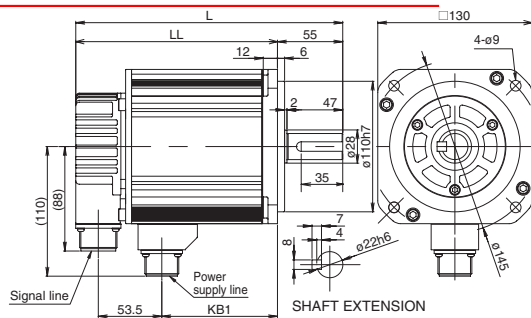

Rated speed	Rated output	Type	Overall length	Dimension (flange)	Terminal	Mass [kg]
			L	LL	KB1	
2000 [r/min]	1 kW	GYG102CC2-T2E-B	242.5	187.5	77	9.7
	1.5 kW	GYG152CC2-T2E-B	267.5	212.5	102	12
	2 kW	GYG202CC2-T2E-B	292.5	237.5	127	14.2

(Unit: mm)

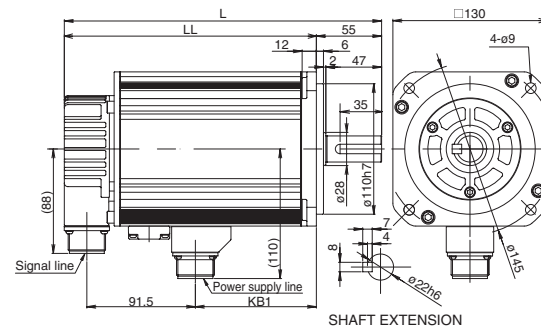

External Dimensions [Servomotor]

efesotomasyon.com

Middle inertia series (GYG motor) 1500 r/min

Standard type

Rated speed	Rated output	Type	Shaft end shape	Overall length		Terminal	Mass [kg]
				L	LL		
1500 [r/min]	0.5 kW	GYG501BC2-T2E	Fig. A	190.5	132.5	60	6.4
	0.85 kW	GYG851BC2-T2E	Fig. A	203	145	72.5	7.5
	1.3 kW	GYG132BC2-T2E	Fig. B	228	170	97.5	9.8

(Unit: mm)

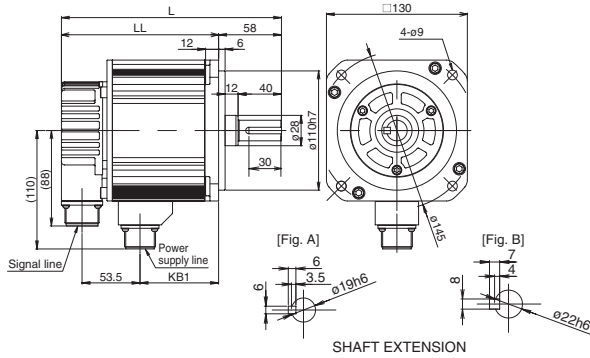

Motor with a brake

Rated speed	Rated output	Type	Shaft end shape	Overall length		Terminal	Mass [kg]
				L	LL		
1500 [r/min]	0.5 kW	GYG501BC2-T2E-B	Fig. A	233	175	64.5	8.6
	0.85 kW	GYG851BC2-T2E-B	Fig. A	245.5	187.5	77	9.7
	1.3 kW	GYG132BC2-T2E-B	Fig. B	270.5	212.5	102	12

(Unit: mm)

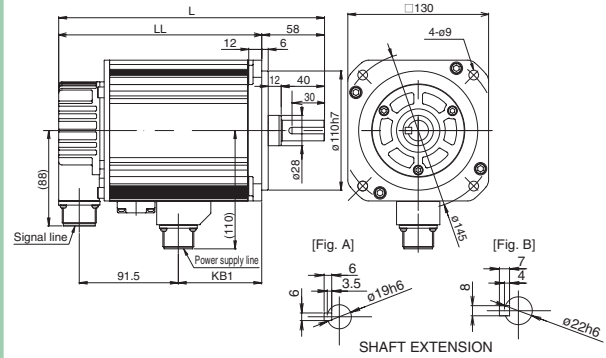

Rated speed	Rated output	Type	Overall length		Terminal	Mass [kg]
			L	LL		
1500 [r/min]	1.8 kW	GYG182BC2-T2G	270	191	85	16.5
	2.9 kW	GYG292BC2-T2G	294	215	109	20.5

(Unit: mm)

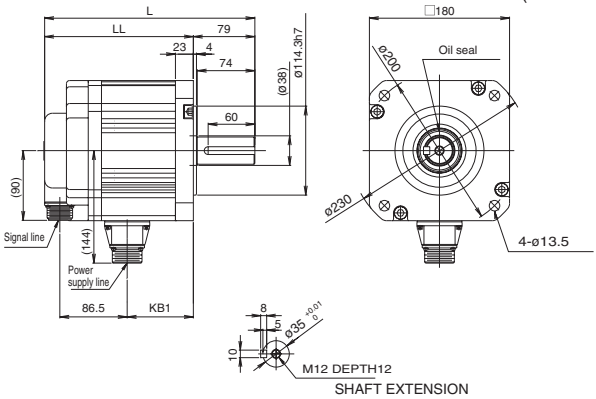

Rated speed	Rated output	Type	Overall length		Terminal	Mass [kg]
			L	LL		
1500 [r/min]	1.8 kW	GYG182BC2-T2G-B	319	240	107	23.5
	2.9 kW	GYG292BC2-T2G-B	343	264	131	27.5

(Unit: mm)

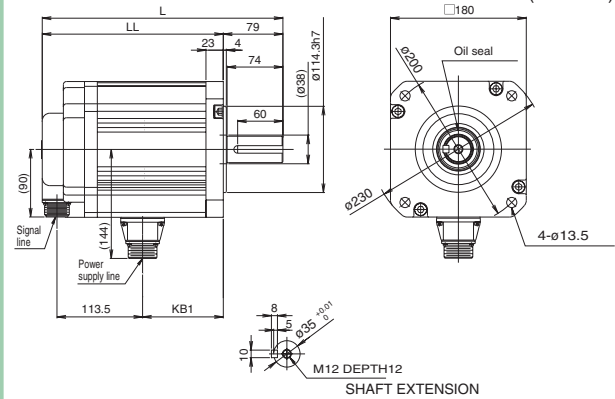

Specifications [Servo Amplifier]

Basic specifications

Applicable motor rated speed		3000 [r/min]					2000 [r/min]					1500 [r/min]					
Applicable motor output		0.05 kW	0.1 kW	0.2 kW	0.4 kW	0.75 kW	0.5 kW	0.75 kW	1 kW	1.5 kW	2 kW	0.5 kW	0.85 kW	1.3 kW	1.8 kW	2.9 kW	
Type RYC□□□	D3-VVT2	500	101	201	401	751											
	C3-VVT2						501	751	102	152	202						
	B3-VVT2											501	851	132	182	292	
Outer frame number		Frame 1					Frame 2	Frame 2			Frame 3		Frame 2	Frame 3	Frame 3A		
Mass [kg]		1.0					1.5			2.5		1.5		2.5	2.6		
Power supply	Main power supply	Phase		Single-phase					Single-phase, 3-phase			3-phase		Single-phase, 3-phase		3-phase	
	Voltage frequency	AC200 to 230 V -15 to +10% (-10 to +10% at Single-phase) 50/60 Hz															
Control power supply	Phase	Single-phase															
	Voltage frequency	AC200 to 230 V -15 to +10% 50/60 Hz															
Control system		IGBT PWM sinusoidal PWM drive															
Feedback		17-bit serial encoder (incremental)															
Functions, input/output signals	Sequence input (CONT1 to 5)		(1) Servo ON, (2) +over-travel, (3) -over-travel, (4) emergency stop, (5) P-action, (6) free run command, (7) anti-resonant frequency selection 1, (8) anti-resonant frequency selection 2, (9) control mode switching, (10) external regenerative resistor overheat, (11) alarm reset These functions can be assigned to sequence inputs CONT1 to CONT5 and used. (*1)														
	Sequence output (OUT1 to 4)		(1) Servo ready, (2) positioning complete, (3) servo alarm detection a-contact, (4) servo alarm detection b-contact, (5) dynamic braking control, (6) over-travel detection, (7) emergency stop detection, (8) deviation zero, (9) speed zero, (10) current limit detection, (11) brake timing These functions can be assigned to sequence outputs OUT1 to OUT4 and used.														
	Encoder signal dividing output	Dividing setting	Pulse output setting 16 to 32768 pulses/rev														
		Signal form	(1) Line driver output A-phase, B-phase, and Z-phase, (2) open collector output Z-phase														
	Monitor output		Analog voltage output for signal measurement (alternating, pulsating) × 2 (1) Speed command, (2) speed return, (3) torque command, (4) positional deviation, (5) positional deviation expansion, (6) pulse command frequency These functions can be assigned to monitor outputs MON1 and MON2 and used, and the output voltage scale and offset can be set by setting parameters.														
	Position control	Max. command pulse frequency	Pulse frequency (max.) command input 1 MHz (differential), 200 kHz (open collector), dividing output 500 kHz (differential)														
		Input pulse signal form	Compatible with two systems: (1) RS-422 line driver signals and (2) open collector signals														
		Input pulse type	Selectable from (1) command pulse/command sign, (2) forward operation/reverse operation pulse, and (3) two 90° phase-different signals														
		Command pulse correction	Position pulse = command pulse × $\frac{\text{command pulse correction } \alpha (1 \text{ to } 32767)}{\text{command pulse correction } \beta (1 \text{ to } 32767)}$ Four types of command pulse correction α can be set, and constant switching operation is available.														
		Position control input	(1) Command pulse correction α selection 1, (2) command pulse correction α selection 2, (3) deviation clear, (4) command pulse disabled These functions can be assigned to sequence inputs CONT1 to CONT5 and used. (*1)														
	Speed control	Speed control range	1:5000														
		Acceleration/deceleration time setting	0 to 10 s / 2000 r/min, acceleration and deceleration times can be set separately, two acceleration times and deceleration times can be set, S-curve acceleration/deceleration is possible.														
		External speed command input	Speed control by analog voltage commands, ±10 V input, the voltage-speed scale and offset can be set by setting parameters.														
		Internal speed setting	Three speeds can be set by setting internal parameters.														
		Speed control input	(1) Multi-speed selection 1, (2) multi-speed selection 2, (3) forward operation, (4) reverse operation, (5) acceleration/deceleration time selection These functions can be assigned to sequence inputs CONT1 to CONT5 and used. (*1)														
Torque control	External torque command input	Torque control by analog voltage commands, ±10 V input, the voltage-torque scale and offset can be set by setting parameters.															
	Torque control input	(1) Forward operation and (2) reverse operation can be assigned to sequence inputs CONT1 to CONT5 and used. (*1)															
Regenerative braking		Regenerative braking to DC intermediate circuit, the regenerative resistor can be externally installed.															
Additional functions		Zero clamp function, vibration suppressing control, notch filter, easy tuning, brake timing output, etc.															
Protection		Overcurrent (OC1, OC2), overspeed (OS), overvoltage (Hv), encoder error (Et), control power error (Ct), memory error (dE), regenerative transistor overheat (H2), encoder communication error (EC), CONT duplication (Cnt), overload (OL), insufficient voltage (LV), regenerative resistor overheat (rH1), excessive deviation (OF), amplifier overheat (AH)															
Working conditions	Installation place		For indoor use at max. altitude of 1,000 m or below. The installation place shall be free from dust, corrosive gas, or direct sunlight. To meet European standards: Pollution degree = 2, overvoltage category = III														
	Temperature/humidity		-10 to 55 °C, 10 to 90 %RH (without condensation)														
	Vibration/shock resistance		4.9 m/s ² [0.5G], 19.6 m/s ² [2G]														
	Standards		Conforming to UL/cUL (UL508c) and CE Mark (low voltage directive EN50178)														

*1: Functions you want to keep ON at all times can be used without wiring (up to four functions can be set by setting parameters as normally ON signals).

Interface specifications

I/O signal specifications

Terminal name	Code	Specification
Pulse train input	CA, *CA CB, *CB PPI	Pulse train form Selectable from (1) command pulse/command code, (2) forward operation pulse/reverse operation pulse, and (3) two 90° phase-different signals. Drive power supply input during open collector input (+24 V DC)
Frequency dividing output	FFA, *FFA FFB, *FFB FFZ, *FFZ FZ, M5	Differential output, two 90° phase-different signal output Set output pulses: 16 to 32768 pulse/rev Differential output 1 pulse/rev Open collector output 1 pulse/rev
Analog input	VREF	Speed control and torque control analog command input ±10 V (input impedance: 20 kΩ)
Power input for sequence signals	P24 M24	+24 V DC for sequence signals is input from outside. 300 mA power is required as an external power supply.
Sequence input signal	CONT1 to CONT5	Each terminal is ON when connected to M24, and OFF when disconnected. +24 V DC/10 mA (per point). The terminals can be assigned to each function by setting parameters. Compatible with sink/source input method.
Sequence output signal	OUT1 to OUT4	ON while connected to the M24 terminal. 30 V DC/50 mA (max.). The terminals can be assigned to each function by setting parameters. Compatible with sink/source output method.
Monitor output 1, monitor output 2	MON1, MON2	Analog voltage output for signal measurement (alternating, pulsating) Selectable from (1) speed command, (2) speed return, (3) torque command, (4) positional deviation, (5) positional deviation expansion, and (6) pulse command frequency.

Communication specifications

Item	Specification
Interface	Two RS-485 ports
Synchronization system	Start-stop synchronization Non-procedure
Transmission system	Four-wire half duplex communication
Baud rate	9600, 19200, 38400 bps
Max. number of axes	31 axes

Connection Diagram (Reference)

efesotomasyon.com

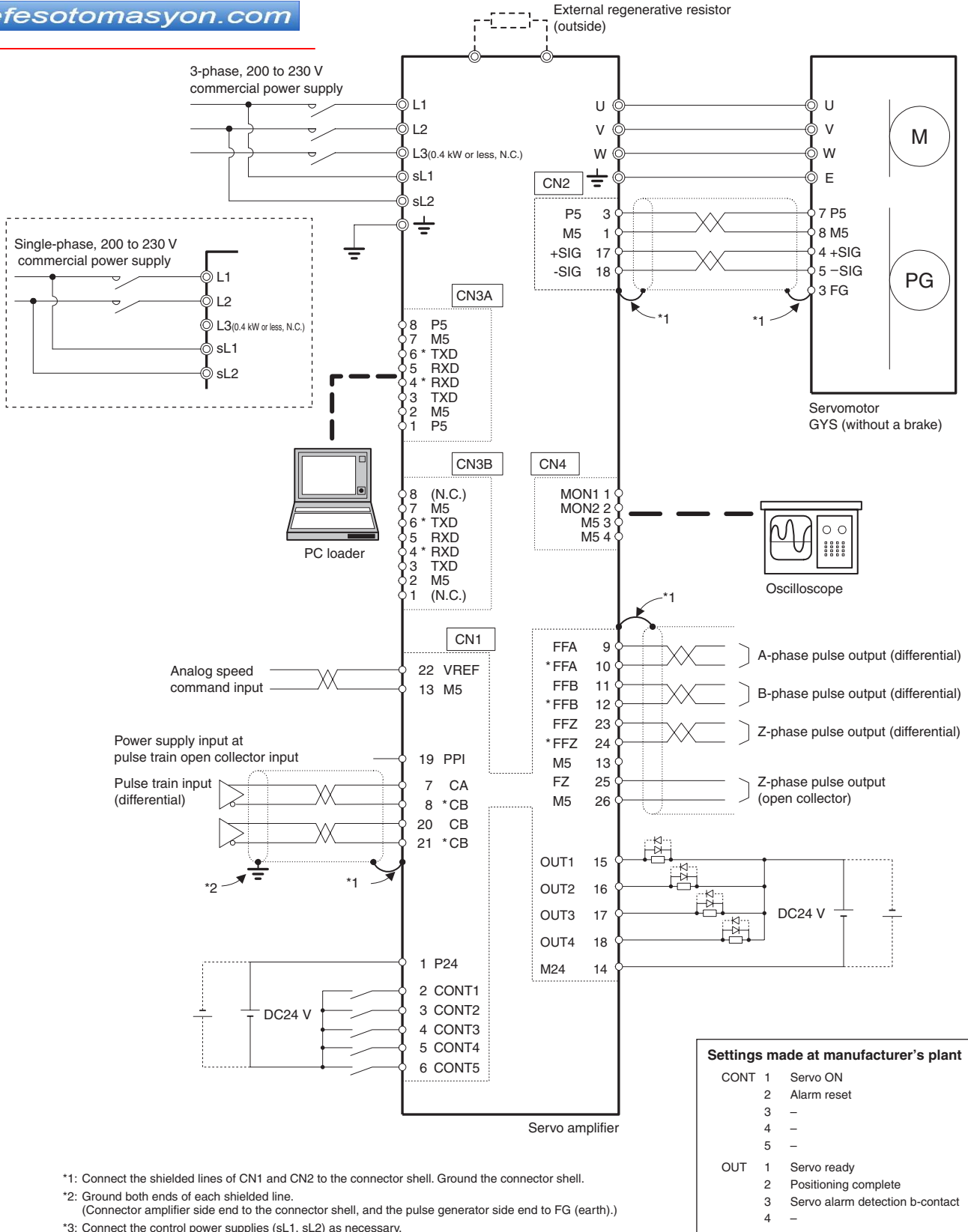

*1: Connect the shielded lines of CN1 and CN2 to the connector shell. Ground the connector shell.
 *2: Ground both ends of each shielded line.
 (Connector amplifier side end to the connector shell, and the pulse generator side end to FG (earth).)
 *3: Connect the control power supplies (sL1, sL2) as necessary.



CAUTION

The diagram shown above is given as a reference for model selection. When actually using the selected servo system, make wiring connections according to the connection diagram and instructions described in the user's manual.

External Dimensions [Servo Amplifier]

efesotomasyon.com

Frame 1

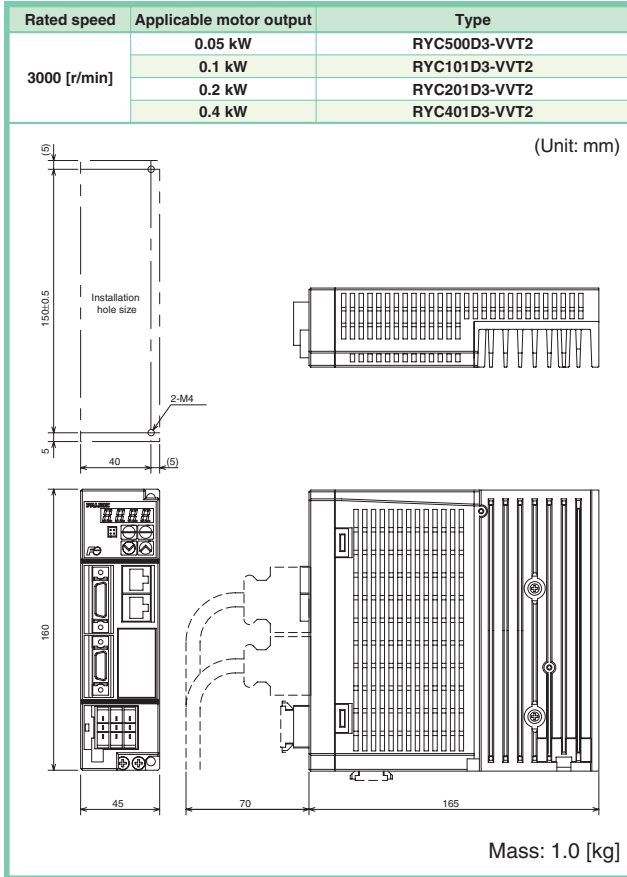

Frame 2

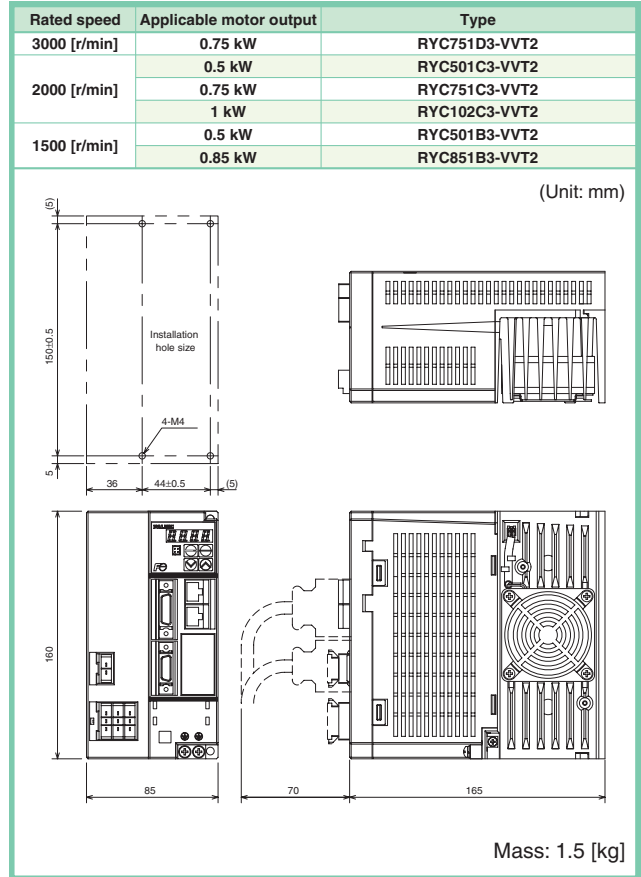

Frame 3

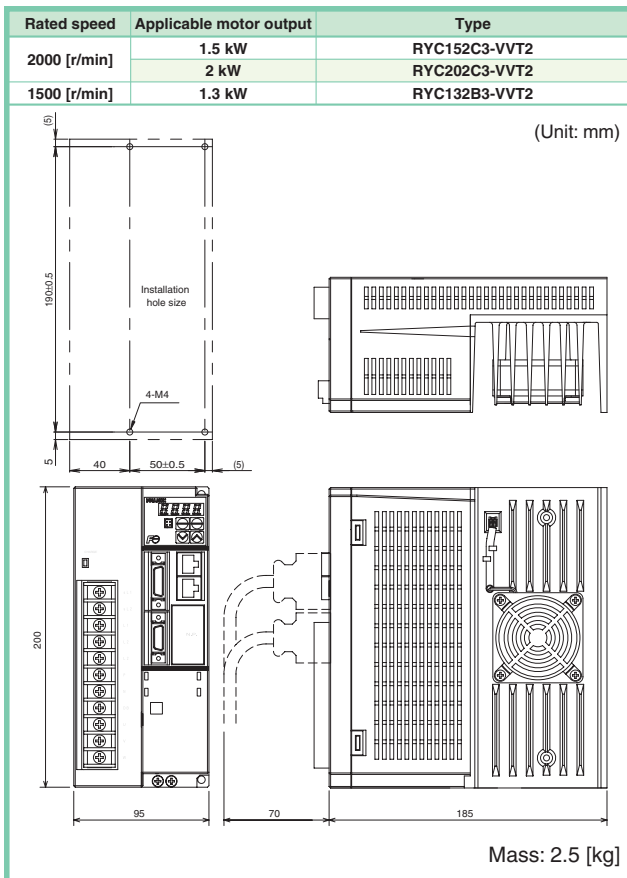

Frame 3A

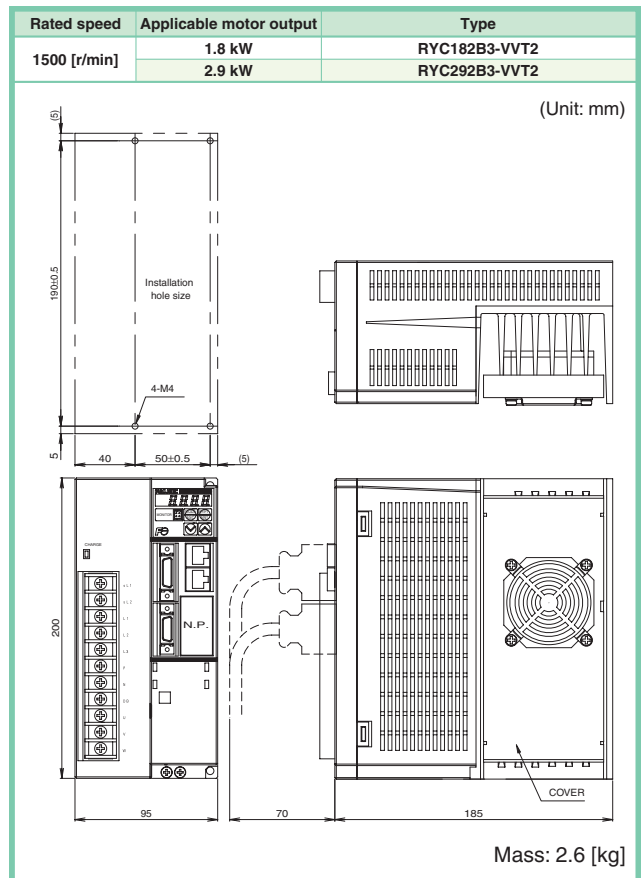

Model Code List

Servomotor

Specification						Type	
Rated speed	Encoder	Winding insulation class (*1)	Oil seal/shaft	Brake	Rated output		
3000 r/min	17-bit INC	IP67	Without an oil seal, with a key (*2)	Without a brake	0.05 kW	GYS500DC2-T2A	
					0.1 kW	GYS101DC2-T2A	
					0.2 kW	GYS201DC2-T2A	
					0.4 kW	GYS401DC2-T2A	
					0.75 kW	GYS751DC2-T2A	
					0.05 kW	GYS500DC2-T2A-B	
			0.1 kW	GYS101DC2-T2A-B			
			0.2 kW	GYS201DC2-T2A-B			
			0.4 kW	GYS401DC2-T2A-B			
			0.75 kW	GYS751DC2-T2A-B			
			Without an oil seal, and a key (*2)	Without a brake	0.05 kW	GYS500DC2-T2B	
					0.1 kW	GYS101DC2-T2B	
		0.2 kW			GYS201DC2-T2B		
		0.4 kW			GYS401DC2-T2B		
		0.75 kW			GYS751DC2-T2B		
		0.05 kW			GYS500DC2-T2B-B		
0.1 kW	GYS101DC2-T2B-B						
0.2 kW	GYS201DC2-T2B-B						
0.4 kW	GYS401DC2-T2B-B						
0.75 kW	GYS751DC2-T2B-B						
2000 r/min	17-bit INC	IP67	With an oil seal and a key (*3)	Without a brake	0.5 kW	GYG501CC2-T2E	
					0.75 kW	GYG751CC2-T2E	
					1 kW	GYG102CC2-T2E	
					1.5 kW	GYG152CC2-T2E	
					2 kW	GYG202CC2-T2E	
					0.5 kW	GYG501CC2-T2E-B	
				0.75 kW	GYG751CC2-T2E-B		
				1 kW	GYG102CC2-T2E-B		
				1.5 kW	GYG152CC2-T2E-B		
				2 kW	GYG202CC2-T2E-B		
				With a brake	Without a brake	0.5 kW	GYG501BC2-T2E
						0.85 kW	GYG851BC2-T2E
1.3 kW	GYG132BC2-T2E						
1.8 kW	GYG182BC2-T2G						
2.9 kW	GYG292BC2-T2G						
0.5 kW	GYG501BC2-T2E-B						
0.85 kW	GYG851BC2-T2E-B						
1.3 kW	GYG132BC2-T2E-B						
1.8 kW	GYG182BC2-T2G-B						
2.9 kW	GYG292BC2-T2G-B						
1500 r/min	17-bit INC	IP67	With an oil seal and a key (*3)	Without a brake	0.5 kW	GYG501BC2-T2E	
					0.85 kW	GYG851BC2-T2E	
					1.3 kW	GYG132BC2-T2E	
					1.8 kW	GYG182BC2-T2G	
		2.9 kW			GYG292BC2-T2G		
		0.5 kW			GYG501BC2-T2E-B		
		0.85 kW		GYG851BC2-T2E-B			
		1.3 kW		GYG132BC2-T2E-B			
		1.8 kW		GYG182BC2-T2G-B			
		2.9 kW		GYG292BC2-T2G-B			
		IP65		Without a brake	0.5 kW	GYG501BC2-T2E	
					0.85 kW	GYG851BC2-T2E	
1.3 kW	GYG132BC2-T2E						
1.8 kW	GYG182BC2-T2G						
IP67	With a brake	0.5 kW	GYG501BC2-T2E-B				
		0.85 kW	GYG851BC2-T2E-B				
		1.3 kW	GYG132BC2-T2E-B				
		1.8 kW	GYG182BC2-T2G-B				
IP65	With a brake	0.5 kW	GYG501BC2-T2E-B				
		0.85 kW	GYG851BC2-T2E-B				
		1.3 kW	GYG132BC2-T2E-B				
		1.8 kW	GYG182BC2-T2G-B				

*1: Excluding the shaft sealing and connectors of the GYS motor, and the shaft sealing of the GYG motor.

*2: Servomotors with an oil seal are made to order.

*3: Servomotors without an oil seal and key are made to order.

Servo amplifier

Specification			Type
Input power supply	Applicable motor	Applicable motor output	
Single-phase 200 to 230 V	Low inertia series (GYS motor) 3000 r/min	For 0.05 kW	RYC500D3-VVT2
		For 0.1 kW	RYC101D3-VVT2
		For 0.2 kW	RYC201D3-VVT2
		For 0.4 kW	RYC401D3-VVT2
		For 0.75 kW	RYC751D3-VVT2
Single-phase or 3-phase 200 to 230 V	Middle inertia series (GYG motor) 2000 r/min	For 0.5 kW	RYC501C3-VVT2
		For 0.75 kW	RYC751C3-VVT2
		For 1 kW	RYC102C3-VVT2
		For 1.5 kW	RYC152C3-VVT2
		For 2 kW	RYC202C3-VVT2
3-phase 200 to 230 V	Middle inertia series (GYG motor) 1500 r/min	For 0.5 kW	RYC501B3-VVT2
		For 0.85 kW	RYC851B3-VVT2
		For 1.3 kW	RYC132B3-VVT2
		For 1.8 kW	RYC182B3-VVT2
		For 2.9 kW	RYC292B3-VVT2

Model Code List

Options

Cables with connectors

Name	Specification		Applicable model (*1)							Type
			(A)	(B)	(C)	(D)	(E)	(F)	(G)	
Cable for sequence input/output (for connection between host controller and amplifier)	3 m	Single-connector	●	●	●	●	●	●	●	WSC-D26P03
Power cable for power supply wiring (for connection between power supply and amplifier)	3 m	Single-connector	●	●	●	●				WSC-S03P03-B
Cable for encoder (for connection between amplifier and motor)	5 m	Double-connector	●	●						WSC-P06P05-D
	10 m									WSC-P06P10-D
	20 m									WSC-P06P20-D
	5 m	Double-connector			●	●	●	●	●	WSC-P06P05-CD
	10 m									WSC-P06P10-CD
	20 m									WSC-P06P20-CD
Power cable for motor (for connection between amplifier and motor)	5 m	Double-connector	●							WSC-M04P05-B
	10 m									WSC-M04P10-B
	20 m									WSC-M04P20-B
	5 m	Double-connector		●						WSC-M06P05-B
	10 m									WSC-M06P10-B
	20 m									WSC-M06P20-B
	5 m	Single-connector			●	●				WSC-M04P05-WD
	10 m									WSC-M04P10-WD
	20 m									WSC-M04P20-WD

*1: For applicable models, see Table 1: Applicable models below.

*2: Use the cable together with the connector for motor power supply wiring WSK-M04P-CA.

*3: Use the cable together with the connector for motor power supply wiring WSK-M06P-CA. (The customer is requested to make a cable for brakes.)

Connectors *When the customer makes a cable, use any of the connectors shown in this table.

Name	Specification		Applicable model (*1)							Type
			(A)	(B)	(C)	(D)	(E)	(F)	(G)	
Connector for sequence input/output wiring	Half pitch connector, soldered type, 26-pin × 1 set		●	●	●	●	●	●	●	WSK-D26P
Connector for power supply wiring	Dynamic connector, X key, 3-pin × 1 set		●	●	●	●				WSK-S03P-B
Connector for encoder wiring	Amplifier side	Half pitch connector, soldered type, 20-pin × 1 set	●	●	●	●	●	●	●	WSK-D20P
	Motor side	MATE-N-LOCK connector, 9-pin × 1 set	●	●						WSK-P09P-D
Connector for motor power supply wiring	Amplifier side	Cannon plug (angle), 6-pin × 1 set			●	●	●	●	●	WSK-P06P-C
		Dynamic connector, Y key, 3-pin × 1 set	●	●	●	●				WSK-M03P-B
	Motor side	MATE-N-LOCK connector, 4-pin × 1 set	●							WSK-M04P
		MATE-N-LOCK connector, 6-pin × 1 set		●						WSK-M06P
		Cannon plug (angle), 4-pin × 1 set			●		●			WSK-M04P-CA
		Cannon plug (angle), 6-pin × 1 set				●		●		WSK-M06P-CA
	Cannon plug (angle), 9-pin × 1 set							●	WSK-M09P-CC	

*1: For applicable models, see Table 1: Applicable models below.

Common options

Name	Specification	Type	
Connector for control power supply wiring	Dynamic connector, X key, 2-pin × 1 set	WSK-L02P-D	
For personal computer loader connection	Conversion adapter	RS-232C-RS-485 conversion	NW0H-CNV
	Cable	Both-end RJ45 connector, straight connection, 2 m	WSC-PCL
External regenerative resistor	0.4 kW or less	Connector for external regenerative resistor: Use it with WSK-R03P-B.	WSR-401
	0.5 kW to 1 kW		WSR-152
	1.3 kW to 2.9 kW		DB11-2
Connector for external regenerative resistor	Common to applicable models A to D (*1), dynamic connector, 3-pin, X key (with insertion error preventive key) × 1 set	WSK-R03P-B	

*1: For applicable models, see Table 1: Applicable models below.

[Table 1: Applicable models]

Motor specification			Motor type	Applicable amplifier type	Applicable model group
Rated speed	Brake	Rated output			
3000 r/min	Without a brake	0.05 kW	GYS500DC2-T2A	RYC500D3-VVT2	(A)
		0.1 kW	GYS101DC2-T2A	RYC101D3-VVT2	
		0.2 kW	GYS201DC2-T2A	RYC201D3-VVT2	
		0.4 kW	GYS401DC2-T2A	RYC401D3-VVT2	
		0.75 kW	GYS751DC2-T2A	RYC751D3-VVT2	
	With a brake	0.05 kW	GYS500DC2-T2A-B	RYC500D3-VVT2	(B)
		0.1 kW	GYS101DC2-T2A-B	RYC101D3-VVT2	
		0.2 kW	GYS201DC2-T2A-B	RYC201D3-VVT2	
		0.4 kW	GYS401DC2-T2A-B	RYC401D3-VVT2	
2000 r/min	Without a brake	0.5 kW	GYG501CC2-T2E	RYC501C3-VVT2	(C)
		0.75 kW	GYG751CC2-T2E	RYC751C3-VVT2	
		1 kW	GYG102CC2-T2E	RYC102C3-VVT2	
		1.5 kW	GYG152CC2-T2E	RYC152C3-VVT2	
		2 kW	GYG202CC2-T2E	RYC202C3-VVT2	

Motor specification			Motor type	Applicable amplifier type	Applicable model group	
Rated speed	Brake	Rated output				
2000 r/min	With a brake	0.5 kW	GYG501BC2-T2E-B	RYC501B3-VVT2	(D)	
		0.75 kW	GYG751BC2-T2E-B	RYC751B3-VVT2		
		1 kW	GYG102BC2-T2E-B	RYC102B3-VVT2		
		1.5 kW	GYG152BC2-T2E-B	RYC152B3-VVT2		
		2 kW	GYG202BC2-T2E-B	RYC202B3-VVT2		
		1500 r/min	Without a brake	0.5 kW		GYG501BC2-T2E
0.85 kW	GYG851BC2-T2E			RYC851B3-VVT2		
1.3 kW	GYG132BC2-T2E			RYC132B3-VVT2		
1.8 kW	GYG182BC2-T2E			RYC182B3-VVT2		
2.9 kW	GYG292BC2-T2E			RYC292B3-VVT2		
With a brake	0.5 kW			GYG501BC2-T2E-B	RYC501B3-VVT2	(D)
	0.85 kW		GYG851BC2-T2E-B	RYC851B3-VVT2		
	1.3 kW		GYG132BC2-T2E-B	RYC132B3-VVT2		
	1.8 kW		GYG182BC2-T2E-B	RYC182B3-VVT2		
	2.9 kW		GYG292BC2-T2E-B	RYC292B3-VVT2		
				0.5 kW	GYG501BC2-T2E	
0.85 kW				GYG851BC2-T2E	RYC851B3-VVT2	
1.3 kW		GYG132BC2-T2E		RYC132B3-VVT2		
1.8 kW		GYG182BC2-T2E		RYC182B3-VVT2		
2.9 kW		GYG292BC2-T2E		RYC292B3-VVT2		
				0.5 kW	GYG501BC2-T2G	RYC501B3-VVT2
	0.85 kW		GYG851BC2-T2G	RYC851B3-VVT2		
	1.3 kW		GYG132BC2-T2G	RYC132B3-VVT2		
	1.8 kW		GYG182BC2-T2G	RYC182B3-VVT2		
	2.9 kW		GYG292BC2-T2G	RYC292B3-VVT2		

Product Warranty

Please take the following items into consideration when placing your order.

When requesting an estimate and placing your orders for the products included in these materials, please be aware that any items such as specifications which are not specifically mentioned in the contract, catalog, specifications or other materials will be as mentioned below.

In addition, the products included in these materials are limited in the use they are put to and the place where they can be used, etc., and may require periodic inspection. Please confirm these points with your sales representative or directly with this company.

Furthermore, regarding purchased products and delivered products, we request that you take adequate consideration of the necessity of rapid receiving inspections and of product management and maintenance even before receiving your products.

1. Warranty Period and Warranty Range

1-1 Warranty period

- (1) The product warranty period is "1 year from the date of purchase" or 24 months from the manufacturing date imprinted on the name place, whichever date is earlier.
- (2) However, in cases where the use environment, conditions of use, use frequency and times used, etc., have an effect on product life, this warranty period may not apply.
- (3) Furthermore, the warranty period for parts restored by Fuji Electric's Service Department is "6 months from the date that repairs are completed."

1-2 Warranty range

- (1) In the event that breakdown occurs during the product's warranty period which is the responsibility of Fuji Electric, Fuji Electric will replace or repair the part of the product that has broken down free of charge at the place where the product was purchased or where it was delivered. However, if the following cases are applicable, the terms of this warranty may not apply.
 - 1) The breakdown was caused by inappropriate conditions, environment, handling or use methods, etc. which are not specified in the catalog, operation manual, specifications or other relevant documents.
 - 2) The breakdown was caused by the product other than the purchased or delivered Fuji's product.
 - 3) The breakdown was caused by the product other than Fuji's product, such as the customer's equipment or software design, etc.
 - 4) Concerning the Fuji's programmable products, the breakdown was caused by a program other than a program supplied by this company, or the results from using such a program.
 - 5) The breakdown was caused by modifications or repairs affected by a party other than Fuji Electric.
 - 6) The breakdown was caused by improper maintenance or replacement using consumables, etc. specified in the operation manual or catalog, etc.
 - 7) The breakdown was caused by a chemical or technical problem that was not foreseen when making practical application of the product at the time it was purchased or delivered.
 - 8) The product was not used in the manner the product was originally intended to be used.
 - 9) The breakdown was caused by a reason which is not this company's responsibility, such as lightning or other disaster.
- (2) Furthermore, the warranty specified herein shall be limited to the purchased or delivered product alone.
- (3) The upper limit for the warranty range shall be as specified in item (1) above and any damages (damage to or loss of machinery or equipment, or lost profits from the same, etc.) consequent to or resulting from breakdown of the purchased or delivered product shall be excluded from coverage by this warranty.

1-3. Trouble diagnosis

As a rule, the customer is requested to carry out a preliminary trouble diagnosis. However, at the customer's request, this company or its service network can perform the trouble diagnosis on a chargeable basis. In this case, the customer is asked to assume the burden for charges levied in accordance with this company's fee schedule.

2. Exclusion of Liability for Loss of Opportunity, etc.

Regardless of whether a breakdown occurs during or after the free of charge warranty period, this company shall not be liable for any loss of opportunity, loss of profits, or damages arising from special circumstances, secondary damages, accident compensation to another company, or damages to products other than this company's products, whether foreseen or not by this company, which this company is not be responsible for causing.

3. Repair Period after Production Stop, Spare Parts Supply Period (Holding Period)

Concerning models (products) which have gone out of production, this company will perform repairs for a period of 7 years after production stop, counting from the month and year when the production stop occurs. In addition, we will continue to supply the spare parts required for repairs for a period of 7 years, counting from the month and year when the production stop occurs. However, if it is estimated that the life cycle of certain electronic and other parts is short and it will be difficult to procure or produce those parts, there may be cases where it is difficult to provide repairs or supply spare parts even within this 7-year period. For details, please confirm at our company's business office or our service office.

4. Transfer Rights

In the case of standard products which do not include settings or adjustments in an application program, the products shall be transported to and transferred to the customer and this company shall not be responsible for local adjustments or trial operation.

5. Service Contents

The cost of purchased and delivered products does not include the cost of dispatching engineers or service costs. Depending on the request, these can be discussed separately.

6. Applicable Scope of Service

Above contents shall be assumed to apply to transactions and use of the country where you purchased the products. Consult the local supplier or Fuji for the detail separately.



Fuji FA Service Centers

- Overseas Service Center
[Service Area: Far East Asia]
5-7, Nihonbashi
Odemma-cho, Chuo-ku, Tokyo, 103-0011, Japan
Phone: (03)5847-8072
- USA Service Center
[Service Area: USA, Canada, Central & South America]
5550 Cerritos Ave. Suite H Cypress, CA. 90630 USA
Phone: (714)220-1879
- CHICAGO Service Station
4825 N. Scott St. Suite 210, Schiller Park, IL 60176 USA
Phone: (847)233-9844
- EC Service Center
[Service Area: Europe, Middle East & Africa]
Goethering 58, 63067
Offenbach/ Main Germany
Phone: (69)669029-0
- South East Asia & Oceania Service Center
[Service Area: SE & S Asia, Oceania]
171 Chin Swee Road, #12-01,
San Centre, Singapore 169877
Phone: (6481)5079
- FUJI-ELECTRIC TECHNOLOGY AND SERVICE (SHENZHEN) CO., LTD
[Service Area: China]
5F, Liming Bldg., No.144,
Zhongxing Rd., Luohu District, Shenzhen
Phone: (0755)8220-2745, 8218-4287

Contracted Service Companies

- USA, Canada, Central & South America Area
USA
OESS CORPORATION(Head Office:NEW JERSEY)
- ① NEW JERSEY
800 Huyler Street Teterboro, NJ 07608, USA
Phone: (201)288-4422
- ② CHICAGO
4825 N Scott Suite 210, Schiller park, IL 60176, USA
Phone: (847)233-9412
- ③ LOS ANGELES
5550 Cerritos Ave. Suite H, Cypress, CA 90630 USA
Phone: (714)220-1879
- ④ SAN JOSE
1440, Koll Circle, Suite 107, San Jose, CA 95112 USA
Phone: (408)437-1582
- ⑤ PORTLAND
7921 SW Cirrus Drive, Beaverton, OR 97008, USA
Phone: (503)520-5044
- Far East Asia Area
- ⑥ KOREA
GAIUS INDUSTRIES CO., LTD.
Cana Bldg., 10-59, Yangjae-Dong, Seocho-Gu, Seoul, 137-887, R.O. KOREA
Phone: (02)3463-0766

- ⑦ TAIWAN
ELTA Electrical Co., Ltd.
4F, No.32. Sec. 3, Cheng TehRoad,
Taipei, Taiwan
Phone: (02)2597-6458
- ⑧ TAIWAN
Full Key International Technology Ltd
12F, No.111-8, HSING TEH RD., SAN-CHUNG CITY, TAIPEI, TAIWAN
Phone: (02)2995-2008
- Europe, Middle East & Africa Area
- ⑨ F.R.GERMANY
OESS GmbH.
Senefelder Strasse 1, 63110 Rodgau,
F.R.GERMANY
Phone: (06106)285-7890
- SE & S Asia, Oceania
- ⑨ SINGAPORE
Fuji Technical Center (S'pore) Pte Ltd.
Block 5000 Ang Mo kio Ave 5 #02-03 Techplacell
SINGAPORE 569870
Phone: (6481)5079
- ⑩ AUSTRALIA
CNC and ROBOTIC AUTOMATED SERVICES
Unit 33/16 Macquarie Place Boronia Victoria 3155,
AUSTRALIA
Phone: (03)9483-8629
- ⑪ INDIA
AUTONUM CONTROLS PVT LTD.
109, Sagar Building, Prabhat Industrial Estate,
W.E. Highway, Befor Check Naka, Dahisar-East,
Mumbai 400 068 INDIA
Phone: (022)28960027



MEMO

SAFETY PRECAUTIONS

- 1 This catalog is intended for use in selecting required servo systems. Before actually using these products, carefully read their instruction manuals and understand their correct usage.
- 2 Products described in this catalog are neither designed nor manufactured for combined use with a system or equipment that will affect human lives.
If you are considering using these products for special purposes, such as atomic energy control, aerospace, medical application, or traffic control, please consult our sales office.
- 3 If you use our product with equipment that is expected to cause serious injury or damage to your property in case of failure, be sure to take appropriate safety measures for the equipment.

The Inverter Value Engineering Center (Suzuka Area) has acquired environment management system ISO14001 and quality management system ISO9001 certifications.



Fuji Electric Systems Co., Ltd.

Gate City Ohsaki, East Tower, 11-2, Osaki 1-chome
Shinagawa-ku, Tokyo 141-0032, Japan
Phone: +81-3-5435-7283 Fax: +81-3-5435-7425

Printed on recycled paper