



**Instruction Manual**  
Supplementary for Braking Unit Built-in type

High Performance, Multifunction Inverter

# ***FRENIC-MEGA***

---

[efesotomasyon.com](http://efesotomasyon.com)

---

## **⚠ CAUTION**

Thank you for purchasing our FRENIC-MEGA series of inverters.

- This product is designed to drive a three-phase induction motor. Read through this instruction manual together with an inverter manual and be familiar with the handling procedure for correct use.
- Improper handling might result in incorrect operation, a short life, or even a failure of this product as well as the motor.
- Deliver this manual to the end user of this product. Keep this manual in a safe place until this product is discarded.
- For how to use an optional device, refer to the instruction and installation manuals for that optional device.

Copyright © 2009 Fuji Electric Systems Co., Ltd.  
All rights reserved.

No part of this publication may be reproduced or copied without prior written permission from Fuji Electric Systems Co., Ltd

All products and company names mentioned in this manual are trademarks or registered trademarks of their respective holders.

The information contained herein is subject to change without prior notice for improvement.

# Preface

This manual is an extraction of pages, which are different from "FRENIC-MEGA Instruction Manual" of standard series, for a supplementary of braking unit installed type (30kW or above). For the pages which are not on this manual, read through "FRENIC-MEGA Instruction Manual" and be familiar with proper handling and operation of this product.

## ■ Safety Precautions

Read through "Safety Precautions" on "FRENIC-MEGA Instruction Manual" and be familiar with proper handling and operation of this product.

## Construction of this manual

Construction of this manual is as follows.

### Chapter1 Before using the inverter

Explanation of an inspection when opening the package, and precautions for carrying and safekeeping the product.

### Chapter2 Mounting and Wiring the inverter

Explanation of operating environment, precautions for mounting and wiring order of motor and power supply.

### Chapter8 Specifications

Specifications such as output ratings and control method, and external dimensions and protection function are mentioned.

## Icons

The following icons are used throughout this manual.



This icon indicates information which, if not heeded, can result in the inverter not operating to full efficiency, as well as information concerning incorrect operations and settings which can result in accidents.



This icon indicates information that can prove handy when performing certain settings or operations.



This icon indicates a reference to more detailed information.

## Table of Contents

Preface .....	i	Chapter8 Specifications	
Safety Precautions .....	i	8.1 Standard Model4	
Construction of this manual .....	i	(Braking unit installed type) .....	8-1
Chapter1 Before using the inverter .....	1-1	8.1.1 Three-phase 200V class series	
1.1 Acceptance Inspection .....	1-1	(HD and LD-mode inverters) .....	8-1
Chapter2 Mounting and Wiring the inverter		8.1.2 Three-phase 400V class series	
2.3.2 Terminal arrangement diagram and		(HD and LD-mode inverters) .....	8-2
screw specifications .....	2-4		
2.3.3 Recommended wire sizes .....	2-6		
2.3.5 Wiring of main circuit terminals			
and grounding terminals .....	2-10		

# Chapter1 BEFORE USING THE INVERTER

## 1.1 Acceptance Inspection

Unpack the package and check the following:

- (1) An inverter and instruction manual (this book) are contained in the package.
  - Accessories:
    - DC Reactor (55kW in LD mode and inverters with 75kW or above)
    - FRENIC-MEGA Instruction Manual
    - Supplementary Instruction Manual for Braking Unit installed type (this manual)
- (2) The inverter has not been damaged during transportation – there should be no dents or parts missing.
- (3) The inverter is the type you ordered. You can check the type and specifications on the main nameplate. (Main and sub nameplates are attached to the inverter and are located as shown on the next page.)

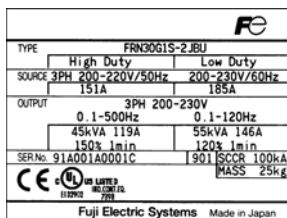

(a) Main Nameplate



(b) Sub Nameplate

☒ 1.1 Nameplates

TYPE: Type of inverter

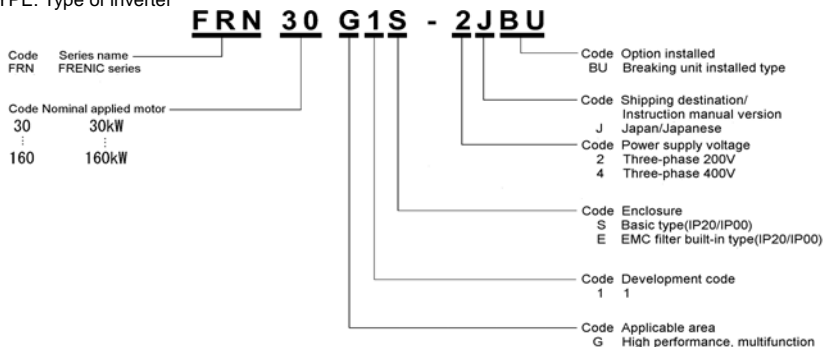

The FRENIC-MEGA is available in two drive modes—High duty (HD) and Low duty (LD) modes. Either mode should be selected to match the load property of your system. Specifications in the HD and LD modes are printed each on the main nameplate. For details, see Chapter 8 “SPECIFICATIONS”.

**High Duty :** HD mode designed for heavy duty load applications. Overload capability: 150% for 1 min, 200% for 3 s. Continuous ratings = Inverter ratings.

**Medium Duty :** MD mode designed for medium duty load applications. Overload capability: 150% 1min. Continuous ratings = One rank higher capacity of inverters.

**Low Duty :** LD mode designed for light duty load applications. Overload capability: 120% for 1min. Continuous ratings = One rank higher capacity of inverters.

**SOURCE :** Number of input phases (three-phase: 3PH), input voltage, input frequency, input current

**OUTPUT :** Number of output phases, rated output voltage, output frequency range, rated output capacity, rated output current, overload capability

**S.C.C. :** Short circuit capacity

**MASS :** Mass of the inverter in kilogram

**SER. No.:** Product number 9 1 A 0 0 1 A 0 0 0 1 C

Production year ——— | ——— Serial number of production lot  
 Last digit of year ——— | ——— Production month  
 1 to 9: January to September  
 X, Y or Z: October, November or December

If you suspect the product is not working properly or if you have any questions about your product, contact your Fuji Electric representative.

## Chapter2 MOUNTING AND WIRING THE INVERTER

For 2.1~2.3.1, see inverter instruction manual.

### 2.3.2 Terminal arrangement diagram and screw specifications

The table and figures given below show the terminal screw sizes, tightening torque and terminal arrangements. Note that the terminal arrangements differ depending on the inverter types. In each of the figures, two grounding terminals “⊕G” are not exclusive to the power supply wiring (primary circuit) or motor wiring (secondary circuit). These terminal arrangements are basic types with a DB terminal.

#### (1) Arrangements of main circuit terminals

Table2.5 Main Circuit Terminal Properties

Power supply voltage	Nominal applied motor (kW)	Inverter type	HD/LD mode	Terminal screw size	Tightening torque (N·m)	Grounding screw size	Tightening torque (N·m)	Refer to:
Three-phase 200V	30	FRN30G1■-2□	HD	M8	13.5	M8	13.5	Figure E
	37		LD					
	45	FRN37G1■-2□	HD	M10	27			Figure F
			LD					
	55	FRN45G1■-2□	HD					
			LD					
75	FRN55G1■-2□	HD						
LD								
Three-phase 400V	30	FRN30G1■-4□	HD	M8	13.5	M8	13.5	Figure E
	37		LD					
	45	FRN37G1■-4□	HD					
			LD					
	55	FRN45G1■-4□	HD					
			LD					
	75	FRN55G1■-4□	HD					
	LD							
	90	FRN75G1■-4□	HD	M10	27	Figure F		
	110	FRN90G1■-4□	MD/LD					
			HD					
	132	FRN110G1■-4□	MD/LD					
HD								
160	FRN132G1■-4□	MD/LD	M12	48	M10	27	Figure G	
		HD						
200	FRN160G1■-4□	MD/LD						
		HD						

**Note:** A box (■) in the above table replaces S or E depending on the enclosure.

A box (□) in the above table replaces T or J depending on the shipping destination.

Terminal R0, T0: Screw size M3.5, Tightening torque 1. 2N·m (common to all inverter types)

Terminal R1, T1: Screw size M3.5, Tightening torque 1. 2N·m (for 200V class series with 37kW or above and for 400V class series with 75kW or above)

Fig. E

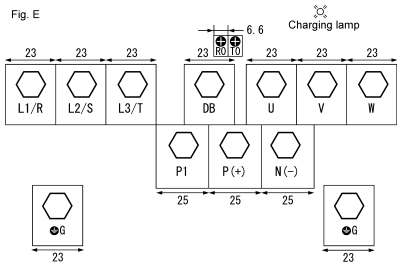

Fig. F

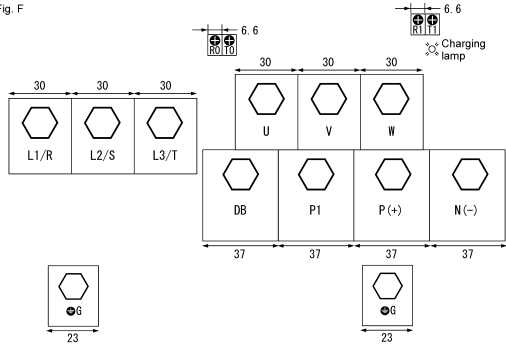
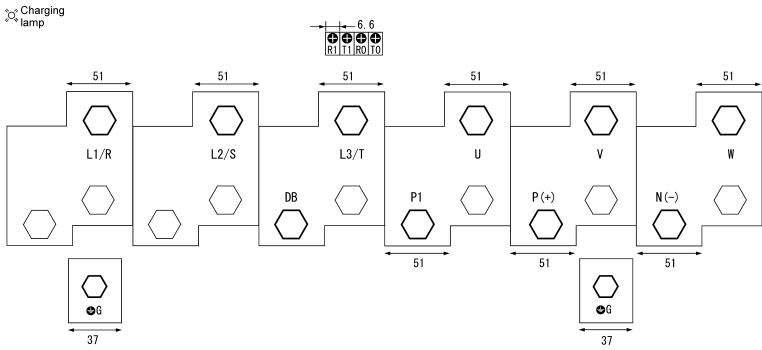

Fig. G



2.3.3 Recommended wire sizes

Table 2.6 lists the recommended wire sizes. Use crimp terminals covered with an insulation sheath or with an insulation tube. The recommended wire sizes for the main circuits are examples of using a single HIV wire (JIS C3317)(for 75°C) at a surrounding temperature of 50°C.

Table2.6 Recommended Wire Sizes

Terminals common to all inverters	Recommended wire size(mm <sup>2</sup> )
Control circuit terminals	0.75*1
Auxiliary power input terminals for the control circuit R0 and T0	2.0
Auxiliary power input terminals for the fans R1 and T1.	2.0 (200V class series with 37kW or above and 400V class series with 75kW or above)

\*1 Using wires exceeding the recommended sizes may lift the front cover depending upon the number of wires used, impeding keypad normal operation.

Power supply voltage	Nominal applied motor (kW)	Inverter type	HD/LD mode	Recommended wire size (mm <sup>2</sup> )					
				Main circuit					Braking resistor [P(+), DB]
				Main circuit power input (L1/R,L2/S,L3/T)		Grounding [G]	Inverter output [U, V, W]	DCR [P1, P(+)]	
w/DCR	w/o DCR								
Three-phase 200V	30	FRN30G1■-2□	HD	38	60	14	38	2	
	37	FRN37G1■-2□	LD						60
	45		HD	60	100	60	100		
	55	LD	100					150*4	100
	75	FRN55G1■-2□		HD	150*4	-	150*4		
			LD						
Three-phase 400V	30	FRN30G1■-4□	HD	14	22	8	14	2	
	37	FRN37G1■-4□	LD						22
	45		HD	22	14	38	38		
	55	LD	38					60	60
	75	FRN55G1■-4□		HD	38	60	100		
	90	LD	60	100				100	100
	110	FRN90G1■-4□			HD	100	-		
	132	LD	150	38	200			250	
	160	FRN132G1■-4□				MD	150		200
	200	FRN160G1■-4□	HD	150	200	250		14	
			LD						
			MD						

\*4 When using 150mm<sup>2</sup> wires for main circuit terminals, use CB150-10 crimp terminals designed for low voltage appliances in JEM1399.

For 2.3.4, see instruction manual of an inverter.

### 2.3.5 Wiring of main circuit terminals and grounding terminals

#### Connection diagram

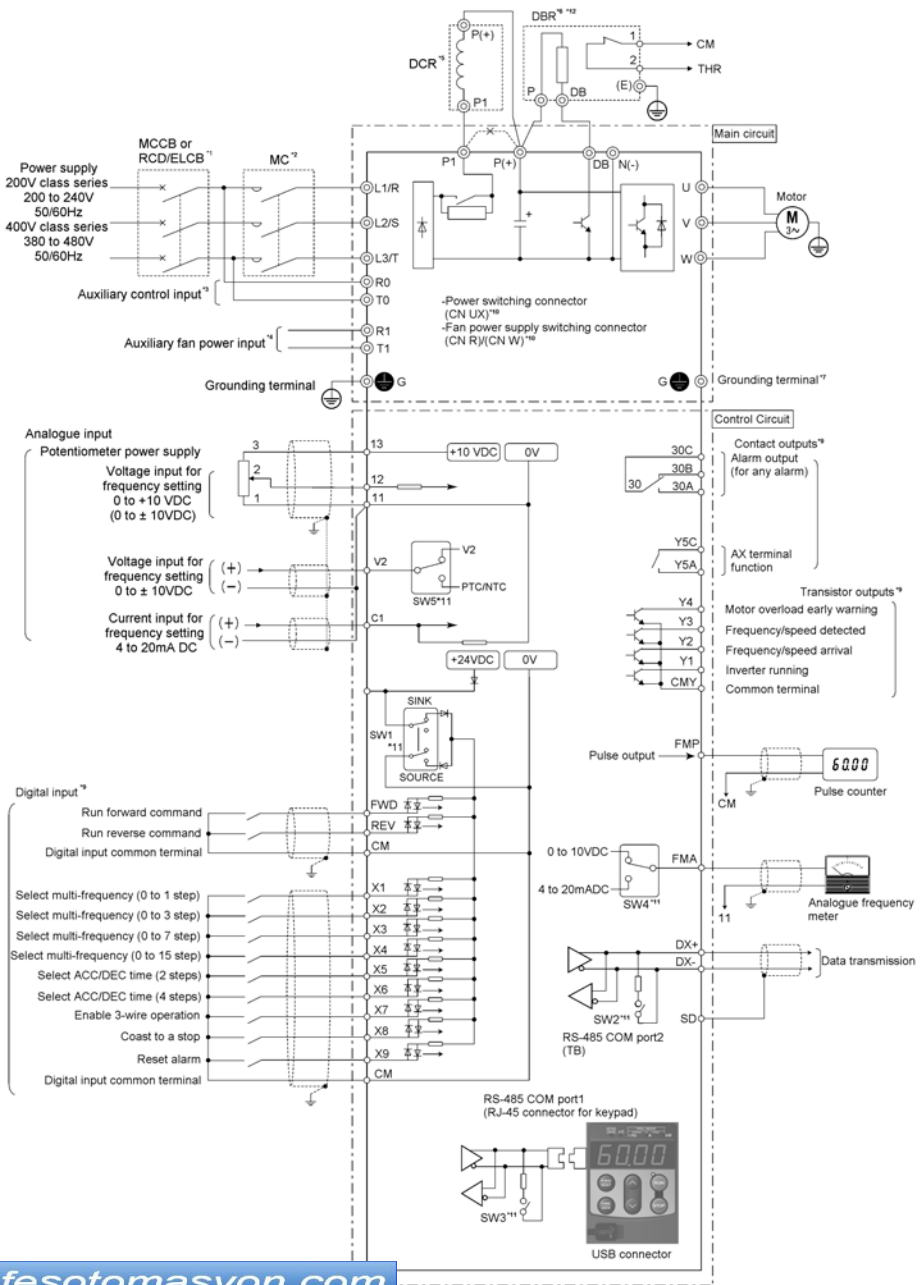

- \*1 Install a recommended molded case circuit breaker (MCCB) or residual-current operated protective device (RCD)/earth leakage circuit breaker (ELCB) (with overcurrent protection function) in the primary circuit of the inverter to protect wiring. Ensure that the circuit breaker capacity is equivalent or lower than the recommended capacity.
- \*2 Install a magnetic contactor (MC) for each inverter to separate the inverter from the power supply, apart from the MCCB or RCD/ELCB, when necessary.  
Connect a surge absorber in parallel when installing a coil such as the MC or solenoid near the inverter.
- \*3 To retain an alarm output signal **ALM** issued on inverter's programmable output terminals by the protective function or to keep the keypad alive even if the main power has shut down, connect these terminals to the power supply lines. Without power supply to these terminals, the inverter can run.
- \*4 Normally no need to be connected. Use these terminals when the inverter is equipped with a high power-factor regenerative PWM converter (RHC series).
- \*5 When connecting an optional DC reactor (DCR), remove the jumper bar from the terminals P1 and P(+).  
Inverters with a capacity of 55kW in LD mode and inverters with 75kW or above require a DCR to be connected. Be sure to connect it to those inverters.  
  
Use a DCR when the capacity of the power supply transformer exceeds 500kVA and is 10 times or more the inverter rated capacity, or when there are thyristor-driven loads in the same power supply line.
- \*6 Connect an external braking resistor (DBR).
- \*7 A grounding terminal for a motor. Use this terminal if needed.
- \*8 For control signal wires, use twisted or shielded-twisted wires. When using shielded-twisted wires, connect the shield of them to the common terminals of the control circuit. To prevent malfunction due to noise, keep the control circuit wiring away from the main circuit wiring as far as possible (recommended: 10cm or more). Never install them in the same wire duct. When crossing the control circuit wiring with the main circuit wiring, set them at right angles.
- \*9 The connection diagram shows factory default functions assigned to digital input terminals [X1] to [X9], [FWD] and [REV], transistor output terminals [Y1] to [Y4], and relay contact output terminals [Y5A/C] and [30A/B/C].
- \*10 Switching connectors in the main circuits. For details, refer to "⑥ Switching connectors" later in this section.
- \*11 Slide switches on the control printed circuit board (control PCB). Use these switches to customize the inverter operations. For details, refer to Section 2.3.7 "Setting up the slide switches" on an instruction manual of inverter.
- \*12 When connecting THR, assign external alarms to digital input terminal (X, FWD, REV terminals).

For terminal details of ① to ③ and ⑥ to ⑧, see an instruction manual of inverter.

④ **DC braking resistor terminals P(+) and DB (for inverters with a capacity of 22kW or below)**

Capacity (kW)	Braking transistor	Optional devices	Option mounting steps required
30 to 160	Built-in	External DC braking resistor	1), 2)

- 1) Connect the terminals P and DB of an optional DBR to terminals P(+) and DB with a wire.
- 2) Arrange the DBR and inverter so that the wiring length comes to 10m or less and twist the two DBR wires or route them together in parallel.

 **WARNING**

When connecting DC braking resistor (DBR), never connect it to terminals other than P(+) and DB.  
**Otherwise, a fire could occur.**

⑤ **DC link bus terminals P(+) and N(-)**

A DC link bus of other inverter(s) or a PWM converter is connectable to these terminals.

 When you need to use the DC link bus terminals P(+) and N(-), consult your Fuji Electric representative.

## 8.1 Standard Model 4 (Braking unit built-in type)

### 8.1.1 Three-phase 200V class series (HD- and LD- mode inverters)

Item		Specifications								
Type(FRN__G1□-2JBU)		30	37	45	55	—	—	—	—	—
Nominal applied motor (kW) *1	HD	30	37	45	55	—	—	—	—	—
	LD	37	45	55	75	—	—	—	—	—
Rated capacity (kVA) *2	HD	45	55	68	81	—	—	—	—	—
	LD	55	68	81	107	—	—	—	—	—
Rated voltage (V) *3		Three-phase 200 to 230 V (with AVR function)								
Rated current (A)	HD	119	146	180	215	—	—	—	—	—
	LD	146	180	215	283	—	—	—	—	—
Overload capability	HD	150%-1min, 200%-3.0s								
	LD	120%-1min								
Voltage, frequency		200~220V, 50Hz, 200~230V, 60Hz								
Allowable voltage/ frequency		Voltage: +10 to -15% (Inter-phase voltage unbalance: 2% or less)*4, Frequency: +5 to -5%								
Required capacity (with DCR)(kVA) *5	HD	40	48	58	71	—	—	—	—	—
	LD	48	58	71	98	—	—	—	—	—
Braking transistor		Built-in				—	—	—	—	—
Minimum connection resistance (Ω) *6		2.5	2.25	2	1.6	—	—	—	—	—
DC reactor (DCR)		Option			*7	—	—	—	—	—
Applicable safety standards		UL508C, C22.2No14, EN61800-5-1:2003								
Enclosure (IEC60529)		IP00, UL open type								
Cooling method		Fan cooling								
Weight/ Mass (kg)		25	32	42	43	—	—	—	—	—

\*1 Fuji 4-pole standard motor

\*2 Rated capacity is calculated assuming the rated output voltage as 220V for 200V class series.

\*3 Output voltage cannot exceed the power supply voltage.

\*4 Voltage unbalance (%) =  $\frac{\text{Max. voltage (V)} - \text{Min. voltage (V)}}{\text{Three-phase average voltage (V)}} \times 67$  (IEC 61800-3)

\*5 Required when a DC reactor (DCR) is used.

\*6 Prepare braking resistor option.

\*7 A DC reactor (DCR) is an option. However, inverters with a capacity of 55kW in LD mode require a DCR to be connected. Be sure to connect it to those inverters.

Three-phase 400V class series (HD-, MD- and LD-mode inverters)

Item		Specifications										
Type (FRN_ _ G1□-4JBU)		30	37	45	55	75	90	110	132	160	—	
Nominal applied motor (kW) <sup>*1</sup>	HD	30	37	45	55	75	90	110	132	160	—	
	MD	—					110	132	160	200	—	
	LD	37	45	55	75	90	110	132	160	200	—	
Rated capacity (kVA) <sup>*2</sup>	HD	45	57	69	85	114	134	160	192	231	—	
	MD	—					160	192	231	287	—	
	LD	57	69	85	114	134	160	192	231	287	—	
Output ratings	Rated voltage (V)	*3 Three-phase 380 to 480 V (with AVR function)										
	Rated current (A)	HD	60	75	91	112	150	176	210	253	304	—
		MD	—					210	253	304	377	—
		LD	75	91	112	150	176	210	253	304	377	—
	Overload capability	HD	150%-1min, 200%-3.0s									
		MD	—					150%-1min				—
LD		120%-1min										
Input power	Voltage, frequency	380~480V, 50/60Hz				380~440V, 50Hz, 380~480V, 60Hz						
	Allowable voltage/frequency	Voltage: +10 to -15% (Inter-phase voltage unbalance: 2% or less)*4, Frequency: +5 to -5%										
	Required capacity (with DCR) (kVA) *5	HD	40	48	58	71	96	114	140	165	199	—
	MD/LD	48	58	71	96	114	140	165	199	248	—	
Braking	Braking transistor	Built-in										
	Minimum connection resistance (Ω) <sup>*6</sup>	10	9	8	6.5	4.7	3.9	3.2	2.6	2.2		
DC reactor (DCR)	Option					*7	Standard attachment					
Applicable safety standards	UL508C, C22.2No14, EN61800-5-1:2003											
Enclosure (IEC60529)	IP00, UL open type											
Cooling method	Fan cooling											
Weight/Mass (kg)	25	26	31	33	42	62	64	94	98		—	

\*1 Fuji 4-pole standard motor

\*2 Rated capacity is calculated assuming the rated output voltage as 440V for 400V class series.

\*3 Output voltage cannot exceed the power supply voltage.

\*4 Voltage unbalance (%) =  $\frac{\text{Max. voltage (V)} - \text{Min. voltage (V)}}{\text{Three-phase average voltage (V)}} \times 67$  (IEC 61800-3)

\*5 Required when a DC reactor (DCR) is used.

\*6 Prepare braking resistor option.

\*7 A DC reactor (DCR) is an option. However, inverters with a capacity of 55kW in LD mode require a DCR to be connected. Be sure to connect it to those inverters.

MEMO

MEMO

**High Performance, Multifunction Inverter**  
***FRENIC-MEGA***

---

**Instruction Manual**

Supplementary for Braking Unit Built-in type  
First Edition, May 2009

Fuji Electric Systems Co., Ltd

---

The purpose of this instruction manual is to provide accurate information in handling, setting up and operating of the FRENIC-MEGA series of inverters. Please feel free to send your comments regarding any errors or omissions you may have found, or any suggestions you may have for generally improving the manual.

In no event will Fuji Electric Systems Co., Ltd be liable for any direct or indirect damages resulting from the application of the information in this manual.

*efesotomasyon.com*

---

## **Fuji Electric Systems Co., Ltd.**

Gate City Ohsaki, East Tower 11-2, Osaki 1-chome, Shinagawa-ku, Tokyo, 141-0032, Japan

Phone: +81 3 5435 7283 Fax: +81 3 5435 7425

URL <http://www.fesys.co.jp/eng/>