

Unidrive SP

Solutions Platform (1-40HP)

Unidrive SP

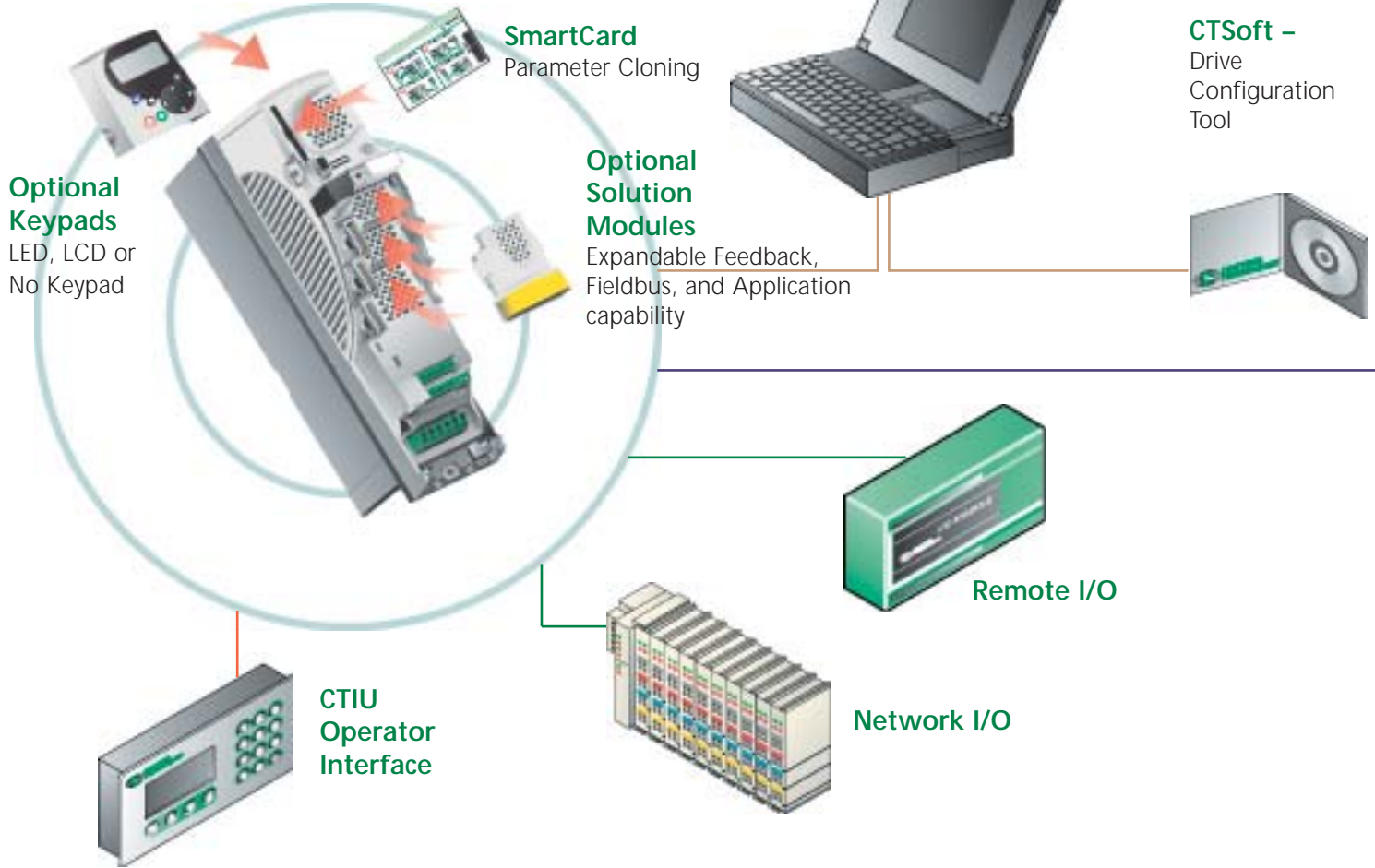

THE BENCHMARK



Keypad Options

- SM-NKP No Keypad
- SM-LED Keypad
- SM-LCD Keypad Plus *(can be mounted in remote location)*

Feedback Modules

- SM-Uni Encoder
- SM-Encoder Plus
- SM-Resolver

Fieldbus Modules

- SM-DeviceNet
- SM-Profibus
- SM-Interbus
- SM-CANOpen

Control and Application Modules

- SM-I/O Plus
- SM-Applications (with CTNet)
- SM-Apps Lite
- SM-EZMotion

Typical Heavy Duty Applications

Elevator Control

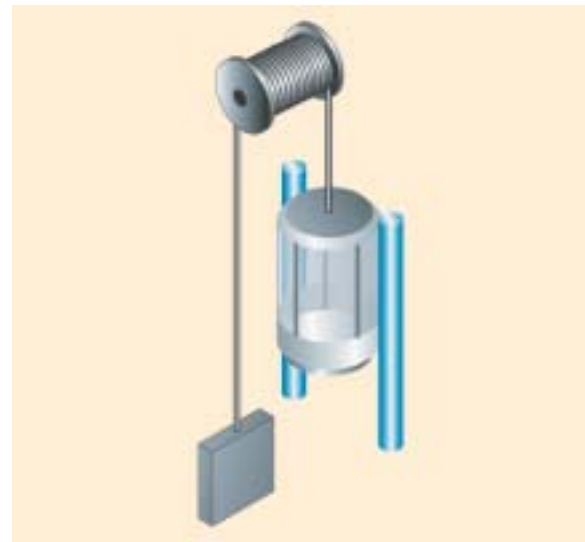

Wire Drawing

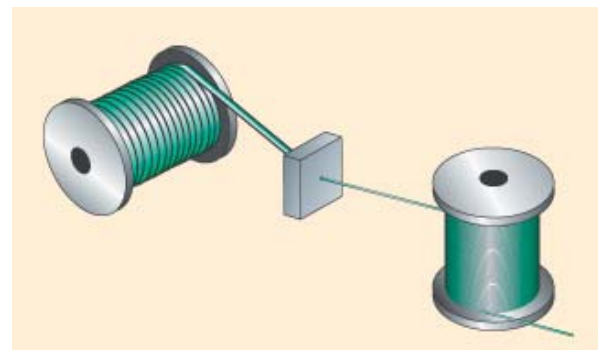

Bridle Control

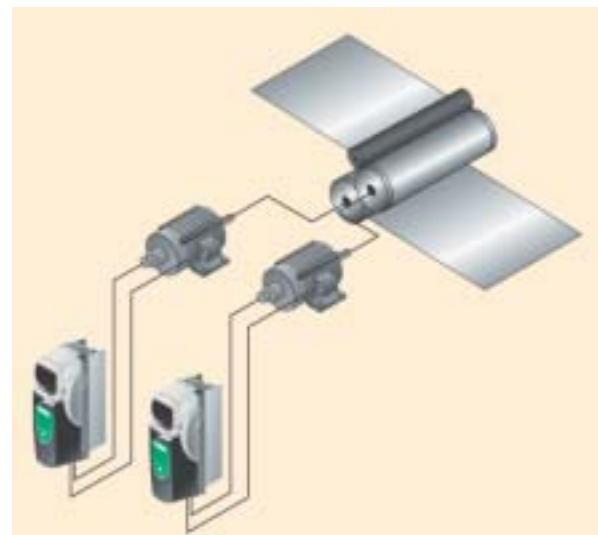

SyPT Lite-
Drive
Programming
Software



SyPT -
System
Programming
ToolKit
(IEC-61131-3)



PowerTools Pro-
"Motion Made Easy™"
Windows™-based
Programming for
Motion Applications



**AC Induction
Motor**

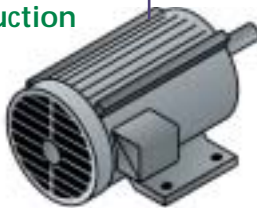

Vector Motor

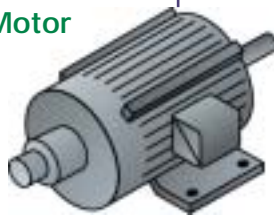

Servo Motor

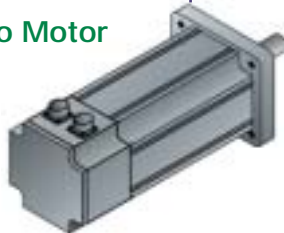

Unidrive SP

Solutions Platform

Unidrive SP

The Unidrive SP creates "The Benchmark" for AC drive and servo controls in the automation industry. It is a truly scalable "Solutions Platform" with the flexibility to be personalized to your requirements, and lower your true total cost while maximizing your productivity.

The Unidrive SP "Solution Platform" incorporates many cost saving and performance improvements based on input from end users and OEMs, including Secure Disable, Multiple Fieldbus capability, on-board EMC filter, Universal feedback device support, and the facility for up to three Solution Modules to tailor the drive to specific application needs. Normal and Heavy-Duty operation and enhanced servo performance make the Unidrive SP the ideal "Solutions Platform."



Typical Normal Duty Applications

—Extruder

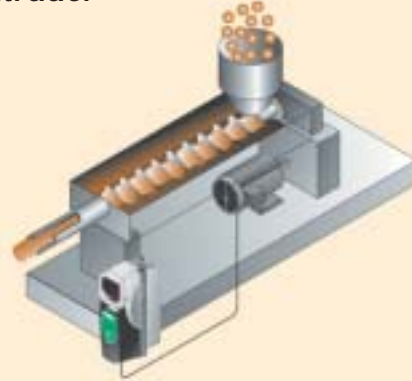

—Conveyor



—Pump

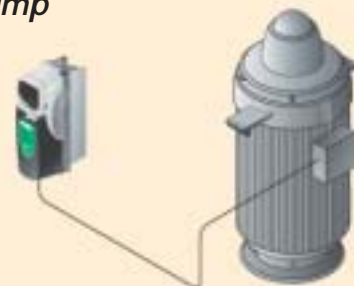

- Digital AC Drive
- 1 to 20 HP, 3 Phase, 208-230 VAC
- 1 to 40 HP, 3 Phase, 380-460 VAC
- 2 to 25 HP, 3 Phase, 575 VAC (Size 3)
- Five operating modes with energy-saving Power Factor Control in Regen Mode*
- Secure Disable for contactor elimination
- SmartCard – Parameter Cloning Card
- Universal Feedback Interface with 14 Selectable Modes
- High Resolution Analog Input
- RJ45 connector for PC Interface
- Dual duty ratings: Normal and Heavy
- Three Zero-space Universal Option Slots
- All Other Unidrive Standard Features
- Complete Motor Solutions



*Note: Additional components are necessary to produce a regen drive package.



Unidrive SP — Incorporating “Benchmark” Technologies

Secure Disable

The Unidrive SP Secure Disable function meets the requirements of EN954-I : category 1, 2, and 3 for machine safety, and can serve as a part of a category 4 application. Control Techniques’ Secure Disable safety solution has been independently verified by the German safety organization, BIA. This exclusive feature of the Unidrive SP saves money and space. Under many conditions, this standard feature eliminates the need for safety contactors by utilizing secure circuitry to prevent the motor shaft from being driven by the drive.



A handbook is available from Control Techniques to assist in the application of this product feature.

—Secure Disable

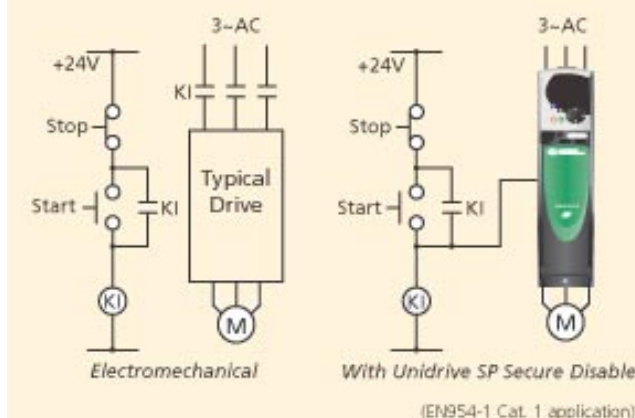

Multiple Fieldbus Capability

The Unidrive SP provides unrivaled fieldbus flexibility. In addition to the standard Modbus RTU port, up to three fieldbus option modules can be installed in the Unidrive SP’s option slots. This provides the capability to control and monitor a Unidrive SP on multiple fieldbus networks. For example, a single Unidrive SP can be configured to communicate on both DeviceNet and Profibus networks simultaneously.

In the example shown, CTNet is used to provide real-time coordination between two Unidrive SP modules. The DeviceNet and Profibus connections allow data to be passed the controllers in a machine line.

—Multiple Fieldbus

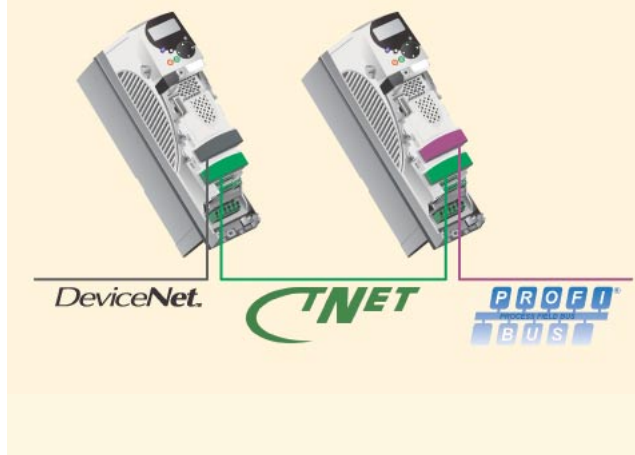

—Scaleable PLC Functionality

Zero-Space Scalable PLC Functionality

In addition to the extensive drive configuration capabilities of the UnidriveSP, scalable programming is available to solve virtually any application requirements. Simple logic function programming is achieved using SyPT Lite software and the drive’s built in PLC. More complex systems can be solved by adding SM-Apps Lite (with SyPT Lite or SyPT) and SM-Applications (SyPT only) option modules.

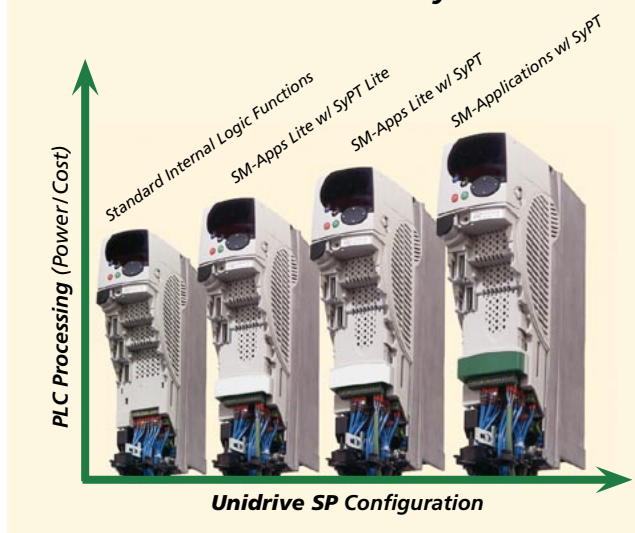

Unidrive SP



Feature

Performance Advantage

Dual Duty Ratings—Normal and Heavy

Provides cost effective sizing choices for all applications

48V DC Main Power Supply Input

Ideally suited for elevator rescue and machine tool set up

24V DC Auxiliary Power Supply Input

Provides an additional means of maintaining control, fieldbus and position loop on mains loss

Comprehensive Autotune

Inertia monitoring and static autotune reduce startup time

Universal Feedback Interface

Supports 14 different feedback configurations, including several absolute encoders. No need for additional components

High Resolution Analog Input

16-bit, 250 μ sec interface for high performance applications

Extensive Fieldbus Connectivity

ModbusRTU (Standard). Profibus-DP (12Mbit), DeviceNet, CANOpen, Interbus-S and CTNet optional via zero-space SM modules

Up to four fieldbuses can connect to a single drive, eliminating the need for expensive gateways

Three Universal Option Slots

Fieldbus, control and application SM modules fit in any of the three option slots beneath the drive cover

Secure Disable Function

Conforms to IEC954-1 Category 3 for machine safety with system cost reduction

SmartCard for Simple Setup and Cloning

Easy-to-use card stores drive configuration for simple startup and parameter cloning.

Keypad Options

Choose no keypad, LED keypad or LCD keypad based on the system design and operating environment

Drive Mounted Brake Resistor

Unidrive SP sizes 1 and 2 feature a drive mounted brake resistor option to reduce panel space requirements

All of the Standard Features of the Unidrive*

- 5 Operating modes: V/Hz, open loop vector, closed loop vector, servo, and regen
- 32-bit application coprocessor module**
- Encoder feedback as standard
- Application functions for PID, Torque control, Brake control, Preset speeds, MOP, Axis-limit control and Digital Lock
- Built-in shaft orientation mode
- Digital lock with adjustable ratio (frequency slaving)
- Programmable boolean logic (AND, NAND, OR, NOR) gates with delay outputs
- Programmable threshold comparators
- Built-in PID controller
- S-ramp accel / decel profiling
- Built-in MOP (motorized potentiometer)
- 8 Preset speeds and independent accel / decel rates
- 3 Skip frequencies with adjustable bandwidths
- Run time chronometers
- Configurable analog and digital I/O
- Selectable Stopping modes including Coast, Ramp, and DC injection
- Dynamic Braking capability
- Removable control terminals common to all sizes

Feature Enhancements to Unidrive SP

- Output frequencies up to 3000 Hz
- Intelligent Thermal Management (ITM) technology with switching frequencies up to 16 kHz

* See page 42 for more detail on Unidrive features.

** The Unidrive SP employs SM modules, which provide users with more configuration options and flexibility. See section that begins on page 35.

Ratings: Unidrive SP

		Motor HP ①	Continuous Output Current	Peak Output Current	Motor HP ①	Continuous Output Current	Peak Output Current	Peak Output Current
208 / 230 VAC		Normal Duty			Heavy Duty			
Catalog No.	Frame Size	HP@230V	I _N (A)	(A)	HP@230V	I _H (A)	Open loop (A)	Closed loop (A)
SP1201-XXX	1	1.5	5.2	5.7	1	4.3	6.5	7.5
SP1202-XXX		2	6.8	7.5	1.5	5.8	8.7	10.2
SP1203-XXX		3	9.6	10.6	2	7.5	11.3	13.1
SP1204-XXX		3	11.0	12.1	3	10.6	15.9	18.6
SP2201-XXX	2	5	15.5	17.1	3	12.6	18.9	22.1
SP2202-XXX		7.5	22.0	24.2	5	17.0	25.5	29.8
SP2203-XXX		10	28.0	30.8	7.5	25.0	37.5	43.8
SP3201-XXX	3	15	42.0	46.2	10	31.0	46.5	54.3
SP3202-XXX		20 ②	54.0	59.4	15 ②	42.0	63.0	73.5
380 / 480 VAC		Normal Duty			Heavy Duty			
Catalog No.	Frame Size	HP@460V	I _N (A)	(A)	HP@460V	I _H (A)	Open loop (A)	Closed loop (A)
SP1401-XXX	1	1.5	2.8	3.1	1	2.1	3.2	3.7
SP1402-XXX		2	3.8	4.2	2	3.0	4.5	5.3
SP1403-XXX		3	5.0	5.5	3	4.2	6.3	7.4
SP1404-XXX		5	6.9	7.6	3	5.8	8.7	10.2
SP1405-XXX		5	8.9	9.7	5	7.6	11.4	13.3
SP1406-XXX		7.5	11.0	12.1	5	9.5	14.3	16.6
SP2401-XXX	2	10	15.3	16.8	10	13.0	19.5	22.8
SP2402-XXX		15	21.0	23.1	10	16.5	24.8	28.9
SP2403-XXX		20	29.0	31.9	20	25.0	37.5	43.8
SP3401-XXX	3	25	35.0	38.5	25	32.0	48.0	56.0
SP3402-XXX		30	43.0	47.3	30	40.0	60.0	70.0
SP3403-XXX		40 ②	56.0	61.6	30 ②	46.0	69.0	80.5
575 VAC		Normal Duty			Heavy Duty			
Catalog No.	Frame Size	HP@575V	I _N (A)	(A)	HP@575V	I _H (A)	Open loop (A)	Closed loop (A)
SP3501-XXX	3	3	5.4	5.9	2	4.1	6.2	7.2
SP3502-XXX		5	6.1	6.7	3	5.4	8.1	9.5
SP3503-XXX		7.5	8.4	9.1	5	6.1	9.2	10.7
SP3504-XXX		10	11.0	12.1	7.5	9.5	14.3	16.6
SP3505-XXX		15	16.0	17.6	10	12.0	18.0	21.0
SP3506-XXX		20	22.0	24.2	15	18.0	27.0	31.5
SP3507-XXX		25	27.0	29.7	20	22.0	33.0	38.5

- ① Motor HP based on four pole, 230 / 460 / 575 VAC typical motor ratings. Select model based on actual motor full load current
- ② For applications requiring higher HP refer to the Unidrive section, which follows this section.

Normal Duty (open loop)	Suitable for most applications, current overload is set at 110% for 60 sec.*
Heavy Duty (open loop)	Suitable for more demanding applications, current overload is set at 150% for 60 sec.*
Heavy Duty (closed loop or servo)	Suitable for demanding applications, current overload is set at 175% for 20 sec.*

* Where motor rated current is less than the drive rated continuous current, higher overloads are achieved.

Order String

SP X X XX -XXX

KeyPad: LED, LCD or NKP (no keypad)

Model: 01, 02, 03, 04, 05, 06, 07

Drive Voltage Rating: 2 = 208-230 VAC

4 = 380-460 VAC

5 = 575 VAC

Size: 1, 2, 3

Unidrive SP Product Family

Terminal Diagram: Unidrive SP

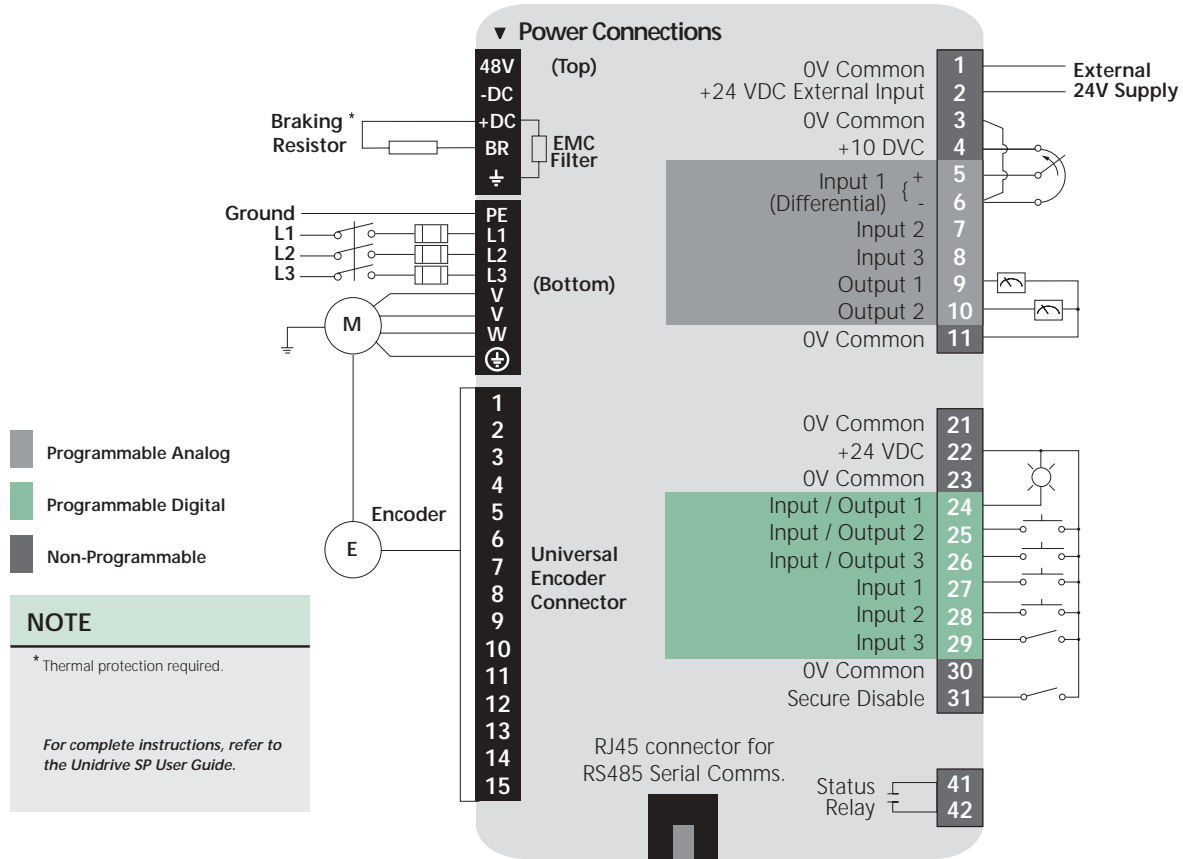

Terminal Description

Pin#	Function ①	Type/Description	Notes
1	0V Common		
2	+24 VDC External Input	Back up Power Supply for Control	60W, 24 VDC
3	0V Common	Common for External Analog Devices	
4	+10 VDC	Reference Supply	10 mA max
5	Analog Input 1 (Local Frequency / Speed Reference), 16 bit	Differential Analog Input, Non-inverting Input	±10 VDC 100k Ohms
6	Analog Input 1 (Local Frequency / Speed Reference), 16 bit	Differential Analog Input, Inverting Input	±10 VDC 100k Ohms
7	Analog Input 2 (Remote Frequency / Speed Reference), 10 bit	Single-ended Analog Input	±10 VDC, 100k Ohms or 4-20 mA②, 200 Ohms
8	Analog Input 3 (Motor Thermistor), 10 bit (Trip at 3.3kOhm)	Single-ended Analog Input	±10 VDC, 100k Ohms or 4-20 mA②, 200 Ohms
9	Analog Output 1 (Frequency / Speed Monitor)	Single-ended Analog Output, Bi-polar	±10 VDC or 0-20 / 4-20mA
10	Analog Output 2 (Motor Torque Monitor)	Single-ended Analog Output, Bi-polar	±10 VDC or 0-20 / 4-20mA
11	0V Common	Common for External Analog Signals	

Pin#	Function ①	Type/Description	Notes
21	0V Common		
22	+24 VDC	User Supply	200 mA max
23	0V Common	Common for External Digital Inputs	
24	Digital I/O 1 (Zero Speed Output)	Digital Input / Output	0 to 24 VDC input, or 1 to 24 VDC, 100 mA max output
25	Digital I/O 2 (Reset Input)	Digital Input / Output	0 to 24 VDC input, or 1 to 24 VDC, 100 mA max output
26	Digital I/O 3 (Run Forward Input)	Digital Input / Output	0 to 24 VDC input, or 1 to 24 VDC, 100 mA max output
27	Digital Input (Run Reverse)	Digital Input	0 to 24 VDC, 7.5k Ohms
28	Digital Input (Local / Remote)	Digital Input	0 to 24 VDC, 7.5k Ohms
29	Digital Input (Log)	Digital Input	0 to 24 VDC, 7.5k Ohms
30	0V Common	Common for External Digital Inputs	
31	Digital Input (Secure Disable)	Digital Input	0 to 24 VDC, 1µsec sample
41	Status Relay (Drive Healthy)	Normally Open	240 VAC, 2A resistive
42	Status Relay (Drive Healthy)	Normally Open	240 VAC, 2A resistive

Programmable Analog (Grey) Programmable Digital (Green) All Analog I/O is scaleable

① Values in parenthesis designate default functions
② 0-20, 20-0, and 20-4 mA are also available. See Unidrive SP Manual.

Specifications: Unidrive SP

Environment	
Ambient Operating Temperature	0° to 40°C (32° to 104°F) 0° to 50°C (32° to 122°F) with derating
Cooling method	Forced convection
Humidity	95% maximum non-condensing at 40°C (104°F)
Storage Temperature	-40° to 50°C (-40° to 122°F)
Altitude	0 to 3000m (9,900 ft). Derate 1% per 100m (328 ft) between 1000m (3280 ft) and 3000m (9,900 ft).
Vibration	Tested in accordance with IEC 68-2-34
Mechanical Shock	In accordance with IEC 68-2-27
Enclosure	NEMA 1 (IP 20), NEMA 12 (IP 54) through panel mounting
Electromagnetic Immunity	In compliance with IEC801 and EN50082-2, and complies with EN61800-3 with built-in filter
Electromagnetic Emissions	In compliance with EN50081-2 when the recommended RFI filter is used and EMC installation guidelines are followed

AC Supply Requirements

Voltage	200 to 240 VAC ±10% 380 to 480 VAC ±10% 500 to 575 VAC ±10%
Phase	3Ø
Phase Imbalance Tolerance	2% negative phase sequence (equivalent to 3% voltage imbalance between phases)
Frequency	48 to 65 Hz
Input Displacement Power Factor	0.93

Control

Carrier Frequency	3, 4, 6, 8, 12, 16 kHz
Output Frequency	0 to 3000 Hz (Open loop)
Output Speed	0 to 40,000 RPM (Closed loop)
Frequency Accuracy	±0.01% of full scale
Frequency Resolution	0.001 Hz
Analog Input Resolution	16 Bit + sign (Qty 1), 10 Bit + sign (Qty 2)
Serial Communications	2 or 4-wire RS232 or RS485. Protocol is ANSI x 3.28-2.5-A4, or Modbus RTU Baud rate 300 to 115,200.
Braking	DC injection braking (stopping and holding) standard. Dynamic braking transistor standard.
Control Power Ride Through	Up to 1 second depending on inertia and decel time

Protection

DC Bus Undervoltage Trip	175 / 350 / 435 VDC (approximately 124 / 247 / 307 VAC line voltage)
DC Bus Overvoltage Trip	415 / 830 / 990 VDC (approximately 293 / 587 / 700 VAC line voltage)
MOV Voltage Transient Protection	160 Joules, 1400 VDC clamping (Line to line and line to ground)
Drive Overload Trip	Current overload value is exceeded. Programmable for Normal Duty or Heavy Duty, Open loop or Closed loop operation

Instantaneous Overcurrent Trip	225% of drive rated current
Phase Loss Trip	DC bus ripple threshold exceeded
Overtemperature Trips	Drive heatsink, control board, and option module(s) monitoring
Short Circuit Trip	Protects against output phase to phase fault
Ground Fault Trip	Protects against output phase to ground fault
Motor Thermal Trip	Electronically protects the motor from overheating due to loading conditions

Approvals & Listings

UL, cUL	UL File #E171230
IEC	Meets IEC Vibration, Mechanical Shock and Electromagnetic Immunity Standards
CE	Designed for marking
NEMA	NEMA 1 enclosure type
VDE	Meets VDE Electromagnetic Emissions Standards
ISO 9002	Certified Manufacturing Facility

Dimensions

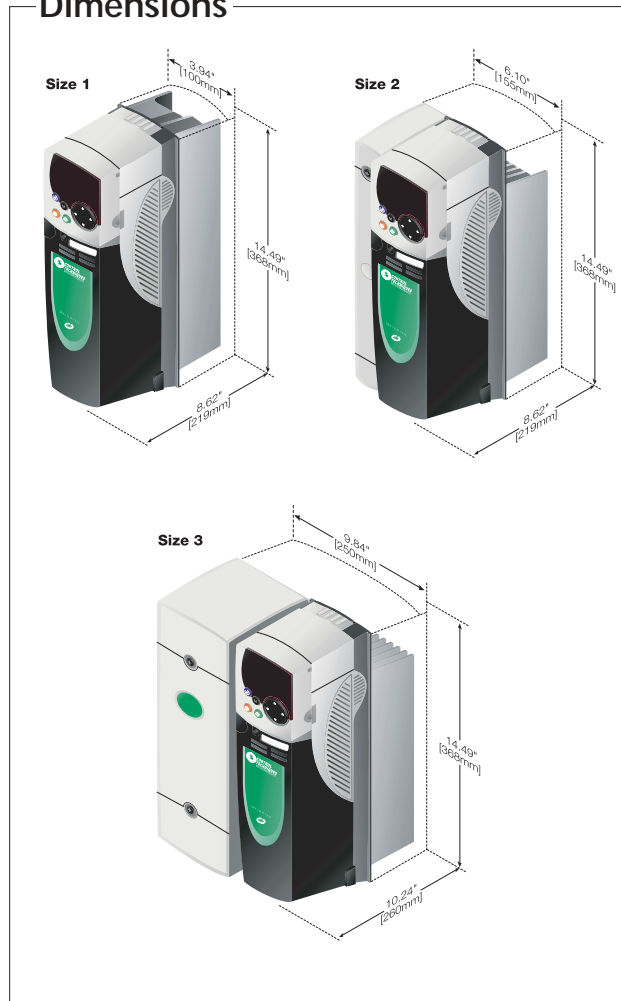

Unidrive SP

Options / Software / Accessories

Unidrive SP

The Unidrive SP provides application and system designers with an incredibly flexible drive platform, which is easily modified by an extensive range of sophisticated SM option modules that can be used singly or in combination for economical and space saving solutions. SM option modules install easily into any of the three option slots, with no tools required. The I/O, feedback, memory, communication and application modules enable the SP drive to be easily and affordably tailored to meet the specific environmental and performance demands of your application.

A complete range of other accessories are available to enhance operation and meet system design criteria.



At-A-Glance

Option	Description	Catalog Number
Motor Feedback	Universal Encoder Feedback Second Encoder Feedback Resolver Input Feedback	SM-Uni Encoder SM-Encoder Plus SM-Resolver**
Memory	Cloning/Program Storage Card	SmartCard
Input/Output	Extended I/O Remote I/O (page 151) CTNet Network I/O (page 145)	SM-I/O Plus I/O Box Beckhoff I/O
Application Coprocessor	System Programming Motion Made Easy Servo	SM-Applications SM-Apps Lite SM-EZMotion**
Communication	Modbus RTU (Standard) Profibus-DP Interbus-S DeviceNet CTNet CANopen	SM-Applications* SM-Profibus SM-Interbus SM-DeviceNet SM-Applications SM-CANopen
PC to Drive Accessories	Configuration Tool Communications Cable	CTSoft CT Comms Cable
Operator Interface	LED Keypad Backlit LCD Keypad	SM-Keypad SM-Keypad Plus
Extended Warranty	Extends 2 year warranty to 5 years	SP1WE — SP3WE

*Provides additional Modbus RTU port.
**Only one of these modules per drive.

Drive Configuration and Programming

SmartCard

This is a **standard** feature that enables simple configuration of parameters in a variety of ways. The SmartCard can:

- 'Clone' a complete set of parameters for serial production
- Set up an application as parameter differences from default
- Automatically save all user parameter changes for maintenance purposes
- Load complete motor map parameters

The SmartCard is located at the top of the module under the drive display (if fitted) on the left-hand side.



The drive only communicates with the SmartCard when commanded to read or write, meaning the card may be "hot swapped".

The SmartCard can also be used for:

1. Parameter cloning between drives
2. Saving complete drive parameter sets (up to four)
3. Saving parameter set differences from default
4. Storing ladder logic programs

499 data block locations (1 to 499) are available to the user for storing data up to the maximum capacity of 4kb.

500 data block locations (500 to 999) are read only data blocks for predefined parameter sets or macros. These data blocks cannot be written to by the user.

Drive Configuration Tool (CTSoft)

CTSoft is a complimentary Windows based drive configuration tool designed to enable the complete control and display of all parameters within a Unidrive or Unidrive SP. Functions within CTSoft allow data to be uploaded, viewed and saved, or retrieved from disk, modified and printed. It can be used off-line in the office or on-line in the plant. CTSoft communicates with the Unidrive SP via the computer's serial port to the drive's RS485 port using a communications cable (CT Comms cable). For more information, refer to the Accessories Section on page 138.

Some of CTSoft's capabilities include:

- Remote Upload/Download
- Parameter Saving
- Drive and SM-Application Reset
- Monitor Screens
- Multiple Window Display
- Block Diagram Animation
- Project Storage

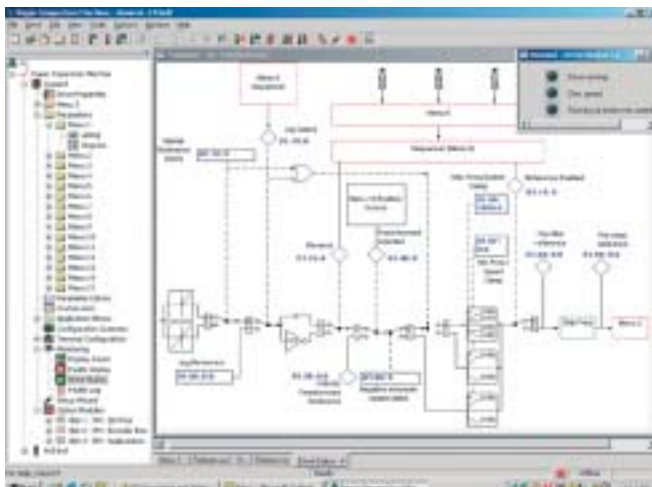

Extended Warranty

An industry-leading two-year warranty is standard for Unidrive SP drives. An extended warranty is available that increases the warranty period to five years.

Unidrive SP Size	Catalog Number
1	SP1WE
2	SP2WE
3	SP3WE



Programming / Configuration Cable

Using a special RS232 to RS485 converter you can connect the PC to the RJ45 serial port on the front of the drive. A special pre-made cable is available from Control Techniques for this purpose – this same cable is used with other Control Techniques – products that use a RJ45 RS485 connector such as the Commander SE.

The RJ45 socket is located under a small flap on the front of the Unidrive SP just below the keypad. The pin-outs of this connector are described in the Unidrive SP User Guide.



Catalog Number	Description
CT Comms Cable	PC-to-drive Comms Cable

Operator Interface

Keypad Options

The Unidrive SP can operate without a keypad, or with either the SM-Keypad or SM-Keypad Plus. The SM-Keypad is a full-function, 7-digit LED data display. The SM-Keypad Plus is a back-lit LCD display option that can be remote mounted, has dual language, on-line help, and HMI features. Both keypads are “hot-pluggable,” enabling them to be moved from one drive to another without powering down.

SM-Keypad



SM-Keypad Plus



Operator Interface Unit (CTIU)

The CTIU operator interface units have a back-lit LCD display and five easy-to-use navigation keys.



Using the intuitive “WYSIWIG” page editor, they can be programmed to display a variety of menus, submenus, alarms, fault conditions and other critical information. The CTIUs support a range of capabilities including multiple font sizes, real time trends and graphs, scheduling and background programs. They communicate* via Modbus RTU and, to simplify installation, CTIUs are rated NEMA 4/12 and require no screw mounting holes.

RS485 cables are available for connection to either the standard RJ45 port, or to the communications terminals on an SM-Applications option module.

For more information, refer to the Accessories Section on pages 152-153.

Zero-Space Power Accessories

SM-Heatsink DBR (1&2)

Dynamic braking resistors are available for heatsink mounting on size 1 and 2 drives. No external thermal protection device is required as these devices will fail safely under fault conditions. Overload protection is preconfigured in software for using SM-Heatsink DBR1 with UnidriveSP size 1, and SM-Heatsink DBR2 with UnidriveSP size 2.

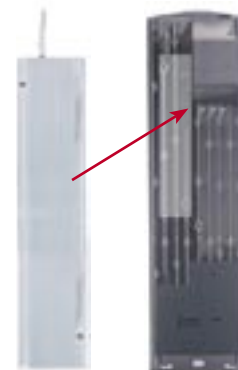

Size 1 Unidrive SP heatsink shown

UnidriveSP Size	DBR Model No.	DC Resistance	Average Power
1	SM-Heatsink DBR1	75 Ω	50W
2	SM-Heatsink DBR2	37.5 Ω	100W

For applications requiring greater braking power, or other Unidrive SP sizes please refer to the Accessories section of this catalog, page 161.

On-board EMC Filter

An internal EMC filter is provided as **standard** with the Unidrive SP. It is adequate for most industrial applications. The filter conforms to EN61800-3 (second environment) when motor cable length does not exceed 13 feet (4 meters).



For installations where it is deemed necessary, Control Techniques provide a range of additional external EMC filters (see page 165). These external, surface mount filters have all been assessed for conformance with the EMC directive, by testing to the appropriate international standards.

Universal Motor Feedback

The Unidrive SP has a built-in Universal encoder port that accepts the following signal types:

- Quadrature Incremental
- Pulse and Direction
- Forward and Reverse Pulses
- Quadrature with commutation
- Forward and Reverse Pulses with commutation
- SinCos without commutation
- Absolute SinCos using Stegman EI485 serial protocol
- Absolute EnDat encoder
- Absolute SinCos using EnDat serial communications protocol
- Absolute SSI encoder

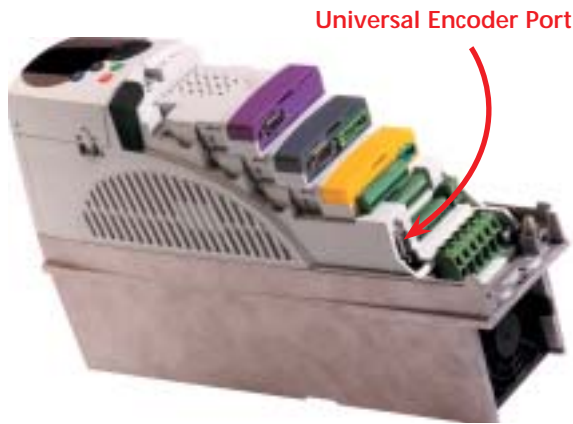

Encoder Terminal Connector (SM-ETC)

The SM-ETC is used to simplify motor feedback wiring by "Breaking out" the 15-pin D-connector signals to screw terminals.



SM-ETC

SM-Uni Encoder

The SM Uni Encoder module provides the Unidrive SP with an additional feedback port with the same functionality as the base drive, plus a simulated encoder output that can be programmed to operate in the following modes:



- Quadrature Incremental
- Pulse and Direction
- SSI

The module also incorporates freeze inputs for applications requiring position capture.

SM-Encoder Plus

The SM-Encoder Plus module provides an additional incremental encoder feedback port.



Note: More than one SM-Encoder Plus and/or SM-Uni Encoder module may be installed in a single drive.

SM-Resolver

This module enables the Unidrive SP to control the speed and position of motors outfitted with resolvers. Because of their ruggedness, resolvers are often used in hot, demanding environments.



- Input Impedance:* >85 Ohms
- Transformation Ratio:* 3:1 or 2:1
- Excitation Frequency:* 6kHz
- Excitation Voltage:* 6V or 4V rms sine wave

Maximum Motor Speed	Feedback Resolution	Simulated Encoder Output (LPR)	
		Quadrature Format	Frequency & Direction
0-3,300 RPM	14 bit	4096	8192
3,301-13,200 RPM	12 bit	1024	2048
13,201-40,000 RPM	10 bit	256	512

The encoder simulated output can be sourced either from the resolver or the main drive encoder.

Input/Output

SM-I/O Plus

This module enables the drive system designer and the Unidrive to solve more complex applications by providing additional inputs and outputs that the Unidrive SP can access locally. These connections on 12-pin and 3-pin removable terminal strips are programmable using CT Soft or the drive's keypad. Their assignments are stored within the drive's memory.



SM I/O Terminal Diagram

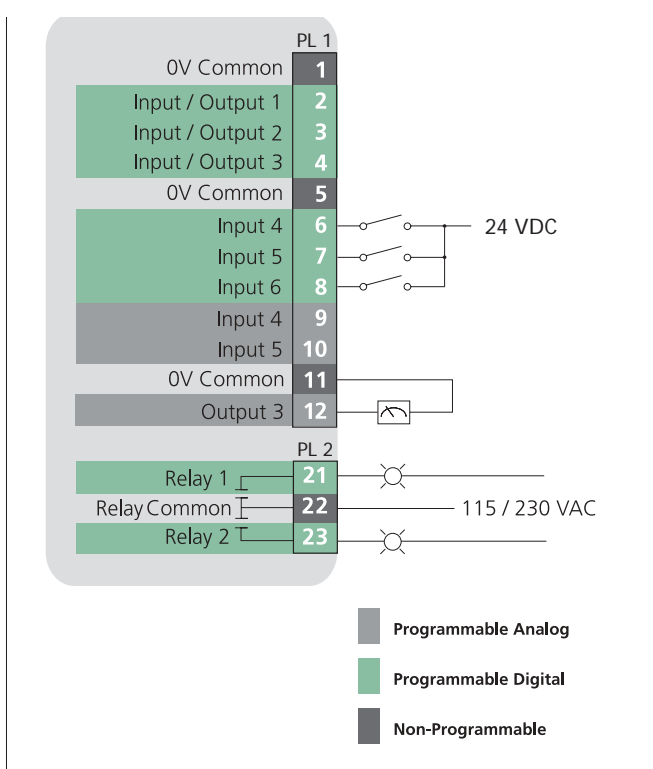

SM I/O Terminal Description

Quantity	Description	Notes
2	Relay Contacts (N.O.)	110 VAC, 2 A resistive
3	Digital Input	+24 VDC, 7.5k Ohms
3	Digital Input / Output	+24 VDC, 7.5k Ohms / +24 VDC @ 10 mA max.
2	Analog Voltage Input	±10 VDC, 20k Ohms, 10 bit
1	Analog Voltage Output	±10 VDC @ 30 mA max., 10 bit

SM Network Communication Modules

The Unidrive SP has a standard Modbus RTU RS485 port. In addition, SM network communication interface modules can be inserted in any one of the three option slots, allowing up to three fieldbus option modules to be installed in the Unidrive SP's option slots. This provides the capability to control and monitor a Unidrive SP on multiple fieldbus networks. The Modbus-RTU port can be used for drive configuration using CTSoft or applications programming using SyPT, SyPT Lite or PowerTools.



Communications Protocol	Interface Module Catalog Number	System Configuration
Modbus RTU*	SM-Applications	Master/Slave
Profibus-DP	SM-Profibus	Master/Slave
Interbus-S	SM-Interbus	Master/Slave
CTNet	SM-Applications	Peer-to-Peer
DeviceNet	SM-DeviceNet	Master/Slave
CANOpen	SM-CANOpen	Master/Slave

*Modbus RTU is standard. An additional Modbus RTU port can be provided with an SM-Applications module.

Application Modules

SM-Applications

The SM-Applications module contains a high-speed microprocessor which provides a low-cost facility for a system designer to write application specific programs without needing a PLC or other stand-alone controller. The module is programmed (via CTNet or the drive's RJ45 port) using our Control Techniques SyPT (System Programming Toolkit), which complies with IEC 61131-3 Ladder, Function Block or DPL (Drive Programming Language).



The SM-Applications module and SyPT provide an extremely flexible programmable solution for velocity, torque and position control systems.

The module uses dual port RAM to interface to the drive's main processor, providing intimate high-speed bi-directional access. It can read and modify any parameter within the drive, enabling customized real-time calculations under a multi-tasking run-time environment. The 32-bit RISC processor and 384K of user program FLASH memory (equivalent to >5000 lines of ladder logic or basic instruction code) provide a powerful base for a designer to accomplish complex algorithms for demanding time-critical process control.

The optically isolated RS485 port serves as a communication port for our CTIU operator interface units. It is fully configurable, supporting many communication modes including an ANSI 2 or 4-wire protocol at data rates up to 19.2kbaud. A Modbus protocol with RTU and ASCII slave modes is also available.

The module also has two digital inputs and two digital outputs for high-speed I/O operations, such as registration capture and flying shear firing.

SM-Apps Lite

The SM Apps Lite module provides the user with an intermediate applications solution. It performs many of the functions of the SM-Applications module. The module can be programmed with either SyPT or SyPT Lite depending upon the scale of program required. SyPT Lite supports approximately 100 lines of ladder and SyPT supports 1,000 lines of ladder, Function Block or DPL See page 142 for more information on SyPT Lite.



SM-EZMotion

The SM-EZMotion is ideal for all of your motion control applications whether simple or highly complex. Windows™-based PowerTools Pro configuration software helps to make all applications easy while maintaining flexibility and functionality.



The module is equipped with four digital inputs and two digital outputs for external control. Simplify all of your motion applications by using the built-in High-Speed Capture, Queuing, Profile Summation, and Program Multitasking capabilities.

Ease of use defines this multipurpose motion controller. Take advantage of all its features to quickly solve these applications:

- Simple Indexing
- Pick and Place
- Flying Cutoff—Flying Shear
- High Speed Labeling
- Phase Synchronization
- Random Infeed Control
- Rotary Knife
- And many more...