

Standard Specifications

Environmental Conditions

Enclosure	IP20
Installation Location	Do not install in locations where product could be exposed to dust, corrosive gas, inflammable gas, oil mist, vapor, water drops or direct sunlight. There must be no salt in the atmosphere. Condensation must not be caused by sudden changes in temperature. For use at altitudes of 3300 ft. (1000m) or less without derating.
Ambient Temperature	-10 to +50°C (+14°F to 122°F)
Ambient Humidity	5 to 95% RH (non-condensing)
Vibration	3mm: 2 to less than 9 Hz 9.8 m/s ² : 9 to less than 20 Hz 2 m/s ² : 20 to less than 55 Hz 1 m/s ² : 55 to less than 200 Hz
Storage Temperature	-25°C to +65°C (-4°F to 149°F)
Cooling Method	0.12 to 1 Hp - Convection 2 Hp and greater - forced air (integral fan)

Input Frequency

Power System	200-230 VAC, three phase, 50-60 Hz +10% to -15% V, +5% to -5% Hz
--------------	--

Output Frequency

Setting	Maximum frequency: 50 to 120 Hz (in 1 Hz steps) Base frequency: 25 to 120 Hz (in 1 Hz steps) Starting frequency: 1 to 6 Hz (in 1 Hz steps)
Accuracy (Stability)	Digital setting: ±0.01% of maximum frequency (from -10°C to +50°C) Analog setting: ±1.0% of maximum frequency (at 25°C ± 10°C)
Setting Resolution	Digital setting: 0.1 Hz (99.9 Hz or less), 1 Hz (100 Hz or more) Analog setting: 1/256 of maximum frequency (ex. 0.23 Hz/60 Hz; 0.47 Hz/120 Hz)

Control

Control Method	Sinusoidal PWM control (with simplified current vibration suppression)
Operation Method	Keypad operation: RUN or STOP key Input signal: Forward/Reverse command, Coast-to-stop command, Trip command (external alarm and alarm reset)
Frequency Setting	Keypad operation: INC (UP) or DEC (DOWN) keys Built-in or external potentiometer of 1 to 5 k ohm Analog input: 0 to 5 VDC, 0 to 10 VDC (Resistance = 22 k ohm) 4 to 20 mA DC Multistep frequency: Up to 4 different frequencies can be selected using ÖÖ input terminals Modbus RTU Option
Indication	Running: Digital indication of output frequency or output current (3-digit LED) Tripped: Cause of trip by code (3-digit LED)

Standard Specifications (Continued)

Acceleration/Deceleration Time	0.1 to 60.0 sec. (independently adjustable acceleration and deceleration)
Voltage/Frequency (V/F) Characteristics	Adjustable maximum frequency and base frequency
PID Control	PID control function is provided as a standard feature
Gain (frequency setting signal)	5 VDC or 10 VDC gain can be selected
Restart After Momentary Power Failure	Drive restarts without causing the motor to stop if the automatic restart is specified for the drive
Frequency Limiter	High and low limits can be set for the output frequency between 0 to 100% in Hz
Bias Frequency	The bias frequency can be set from -100 to +100% Hz
Frequency Jump Control	Jump frequency (3 points) and jump hysteresis width (1 point) can be preset
Torque Boost	32-step selectable
Starting Torque	150% or more at 6 Hz

Protection

Overload	Detects overload to stop drive
Instantaneous Overcurrent	Detect overcurrent due to overload on the drive output side to protect drive. Protects drive in case of ground fault (when starting) and short circuit of output circuit.
Overvoltage	Detects DC link circuit overvoltage to stop drive
Overheating	Detects abnormal temperature of cooling fin to stop drive
Motor Protection	Electronic thermal overload detector
Alarm Output	Outputs a relay contact signal when any protective function is activated (SPDT contact, 250 VAC, 0.3 A, cos = 0.3)

Options

Standard	DIN-Rail mounting kit
Communications	Modbus RTU

Mounting Space

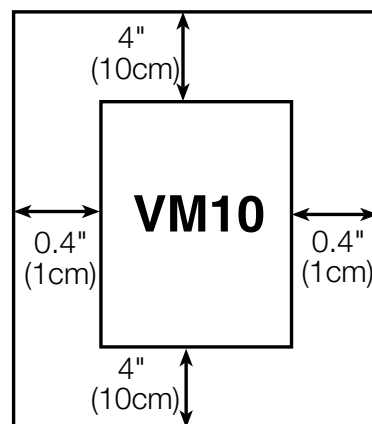

Dimensions

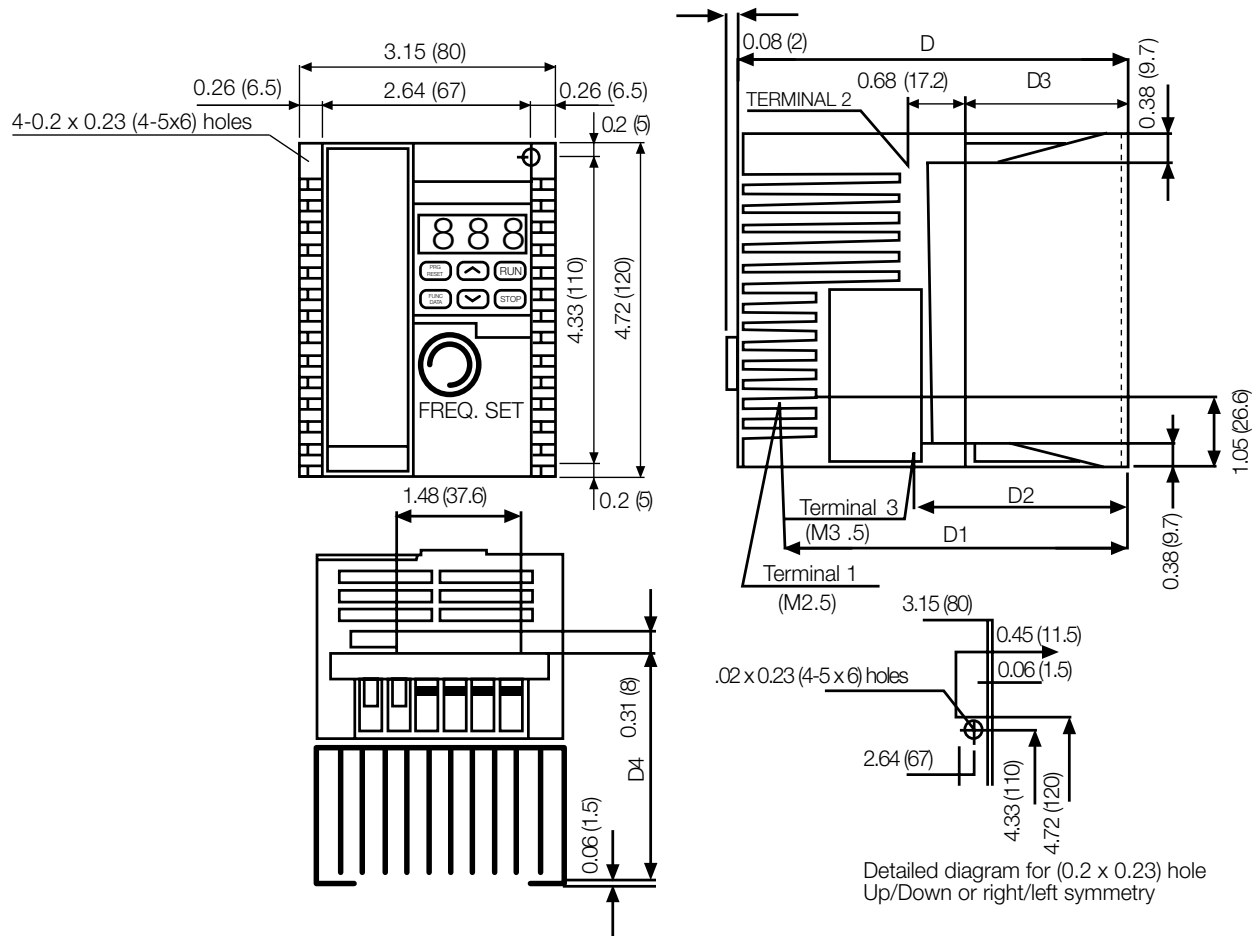

1

Three Phase

PART NUMBER	RATED CURRENT [A]	EXTERNAL DIMENSIONS (INCHES)				
		D	D1	D2	D3	D4
VM102F50-9	2.5	3.74	3.29	1.66	0.98	2.29
VM102001-9	4.0	4.72	4.27	2.65	1.97	3.28

Dimensions

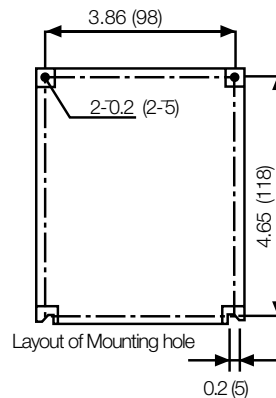
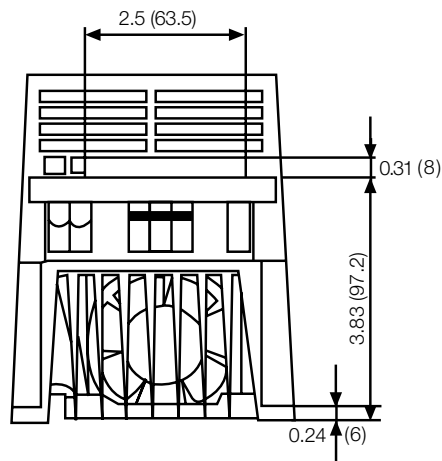
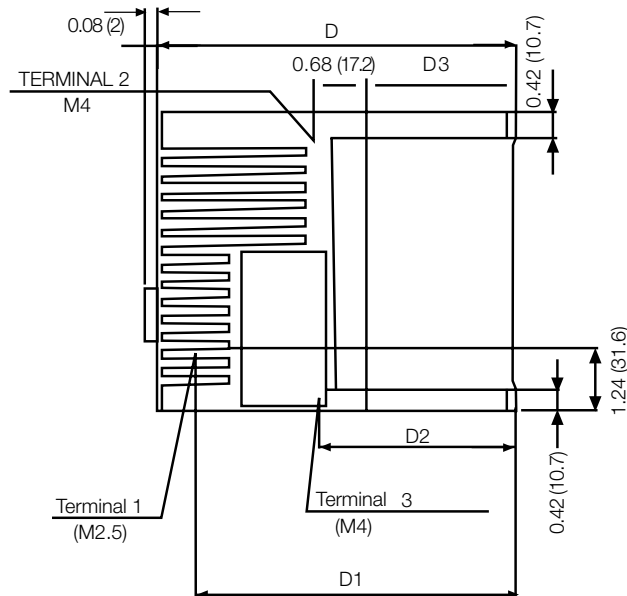
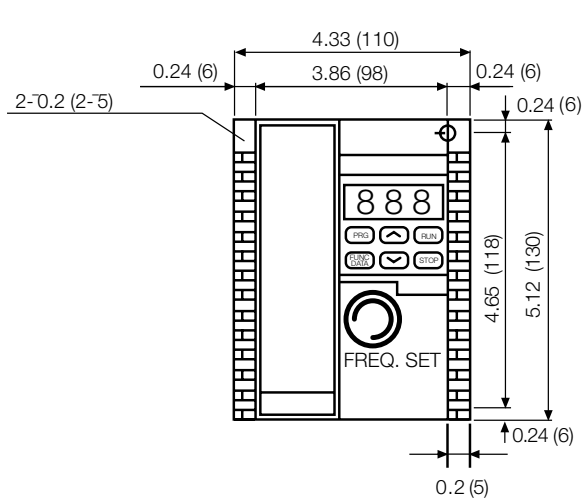

Three Phase

PART NUMBER	RATED CURRENT [A]	EXTERNAL DIMENSIONS (INCHES)				
		D	D1	D2	D3	D4
VM102002-9	7.0	5.47	5.02	3.20	2.52	
VM102003-9	10.0	5.47	5.02	3.20	2.52	

Dimensions

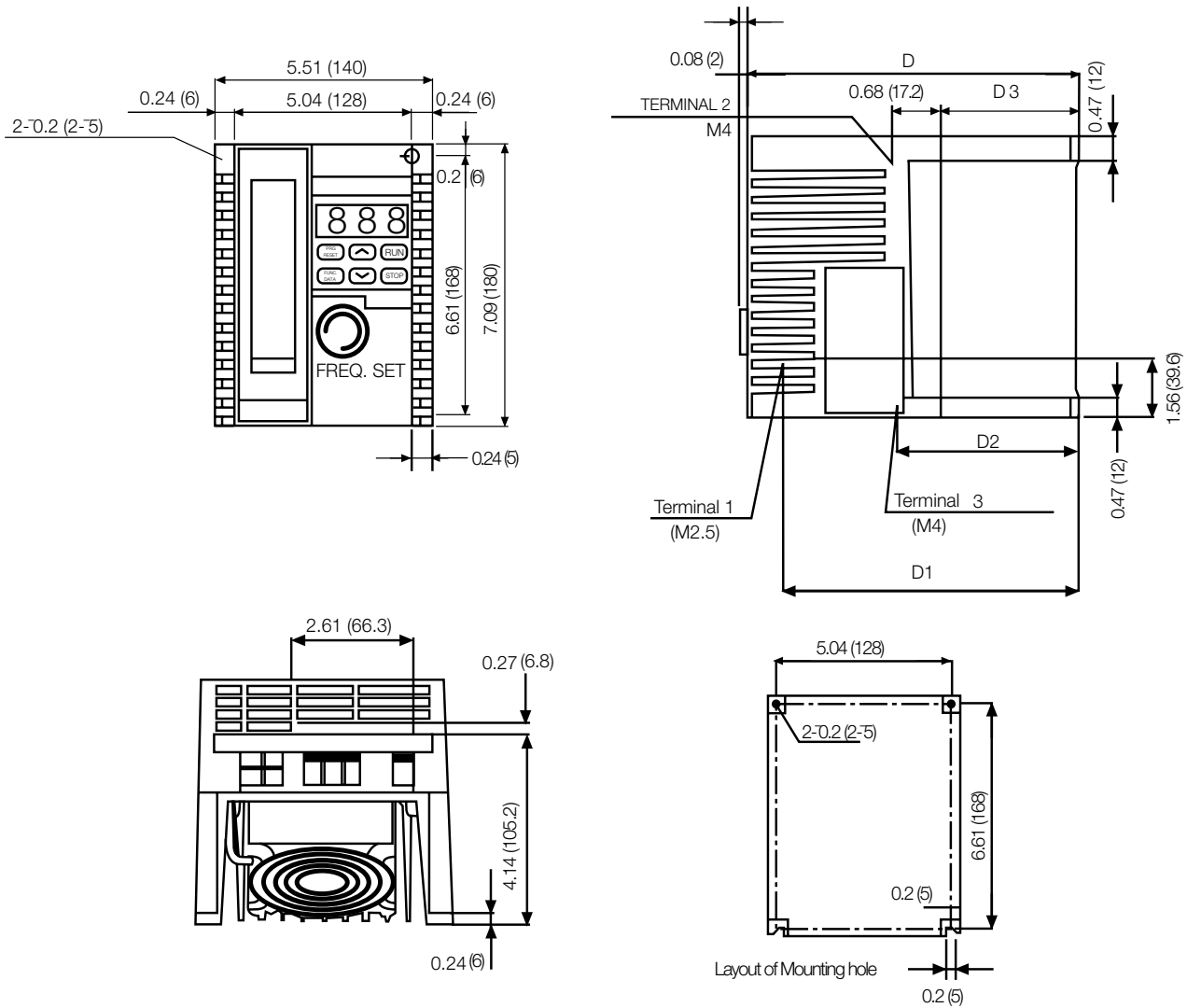

Three Phase

PART NUMBER	RATED CURRENT [A]	EXTERNAL DIMENSIONS (INCHES)				
		D	D1	D2	D3	D4
VM102005-9	16.5	5.39	4.94	3.51	2.83	



Basic Wiring Diagrams - Keypad Operation

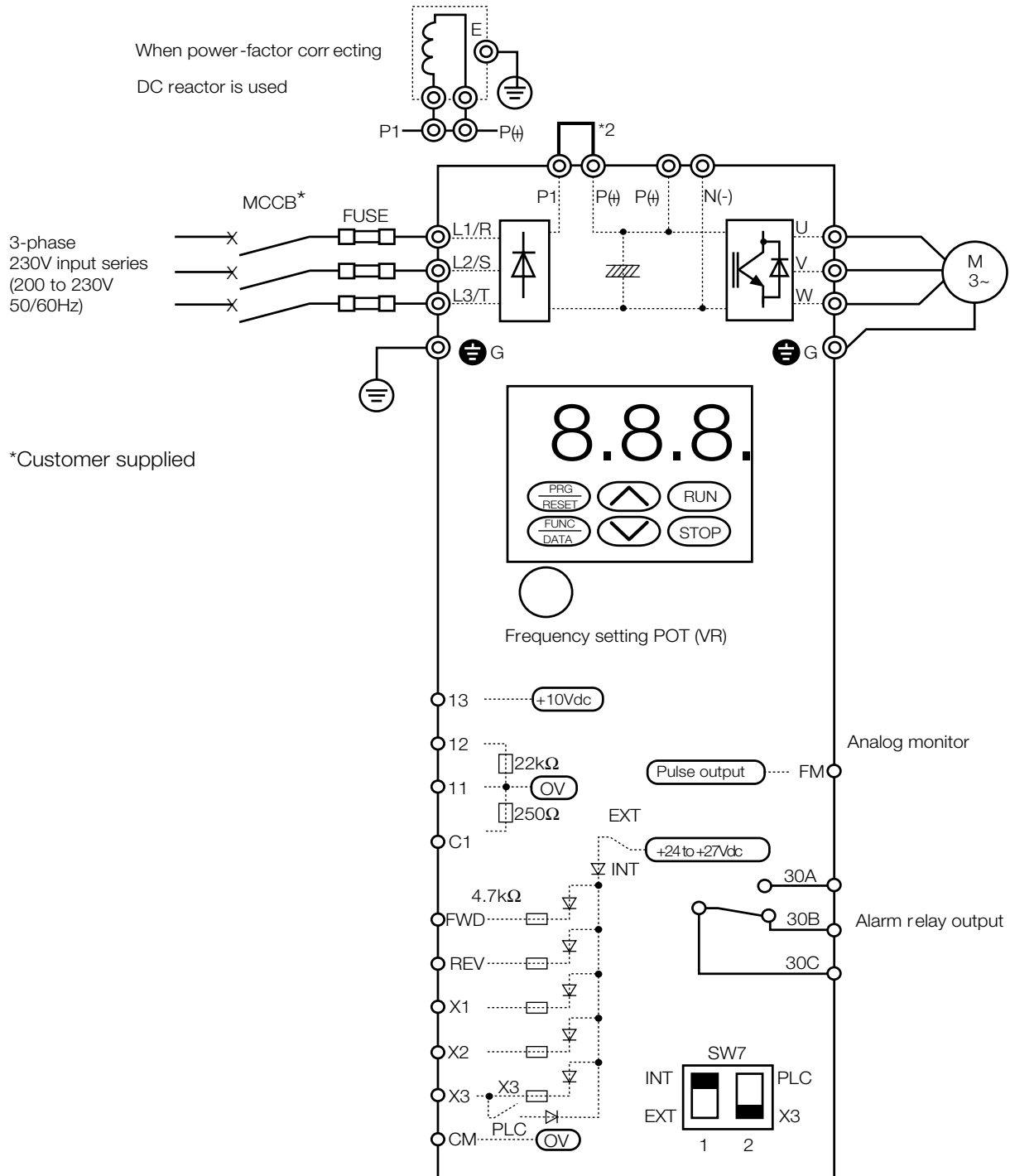

- 1) The RUN and STOP keys on the keypad panel can be used to start and stop the drive. The frequency setting, POT (VR) can be used to set the running frequency. Forward rotation is the default setting.
- 2) Remove the jumper between the P1 and P(+) terminals before connecting a DC reactor when required.
- 3) Connect the surge absorber snubber circuits in parallel with coils (such as magnetic contactors and solenoids) located near the drive.

Basic Wiring Diagrams - External Signal Operation

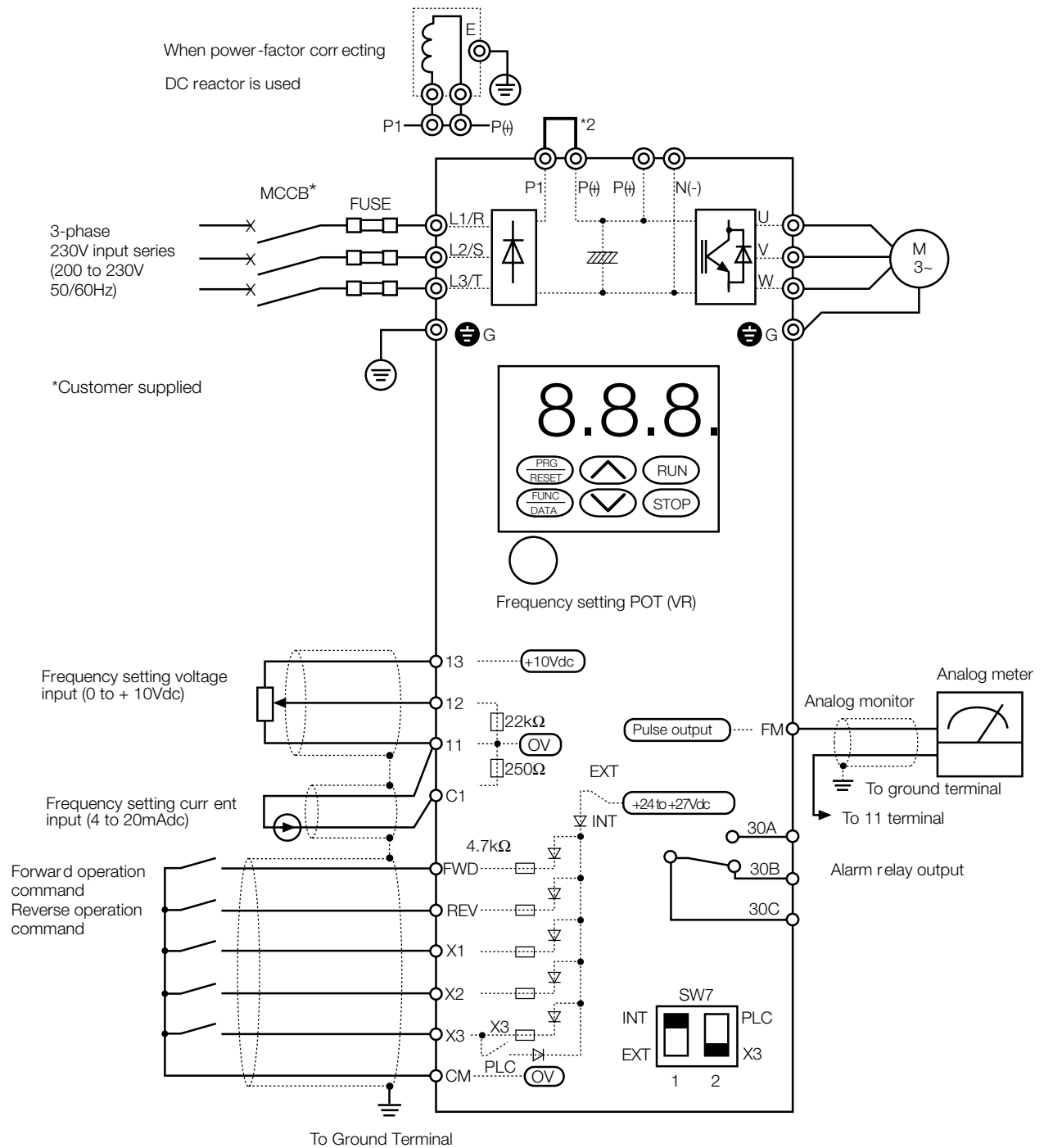

- 1) Use this connection to start, stop and set the running frequency with external signals. 0 to +10 VDC can be used when function F01 is set to 1 and 4 to 40mA can be used when function F01 is set to 2.
- 2) Remove the jumper between the P1 and P(+) terminals before connecting a DC reactor when required.
- 3) Connect the surge absorber snubber circuits in parallel to coils (such as magnetic contactors and solenoids) located near the drive.
- 4) Use twisted or shielded wire for control signals. Connect the shield to the ground terminal.