

VG5

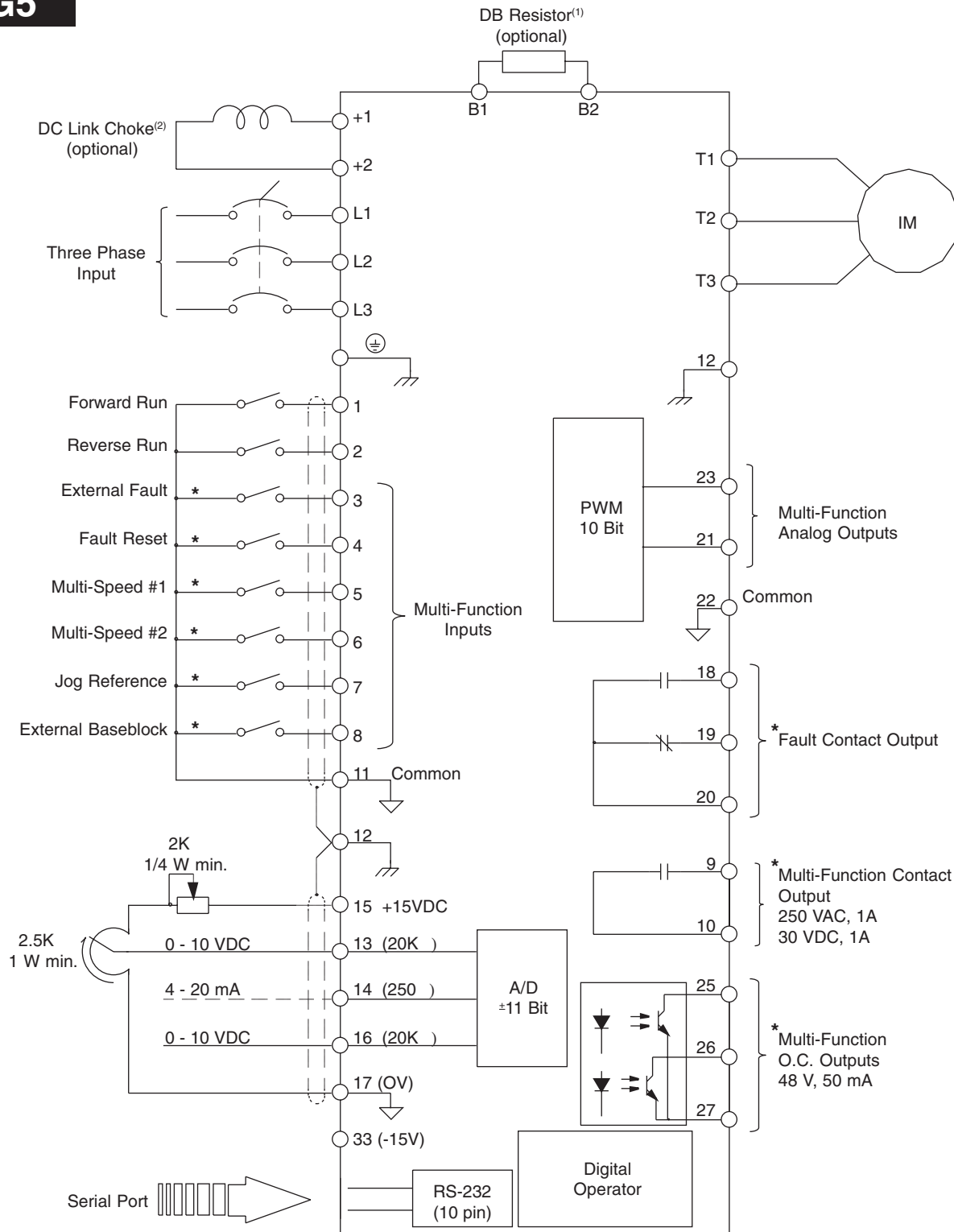

VG5

* Programmable Input/Output Functions. Factory defaults shown.

- (1) Internal dynamic braking electronics on 0.5 HP - 10 HP (230V), 1.0 HP to 25 HP (460V), and 2.0 to 25 HP (575V) models only. External DB electronics option required for higher horsepower models.
- (2) Input DC link reactor is standard on 30 HP to 750 HP (460V) models, and optional for models under 30 HP.