



User Guide

Flying Shear



Software for
Unidrive Classic

Part Number: 0460-0078

Issue Number: 6

Safety Information

Persons supervising and performing the electrical installation or maintenance of a Drive and/or an external Option Unit must be suitably qualified and competent in these duties. They should be given the opportunity to study and if necessary to discuss this User Guide before work is started.

The voltages present in the Drive and external Option Units are capable of inflicting a severe electric shock and may be lethal. The Stop function of the Drive does not remove dangerous voltages from the terminals of the Drive and external Option Unit. Mains supplies should be removed before any servicing work is performed.

The installation instructions should be adhered to. Any questions or doubt should be referred to the supplier of the equipment. It is the responsibility of the owner or user to ensure that the installation of the Drive and external Option Unit, and the way in which they are operated and maintained complies with the requirements of the Health and Safety at Work Act in the United Kingdom and applicable legislation and regulations and codes of practice in the UK or elsewhere.

The Drive software may incorporate an optional Auto-start facility. In order to prevent the risk of injury to personnel working on or near the motor or its driven equipment and to prevent potential damage to equipment, users and operators, all necessary precautions must be taken if operating the Drive in this mode.

The Stop and Start inputs of the Drive should not be relied upon to ensure safety of personnel. If a safety hazard could exist from unexpected starting of the Drive, an interlock should be installed to prevent the motor being inadvertently started.

General Information

The manufacturer accepts no liability for any consequences resulting from inappropriate, negligent or incorrect installation or adjustment of the optional operating parameters of the equipment or from mismatching the variable speed drive (Drive) with the motor.

The contents of this guide are believed to be correct at the time of printing. In the interests of a commitment to a policy of continuous development and improvement, the manufacturer reserves the right to change the specification of the product or its performance, or the contents of this guide, without notice.

All rights reserved. No parts of this guide may be reproduced or transmitted in any form or by any means, electrical or mechanical including photocopying, recording or by an information storage or retrieval system, without permission in writing from the publisher.

Copyright © 9 October 2006 Control Techniques Drives Ltd

Issue Code: 6

Firmware: V03.00.06

1	Introduction	6
1.1	Who Should Read This Manual?	6
1.2	Application Overview	6
1.3	Features	7
2	Mechanical Installation	8
2.1	Application Module & Unidrive	8
2.1.1	Application Module	8
2.1.2	Second encoder / resolver / SinCos Module	9
3	Electrical Installation	10
3.1	Unidrive	10
3.1.1	Control	10
3.2	Unidrive Power / Motor Connections	11
3.3	UTIM Signal Interface Unit	11
3.4	Connector Location	11
3.4.1	Unidrive Control Terminal Connections	11
3.4.2	UD70 Connections	12
3.4.3	Small Option Module	12
3.4.4	Interface module	13
3.5	Default Control Connections	13
3.5.1	Control Connections	13
3.5.2	Limit Switch Inputs	14
3.5.3	Hardwired Interface Connections	14
3.5.4	Registration Sensor Connections	15
3.5.5	Tool Control Connections	15
3.5.6	Connecting to a remote device using RS485 Comms	16
3.5.7	Monitoring	16
3.6	I/O Mappings	17
3.7	Isolation and Suppression	18
4	Software Installation	19
5	Getting Started	20
5.1	Unidrive	20
5.2	Operating Modes	20
5.2.1	Parallel Flying Shear	20
5.2.2	Angled Flying Shear	21
5.3	Scaling	22
5.3.1	Selecting suitable units	22
5.3.2	Example Scaling Calculations	23
5.3.3	SinCos Encoder Application Notes	24
5.4	Resolution And Accuracy	25
5.5	Commissioning Sequence	26
5.6	Application Set-up Parameters	34

6	Functional Description	40
6.1	Overview	40
6.2	Jogging & Positioning	40
6.3	Homing / Datuming	41
6.4	Registration	43
6.5	Flying Shear Profile Calculation	46
6.6	Cam Control And Virtual Master Control	51
6.7	Gap Profile Generator	52
6.8	Tool Control	54
6.8.1	Cutter Modes	55
6.8.2	Real Time Cut	55
6.8.3	Start Cut Mode	55
6.8.4	Manual Cut / Scrap Cut	55
6.8.5	Firing the tool at a specific position	56
6.9	Reference Selection and PID	58
6.9.1	Tuning Procedure	58
6.10	Hardware and Software Limits / Positions	61
6.10.1	Hardware Limits	64
6.10.2	Software Limits	64
6.11	Communications Watchdog	65
6.12	Fault Handling	65
6.13	Start / Stop Logic	67
6.14	Interlocks	68
6.15	Batch and Master Control	69
6.15.1	Batch control	69
6.15.2	Master Control	69
7	Parameter Descriptions	71
7.1	Relevant Unidrive Parameters	71
7.1.1	Parameters set by software on power-up	71
7.1.2	Parameters set by software Permanently	71
7.1.3	Drive Parameters set after a default (18.44 = 1)	72
7.1.4	Menu 18	74
7.1.5	Menu 19	85
7.1.6	Menu 20	95
7.1.7	PLC Registers	102
8	Error Handling / Trouble Shooting	103
8.1	Application Error Handling	103
8.1.1	Trip Codes	105
8.1.2	Drive Trip Recovery	106

9	Advanced Features	107
9.1	Serial Communications / Fieldbus Control	107
9.1.1	Control Word	_S70% (Parameter 73.70) 107
9.1.2	Fault Word	_R69% (Parameter 72.69) 109
9.1.3	Status Words _R70%, _R71%	109
9.2	Software Version	111
9.3	Mechanical Installation	111
9.4	Electrical Installation	112
9.4.1	CTIU110 Rear View	112
9.4.2	Serial Communications Cable Connections	113
9.5	Unidrive set-up	114
9.5.1	CTIU110 Configuration of the RS-485 Port	114
9.6	Operation Button Selection Actions	115
9.7	Navigation	115
9.7.1	Parent Menu Pages Navigation	116
9.7.2	Sub Menu Pages Navigation	117
9.8	Operators Screens Description	117
9.8.1	Top Level Screen and Functionality	118
9.8.2	Diagnostic Screens	118
9.9	Access	124
9.10	Splash Screens	124
9.10.1	Application Page (1st Page)	124
9.10.2	Software Version Page (2nd Page)	124
9.11	Parameter Save	125
9.11.1	Parameter Save Main Screen	125
9.11.2	Parameter Save Acknowledgement Screen	125
9.12	Trip & Alarm indication	126
9.12.1	TRIP Page (Alarm page 1)	126
9.12.2	ALARM Page (Alarm page 2)	126
9.13	CTIU Function Keys Allocation	127
9.13.1	Global Control Function Keys	127
9.13.2	Local Function Keys	127
10	Quick Reference	128
10.1	Application Parameters - Menu 18, Menu 19 and Menu 20	129
10.1.1	Menu 18	129
10.1.2	Menu 19	131
10.1.3	Menu 20	132
11	Documentation Reference	133
12	Signal Interface Unit	134
12.1	U.T.I.M.	134
12.2	U.T.I.M. 2	137
12.2.1	Logic Diagram	137
12.2.2	Electrical Installation	138
12.2.3	Technical Specification	139
12.2.4	Cable Specification	139

1 Introduction

1.1 Who Should Read This Manual?

This manual is intended to assist the engineer in commissioning the application software, and should be read in conjunction with the documentation that is supplied with the drive and other associated hardware. The safety systems that are required to prevent risk of injury to persons operating or maintaining the machine are not discussed in this manual. The engineer must be familiar with and able to implement the required safety systems. This manual assumes that the engineer is familiar with relevant Control Techniques products and understands the requirements for the application.

If you do not feel confident of the above, then you should contact your local Control Techniques drive centre or distributor to obtain service / advice.

1.2 Application Overview

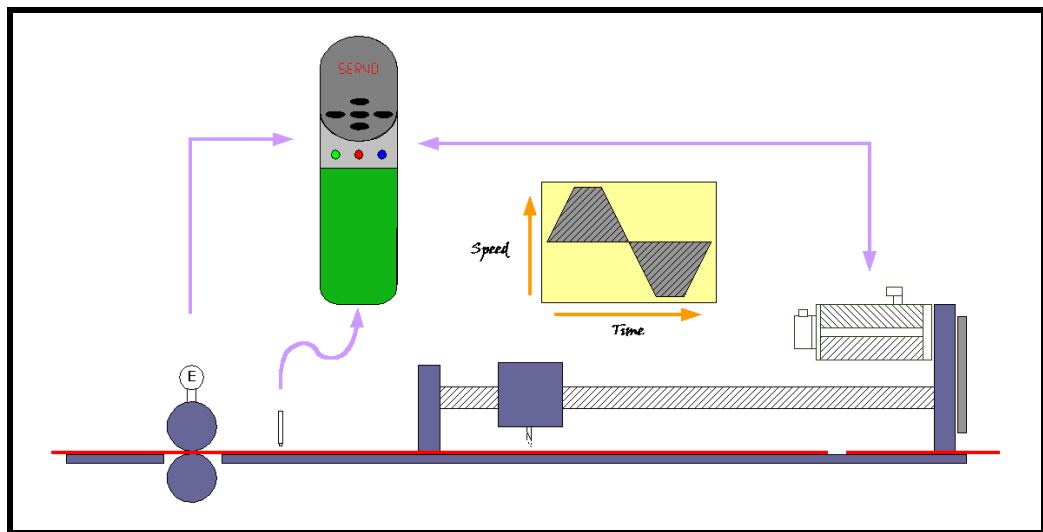

The Flying Shear is a common industrial application for cutting a product into smaller lengths, without stopping the line, this means that the main production process is not interrupted, and so machine productivity is maximised.

The cutting tool is typically mounted on a carriage that moves either parallel to the product flow or at an angle across the product flow. The flying shear drive accelerates the carriage to synchronise with the line speed, while synchronised the cut is done and the carriage then decelerates and returns to its original position ready to cut again. There are also many other similar applications where a carriage must be synchronised at line speed and most of these can also be accommodated using the flying shear application software.

The drive is configured using real engineering units of choice such as mm or inches. This means that the configuration of the system is made very easy, through an operator interface or by entering configuration parameters directly on the drive.

The forward profile is optimised for each application by breaking the synchronised, part of the profile down into three areas: settling time, cut time and tool rise time, these are entered in milliseconds. The drive will then calculate the profile and perform checks to ensure that the parameters entered are achievable, given the length of motion available, and also the required cut length.

Typical applications include various types of cut to length machines, depositors, punches, product inspection, or any other process where synchronisation at line speed is required.

A couple of possible applications are:

A machine extrudes plastic pipes that must be supplied to the customer in pre-cut lengths. The extrusion process requires the extruder to run at a continuous speed to maintain the quality of the product. The pipe is uniform along its length and provided the length is within a set tolerance then the pipe is fit for sale. The flying shear is used to cut the product cyclically.

The end product is a steel carton. In the first part of the process the steel is printed and must then be punched using a registration mark printed on the product. The flying shear is used to detect a mark and accurately synchronise the shear with reference to the mark.

1.3 Features

- Hardware and software limits.
- Fieldbus interfaces are available: CT-Net, Profibus, Devicenet, Interbus-S, Modbus plus, Can-Open and RS485.
- Manual functions are available such as Jogging.
- High-speed output can be used to fire the cutting tool.
- Registration can be used to initiate the cut.
- Batch counter.
- The motion profile may be changed during operation such as cut lengths, acceleration etc.
- Real engineering units are used.
- Units are defined for the master and slave axis, as the number of encoder counts per unit. The units are entered as a numerator and denominator to allow high-resolution fractional values.
- Resolution of the cut-length may be entered to within 0.001 units.
- Profile optimisation reduces the machines mechanical stress: The return profile is calculated to operate at the slowest speed and acceleration rate, and yet with sufficient time to achieve the next cut, either triangular or trapezoidal profiles are used.
- MMI support.
- Gap Control - a typical requirement for log cutting applications.
- Parallel or angled Shear.
- Registration, with or without windowing.

2 Mechanical Installation

NOTE Ensure the Unidrive is correctly installed in accordance to the Unidrive Installation Manual

2.1 Application Module & Unidrive

- Isolate the Drive from the main supply and allow 5 minutes for the DC Bus capacitors to discharge.
- Insert the UD70 Application Module as shown below. Ensure that it is correctly inserted. The module will click firmly into place.
- The Unidrive must be disconnected from the mains supply before installing or removing an option module.

2.1.1 Application Module

- To remove the module, pull on the black tab, and the module will disengage from the connector and pull out of the Drive.

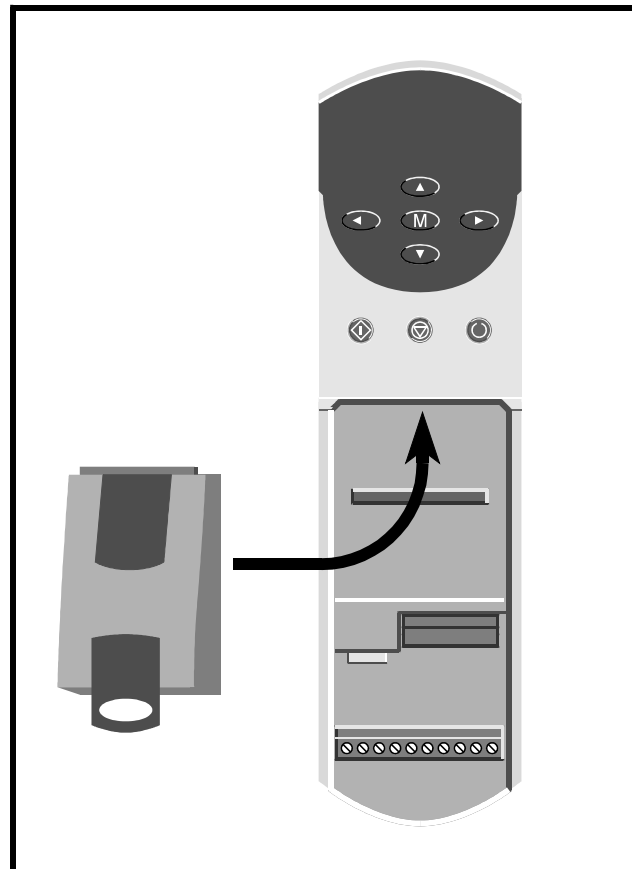

NOTE Ensure the Unidrive is correctly installed in accordance to the Unidrive Installation Manual

2.1.2 Second encoder / resolver / SinCos Module

- The small option module connects to the Unidrive via a simple press fit connector.

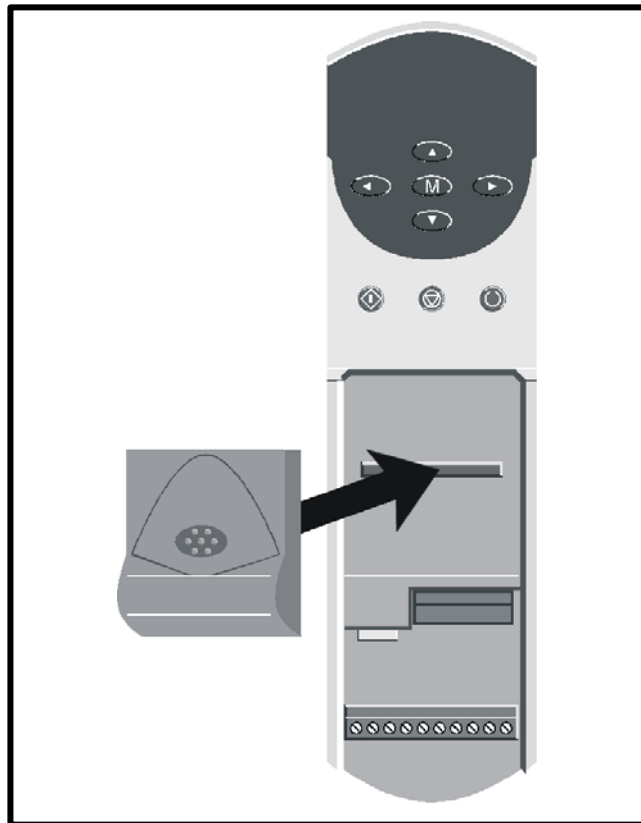

3 Electrical Installation

3.1 Unidrive

3.1.1 Control

+24V digital supply (Terminal 22)

Supply for external digital signal devices.

Voltage Tolerance:	±10%
Nominal output current:	200mA
Overload output current:	240mA (including Digital Outputs)
Protection:	Current fold-back above 240mA

+10V analog supply (Terminal 4)

Supply for external analog signal devices

Voltage Tolerance:	±1%
Nominal output current:	10mA
Protection:	Current limit and thermal trip

Digital Outputs

Type of output:	Negative logic digital (push-pull)
Voltage range:	0V to +24V
Max. output current:	200mA
Overload output current:	240mA (including +24V Supply)
Update Time: (info...)	5.5ms / 7.4ms

Digital Inputs

Type of input:	* Negative logic digital
Voltage range:	0V to +24V
Absolute max. Voltage range:	-3V to +30V
Input current when +24V applied:	3.2mA
Logic levels:	Logic high: >+15V Logic low: < +5V
Sample Time: (info...)	5.5ms / 7.4ms

* Drives with firmware V2.10.4 and later allow the selection of either negative logic or positive logic on the inputs. Selection is made with parameter 08.27.

Analog Outputs

Type of output:	Single-ended analog - bipolar
Max. output voltage:	-10V to +10V
Max. output current:	10mA peak
Load resistance:	1kΩ minimum
Protection:	Short-circuit proof
Resolution:	10-bit plus sign
Update period: (info...)	5.5ms / 7.4ms

NOTE

Whilst running the flying shear software, the only sample / update time available is 7.4ms, as the switching frequency is limited to 4.5kHz and 9kHz. See the Unidrive user guide for further details.

3.2 Unidrive Power / Motor Connections

Please refer to the Unidrive documentation for the relevant information regarding:

- Voltage Rating
- Current rating
- Motor Connections
- Encoder / Resolver Connections

3.3 UTIM Signal Interface Unit

The U.T.I.M. (Universal Type-Interface Module) is a DIN rail mountable unit. It is designed to help the user by providing conversion between standard signal levels.

Refer to section *Signal Interface Unit* on page 134 for more detail.

3.4 Connector Location

3.4.1 Unidrive Control Terminal Connections

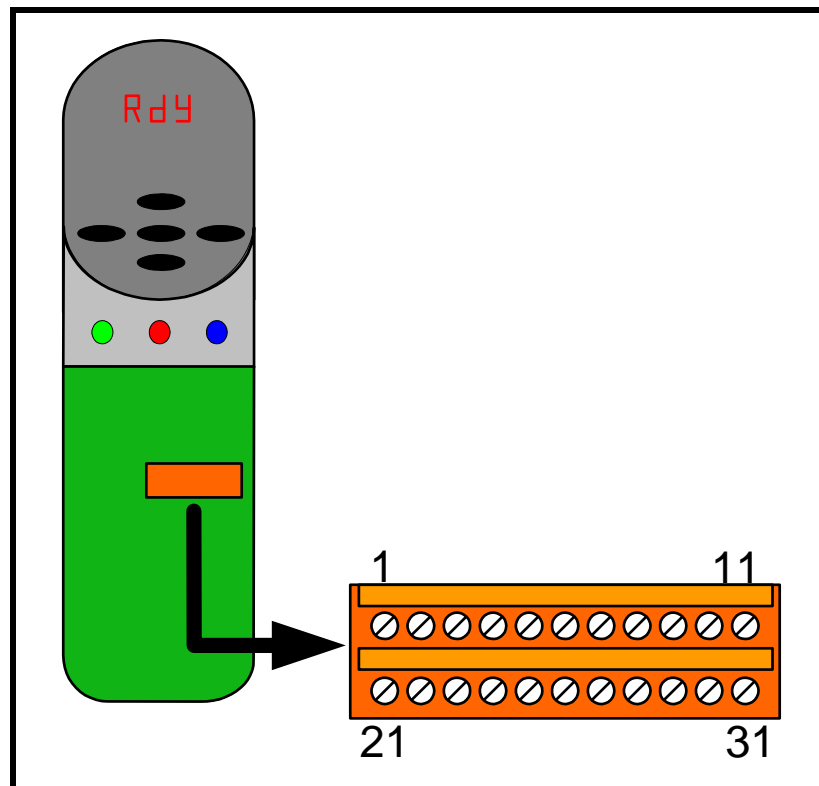

3.4.2 UD70 Connections

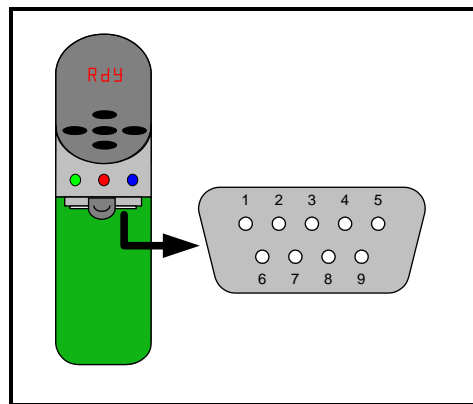
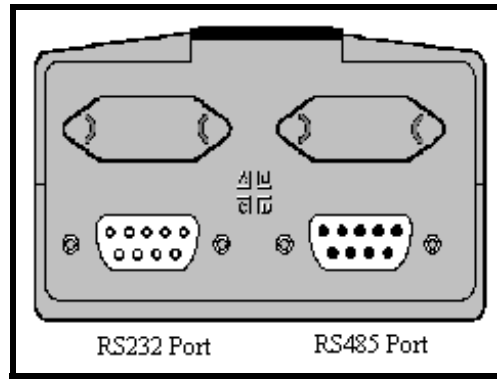

Pin Function

- 1 0V serial comms
- 2 /TXD
- 3 /RXD
- 4 Digital Input 0
- 5 Digital Input 1
- 6 TXD
- 7 RXD
- 8 Digital Output
- 9 0V Digital

3.4.3 Small Option Module

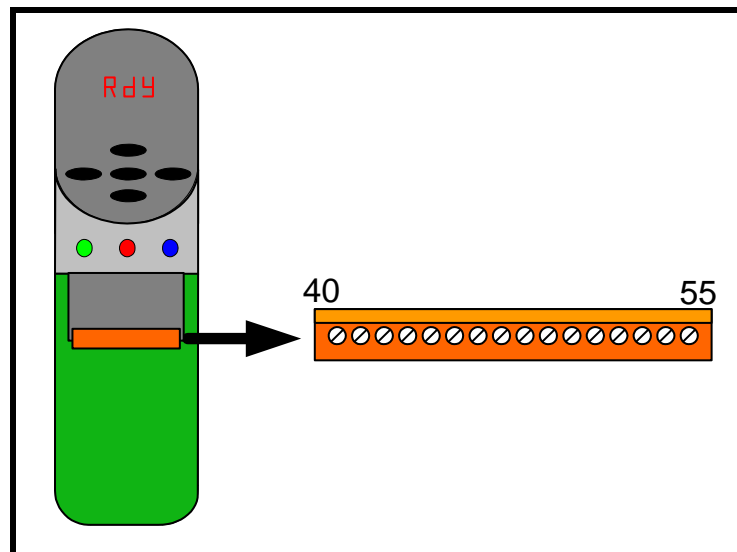

3.4.4 Interface module

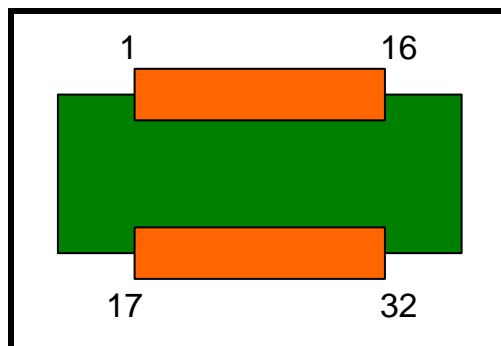

3.5 Default Control Connections

3.5.1 Control Connections

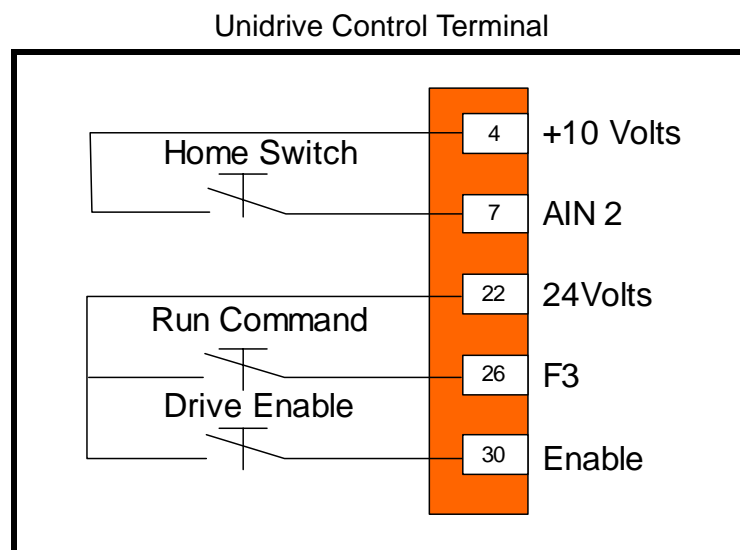

3.5.2 Limit Switch Inputs

Unidrive Control Terminal

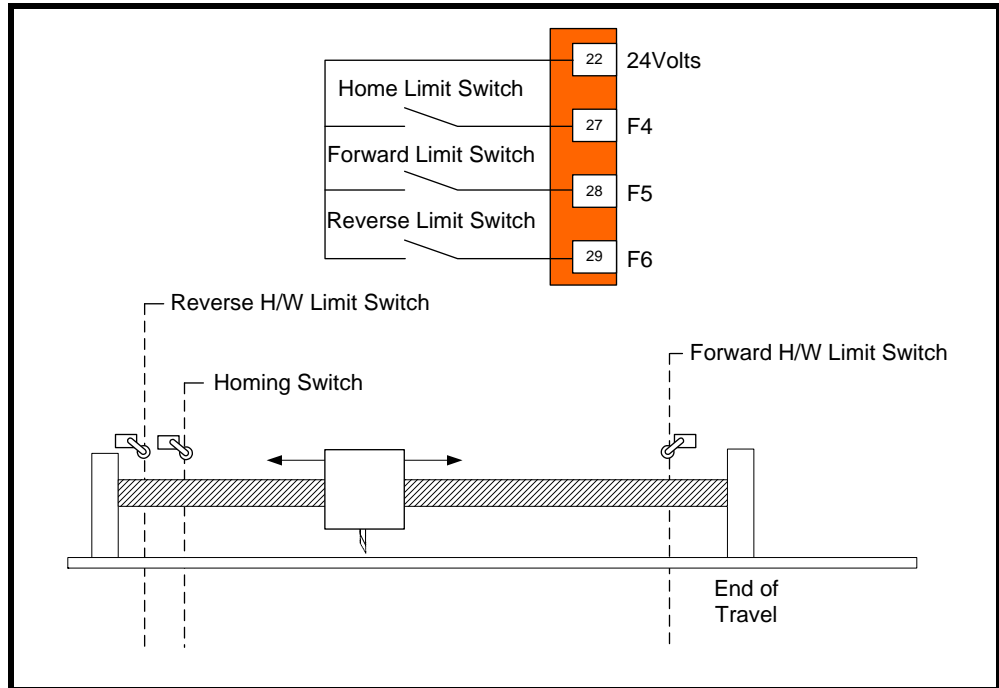

NOTE If a failure to stop would cause a risk of injury to personnel, then a hardware safety system should be used to ensure that the flying shear carriage would stop if the limits are passed.

3.5.3 Hardwired Interface Connections

Unidrive Control Terminal

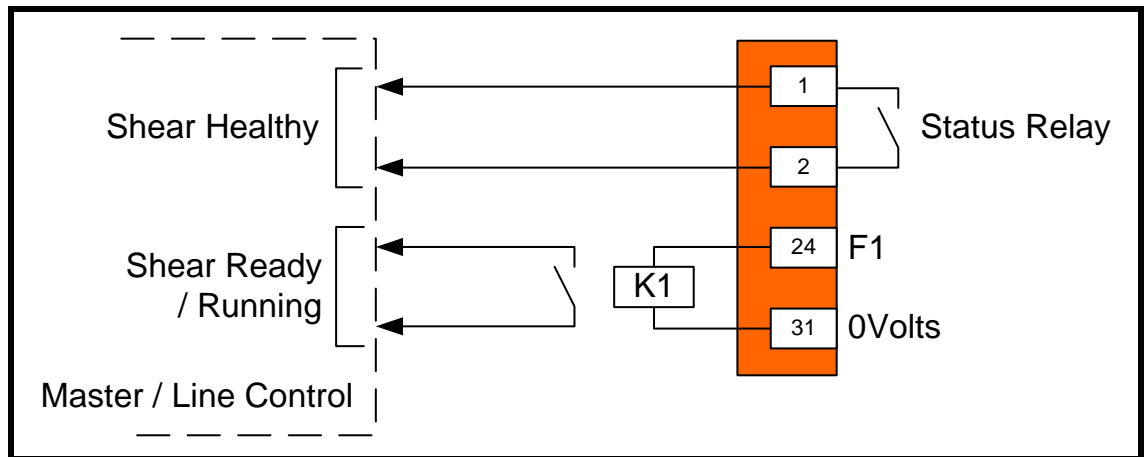

NOTE If you have chosen to use negative logic 8.27 = 0, then the shear ready relay above (K1) needs to be connected between terminals 24 and 22.

3.5.4 Registration Sensor Connections

Wiring for Second Encoder Module - UD51 Only.

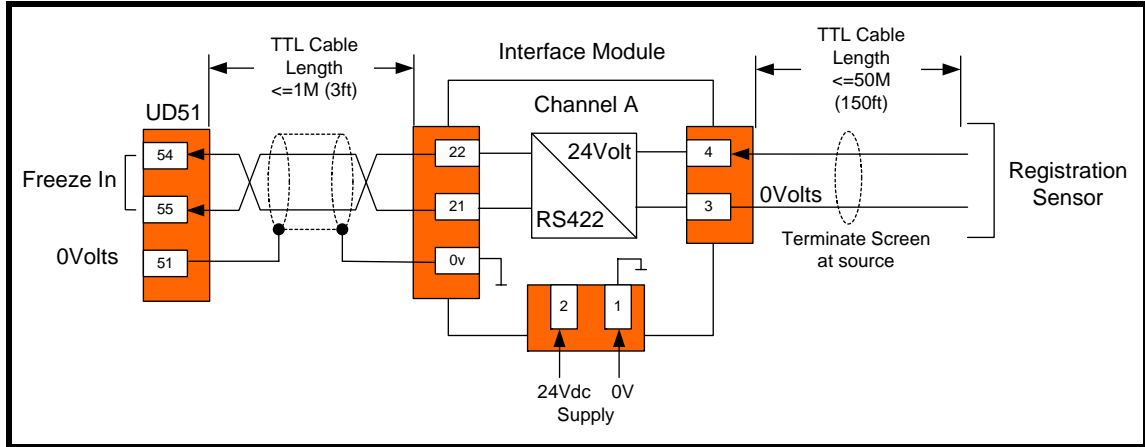

NOTE For Sin Cos Encoders the Freeze input is connected to pins 48, 49 and 52, which are Freeze, /Freeze and 0volts respectively.

NOTE Registration cannot be used if Resolver feedback is used as there is no Freeze input available on the UD53 Resolver option module.

3.5.5 Tool Control Connections

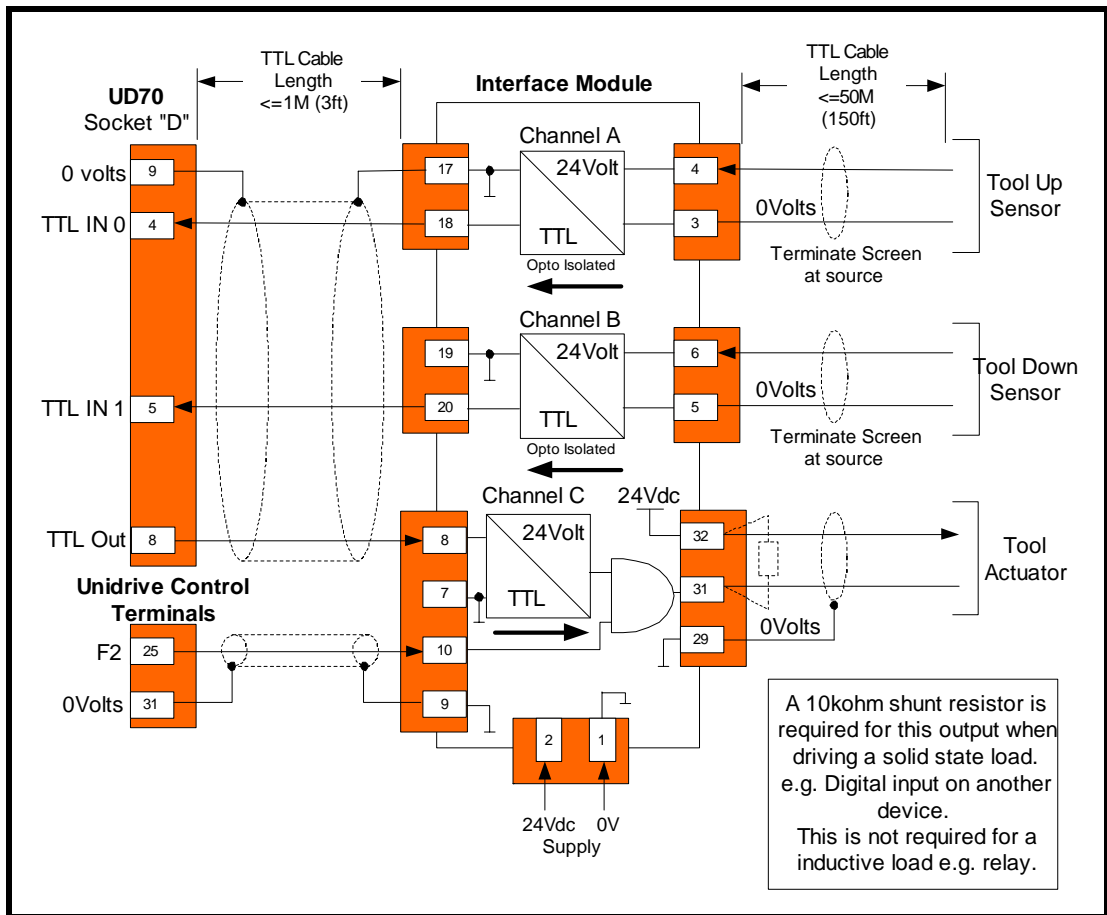

NOTE Tool up and down signal requirements are dependant on Cutter mode set in parameter 19.26. If the TTL input are used, then do not use parameters 19.46 and 19.48, both must be set at 0 for correct operation.

3.5.6 Connecting to a remote device using RS485 Comms

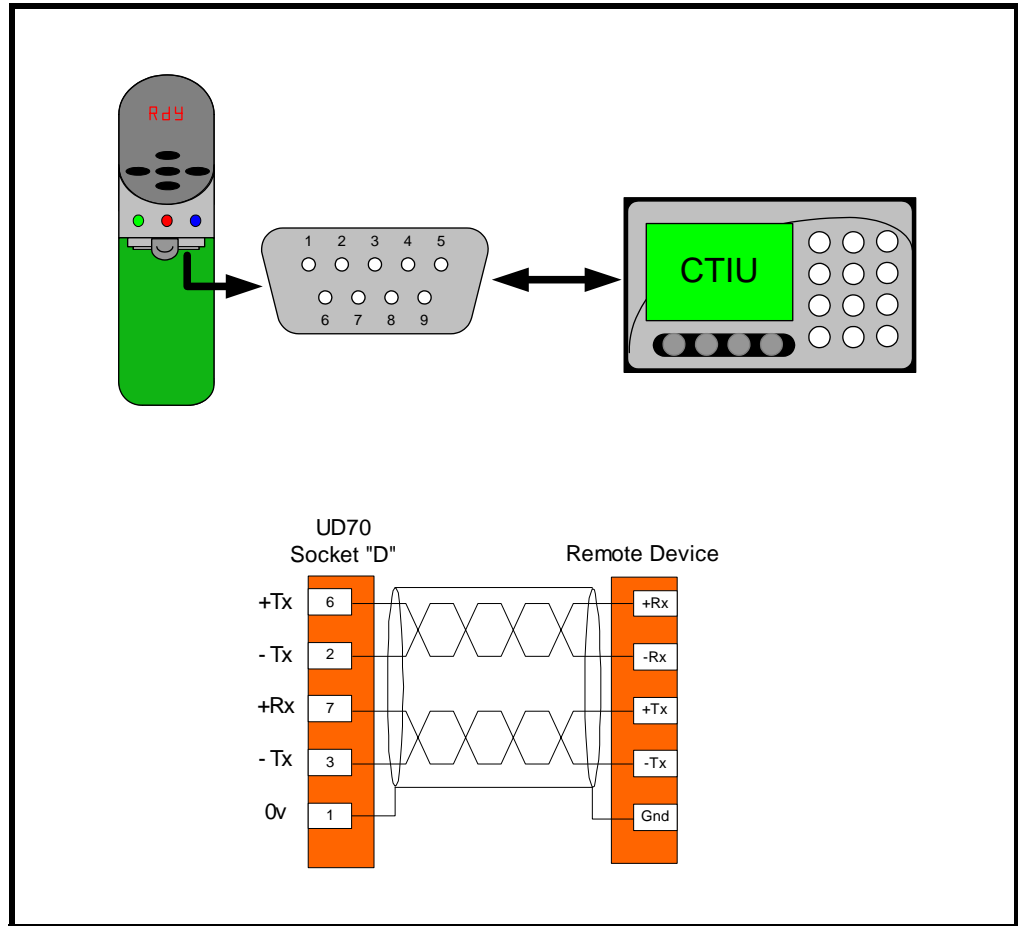

3.5.7 Monitoring

Unidrive Control Terminals

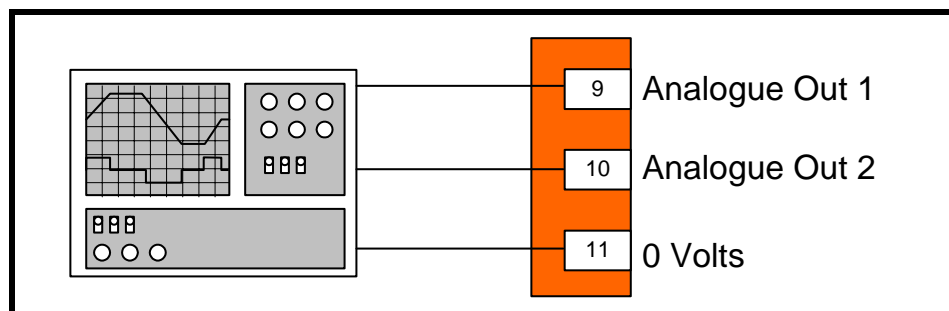

NOTE Analog output 1 and 2 are directed to parameters 3.02 (speed in rpm) and 4.02 (active current) respectively, from default. The Analog outputs may be directed to other parameters; refer to the Unidrive user guide for further details.

3.6 I/O Mappings

Setting parameter 18.44 to a 1 sets the default flying shear I/O mapping; 18.44 will immediately return to 0 after it is set to 1. Setting the normal Unidrive I/O mapping parameters to alternative locations can change the default configuration. After a default, the drive is set to positive logic, parameter 8.27 = 1.

Digital I/O

I/O Point	Description	Destination	Invert	In / Out Select
F1	Shear Ready	19.48	Off	Out
F2	Tool Enable	19.49	Off	Out
F3	Run Input	19.33	Off	In
F4	Home Switch	18.32	Off	In
F5	Fwd Limit	19.40	Off	In
F6	Rev Limit	19.41	Off	In

Analog I/O

Ain 1 / 3 are not used

Ain 2 is used to initiate a home sequence using programmable thresholds.

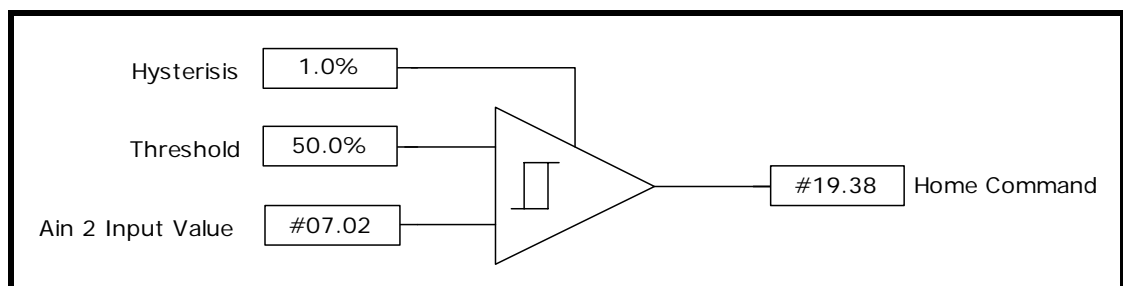

Programmable Threshold Settings

12.03 = 7.02

12.04 = 50.0

12.05 = 1.0

12.07 = 19.38

NOTE

If you do not want to initiate a homing sequence from analog input 2, then 12.07 should be set to 0.00.

UD70 TTL I/O

The UD70 IO is used because the update is very fast (virtually immediate), and it removes the need for additional external I/O, if you believe that your application does not require the fast update then you could decide to use the normal Unidrive I/O.

TTL In 0 – Tool Clear / Up, **or** write 1 to parameter 19.46

TTL in 1 – Tool Down, **or** write 1 to parameter 19.47

TTL Out – Tool Cut Signal, same as parameter 18.43

NOTE Tool up and down signal requirements are dependant on Cutter mode set in parameter 19.26. If the TTL input are used, then do not use parameters 19.46 and 19.48, both must be set at 0 for correct operation.

3.7 Isolation and Suppression

If the Digital inputs are to be switched from locations outside the control cabinet on long cables, relays with a separate power supply should be used to isolate the drive from harmful reflected or induced voltages.

4 Software Installation

There are two software files that are required to be installed within the Application module, and these are as follows: -

1. Application file- Fly.bin
2. System file - This is dependant on the application and fieldbus interface used. Version >= V03.00.02 should be used.

UD70OS.SYS -	UD70 Application module only
UD70NET.SYS -	UD70 and CTNet
IBSPROFI.SYS -	UD70 and Profibus-DP or Interbus
DNET.SYS -	UD70 and Devicenet
MBPLUS.SYS -	UD70 and Modbus-Plus
DPLCAN.SYS -	UD70 and CAN
CANOPEN.SYS -	UD70 and CANopen

The following parameters indicate the installed software version. '0' denotes no software file is installed.

Parameter	Description	Parameter Notation
17.02	System file version number	3.06 = V03.00.06
20.49	Application file version number	10200 = V01.02.00

To download the system and/or the application file to the application module the following items are required:

- A standard one to one serial cable connected between the PC serial port and the RS232 port on the application module, (Connector C).
- Control Techniques Windows™ 'WinFlasher' software. This software is on your Flying Shear CD ROM together with the software files.

5 Getting Started

5.1 Unidrive

1. Default all drive parameters (refer to the Unidrive user guide).
2. Refer to the Unidrive Getting Started Manual to commission the Unidrive before attempting to set up the Flying Shear Application.
3. If the UD70 is not new then check that the menu 20 parameters are zero, and erase the old program using WinFlasher.
4. Set parameter 17.13 = 1, so that the application programmes will run automatically on power-up.

NOTE Drive Switching Frequency is set at either 4.5 or 9Khz.
Position Loop Update = 1.84ms.
Speed loop update = 460us

5.2 Operating Modes

5.2.1 Parallel Flying Shear

With parallel flying shears, the carriage travels in the same direction as the material. In the example shown below a shear is used to cut through a material, while the carriage and the material are synchronised. The shear would then be raised and would return to the start position ready to repeat the Cycle. The parallel mode is best suited to applications where the tool operates instantaneously across the whole material width at the same time, such as a punch tool or a shear.

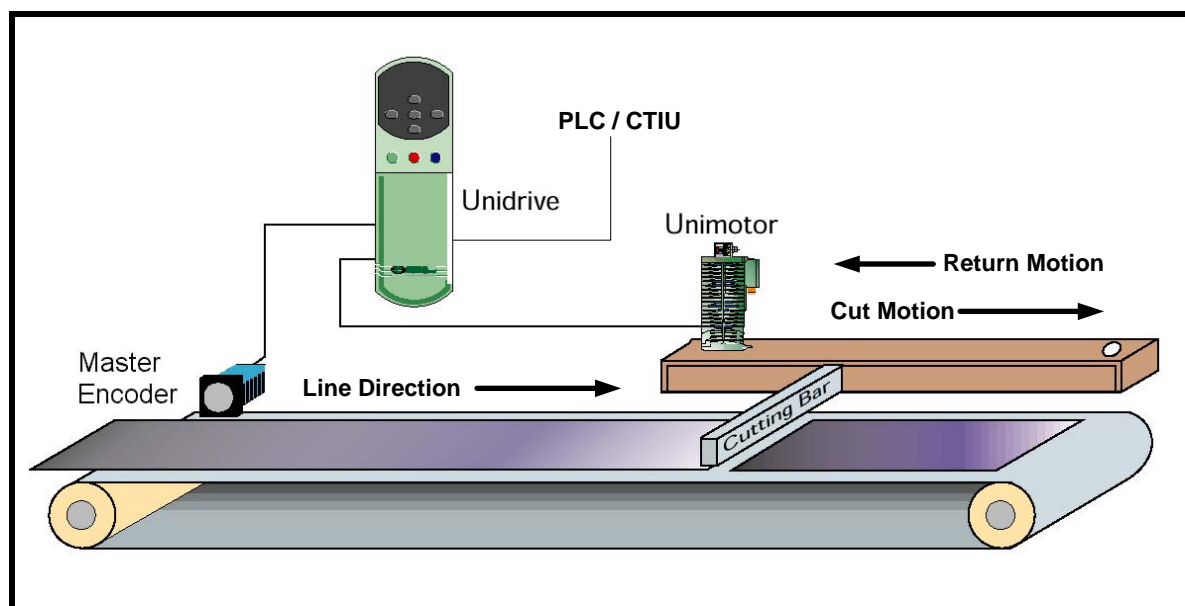

NOTE The shear profile is calculated based on the maximum master speed, and at lower master speeds than the maximum master velocity, the cut times 20.29, 20.30, 20.31 increase inversely proportional to the master speed e.g. with a maximum master velocity (20.28) of 100 units / second and a cut time (20.30) of 100ms at a master speed of half the maximum set in 20.28 the cut time will be 200ms or double. If your application requires that the cut time is constant regardless of the line speed (e.g. a bag sealing application), then parameter 18.50 can be set, which will keep the cut time 20.30 in real time.

5.2.2 Angled Flying Shear

With Angled Flying shears the saw travels across the material at an angle to the product flow, the speed that the saw carriage must travel depends upon the angle between the shear and the material flow. This mode is especially useful in applications such as a saw or a plasma-cutting tool where the tool must travel across the product at 90 degrees to the flow.

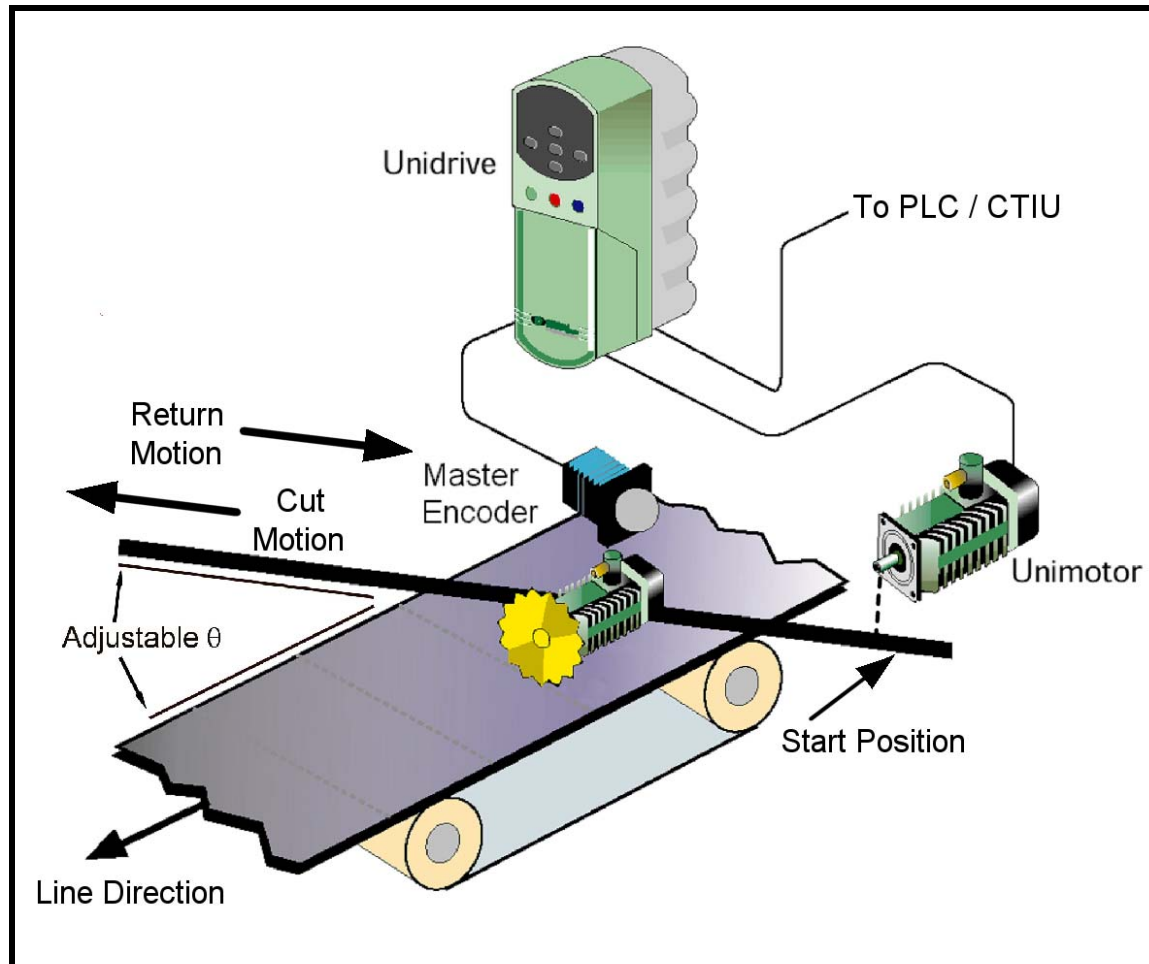

NOTE The Angled cut axis speed can be calculated from:

$$\text{Angled cut axis speed} = \text{Line Speed} / \text{Cos } \theta$$

5.3.2 Example Scaling Calculations

For this example we will select mm as our unit.

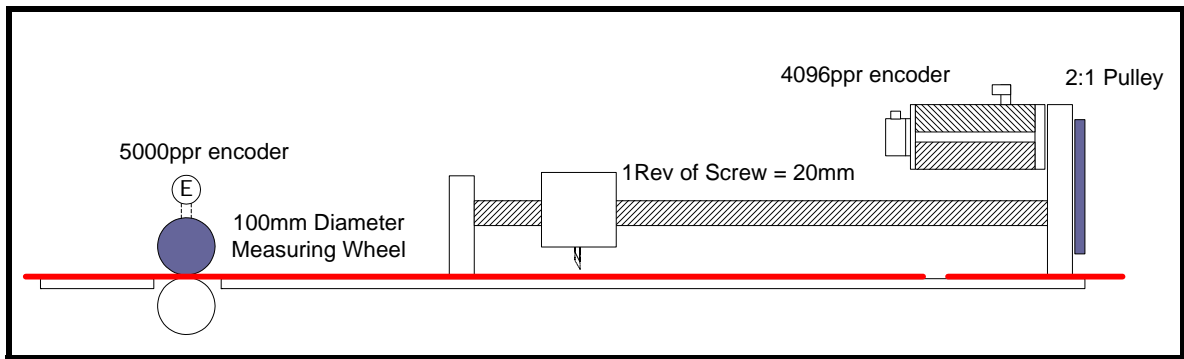

Master

The quadrature encoder will give the following resolution

$$4 * 5000 = 20000 \text{ counts / rev}$$

Circumference of the measuring wheel is

$$\text{PI} * 100\text{mm} = 314.16 \text{ mm}$$

The encoder counts per mm = $20000 / 314.16 = 63.66$

The numerator and denominator could be entered as:

Numerator = 6366 - enter value into parameter 18.13

Denominator = 100 - enter value into parameter 18.12

In cases where the base units are a lot smaller than the longest cut length, the resolution of the scaling will become more important to ensure cut accuracy is achieved, (with the required tolerance): e.g. units in millimetres, cut length in 10's of metres. In these cases the numerator resolution is restricted by the parameter range of 32000, therefore it is not advisable to use the base of 10 for the denominator, but to find the lowest common multiples for both the Numerator (counts) and the denominator (units).

To check the scaling is correct perform the following:

1. Cut the longest length required
2. Measure the length cut
3. If the cut length is not to the length set (+/- tolerance), then change the master scaling parameter/s as follows:

New scaling =

$$(18.13 / 18.12) * ((20.24 + 20.32) / \text{Actual measured length})$$

Slave

The encoder resolution is $4 * 4096 = 16384$ counts per revolution.

If the motor rotates 1 revolution, then the screw will travel 0.5 revs (2 :1 pulley), and the carriage will travel 10 mm.

Encoder counts per mm = $16384 / 10 = 1638.4$

The numerator and denominator could be entered as:

Numerator = 16384 - enter value into parameter 18.15

Denominator = 10 - enter value into parameter 18.14

If the value of the numerator is too large then the units must be changed, such as mm multiplied by 10 could be used.

NOTE In this example, the ratio between the master and the slave resolution is approximately a factor of 26 ($1638.4 / 63.66$), this means that during the time that the slave is synchronised to the master, when the master moves 1 count then the slave must move 26 counts, this is like an amplifier with a very high gain, and can produce some problems with noisy operation and instability. To prevent these problems, it is recommended to increase the resolution of the master so that it is similar to the resolution of the slave, this could be done by selecting a smaller measuring wheel diameter and / or increasing the encoder resolution or using SinCos encoder (Refer to section SinCos Encoder Application Notes).

Where it is not possible to fit a high resolution encoder, or if a system is retro-fitted re-using an old encoder, parameter 18.35 has been introduced which enables a 40ms filter which will help reduce motor noise caused by low resolution encoders. When the filter is enabled there will be a small positional following error, when the master accelerates or decelerates.

5.3.3 SinCos Encoder Application Notes

A SinCos encoder is a high-resolution feedback device, which can have the capability of feeding the absolute position via a RS485 connection on power up. The encoder can be supplied as single or multi-turn device. The Flying shear software does not accommodate for the absolute position on power up, therefore a home routine is always required to be performed.

Source Selection

The SinCos interface can be used as the Master or Slave (drive feedback also) positional feedback, this is selected by parameter 16.14 (0 = slave : 1 = Master).

Resolution

The resolution as default is interpolated from 2048 * PPR to 16384, (14bit) counts per revolution. This can be extend by setting parameter 71.19, (_Q19%) with the addition bit resolution required, up to a maximum of 22bit (based on a 512ppr encoder).

$$\text{Counts/rev} = 2^{14 + \text{parameter } 71.19}$$

e.g. for 20bit resolution set parameter 71.19 = 6

NOTE Parameter 71.19 can only be accessed via serial communications, (e.g. Using CT Browser, Sypt or CTIU).

To save and use the new resolution setting set parameter 17.19 = 1, (note this will automatically reset to zero on acknowledgment).

Simulated Encoder Output

When the Master axis is driven by a Unidrive fitted with a SinCos encoder, the master position can only be sourced to the slave by using the simulated encoder output on the SinCos interface, (SinCos encoders cannot be daisy chained like a normal incremental encoder). The simulated encoder output is equivalent to a quadrature encoder (not SinCos), and the resolution is equivalent to the SinCos PPR (with no interpolation).

Therefore with a 512PPR SinCos encoder the simulated output would also be 512PPR (2048counts per rev). Resulting in a much reduced & course resolution.

The SinCos encoder must be connected directly to the axis to benefit from the resolution this encoder can provide.

Set up

For more information on the SinCos encoder interface set up refer to the SinCos User Manual (0460-0085).

5.4 Resolution And Accuracy

Calculating the accuracy that is achievable from the flying shear depends upon many factors, and so is very difficult to calculate reliably, however, from experience we can make some assumptions and estimate the likely accuracy that we can realise.

If we assume that the mechanical system is well designed:

- The inertia mismatch between the load and motor is approximately 1:1.
- The couplings / gearing used are rigid and low backlash and not flexible rubber type couplings.
- The motor / drive combination is capable of producing sufficient torque to accelerate the load at the required rate.

We can say that typically on a system with a 4096-ppr encoder we can achieve a steady state following error of between +/-10 – +/-50 counts per Metre travelled.

In the example in section 4.2.2 we can calculate 50 counts of the slave axis equates to 0.03mm/Metre, therefore the likely achievable accuracy of the positioning system is worst-case +/-0.03mm/Metre. Other errors from mechanical tolerances will reduce the achievable accuracy of the machine.

If the resolution is increased, such as by fitting SinCos encoders then the accuracy can be improved, however it is not a linear relationship, if we double the encoder resolution then we should not expect half the error.

If the ratio between master and slave is large then slight movements on the master axis cause large changes in required position in the slave so the net effect is a greater following error than if the gear ratio was nearer 1:1.

5.5 Commissioning Sequence

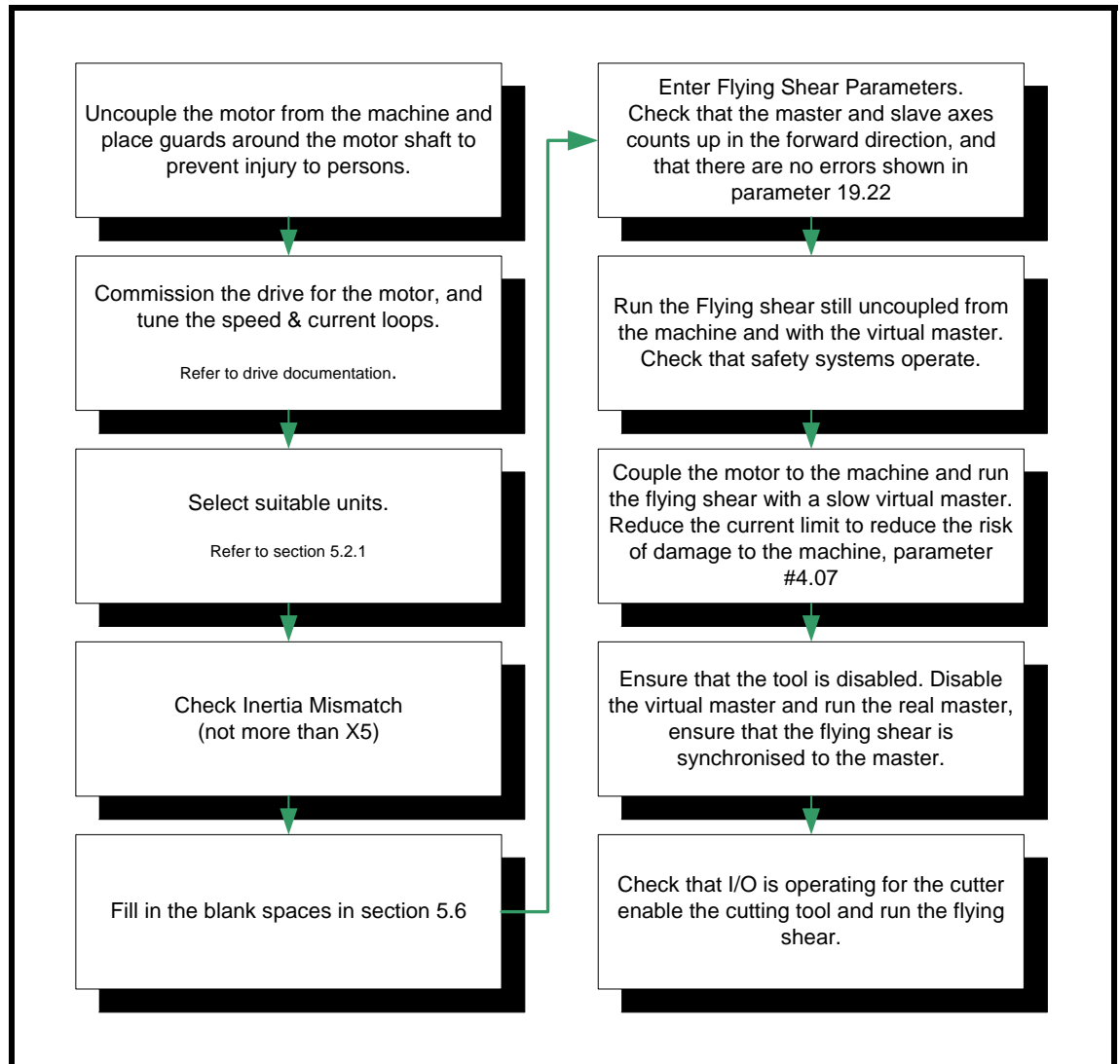

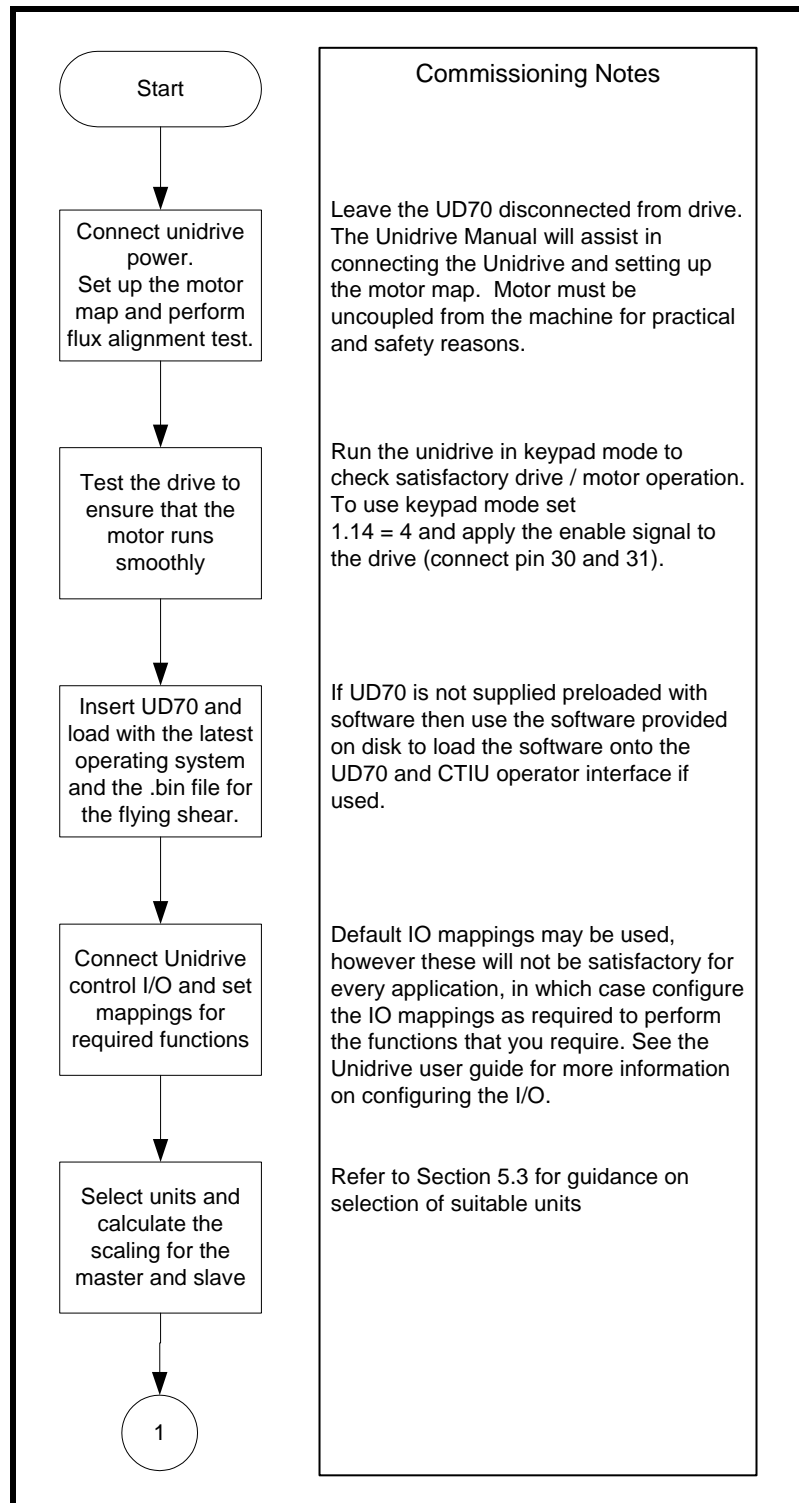

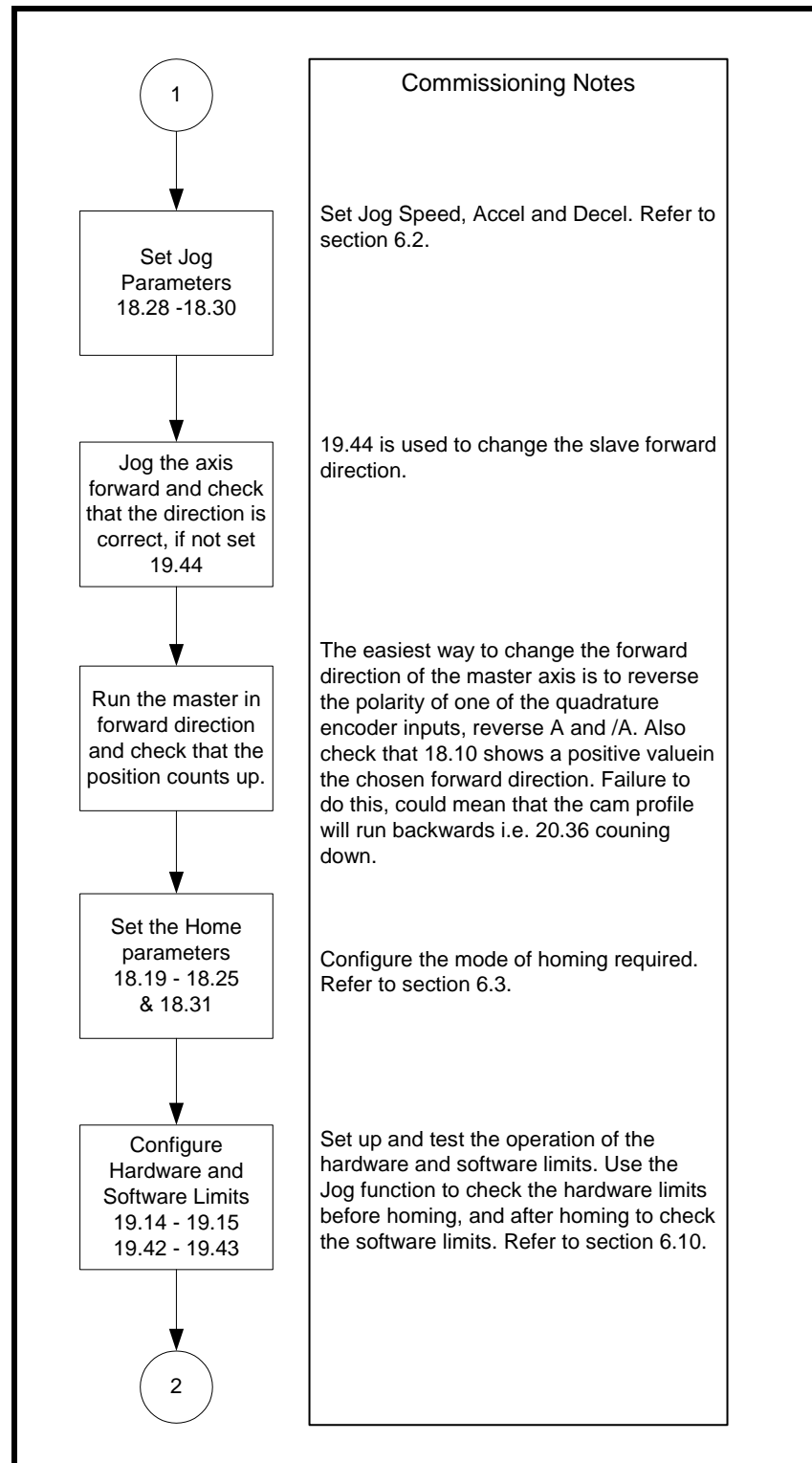

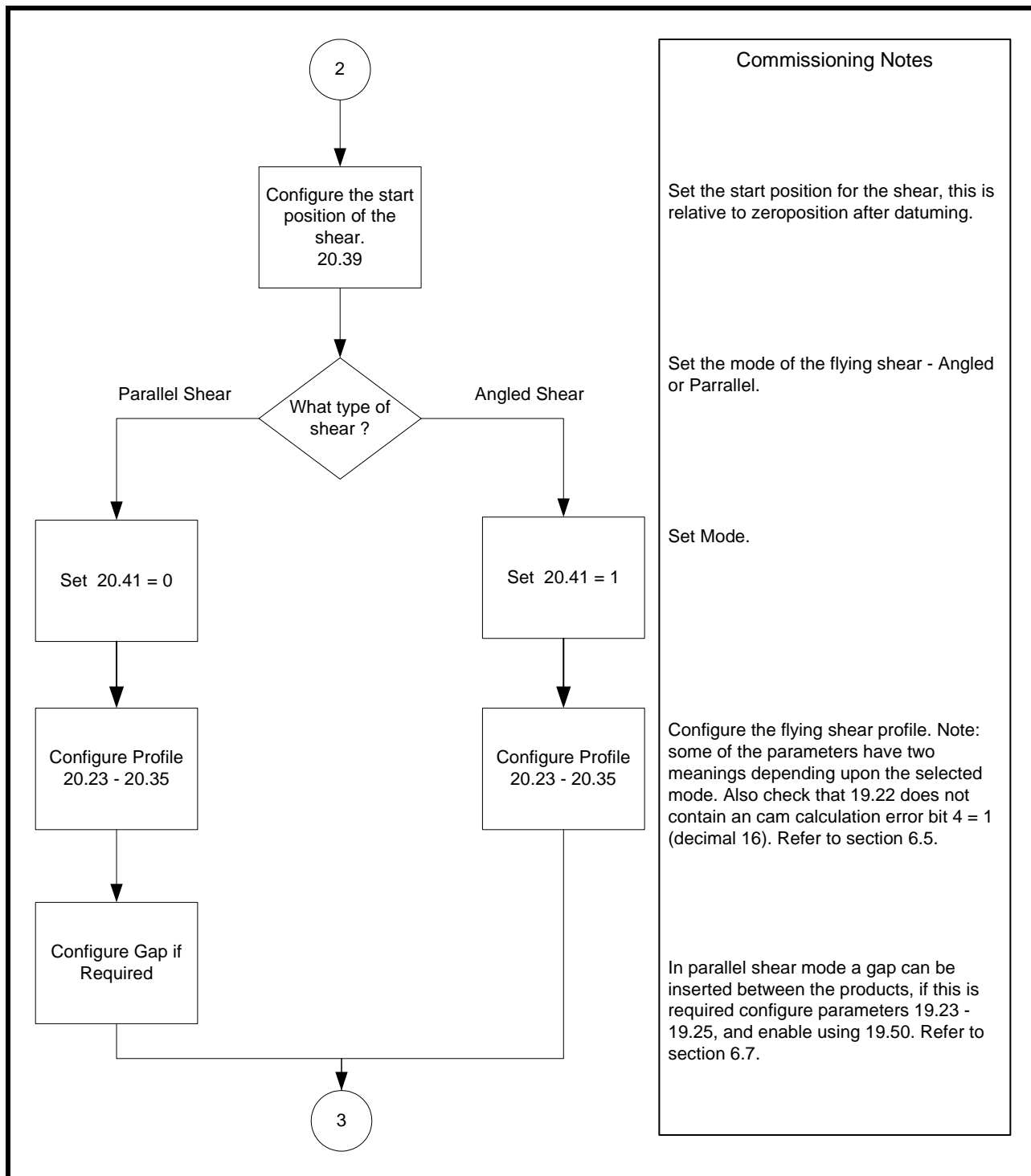

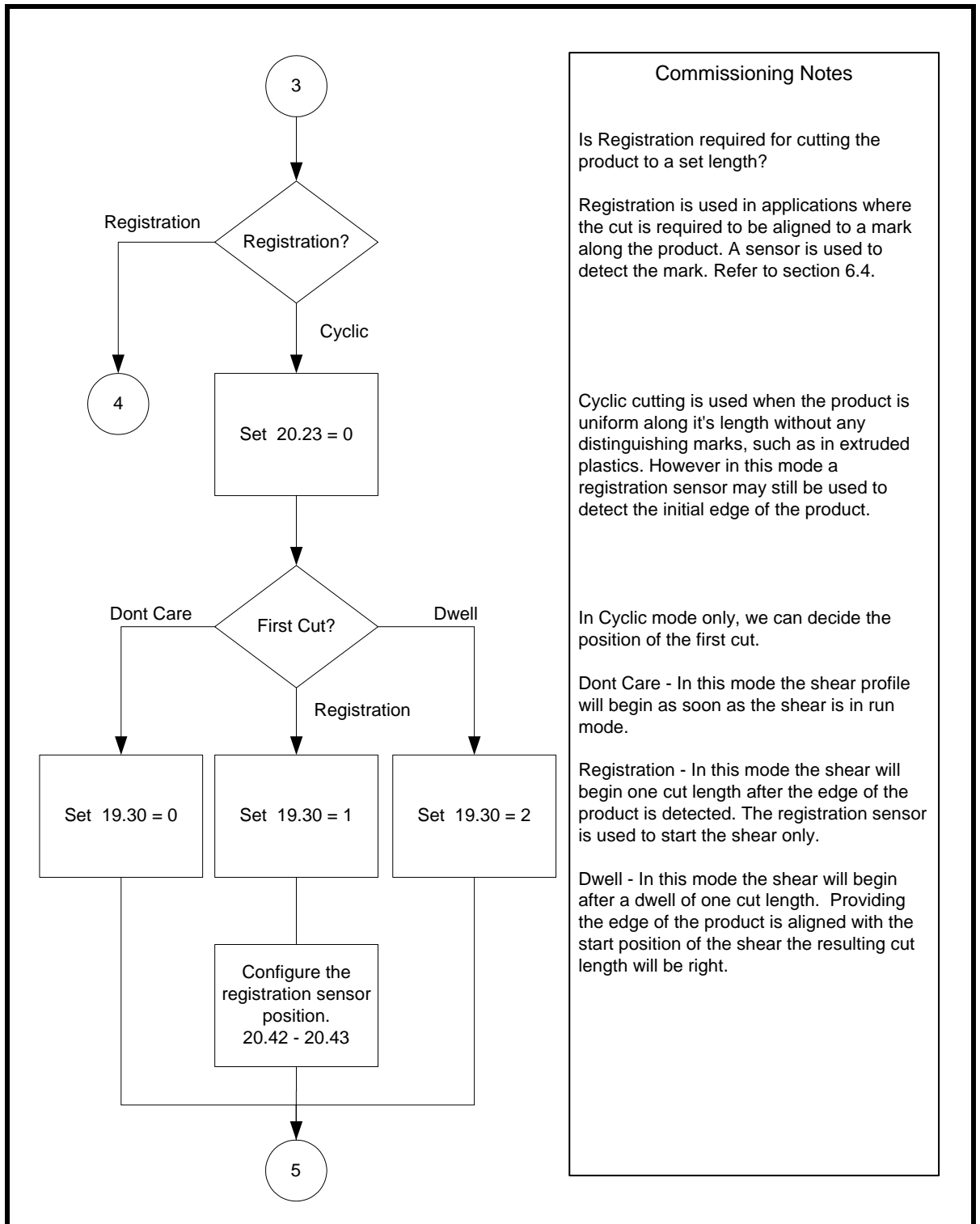

Commissioning Notes

Is Registration required for cutting the product to a set length?

Registration is used in applications where the cut is required to be aligned to a mark along the product. A sensor is used to detect the mark. Refer to section 6.4.

Cyclic cutting is used when the product is uniform along it's length without any distinguishing marks, such as in extruded plastics. However in this mode a registration sensor may still be used to detect the initial edge of the product.

In Cyclic mode only, we can decide the position of the first cut.

Dont Care - In this mode the shear profile will begin as soon as the shear is in run mode.

Registration - In this mode the shear will begin one cut length after the edge of the product is detected. The registration sensor is used to start the shear only.

Dwell - In this mode the shear will begin after a dwell of one cut length. Providing the edge of the product is aligned with the start position of the shear the resulting cut length will be right.

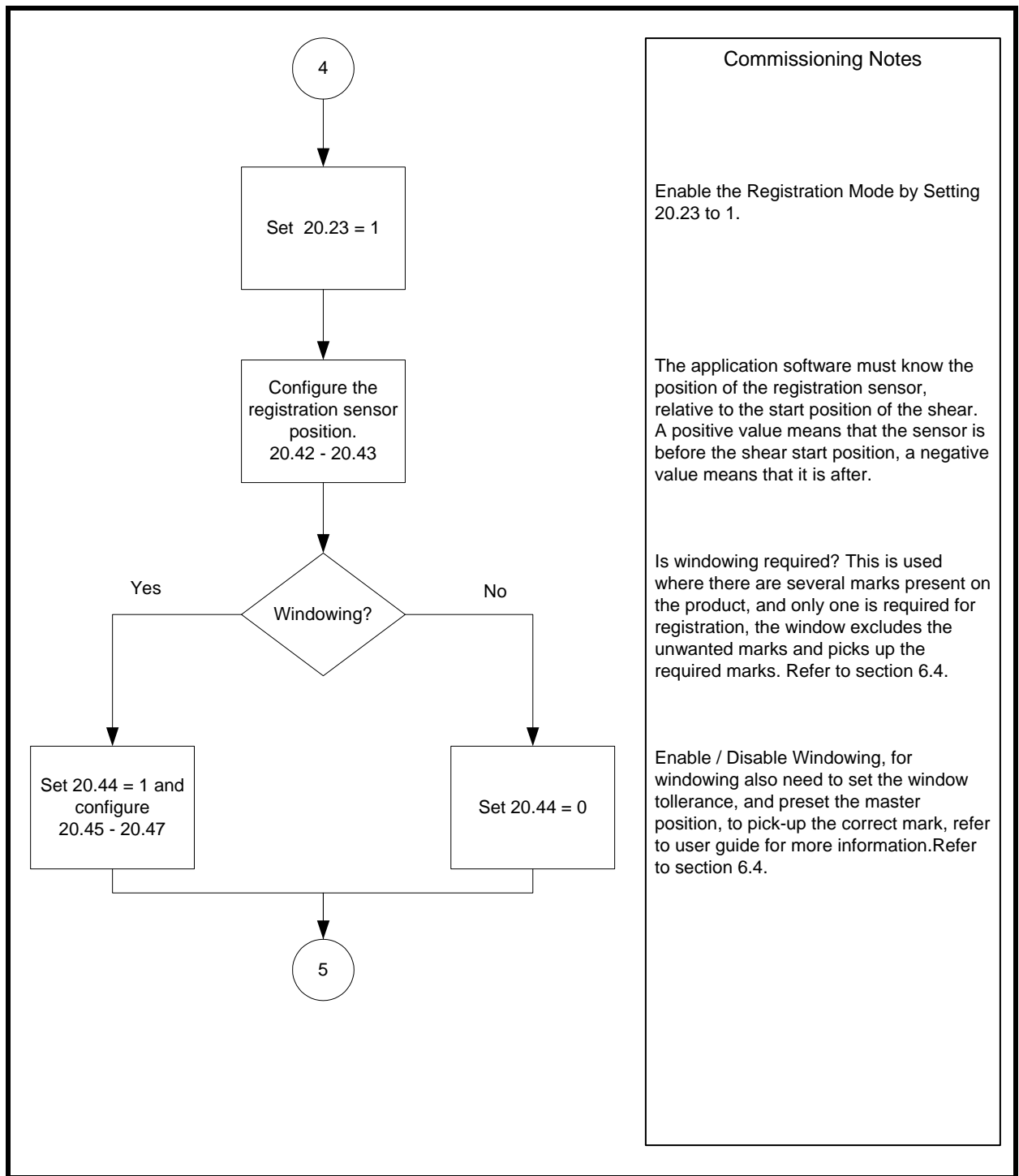

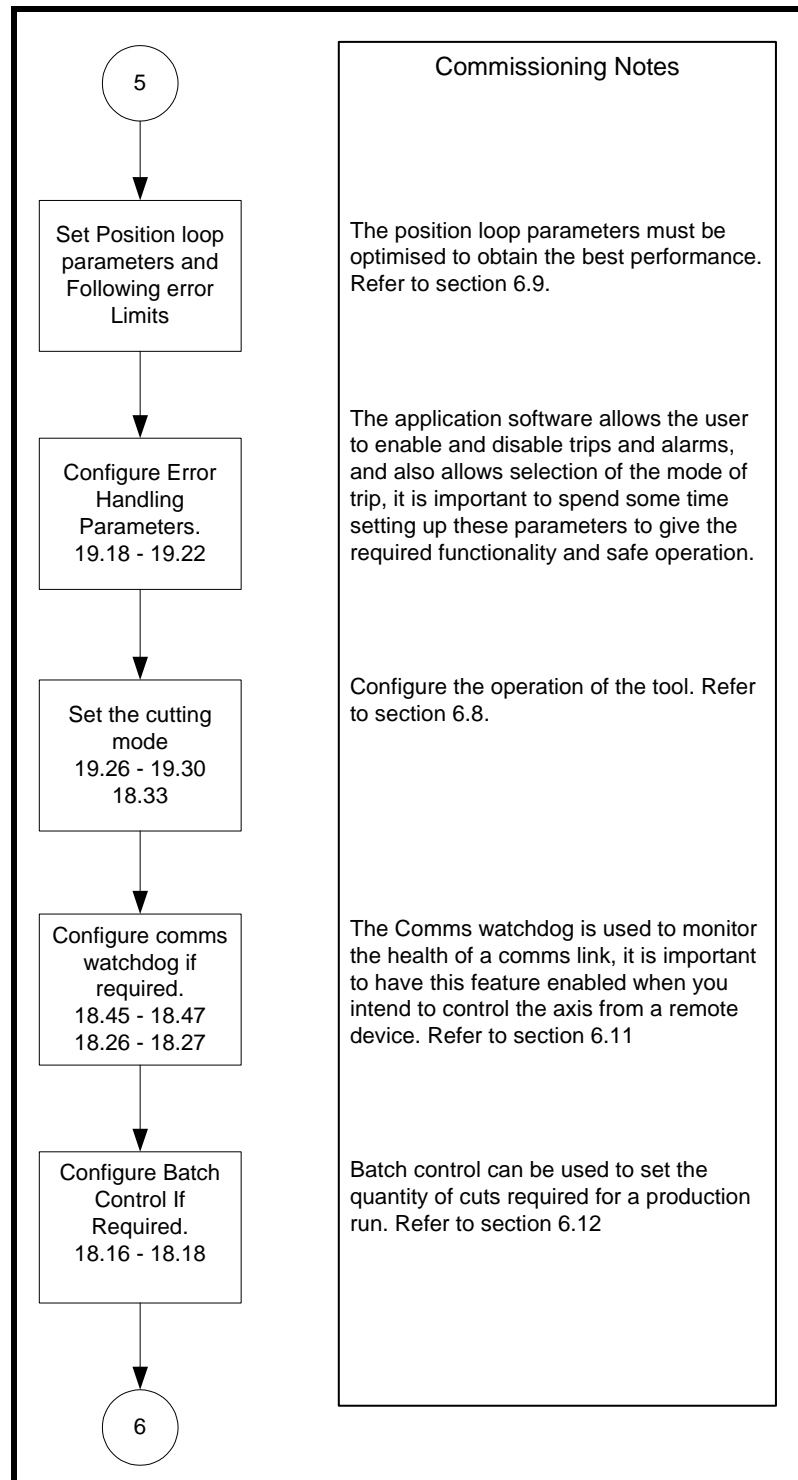

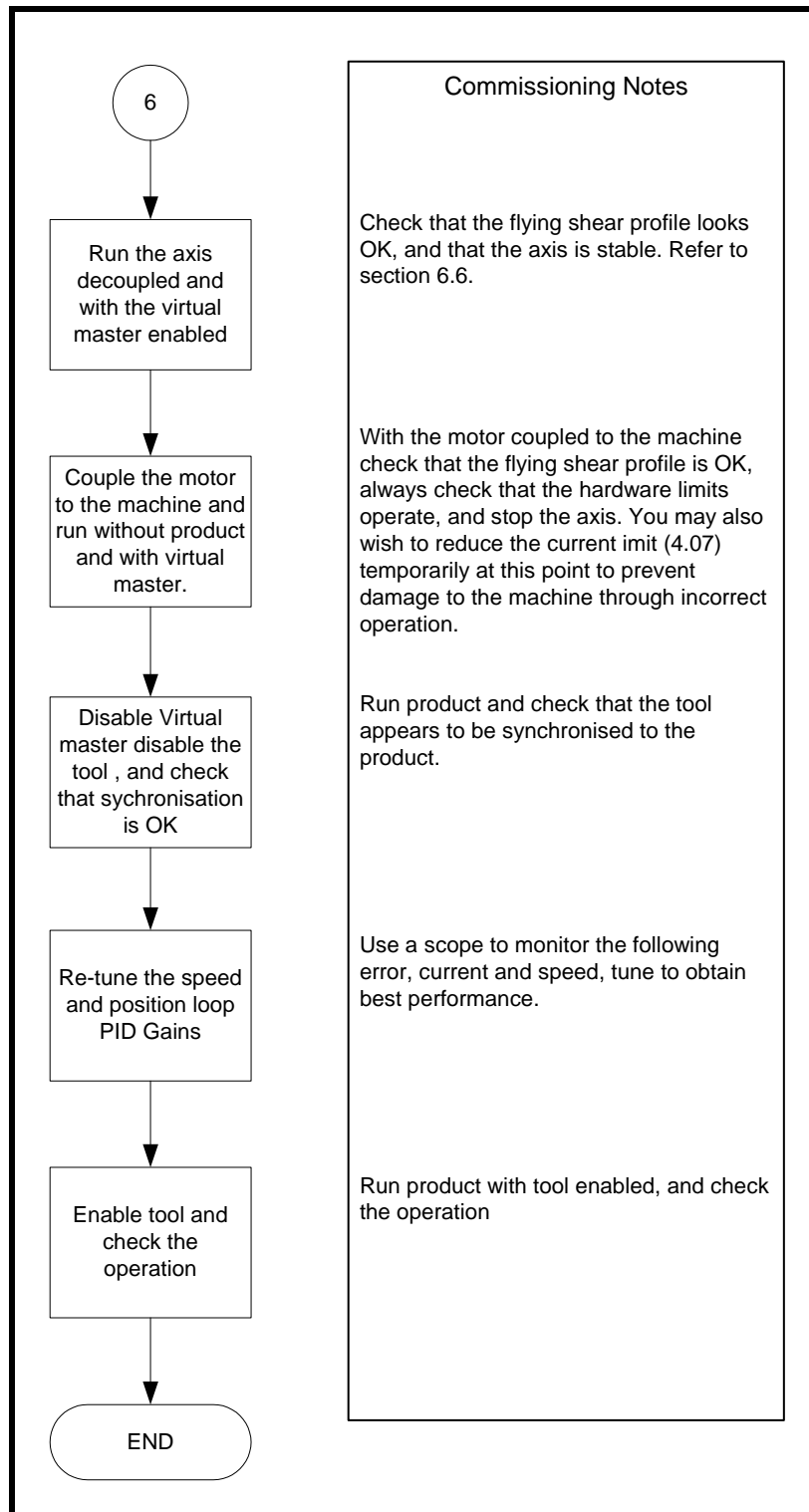

5.6 Application Set-up Parameters

1. Scaling Refer to section 5.3 or 7.2			
NOTE scaling is only updated on power-up, or by setting update scaling (parameter 18.37).	Master Numerator	18.13	
	Master Denominator	18.12	
	Slave Numerator	18.15	
	Slave Denominator	18.14	
2. Jogging Refer to section 6.2 or 7.2			
What speed do you want to Jog	Units / s	18.28	
Set the Jog Acceleration Rate	Units/s/s	18.29	
Set the Jog Deceleration Rate	Units/s/s	18.30	
3. Homing Refer to section 6.3 or 7.2			
Is the home switch in the forward or reverse direction NOTE Forward direction is when the flying shear travels in the same direction as the normal flow of the product.	1 = Forwards 0 = Reverse	18.22	
What Home mode is required	0 = Search for leading edge of home switch. 1 = Search for leading edge of Home switch and then datum on the next motor encoder marker pulse.	18.20	
What speed do you want to search for the home?	Home Search Speed Units/s	18.19	
What speed do you want to back-off the home switch?	Home Back-off Speed Units/s	18.21	
What Acceleration / Deceleration rates do you want to use for homing	Homing Accel / Decel Units/s/s	18.23	
The homing sequence can fail if the time it takes exceeds a preset time. How long do you wish to make the time-out.	Homing Time-out Time is ms	18.24	
The position that you want to pre-set the position loop to at the home position.	Zero Position Units	18.25	
What is the polarity of the home switch	1 = Normally Closed 0 = Normally Open	18.31	

4. Registration Refer to section 6.4 or 7.2			
How far is the registration input located from the flying shear start position?	Registration Sensor Position. Units	20.43	
Do you want to add a fine trim to the registration sensor position?	Registration Sensor Position fine offset. Units/1000	20.42	
Do you want to use windowing so that the registration sensor excludes marks outside the window?	Enable Windowing. 1 = Enable 0 = Disable	20.44	
The position will roll over to zero when the cut length is reached, the window will be open before and after the rollover within a tolerance.	What Tolerance do you want to apply to the window? Units	20.45	
The master position may be preset to the value of parameter 20.47 when a transition from 0 – 1 occurs in parameter 20.46.	Master position preset.	20.47	
5. Flying Shear Profile (Parallel) Refer to section 6.5, 6.10 and 7.2			
Do you want the flying shear to synchronise to a mark on the product, or do you want the flying shear to run cyclically?	1 = Cut on Mark 0 = Run Cyclically	20.23	
If cyclic mode is selected you can select when the first cut is executed.	0 = Cut Immediately 1 = Cut Using the registration sensor. 2 = Cut after one cut length.	19.30	
If cyclic mode is selected you can choose the mode of optimisation for the return section of the profile. If fast is selected then the shear will return at the maximum speed and dwell before the next cycle. If slow is selected the shear will return with enough pace to achieve the next cut without any need to dwell.	0 = Slow 1 = Fast	20.40	
What is the start position for the flying shear?	Units	20.39	
What cut length do you want to achieve?	Enter Cut Length In Units	20.24	
Do you want to add a fine adjustment to the cut length?	Enter a Fine Offset To The Cut Length. Units / 1000	20.32	

What is the travel available for the shear? This is taken as the distance from the start position of the flying shear to the hardware / software forward limits.	Units	20.25	
What is the accel / decel rate for the shear during the fly (forward) part of the profile.	Units/s/s	20.26	
What is the accel / decel rate for the shear during the return (reverse) part of the profile.	Units/s/s	20.27	
What is the Maximum Speed of the master axis during this profile?	Units/s	20.28	
The synchronous part of the flying shear profile, is split into three areas, settling time, the cut time and the tool rise time. If the cut time needs to be in real Time at all speeds, set 18.50 to 1 (Refer to section 6.8.2).	Settling Time Milliseconds	20.29	
	Tool Down/Cut Time Milliseconds	20.30	
	Tool Up Time Milliseconds	20.31	
The flying shear will only attempt to activate the cut output if the following error (FE) is within the FE cut limit.	FE Cut Limit Encoder Counts	20.33	
How do you want the flying shear to accelerate, Linear or S-Ramped? NOTE The S-ramp profile should not be used in conjunction with fieldbus options, as it may cause the drive to spuriously trip.	1 = S-Ramp 0 = Linear	20.35	
At what rate would you like the flying shear to decelerate if a limit switch is hit.	Set Fast Decel Rate Units/s/s	20.34	
5. Flying Shear Profile (Angled) Refer to section 6.5, 6.10 and 7.2			
Enable angled shear	= Parallel 1 = Angled	20.41	
Do you want the flying shear to synchronise to a mark on the product, or do you want the flying shear to run cyclically?	1 = Cut on Mark 0 = Run Cyclically	20.23	
If cyclic mode is selected you can select when the first cut is executed.	0 = Cut Immediately 1 = Cut Using the registration sensor to detect the edge of the material. 2 = Cut after one cut length.	19.30	

You can choose the mode of optimisation for the return section of the profile. If fast is selected then the shear will return at the maximum speed and dwell before the next cycle. If slow is selected the shear will return with enough pace to achieve the next cut without any need to dwell.	0 = Slow 1 = Fast	20.40	
What is the start position for the flying shear?	Units	20.39	
What cut length do you want to achieve?	Enter Cut Length In Units	20.24	
Do you want to add a fine adjustment to the cut length?	Enter a Fine Offset To The Cut Length. Units / 1000	20.32	
What is the angle between the shear and the material conveyor?	0.01 degrees	20.25	
What length is the start distance? (not less than 20.29)	Units	20.26	
What is the accel / decel rate for the shear during the return (reverse) part of the profile.	Units/s/s	20.27	
What is the Maximum Speed of the master axis during this profile?	Units/s	20.28	
What distance is the shear to be accelerated over?	Units	20.29	
What distance do you want the shear to be synchronised for?	Units	20.30	
What distance do you want to decelerate the shear in?	Units	20.31	
The flying shear will only attempt to activate the cut output if the following error (FE) is within the FE cut limit.	FE Cut Limit Encoder Counts	20.33	
How do you want the flying shear to accelerate, Linear or Sinusoidal Ramped? NOTE The S-ramp profile should not be used in conjunction with fieldbus options, as it may cause the drive to spuriously trip.	1 = Sinusoidal Ramp 0 = Linear	20.35	
At what rate would you like the flying shear to decelerate if a limit switch is hit.	Set Fast Decel Rate Units/s/s	20.34	

6. Virtual Master Refer to section 6.6 or 7.2			
Enable Virtual Master.	1 = Enabled 0 = Disabled	20.37	
Virtual Master Speed.	Virtual Master Speed Units/s	20.38	
7. Tool Control Refer to section 6.8 or 7.2			
Enable the tool cut output when synchronised.	1 = Enable 0 = Disabled	19.49	
Tool manual cut.	1 = Cut 0 = No Cut	19.31	
After the tool has synchronised then the tool up input (parameter 19.46) is checked to ensure that the flying shear is able to decelerate, if the tool is not raised then we can handle the fault in one of two ways:	1 = extend the synchronisation to the master, and stop the master. 0 = Decelerate as normal.	18.33	
Cutter Mode. Only modes 0 and 1 are available in angled shear mode.	0 = Set output during the cut part of the cycle, ignore tool up/down signals 1 = Use tool up signal 2 = Use tool down signal 3 = use tool up and down signals	19.26	
Cut at start	0 = don't cut on start 1 = cut on start	19.27	
8. Position Loop Refer to section 6.9 or 7.2			
Position Loop Velocity Feed Forward Gain	Set to 1000	19.12	1000
Position Loop Proportional Gain	Proportional Gain Val / 1000	19.13	
Position Loop Proportional Term Limit	Set as a percentage of the drive maximum speed.	19.16	
FE Limit, Following Error Maximum Value Before An Error Condition will Occur	FE Limit Encoder Counts	19.11	
At Position Tolerance, this is the tolerance for the at position flag.	Units/1000	19.17	
Change forward direction of the axis	0 = Normal 1 = Reverse	19.44	

9. Hardware and Software Limits Refer to section 6.10 or 7.2			
At what positions do you want to put the software limits?	Forward Limit Units	19.14	
	Reverse Limit Units	19.15	
What is the polarity of the Hardware Limits	1 = Normally Closed 0 = Normally Open	19.42	
Do you want to disable the limit switches during homing; this will be needed if you use the limit switch as a homing switch, or if the homing switch is outside the limit switch.	Enable Limits during homing. 1 = Disable Limits 0 = Enable Limits	19.43	
10. Watchdog Refer to section 6.11 or 7.2			
Watchdog Enable	1 = Enable 0 = Disable	18.45	
Watchdog In Error Delay, if the watchdog clock from the remote device does not change state within the time allowed then an error state would result.	Watchdog Error Delay. Milliseconds	18.26	
Watchdog Out Time Period, This sets frequency that the clock will change state.	Watchdog time period. Milliseconds	18.27	
11. Batch Control Refer to section 6.15 or 7.2			
Enable Batch Control	1 = Enable 0 = Disable	18.16	
Batch Quantity		18.17	
Batch Reset	1 = Reset	18.38	

Command Parameters

Update Scaling & Direction	0 – 1 Transition = Update	18.37	Not Mapped
Manual Tool Cut Command	0 – 1 Transition = Cut	19.26	Not Mapped
Drive / Software Reset	1 = Reset	19.32	Not Mapped
Shear Run Command	1 = Run 0 = Stop	19.33	Mapped to F3
Go to Start Position	1 = Go to Start	19.34	Not Mapped
Local / Remote Control	1 = Remote	19.35	Controlled by fieldbus control word
Jog Forward	1 = Jog	19.36	Not Mapped
Jog Reverse	1 = Jog	19.37	Not Mapped
Home / Datum Command	0 - 1 Transition = Home	19.38	Mapped to Ain 2 through thresholds
Abort Motion	1 = Abort	19.39	Not Mapped
Enable Tool	1 = Enabled	19.49	Not Mapped
Preset Master Position	1 = Preset	20.46	Not Mapped

6 Functional Description

6.1 Overview

The diagram below illustrates the software architecture.

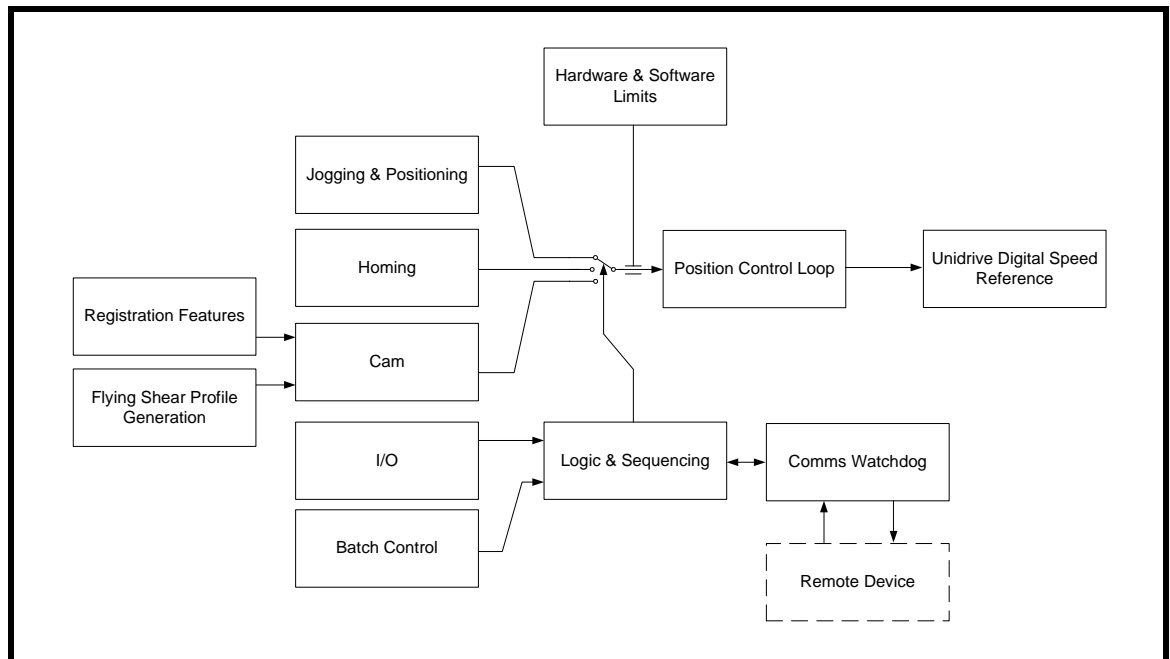

6.2 Jogging & Positioning

Jogging can be done at any time provided the flying shear axis is idle and the tool is in the up position. After Jogging, the axis can be sent back to the start position ready for a flying shear profile. Hardware limits are always active when jogging; the software limits are also active providing the system has been homed.

NOTE The Jog command is a rising edge triggered. If Jog forward and Jog reverse are selected at the same time, the first one detected takes priority.

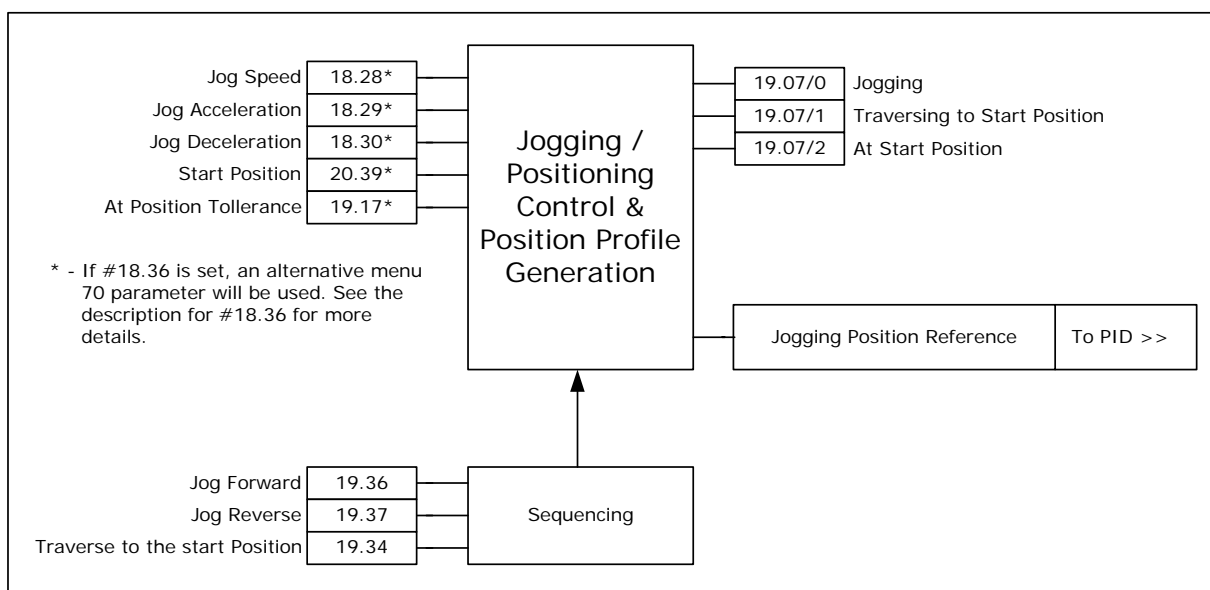

6.3 Homing / Datuming

To perform a home the shear

- Must not be in another mode e.g. Jogging, cutting.
- The drive must be healthy and enabled
- The Tool must be in the up position
- Sequence Abort (19.39) must not be active

During Homing:

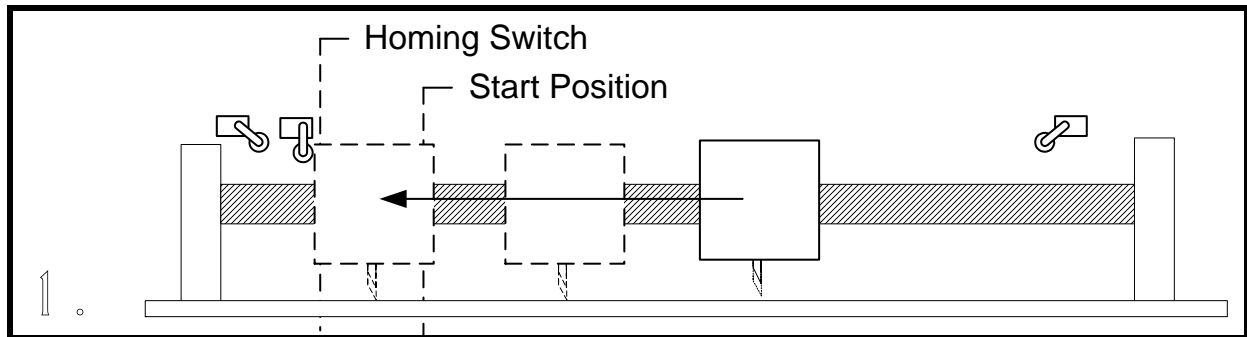

The flying shear carriage travels at home speed to find the home switch.

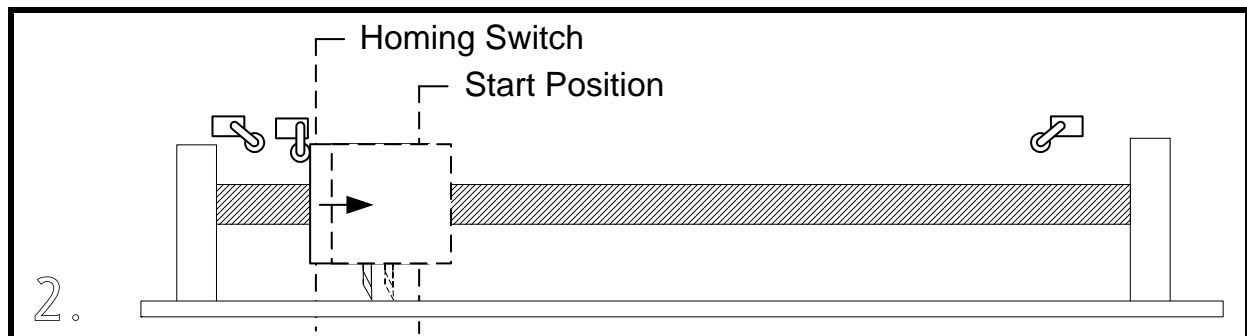

The flying shear reverses at back-off speed, a percentage of the home speed (18.19), until the home switch is reset, or finds the next marker pulse; the position is then pre-set to the zero position preset (18.25).

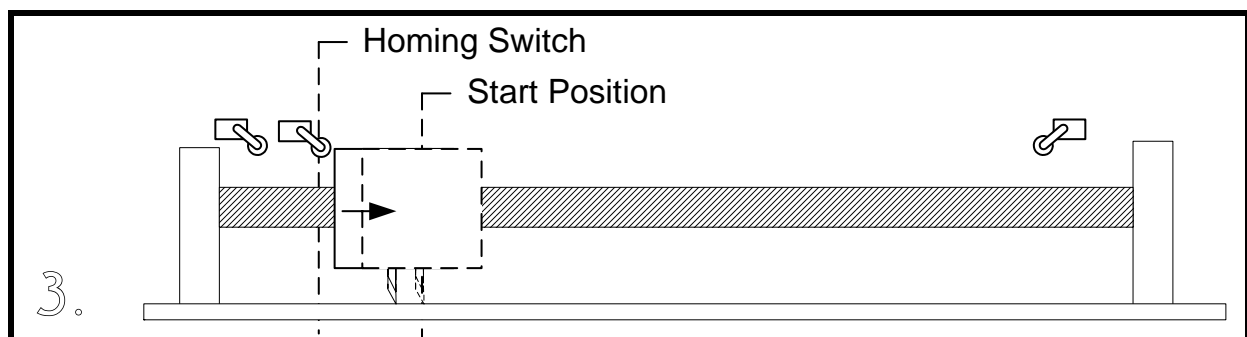

The carriage travels to the start position, ready to run.

NOTE If you select a low home acceleration / deceleration rate (18.23), with a high home speed (18.19), during homing the shear may overshoot the home switch and crash the carriage. This is most likely to cause damage if 19.43 is set disabling the limit switches whilst a home sequence is completed. The lower the home back-off speed, the more accurate the homing routine will be.

Homing Timing Diagram

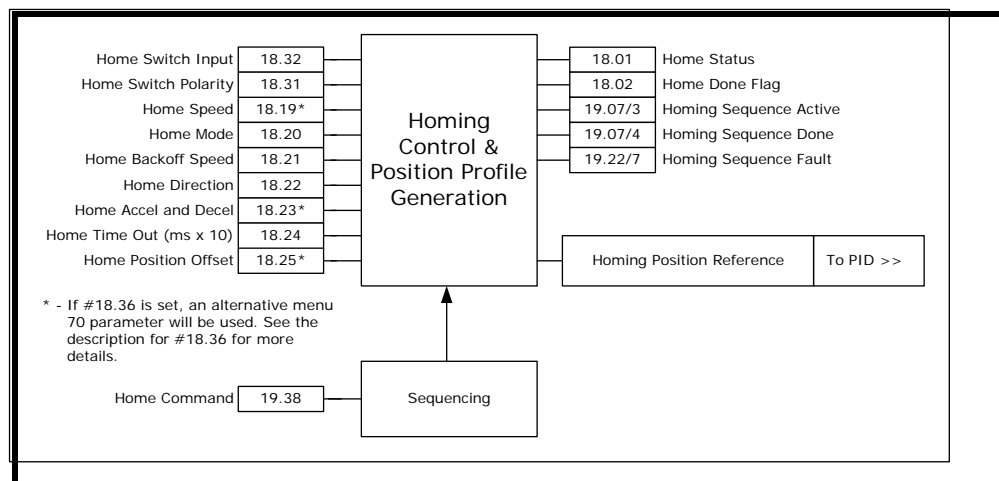
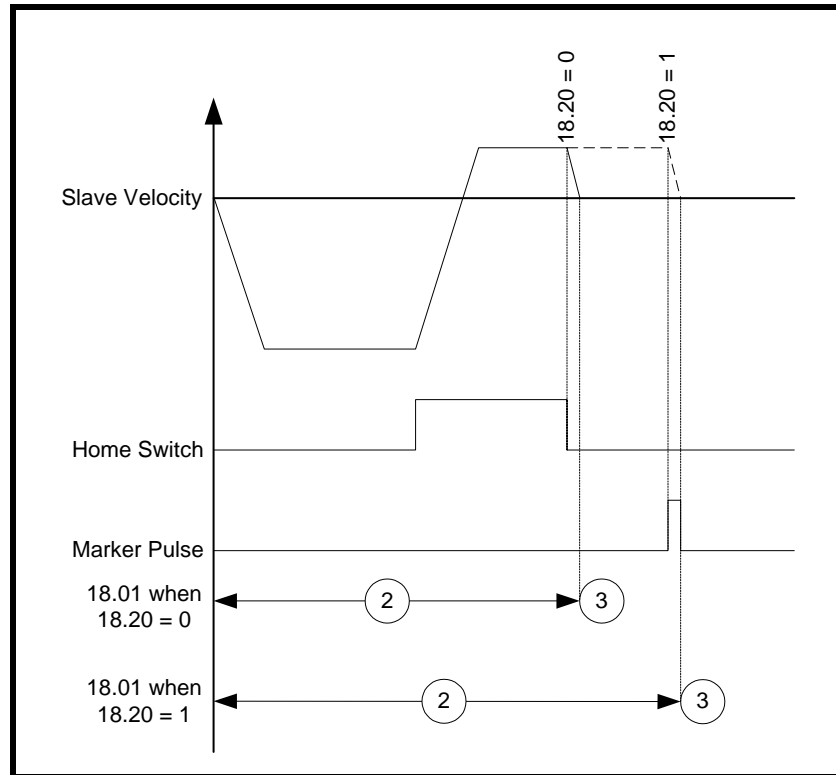

6.4 Registration

The registration sensor can have different functions depending upon the mode of the flying shear, cyclic or Registration.

In cyclic mode the flying shear can be used to detect the initial product edge and allow the first cut to be as accurate as the following cuts, setting the first cut mode to 1 (19.30) enables this function.

In Registration mode the registration sensor is used to set the position where the flying shear will synchronise with the master. The sensor could be used to detect the position of a mark on a printed product, or alternatively to detect individual products that are randomly spaced out.

The position of the registration sensor is important. Once a registration event has occurred there must be enough space for the shear to accelerate, and synchronise, but if the sensor is located some distance from the shear some loss of accuracy may result.

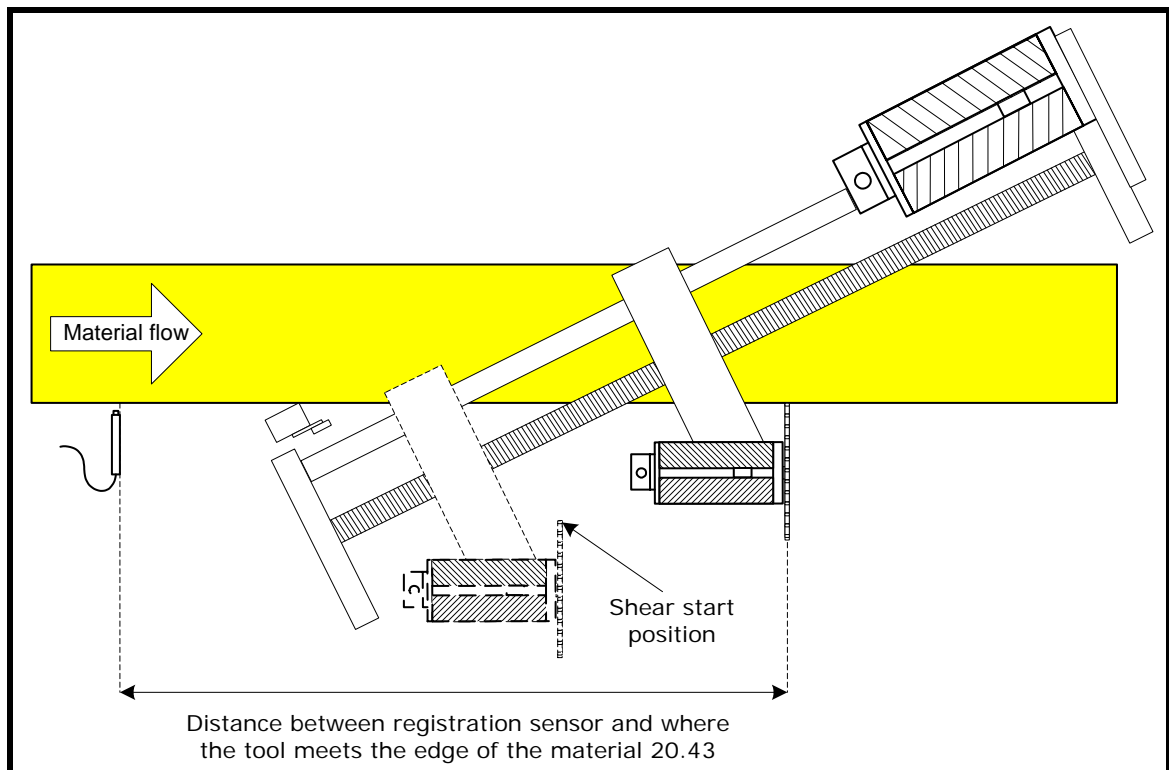
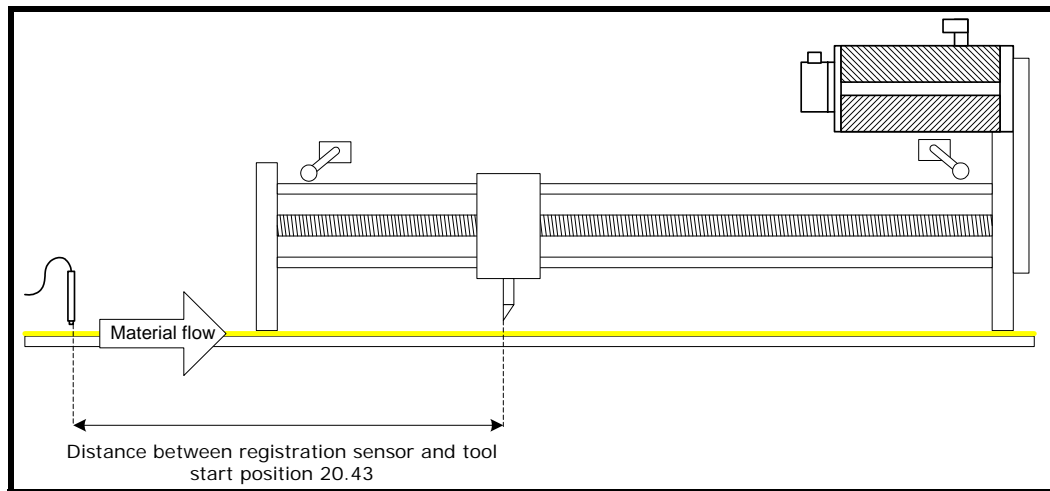

The registration offset between the registration sensor, and the knife start position are entered into the registration offset (20.43) and fine offset (20.42), and allow a resolution of up to 0.001 units. If this is entered accurately then the flying shear will synchronise with the position where the registration sensor detected the registration event. However, this is not always desirable, it may that you wish to detect a mark, but synchronise a fixed distance from that position, this can be achieved simply by adding or subtracting from the distance between the sensor and the knife start position, though, there must still be enough distance for the flying shear to accelerate and synchronise with the new position.

Windowing

The registration sensor may detect several marks during each cycle, however, it is common that only one of the marks is relevant for registration purposes, in this case we can enable windowing, which will reject marks that are detected outside a small position window. The cut length (20.24) is used to set the rollover distance relative to the master position count. The window tolerance (20.45) is then used to set how wide the band is where the master will accept a registration mark. As shown in the diagram below, the window is always located about the rollover position. When a valid registration mark is detected, the position of the master is then automatically reset to zero, so that any drift in position will be compensated.

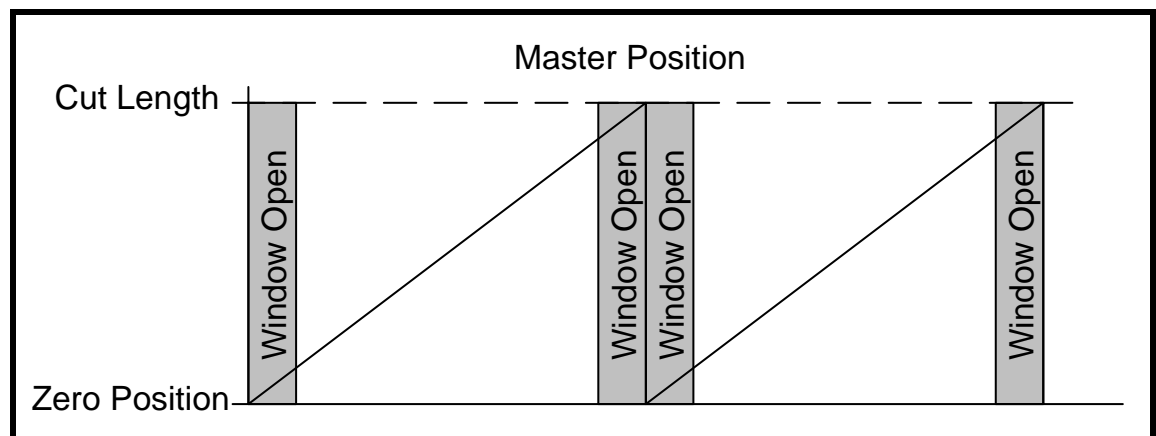

To start the flying shear using the correct mark, the master should be jogged so that the mark is aligned with the registration sensor (it can be just before or on the registration mark), and the master position is then reset to zero by toggling 20.46. When the flying shear is then started, it will cut in the correct position. If it is necessary to configure the window whilst running, 20.46 should be toggled before the required mark and not on it, as you may create a scrap cut.

If the sensor is located further from the start position than one cut length, then there will be several registration positions that need to be recorded. Up to 25 registration events can be buffered at any time.

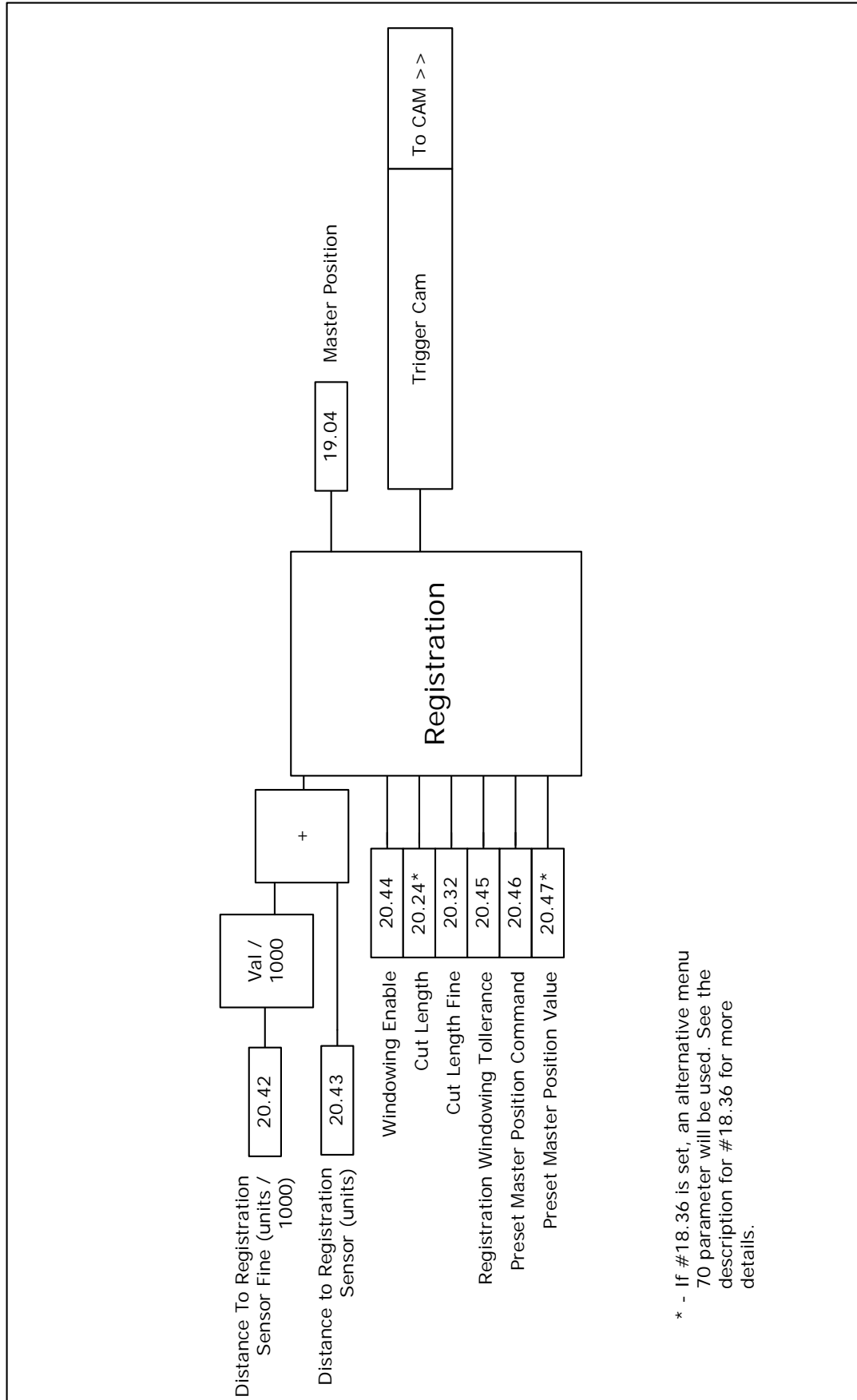

6.5 Flying Shear Profile Calculation

The profile is calculated automatically from parameter data that is entered in real engineering units. The profile is checked to ensure that it can be achieved without exceeding any of the entered parameters, such as shear length. If there is a problem with the entered profile, a cam calculation error will be flagged in the raw alarm word (19.22) bit 4, and the cam status word (20.22) will show the type of error.

From the data a CAM profile is generated with 10 points, as shown below. Not all of the points are always used, such as, we are able to use either a triangular or trapezoidal return profile, whichever is the most efficient, and so while the standard profile has a segment 8, this may or may not be required.

The cam can be recalculated while the flying shear is running. The new cam will be calculated, and will take effect on the following flying shear cycle, providing the cut-length &/or profile information is loaded before point 9 of the current profile. . The current cam / profile point, is displayed by the cam pointer (20.36).

If the new calculated cam has an error, then the cam will not be accepted, and will generate a fault in the fault word (19.22). This can be used to generate an alarm or a trip as required.

The maximum speed for the return profile is determined by parameter 1.06 x 0.99.

Normally there is no need adjust any of the profile parameters whilst the shear is running, however if parameters are changed incrementally via the Unidrive SP keypad whilst the shear is running, it will take 2 profile cycles before the new values are accepted.

Forexample, If the current cut length is 1500mm and you decrement the value in steps of 100 to a new cut length of 1000mm using the keypad, the next cut length will be 1400mm as the cam recalculation instantly grabs the first value it sees, after which it will use 1000mm.

If comms are used to change a profile parameter (e.g. CTIU) whilst the shear is running, the current profile run will be completed, after which the new measurement will be used. N.B. for this to be true the new value has to be entered before the cam pointer, 20.36, reaches 9.

NOTE The first time the flying shear is run, if there is a cam calculation error, You will not be able to start the shear. Check if 19.22 and 19.18 bit 4 is 1 if it is, modify the profile parameters to rectify the fault, and reset the shear (Toggle 19.32).

NOTE If a small cut length can not be achieved because the required cut length (20.24) is smaller than the minimum cut length (20.21), try making the maximum master velocity (20.28) as close as possible to the actual master velocity. If this does not reduce (20.21) sufficiently; for a parallel shear, increase the fly acceleration / deceleration rate (20.26), and for both parallel and angled, increase the return acceleration / deceleration rate (20.27). The acceleration and deceleration rates should only be increased within the limits of the machine, drive and motor.

In the majority Flying Shear applications the profile information like the max speed, acceleration rates and cut times, have been fixed for the worst case line speed. Therefore the cut length could be changed on the fly with no issues, provided the new cut length is changed before CAM point 9 to act on the next cut. This is OK, in cases where the user wishes to cut lengths equal or greater to the minimum cut length that can be achieved for the give profile data, however in some cases the customer wishes to cut shorter lengths, which means that the line speed would have to be reduced to achieve the new length. If the user is in control of the line speed, then the line speed can be clamped from a simple calculation based on the following equation: -

$$\text{Line Speed} = (\text{Max Line Speed} * \text{Required Cut Length} / \text{Min Cut Length at Max Line speed})$$

This equation would be limited to the maximum line speed incase the required cut length is greater than the minimim cut length at maximum speed.

When changing profile data on the fly, it is important to make sure the correct sequence of events is used when changing the cut length, the max profile speed and the actual line speed. As detailed earlier if the minimum cut length was determined by the best case profile for acceleration, motor max speed and tool time at the maximum line speed, then the line speed can be reduced proportionally with cut lengths less the Minimum Cut length in a second SM-Applications module as follows:-

$$\text{Line Speed or Cut Profile Speed} = \text{MIN}((\text{Max Line Speed} * (\text{New Cut Length} / \text{Min Cut Length at Max Line speed})), \text{Max Line Speed})$$

When changing profile data on the fly, these three cases may be considered: -

1. Longer cut length, above minimum cut length at maximum line speed.

This is the simplest case; all that is required is that the new length has to be entered before CAM point 9 on the last cut of the current batch. It will run at the same line speed, and a new dwell distance will be calculated.

2. Shorter cut length, below minimum cut length at maximum line speed.

The following sequence is required: -

- a. Reduce the actual line speed to the required set point for the reduced cut length. If possible set the deceleration for the line so it can reach 0 with in one cut cycle of the shear at maximum line speed using the following formula:

$$(\text{Min cut} - \text{Acceleration Distance} - \text{Settling Distance})$$

e.g. If the Min cut was 3m, Acceleration and Settling Distance 0.5m, and the max line speed was 45m/min, then the deceleration time should be set to less than $(2.5 * 60 / 45) = 3.3\text{sec}$. The lower the decel time is set then better, but care must be taken that it does not cause any slippage or mechanical issues on the line.

- b. Once at the new line speed, set the maximum profile speed with the current cut length, before CAM point 9. This will ensure that the next new cut, (which can be a lot less than the current cut length), can be achieved, successfully.
- c. Set the new cut length before CAM point 9.

To successfully achieve this sequence it may take 3 CAM cycles or 3 cut lengths depending on the deceleration time of the line. Of course point a. has taken the worst case deceleration time, but in reality it will be a lot less as the line will not be ramped to zero. So from this it may take 2 cycles to complete. Therefore on the current cut batch, this sequence will have to take effect 2-3 cuts before the last current cut batch is complete. If the batch on contains 1 cut length then the above will not work, so it is advisable to look ahead, and run the next cut at a lower speed.

3. Longer cut length above current cut length.

The following sequence is required: -

- a. On the last cut of the current profile change Max profile speed and cut length together before CAM point 9.
- b. On acknowledgement the new CAM has been calculated increase the line speed to the new cut length speed.

In the majority of applications with batch control, sequence 2 is most commonly used for stacking/handling purposes. Longest cut lengths on the bottom and the shortest on the top.

To ensure the profile data is acquired at the same time before the next cut, a profile parameter acquire bit has been implemented, Pr18.40. =< V01.03.06 software looked at change of a parameter only, which means that it could not be guaranteed that if two or more profile parameters were changed that they would be both acquired for the next cut. The Acquire bit can be used directly using parameters or using the serial comms control word.

Parallel Shear Profile

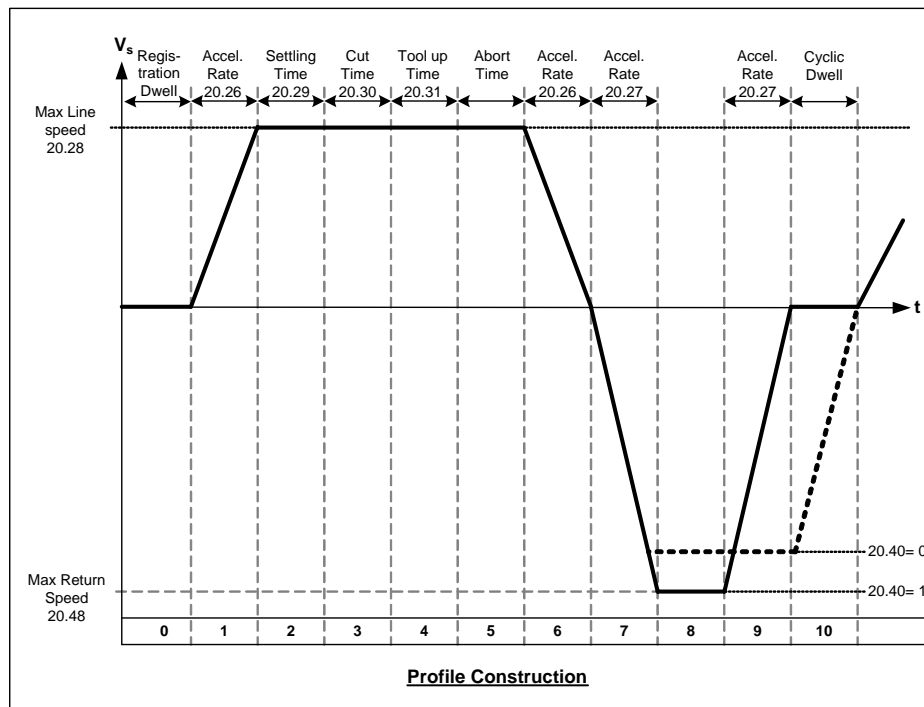

Angled Shear Profile

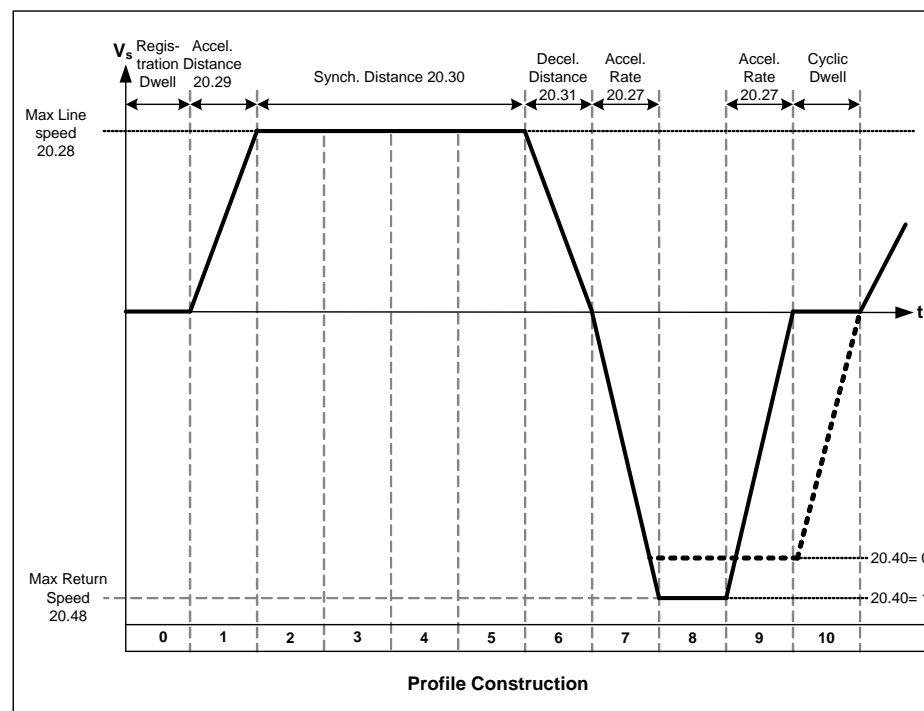

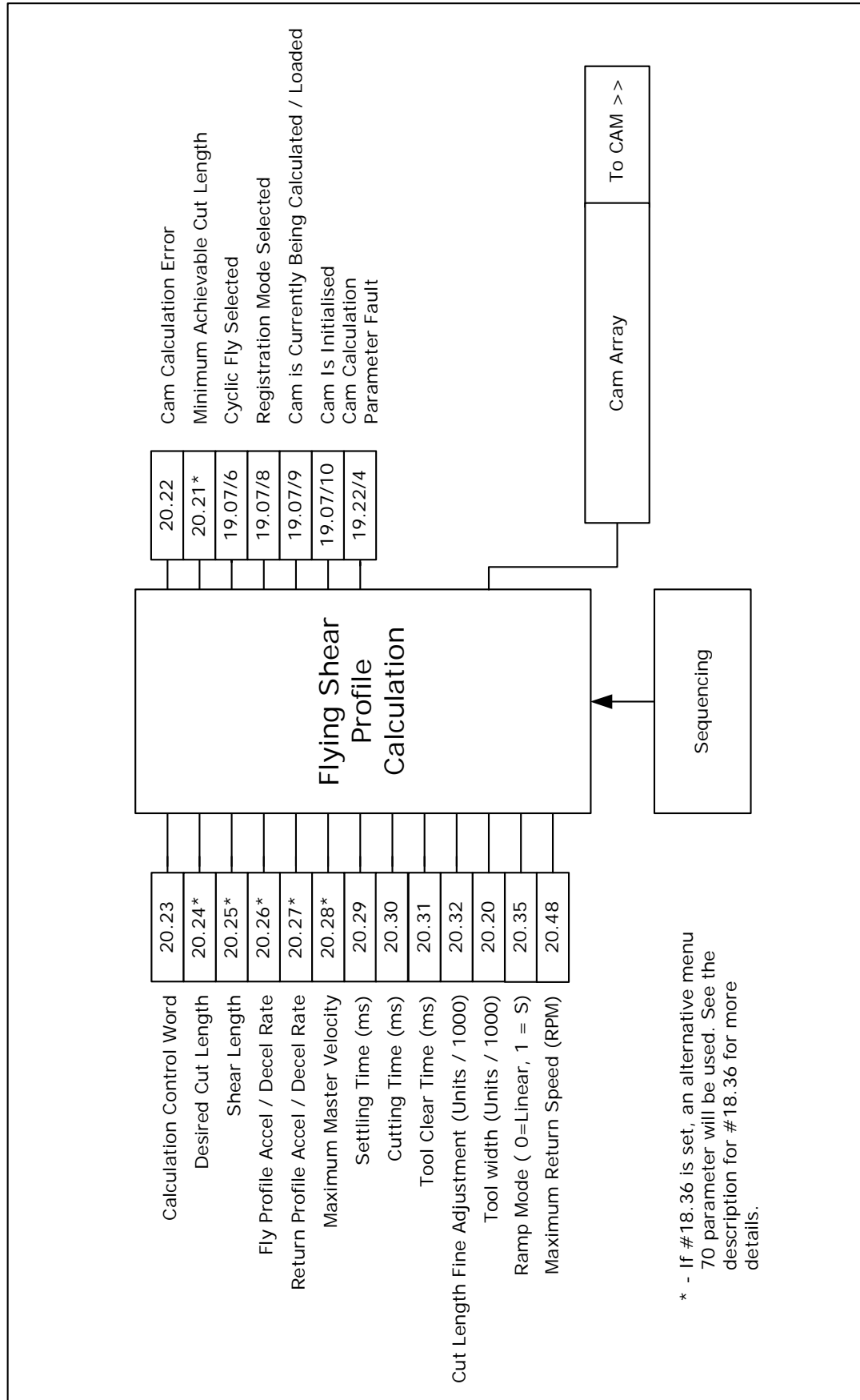

6.6 Cam Control And Virtual Master Control

The Cam accepts inputs from the registration block and the profile calculator, and executes the cam with reference to the master position.

For commissioning purposes a virtual master may be used to check the system without the need to waste product, the virtual master does not have a ramp, and so the speed should not be changed by large increments while the profile is in operation.

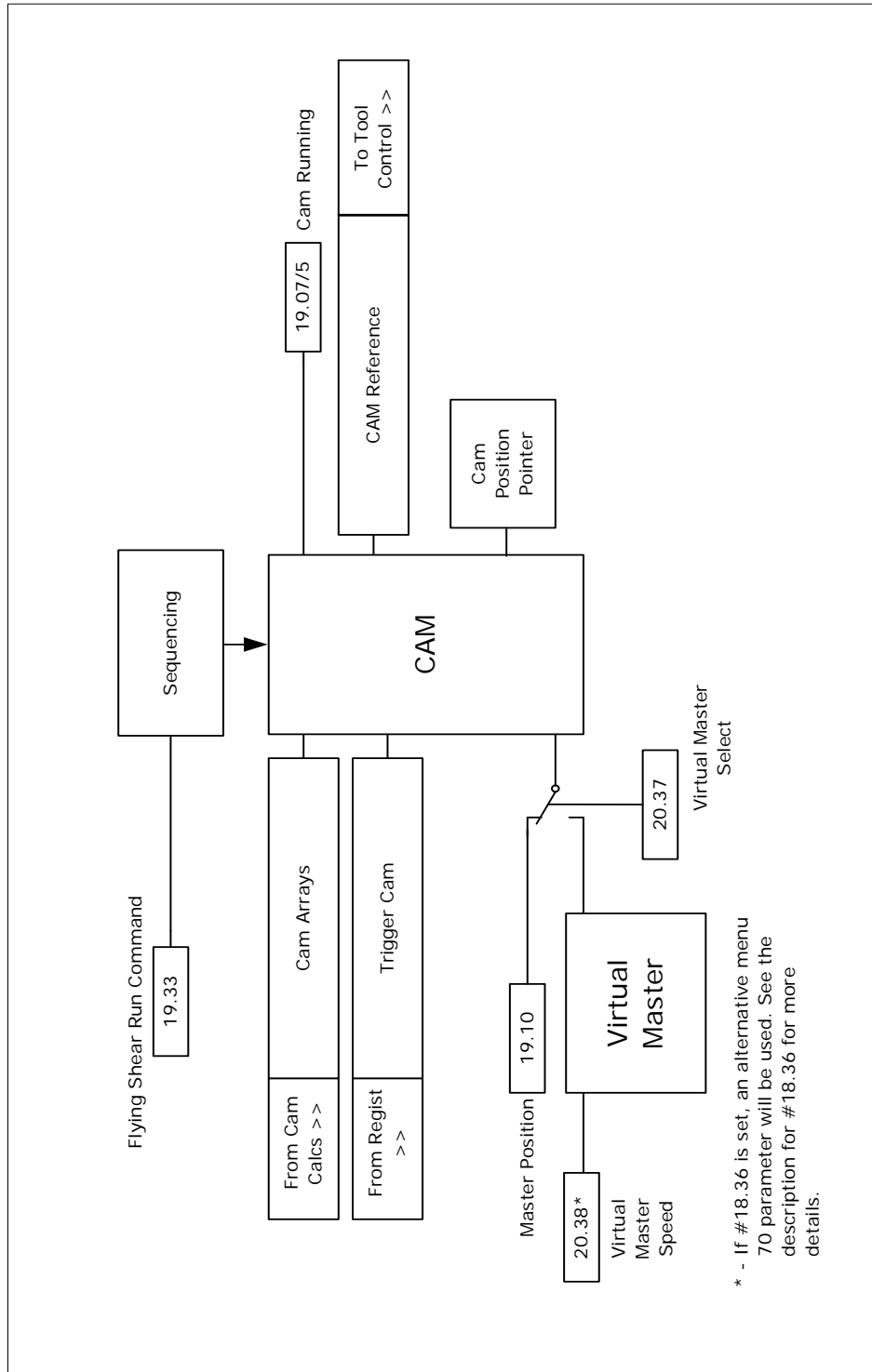

6.7 Gap Profile Generator

Some applications require a gap to be inserted between products by accelerating above synchronisation speed once the cut has been done, using the tool to push the cut material forward (Parallel shear only). This is also useful where the product is viscous, and so requires the product to be completely severed during the cut.

The gap is achieved using a trapezoidal profile generator which is added on to the main position reference to produce the gap, it is important to note that the gap profile is triggered by the tool down signal, or in applications where tool down is not used then it is triggered when the Cam is in tool-up part of the cycle (Cam point 4). The Gap profile is not synchronised to the master like a Cam and so once triggered will continue even if the master is stationary.

NOTE If the shear is in Tool Cut mode 1 (19.26 =1), and Tool Up Time (20.31) is set to low, the gap profile may not have enough time to execute, so the Tool Up time must be increased.

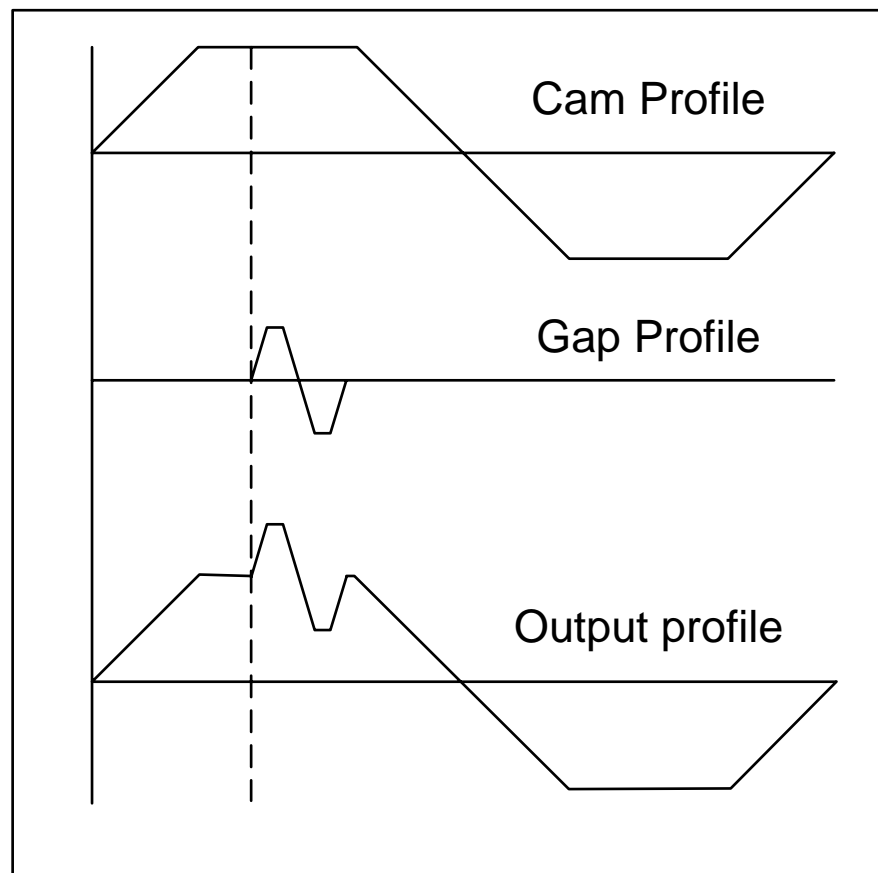

NOTE The overall speed of the Profile and Gap must not exceed the slave motor linear speed detailed below:

$$\text{Max Slave Linear Speed} = \frac{\text{Pr1.06} \times 0.99 \times \text{Pr3.21} \times 4 \times \text{Pr8.14}}{\text{Pr8.15} \times 60} \text{Units/s}$$

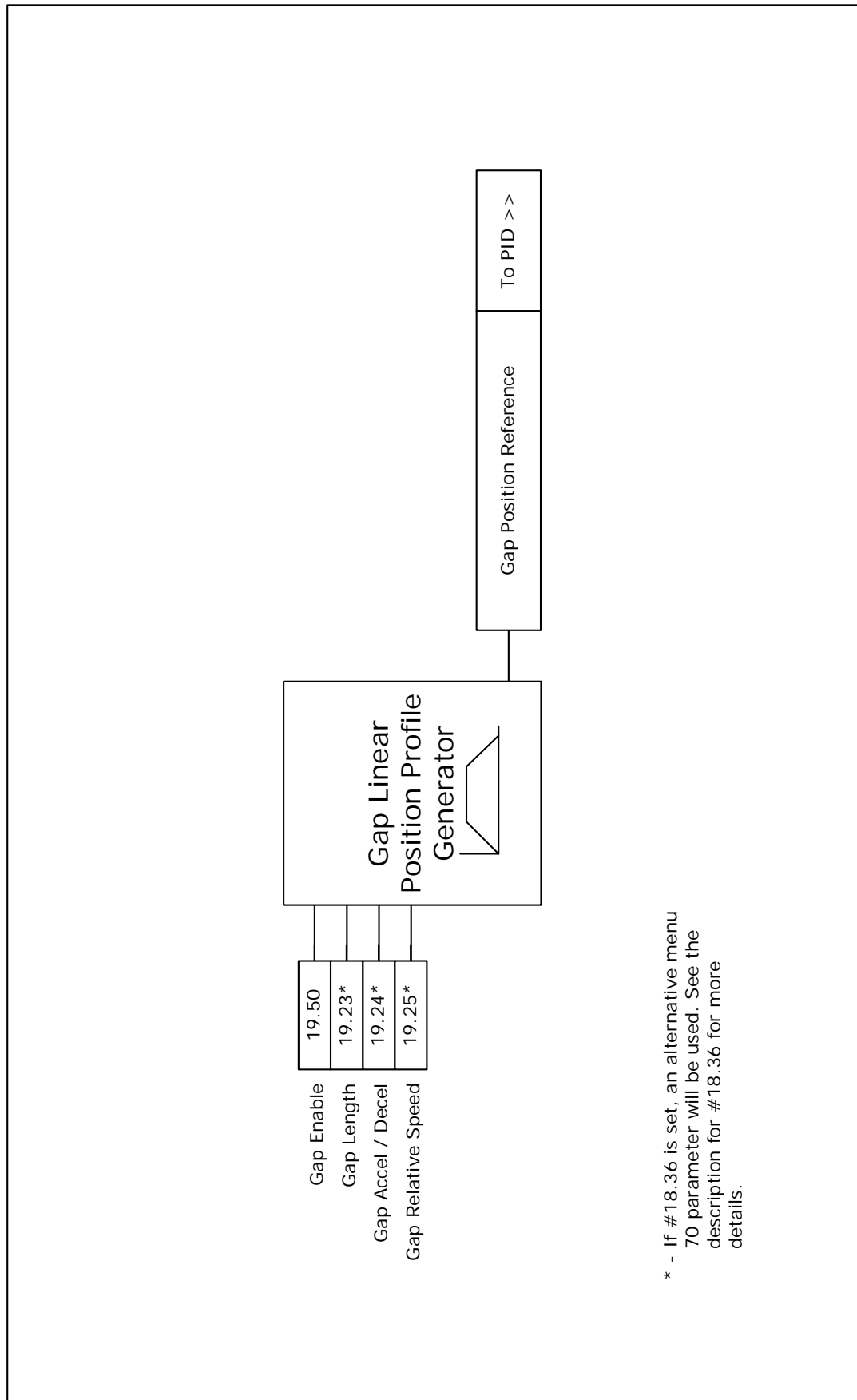

* - If #18.36 is set, an alternative menu 70 parameter will be used. See the description for #18.36 for more details.

6.8 Tool Control

For many applications the tool requires very accurate control to ensure that the flying shear profile is optimised to achieve the smallest cut length at the highest line speed. By setting the time required for performing the cut and using a high-speed output direct from the UD70 to activate the cut mechanism we can optimise the performance of the shear. The UD70 output is a TTL active low output, which requires buffering to give a usable 24volt output. To provide a fail safe system an enable signal is required to prevent the knife being activated unexpectedly if the TTL signal is lost.

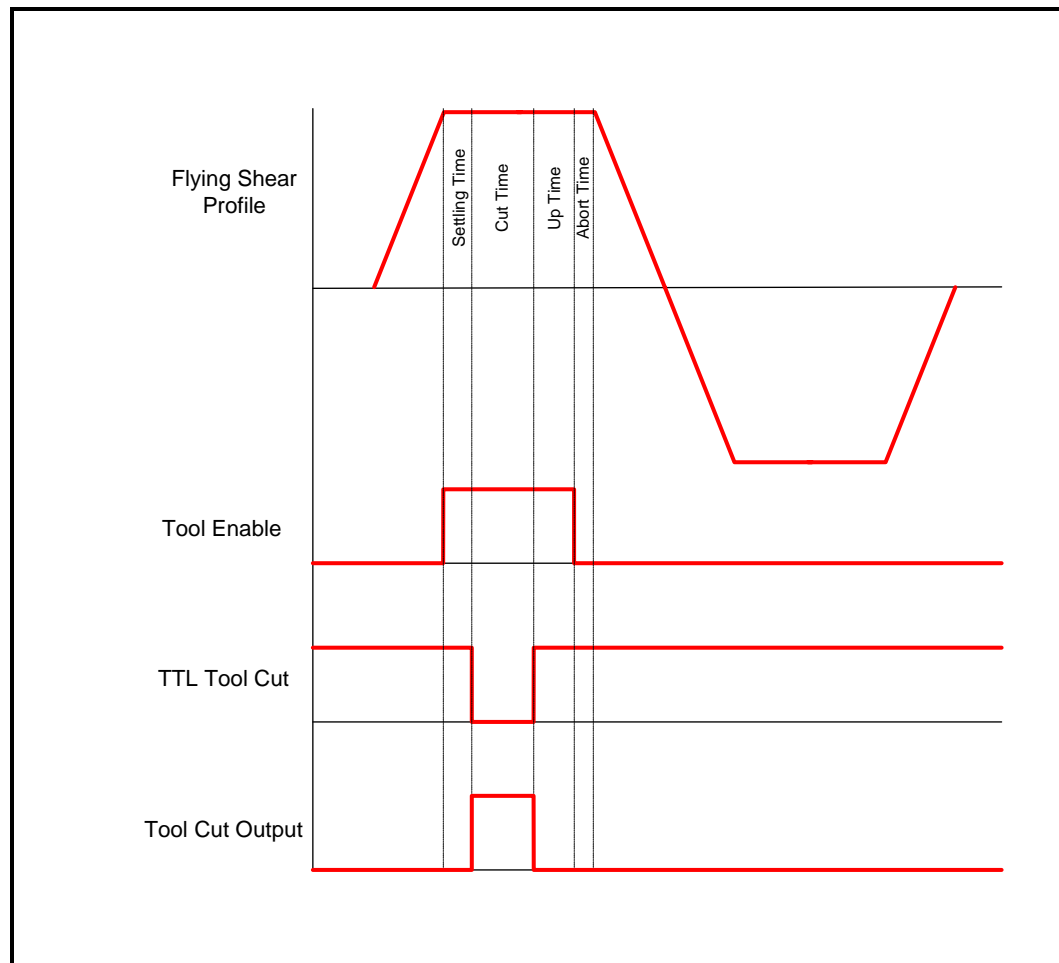
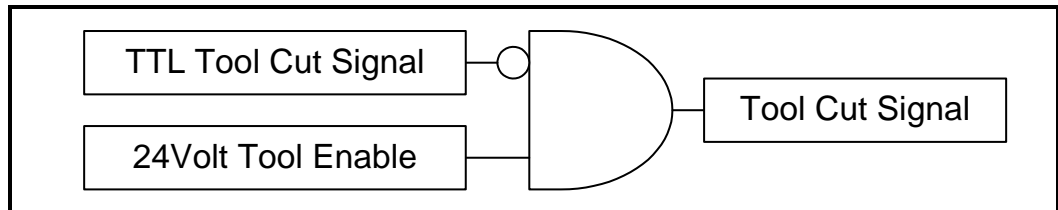

NOTE The enable signal is generated through software and therefore cannot be relied upon to prevent injury to persons working on or around the machine. It is mandatory for a hardware safety circuit to be implemented to electrically isolate the moving parts to provide a safe environment.

6.8.1 Cutter Modes

The cut mode (19.26) allows the user to select one of four cutter modes:

Mode 0

The cut output is switched on during the cut segment of the flying shear, and off at any other time. The tool up / down inputs are not used, and so the system will not detect that the tool is jammed in the product.

Mode 1

The cut output is switched on during the cut segment of the flying shear, and off at any other time. The tool up signal is used to detect that the tool is up at the end of the synchronised period, this can be used to synchronise the shear with the master for an extended period, and initiate a line stop, or alternatively can be used to flag an error or trip the drive (see Tool Sync Enable (18.33)). In this mode if the Tool Up signal is not present before shear run is enabled (19.33 = 1), then the shear will not run.

Mode 2

The cut output is switched on at the start of the cut segment of the flying shear, and off as soon as the tool down signal is received. If by the end of the flying shear cut segment the tool down signal has not received, then the tool output is switched off anyway and an error condition is set, which can be used to alarm or trip the drive . If the Tool down signal is still on at profile segment 5, then the drive will behave the same as if a tool up signal is not received, i.e. depending on how Tool Sync Enable is set. This mode is not available when Angled shear is selected.

Mode 3

This is the same as Mode 1 and mode 2 together. This mode is not available when Angled shear is selected. In this mode if the Tool Up signal is not present before the shear run is enabled (19.33 = 1), then the shear will not run.

6.8.2 Real Time Cut

When real time cut is enabled (18.50=1), the tool cut time (20.30) is set in real time, in milliseconds, and is not influenced by the line speed. The tool is fired at the beginning of profile point 3 (see shear profile diagram, section 6.5).

When real time cut is disabled (18.50=0), the tool cut time (20.30) is only applicable when the line is running at the maximum master velocity (20.28). The cut time will increase inversely proportional with line speed e.g. If the maximum master velocity (20.28) = 100 Units / s and the cut time (20.30) = 100ms, at maximum line speed the cut time is 100ms, and at half maximum line speed the cut time is 200ms.

6.8.3 Start Cut Mode

If start cut is set (19.27=1), then the flying shear will always perform an initial cut when shear run is enabled (19.33 = 1), this is so that any scrap can be removed, and can be used to ensure that the first cut is of the correct length.

6.8.4 Manual Cut / Scrap Cut

To perform a manual / scrap cut, set parameter 19.31 or control word bit 13 (73.70). When the master is at standstill setting the manual cut bit will immediately fire the tool, however, if the master is moving and the shear is in cyclic mode, the shear will synchronise to the material, and then perform the scrap cut.

Scrap cutting with a moving master can only be performed in cyclic mode.

6.8.5 Firing the tool at a specific position

To make the tool fire at a specific position along the shear travel the following method may be used:

1. Measure the distance from the knife starting position, to the point on the shear travel where the tool must be fired, in units.
2. Select fast optimisation, Pr 20.40 = 1.
3. Calculate the distance used with the current acceleration rates to get up to the maximum master velocity using the following formula:

$$\text{Acceleration Distance (units)} = (\text{Pr20.28}^2) / (2 * \text{Pr20.26})$$

The calculated acceleration distance must be equal to or less than the distance measured in step 1; if the distance calculated is longer, increase Pr20.26.

4. Calculate the settling time using the following formula:

$$\text{Settling Time (Pr20.29)} = (\text{Distance step 1} - \text{Distance step 3}) / \text{Pr20.28}$$

Enter the new settling time value in to Pr20.29

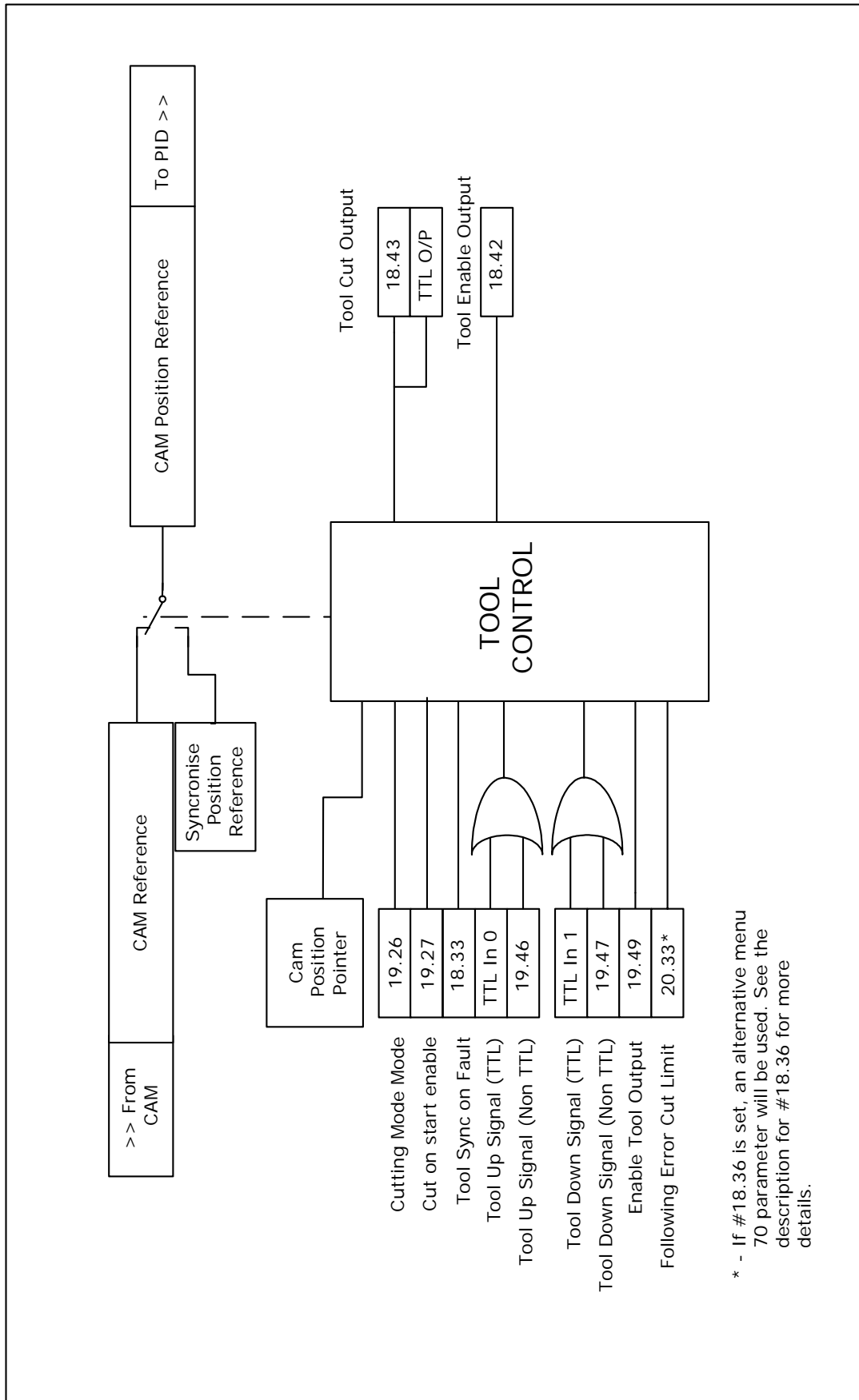

* - If #18.36 is set, an alternative menu 70 parameter will be used. See the description for #18.36 for more details.

6.9 Reference Selection and PID

The reference is selected automatically by the sequencing.

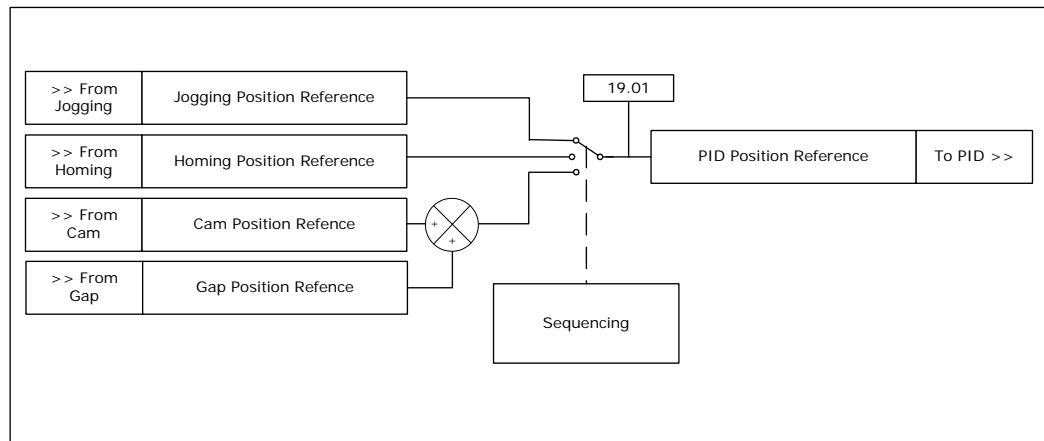

The position loop encompasses a Proportional (P) and Velocity Feed Forward (VFF) terms, in dynamic position loops such as flying shears integral and differential gains do not offer any benefits. The VFF gain is calculated so that it will produce the correct values if the gain is set to 1000, any other value will give a steady state error. The proportional gain will require tuning to achieve the best response for the mechanical system.

6.9.1 Tuning Procedure

1. Tune the speed and current loop gains to the required profile acceleration rates and cycles. Use the profile for the shortest cut at the maximum allowable line speed.

Current Loop Parameters: Proportional Gain 4.13
Integral Gain 4.14

Speed Loop Parameters: Proportional Gain 3.10
Integral Gain 3.11
Differential Gain 3.12

Refer to Unidrive documentation for further information and/or use Unisoft gain calculator wizard to determine the optimum gains.

2. Tune the position Loop.
 - a. Velocity feed-forward gain - this derives the rate of change of position reference. This is set in fixed-point integer where 1000 = 1.000.
 - i. Set to 1000, if the motor encoder is used.
 - ii. Set to the gearbox ratio multiplied by 1000, if the auxiliary encoder is used.

With the proportional gain set to 0 and the velocity feed-forward gain set correct, this can be used to tune the speed loop gains as it provides the required speed profile reference generated from the CAM, with no positional correction from the proportional term.

NOTE Without a Proportional term, an accumulative position error will occur, so care must be taken if this method of tuning of the speed loops is used as the end limits may be exceeded.

- b. Proportional gain - this provides the amount of position correction from the position error. This is set in fixed-point integer where $1000 = 1.000$. For an error of 1 encoder count and a proportional gain of 1000, there will be an output of 1 count per second.
- c. Proportional Output Limit - the proportional output is summed with the velocity feed-forward output, the amount of proportional output correction applied to the velocity feed-forward is limited by parameter 19.16, nominally this set between 1 and 20%, dependant on the application. If set too low a following error will accumulate and will effect the deceleration or end of the profile, and may also trip the drive on Tr81.

To help tune the system a scope should be used connected to analog outputs 1 & 2.

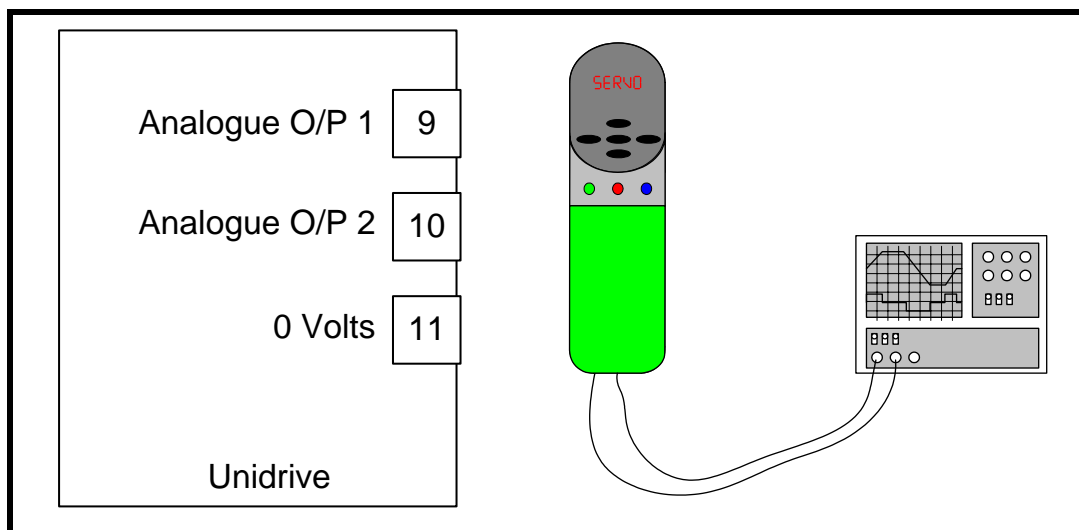

Analog output 1 can be set to give following error and analog output 2 set to give the speed profile of the flying shear.

The speed and current can be sourced to the analog on a fast update by setting parameter 07.30 = 1, (refer to user manual). The following error analog update will be slower, max 8ms).

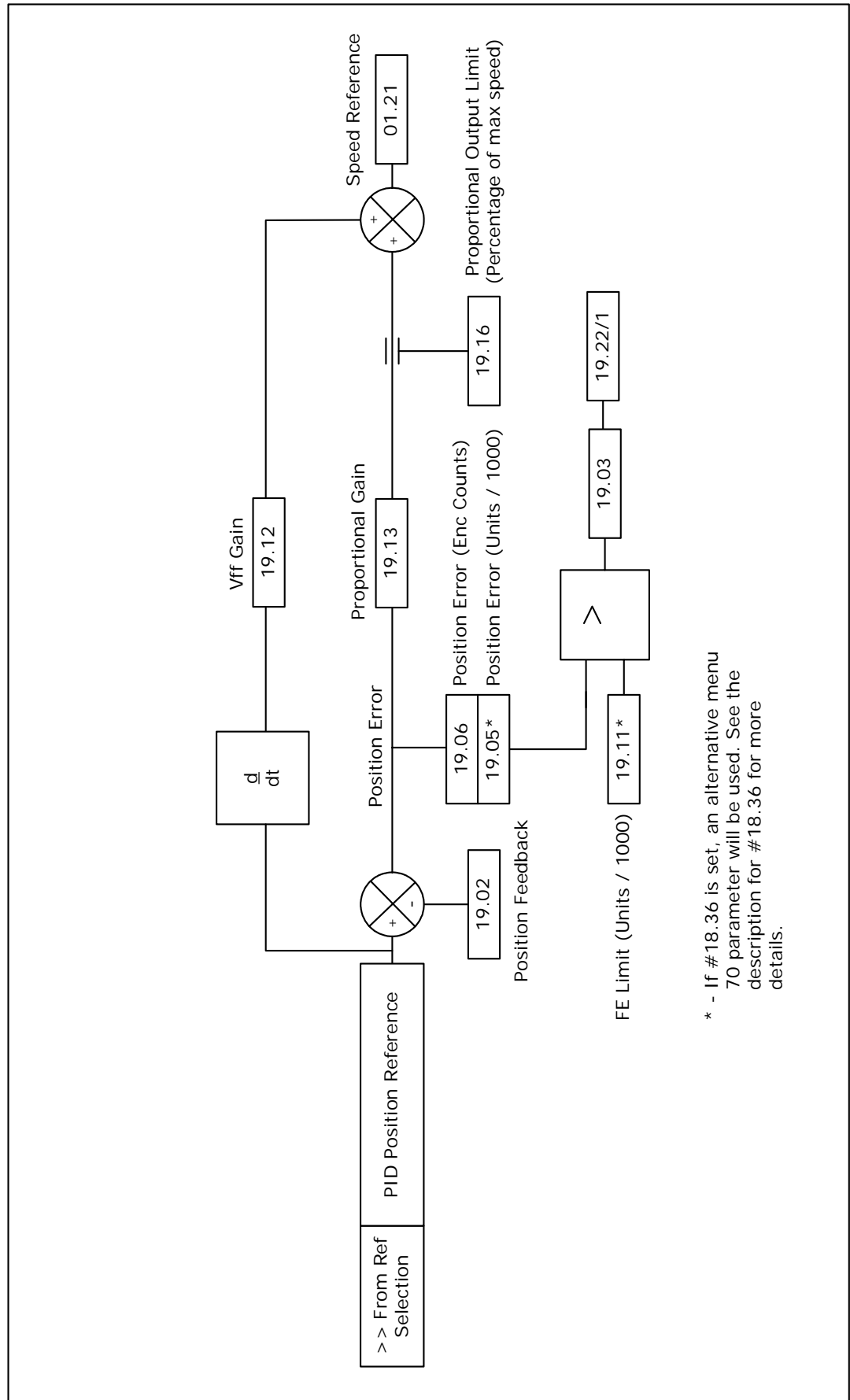

* - If #18.36 is set, an alternative menu 70 parameter will be used. See the description for #18.36 for more details.

6.10 Hardware and Software Limits / Positions

NOTE A risk assessment should be carried out to determine the potential risk of injury to persons caused by the flying shear drive losing control, if any risk exists then the standard hardware and software limits are not suitable. An external safety circuit should be used that utilises built-in redundancy to detect a potential hazard and automatically mechanically brake the flying shear safely.

The Hardware and software limits will override any other flying shear functions, and will initiate a flying shear deceleration. This is controlled by fast ramp enable (18.48); if 18.48 = 0 then the shear will stop instantaneously / Shear pin, if 18.48 = 1 then the shear will stop at the fast decel rate (20.34). It will also cause an alarm in parameter 19.22, this may be used to trip the drive, or cause an alarm.

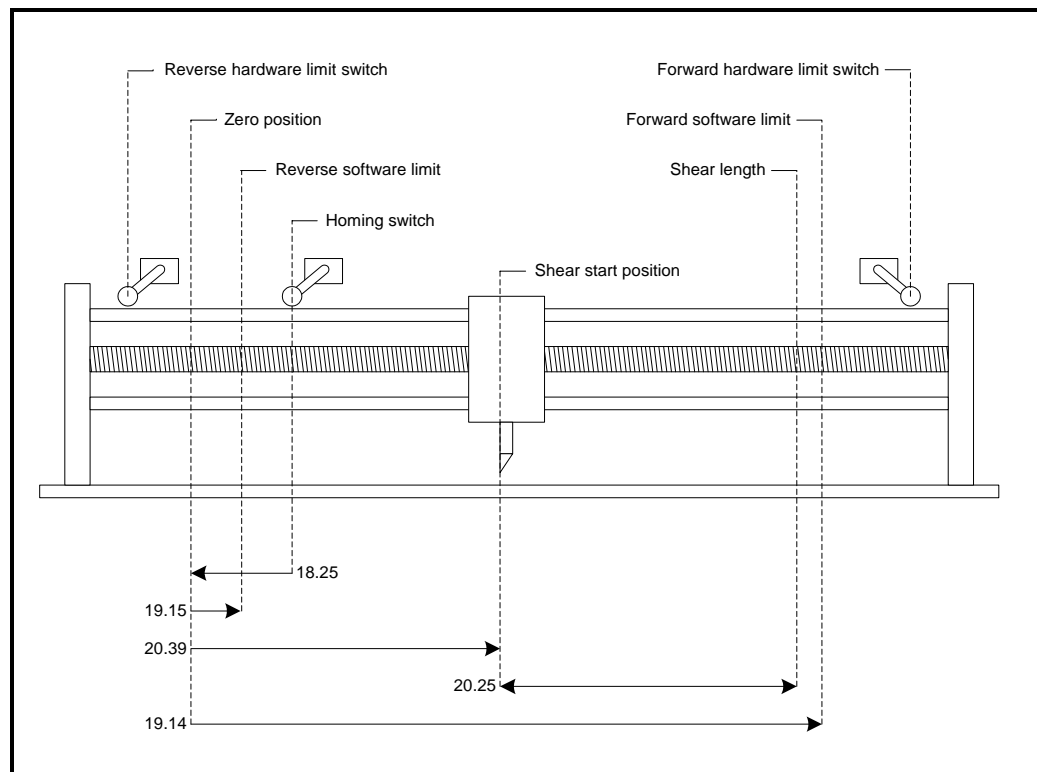

Example setup 1:

- 18.25 = 200 Units
- 19.15 = 100 Units
- 20.39 = 500 Units
- 20.25 = 500 Units
- 19.14 = 1050 Units

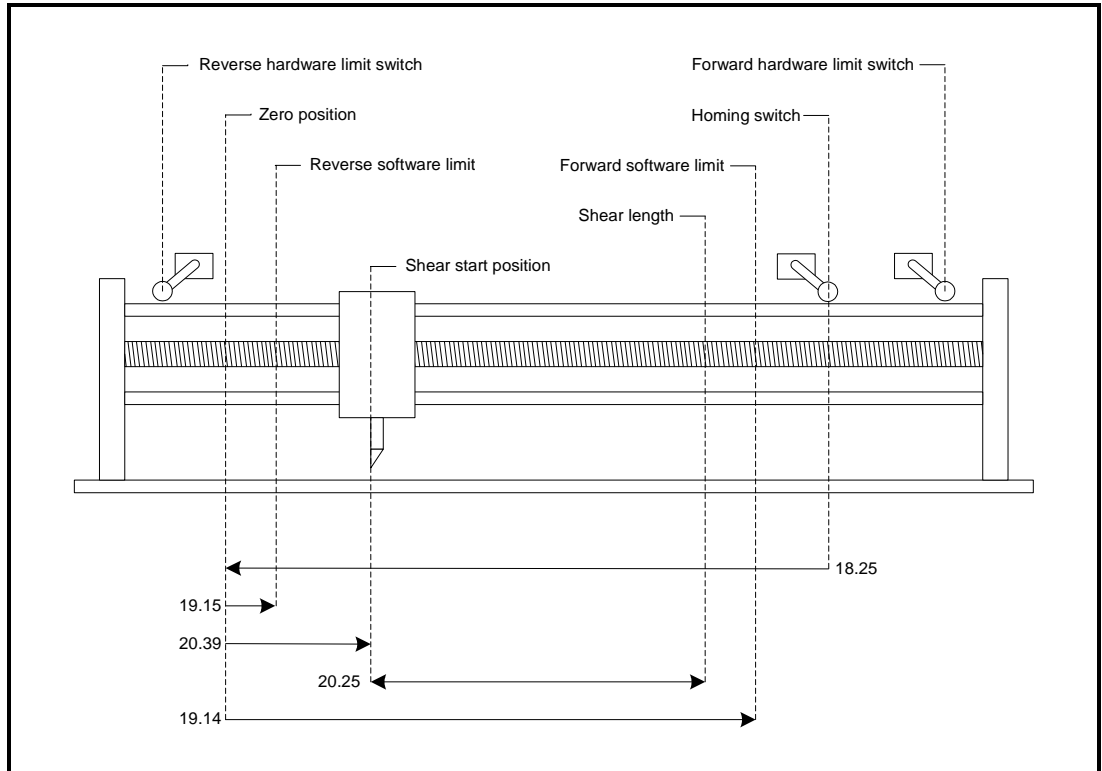

Example setup 2:

18.25 = 1000 Units

19.15 = 100 Units

20.39 = 300 Units

20.25 = 500 Units

19.14 = 900 Units

S

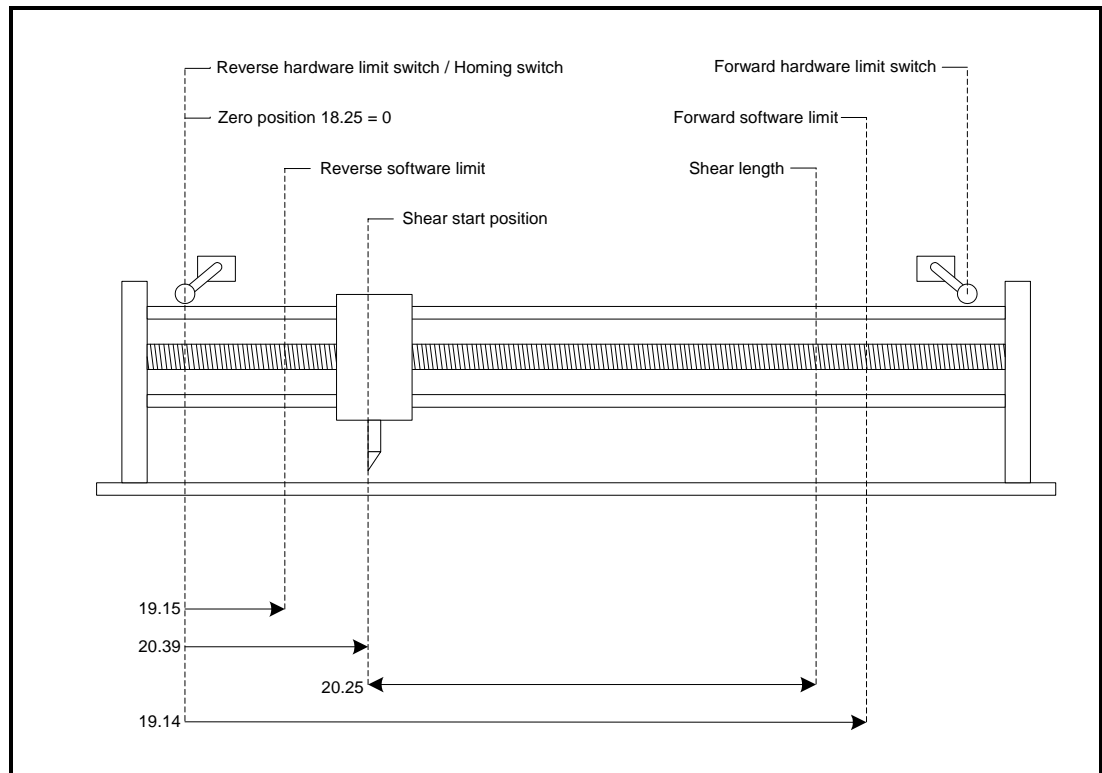

Example setup 3:

- 18.25 = 0 Units
- 19.15 = 200 Units
- 20.39 = 400 Units
- 20.25 = 600 Units
- 19.14 = 1050 Units

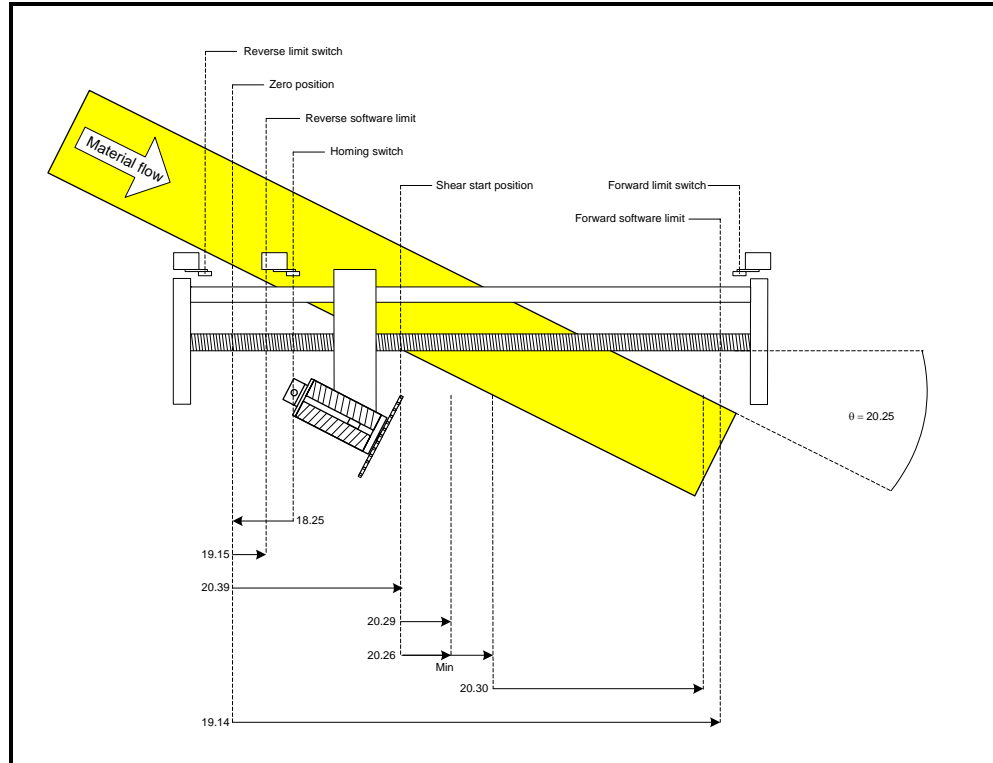

Example setup 4:

- 18.25 = 170 Units
- 19.15 = 90 Units
- 20.39 = 400 Units
- 20.25 = 3000 = 30.00 Degrees
- 20.29 = 110 Units
- 20.26 = 200 Units
- 20.30 = 500 Units
- 19.14 = 1150 Units

6.10.1 Hardware Limits

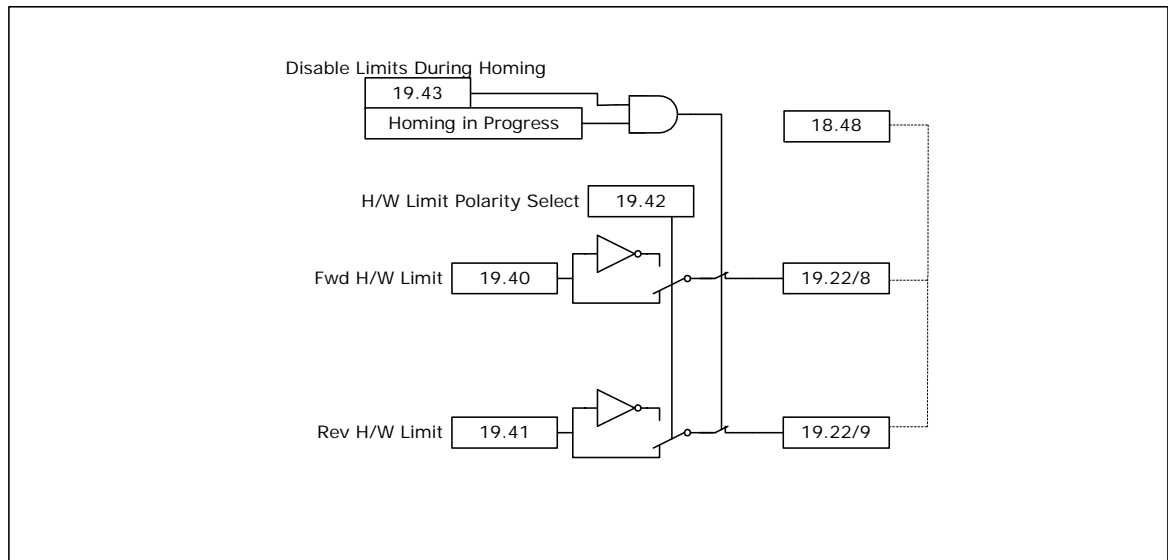

6.10.2 Software Limits

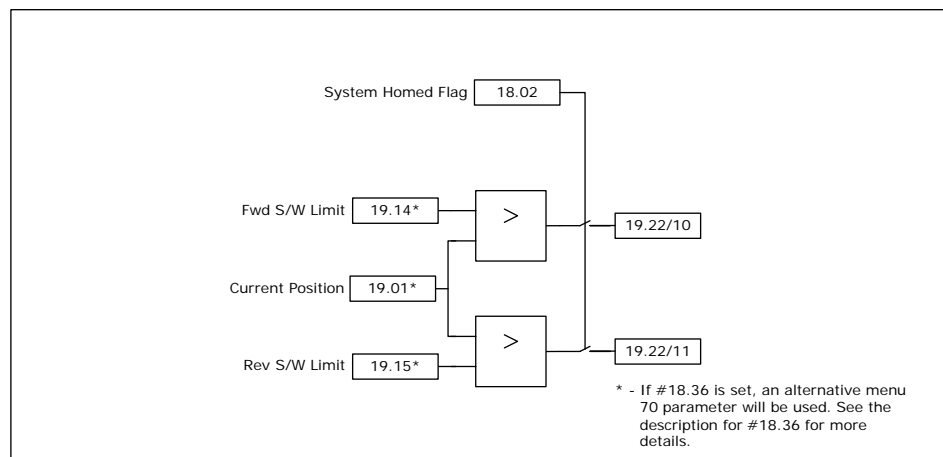

NOTE The software limits are only active after the homing sequence has been completed.

6.11 Communications Watchdog

The Watchdog is used to provide a mechanism to ensure safe operation when movement is being controlled from a remote device. The watchdog checks that the remote device is online and capable of both sending and receiving data. This is done by sending a clock signal to the remote device, which responds by resending the same clock signal back, the returned signal is then monitored to make sure that the received data is of similar clock period to the sent data.

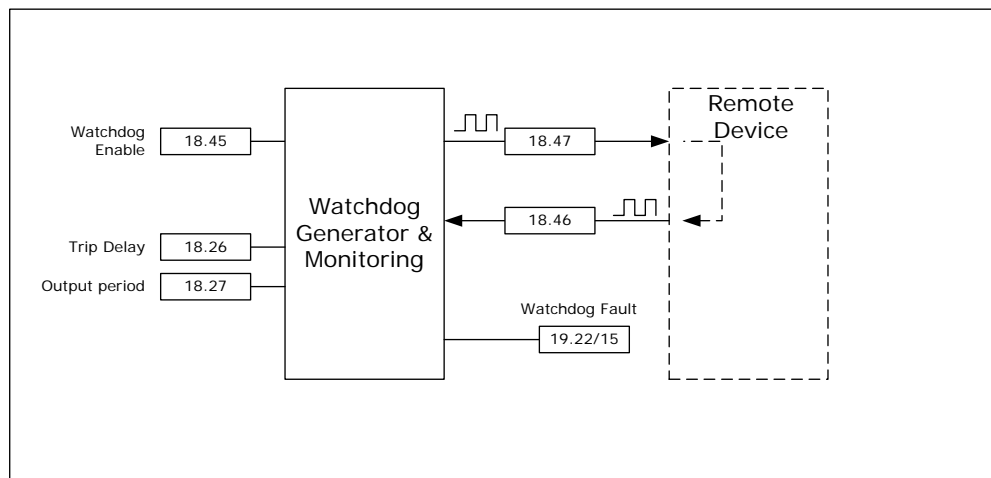

6.12 Fault Handling

The Flying Shear fault handling scheme, may be monitored and adjusted with the following parameters:

Parameter 19.18 is the Alarm word. This is a 14 bit word which indicates the status of the alarms; a bit at 1 indicates an alarm is active e.g. if bit 4 is 1 then there is a cam calculation alarm. See list below for individual bit functions.

Parameter 19.19 is the Alarm / Trip mask word. This is a 14 bit word which selects whether an alarm should trip the drive; a bit at 1 indicates that particular alarm is active, and will trip the drive e.g. if bit 4 is 1 then if there is a cam calculation alarm the drive will trip. See list below for individual bit functions.

Parameter 19.20 is the Trip conditional select word. This is a 14 bit word which selects when the drive should trip under fault conditions; a bit at 1 indicates that a trip will occur immediately, a bit at 0 indicates that the drive will trip on that particular fault at the end of the current profile cycle e.g. if bit 4 is 1 then the drive will trip immediately if a cam calculation fault occurs. See list below for individual bit functions.

Parameter 19.21 is the Alarm / Trip Enable mask. This is a 14 bit word which enables whether a fault should trigger an alarm or drive trip. A bit at 1 indicates an Alarm / Trip is active, a bit at 0 indicates an Alarm / Trip is inactive e.g. if bit 4 is 1 then a cam calculation fault is enabled to trigger an Alarm or Trip. See list below for individual bit functions.

Parameter 19.22 is the Raw Alarm Word. This is a 14 bit word which is used to generate the above parameters; a bit at 1 indicates a fault is active e.g. if bit 4 is 1 then there is a cam calculation fault. See list below for individual bit functions.

Bit functions

- Bit 0 - Tool did not rise at the end of the cycle – alarm only
- Bit 1 - Following Error Outside Limit
- Bit 2 - Other tool error
- Bit 3 - Start-up cut not done as master not stationary
- Bit 4 - Cam calculation parameter fault
- Bit 5 - Master Speed too fast
- Bit 6 - Sequence abort parameter fault
- Bit 7 - Homing Fault
- Bit 8 - Fwd H/W Lim
- Bit 9 - Rev H/W Lim
- Bit 10 - Fwd S/W Lim
- Bit 11 - Rev S/W Lim
- Bit 12 - Remote Fieldbus Trip
- Bit 13 - Watchdog fault error

When these parameters, 19.18 to 19.22, are viewed from the drives display, the decimal equivalent will be shown e.g. bit 4 will be shown as 16 (2^4).

To reset an Alarm / Trip, first remove the cause of the trip, then toggle 19.32 (0 – 1 – 0). Parameter 19.32 performs an application reset together with a drive reset.

NOTE Pressing the red reset button on the drive will only reset drive trips, it will not perform an application reset e.g. If a hardware or software limit has been reached, you will be able jog off the limit and re-home the system, but until the alarm has been reset (19.32 = 1), you will not be able to start the shear.

6.13 Start / Stop Logic

Start / Stop logic flow diagram

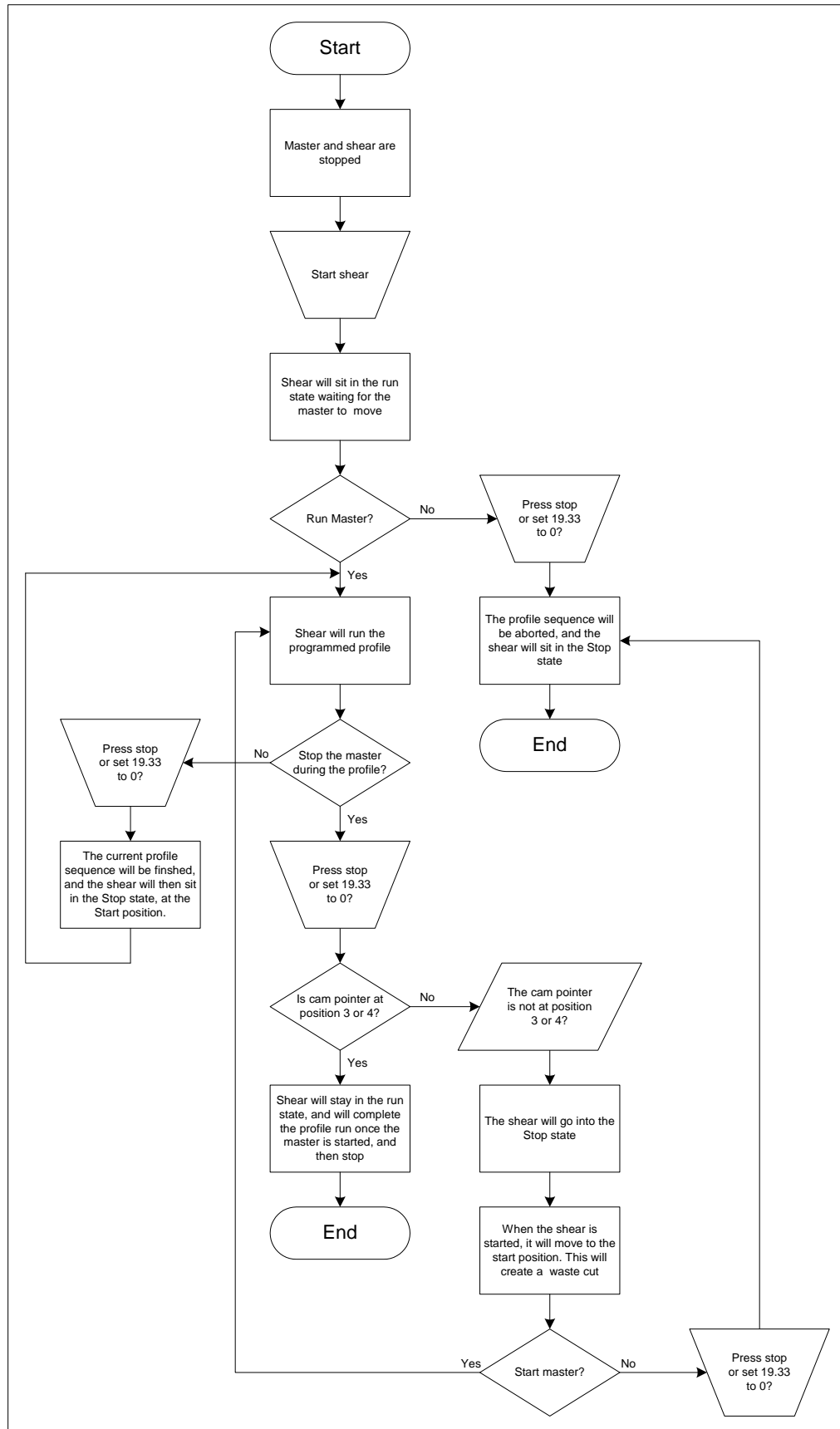

6.14 Interlocks

The flying shear software contains several interlocks to prevent damage occurring to the tool. If you are trying to perform a Jog, Home, Go To Start or Run, and you can not: the following lists detail the interlocks which need to be true before the action can be performed.

Jog Interlocks

- Drive must be enabled and healthy (18.49 = 1)
- A flying shear profile must not be running (19.33 = 0)
- The shear must not be homing (19.38 = 0)
- A Go To Start must not be in progress (19.34 = 0)
- A Sequence Abort must not be selected (19.34 = 0)
- A manual cut must not be selected (19.31 = 0)
- If tool control mode 19.26 is at 1 or 3 then the tool must be up

Home Interlocks

- Drive must be enabled and healthy (18.49 = 1)
- A flying shear profile must not be running (19.33 = 0)
- The shear must not be Jogging (19.36 = 0 and 19.37 = 0)
- A Go To Start must not be in progress (19.34 = 0)
- A Sequence Abort must not be selected (19.34 = 0)
- A manual cut must not be selected (19.31 = 0)
- If tool control mode 19.26 is at 1 or 3 then the tool must be up
- There must not be a homing fault (18.01 = a negative value)

Go To Start Position Interlocks

- Drive must be enabled and healthy (18.49 = 1)
- A flying shear profile must not be running (19.33 = 0)
- The shear must not be Jogging (19.36 = 0 and 19.37 = 0)
- The shear must not be on a software / hardware limit (check 19.22)
- A Sequence Abort must not be selected (19.34 = 0)
- A manual cut must not be selected (19.31 = 0)
- If tool control mode 19.26 is at 1 or 3 then the tool must be up
- The shear must be homed (19.07 bit 4 = 1)

Run Interlocks

- Drive must be enabled and healthy (18.49 = 1)
- A flying shear profile must not be running (19.33 = 0)
- The shear must not be Jogging (19.36 = 0 and 19.37 = 0)
- The shear must not be on a software / hardware limit (check 19.22)
- A Sequence Abort must not be selected (19.34 = 0)
- A manual cut must not be selected (19.31 = 0)
- If tool control mode 19.26 is at 1 or 3 then the tool must be up
- A Go To Start must not be in progress (19.34 = 0)
- The shear must be homed (19.07 bit 4 = 1)

6.15 Batch and Master Control

6.15.1 Batch control

The flying shear software incorporates a batch counter, with the following functions:

Batch Enable (18.16):

This enables batch control when set to 1

Batch Quantity (18.17):

This sets the number of cuts in a batch, from 1 to 32767.

Batch Reset (18.38):

This resets the batch counters, both up (18.04) and down (18.05), and also resets the Batch flags, Last Cut (18.41) and Batch done (18.06). Batch reset must be toggled (18.38= 0 – 1 – 0) to fully reset, and re-enable the batch counter; if the batch reset is just set from 0 to 1 the flags and counters will all be reset, but the batch counter will not function until batch reset is set back to 0. After a batch has been completed, the shear will stop at the start position; toggling the run command (19.33 = 1 – 0 – 1), will reset the batch counters and flags.

Batch Count Up (18.04) and Down (18.05):

These count the number of cuts performed. The count is triggered by the Tool Cut Output. If Tool Enable (19.49) is not enabled (19.49=1), then the Tool Cut Output will not be triggered, and therefore the batch counter will not function.

6.15.2 Master Control

The flying shear drive is able to interlock with the master drive, and provide control signals. Three control signals are given: System Healthy, Run Command and Last Cut:

System Healthy

If the system healthy is false then there is a serious problem, the master drive should decelerate at the maximum safe rate to ensure a minimum of damage. Connecting this interlock is highly recommended.

Run

The Run signal may be used to command the master drive to run and stop, or may be used as a flying shear ready interlock. This signal is optional.

Last Cut

The last cut signal is used to indicate that the current cut will be the last, this can be used to reduce the speed of the master to a crawl until the run signal is removed, this will result in a minimum of waste production. Last cut stays on until it is reset (18.38 = 1), or until a new batch is started. This signal is optional.

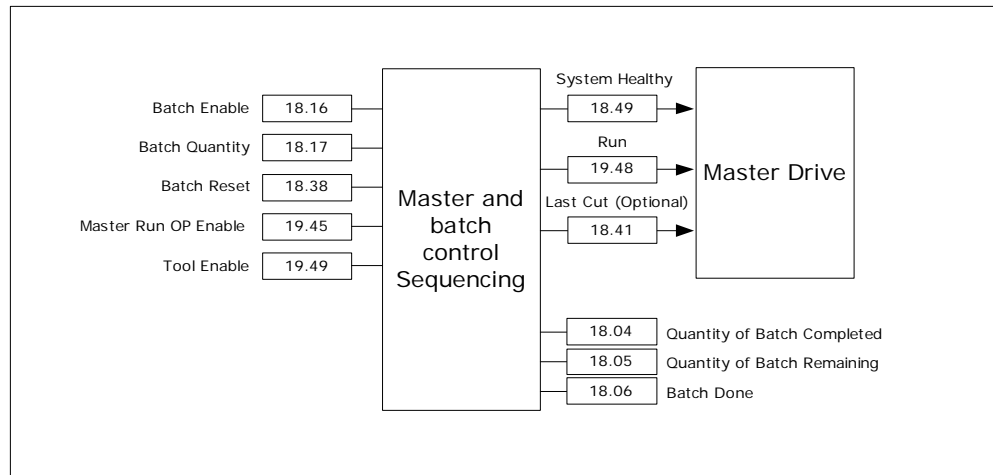

NOTE 19.49 tool control enable must be set to 1 for the batch counter to function.

7 Parameter Descriptions

7.1 Relevant Unidrive Parameters

7.1.1 Parameters set by software on power-up

17.11	Clock Task Tick Time
Application Setting	10 – 10ms

17.12	Position Loop Enable
Application Setting	12 – Run Pos loop 1.84ms time base

17.13	Application Auto Run
Application Setting	1 – Auto Run

17.14	Enable Global Trips
Application Setting	1 – Global trips enabled

17.17	Trip If Parameter Write Over-ranges
Application Setting	0 - Disabled

17.20	Auto save menu 20 parameters on power down
Application Setting	1 – auto save

20.49	Application Software Version
Application Setting	Software dependant

91.01	Fast Update Enable Key
Application Setting	3 – Enable Fast Speed Reference Update

7.1.2 Parameters set by software Permanently

1.10	Bipolar Reference Select
Application Setting	1 – Bipolar Enabled

1.14	Reference select
Application Setting	3 – Preset References

1.15	Preset Select
Application Setting	1 – Select 1.21 as reference

2.02	Enable Ramps
Application Setting	0 – Disable Ramps

2.04	Decel Ramp Mode
Application Setting	1 – Fast Ramps

5.18	Drive Switching Frequency
Application Setting	4.5 - 9Khz

6.01	Stopping Ramps
Application Setting	2 – stop without ramps

6.04	Sequencing Mode
Application Setting	4 – Wire-proof PLC Mode

6.15	Drive Enable
Application Setting	Software Dependent

6.30	Sequencing Bit 0 (Run Forward)
Application Setting	Software Dependant

91.05	Full Scale Speed
Application Setting	Parameter 1.06

7.1.3 Drive Parameters set after a default (18.44 = 1)

8.10	T24 Digital I/O 1 Source / Destination
Application Setting	19.48 – Flying Shear Running

8.12	T24 Digital I/O 1 Output Select
Application Setting	1- Output

8.13	T25 Digital I/O 2 Source / Destination
Application Setting	19.49 – Tool Enable Output

8.15	T25 Digital I/O 2 Output Select
Application Setting	1 - Output

8.16	T26 Digital I/O 3 Source / Destination
Application Setting	19.33 – Flying shear run input

8.18	T26 Digital I/O 3 Output Select
Application Setting	0 - Input

8.19	T27 Digital I/P 4 Destination
Application Setting	18.32 – Home Switch Input

8.21	T28 Digital I/P 5 Destination
Application Setting	19.40 – Forward Hardware Limit

8.23	T29 Digital I/P 6 Destination
Application Setting	19.41 – Reverse Hardware Limit

8.25	Drive Relay Output Source
Application Setting	18.49 – Flying Shear Healthy

12.03	Threshold 1 Source
Application Setting	7.02 – Analog input 2

12.04	Threshold 1 Threshold
Application Setting	50 – 50%

12.05	Threshold 1 Hysteresis
Application Setting	1 – 1%

12.07	Threshold 1 Destination
Application Setting	19.38

If a Second Encoder (UD51) is fitted then:

16.10	Freeze Input Enable
Application Setting	1 – 1 Freeze Input Enabled

Application Parameters

7.1.4 Menu 18

18.01 Home State	
Coding	RO, Bi
Range:	-3 to 5
Units:	List

This indicates the condition of the Home Sequence

- 0 = STOP state
- 1 = Initialise
- 2 = Search for Home state
- 3 = Home detection state
- 4 = Position Offset state
- 5 = Preset final Home position/Completion state

ERROR States less than 0

- 1 = Home disabled during home sequence
- 2 = Home time exceeded timeout
- 3 = Drive not Enabled

18.02 Home Complete	
Coding	RO, Bit

If set this parameter indicates that the home sequence has been completed.

18.03 Scan Time	
Coding	RO, Uni
Range:	1 to 500
Units:	ms

Indicates the scan time of the Background task in ms.

18.04 Batch Counter (Count UP)	
Coding	RO, Uni
Range:	0 – 18.17
Units:	Qty

Batch Counter, indicates the number of cut cycles completed.

18.05 Batch Counter (Count DOWN)	
Coding	RO, Uni
Range:	18.17 - 0
Units:	Qty

Indicates the quantity remaining in the batch.

18.06	Batch Done
Coding	RO, Bit

Indicates that the current batch is completed.

18.07	Minimum Registration Distance
Coding	RO, Units

Indicates the minimum distance the registration sensor can be away from the tool start position (material edge in angled shear mode). Add 10% to this distance to make sure the profile can be met. 20.43 is limited to a minimum of this value.

18.08	Length of Last Cut 1
Coding	RO, Uni
Range:	0 - 32000
Units:	Units

Indicates the length of the last cut.

18.09	Length of Cut before Last Cut
Coding	RO, Uni
Range:	0 - 32000
Units:	Units

Indicates the length of the cut before the last cut 18.08.

18.10	Line Speed Indication
Coding	RO, Uni
Range:	±32000
Units:	Units/(min*18.18)

This parameter indicates the line speed in selected units per min. The units can be scaled with the line speed scalar parameter 18.18.

$18.10 = \text{Selected Units} (18.11/18.12) / 18.18$

Example:

- a. To display metres/min when the selected units are in millimetre set parameter
18.18 = 1000.
- b. To display feet/min when the selected units are in 0.1inches set parameter
18.18 = 120.

NOTE This parameter is filtered to produce a steady indication of speed.

18.11 Units	
Coding	RW, Uni
Range:	0 to 9
Default settings:	0
Units:	List

The CTIU uses this parameter to store the units that are selected by the CTIU configuration. This parameter does not make any difference to the operation of the flying shear, and is simply used as a non-volatile memory for the display.

- 0 = Undefined User units
- 1 = mm x 100
- 2 = mm x 10
- 3 = mm
- 4 = mm / 10
- 5 = mm / 100
- 6 = inches x 10
- 7 = inches
- 8 = inches / 10
- 9 = inches / 100

18.12 Master Scaling Denominator	
Coding	RW, Uni
Range:	1 to 32000
Default settings:	1
Units:	Units

Master encoder feedback scaling denominator.

NOTE This parameter is only read on power up and when update scaling (parameter 18.37) is set to 1.

18.13 Master Scaling Numerator	
Coding	RW, Uni
Range:	1 to 32000
Default settings:	16384
Units:	Counts

Master encoder feedback scaling numerator.

NOTE This parameter is only read on power up and when update scaling (parameter 18.37) is set to 1.

18.14 Slave Scaling Denominator	
Coding	RW, Uni
Range:	1 to 32000
Default settings:	1
Units:	Units

Slave encoder feedback scaling denominator.

NOTE This parameter is only read on power up and when update scaling (parameter 18.37) is set to 1.

18.15 Slave Scaling Numerator	
Coding	RW, Uni
Range:	1 to 32000
Default settings:	16384
Units:	Counts

Slave encoder feedback scaling numerator.

NOTE This parameter is only read on power up and when update scaling (parameter 18.37) is set to 1.

18.16 Enable Batch Control	
Coding	RW, Bit
Default settings:	0

Set to enable batch control to be used.

18.17 Batch Quantity	
Coding	RW, Uni
Range:	0 – 32000
Default settings:	10
Units:	Qty

Quantity in a batch.

18.18 Line Speed Scalar	
Coding	RW, Uni
Range:	1 – 32000
Default settings:	1000
Units:	Scale

Refer to parameter 18.10.

18.19 Home Speed	
Coding	RW, Uni
Range:	0 – * see parameter description below
Default settings:	5
Units:	Units / s

This parameter sets the speed that the home sequence will search for the home switch.

* This parameter is limited by the max. speed of the drive which is converted to Units/sec, and it is derived as follows:

$$\text{Max Speed Limit (Units/s)} = (01.06 * 03.21 * 4 * 18.14 * 0.99) / (60 * 18.15).$$

The Max speed limit is 99% of the drive max speed, to allow some small margin for positional correction, if required.

18.20 Home Mode	
Coding	RW, bit
Default settings:	0

This parameter determines the homing mode as follows:

0 – Home to the leading edge of home/limit switch

1 – Search for the leading edge of home/limit switch and home on next encoder marker pulse.

NOTE Mode 1 is not possible with SinCos or Resolver feedbacks.

18.21 Home Back-off Speed	
Coding	RW, U
Range:	0 – * see description in parameter 18.19
Default settings:	1
Units:	Percentage of 18.19

This parameter set the speed that the axis will back-off the Home / Datum switch.

18.22 Home Search Direction	
Coding	RW, Bit
Default settings:	0

This set the initial direction for searching for the home.

1 = Forwards

0 = Reverse

18.23 Home Acceleration / Deceleration	
Coding	RW, U
Range:	0 – 32000
Default settings:	50
Units:	Units / s ²

This parameter defines the acceleration and deceleration ramps for the homing sequence.

18.24 Home Time	
Coding	RW, Uni
Range:	0 – 32000
Default settings:	500
Units:	0.01 Seconds

This parameter defines the time allowed for the homing sequence to complete.

18.25 Zero Position Preset	
Coding	RW, Uni
Range:	0 – 32000
Default settings:	0
Units:	Units

This parameter sets the zero position for this axis. This distance is added in a negative direction to the Home / Datum position.

18.26 Watchdog Trip Delay	
Coding	RW, Uni
Range:	0 – 32000
Default settings:	2200
Units:	ms

18.27 Watchdog Out Time Period	
Coding	RW, Uni
Range:	0 – 32000
Default settings:	700
Units:	ms

The Watchdog is used for monitoring the health of a communications link.

The drive generates a clock signal with an on / off time set by parameter 18.27. The clock signal is read by the remote device, which then sends the clock signal back to the drive. If the received clock from the remote device does not change state within the time set by parameter 18.26 then a fault condition occurs. This checks the communication link is able to read and write to/from the drive.

18.28 Jog Speed	
Coding	RW, Uni
Range:	0 – * see description in parameter 18.19
Default settings:	5
Units:	Units / s

Set the jog speeds for both forward and reverse.

18.29 Jog Acceleration Rate	
Coding	RW, Uni
Range:	0 - 32000
Default settings:	100
Units:	Units / s ²

Sets the acceleration rate for the flying shear axis jog.

18.30 Jog Deceleration Rate	
Coding	RW, Uni
Range:	0 – 32000
Default settings:	100
Units:	Units / s ²

Sets the deceleration rate for the flying shear axis jog.

18.31 Home Switch Polarity	
Coding	RW, Bit
Default settings:	1

Sets the polarity of the home switch input.

1 = Normally Closed

0 = Normally Open

For safety reasons a fail-safe normally closed switch is recommended.

18.32 Home Switch Input	
Coding	RW, Bit
Default settings:	0

This parameter is used as the home switch input, if a digital input is used, then it should be written to this parameter. This parameter is controlled by Digital Input F6 from default.

18.33 Tool Sync Enable	
Coding	RW, Bit
Default settings:	0

This parameter sets the failure mode of the flying shear when the tool-raised signal is not received at the end of the normal synchronised period. There are two options:

Decelerate the flying shear, or we can stay synchronised to the master and stop the line, the choice will depend upon the risk of damage to the tool, and the ability to stop the production line within the available travel of the flying shear.

0 = Decelerate as normal (at the Jog Accel/Decel rate)

1 = Synchronise to the line

NOTE In angled shear mode (20.41 = 1) option 1 is not available, and has no effect.

18.34 Flying Shear Ready	
Coding	RO, Bit
Default settings:	0

If this parameter is set to one then the flying shear will attempt to start when parameter 19.33 is set to one.

18.35 Enable Feed Forward Term Filter	
Coding	RW, Bit
Default settings:	0

When enabled, a 40ms filter is introduced in to the speed feed forward term, which is derived from the Master encoder speed feedback. This will help to reduce motor noise in the slave when a low resolution master encoder has been fitted, or where there is a low number counts per base unit for the master compared with the slave.

NOTE Enabling 18.35 will cause a small positional following error, when the master accelerates or decelerates.

18.36 Enable High Resolution Alternative Parameters	
Coding	RW, Bit
Default settings:	0

When set to 1, alternative menu 70 (_Px%) parameters become enabled for all distance, speed and acceleration related functions. This parameter can only be changed when the drive not running i.e.when it is in the "stop" or "ready" state. The following table details the alternative paramers selected when 18.36 = 1:

Function	18.31 = 0	18.31 = 1
Home Speed	18.19	70.00
Home Accel / Decel	18.23	70.01
Zero Position Preset	18.25	70.02

Function	18.31 = 0	18.31 = 1
Jog Speed	18.28	70.03
Jog Acceleration	18.29	70.04
Jog Deceleration	18.30	70.05
Following Error Limit	19.11	70.06
Forward Software Limit	19.14	70.07
Reverse Software Limit	19.15	70.08
At Position Tolerance	19.17	70.09
Gap Length	19.23	70.10
Gap Acceleration	19.24	70.11
Gap Relative Speed	19.25	70.12
Cut Length	20.24	70.13
Master Velocity	20.28	70.14
Shear Travel Length	20.25	70.15
Profile Fly Accel / Decel Rate	20.26	70.16
Profile Return Accel / Decel Rate	20.27	70.17
Cut Following Error Limit	20.33	70.18
Fast Deceleration Rate	20.34	70.19
Virtual Master Speed	20.38	70.20
Start Position	20.39	70.21
Registration Distance	20.43	70.22
Preset Master Distance	20.47	70.23
Minimum Cut Length	20.21	70.50
Length Of Last Cut	18.08	70.51
Length Of Cut Before Last Cut	18.09	70.52
Actual Cut Length Position	19.10	70.53
Following Error	19.05	70.54
Max. Recorded Cut Following Error	19.08	70.55
Shear Travel Distance For Profile	19.09	70.56
Shear Actual Position Reference	19.01	70.57
Shear Actual Position Feedback	19.02	70.58
Minimum Registration Distance	18.07	70.60

18.37 Update Scaling

Coding	RW, Bit
Default settings:	0

This parameter is set to one to update the forward direction of the axis, the feedback source and the scaling of the axis, it will return to zero automatically when completed. This can only be performed when the shear is stopped. If 18.37 is set to 1 whilst the shear is running, the update will only be actioned when the shear is next stopped.

18.38	Batch Count Reset
Coding	RW, Bit
Default settings:	0

Resets the batch counters.

18.39	Acquire Feature Select
Coding	RW, Bit

This bit enables the Acquire feature. When 18.39 = 1, the Flying Shear system will only update the CAM motion profile profile when 18.40 transitions 0 - 1. This prevents the the CAM motion profile paramters from being updated over several cycles of the flying shear, and instead, makes sure all of the changes happen at the same time.

18.40	Acquire Bit
Coding	RW, Bit

When 18.39 = 1, and upon a 0 - 1 transition of 18.40, all of the motion profile parameters e.g. Cut Length, maximum master velocity etc, will be used to re-calculate the Flying Shear CAM profile. Bit 12 of the Control Word _S70% performs the same function.

18.41	Last Cut
Coding	RO, Bit

Indicates that the last cut in the batch is in progress, this can be used to slow the master down, to reduce the waste product produced.

18.42	Tool Output Enable
Coding	RO, Bit

This control bit is used with the UTIM interface. It ensures the tool is not activated on power up, as the application module TTL output, on/off states are the inverse to what is required.

18.43	Tool Cut Command
Coding	RO, Bit
Default settings:	0

Can be used as a source for a digital output to trigger the tool to cut the product.

18.44	Default Parameters
Coding	RW, Bit
Default settings:	0

Set to 1 to set the parameters to default.

18.45	Watchdog enable
Coding	RW, Bit
Default settings:	0

A Communications watchdog can be used to monitor the health of a communications link, the watchdog simply sends a clocked (0,1,0,1) signal to the remote device, and expects to get a similar signal returned. This parameter enables the watchdog monitoring.

18.46	Watchdog In
Coding	RO, Bit

This parameter should be written to with a toggling bit from the remote communication device, the remote device may simply send back the clock pulse that it receives from parameter 18.48.

18.47	Watchdog Out
Coding	RO, Bit

This parameter should be sent to the remote device, the parameter will toggle at a time base set by parameter 18.27

18.48	Fast Ramp Enable
Coding	RW, Bit
Default settings:	0

This parameter determines what happens when a software or hardware limit is hit or reached.

0 = Shear pin stop, this will stop the shear instantaneously (no ramp) when a limit is hit.

1 = Fast stop, this will ramp the shear to a stop when a limit is hit. The fast deceleration rate is determined by parameter 20.34

18.49	System Healthy
Coding	RO, Bit
Default settings:	0

This Parameter should be used as an interlock to stop the master, if this parameter = 0 then the flying shear is in a fault condition and the line / master should stop as quickly as possible.

18.50	Real Time Cut Enable
Coding	RW, Bit
Default settings:	0

When this parameter is set at 1, the tool cut time, 20.30, is set in real time, in milliseconds and is not influenced by the line speed. The tool is fired at the beginning of profile point 3 (see shear profile diagram, section 6.5).

When this is set at 0, 20.30 is only applicable at maximum speed. This time will increase inversely proportional with line speed e.g. If $20.28 = 100 \text{ Units / s}$ and $20.30 = 100\text{ms}$, at maximum line speed the cut time is 100ms, and at half maximum line speed the cut time is 200ms.

7.1.5 Menu 19

19.01 Shear Actual Position Reference	
Coding	RO, Bi
Range:	± 32000
Units:	Units

This parameter indicates the demand position of the flying shear axis.

19.02 Shear Actual Position Feedback	
Coding	RO, Bi
Range:	± 32000
Units:	Units

This parameter returns the actual position of the flying shear axis.

19.03 FE Active	
Coding	RO, Bit

If Set to 1, this parameter indicates that the following error is outside the following error limit, set by parameter 19.11

19.04 Master Registration Windowing Position	
Coding	RO, Bi
Range:	± 32000
Units:	Units

This parameter indicates the master position in user units, with respect to the registration windowing.

19.05 Following Error (0.001 Units)	
Coding	RO, Bi
Range:	± 32000
Units:	Units * 1000

This parameter returns the following error of the flying shear axis.

19.06 Following Error (Encoder Counts)	
Coding	RO, Uni
Range:	±32000
Units:	Encoder Counts

This parameter returns the following error, based on the number of encoder counts error for maximum resolution.

19.07 Flying Shear Status Word	
Coding	RO, Uni

This Parameter returns the current activity of the flying shear; it is coded in a bit-wise form.

Bit	Description
0	Jogging
1	Travelling To Start Position
2	At Start Position
3	Homing Sequence In Progress
4	System Homed
5	Flying Shear Cycle Running
6	Cyclic Mode Selected
7	0 = Local 1 = Remote
8	Registration Mode Selected
9	New Cam Is Being Calculated
10	Cam Is Ready
11	On Last Cut In batch
12	Batch Done
13	Shear Is Ready To Run
14	Alarm Active

NOTE When this parameter is viewed from the drive's display, the decimal equivalent will be shown e.g. bit 4 will be shown as 16 (2^4).

19.08 Max Cut FE Detected	
Coding	RO, Uni
Range:	0 to 32767
Units:	0.01 Units

This parameter shows the maximum peak cut following error detected in the previous cut cycle. The maximum value is displayed at the end of profile segment 3 (see section 6.5), and reset during segment 1 & 2. This parameter should be used to set up parameter 20.23; an upper value should be determined from several samples in 19.08, then a reasonable margin added to give headroom before entering a value in 20.23.

19.09 Shear Travel Distance For Profile	
Coding	RO, Bi
Range:	±32000
Units:	Units

This indicates how far in user units the slave axis will travel during the fly part of the cutting profile.

19.10 Actual Cut Length Position	
Coding	RO, Bi
Range:	±32000
Units:	Units

This parameter returns the actual position of the master axis, relative to the last cut point on the material.

19.11 FE Limit 0.001 Units	
Coding	RW, Uni
Range:	1 - 32000
Default settings:	100
Units:	0.001 Units

This parameter sets the allowable flowing error, before a fault condition is reported.

19.12 Velocity Feed Forward Gain	
Coding	RW, Uni
Range:	0 - 32000
Default settings:	1000
Units:	0.001Kd/sec

Assuming the feedback for the flying shear is generated from the feedback device mounted on the back of the motor, this parameter should always be set to 1000; any other value will produce a steady state following error.

19.13 Proportional Gain	
Coding	RW, Uni
Range:	0 – 32000
Default settings:	1600
Units:	0.01Kp

This parameter is the proportional gain for the position loop.

19.14 Forward Software Limit Position	
Coding	RW, Uni
Range:	0 - 32000
Default settings:	0
Units:	Units

Forward Software limit for the flying shear.

19.15 Reverse Software Limit Position	
Coding	RW, Uni
Range:	0 - 32000
Default settings:	0
Units:	Units

Reverse Software limit for the flying shear axis

19.16 Proportional Gain Output Limit	
Coding	RW, Uni
Range:	0 – 100
Default settings:	10
Units:	% of max speed (01.06)

In the position loop the feed-forward gain will give the drive approximately the correct speed reference, the proportional gain is then added to the feed-forward as a small trim to keep the axis at the correct position, The proportional gain should not need to generate any more that a fraction of the full speed of the axis, a typical value for this parameter should be between 15 – 25% of motor maximum speed set in parameter 01.06.

19.17 At Position Tolerance	
Coding	RW, Uni
Range:	0 – 32000
Default settings:	1000
Units:	Units / 1000

This defines the allowable error when the axis is in a set position.

19.18	Alarm Word
Coding	RO, Uni
19.19	Alarm / Trip Selection Mask Word
Coding	RW, Uni
Range:	0 – 16383
Default settings:	16383
19.20	Trip Conditional Select Mask Word
Coding	RW, Uni
Range:	0 – 16383
Default settings:	8064
19.21	Alarm / Trip Enable Mask
Coding	RW, Uni
Range:	0 – 16383
Default settings:	16383
19.22	Raw Alarm / Trip Data
Coding	RO, Uni

The parameters 19.18 – 19.21 are arranged with the following bit functions.

- 0 Tool did not rise at the end of the cycle – alarm only
- 1 *Following Error Outside Limit
- 2 **Other tool error
- 3 Start-up cut not done as master not stationary
- 4 Cam calculation parameter fault
- 5 Master Speed too fast
- 6 Sequence abort parameter fault
- 7 Homing Fault
- 8 Fwd H/W Limit
- 9 Rev H/W Limit
- 10 Fwd S/W Limit
- 11 Rev S/W Limit
- 12 Remote Fieldbus Trip
- 13 Watchdog fault error

*This can be: FE Limit (19.11) or Cut FE Limit (20.33)

**This can be: tool did not fire, tool is still in the product when shear is moved, or FE Cut Limit is exceeded

Parameter 19.18 is the alarm word, and gives the status of all the current alarms immediately that the alarms occur.

Parameter 19.19 selects whether the alarm should also trip the drive, set to 1 to trip the drive and alarm, set to zero for alarm only.

Parameter 19.20 allows you to select when you want the trip to occur. If set to 1 then the trip will occur at the same time as the alarm, if set to 0 then the trip will occur at the end of the current flying shear cycle.

Parameter 19.21 allows you to enable / disable alarms and trips, set to 1 to enable alarm and/or trip.

NOTE The alarms for the hardware and software limits cannot be disabled.

Parameter 19.22 contains the raw fault data that is used to generate the above parameters.

When these parameters are viewed from the drives display, the decimal equivalent will be shown e.g. bit 4 will be shown as 16 (2^4).

19.23 Gap Length	
Range:	0 – 32000
Coding	RW, Uni
Default settings:	0
Units:	Units

If Gap mode is enabled then this parameter is used to set the length of the gap. A Gap is produced between cuts, by adding a trapezoidal profile on to the cam. Length, acceleration rate and speed are required to determine the required profile.

19.24 Gap Accel	
Coding	RW, Uni
Range:	0 – 32000
Default settings:	0
Units:	Units/s ²

This parameter is used to set the acceleration and deceleration rate for the gap producing profile.

19.25 Gap Relative Speed	
Coding	RW, Uni
Range:	0 – 32000
Default settings:	0
Units:	Units/s

This parameter is used to set the relative speed for the gap producing profile. This speed + the profile speed, must not exceed the drive maximum linear speed, see section 6.7.

19.26 Cut Mode	
Coding	RW, Uni
Range:	0 – 3
Default settings:	0

The cut mode determines how the up and down inputs are used:

- 0 = Does not use tool up/down inputs for feedback
- 1 = Use cutter up input only to check that the tool is clear prior to decelerating
- 2 = Use cutter down input only to give the shear the signal when to remove the tool cut signal. If the tool down signal is not present at the end of the cut period then the tool will rise and a fault condition will be set.
- 3 = Use both up and down.

See also section 6.8

NOTE In Angled Shear only modes 0 and 1 are available. If a tool up error is detected, at the end of a cut, the shear will stop before the return part of the cycle (Cam point 6) can happen. For this reason it is important to leave extra cut length to make sure the tool is clear of the material when a fault is detected, otherwise the tool may be damaged.

19.27 Cut on start of Shear Cycle	
Coding	RW, Bit
Range:	0 – 1
Default settings:	0

If this input is set to one then the shear will always perform an initial cut prior to going into run mode, this is so that the first cut can be of the correct length. This function is not available in Angled Shear mode (20.41 = 1).

19.30 First Cut Mode	
Coding	RW, Uni
Range:	0 – 3
Default settings:	0

This parameter is used to define how the first cut is performed when the flying shear is operating in cyclic mode. This may be used to ensure that the first cut is of the correct length, and therefore eliminate any waste caused by the first cut.

- 0 = Cut Immediately (don't worry about waste).
- 1 = Use registration once only to detect product edge, and cut one length later.
- 2 = Cut after a dwell of one cut length, this is used when the product starts off aligned to the cutting tool.

19.31 Manual Tool Cut Command	
Coding	RW, Bit
Default settings:	0

Perform a manual cut when the master axis is stationary, or perform a scrap cut when the shear is running. If the master is stopped, the tool will be fired immediately, however if the line is moving and cyclic mode is selected, the shear will start immediately synchronise to the line, and then perform a cut.

A scrap cut can only be done with a moving master, when the shear is set to cyclic mode and the fast optimisation mode is set (20.40).

Ensure that interlocks are present to prevent injury to persons.

19.32 Drive / Fault Reset	
Coding	RO, Bit
Default settings:	0

This parameter is the global reset, and will perform the same function as the drive reset button, and it resets flying shear software alarms and trips.

19.33 Shear Run Command	
Coding	RW, Bit
Default settings:	0

If this parameter is set to one, on the rising edge, provided all of the interlocks are made the flying shear will start to run, and will continue to run unless a fault condition develops or the run command is removed.

Interlocks:

- Hardware / software limits
- Axis has been homed
- Motion Abort 19.39 = 0
- Axis is ready

When the axis starts it will:

- Go to the start position, defined by parameter 20.39.
- If Cut on start (parameter 19.27) is set then it will perform an initial cut cycle.
- Parameter 19.48 will be set to 1, this may be used as an interlock for the master to start. The flying shear is then ready to run.

19.34 Go to Start Position	
Coding	RW, Bit
Default settings:	0

This parameter is used to send the flying shear axis to the start position that is defined by parameter 20.39. This parameter requires a rising edge to initiate the move. The Shear will move at the Jog speed and acceleration rate.

19.35 Local / Remote Control Select	
Coding	RW, Bit
Default settings:	0

This parameter defines where the command signals are generated, they may be generated from a control word from a fieldbus using parameter `_Sxx%`, `_Rxx%`

NOTE The watchdog must be enabled to allow the Local / Remote mode to be set to remote, this is done to prevent the flying shear from running / jogging or homing unexpectedly.

19.36 Jog Forward Command	
Coding	RW, Bit
Default settings:	0

Set to 1 to jog the flying shear axis forward. Requires a rising edge to initiate the motion, and will continue while the signal is present

19.37 Jog Reverse Command	
Coding	RW, Bit
Default settings:	0

Set to 1 to jog the flying shear axis Reverse. Requires a rising edge to initiate the motion, and will continue while the signal is present

19.38 Home / Datum Command	
Coding	RW, Bit

Set to 1 to home the flying shear axis. Requires a rising edge, the signal does not need to be maintained. This is controlled from default by Analogue input 2 via Drive Menu 12.

19.39 Abort Motion Command	
Coding	RW, Bit

Set to 1 to stop all motion and trip the drive.

19.40 Fwd Hardware Limit Input	
Coding	RW, Bit

This parameter is used as the source for the forward hardware limit. The digital input used for this limit switch input should be set with the destination set to this parameter. This parameter is controlled by Digital Input F5 from default.

19.41 Rev Hardware Limit Input

Coding	RW, Bit
--------	---------

This parameter is used as the source for the Reverse hardware limit. The digital input used for this limit switch input should be set with the destination set to this parameter. This parameter is controlled by Digital Input F6 from default.

19.42 Hardware Limit Polarity

Coding	RW, Bit
--------	---------

Sets the polarity of the Limit switch inputs.

1 = Normally Closed

0 = Normally Open

For safety reasons a fail-safe normally closed switch is recommended.

19.43 Disable Limit Switches during homing

Coding	RW, Bit
--------	---------

Default settings:	0
-------------------	---

This parameter allows the user to disable the limit switches while the axis is homing, this may be needed because the same switch is used for the limit switch and the home switch, or because the limit switch is located inside the home switch. Care must be taken if this feature is used to ensure that it cannot cause injury to persons or damage to the machine if the home or datum switch fails to operate.

19.44 Change forward direction of slave

Coding	RW, Bit
--------	---------

Default settings:	0
-------------------	---

This parameter may be used to change the forward direction of the axis, however the speed will indicate a negative speed when travelling forward. This is only read on power-up or when the scaling is up-dated.

19.46 Tool Raised Input

Coding	RW, Bit
--------	---------

This Parameter should be used to indicate that the tool is raised, and therefore that the flying shear is decelerated. It is ORed with the UD70 TTL.0 input, so that either may be used. If you are using the TTL inputs don't use this parameter, set 19.46 to 0.

19.47 Tool Down Input

Coding	RW, Bit
--------	---------

This Parameter should be used to indicate that the tool is fully down and is ready to rise. It is ORed with the UD70 TTL.1 input, so that either may be used. If you are using the TTL inputs don't use this parameter, set 19.47 to 0.

19.48 Flying shear running	
Coding	RO, Bit
Default settings:	0

This parameter indicates that the Flying shear is running and the cam is enabled, this parameter should be used as a ready interlock, or a start signal to the master / line.

19.49 Tool Enable	
Coding	RW, Bit
Default settings:	0

This parameter is used to enable the tool output to operate, however, it should not be used as a safety feature, and an external fail-safe device that is able to inhibit the tool from operating should be used to protect persons from injury or damage to the machine. If this parameter is not set to 1, the batch control will not function.

19.50 Gap Enable	
Coding	RW, Bit
Default settings:	0

This parameter is used to enable a trapezoidal profile to be added to the cam profile to produce a gap between flying shear cycles, it can only be used in the parallel shear mode.

NOTE Using this mode takes additional processor resources and in some cases especially where fieldbus options are used may cause intermittent nuisance trips.

NOTE This feature is not available in Angled Shear mode (20.41 = 1).

7.1.6 Menu 20

Parameters 20.01 to 20.19 are reserved for Fieldbus set up parameters. Please refer to the following list of manuals for the parameter allocations and set-up.

Manual Description	CT Part Number
Profibus-DP	0460-0075
Interbus	0460-0076
Modbus-Plus	0400-0035
CTNet	0460-0025-03
Devicenet	0460-0077
CAN	0460-0063
CANOpen	0460-0061
UD70 RS485 Port (CTANSI, Modbus RTU, custom)	0460-0098

20.20 Tool Width Compensation	
Coding	RO, Uni
Range:	0 – 32.000
Default:	0
Units:	Units / 1000

This parameter allows for the tool width to be added to the required cut length. This compensation is useful where a saw is used as a cutting tool.

20.21 Minimum Cut Length	
Coding	RO, Uni
Range:	0 – 32000
Units:	Units

This parameter reports the minimum cut length that can be achieved with the current parameters.

20.22 Cam Status Word	
Coding	RO, Uni
Range:	0 - 5

This parameter returns the status of the flying shear profile calculation.

0 = Cam Calculated OK

Faults

Bit 0 = Insufficient travel available for the flying shear to perform flying shear profile

Bit 1 = Cut length is not achievable with flying shear profile parameter.

Bit 2 = Master is too fast, slave is unable to synchronise

20.23 Flying Shear Profile Control Mode	
Coding	RW, Bit
Range:	0 – 1
Default:	0

This parameter is used to specify the operation of the flying shear.

0 = Cyclic cut without registration

1 = Cut on registration mark

20.24 Cut Length	
Coding	RW, Uni
Range:	0 - 32000
Default	500
Units:	Units

This parameter has different functions depending upon parameter 20.23.

If parameter 20.23 is set for cyclic cut, this parameter is used to set the cut length.

If parameter 20.23 is set for Registration, then this parameter is used to set the windowing distance.

20.25 Shear Length / Shear Angle	
Coding	RW, Uni
Range:	1 – 32000
Default:	1000
Units:	Units / 0.01degrees

This parameter depending upon the application / the operating Mode changes definition:

Parallel Shear

The shear length is used to ensure that the flying shear profile does not attempt to exceed the available travel. This parameter should be entered as the amount of travel available from the start position of the flying shear to just before the forward software limit.

Angled Shear

This parameter defines the angle between the flow of the product and the shear carriage in units of 0.01 degrees

20.26 Fly Acceleration / Deceleration Rate / Start Distance	
Coding	RW, Uni
Range:	0 – 32000
Default:	50
Units:	Units / s ² / Units

This parameter defines the acceleration and deceleration rate for the fly part of the profile in Parallel Shear mode.

In Angled Shear mode, this parameter sets the Start Distance. The start distance is equal to 20.29 + an offset to make sure the tool is up to speed before cutting the material. This value can never be smaller than 20.29. See section 6.10.

20.27 Return Acceleration / Deceleration Rate	
Coding	RW, Uni
Range:	1 – 32000
Default:	50
Units:	Units / s ²

This parameter defines the maximum acceleration and deceleration rate when the axis is returning to the start position, following the fly profile.

20.28 Maximum Master Velocity	
Coding	RW, Uni
Range:	1 – 32000
Default:	48
Units:	Units / s

This parameter defines the maximum velocity that the master is expected to travel, it is used for calculating the profile, the master must not exceed this speed.

20.29 Settling time / Accel Distance	
Coding	RW, Uni
Range:	0 to 32000
Default:	50
Units:	ms / Units

The function of this parameter depends upon the operating Mode:

Parallel Shear

The synchronised part of the fly profile is broken down into three areas, settling time, tool down time, and tool up time.

The settling time defines the number of ms that are required to recover following error following the acceleration of the flying shear.

Angled Shear

This parameter defines the distance over which the shear can be accelerated to sync speed.

20.30 Cut Time / Sync Distance	
Coding	RW, U
Range:	0 to 32000
Default:	50
Units:	ms / units

This parameter depending upon the application / the operating Mode changes definition:

Parallel Shear

The cutting time is used to specify the number of ms that the tool cut output needs to be on to perform the cut. E.g. Tool down time.

Angled Shear

This parameter defines the distance (units) over which the shear must be synchronised with the product. This must include enough distance to make sure the tool has come out of the material after the cut. See section 6.10.

20.31 Tool Up time / Decel Distance	
Coding	RW, Uni
Range:	0 to 32000
Default:	50
Units:	ms/units

This parameter depending upon the application / the operating Mode changes definition:

Parallel Shear

The Tool up time is used to specify the number of ms required for the tool up input to be received after the tool cut signal is removed.

At the end of this time the tool up input is interrogated and action is taken according to the setting of parameter 18.33

Angled Shear

This parameter defines the distance over which the shear can be decelerated from sync speed to a stop.

20.32 Cut Length Fine Adjustment	
Coding	RO, Uni
Range:	1 - 32000
Default:	0
Units:	Units / 1000

This parameter is used to provide a fine adjustment to the required cut length.

20.33 FE Cut Limit	
Coding	RW, Uni
Range:	1 - 32000
Default:	0
Units:	Encoder Counts

This parameter is used to specify the acceptable following error during the cut part of the profile.

20.34 Fast Decel Rate	
Coding	RW, U
Range:	1 - 32000
Default:	0
Units:	Units/s/s

This parameter is used to specify the rate at which the flying shear will decelerate if a software or hardware limit is hit.

20.35 Ramp Mode	
Coding	RW, Bit
Range:	0 - 1
Default:	0

If this parameter is set to 1 then s-ramps will be used for the flying shear profile.

NOTE Using this mode takes additional processor resources and in some cases especially where fieldbus options are used may cause intermittent nuisance trips.

20.36 Cam Pointer	
Coding	RO, Uni
Range:	0 – 10

This parameter returns the position of the cam pointer.

20.37 Enable Virtual Master	
Coding	RW, Bit
Default settings:	0

A virtual master may be used for commissioning the application, so that the profiles can be seen without any risk of damage to the machine.

Set to 1 to enable the virtual master.

20.38 Virtual Master Speed	
Coding	RW, Uni
Range:	1 – [max line speed - 20.28]
Default:	50
Units:	Units / s

Set the speed at which you want the virtual master to run.

NOTE The virtual master has no ramps.

20.39 Flying Shear Start Position	
Coding	RW, Bi
Range:	±32000
Default:	0
Units:	Units

This sets Flying Shear start position from Zero position. (18.25). The speed used to travel to the start position is defined by the Jog Speed (18.28).

20.40 Shear Optimisation Mode	
Coding	RW, Bit
Default:	1

This parameter is used to select the mode of optimisation for the return part of the shear profile when in cyclic mode.

0 = Slow

1 = Fast

In slow mode the shear will return to the start position at the minimum speed, but with enough pace to immediately start the next cut without the need to stop.

In fast mode the shear will return at the maximum accel, decel and speed, and will then dwell at the start position before beginning the next cycle. Refer to parameter 19.31 manual cut for scrap cuts setup. If Registration is used, fast return is preferred.

20.41 Angled Shear Enable	
Coding	RW, Bit
Range:	0 – 1

The software is able to handle both parallel flying shears and Angled flying shears, where the shear is positioned at an angle to the production flow.

20.42 Registration Fine Offset	
Coding	RW, Uni
Range:	±32000
Default:	0
Units:	Units / 1000

The distance between a Registration sensor and the start position of the knife is set by parameter 20.43, This parameter gives a fine offset to allow higher accuracy.

NOTE This should be set to a positive value, provided that registration sensor is before the knife in the direction of the material flow.

20.43 Registration offset	
Coding	RW, Uni
Range:	±32000
Default:	0
Units:	Units

Distance between the registration sensor and the flying shear start position.

20.44 Registration Window Enable	
Coding	RW, Bit
Default:	0

Set to 1 to enable registration windowing.

20.45 Registration Window Tolerance	
Coding	RW, Uni
Range:	0 – 32000
Units:	Units
Default:	0

This parameter is used to set the open and close position for the window and any marks detected outside the tolerance will be rejected.

Parameter 20.24 is used to set the distance for the centre position of the window.

20.46 Preset Master Position command	
Coding	RW, Bit
Default:	0

On the rising edge this parameter is used to preset the position of the master axis to the value in parameter 20.47, so that the windowing function can be used.

20.47 Master Position Preset Value	
Coding	RW, Bi
Range:	±32000
Units:	Units
Default:	0

This value is used to preset the master position on the rising edge of parameter 20.46

20.49 Application Software Version	
Coding	RO, U

7.1.7 PLC Registers

The following Application PLC registers are reserved for internal use and should not be used or written to via serial communications:

71.51 to 71.71 and 71.96 to 71.99

The following Application PLC registers are used for serial communications control and status word:

72.69 – Fault word
 72.70 – Status Word 1
 72.71 – Status word 2
 73.70 – Control word

Refer to section Serial Communications / Fieldbus Control for more details.

8 Error Handling / Trouble Shooting

8.1 Application Error Handling

As the system is designed to be as flexible as possible, some trips may or not be required depending upon the individual application, and so we have given the system engineer the flexibility to do a risk analysis and decide how the errors are handled.

Options available:

- No alarm, no trip
- Alarm & no trip
- Alarm & trip Drive Immediately
- Alarm & trip drive if idle or otherwise after current flying shear cycle

These are set using three registers that contain an individual bit for each of the error states:

Bit	Description
0	Tool did not rise at the end of the cycle – Alarm only
1	Following Error Outside Limit
2	Other tool error
3	Start Cut Error, master not stationary
4	Cam calculation parameter fault
5	Master Speed too fast
6	Sequence abort parameter fault
7	Homing Fault
8	Fwd H/W Lim
9	Rev H/W Lim
10	Fwd S/W Lim
11	Rev S/W Lim
12	Remote Fieldbus Trip
13	Watchdog fault error

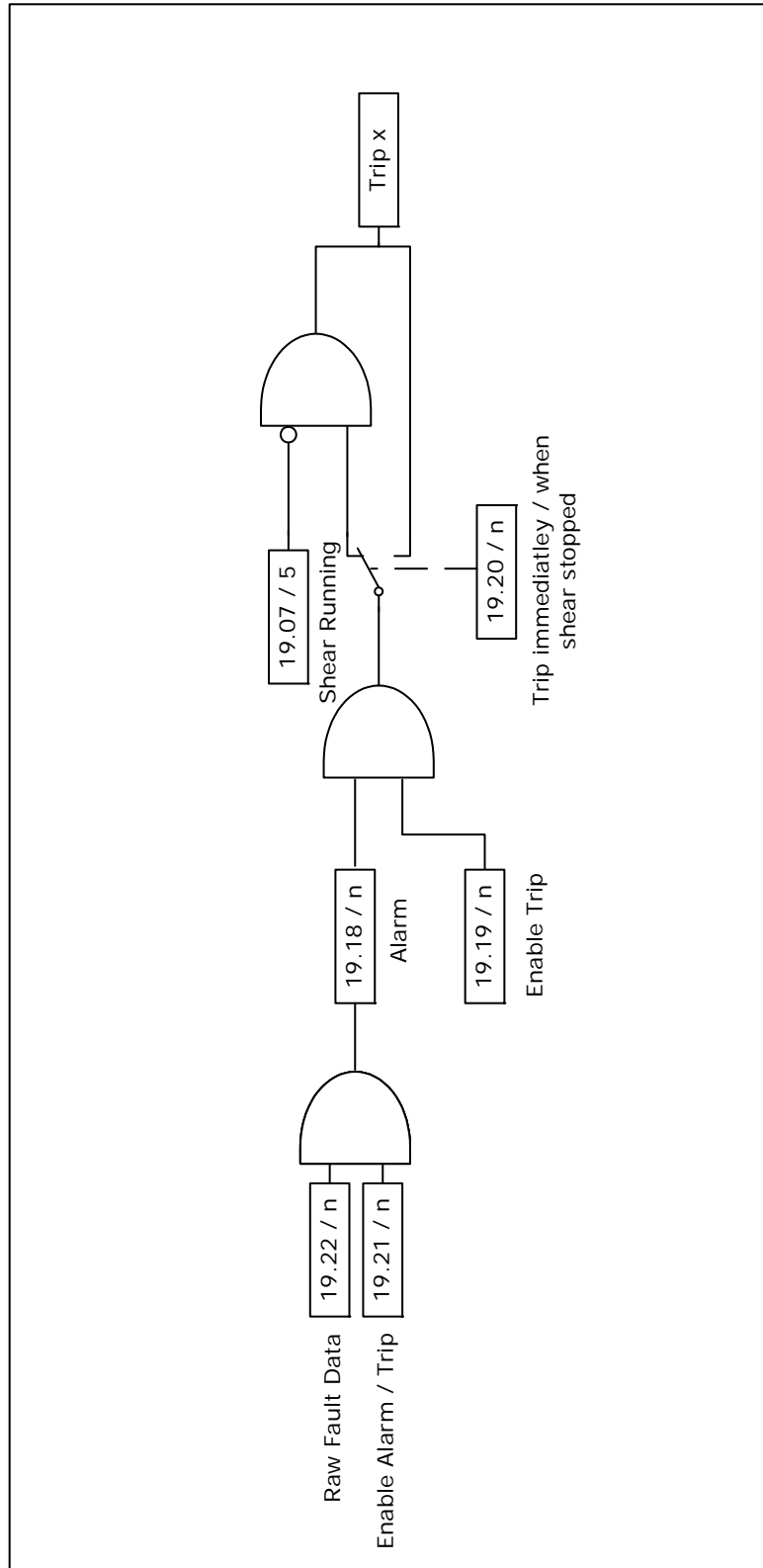

8.1.1 Trip Codes

Trips 40 to 60 - UD70 / Comms option module trips

(Refer to UD70 User Guide)

Trips 80 to 94 – Application specific trips

Trips 95 to 99 – Application standard trips

Trip Number	Description
Tr80	Tool Did not rise at the end of the cycle
Tr81	FE Limit Error
Tr82	Other tool error
Tr83	Start Cut Error, master not stationary
Tr84	Profile Calculated Incorrectly
Tr85	Master Over speed Error
Tr86	Sequence Abort Parameter 19.39
Tr87	Homing Error, Refer to 18.01 for Details
Tr88	Forward Hardware Limit Error
Tr89	Reverse Hardware Limit Error
Tr90	Forward Software Limit Error
Tr91	Reverse Software Limit Error
Tr98	Remote Fieldbus Trip
Tr99	Communications Watchdog Error

Trip 80

This alarm / trip is set when the tool is not up at the end of the flying shear cycle, it is only used only if Tool Sync parameter 18.33 is set to 1, the trip will only occur when the axis is stationary, and so trip immediately is disabled.

Trip 81

This trip can be caused by either a general following error trip, which is set when the following error exceeds the value set by parameter 19.11 or when the following error is exceeds parameter 20.33 during a cut cycle, in the later case the following error is only checked before the tool is fired.

Trip 82

This trip can occur for a number of reasons, refer to parameter 19.26 for modes:

Tool not up at the start of the cut cycle

Tool not up at the end of the sync period

The tool down signal is not set at the end of the cut period

The following error is exceeded, and cut is aborted

Trip 83

This trip will occur only if cut on start parameter 19.27 is set, and occurs when the master axis is not stationary to allow the cut to take place.

Trip 84

The flying shear profile cannot be achieved. This should not cause a dangerous condition, as the old profile will continue to be used until a suitable cam is calculated. The cause for the calculation error is given by parameter 20.23.

Trip 85

Master speed exceeds the value set by parameter 20.28 by more than 10%.

Trip 86

Sequence abort parameter 19.39 is set to 1.

Trip 87

A homing fault has occurred, such as the home sequence has taken too long and has timed out. Refer to parameter 18.01 for more detail.

Trip 88 – 91

Hardware and Software Limits

Trip 98

Set by the remote control word, parameter `_S70%` bit 7.

Trip 99

This trip occurs if the watchdog is enabled (parameter 18.45 is set), and is caused by a communication loss between a remote device and the UD70.

8.1.2 Drive Trip Recovery

When the drive trips the application programme will be reset when the drive is reset. However, the cause of the trip may still be present, such as a hardware limit may be active, the application software will prevent the drive from tripping again so that the cause of the problem can be fixed, but will prevent the system from restarting until the trip condition is reset. If for example the forward hardware limit is hit and this trips the drive, after a reset, the only operation that the drive will be able to perform will be jog reverse, to move the axis off the limit switch. Following a drive trip 19.32 must be toggled to reset the system, and a homing sequence must be performed.

9 Advanced Features

9.1 Serial Communications / Fieldbus Control

9.1.1 Control Word `_S70%` (Parameter 73.70)

Introduction

The fieldbus control word is an efficient way of remotely controlling the motion of a Drive. Due to the restriction of most fieldbus word length the control word length will be no more than 16bits, UD70/MD29 PLC register `_S70%` will be used to ensure full resolution is maintained (e.g. drive parameter limited to 32000 or 1000).

Each bit in the fieldbus control word has a particular function, and provides a method of controlling the output functions of the Drive (RUN, JOG, TRIP, etc.) with a single data word, (16Bits).

To use the fieldbus control word, the ENABLE terminal on the drive must be closed, and the MASK bit must be set to 1. The 0-1 transition of the MASK bit will cause the digital I/O control to be switched from local terminal mode to fieldbus control.

When the MASK bit is reset to 0, the Digital I/O control is switched terminal control mode.

A selector switch can also be used to select between local (terminal) and remote (fieldbus) control of the Drive. If a digital input is configured to directly control mode parameter assigned (MM.PP), the value written by the Main Title interface will be immediately overwritten by the digital input.

NOTE

If you use the SYPT watch window or similar monitoring tool for the purpose of commissioning, you must have the Watchdog enabled (18.45 = 1), and the Watchdog trip disabled (19.21 bit 13 = 1).

_S70% or Pr73.70

Bit	Function	Description
0	ENABLE	Must be set to 1 to put the Unidrive in READY mode. Resetting to 0 will immediately disable the Drive, and the motor will coast to stop.
1	Run	Set to 1 to run the flying shear cycle, when reset to zero the flying shear will stop at the end of the current cycle.
2	Jog FWD	Set to 1 to run the motor in the forward direction. When reset to 0, the motor will stop
3	Jog REV	Set to 1 to run the motor in the Reverse direction. When reset to 0, the motor will stop
4	MASK	A 0-1 transition of this bit will set MM.PP to 1 to enable fieldbus control of the Drive. 19.35 can subsequently be over-written by a digital input if a terminal or fieldbus control selector switch is required. (A 1-0 transition will reset 19.35 to 0.)
5	Reserved	
6	RESET	A 0-1 transition will reset the drive from any trip condition. If the cause of the trip has not been cleared, the Drive will not trip again immediately.
7	TRIP	A 0-1 transition will force a "tr98" trip on the Drive. If the RESET and TRIP bits change from 0 to 1 on the same cycle, the TRIP bit will take priority.
8	Home	A 0-1 transition will initiate a homing sequence
9	Tool Enable	If set to 1 then the cutting tool is enabled
10	Start Pos	A 0-1 transition will command the drive to travel to the start position.
11	Save Pars	A 1-0 transition will perform a Save of parameters
12	Acquire	A 0-1 transition will allow the motion profile parameters in menu 20 to be acquired and to re-calculate the CAM profile using the new profile data together, when 18.39 = 1.
13	Manual cut	A 0-1 transition will cause a manual cut. See parameter 19.31 for more details.
15	WDIn	Watchdog In - Comms clock from remote device.

The recommended control method for the PLC program is to reset the fieldbus control word to a safe state, e.g. Drive disabled. When a fault is detected with either the Application software or communication link, the Drive control word is reset to 0 automatically when the Drive trip is reset. When the Serial Communication link is healthy again, the appropriate fieldbus control word can be set, the Drive control word will in turn be updated and the Drive will restart. Some example fieldbus control word values to control the Drive are given in the table below.

WDin is the communication watchdog bit transmitted from remote intelligent device, (PLC, keypad or CTIU, etc).

9.1.2 Fault Word _R69% (Parameter 72.69)

The Fault word returns the current fault status of the drive.

Bit	Description
0	Tool Raised Switch Error
1	Following Error Outside Limit
2	Tool did not rise at end of the cut sequence
3	Remote Fieldbus Trip
4	Cam calculation parameter fault
5	Watchdog fault error
6	Sequence abort parameter fault
7	Homing Fault
8	Fwd H/W Lim
9	Rev H/W Lim
10	Fwd S/W Lim
11	Rev S/W Lim
12	Master Speed too fast
13	Watchdog Error

9.1.3 Status Words _R70%, _R71%

Status Word 1 _R70% (Parameter 72.70)

Bit	Parameter	Description
0	10.01	Drive healthy
1	10.02	Drive Output Stage Active
2	10.03	Zero speed
3	8.07 & 06.15	Drive Enabled (Ready)
4	01.11	Reference ON
5	-	Master Speed Is At Zero
6		
7		
8		
9		
10		
11		
12		
13		
14		
15		

Status Word 2 _R71% (Parameter 72.71)

Bit	Description
0	Jogging
1	Travelling To Start Position
2	At Start Position
3	Homing Sequence In Progress
4	Homing Completed
5	Flying Shear Cycle Running
6	Cyclic Mode Selected
7	0 = Local 1= Remote
8	Registration Mode Selected
9	New Cam is being Calculated
10	Cam is Ready
11	On Last Cut In Batch
12	Batch Done
13	Shear Is Ready To Run
14	Alarm Active
15	Watchdog Out

NOTE The watchdog must be enabled to allow the Local / Remote mode to be set to remote, this is done to prevent the flying shear from running / Jogging and Homing unexpectedly. Parameter 19.07 contains the same information as _R71%.

CTIU – Operator Panel

The CTIU operator interface enables the user to monitor, set-up and control the flying shear application remotely without the need to use the manual or Unidrive parameter numbers. All parameters are displayed in text rather than using it's Unidrive parameter number. Textual descriptions are also given for trips/alarms, Boolean statuses/settings and selection parameters. On line Help descriptions are available for further information on the configuration parameters.

Front View of CTIU110

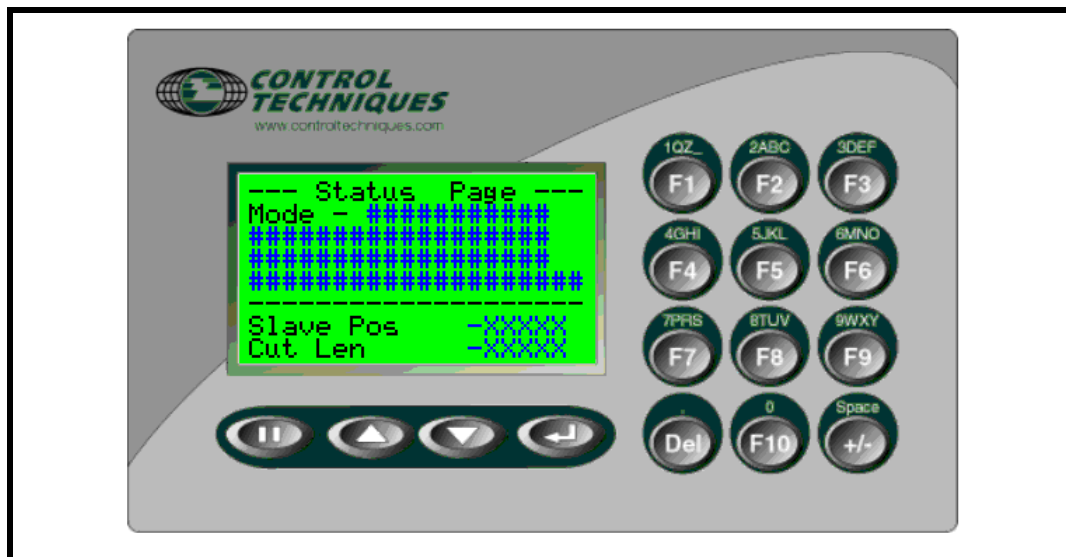

9.2 Software Version

CTIU Software Version – V01.00.00 or greater, this will be displayed on the CTIU second splash screen or can be found under the ‘Drive Diagnostics’ menu

9.3 Mechanical Installation

Panel Cut-out Detail

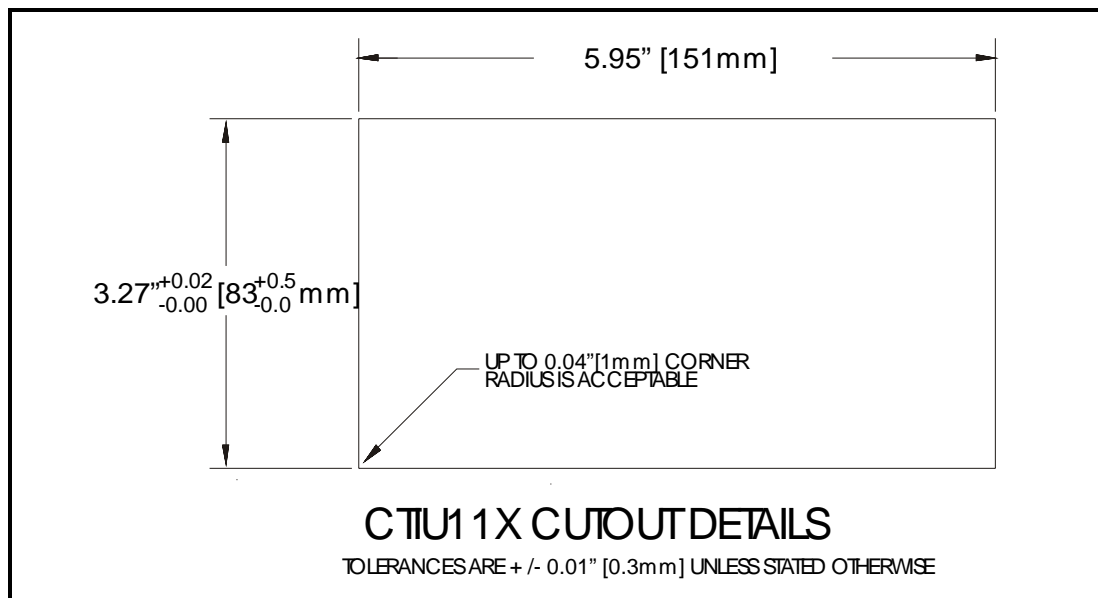

9.4 Electrical Installation

9.4.1 CTIU110 Rear View

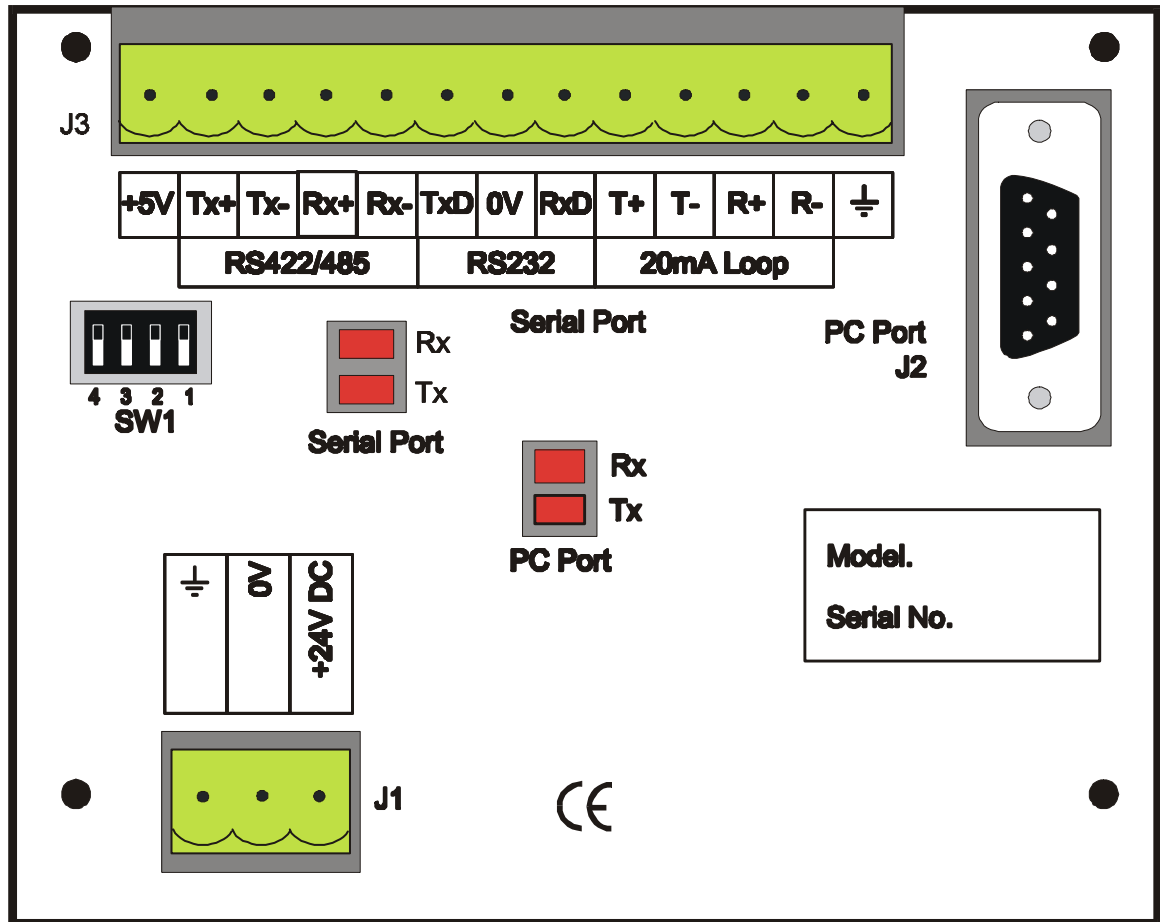

24Vdc Power Supply Requirements (J1)

Peak Inrush – 240mA

Continuous – 100mA

9.4.2 Serial Communications Cable Connections

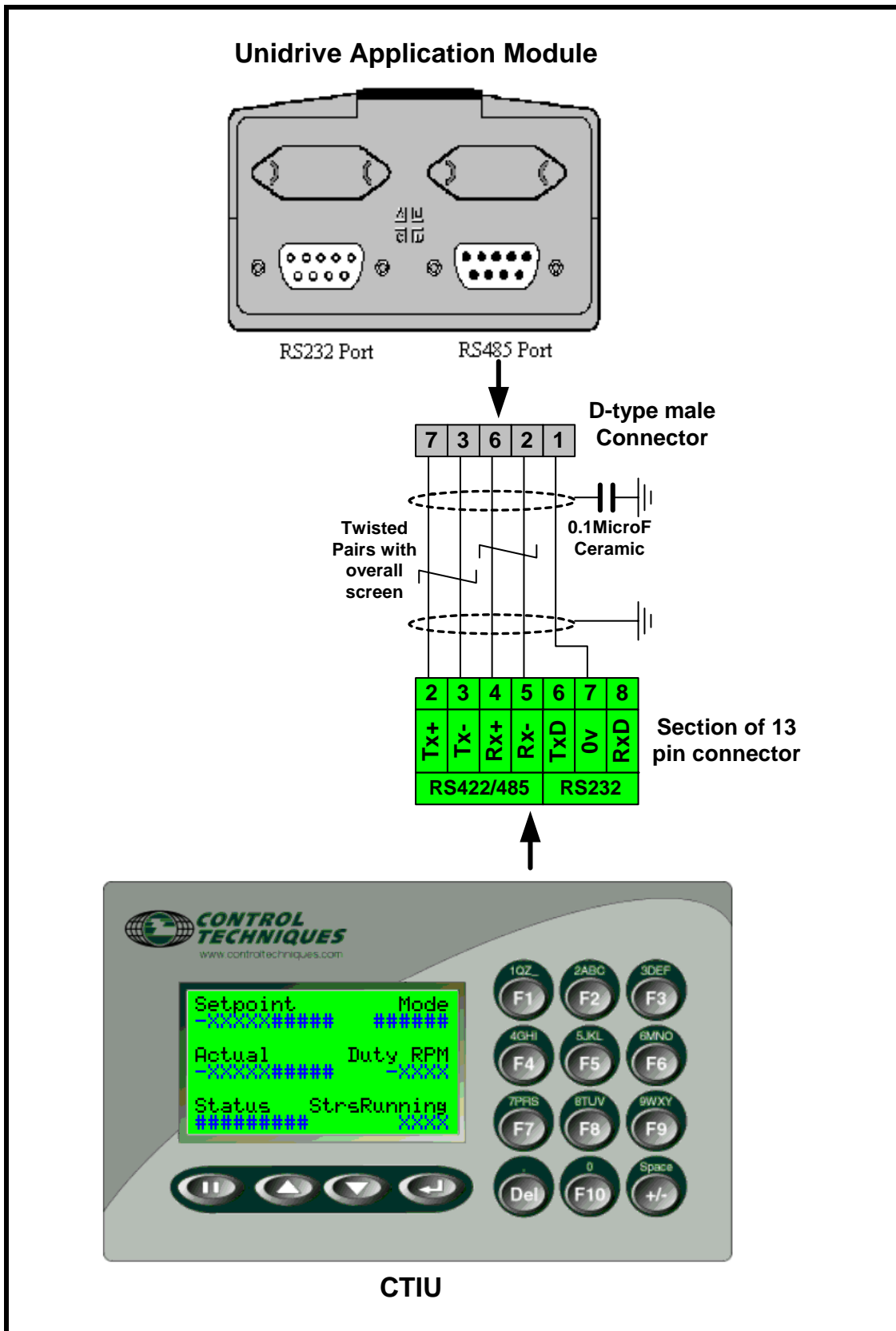

Recommended Cables

Belden No. 8105, 9807 or 9832 – General Purpose
 Belden No. 8165 – Heavy Noise Environment

9.5 Unidrive set-up

The protocol used between the CTIU110 and the Unidrive application module is Modbus RTU. To establish communications the Unidrive Address, Baud rate and Protocol is required to be set, the following table details the required parameters to be set:

Parameter	Setting	Description
17.05	11	Drive address
17.06	13	RS458 Modbus-RTU protocol mode
17.07	19200	Baud rate

NOTE Perform a Drive save to save these setting during power down.
e.g. XX.00 = 1000 followed by reset.

9.5.1 CTIU110 Configuration of the RS-485 Port

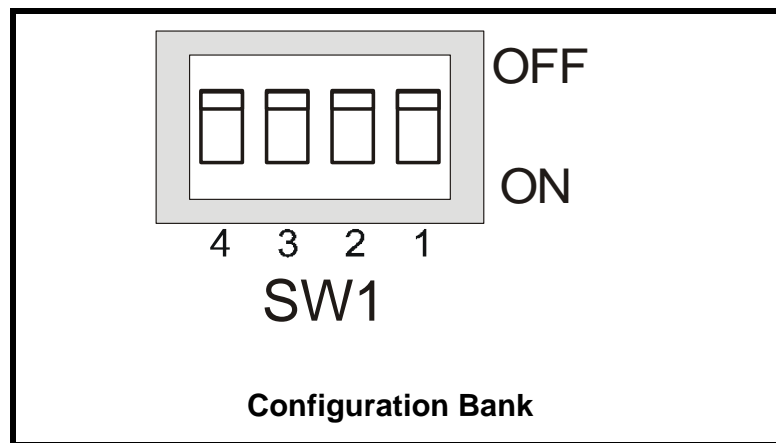

The configuration bank sets the parameters of the RS-485 port as described in Table 4.1.

Configuration Bank Description	
Switch 1	ON: Pull-up (must be used together with switch 3) OFF: no Pull-up
Switch 2	ON: 120Ω termination OFF: no termination
Switch 3	ON: Pull-down (must be used together with switch 1) OFF: no Pull-down
Switch 4	Reserved for future use
NOTE	
Switch 1 and 3 must be used together. Either both pull-up and pull-down are used or neither is used.	

Pull-up and **Pull-down** switches are used to increase the signal level on the RS-485 bus. This is useful if there is a long bus and a significant amount of attenuation is anticipated.

Termination resistance of 120Ω must be placed across each end of the RS-485 bus. With switch 2 ON, a 120Ω resistance is placed across the bus. This should only be used if the CTIU050/100/110 is the last device at either end of the bus.

9.6 Operation Button Selection Actions

PAUSE key selects data for editing OR exits from data editing.

PAUSE & DOWN keys pressed together, enters sub menu pages.

PAUSE & UP keys pressed together, exits sub menus to the parent menu pages.

UP key selects the previous menu page, sub menu page, alarms, and increments data

DOWN key selects the next menu page, sub menu page, alarms and also decrements data.

ENTER key sends data to the automation equipment, accepts alarms, and displays accepted alarms.

ALPHANUMERIC KEYPAD and **PROGRAMMABLE KEYS** can be used to enter data or can be used to preform some pre-programmed action.

Contrast Adjustment

On menu page 1 (after the start-up screen), hold the ENTER key and press the UP or DOWN key to adjust the contrast. The contrast setting is stored and not lost after removing power.

9.7 Navigation

The flying shear screens are split into 2 sections:

- Operator section
- Configuration section

The flying shear parameters are grouped into relevant application menus to aid with efficient navigation to each parameter. Each menu has two parts,

A parent menu page, this is the menu header and displays the menu description.

Sub-menu page/s containing all the relevant parameters for the menu.

e.g. Parent Menu Page: I/O Diagnostics

Sub-menu Pages contain relevant parameter for the Parent Menu: -

All status of the Digital Inputs and Outputs Terminals: 1&2 and 24-30.

The current values on all Analogue input terminal: 05-08.

Using on-screen graphical icons the following sections describes how to navigate between Parent and sub-menu screens.

9.7.1 Parent Menu Pages Navigation

Parent Menu Page UP
This signifies the parent menu navigation direction. When this symbol is shown, pressing the 'Up' key will display the next parent menu page up from the current.

Parent Menu Page Down
This signifies the parent menu navigation direction. When this symbol is shown, pressing the 'Down' key will display the next parent menu page down from the current.

The image shows a Control Techniques keypad with a green LCD screen. The screen displays 'APP DIAGNOSTICS' in the center, flanked by left and right navigation arrows. Above the screen is the Control Techniques logo and website address. To the right of the screen is a numeric keypad with function keys F1-F10. Below the screen are four navigation keys: a pause key, an up arrow key, a down arrow key, and a left arrow key. Red arrows point from the text blocks to the left and right arrows on the screen, and from the 'Parent Menu Page Down' text to the down arrow key.

Sub-menu Access
This indicates the two keys that need to be pressed to access the Parent sub-menu.
e.g. to access the Process Diagnostic sub-menu pages, press the Pause and Down keys together.

9.7.2 Sub Menu Pages Navigation

Help

Many of the configuration sub-menu pages are provided with a brief help description for each parameter. Pressing the F10 key will display the help information for the parameters displayed on the current sub-menu page .

Parent Menu Access

Press the Pause and the Up keys together to go back to the Parent menu page. This will be indicated on the last page on each sub-menu

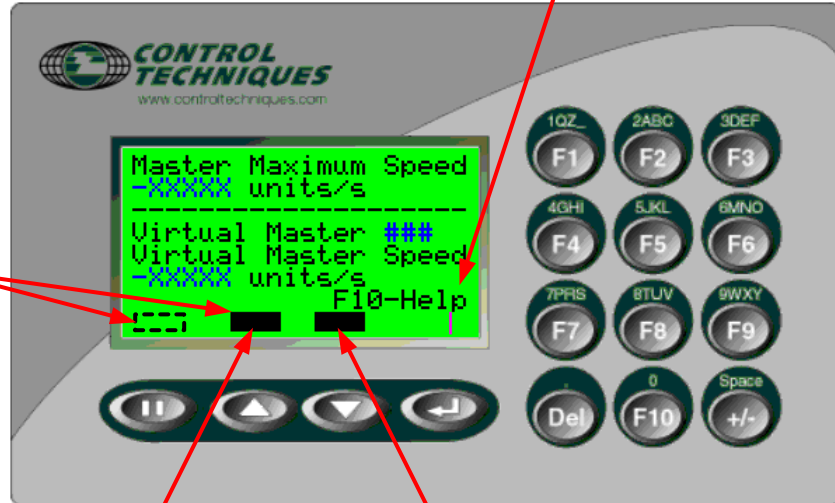

Sub-menu Page UP

This signifies the sub-menu navigation direction. When this symbol is shown, pressing the 'Up' key will display the next sub-menu page up from the current.

Sub-menu Page Down

This signifies the sub-menu navigation direction. When this symbol is shown, pressing the 'Down' key will display the next sub-menu page down from the current.

9.8 Operators Screens Description

The operator screens consist of:

- Top-level main page which provides an overview of all the important parameters of the shear on one screen
- Diagnostic information for drive and the application
- Process set points.

These screens are detailed in the Operators navigation diagram shown below.

9.8.1 Top Level Screen and Functionality

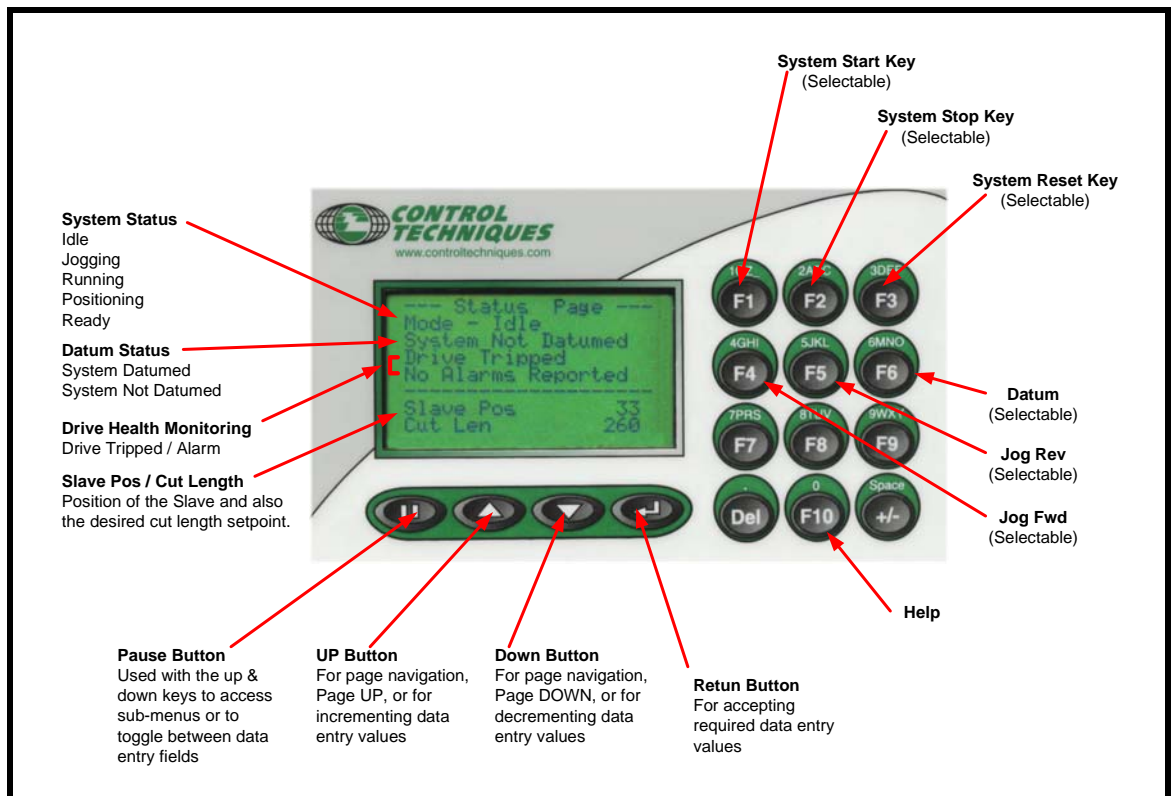

The top-level screen indicates all the common variables for process/application, e.g. set points, feedbacks, status etc. The Top-level screen is always the first menu Page to be displayed. A Menu Timeout, safety feature is used to force the CTIU display focus back to the first (main) menu page after a set time period. The Menu Timeout period is set to 300 seconds (5mins).

9.8.2 Diagnostic Screens

The following diagnostic screens are available:

Application Diagnostics

Displays parameters directly related to the process control, Feedback alarm thresholds; Feedback; Current alarm status.

Drive Diagnostics

Displays parameters directly related to the Flying Shear drive, Frequency, Volts, Power, Speed, DC Bus Volts, Current, Overload accumulator; Fault log; Software versions.

I/O Diagnostics

Displays parameters directly related to the Flying Shear drive inputs & outputs, Unidrive standard and option digital status's and analogue current values.

Operator Navigation

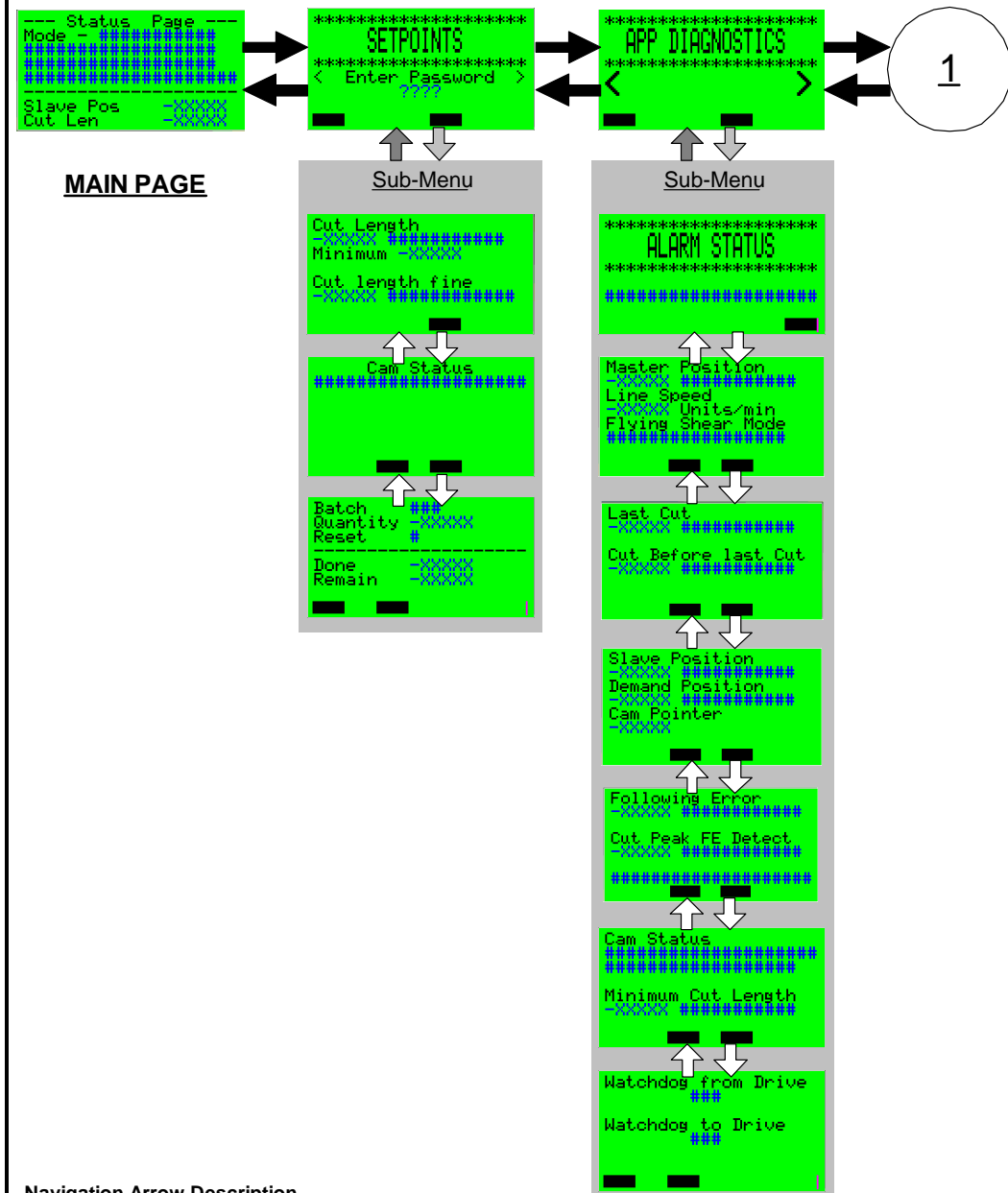

Navigation Arrow Description

- Denotes navigation direction of the parent Menu pages.
 This is achieved by using the up & down arrow keys on the CTIU.
- Denotes navigation direction between the parent menu page & sub-menu pages. (without password).
 To access the sub-menu from the parent menu page press the pause and the down arrow keys together.
 To go back to the parent menu page from the submenu press the pause and the up arrow keys together.
- Denotes navigation direction between the parent menu page & sub-menu pages. (with password).
 This has the same functionality as the Blue arrow but a password is required before access is given to the sub menu.
- Denotes navigation direction of the sub-menu pages.
 This has the same functionality as the Black arrow.

Operator Navigation

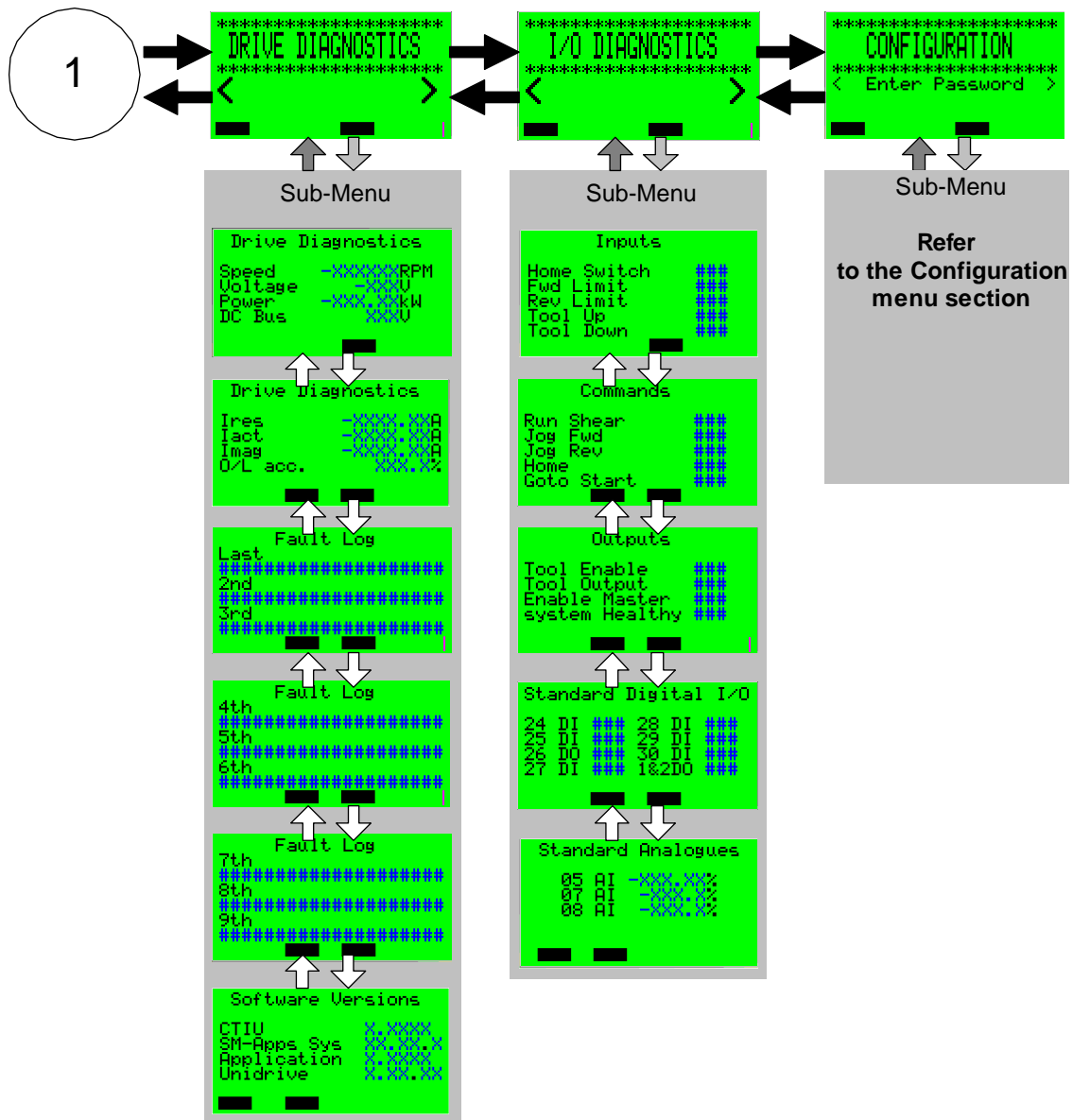

Navigation Arrow Description

- Denotes navigation direction of the parent Menu pages.
This is achieved by using the up & down arrow keys on the CTIU.
- Denotes navigation direction between the parent menu page & sub-menu pages. (without password).
To access the sub-menu from the parent menu page press the pause and the down arrow keys together.
To go back to the parent menu page from the submenu press the pause and the up arrow keys together.
- Denotes navigation direction between the parent menu page & sub-menu pages. (with password).
This has the same functionality as the Blue arrow but a password is required before access is given to the sub menu.
- Denotes navigation direction of the sub-menu pages.
This has the same functionality as the Black arrow.

Configuration Navigation

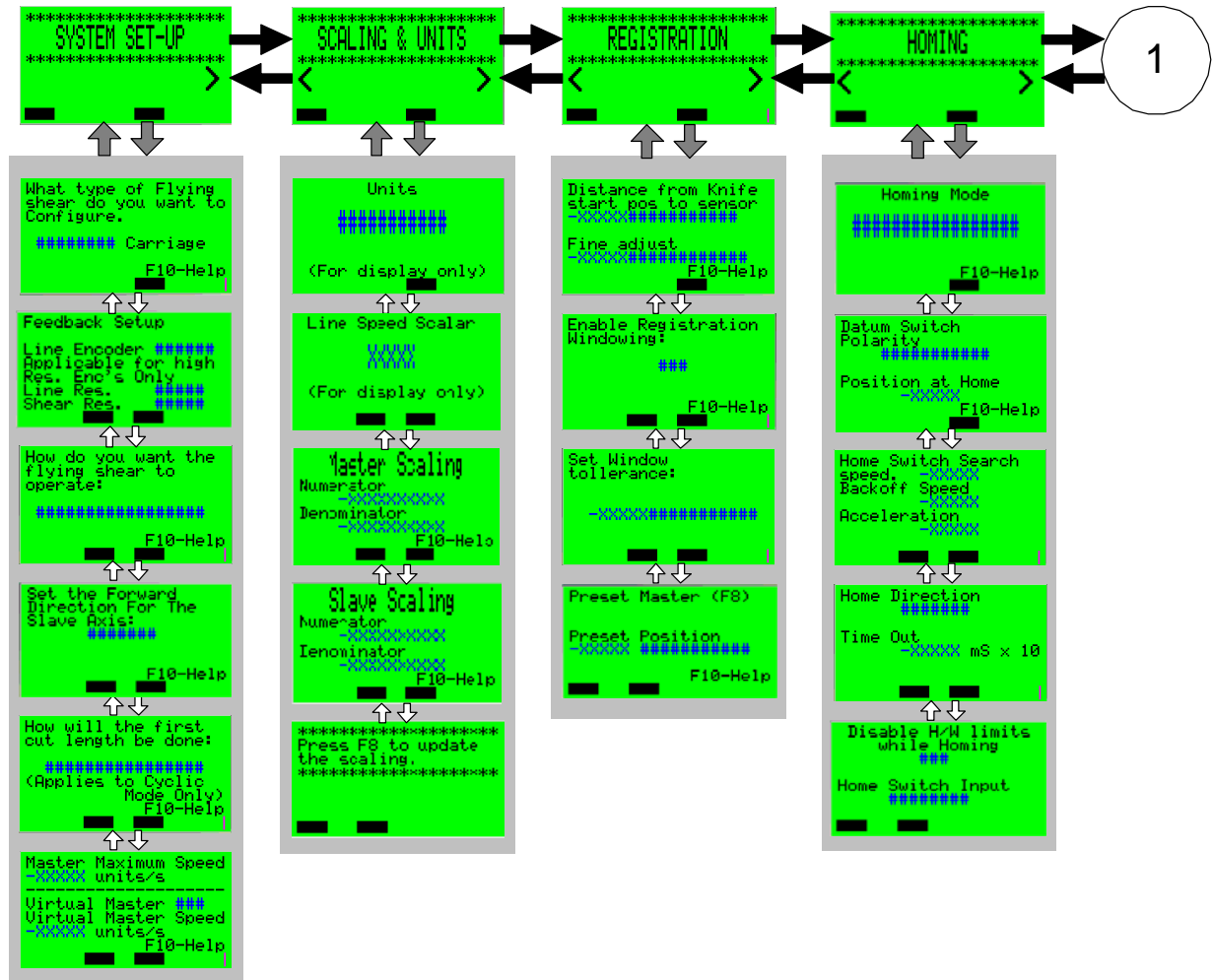

Navigation Arrow Description

- Denotes navigation direction of the parent Menu pages.
This is achieved by using the up & down arrow keys on the CTIU.

- Denotes navigation direction between the parent menu page & sub-menu pages. (without password).
To access the sub-menu from the parent menu page press the pause and the down arrow keys together.
To go back to the parent menu page from the submenu press the pause and the up arrow keys together.

- Denotes navigation direction between the parent menu page & sub-menu pages. (with password).
This has the same functionality as the Blue arrow but a password is required before access is given to the sub menu.

- Denotes navigation direction of the sub-menu pages.
This has the same functionality as the Black arrow.

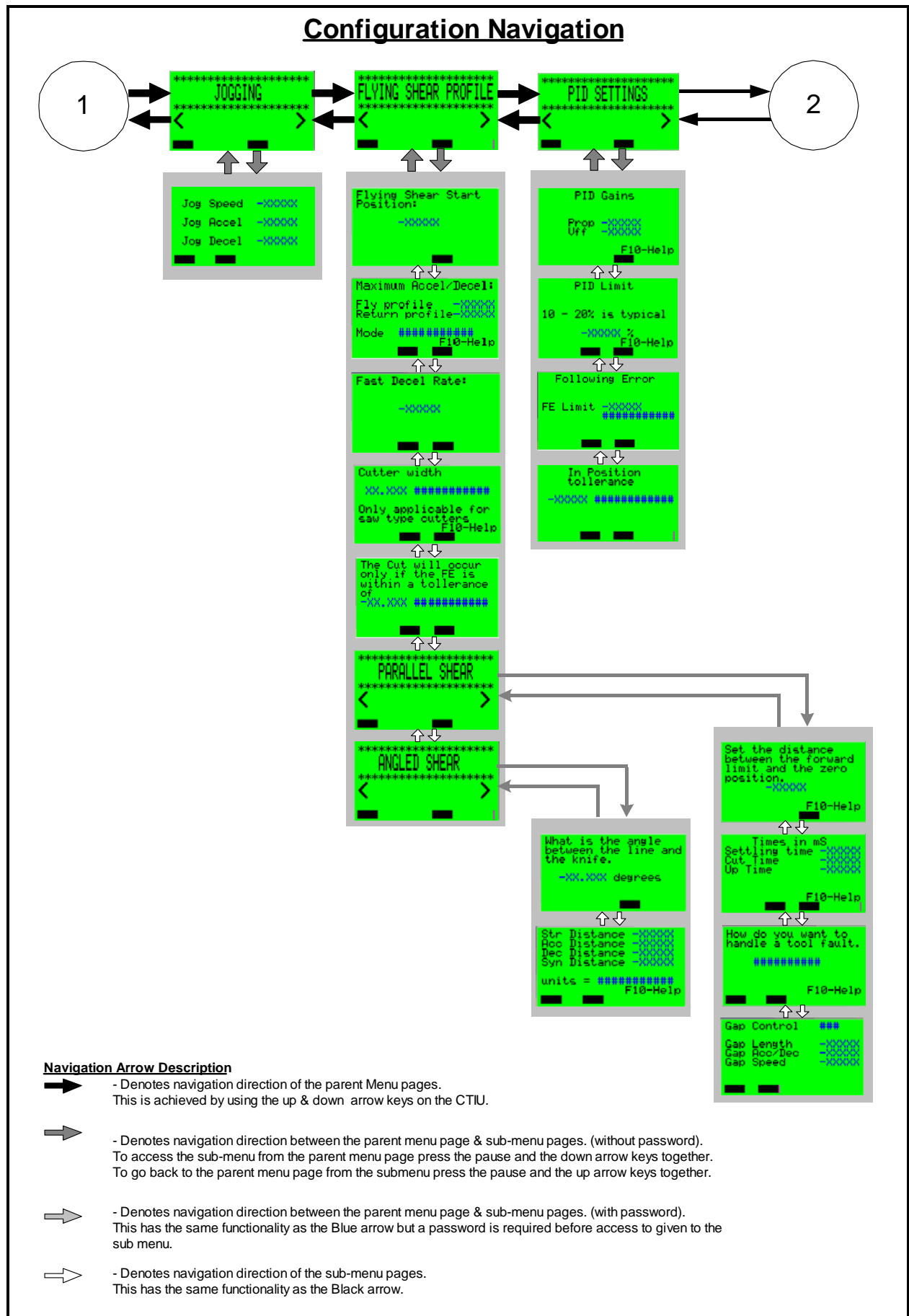

Configuration Navigation

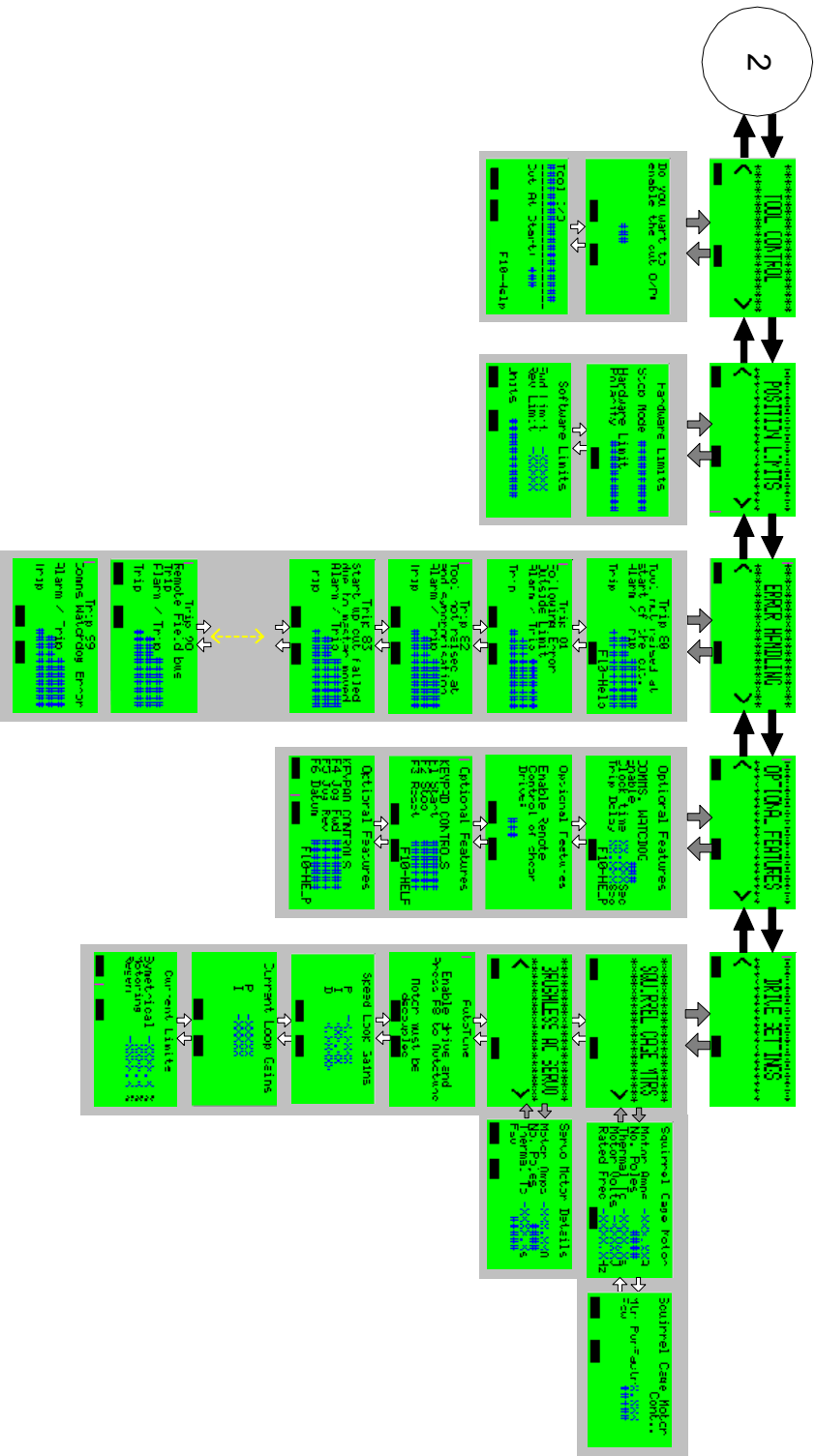

Navigation Arrow Description

- ➔ Denotes navigation direction of the parent Menu pages. This is achieved by using the up & down arrow keys on the CTU.
- ➔ Denotes navigation direction between the parent menu page & sub-menu pages. (Without password). To access the sub-menu from the parent menu page press the pause and the down arrow keys together. To go back to the parent menu page from the submenu press the pause and the up arrow keys together.
- ➔ Denotes navigation direction of the parent menu page & sub-menu pages. (With password). This has the same functionality as the Blue arrow but a password is required before access to given to the sub menu.
- ➔ Denotes navigation direction of the sub-menu pages. This has the same functionality as the Black arrow.

9.9 Access

To gain access to the Setpoints and Configuration menu's a password must be entered. To enter the password press the pause key, this will then highlight the password digits (0000). After entering the password which is 9999, press the pause key a second time. You will now be able to access the menu by pressing pause and down at the same time. If it is desirable to give the shear operator Setpoint access only, the number 5555 should be entered using the method above.

9.10 Splash Screens

There are two splash screens displayed in sequence during initial power up. These detail the application and software version information.

9.10.1 Application Page (1st Page)



9.10.2 Software Version Page (2nd Page)

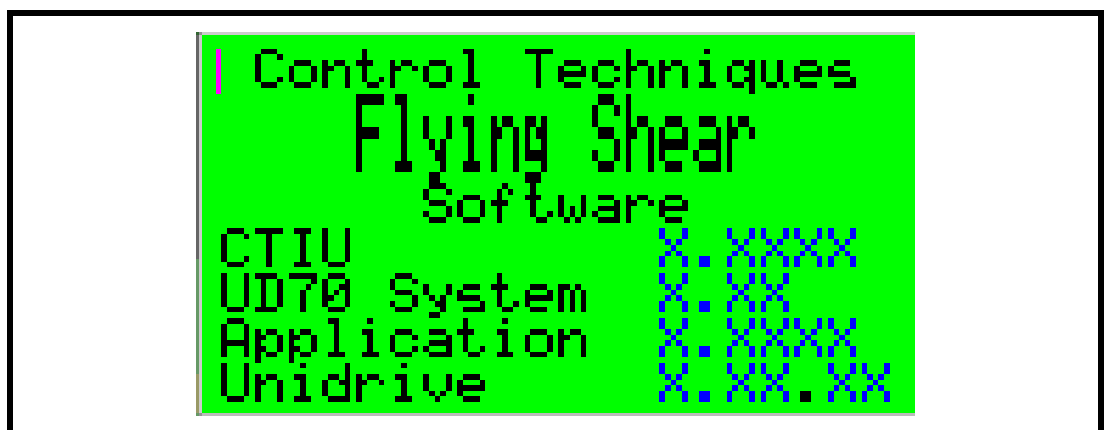

9.11 Parameter Save

When any of the editable data fields has been changed within the configuration menus and the Top-level menu page (1) is display (due to timeout, or forced by the user), a parameter save will be prompted to the operator.

9.11.1 Parameter Save Main Screen

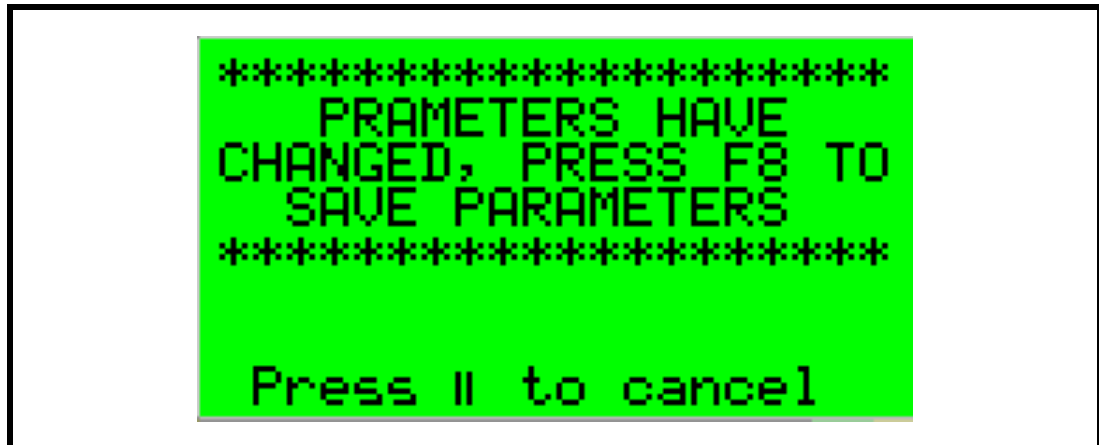

This is the first screen to be displayed, where it indicates to the user to save parameters by pressing Function key F8. To save the parameters the Unidrive must be in stopped state, a flashing message will advise if a save can be performed.

e.g. Flashing Message

Drive Running – Stop Drive to Save

Drive Stopped – OK to Save

If a parameter save is not required the pause (||) key can be press to quit back to the Top-level menu page (1).

9.11.2 Parameter Save Acknowledgement Screen

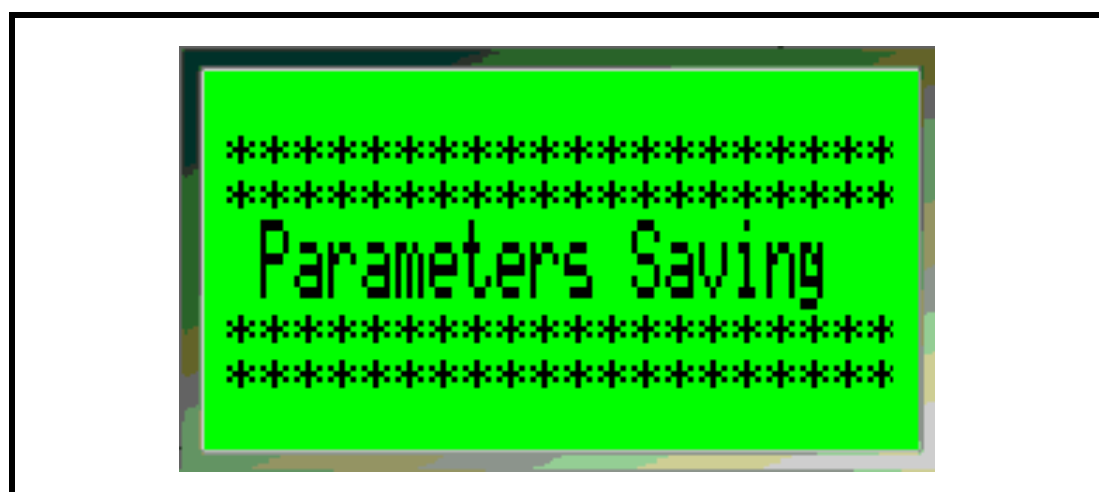

When function key F8 is press with the Drive stopped the above screen will appear acknowledging a parameter save is being performed. After approximately 5 seconds the top level menu page (1) will re-appear, confirming the save has completed.

9.12 Trip & Alarm indication

There are two types Alarm pages:

- Trip – Indication the system has tripped and needs a reset to resume operation. (Unless the result of the trip has caused permanent damage)
- Alarm – Indication of alarms that will not stop the system but may restrict the operation, or advise the process is close to or on process limits.

Starter alarms will lock out the corresponding starter and make it unavailable for selection, these alarm require a reset to make the starter available again. Indication is given where a reset is required with an alarm.

All pages have to be acknowledged by the pressing of the 'Return' key. This will remove the Alarm page from the display only; this will not reset any trips or alarms on the drive. A trip or alarm reset is a separate function and can be performed from the CTIU (F3 key when feature is enabled), or from another source (Pushbutton, PLC, etc). When a trip or an alarm is acknowledged but not reset, the Alarm page will be removed from the display of the CTIU. To make the operator aware this is still a trip or an alarm still present, the top level menu page (1), 'Status' data field will indicate that the system has a 'Fault' or an 'Alarm' present. Pressing the 'Return' key while on the top-level menu page (1) will toggle between the Alarm page and the top-level menu page. The alarms and trips can also be review in the following 'Diagnostic Menus':

- Alarms – Process Diagnostics (page 1 of sub menu)
- Trips – Drive Diagnostics (Page 3 Last Fault logged)

9.12.1 TRIP Page (Alarm page 1)

Trip Description
Text table with reference to Unidrive parameter #10.20

Acknowledge
Press Return Key. This will not reset fault.

9.12.2 ALARM Page (Alarm page 2)

Alarm Description
Text table with reference to Internal variable %R0035

Acknowledge
Press Return Key. This will not reset alarms where required.

9.13 CTIU Function Keys Allocation

9.13.1 Global Control Function Keys

The following Function keys can be optionally configured from the Configuration 'Optional Features' menu. These function keys allow the flying shear application to be fully controlled from the CTIU without the need for addition switchgear (switches, pushbuttons etc). These function keys, when selected, are active on every display focus, and will control the application provided the 'Remote select' parameter is set (19.35 =1):

F1 – Start, sets bit 1 of the control word when the function key is enabled and pressed.

F2 – Stop, reset bits 1 of the control word when the function key is enabled and pressed.

F3 – Reset, toggles bit 6 of the control word when function key is enabled and pressed and resets to zero when released (pushbutton type).

F4 – Jog Forward, toggles bit 2 of the control word when the function key is enabled and pressed. and resets to zero when released (pushbutton type).

F5 – Jog Reverse, toggles bit 3 of the control word when the function key is enabled and pressed. and resets to zero when released (pushbutton type).

F6 – Datum, toggles bit 8 of the control word when the function key is enabled and pressed. and resets to zero when released (pushbutton type).

N.B: When the keys are configured it is important to remember to press the Enter key after changing a Function key setting, failure to do this will result in the key reverting back to its previous setting.

NOTE When using the start/stop function keys to control the application it is advisable to enable the communications watchdog, so the drive trips 'TR99', when the communication is lost.

9.13.2 Local Function Keys

The following are defined as local function keys as they are only apply to one or range of pages.

- F10 – Call On-line help. This is only available in the configuration pages and provides information for each parameter displayed on the current page.
- F8 – Parameter Save. This is only available when the parameter save status page is displayed. When pressed will save the parameters within the drive and second processor.

10 Quick Reference

10.1 Application Parameters - Menu 18, Menu 19 and Menu 20

10.1.1 Menu 18

No.	Description	Typ	Units	Range	Default	Setting
18.01	Home State	RO	List	-3 – +5	-	
18.02	Home Complete Flag	RO	Bit	-	-	
18.03	Background Scan Time	RO	Ms	0 – 32000	-	
18.04	Batch Counter (Count Up)	RO	Qty	0 – 32000	-	
18.05	Batch Counter (Count Down)	RO	Qty	0 – 32000	-	
18.06	Batch Done Flag	RO	Bit	-	-	
18.07	Minimum Registration Distance	RO	Units	0 - 32000	-	
18.08	Length of last cut	RO	Units	32000	-	
18.09	Length of cut before last cut	RO	Units	32000	-	
18.10	Line Speed Indication	RO	Units / min * 18.18	32000	-	
18.11	Units	RW	List	0 – 9	0	
18.12	Master Scaling (Denominator)	RW	Units	1 – 32000	1	
18.13	Master Scaling (Numerator)	RW	Counts	1 – 32000	16384	
18.14	Slave Scaling (Denominator)	RW	Units	1 – 32000	1	
18.15	Slave Scaling (Numerator)	RW	Counts	1 – 32000	16384	
18.16	Enable Batch Control	RW	Bit	-	0	
18.17	Batch Quantity	RW	Qty	0 – 32000	10	
18.18	Line Speed Scalar	RW	-	1-32000	1000	
18.19	Home Speed	RW	Units / s	0 – *	5	
18.20	Home Mode	RW	Bit	0 – 1	0	
18.21	Home Back-off Speed	RW	Units / s	0 – *	1	
18.22	Home Search Direction	RW	Bit	-	0	
18.23	Home Accel / Decel	RW	Units / s ²	0 – 32000	50	
18.24	Home Time-out	RW	0.01sec	0 – 32000	500	
18.25	Zero Position Preset	RW	Units	0 – 32000	0	
18.26	Watchdog Trip Delay	RW	ms	0 – 32000	2200	
18.27	Watchdog Output Time Period	RW	ms	0 – 32000	700	
18.28	Jog Speed	RW	Units / s	0 – *	5	
18.29	Jog Acceleration Rate	RW	Units / s ²	0 – 32000	100	
18.30	Jog Deceleration Rate	RW	Units / s ²	0 – 32000	100	
18.31	Home Switch Polarity	RW	Bit	-	1	
18.32	Home Switch Input	RW	Bit	-	-	
18.33	Tool Sync Enable	RW	Bit	-	0	
18.34	Drive Ready	RO	Bit	-	-	
18.35	Enable Feed Forward Term Filter	RW	Bit	-	-	
18.36	Enable High Resolution Alternative Parameters	RW	Bit	-	-	
18.37	Update Scaling	RW	Bit	-	0	
18.38	Batch Reset	RW	Bit	-	0	-
18.39	Acquire Feature Select	RW	Bit	-	0	
18.40	Acquire Bit	RW	Bit	-	-	
18.41	Last Cut Flag	RO	Bit	-	-	
18.42	Tool Output Enable	RO	Bit	-	-	
18.43	Tool Cut Output	RO	Bit	-	-	
18.44	Default Parameters	RW	Bit	-	0	
18.45	Watchdog Enable	RW	Bit	-	0	
18.46	Watchdog In	RW	Bit	-	0	

18.47	Watchdog Out	RO	Bit	-	-	
18.49	System Healthy Output	RO	Bit	-	-	
18.50	Real Time Cut Enable	RW	Bit	-	0	

10.1.2 Menu 19

No.	Description	Typ	Units	Range	Default	Setting
19.01	Position Reference	RO	Units	+/-32000	-	
19.02	Actual Position	RO	Units	+/-32000	-	
19.03	FE Active	RO	Bit	-	-	
19.04	Master Registration Windowing Position	RO	Units	1 - 32000	-	
19.05	Following Error (Units)	RO	0.001 Units	+/-32000	-	
19.06	Following Error (Enc Counts)	RO	Counts	+/-32000	-	
19.07	Flying Shear Status Word	RO	-	-	-	
19.09	Slave Maximum Travel Distance	RO	Units	+/-32000	-	
19.10	Master Position	RO	Units	+/-32000	-	
19.11	FE Limit	RW	0.001 Units	1 – 32000	100	
19.12	Position Loop Velocity Feed Forward Gain	RW	0.001Kd / s	0 – 32000	1000	
19.13	Position Loop Proportional Gain	RW	0.01Kp	0 – 32000	1600	
19.14	Forward Software Limit	RW	Units	0 – 32000	0	
19.15	Reverse Software Limit	RW	Units	0 – 32000	0	
19.16	Proportional Gain Output Limit	RW	Percent of 01.06	0 – 100%	10	
19.17	At Position Tolerance	RW	Units / 1000	0 – 32000	1000	
19.18	CTIU Alarm Word	RO	-	-	-	
19.19	Alarm / Trip Select Word	RW	-	0 – 16383	16383	
19.20	Trip Conditional Select Word	RW	-	0 – 16383	8064	
19.21	Alarm / Trip Enable Word	RW	-	0 – 16383	16383	
19.22	Fault Input Word	RO	-	-	-	
19.23	Gap Length	RW	Units	0 – 32000	0	
19.24	Gap Accel / Decel Rate	RW	Units / s ²	0 – 32000	0	
19.25	Gap Relative Speed	RW	Units / s	0 – 32000	0	
19.26	Cutter IO Mode	RW	Bit	0 – 3	0	
19.27	Cut before start	RW	Bit	-	0	
19.30	First Cut Mode	RW	Bit	0 – 2	0	
19.31	Manual Cut Command	RW	Bit	-	0	
19.32	Drive / Fault Reset	RW	Bit	-	0	
19.33	Shear Run Command	RW	Bit	-	0	
19.34	Go to Start Position	RW	Bit	-	0	
19.35	Local / Remote Select	RW	Bit	-	0	
19.36	Jog Forward	RW	Bit	-	0	
19.37	Jog Reverse	RW	Bit	-	0	
19.38	Home Command	RW	Bit	-	0	
19.39	Abort Motion Command	RW	Bit	-	0	
19.40	Forward Hardware Limit Input	RW	Bit	-	0	
19.41	Reverse Hardware Limit Input	RW	Bit	-	0	
19.42	Hardware Limit Input Polarity	RW	Bit	-	0	
19.43	Disable Limits During Homing	RW	Bit	-	0	
19.44	Change Forward Direction	RW	Bit	-	0	
19.46	Tool Up Input	RW	Bit	-	0	
19.47	Tool Down Input	RO	Bit	-	0	
19.48	Flying Shear Running	RO	Bit	-	0	
19.49	Tool Enable	RO	Bit	-	0	
19.50	Gap Enable	RW	Bit	-	0	

10.1.3 Menu 20

No.	Description	Typ	Units	Range	Default	Setting
20.20	Tool Width Compensation	RW	Units	0 – 32.000	0	
20.21	Minimum Cut Length	RO	Units	-	-	
20.22	Cam Status Word	RO	-	-	-	
20.23	Flying Shear Profile Mode	RW	Bit	-	-	
20.24	Cut Length	RW	Units	1 – 32000	500	
20.25	Shear Length	RW	Units	1 – 32000	1000	
20.26	Fly Accel / Decel Rate	RW	Units / s ²	1 – 32000	50	
20.27	Return Accel / Decel Rate	RW	Units / s ²	1 – 32000	50	
20.28	Maximum Master Velocity	RW	Units / s	1 – 32000	48	
20.29	Settling Time / Accel. Distance	RW	ms / units	0 – 32000	50	
20.30	Cut Time / Sync Distance	RW	ms / units	0 – 32000	50	
20.31	Tool Up Time / Decel. Distance	RW	ms / units	0 – 32000	50	
20.32	Cut Length Fine Adjustment	RW	0.001 Units	0 – 32000	0	
20.33	FE Cut Limit	RW	Counts	1 – 32000	500	
20.34	Fast Deceleration Rate	RW	Units / s ²	1 – 32000	0	
20.35	Ramp Mode	RW	Bit	-	0	
20.36	Cam Pointer Position	RO	-	0 – 10	-	
20.37	Enable Virtual Master	RW	Bit	-	0	
20.38	Virtual Master Speed	RW	Units / s	0 – [20.28]	10	
20.39	Flying Shear Start Position	RW	Units	+/- 32000	0	
20.40	Shear Optimisation Mode	RW	Bit	-	0	
20.41	Flying Shear Type Parallel / Angled	RW	Bit	-	0	
20.42	Registration Fine Offset	RW	0.001 Units	0 – 32000	0	
20.43	Registration Sensor Position	RW	Units	0 – 32000	0	
20.44	Registration Window Enable	RW	Bit	0 – 32000	0	
20.45	Registration Window Tolerance	RW	Units	0 – 32000	20	
20.46	Preset Master Position Command	RW	Bit	-	0	
20.47	Master Preset Position Value	RW	Units	+/- 32000	0	
20.49	Application Software Version	RW	-	0 – 32000	-	

11 Documentation Reference

Manual Description	CT Part Number
Unidrive User Guide	0460 - 0083 - 08
2 nd Encoder Interface User Guide	0460 - 0084
SinCos Interface User Guide	0460 - 0085
Resolver Interface User Guide	0460 - 0088
Unidrive Advanced User Guide	0447 - 1001
Profibus-DP Interface	0460 - 0075
Interbus Interface	0460 - 0076
Modbus-Plus Interface	0400 - 0035
CTNet Interface	0460 - 0025 - 03
Devicenet Interface	0460 - 0077
CAN Interface	0460 - 0063
CANOpen Interface	0460 - 0061
UD70 RS485 Port (CTANSI, Modbus_RTU, custom)	0460 - 0098

12 Signal Interface Unit

12.1 U.T.I.M.

The U.T.I.M. (Universal Type-Interface Module) is a DIN rail mountable unit.

It is designed to help the user by providing conversion between standard signal levels.

It has three channels of conversion - these are:

Channel	Input Signal Type	Output Signal Type
A	+24V (+12 > +25V)	RS-422 and TTL(inv)
B	+24V (+12 > +25V)	RS-422 and TTL(inv)
C 'TTL'	TTL	+24V (equal to supply voltage)
C 'Enable'	+24V	

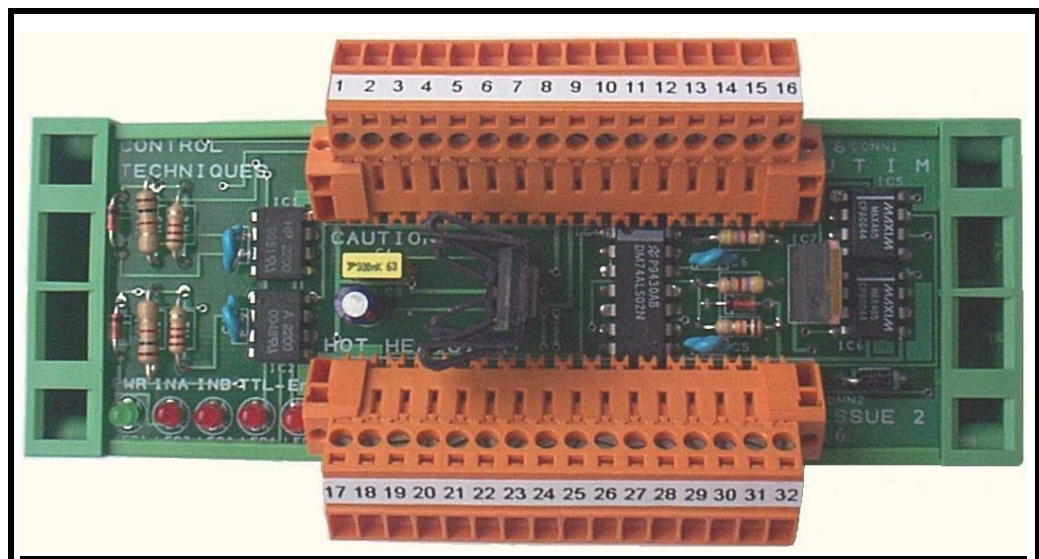

Channels A and B are intended for interfacing a 24volt signal with RS485 / RS422 level inputs or TTL inputs such as those on the UD70. Both inputs are OPTO-isolation from the main circuit for isolation and noise rejection. Channel C is used for converting a TTL level output to a useful 24volt signal that is typically capable of driving sufficient current to operate a solenoid directly or a relay. It is an open-collector type of output and so a load (shunt) resistor will be required if the output is driving a high impedance load. Channel C 'TTL' and 'Enable' inputs do not have OPTO-isolation. The channel C output is inverted with respect to it's (TTL) input and is only enabled when a signal is applied to the 'Enable' input. The 'Enable' input uses positive logic with respect to the channel C output, therefore the 'TTL' input must be LOW and the 'Enable' input must be HIGH in order to derive an output.

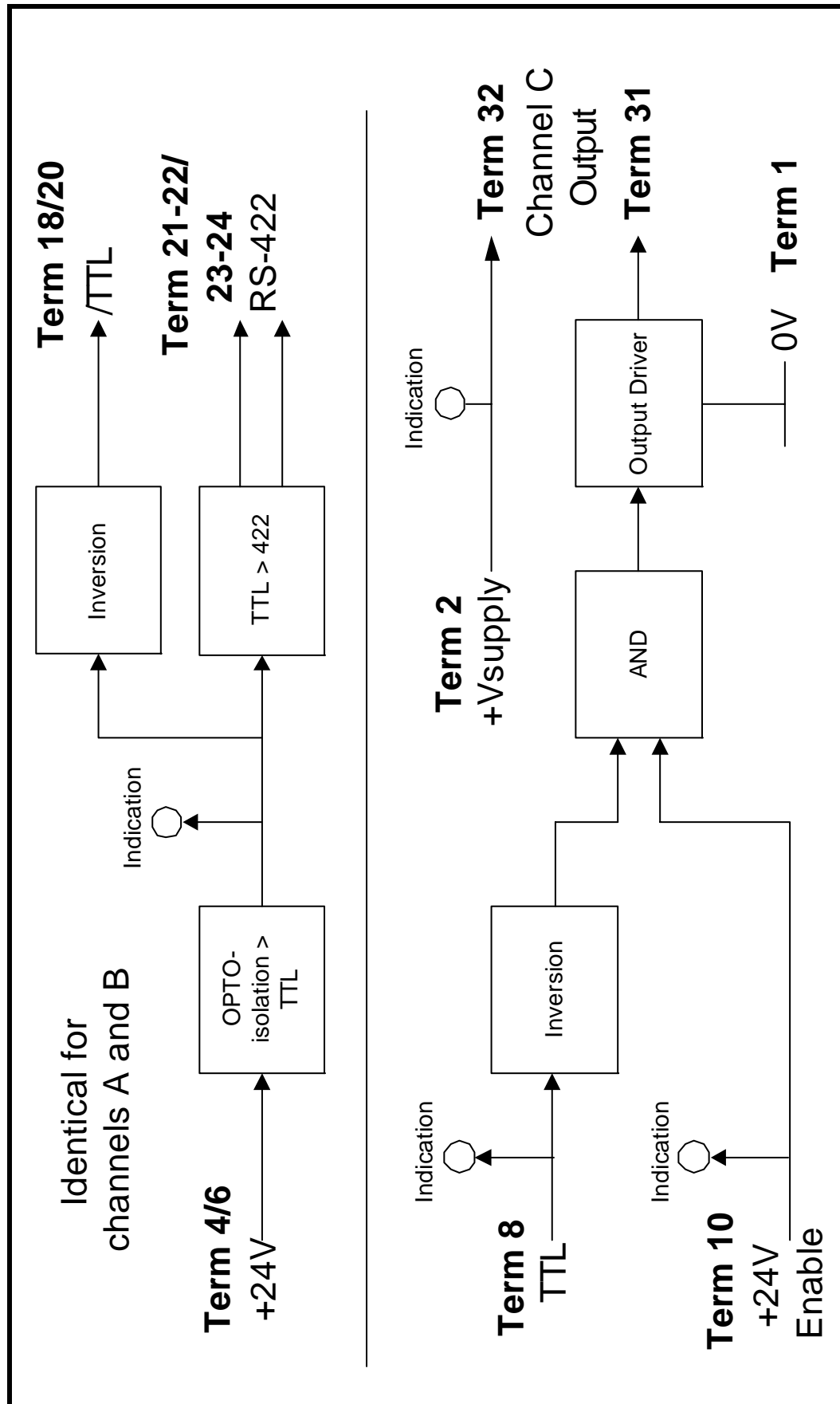

Connector 1			
Terminal	Usage	Polarity	Notes
1	Power in	0V	common*
2	Power in	+V	common**
3	Input A	0V	isolated
4	Input A	+V	isolated
5	Input B	0V	isolated
6	Input B	+V	isolated
7	Input C TTL	0V	common*
8	Input C TTL	+V	
9	Input C +24V	0V	common*
10	Input C +24V	+V	
11	User Vs out	0V	common*
12	User Vs out	+V	common**
13	User Vs out	0V	common*
14	User Vs out	+V	common**
15	User Vs out	0V	common*
16	User Vs out	+V	common**

Connector 2			
Terminal	Usage	Polarity	Notes
17	/TTL out A	0V	common*
18	/TTL out A	+V	
19	/TTL out B	0V	common*
20	/TTL out B	+V	
21	422 out A	-V (inv)	
22	422 out A	+V	
23	422 out B	-V (inv)	
24	422 out B	+V	
25	User Vs out	0V	common*
26	User Vs out	+V	common**
27	User Vs out	0V	common*
28	User Vs out	+V	common**
29	User Vs out	0V	common*
30	User Vs out	+V	common**
31	Ch. C out	0V	
32	Ch. C out	+V	common**

* 0V common

** Vs common

12.2 U.T.I.M. 2

The U.T.I.M. 2 (Universal Type-Interface Module) is a DIN rail mountable unit.

It is designed to help the user by providing conversion between a range of standard signal types, such as +24V, TTL and RS485.

All of the UTIM 2 inputs are optically isolated from the main circuit for electrical isolation and improved noise rejection. They are also electrically isolated from each other.

12.2.1 Logic Diagram

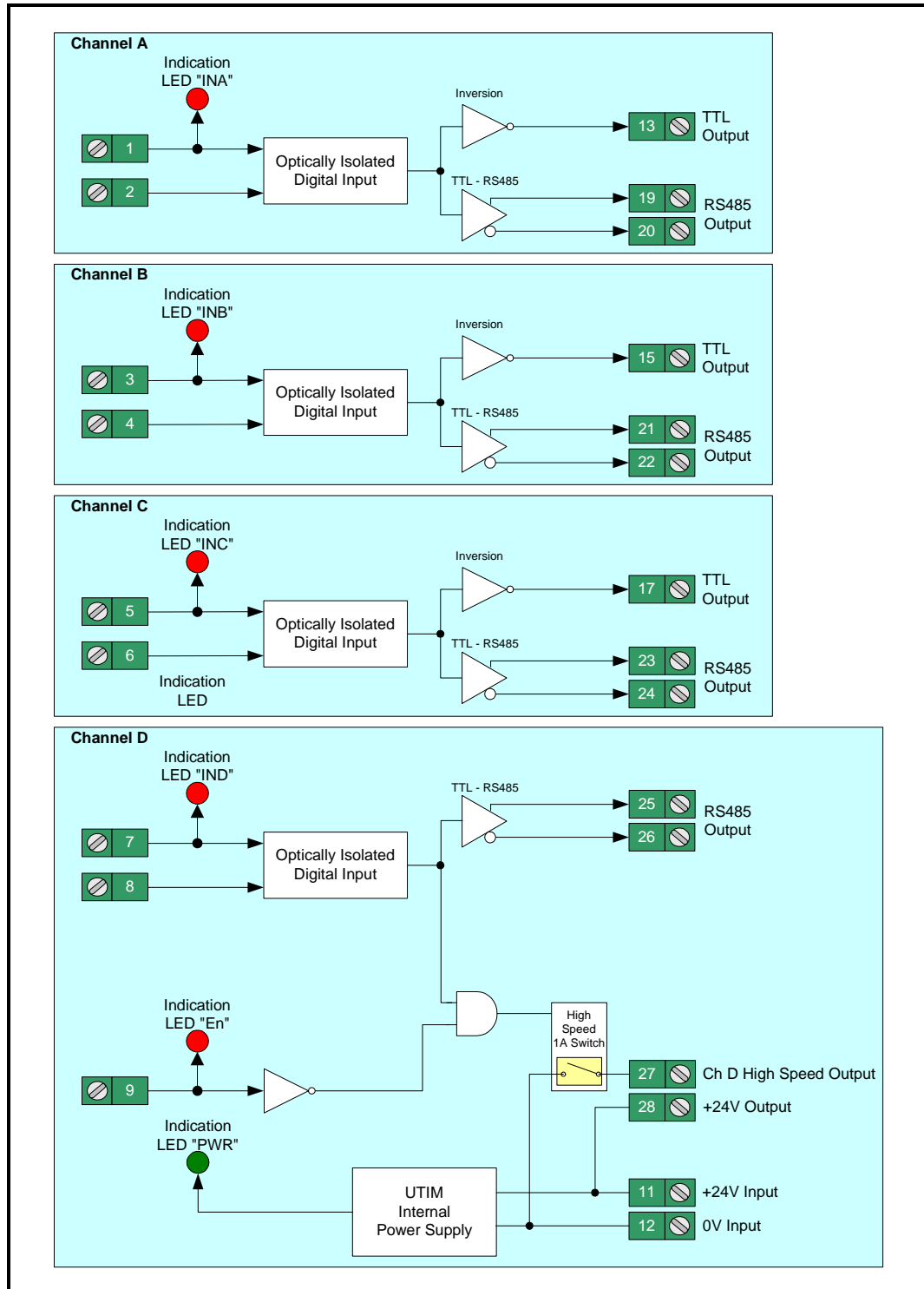

12.2.2 Electrical Installation

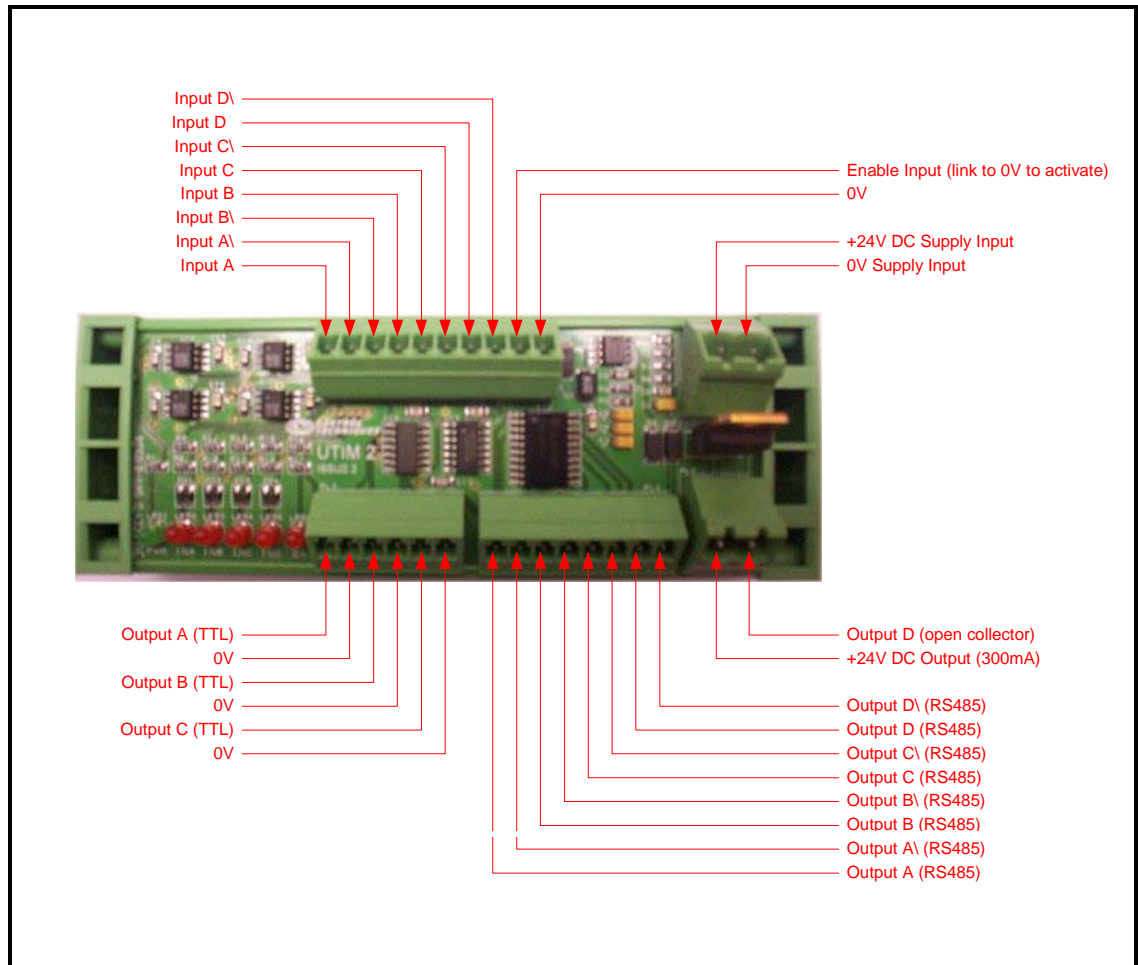

12.2.3 Technical Specification

Parameter	Min	Typical	Max	Units
Supply voltage (VS)	12	24	30	V
Supply current Nominal (Inom)		30		mA
Supply current Inrush (IR)		1		A
Inputs A, B, C, D Voltage	12	24	30	VDC
Inputs A, B, C, D Current	8	10	15	mA
Enable Input Voltage		0		V
Enable Input Current	8	10	15	mA
TTL Outputs A, B, C Frequency			2	MHz
RS422 Outputs A, B, C, D Frequency			2	MHz
Open Collector Output D Frequency			2	MHz
Open Collector Output D Current			1	A
User +V supply current			300	mA
Propagation delay input > TTL out		650		ns
Propagation delay input > RS-485 out		650		ns
Propagation delay input > Open Collector out		650		ns
Operating temperature	0		40	°C
Weight	100			g
Dimensions	127 x 45 x 27			mm

12.2.4 Cable Specification

- All signal cables should be screened type
- Single core screened for singled-end signals (+V in signal, TTL out and open collector out) and twisted pair screened for differential signals (RS485).
- RS485 signals, the screen of the cable should link the 0V on the UTIM to the 0V on the drive.
- Maximum cable length for output signals should be 1metre.
- Maximum length for input signal (+24V) should be 50 metres.