

1 Unidrive SPMC/U (rectifier)

Please refer to the *Unidrive SPM User Guide* for full details of the Unidrive SPMC/U (rectifier) product.

1.1 Introduction

The Unidrive SPMC is a controlled thyristor rectifier and the SPMU is an uncontrolled rectifier.

SPMC1402 and 1601

Figure 1-1 Single half controlled thyristor

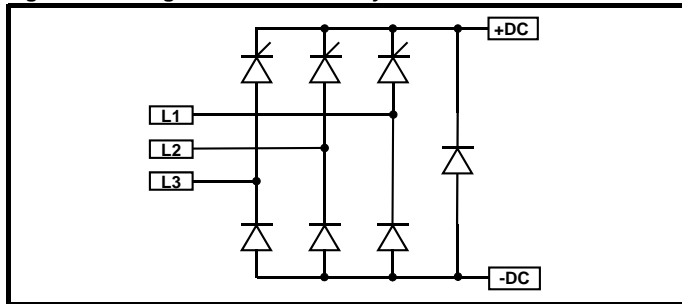

SPMC2402 and 2601

Figure 1-2 Dual half controlled thyristor

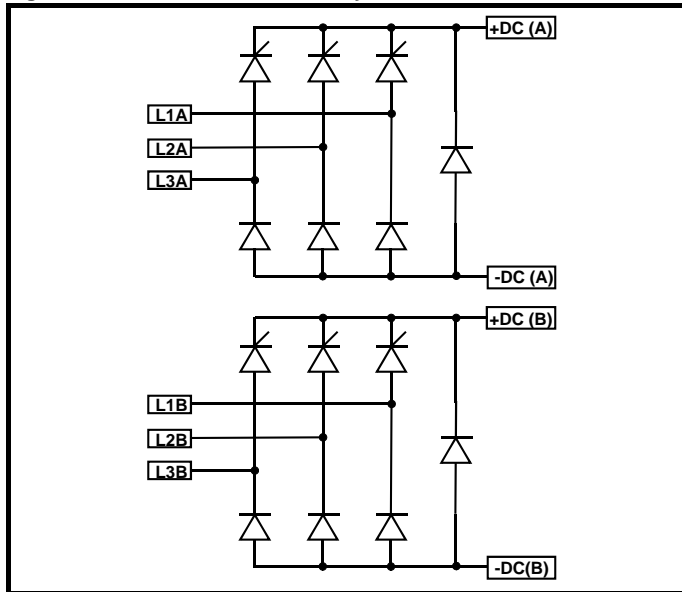

SPMU1402 and 1601

Figure 1-3 Single diode rectifier

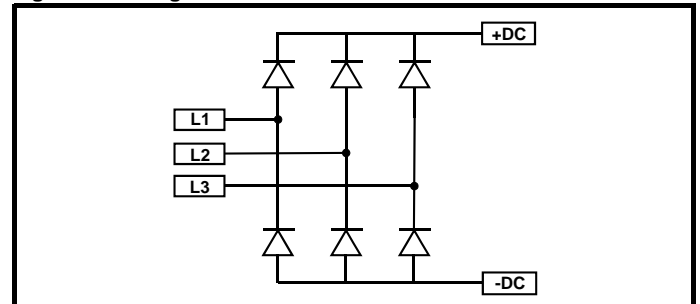

SPMU2402 and 2601

Figure 1-4 Dual diode rectifier

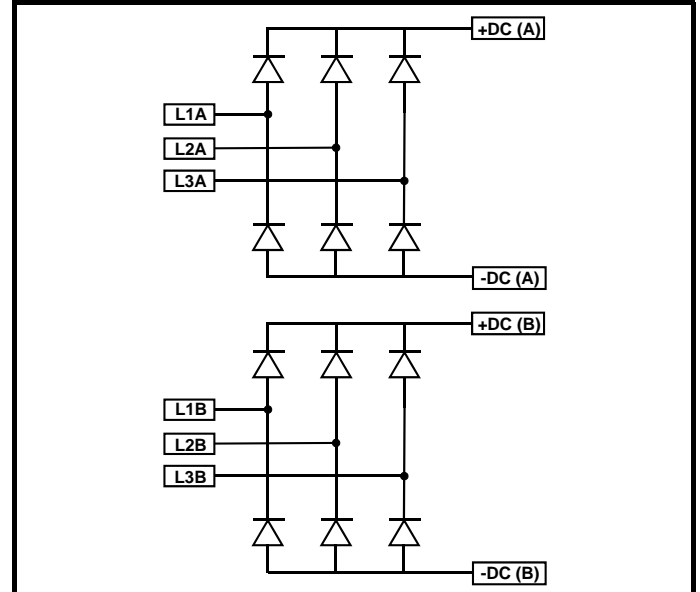

The Unidrive SPMC is a half controlled thyristor bridge is used as a front end to the SPMD inverter module or as a stand alone rectifier for several smaller drives. Soft-start is built in.

The Unidrive SPMU is used as a front end to the SPMD inverter module or as a stand alone rectifier for several smaller drives. **Softstart must be supplied externally using a resistor and contactor or SPMC.**

An external 24V, 3A power supply is required in addition to the AC supply to allow the rectifier to operate. See section *Unidrive SPMC/U external 24V supply requirements* and section *Unidrive SPM power supply* on page 4. Control wiring is required between the rectifier and motoring drive(s) so that if the rectifier indicates a fault the motoring drive(s) will be disabled.

The 24V supply must be protected using a 4A slow-blow fuse, one for each supply pole.

Control connections to the Unidrive SPMC/U should be made with 0.5mm² cable.

The status relay contacts are rated for switching non-inductive loads at 250Vac 6A non-inductive, up to 4Adc if the voltage is limited to 40V or up to 400mA dc if the voltage is limited to 250Vdc. Protection from overcurrent must be provided.

Figure 1-5 SPMC/U rating label

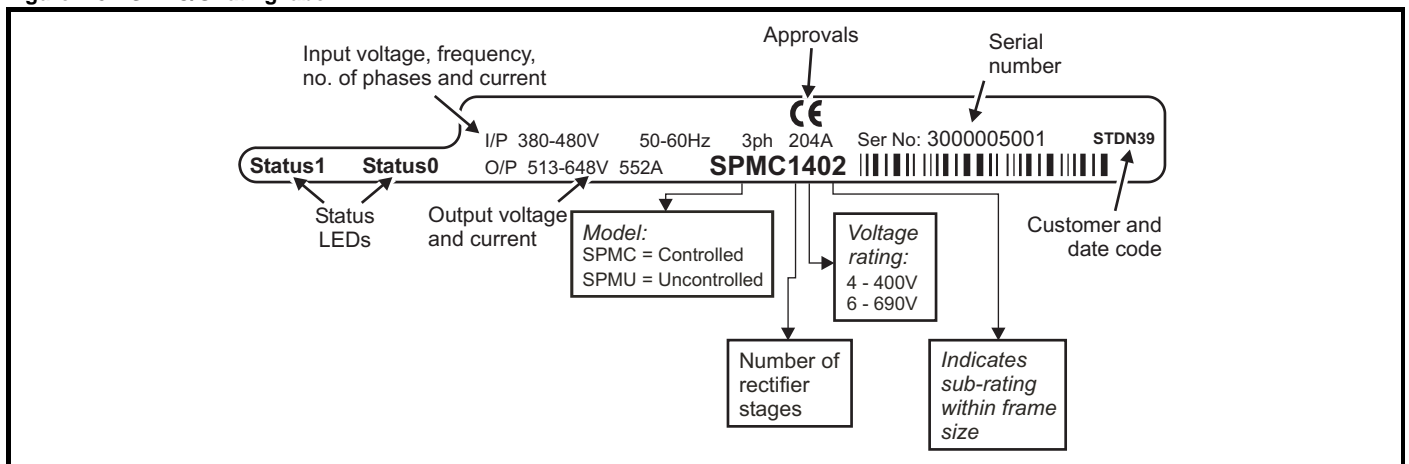

0471-0055-04

1.2 Unidrive SPMC/U technical data

Table 1-1 Unidrive SPMC/U 400V input current, fuse and cable size ratings





Model	Typical input current A	Maximum AC input current A	Typical DC output current A	Semiconductor fuse in series with HRC fuse		Cable sizes				
				HRC IEC Class gG UL class J A	Semi-conductor IEC class aR A	AC input		DC output cable		Cable installation method
				mm ²	AWG	mm ²	AWG			
 SPMC/U1402	339	344	379	450	400	2 x 120	2 x 4/0	2 x 120	2 x 4/0	B1 or C
 SPMC/U2402	2 x 308	2 x 312	2 x 345	450	400	2 x 120	2 x 4/0	2 x 120	2 x 4/0	B1 or C

Table 1-2 Unidrive SPMC/U 690V input current, fuse and cable size ratings

Model	Typical input current A	Maximum AC input current A	Typical DC output current A	Semiconductor fuse in series with HRC fuse		Cable sizes				
				HRC IEC Class gG UL class J A	Semi-conductor IEC class aR A	AC input		DC output cable		Cable installation method
				mm ²	AWG	mm ²	AWG			
 SPMC/U1601	192	195	209	250	250	2 x 70	2 x 2/0	2 x 120	2 x 4/0	B2
 SPMC/U2601	2 x 170	2 x 173	2 x 185	250	250	2 x 70	2 x 2/0	2 x 120	2 x 4/0	B2

Installation class (ref: IEC60364-5-52:2001)

- B1 - separate cables in conduit
- B2 - multicore cable in conduit
- C - multicore cable in free air.



WARNING: The user must provide a means of preventing live parts from being touched. A cover around the electrical connections at the top of the inverter and the bottom of the rectifier where the cables enter is required.

WARNING: Input fuses as specified must be provided.

WARNING: The Unidrive SPMC/U depends on the drive for protection. Status outputs must be linked to the drive enable circuit to ensure that when the rectifier indicates a fault the motoring drive(s) is disabled.

CAUTION: A separate input line reactor of at least the value shown in Table 1-3 must be used with the rectifiers. Failure to provide sufficient reactance could damage or reduce the service life of the rectifier or inverter.

Table 1-3 Matching line reactor to SPMC/U

SPM modules	Model	Current A	Width (W) mm	Depth (D) mm	Height (H) mm	Weight kg	Part number
SPMC/U1402 with SPMD1401/1402	INL401	245	240	190	225	32	4401-0181-00
SPMC/U1402 with SPMD1403/1404	INL402	339	276	200	225	36	4401-0182-00
SPMC/U1601 with SPMD1601/1602	INL601	145	240	190	225	33	4401-0183-00
SPMU1601 with SPMD1603/1604	INL602	192	276	200	225	36	4401-0184-00
SPMC/U2402 with 2 x SPMD1401/1402	INL411	2x 245	320	220	360	55	4401-0206-01
SPMC/U2402 with 2 x SPMC/U1403/1404	INL412	2x 339	320	220	360	55	4401-0207-01
SPMC/U2601 with 2 x SPMC/U1601/1602	INL611	2x 145	220	220	360	40	4401-0190-03
SPMC/U2601 with 2 x SPMC/U1603/1604	INL612	2x 192	220	220	360	55	4401-0191-03

Figure 1-6 Accessories supplied with SPMC/U

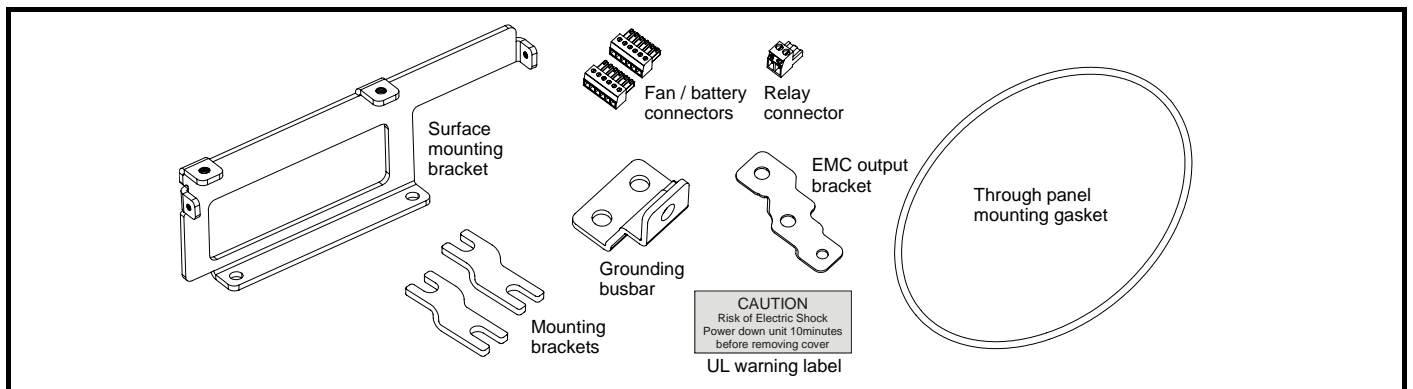

0471-0055-04

Table 1-4 Key to SPMC (rectifier) LEDs

Status Output		Meaning
1: Left LED	0: Right LED	
OFF	OFF	Mains loss, or 24V supply to the rectifier has been lost
OFF	ON	Phase loss
ON	OFF	Any of the following: <ul style="list-style-type: none"> • Snubber overheating due to excessive cable charging current or supply notching • Rectifier heatsink over temperature • Rectifier PCB over temperature • Status input wire break
ON	ON	System healthy

Table 1-5 Key to SPMU (rectifier) LEDs

Status Output		Meaning
1: Left LED	0: Right LED	
OFF	OFF	24V supply to the rectifier has been lost
OFF	ON	Any of the following: <ul style="list-style-type: none"> • Internal fault • Check that rectifier is an SPMU. This could indicate that unit is an SPMC
ON	OFF	Any of the following: <ul style="list-style-type: none"> • Rectifier heatsink over temperature • Rectifier PCB over temperature • Status input wire break
ON	ON	System healthy

Figure 1-7 Surface mounting the Unidrive SPMC/U (rectifier)

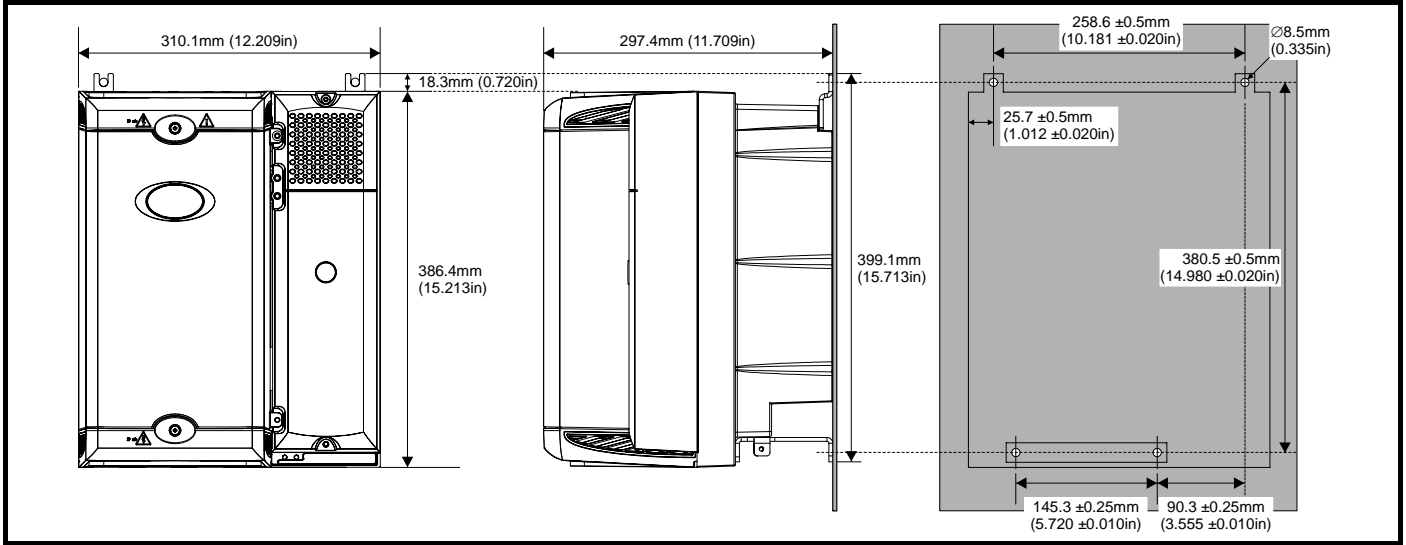

Figure 1-8 Through-panel mounting the Unidrive SPMC/U (rectifier)

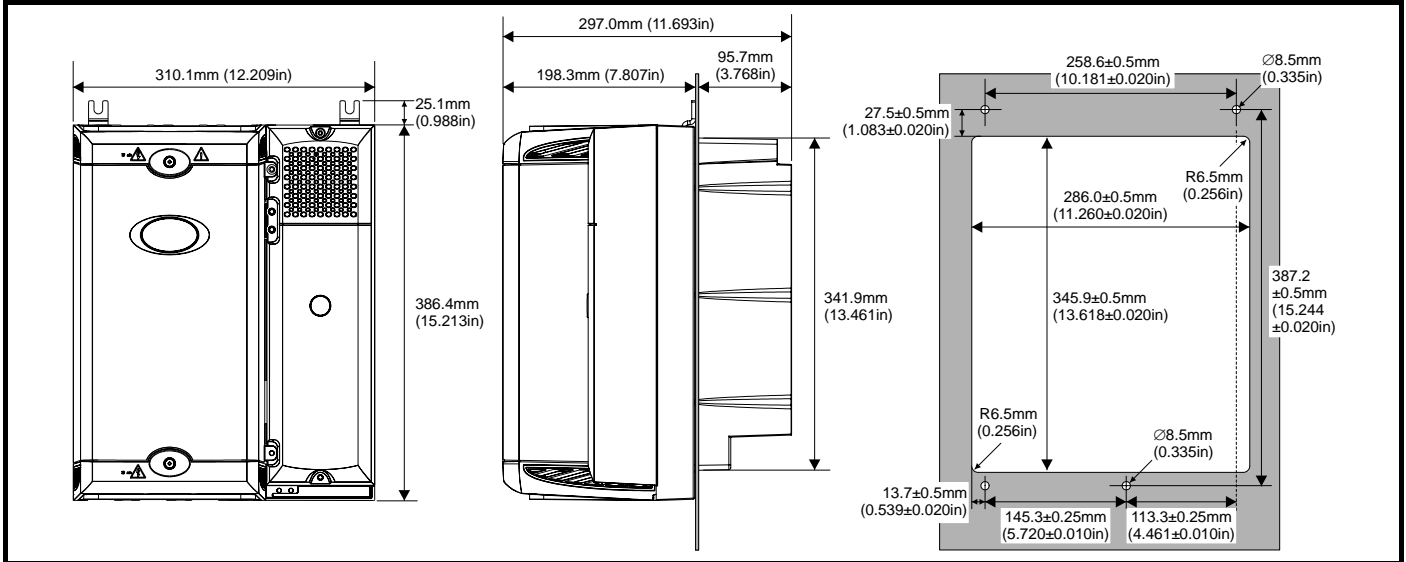

Figure 1-9 Location of control terminals

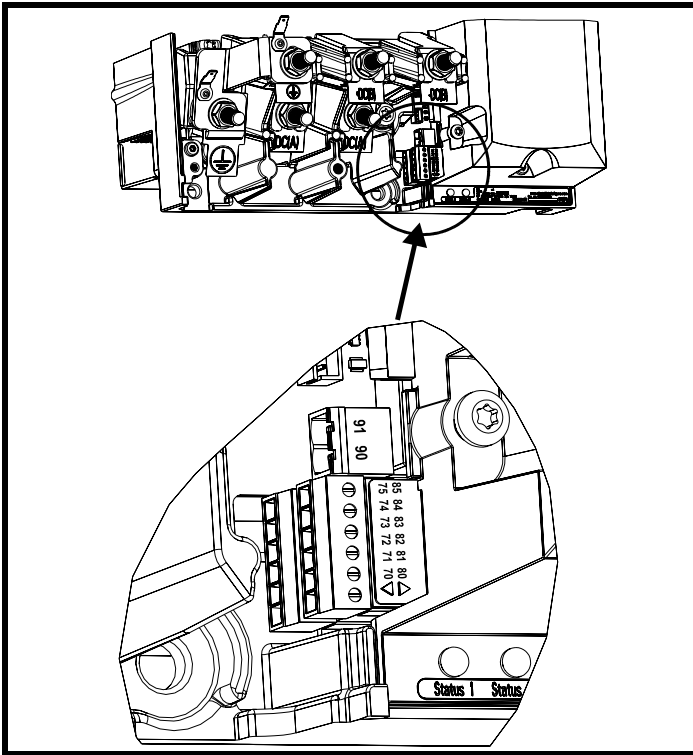

Figure 1-10 Single rectifier control terminals and descriptions

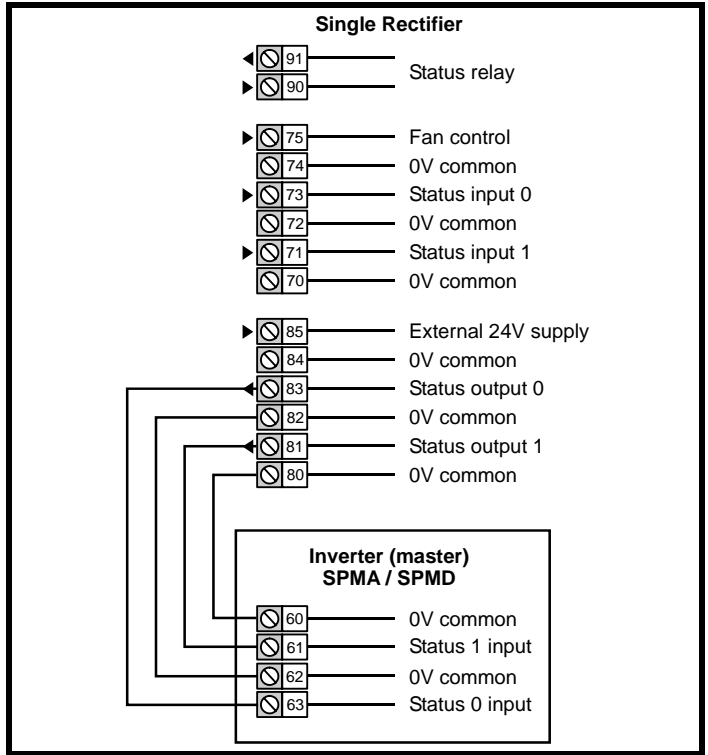
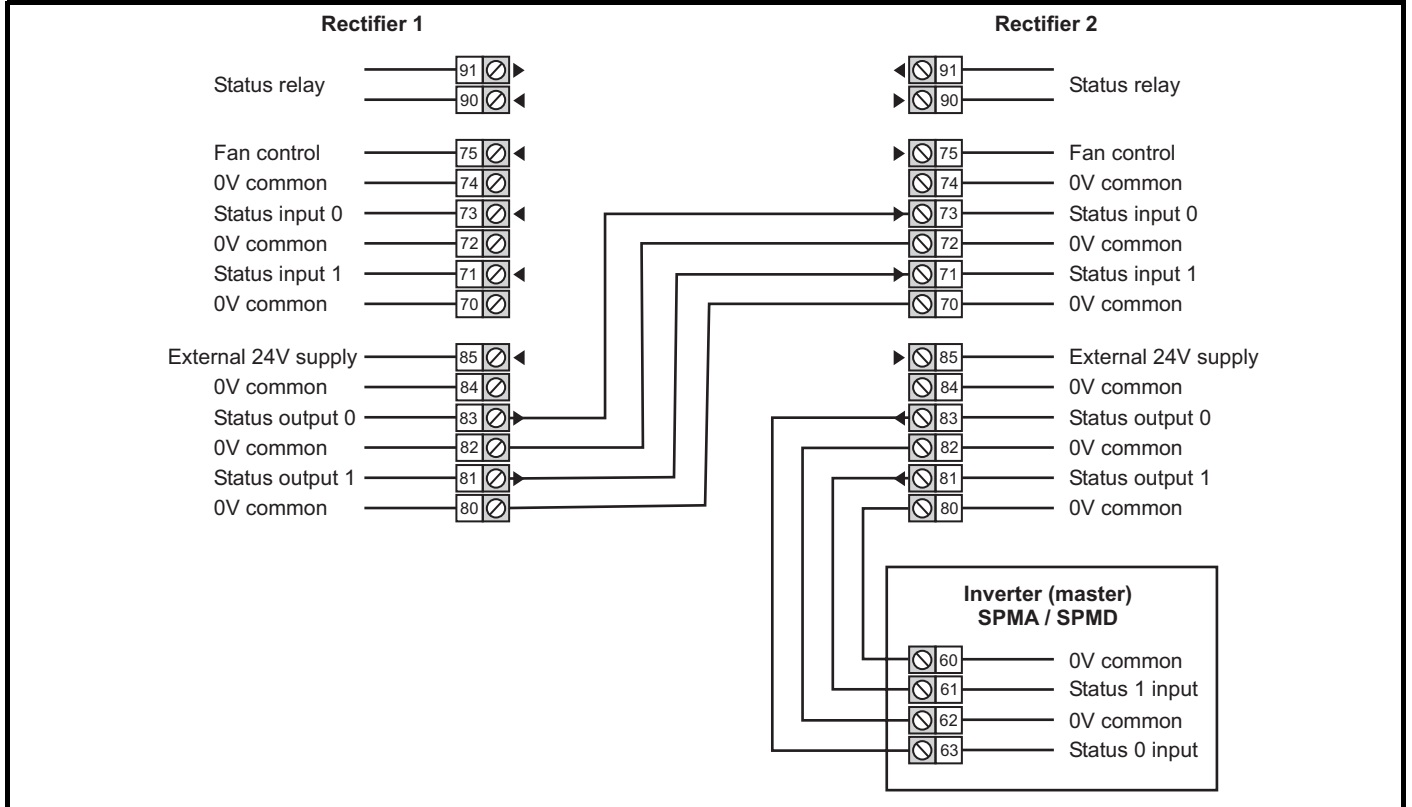

Figure 1-11 Parallel rectifier control terminals and descriptions



Unidrive SPMC/U external 24V supply requirements

- Nominal voltage: 24V
- Minimum voltage: 23V
- Maximum voltage: 28V
- Current drawn: 3A
- Minimum start-up voltage: 18V
- Recommended power supply: 24V, 100W, 4.5A
- Recommended fuse: 4A fast blow ($I^2t < 20A^2s$)

Unidrive SPM power supply

- CT part number: 8510-0000
- Current rating: 10A
- Input voltage: 85 to 123 / 176 to 264Vac auto switching
- Cable size: 0.5mm² (20AWG)
- Fuse: 5A slow-blow from supply

SPMC/U docking kit

The docking kit is used to mount the SPMC/U and SPMD together. The part number of the docking kit is 3470-0012. Consult the *Unidrive SPM User Guide* for more information

NOTE

If the Unidrive SPM power supply (CT part number 8510-0000) is used to supply the Unidrive SPMA/D or SPMC/U, a fuse on the 24V supply to the SPMC/U is not required.

