



# DY5

## Electronic Motor Brake

The **DY5** unit is an electronic AC motor brake. Installation is simple and fast. Only four power wires are needed, plus five interconnecting leads to the existing starter. Use the DY5 to stop AC motors safely and quickly.

DY5 brakes can be applied to most full voltage electromechanical starters and solid state soft starts, and can be ordered as an installed option on a Saftronics soft starter.

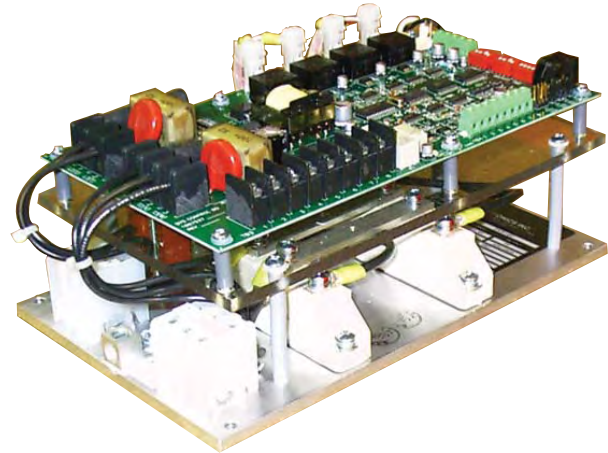

Soft Starters

DY5 Digital Electronic Motor Brakes utilize a microprocessor and 4-SCR Full Wave Bridge to apply regulated DC current to the stator of an AC induction motor causing controlled braking. The DY5 employs zero speed sensing to automatically remove braking current as soon as the motor stops, thus minimizing motor heating and idle time before restarting. The DY5 is designed specifically for applications requiring smooth, rapid braking to reduce motor stopping time and help meet OSHA safety standards. Universal Input Voltage allows the DY5 to operate at line voltages from 200 to 600 VAC and line frequencies between 45 and 65 Hz. PC programmable for custom applications and braking curves.

**NOTE:** *Electronic indication should never be used as the only indication that it is safe to proceed. Zero speed should be mechanically or visually verified and the machine locked out before proceeding with any operation in which movement of the machine would pose a risk.*

- **Universal Input Voltage**
- **Zero Speed Detection**
- **SMD Technology**
- **Switch Mode Power Supply**
- **Closed loop current feedback**
- **Digital Timer**
- **Common Control Module**
- **SCR with 1600V PIV Rating**
- **MOV/RC Snubber protection**
- **Diagnostics LED's**
  - Control Power
  - Motor On
  - Brake On
  - Zero Speed Pulse
- **PC Programming Connection (Optional)**
- **Braking Current: 40-200% Brake Rating**
- **Backup Timer: 1-255 seconds via DIP switch**
- **Zero speed hold time: 0.5-7.5 seconds (delays release of brake after zero speed is sensed) via DIP switch**

### RATINGS, WEIGHTS & DIMENSIONS

Model	Maximum Horsepower by Voltage					Chassis			NEMA 12		
	208V	230V	460V	575V	Amps	Order Code	Dimensions H x W x D (inches)	Weight (lbs)	Order Code	Dimensions H x W x D (inches)	Weight (lbs)
DY5 - 15	3	5	10	15	15	<b>3920-01</b>	9.5 x 6.25 x 5.25	7	<b>3920-02</b>	16 x 14 x 10	32
DY5 - 40	10	15	30	40	40				<b>3921-02</b>		
DY5 - 75	20	25	50	75	75	<b>3922-01</b>	10 x 7.5 x 6	8	<b>3922-02</b>	16 x 14 x 10	33
DY5 - 125	40	50	100	125	125	<b>3923-01</b>	13 x 7.5 x 7	17	<b>3923-02</b>	24 x 20 x 12	72
DY5 - 180	60	75	150	200	180				<b>3924-02</b>		
DY5 - 480	150	200	400	500	480	<b>3925-01</b>	15.25 x 14 x 10	35	<b>3925-02</b>	30 x 24 x 16	115
DY5 - 720	250	300	600	700	720	<b>3926-01</b>	20 x 17 x 12.5	54	<b>3926-02</b>	36 x 30 x 16	175



## SPECIFICATIONS:

<b>Operating Conditions</b>	
Horsepower	3 thru 700 hp
Current range	15A-720A (nominal)
Line Voltage	3 hp, 200 – 600VAC
Supply Frequency	45 to 65Hz
Control Voltage	120VAC 45 to 65Hz, 20VA
Enclosure	Chassis or NEMA12
Ambient Temperature	0 – 40°C (32°F - 104°F) (Operating)
Altitude	1000m (3,300 ft)
Relative Humidity	5% to 95% Non-condensing

<b>Standard Features</b>	
Control	Full Wave Controlled
Overload Capacity	200% for 60 seconds
Duty Cycle	One 30 second stop every 15 minutes at maximum current. Consult factory for suitability of other duty cycles.

<b>Outputs</b>	
Relay Outputs	5A @ 250VAC
Open Collector	24VDC, 50mA

## DY5 WIRING DIAGRAMS:

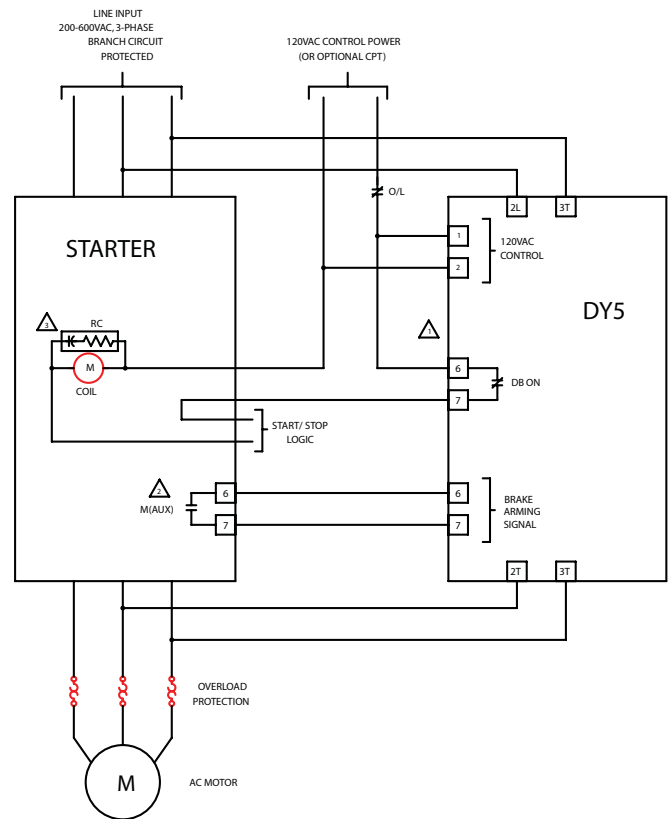

- ⚠️ 1 Interlock to prevent motor starter closing when DY5 is operating.
- ⚠️ 2 Auxiliary interlock to indicate when motor starter is closed.
- ⚠️ 3 Motor starter coil must be suppressed.