

ABB Drives

Installation and Start-up Guide

PROFIBUS Adapter Module
NPBA-12



PROFIBUS Adapter Module
NPBA-12

**Installation and
Start-up Guide**

3BFE 64341588 R0125 REV A

EFFECTIVE: 01.01.2001
SUPERSEDES: 11.08.2000

Safety Instructions

Overview

This chapter states the safety instructions that must be followed when installing and operating the NPBA-12 PROFIBUS Adapter Module. The material in this chapter must be studied before attempting any work on, or with, the unit.

Warnings and Notes

This manual distinguishes two sorts of safety instructions. Warnings are used to inform of conditions which can, if proper steps are not taken, lead to a serious fault condition, physical injury and death. Notes are used when the reader is required to pay special attention or when there is additional information available on the subject. Notes are less crucial than Warnings, but should not be disregarded.

Warnings

Readers are informed of situations that can result in serious physical injury and/or serious damage to equipment with the following symbols:



Dangerous Voltage Warning: warns of situations in which a high voltage can cause physical injury and/or damage equipment. The text next to this symbol describes ways to avoid the danger.



General Warning: warns of situations which can cause physical injury and/or damage equipment by means other than electrical. The text next to this symbol describes ways to avoid the danger.



Electrostatic Discharge Warning: warns of situations in which an electrostatic discharge can damage equipment. The text next to this symbol describes ways to avoid the danger.

Notes

Readers are notified of the need for special attention or additional information available on the subject with the following symbols:

CAUTION!

Caution aims to draw special attention to a particular issue.

Note:

Note gives additional information or points out more information available on the subject.

Safety Instructions

General Safety Instructions



WARNING! All electrical installation and maintenance work on the drive should be carried out by qualified electricians.

The drive and adjoining equipment must be properly earthed.

Do not attempt any work on a powered drive. After switching off the mains, always allow the intermediate circuit capacitors 5 minutes to discharge before working on the frequency converter, the motor or the motor cable. It is good practice to check (with a voltage indicating instrument) that the drive is in fact discharged before beginning work.

The motor cable terminals of the drive are at a dangerously high voltage when mains power is applied, regardless of motor operation.

There can be dangerous voltages inside the drive from external control circuits even when the drive mains power is shut off. Exercise appropriate care when working with the unit. Neglecting these instructions can cause physical injury and death.



WARNING! There are several automatic reset functions in the drive. If selected, they reset the unit and resume operation after a fault. These functions should not be selected if other equipment is not compatible with this kind of operation, or dangerous situations can be caused by such action.

More Warnings and Notes are printed at appropriate instances along the text.

Table of Contents

Safety Instructions

Overview	i
Warnings and Notes	i
General Safety Instructions	ii

Table of Contents

Chapter 1 – Introduction to This Guide

Overview	1-1
Intended Audience	1-1
What This Guide Contains	1-1
Conventions Used in This Guide	1-2
Further Information	1-2

Chapter 2 – Overview

Overview	2-1
PROFIBUS	2-1
The NPBA-12 PROFIBUS Adapter Module	2-2
Compatibility	2-3
Delivery Check	2-3
Warranty and Liability Information	2-3

Chapter 3 – Mechanical Installation

Overview	3-1
Mounting Outside the Drive	3-1
Mounting Inside the Drive	3-2

Chapter 4 – Electrical Installation

Overview	4-1
General Cabling Instructions	4-1
Earthing the Module	4-1
DIP Switch Settings	4-2
NPBA-12 Connections	4-3
Drive Connection	4-3
PROFIBUS and Power Connections	4-3

*Table of Contents***Chapter 5 – Programming**

Overview	5-1
Configuring the System	5-1
PROFIBUS Connection Configuration	5-1
Control Locations	5-4

Chapter 6 – Communication

Overview	6-1
PROFIBUS-DP	6-1
Service Access Points	6-1
Communication Start-up	6-1
PPO Message Types	6-5
The Control Word and the Status Word	6-6
References	6-6
Actual Values	6-6
Parameters in Cyclic Communication (DP)	6-10
Parameters in Acyclic Communication (DPV1)	6-12

Chapter 7 – Fault Tracing

Status LED Indications	7-1
------------------------------	-----

Appendix A – PROFIBUS Parameters**Appendix B – Definitions and Abbreviations**

PROFIBUS Definitions	B-1
PROFIBUS Abbreviations	B-3

Appendix C – Technical Data

DDCS Link	C-1
Fieldbus Link	C-2
NPBA-12	C-3

Appendix D – Ambient Conditions

Ambient Conditions, Operation	D-1
Ambient Conditions, Storage	D-1
Ambient Conditions, Transportation	D-1

Chapter 1 – Introduction to This Guide

Overview

This chapter contains a description of the *Installation and Start-up Guide* for the NPBA-12 PROFIBUS Adapter Module.

Intended Audience

The Guide is intended for the people who are responsible for installing, commissioning and using a PROFIBUS Adapter Module with an ABB drive. The reader is expected to have a basic knowledge of electrical fundamentals, electrical wiring practices, the drive, the use of the drive control panel, and the PROFIBUS protocol family.

What This Guide Contains

The installation and start-up of the NPBA-12 PROFIBUS Adapter Module are introduced in this Guide.

It is assumed that the drive is installed and ready to operate before starting the installation of the adapter module. For more information on the installation and start-up procedures of the drive, please refer to its user documentation.

Safety Instructions are featured in the first few pages of this Guide. Safety Instructions describe the formats for various warnings and notations used within this Guide. This chapter also states the safety instructions which apply to the installation and operation of the NPBA-12 Module.

Chapter 1 – Introduction to This Guide contains a short description of the Guide.

Chapter 2 – Overview contains a short description of the PROFIBUS protocol and the NPBA-12 PROFIBUS Adapter Module, a delivery checklist, and information on the manufacturer's warranty.

Chapter 3 – Mechanical Installation contains placing and mounting instructions for the module.

Chapter 4 – Electrical Installation contains wiring, bus termination and earthing instructions.

Chapter 5 – Programming explains how to program the master station and the drive before the communication through the adapter module can be started.

Chapter 6 – Communication contains a description of how data is transmitted through the NPBA-12 Module.

Chapter 7 – Fault Tracing explains how to trace faults with the Status LEDs on the NPBA-12 Module.

Chapter 1 – Introduction to This Guide

Appendix A presents the PROFIBUS Profile-specific parameters.

Appendix B explains definitions and abbreviations concerning the PROFIBUS protocol family.

Appendix C contains Technical Data.

Appendix D contains a specification of the ambient conditions allowed during transportation, storage and use of the NPBA-12.

Conventions Used in This Guide

<i>Communication Module</i>	Communication Module is a parameter name/parameter selection name for a device (e.g. a fieldbus adapter) through which the drive is connected to an external serial communication network (e.g. a fieldbus). The communication with the communication module is activated with a drive parameter.
<i>Data Sets and Data Words</i>	Data sets are clusters of data sent through the DDCS link between the NPBA-12 Adapter Module and the drive. Each data set consists of three 16-bit words, ie. data words. The Control Word (sometimes called the Command Word) and the Status Word, References and Actual Values (see <i>Chapter 6</i>) are types of data words; the contents of some data words are user-definable.
<i>NPBA-12 PROFIBUS Adapter Module</i>	The NPBA-12 Adapter Module is one of the optional fieldbus adapter modules available for ABB drives. The NPBA-12 is a device through which an ABB drive is connected to a PROFIBUS serial communication bus.
<i>Parameter</i>	A parameter is an operating instruction for the drive. Parameters can be read and programmed with the drive control panel, or through the NPBA-12 Module.

Further Information

Further information is available on the World Wide Web from www.profibus.com.

Chapter 2 – Overview

Overview

This chapter contains a short description of the PROFIBUS standard and the NPBA-12 Adapter Module, a delivery checklist, and warranty information.

PROFIBUS

PROFIBUS is an open serial communication standard that enables data exchange between all kinds of automation components. There are three main variations of PROFIBUS: PROFIBUS-FMS (*Fieldbus Message Specification*), PROFIBUS-DP (*Decentralised Periphery*) and PROFIBUS-PA (*Process Automation*). The NPBA-12 PROFIBUS Adapter Module supports the PROFIBUS-DP and PROFIBUS-DPV1 protocols.

The physical transmission medium of the bus is a twisted pair cable (according to the RS-485 standard). The maximum length of the bus cable is 100 to 1200 metres, depending on the selected transmission rate (see Appendix C). Up to 31 stations can be connected to the same PROFIBUS system without the use of repeaters. With repeaters, it is possible to connect 127 stations (including the repeaters, and the master station) to the system.

In PROFIBUS communication, the master station – usually a programmable logic controller (PLC) – polls the slaves which respond and take the actions requested by the master. It is also possible to send a command to several slaves at the same time; in this case the slaves send no response message to the master. Communication between the slaves is not possible on a PROFIBUS link.

The PROFIBUS protocol family is specified in the EN 50170 Standard. The communication with a drive is discussed in *PROFIDRIVE-PROFILE – The PROFIBUS Profile for Adjustable Speed Drives*. For further information on PROFIBUS, refer to the above-mentioned standards.

**The NPBA-12
PROFIBUS Adapter
Module**

The NPBA-12 PROFIBUS Adapter Module is an optional device for ABB drives which enables the connection of the drive to a PROFIBUS system. The drive is considered as a slave in the PROFIBUS network. Through the NPBA-12 PROFIBUS Adapter Module it is possible to:

- Give control commands to the drive (Start, Stop, Run enable, etc.)
- Feed a motor speed or torque reference to the drive
- Give a process actual value or a process reference to the PID controller of the drive
- Read status information and actual values from the drive
- Change drive parameter values
- Reset a drive fault.

The PROFIBUS commands and services supported by the NPBA-12 PROFIBUS Adapter Module are discussed in Chapter 6. Please refer to the user documentation of the drive as to which commands are supported by the drive.

The adapter module is mounted onto a standard mounting rail inside or outside the drive unit, depending on drive type and configuration. See the user’s manual of the drive for module placement options.

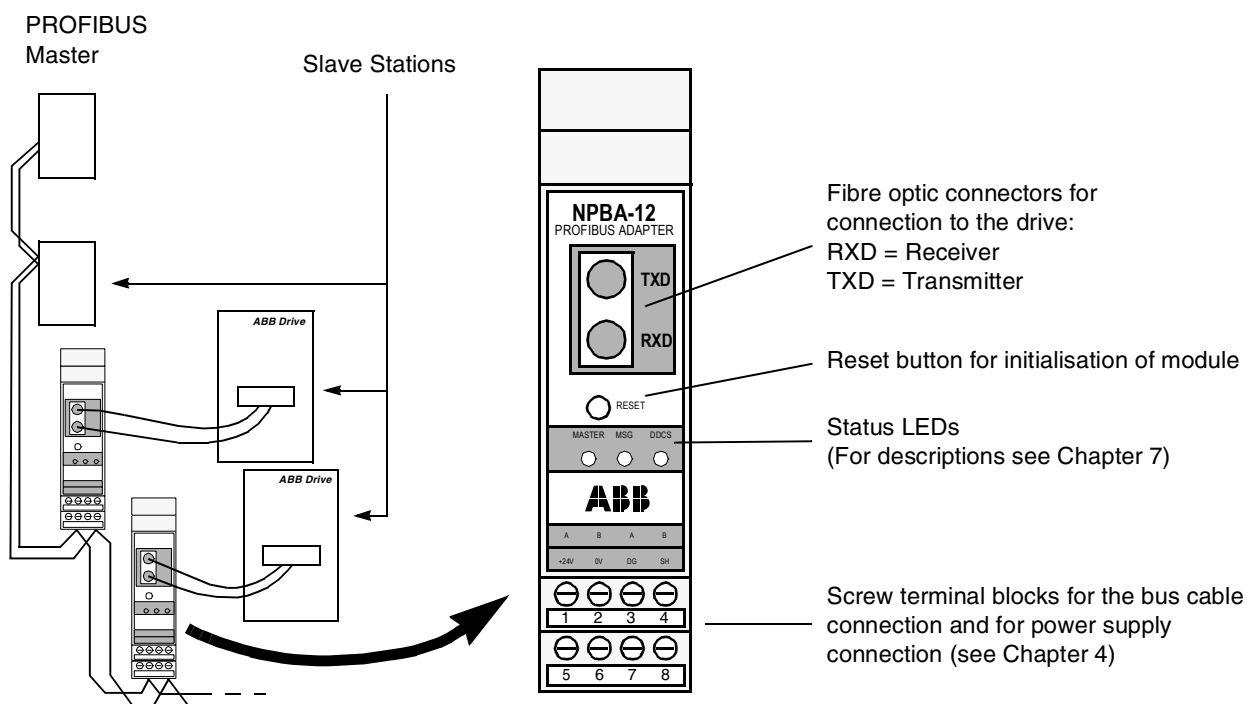

Figure 2-1 The construction of the PROFIBUS link and the NPBA-12 Adapter Module.

Compatibility The NPBA-12 is compatible with (see also Chapter 5, Parameter no. 8 *COMM PROFILE*):

- ACS 400
- ACS 600 SingleDrive
- ACS 600 MultiDrive
- ACS 600 MotionControl (ACP 600)
- ACS 600 CraneDrive (ACC 600)
- ACS 600 Pump and Fan Drive (ACF 600)
- ACS 1000
- DCS 400
- DCS 500
- All master stations that support the PROFIBUS-DP protocol.

Delivery Check The option package for the NPBA-12 PROFIBUS Adapter Module contains:

- PROFIBUS Adapter Module, Type NPBA-12
- Two pairs (four pieces) of fibre optic cables for connecting the adapter to the drive
- Mounting rail
- This manual, the *NPBA-12 Installation and Start-up Guide*.

Warranty and Liability Information

The warranty for your ABB drive and options covers manufacturing defects. The manufacturer carries no responsibility for damage due to transport or unpacking.

In no event and under no circumstances shall the manufacturer be liable for damages and failures due to misuse, abuse, improper installation, or abnormal conditions of temperature, dust, or corrosives, or failures due to operation above rated capacities. Nor shall the manufacturer ever be liable for consequential and incidental damages.

The period of manufacturer's warranty is 12 months, and not more than 18 months, from the date of delivery. Extended warranty may be available with certified start-up. Contact your local distributor for details.

Your local ABB Drives company or distributor may have a different warranty period, which is specified in their sales terms, conditions, and warranty terms.

If you have any questions concerning your ABB drive, contact your local distributor or ABB Drives office.

The technical data and specifications are valid at the time of printing. ABB reserves the right to subsequent alterations.

Chapter 2 – Overview

Chapter 3 – Mechanical Installation

Overview

This chapter contains module mounting instructions. Depending on the drive, the module can be installed either inside or outside the drive housing or cabinet. See the user's manual of the drive for module placement options.

Mounting Outside the Drive

Choose the location for the module. Note the following:

- The cabling instructions in Chapter 4 must be followed.
- The ambient conditions should be taken into account (see Appendix D). The degree of protection of the module is IP 20.
- Observe the free space requirements for the module (see the figure below) and the drive (see the drive documentation).
- Module earth is connected to the mounting rail by means of an earthing tab (see the figure below). The mounting rail onto which the option module is to be mounted must be earthed to a noiseless earth. If the rail is not mounted on a properly earthed base, a separate earthing conductor must be used. The conductor must be as short as possible and its cross-sectional area must be 6 mm^2 at least. **Note:** No solid copper conductor may be used (stranded wire allowed only).

Mounting instructions:

1. Switch off all dangerous voltages in the enclosure that the module is to be mounted in.
2. Fasten the rail and ensure the proper earthing as described above.
3. Push the module onto the rail. The module can be released by pulling the locking spring with a screwdriver (see below).

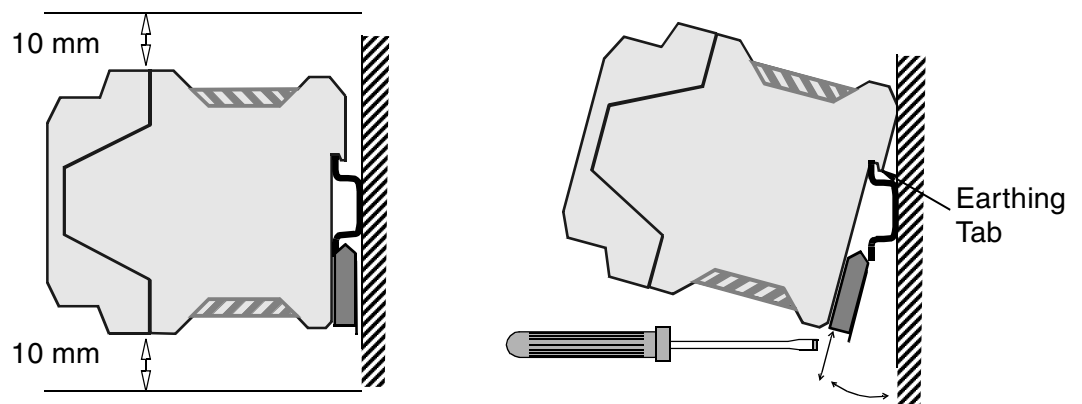

**Mounting Inside
the Drive**

The work inside the drive should be carried out by a qualified electrician only.



WARNING! Pay attention to the slowly discharging voltage of the capacitor bank and the voltages that are connected from external control circuits to the inputs and outputs of the drive.



WARNING! Do not touch the printed circuit boards. The integrated circuits are extremely sensitive to electrostatic discharge.

Mounting instructions:

1. Stop the drive.
2. Switch off the power supply of the drive and all dangerous voltages connected to the inputs and outputs.
3. Wait for five minutes to ensure that the capacitors in the intermediate circuit have discharged.
4. Remove the front cover of the drive.
5. Ensure that the mains cable, motor cable and capacitor bank (UDC+ and UDC–) are not powered.
6. Locate the position for the module (see the drive documentation). Fasten the mounting rail to its place if not already installed. Observe the free space requirements for the module (see the figure above).
7. Push the module onto the rail. The module can be released by pulling the locking spring with a screwdriver (see the figure above).

Chapter 4 – Electrical Installation

Overview

This chapter contains:

- general cabling instructions
- module earthing instructions
- bus termination instructions
- instructions for connecting the module to the drive and to the PROFIBUS bus.



WARNING! Before installation, switch off the drive power supply. Wait five minutes to ensure that the capacitor bank of the drive is discharged. Switch off all dangerous voltages connected from external control circuits to the inputs and outputs of the drive.

General Cabling Instructions

Arrange the bus cables as far away from the motor cables as possible. Avoid parallel runs. Use bushings at cable entries.

Handle fibre optic cables with care. When unplugging optic cables, always grab the connector, not the cable itself. Do not touch the ends of the fibres with bare hands as the fibre is extremely sensitive to dirt.

The maximum long term tensile load for the fibre optic cables is 1 N. The minimum short term bend radius is 25 mm.

Earthing the Module

The NPBA-12 module earth is connected to the rail onto which the module is mounted. If the rail is fastened to an earthed metallic assembly plate, the module is automatically earthed, and no external earthing wire is needed. If the rail is fastened to a base that is not earthed, the rail must be connected to the nearest earthing terminal. However, the earthing wire should not be connected to the same terminal as the power cable screens. (See the mounting instructions in Chapter 3.)

DIP Switch Settings

DIP switch SW1 on the printed circuit board of the NPBA-12 is used to switch on bus termination. Bus termination prevents signal reflections from the cable ends. SW1 should be set to ON if the module is installed at the end of the bus.

Note: The built-in termination circuitry of the NPBA-12 is of the active type, so the module has to be powered for the termination to work. If the module needs to be switched off during operation of the network, the bus can be terminated by connecting a 220 ohm, 1/4 W resistor between the A and B lines.

The DIP switch on the circuit board can be accessed as shown below.

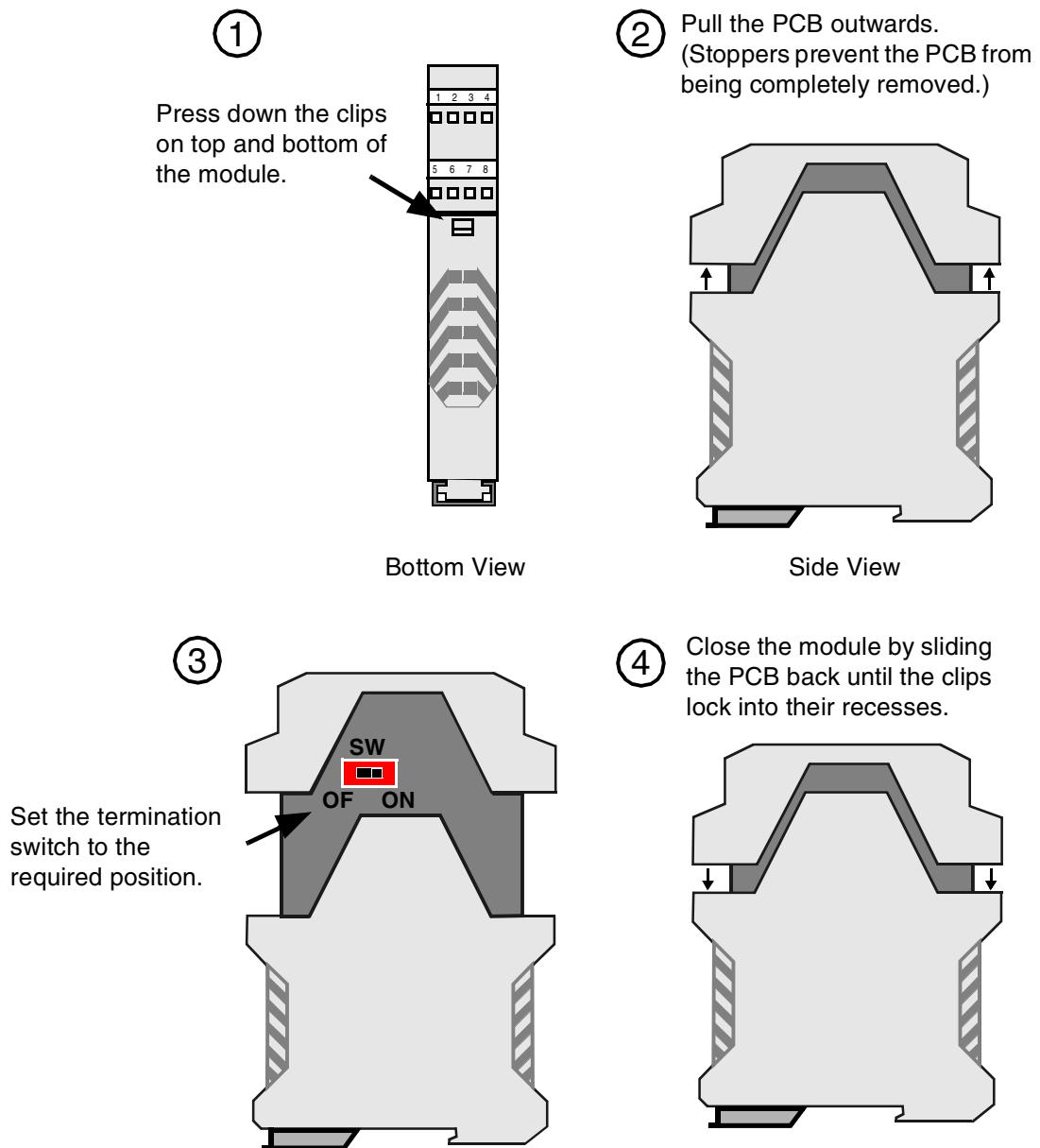

NPBA-12 Connections

Drive Connection

The NPBA-12 module is connected to the drive using a fibre optic cable link. Consult the drive documentation as to the corresponding terminals inside the drive.

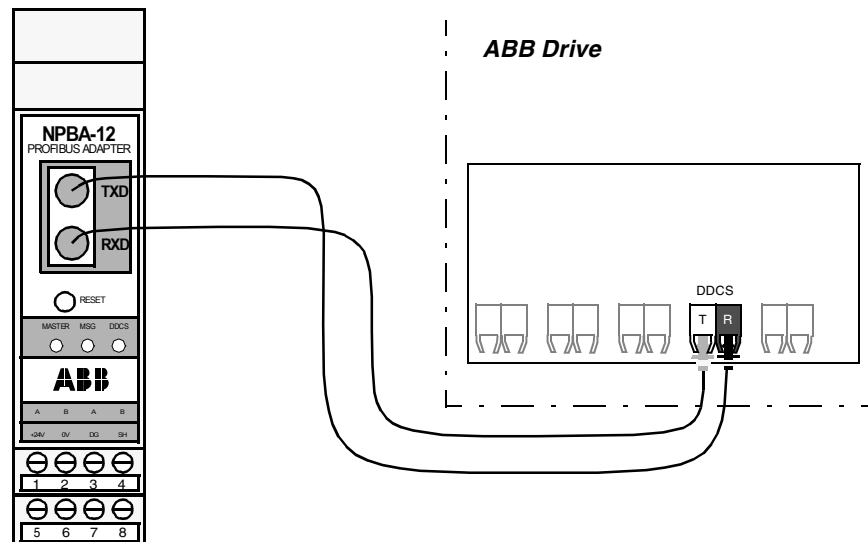

Figure 4-2 Fibre optic link connecting the NPBA-12 to the drive.

PROFIBUS and Power Connections

The bus cable and the external power supply are connected to terminal blocks X1 and X2 on the NPBA-12.

The terminal blocks are described below.

X1		Description
1	A	Data Negative (Conductor 2 in twisted pair).
2	B	Data Positive (Conductor 1 in twisted pair).
3	A	Data Negative (Conductor 2 in twisted pair).
4	B	Data Positive (Conductor 1 in twisted pair).

X2		Description
5	+24V	Power supply for the module (24 V d.c. ±10%). The power can be taken from the drive's internal power supply (see drive manuals), or an external power supply. On-board power supply shuts off if the voltage drops below 11 V.
6	0V	
7	DG	PROFIBUS cable data ground (optional 3rd conductor). Connected to module earth via a 1 MΩ/15 nF RC network.
8	SH	PROFIBUS cable shield. Internally connected to module earth.

Chapter 4 – Electrical Installation

PROFIBUS Wiring Examples

The PROFIBUS cable shield may be directly earthed at one station only. At other stations the cable shield should be earthed via an RC filter.

There are two wiring examples below for standard PROFIBUS cable consisting of a twisted pair and screen.

A

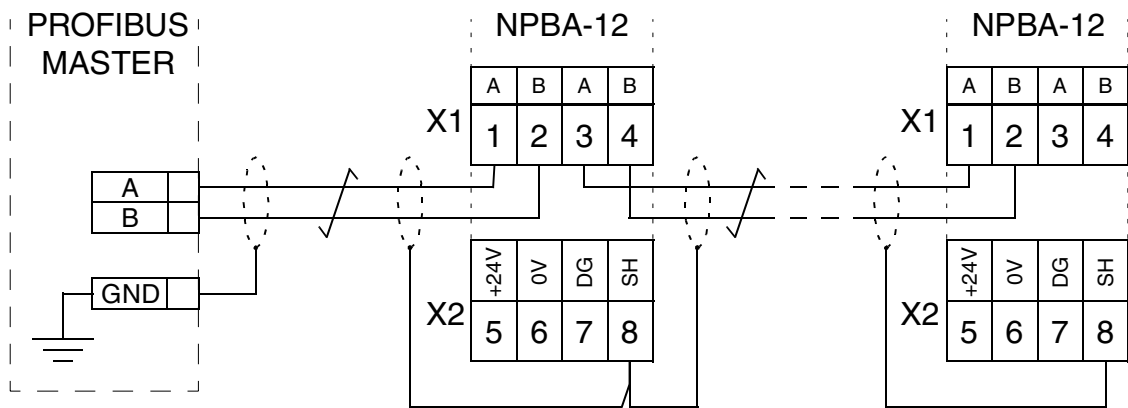

B

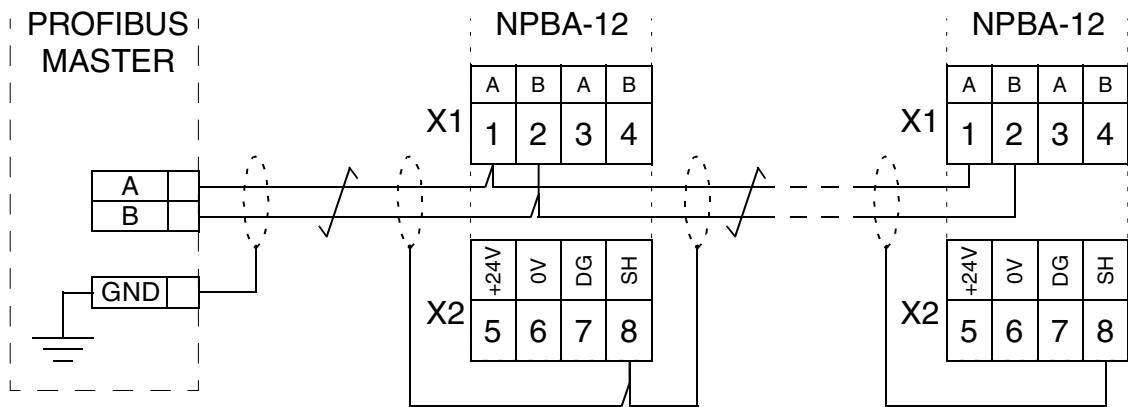

Figure 4-3 Connection diagram for the standard PROFIBUS cable. Only connection (B) enables the removal of the intermediate module without disturbing the bus.

Chapter 5 – Programming

Overview

This chapter gives information on configuring the PROFIBUS master station and the drive for communication through the NPBA-12 PROFIBUS Adapter Module.

Configuring the System

After the NPBA-12 PROFIBUS Adapter Module has been mechanically and electrically installed according to the instructions in Chapters 3 and 4, the master station and the drive must be prepared for communication with the module.

The type definition (GSD) file required for configuration of the master station is available from www.profibus.com or your local ABB representative. The filename is **ABB_6012.GSD**.

Please refer to the master station documentation for more information.

PROFIBUS Connection Configuration

The detailed procedure of activating the module for communication with the drive is dependent on drive type. (Normally, a parameter must be adjusted to activate the communication. See the drive documentation.)

As communication between the drive and the NPBA-12 is established, several configuration parameters are copied to the drive. These parameters – shown below in [Table 5-1](#) – must be checked first and adjusted if necessary. The alternative selections for these parameters are discussed in more detail below the table.

Note: The new settings take effect only when the module is powered up or the RESET button pressed for the next time.

Note: In case the fibre optic cables are transferred from one drive to another without powering down the module, press the RESET button to refresh the configuration parameters in the module.

Note: The grouping, numbering, and adjustment procedure of parameters vary from drive to drive. See the drive documentation for information.

Data Transfer Rates Supported

The NPBA-12 supports the following PROFIBUS communication speeds: 9.6 kbit/s, 19.2 kbit/s, 45.45 kbit/s, 93.75 kbit/s, 187.5 kbit/s, 500 kbit/s, 1.5 Mbit/s, 3 Mbit/s, 6 Mbit/s, 12 Mbit/s.

The NPBA-12 automatically detects the communication speed used.

Chapter 5 – Programming

Table 5-1 The NPBA-12 configuration parameters.

Fieldbus Par. No.	Parameter Name	Alternative Settings	Default Setting
1	MODULE TYPE	(Read-only)	NPBA-12 Vx.x
2	PROTOCOL	(0) DP; (1) DPV1	(0) DP
3	PPO TYPE	(0) PPO 1; (1) PPO 2; (2) PPO 3; (3) PPO 4; (4) PPO 5	(0) PPO 1
4	NODE NUMBER	2 to 126	2
5	NO. OF DATA SETS	1 to 4	1
6	DATA SET INDEX	(0) FBA DSET 1; (1) FBA DSET 10	(0) FBA DSET 1
7	CUT-OFF TIMEOUT	0 to 255	30
8	COMM PROFILE	(0) ABB DRIVES; (1) CSA 2.8/3.0	(0) ABB DRIVES
9	CONTROL ZERO MODE	(0) STOP; (1) FREEZE	(0) STOP

MODULE TYPE This parameter shows the module type and software version as detected by the drive. The value cannot be adjusted by the user.

If this parameter is undefined, the communication between the drive and the module has not been established.

PROTOCOL This parameter selects the protocol used.

DP

This setting can be used with PROFIBUS masters that support the DP or DPV1 protocol.

DPV1

This setting must be used with DPV1-only PROFIBUS masters.

PPO TYPE This parameter selects the PPO message type for the PROFIBUS connection. See [Figure 6-1](#) for available PPO message types.

NODE NUMBER Each device on the PROFIBUS link must have a unique node number. This parameter is used to define a node number for the drive it is connected to.

NO. OF DATA SETS This parameter defines the number of data sets sent in each direction in PPO messages; e.g., if this parameter is set to 1, only data sets 1 (master to drive) and 2 (drive to master) are used. Setting this parameter to 4 enables all eight data sets shown in [Figure 6-1](#): data sets with odd numbers (1,3,5,7) are sent by the master to the drive and those with even numbers (2,4,6,8) are sent by the drive to the master (providing DATA SET INDEX is set to FBA DSET 1). Please note that different drive types support different numbers of data sets; see the drive documentation.

DATA SET INDEX Defines the offset for data set indexes (numbers). See the drive documentation for information.

FBA DSET 1 (no offset)

The first data set sent from the master to the drive (the Control Word) is Data Set 1 (DS1).

FBA DSET 10 (offset 9)

The first data set sent from the master to the drive (the Control Word) is Data Set 10 (DS10).

CUT-OFF TIMEOUT This parameter defines the behaviour of the NPBA module in the event that no messages are received from the PROFIBUS controller.

0

The NPBA cyclically sends the last valid Control Word and References to the drive until new values are received from the controller.

1 ... 255

The NPBA stops communicating with the drive after a timeout, the actual length of which equals the setting multiplied by 20 milliseconds. The behaviour of the drive in case the DDCS communication stops depends on its parameter settings; consult the drive documentation.

Normal operation is resumed after valid messages are again received from the controller.

COMM PROFILE This parameter selects the communication profile used in the DDCS link between the drive and the NPBA-12. The setting to use is dependent on drive type and software version as indicated below. (The drive software version can be checked by viewing a parameter; see the drive documentation.)

Drive Type	Drive SW Version	Setting to Use
ACS 400	1.3.0.E or later	ABB DRIVES
ACS 600 SingleDrive	CSA 2.8x to CSA 3.0x	CSA 2.8/3.0
ACS 600 SingleDrive	ACxA5000 or later	ABB DRIVES
ACS 600 SingleDrive with PFC	AHxA2000 or later	CSA 2.8/3.0
ACS 600 MultiDrive	AMxM103a or later	ABB DRIVES
ACS 600 MotionControl (ACP 600)	APxA1100 or later	ABB DRIVES
ACS 600 Pump & Fan Drive (ACF 600)	AF0A1020 or later	ABB DRIVES
ACS 600 CraneDrive (ACC 600)	ACxA2000 or later	ABB DRIVES
ACS 1000		ABB DRIVES
DCS 400		ABB DRIVES
DCS 500	DC21x226 or later	ABB DRIVES

ABB DRIVES

The NPBA-12 relays the Control Word “as is” from the PROFIBUS master to the drive. The Status Word is relayed to the master as received from the drive, except bit 15 which is used as a DDCS communication error indicator. The Control and Status Word bits are assigned as defined by the ABB Drives Profile (based on the PROFIBUS standard).

CSA 2.8/3.0

The Control Word and the Status Word are altered in order to match the drive Control and Status Words to those defined by the PROFIBUS profile.

CONTROL ZERO MODE

This parameter defines the operation of the NPBA module in the event that only messages consisting of zeros are received from the PROFIBUS controller. This is the case e.g. when the controller is switched from RUN to STOP mode.

STOP

The messages are forwarded to the drive as such. This will usually cause the drive to stop; for more information, consult the drive documentation.

FREEZE

The last-received valid Control Word and References are sent to the drive until new values are received from the PROFIBUS controller.

Control Locations

ABB drives can receive control information from multiple sources including digital inputs, analogue inputs, the drive control panel and a communication module (e.g. NPBA-12). ABB drives allow the user to separately determine the source for each type of control information (Start, Stop, Direction, Reference, Fault Reset, etc.). In order to give the fieldbus master station the most complete control over the drive, the communication module must be selected as source for this information. See the user documentation of the drive for information on the selection parameters.

Chapter 6 – Communication

Overview

This chapter describes the PROFIBUS messaging used in the communication with the drive.

PROFIBUS-DP

The NPBA-12 module supports the PROFIBUS-DP protocol, including the DPV1 Extensions to the EN 50170 standard. PROFIBUS-DP is a distributed I/O system which enables the master to use a large number of peripheral modules and field devices. The data transfer is mainly cyclic: the master reads the input information from the slaves and sends the output information back to the slaves.

The PROFIBUS-DP protocol uses so-called PPOs (*Parameter/Process Data Objects*) in cyclic communication. See [Figure 6-1](#) for the different PPO types and their composition.

Service Access Points

The services of the PROFIBUS Data Link Layer (Layer 2) are used by PROFIBUS-DP through Service Access Points (SAPs). Precisely defined functions are assigned to individual SAPs.

For further information on Service Access Points, refer to the manual of the PROFIBUS master, *PROFIDRIVE – The PROFIBUS Profile for Adjustable Speed Drives*, or the EN 50170 standard.

Communication Start-up

The following Service Access Points (SAPs) are used to initiate DP communication:

SAP No.	Short Name	Name
61	Set_Prm	Send Parameter Data
62	Chk_Cfg	Check Configuration Data
60	Slave_Diag	Read Slave Diagnostic Information
128 (Default)	Data_Exch	Transfer Input and Output Data

SAP 60 (Slave_Diag) This SAP gives diagnostic information on the slave station.

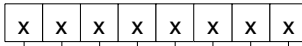
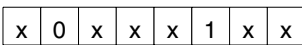
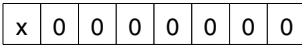
Diag_Data (Diagnostic Data) Type: Octet String - Length: 6 (Standard) + 2 (Extended Diagnosis)	
Byte	Description
1	<p>Station_Status_1</p>  <ul style="list-style-type: none"> Diag.Station_Non_Existent (Set by Master, reset by Slave) Slave not found Diag.Station_Not_Ready (Set by Slave) Slave not ready for data exchange Diag.Cfg_Fault (Set by Slave) Received configuration data does not match original configuration data Diag.Ext_Diag (Set by Slave) Diagnostic entry present in slave-specific diagnostic area Diag.Not_Supported (Set by Slave) Service not supported by slave Diag.Invalid_Slave_Response (Set by Master, reset by Slave) Invalid response by slave Diag.Prm_Fault (Set by Slave) Invalid parameter or parameter value Diag.Master_Lock (Set by Master, reset by Slave) Slave is parameterised by another master
2	<p>Station_Status_2</p>  <ul style="list-style-type: none"> Diag.Prm_Req (Set by Slave) Slave requires re-configuration and re-parameterisation Diag.Stat_Diag (Set by Slave) Static diagnosis. Slave (temporarily) unable to provide valid data Always set to 1 by Slave Diag.WD_On (Set by Slave) Watchdog on Diag.Freeze_Mode (Set by Slave) Freeze command received by slave Diag.Sync_Mode (Set by Slave) Sync command received by slave Reserved Diag.Deactivated (Set by Master, reset by Slave) Slave is inactive
3	<p>Station_Status_3</p>  <ul style="list-style-type: none"> Reserved Diag.Ext_Diag_Overflow (Set by Slave)
4	<p>Diag.Master_Add The address of the master that parameterised this slave</p>
5 to 6	<p>Ident_Number (for NPBA-12: 6012h)</p>

Chapter 6 – Communication

Diag_Data (Diagnostic Data) Type: Octet String - Length: 6 (Standard) + 2 (Extended Diagnosis)	
Byte	Description
7	Ext_Diag_Data The number of bytes reserved for Extended Diagnosis (including this byte) Fixed to 2
8	Ext_Diag_Data 0 = OK 4 = Actual value channel is not updated (last value retained)

SAP 128 (Data_Exchange) Allows the master to send output data to a slave station and to simultaneously request input data from the same station.

Outp_Data (Output Data) Type: Octet String - Length: 0 to 32 (depending on the selected PPO Type)
Inp_Data (Input Data) Type: Octet String - Length: 0 to 32 (depending on the selected PPO Type)

PPO Message Types

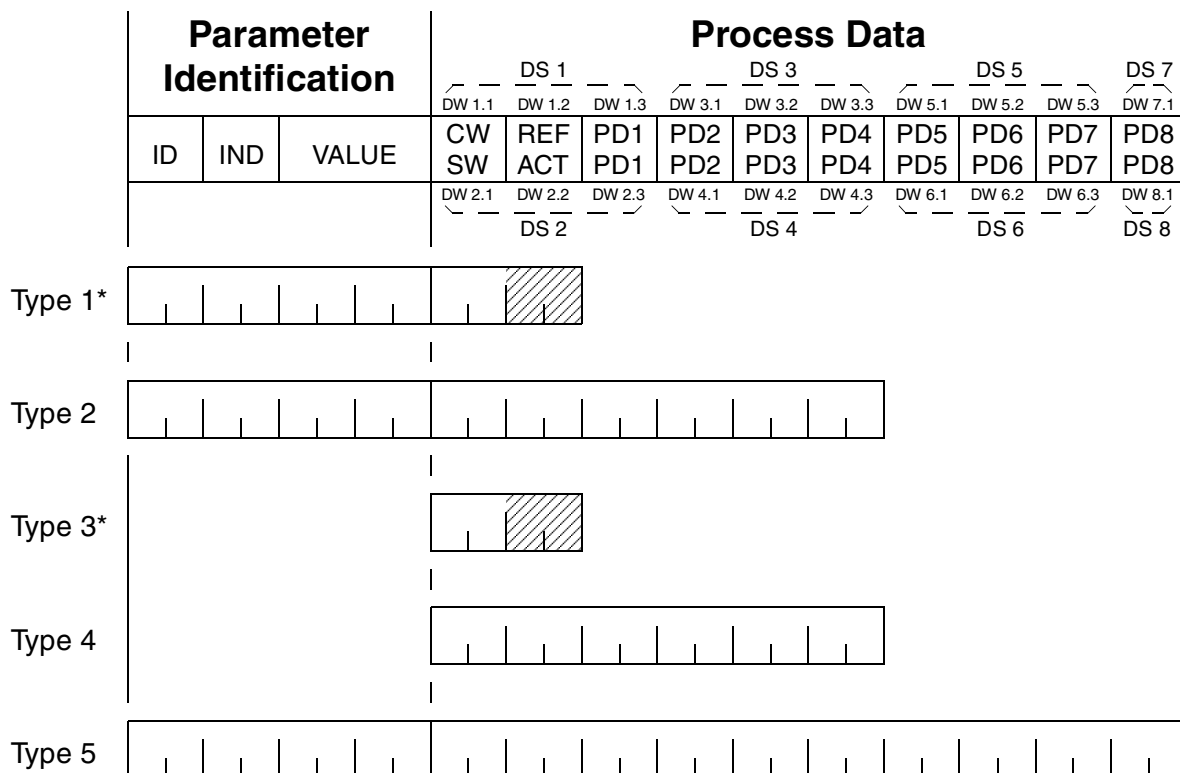

* With ACS 600 using the CSA 2.8/3.0 communication profile, the contents of DW 1.2 and DW 2.2 (shaded) are determined by the active drive control location:
EXT1 selects REF1 / ACT1,
EXT2 selects REF2 / ACT2.

Parameter Identification:
ID – Parameter Identification
IND – Index for Arrays
VALUE – Parameter Value (Max. 4 bytes)

Process Data:
CW – Control Word (from Master to Slave; see Table 6-1)
SW – Status Word (from Slave to Master; see Table 6-2)
REF – Reference (from Master to Slave)
ACT – Actual Value (from Slave to Master)
PD – Process Data (application-specific)
DS – Data Set
DW – Data Word

Figure 6-1 PPO Message Types.

Chapter 6 – Communication

The Control Word and the Status Word

The Control Word (PROFIBUS Parameter 967) is the principal means for controlling the drive from a fieldbus system. It is sent by the fieldbus master station to the drive, the adapter module acting as a link. The drive switches between its states according to the bit-coded instructions on the Control Word, and returns status information to the master in the Status Word (PROFIBUS Parameter 968).

The contents of the Control Word and the Status Word are detailed in [Table 6-1](#) and [Table 6-2](#) respectively; see the drive documentation for information on the drive-specific bits. The drive states are presented in the PROFIBUS State Machine ([Figure 6-2](#)).

References

References are 16-bit words containing a sign bit and a 15-bit integer. A negative reference (indicating reversed direction of rotation) is formed by calculating the two's complement from the corresponding positive reference.

ABB drives can receive control information from multiple sources including analogue and digital inputs, the drive control panel and a communication module (e.g. NPBA-12). In order to have the drive controlled through PROFIBUS, the communication module must be defined as the source for control information, e.g. Reference. The scaling of the integer received from the master as Reference is drive-specific. See its Programming Manual for available control source selections and Reference scaling factors.

Actual Values

Actual Values are 16-bit words containing information on the operation of the drive. The functions to be monitored are selected with a drive parameter. The scaling of the integers sent to the master as Actual Values depends on the selected function. Please refer to the drive documentation.

Table 6-1 The Control Word (PROFIBUS Parameter 967). The upper case boldface text refers to the states shown in Figure 6-2.

Bit	Name	Value	Proceed to STATE/Description
0	ON	1	Proceed to READY TO OPERATE
	OFF1	0	Emergency OFF, stop by the selected deceleration ramp. Proceed to OFF1 ACTIVE ; proceed further to READY TO SWITCH ON unless other interlocks (OFF2, OFF3) are active
1	OFF2	1	Continue operation (OFF2 inactive)
		0	Emergency OFF, coast to stop. Proceed to OFF2 ACTIVE ; proceed further to SWITCH-ON INHIBITED
2	OFF3	1	Continue operation (OFF3 inactive)
		0	Emergency stop, stop according to fastest possible deceleration mode. Proceed to OFF3 ACTIVE ; proceed further to SWITCH-ON INHIBITED . Warning: Ensure motor and driven machine can be stopped using this stop mode.
3	RUN	1	Proceed to OPERATION ENABLED
		0	Inhibit operation. Proceed to OPERATION INHIBITED
4	RAMP_OUT_ZERO	1	Normal operation. Proceed to RAMP FUNCTION GENERATOR: OUTPUT ENABLED
		0	Stop according to selected stop type
5	RAMP_HOLD	1	Normal operation. Proceed to RAMP FUNCTION GENERATOR: ACCELERATOR ENABLED
		0	Halt ramping (Ramp Function Generator output held)
6	RAMP_IN_ZERO	1	Normal operation. Proceed to OPERATING
		0	Force Ramp Function Generator input to zero
7	RESET	0 ⇒ 1	Fault reset if an active fault exists. Proceed to SWITCH-ON INHIBITED
		0	(Continue normal operation)
8	INCHING_1		Inching 1. (See the drive documentation for information)
9	INCHING_2		Inching 2. (See the drive documentation for information)
10	REMOTE_CMD	1	Fieldbus (DDCS) control enabled
		0	Control Word <> 0 or Reference <> 0: Retain last Control Word and Reference Control Word = 0 and Reference = 0: Fieldbus (DDCS) control enabled
11 to 15			Drive-specific. (See the drive documentation for information)

Chapter 6 – Communication

Table 6-2 The Status Word (PROFIBUS Parameter 968). The upper case boldface text refers to the states shown in Figure 6-2.

Bit	Name	Value	STATE/Description
0	RDY_ON	1	READY TO SWITCH ON
		0	NOT READY TO SWITCH ON
1	RDY_RUN	1	READY TO OPERATE
		0	OFF1 ACTIVE
2	RDY_REF	1	OPERATION ENABLED
		0	
3	TRIPPED	1	FAULT
		0	No fault
4	OFF_2_STA	1	OFF2 inactive
		0	OFF2 ACTIVE
5	OFF_3_STA	1	OFF3 inactive
		0	OFF3 ACTIVE
6	SWC_ON_INHIB	1	SWITCH-ON INHIBITED
		0	
7	ALARM	1	Warning/Alarm
		0	No Warning/Alarm
8	AT_SETPOINT	1	OPERATING. Actual value equals reference value (= is within tolerance limits)
		0	Actual value differs from reference value (= is outside tolerance limits)
9	REMOTE	1	Drive control location: REMOTE
		0	Drive control location: LOCAL
10	ABOVE_LIMIT	1	Actual frequency or speed value equals or is greater than supervision limit
		0	Actual frequency or speed value is within supervision limit
11 to 14			Drive-specific
15		1	Error in DDCS communication (between fieldbus adapter module and drive). Adapter ceases to communicate with the master
		0	DDCS communication OK

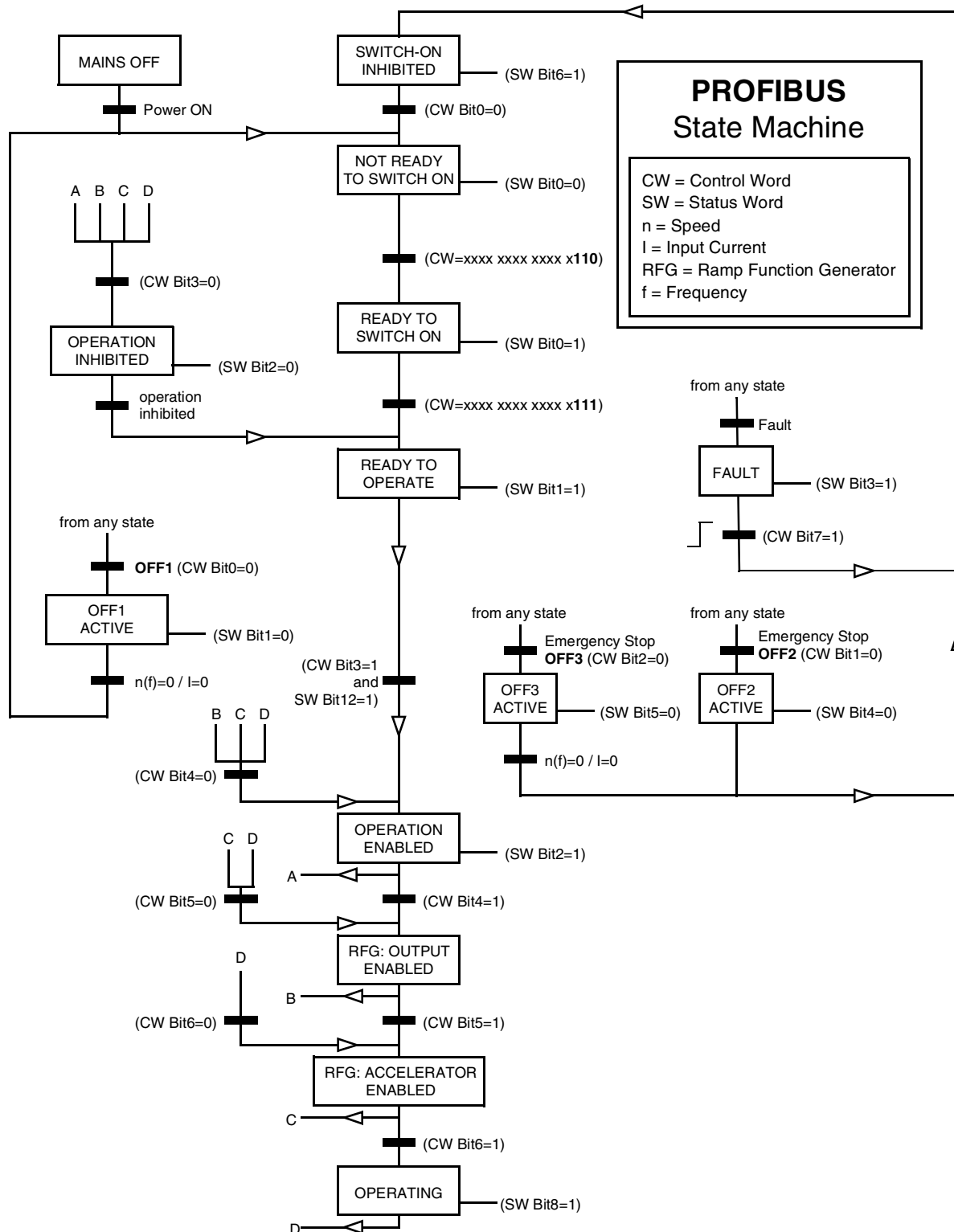
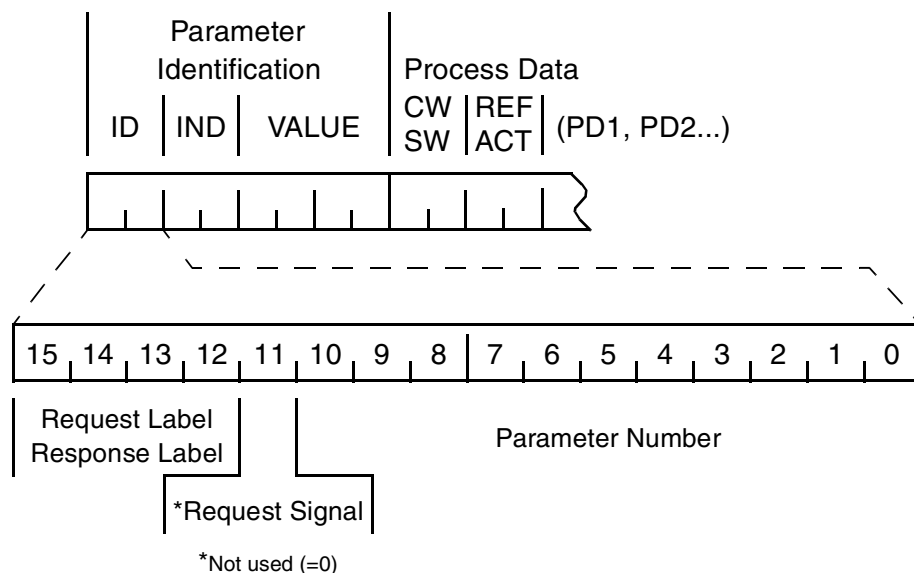

Figure 6-2 The PROFIBUS State Machine.

Chapter 6 – Communication

Parameters in Cyclic Communication (DP)

In cyclic PROFIBUS-DP communication, parameter data is transferred in PPO message types 1, 2 and 5 (see Figure 6-1). The Parameter Identification part consists of eight bytes (see below).



The Request Label is used by the master when transmitting data to the slave, while the Response Label is used by the slave as a positive or negative acknowledgement. The tables below show the Request/Response functions.

Request Labels (from Master to Slave)			
Request	Function	Response Labels	
		Ackn. (+)	Ackn. (-)
0	No task	0	–
1	Request parameter value	1, 2	7
2	Change parameter value (word)	1	7, 8
3	Change parameter value (double word)	2	7, 8
*4	Request description element	3	7
*5	Change description element	3	7, 8
*6	Request parameter value (array)	4, 5	7, 8
*7	Change parameter value (array word)	4	7, 8
*8	Change parameter value (array double word)	5	7,8
*9	Request number of array elements	6	7

*Not supported by NPBA-12 SW version V1.0

Response Label (Acknowledgement from Slave to Master)	
Ackn.	Function
0	No response
1	Transfer parameter value (word)
2	Transfer parameter value (double word)
3	Transfer description element
4	Transfer parameter value (array word)
5	Transfer parameter value (array double word)
6	Transfer number of array elements
7	Task cannot be executed, followed by error number 0 = Illegal PNU 1 = Parameter value cannot be changed 2 = Lower or upper limit violated 3 = Erroneous sub-index 4 = No array 5 = Incorrect data type 6 = Setting not allowed (can only be reset) 7 = Descriptive element cannot be changed 8 = PPO write, requested in the IR, not available 9 = Descriptive data not available 10 = Access group incorrect 11 = No parameter change rights 12 = Password incorrect 13 = Text cannot be read in cyclic data transmission 14 = Name cannot be read in cyclic data transmission 15 = Text array not available 16 = PPO write missing 17 = Task cannot be executed due to operating status 18 = Other error 19 = Data cannot be read in cyclic data transfer 103 = Request not supported 301 = Internal communication (DDCS) fault
8	No parameter change rights for PKW interface
9	Parameter data signal (word)
10	Parameter data signal (double word)

Chapter 6 – Communication

Example: Write In this example, current parameter settings are saved to the FLASH memory of the drive. This is done by setting the value of PROFIBUS Parameter No. 971 (3CBh) to 1.

Note that the drive always observes the Control Word (CW) and Reference (REF) bytes. The values shown below are examples.

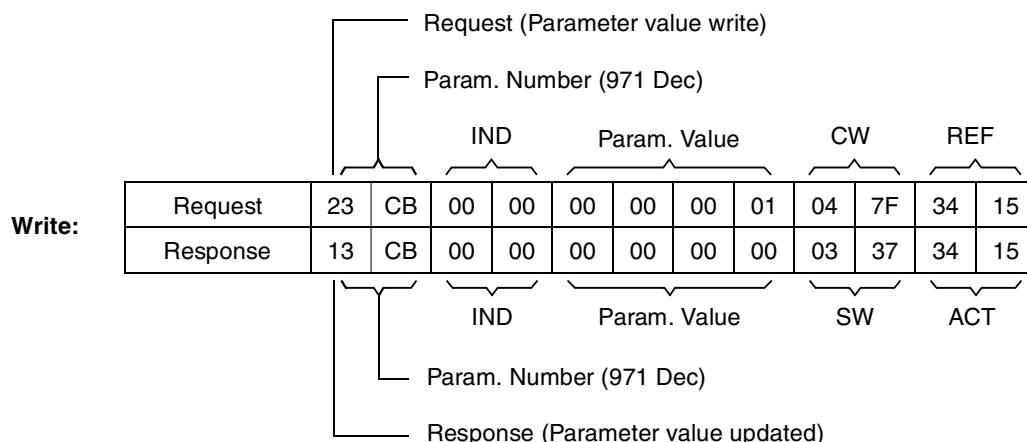

Example: Read In this example, PROFIBUS Parameter No. 918 is used to read the station number of the slave.

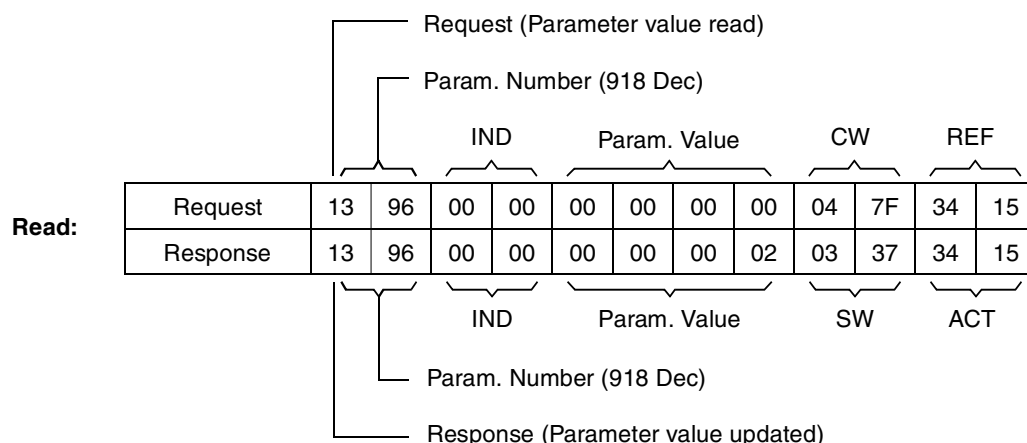

The slave returns its station number (2).

Parameters in Acyclic Communication (DPV1)

At the time of publishing, acyclic communication is not implemented in the NPBA-12.

Chapter 7 – Fault Tracing

Status LED Indications The tables below describe the Status LED indications during both the start-up sequence and operation.

Table 7-1 LED indications during the NPBA-12 start-up sequence.

Start-up Stage	Status LED Indications		
	<i>MASTER</i>	<i>MSG</i>	<i>DDCS</i>
Power-on	OFF	OFF	GREEN then RED then OFF
	OFF	GREEN then RED then OFF	OFF
	GREEN then RED then OFF	OFF	OFF
DDCS link initialisation	OFF	OFF	FLASHING GREEN (in progress) then GREEN
Transfer rate detection	FLASHING GREEN (in progress) then GREEN	OFF	GREEN
PROFIBUS communication establishment	GREEN	FLASHING GREEN (in progress) then GREEN	GREEN
Operation	GREEN	GREEN	GREEN

Chapter 7 – Fault Tracing

Table 7-2 Error indications.

Status LED Indications			Cause	Remedy
<i>MASTER</i>	<i>MSG</i>	<i>DDCS</i>		
RED	RED	OFF	RAM test failure	<ul style="list-style-type: none"> – Try resetting module. – Contact ABB service representative.
OFF	RED	RED	ROM test failure	
(Last valid state)	(Last valid state)	RED	*DDCS link failure	<ul style="list-style-type: none"> – Check that drive is powered. – Check fibre optic cables visually for dirt or flaws. – Ensure connectors are properly inserted. – Try new cables. – Contact ABB service representative.
GREEN	FLASHING RED	FLASHING GREEN	PROFIBUS communication failure (no data exchange)	<ul style="list-style-type: none"> – Check state of PROFIBUS master.
FLASHING RED	RED	FLASHING GREEN	PROFIBUS link failure	<ul style="list-style-type: none"> – Check state of PROFIBUS master. – Check PROFIBUS cable wiring (see Chapter 4).

*All errors that occur on the DDCS link between the NPBA-12 and the drive are reported to the PROFIBUS master (bit 15 of the Status Word is turned on).

Appendix A – PROFIBUS Parameters

The table below shows the PROFIBUS Profile-specific Parameters. All these values are of the “unsigned16” data type.

PROFIBUS Par. No.	Parameter Name	R/W	Description
918	NODE ADDRESS	R	Node address of the device Allowable values: 2, ..., 126
947	FAULT NUMBER	R	The last fault occurred in the drive 0h = No fault 1000h = Generic fault
963	CURRENT BAUD RATE	R	Detected baud rate 0 = 12 Mbit/s 1 = 6 Mbit/s 2 = 3 Mbit/s 3 = 1.5 Mbit/s 4 = 500 kbit/s 5 = 187.5 kbit/s 6 = 93.75 kbit/s 7 = 45.45 kbit/s 8 = 19.2 kbit/s 9 = 9.6 kbit/s 255 = Invalid baud rate
964	DEVICE IDENTIFICATION	R	Identification number of this device (6012h)
965	PROFILE NUMBER	R	Profile number of this device (0302h)
967	CONTROL WORD	R	16-bit word for controlling the drive
968	STATUS WORD	R	16-bit word indicating drive status
971	STORE	R/W	0 = No action 1 = Save drive parameters to non-volatile memory

Appendix A – PROFIBUS Parameters

Appendix B – Definitions and Abbreviations

PROFIBUS Definitions

Acyclic Communication	Communication in which messages are sent only once on request
Array	Parameter consisting of data fields of equal data type
Broadcast	Non-acknowledged message from master to all bus participants (compare Multicast)
Command Word	See Control Word
Communication Object	Any object of a real device that can be communicated with (variable, program, data range, etc.). Stored locally in the Object Dictionary
Control Word	16-bit word from master to slave with bit-coded control signals. (Sometimes called the Command Word)
Cyclic Communication	Communication in which Parameter-/Process Data-Objects are sent cyclically at pre-defined intervals
Device Class	Classification according to the number of profile functions included in the device
Drivecast	Broad- and Multicast, a special message frame for drives
Fault	Event that leads to tripping of the device
GSD File	ASCII-format device description file in a specified form. Each device (active & passive stations) on PROFIBUS has to have its own GSD File. GSD Files for various master stations are available from your local ABB representative.
Index	Access reference for Objects in PROFIBUS
Information Report	Non-acknowledged message from master to one or all groups of bus participants
Master	Control system with bus initiative. In PROFIBUS terminology, master stations are also called active stations
Multicast	Non-acknowledged message from master to one group of bus participants (compare Broadcast)
Name	Symbolic name of a parameter
Nibble	Set of 4 bits
Object Dictionary	Local storage of all Communication Objects recognised by a device
Object List	List of all accessible objects
Parameter	Value that can be accessed as Object, e.g. variable, constant, signal

Appendix B – Definitions and Abbreviations

Parameter Description	Specification of a parameter
Parameter Number	Parameter address
Parameter/Process Data Object	Special object that contains Parameter and Process Data
Process Data	Data that contains Control Word and Reference value or Status Word and Actual value. May also contain other (user-definable) control information
Profile	Adaptation of the protocol for certain application field, e.g. drives
Request Label	Coded information specifying the required service for the parameter part sent from master to slave
Response Label	Coded information specifying the required service for the parameter part sent from slave to master
Slave	Passive bus participant. In PROFIBUS terminology, slave stations (or slaves) are also called passive stations
Status Word	16-bit word from slave to master with bit-coded status messages
Warning	Signal caused by an existing alarm which does not lead to tripping of the device

PROFIBUS Abbreviations

The text in *italics* is the original German term.

.con	Confirmation
.ind	Indication
.req	Request
.res	Response
ACT	Actual Value <i>Istwert</i>
AK	Request Label/Response Label <i>Auftragskennung/Antwortkennung</i>
ALI	Application Layer Interface
CR	Communication Reference <i>Kommunikationsreferenz (Kommunikationsbeziehung)</i>
DP	Decentralised Periphery <i>Dezentrale Peripherie</i>
DP-ALI	Application Layer Interface for DP
DPV1	PROFIBUS-DP Extensions to the EN 50170 standard, including e.g. acyclic data exchange
FDL	Fieldbus Data Link
FMS	Fieldbus Message Specification
FSU	Manufacturer Specific Interface <i>Firmenspezifischer Umsetzer</i>
HIW	Main Actual Value <i>Hauptistwert</i>
HSW	Main Reference <i>Hauptsollwert</i>
ISW	see ACT
KR (KB)	see CR
PA	Process Automation <i>Prozessautomatisierung</i>
PD	Process Data <i>Prozessdaten</i>
PKE	Parameter Identification <i>Parameter-Kennung</i>
PKW	Parameter Identification Value <i>Parameter-Kennung-Wert</i>

Appendix B – Definitions and Abbreviations

PNU	Parameter Number <i>Parameter Nummer</i>
PPO	Parameter/Process Data Object <i>Parameter-/Prozessdaten-Objekt</i>
PWE	Parameter Value <i>Parameter-Wert</i>
PZD	see PD
PZDO	Process Data Object <i>Prozessdatenobjekt</i>
SAP	Service Access Point
SOW	Reference <i>Sollwert</i>
SPM	Request Signal <i>Spontanmeldung</i>
STW	Control Word <i>Steuerwort</i>
ZSW	Status Word <i>Zustandswort</i>

Appendix C – Technical Data

DDCS Link

Compatible Devices: All ABB Fieldbus Adapter modules; ACS 400, ACS/ACP/ACF 600, ACS 1000, DCS 400, DCS 500 Drives

Size of the Link: 2 stations

Medium: Fibre optic cable

- Construction: Plastic core, diameter 1 mm, sheathed with plastic jacket
- Attenuation: 0.31 dB/m
- Maximum Length between Stations: 10 m
- Specifications:

Parameter	Minimum	Maximum	Unit
Storage Temperature	-55	+85	°C
Installation Temperature	-20	+70	°C
Short Term Tensile Force		50	N
Short Term Bend Radius	25		mm
Long Term Bend Radius	35		mm
Long Term Tensile Load		1	N
Flexing		1000	cycles

Topology: Point-to-point

Serial Communication Type: Asynchronous, half Duplex

Transfer Rate: 4 Mbit/s

Protocol: Distributed Drives Communication System (DDCS)

Connectors: Blue – receiver; grey – transmitter

Appendix C – Technical Data

Fieldbus Link

Compatible Devices: All devices compatible with the PROFIBUS-DP and PROFIBUS-DPV1 protocols

Size of the Link: 127 stations including repeaters (31 stations and 1 repeater per segment)

Medium: Shielded, twisted pair RS485 cable

- Termination: built in the NPBA-12 Module
- Specifications:

Parameter	Line A PROFIBUS-DP	Line B DIN 19245 Part 1	Unit
Impedance	135 to 165 (3 to 20 MHz)	100 to 130 (f > 100 kHz)	Ω
Capacitance	< 30	< 60	pF/m
Resistance	< 110	–	Ω /km
Wire gauge	> 0.64	> 0.53	mm
Conductor area	> 0.34	> 0.22	mm ²

- Maximum Bus Length (m):

	Transfer Rate (kbit/s)						
	≤ 93.75	187.5	500	1500	3000	6000	12000
Line A	1200	1000	400	200	100	100	100
Line B	1200	600	200	–	–	–	–

Topology: Multi-drop

Serial Communication Type: Asynchronous, half Duplex

Transfer Rate: 9.6, 19.2, 44.45, 93.75, 187.5, 500, 1500, 3000, 6000, or 12000 kbit/s

Protocol: PROFIBUS-DP, PROFIBUS-DPV1

NPBA-12

Enclosure: Plastic, dimensions 100 × 22.5 × 115 mm (H×W×D); degree of protection IP 20

Mounting: Onto a standard mounting rail

Settings: Via drive interface (control panel)

Current Consumption: 70 mA at 24 V d.c.

Connectors:

- Light transmitter (grey) and receiver (blue) (Hewlett-Packard Versatile Link) for connection to the drive
- Two Combicon MSTBT 2,5/4-ST (4-pole, cross-section 2.5 mm² max.) screw terminal blocks for the fieldbus and power supply connections:

X1		Description
1	A	Data Negative (Conductor 2 in twisted pair).
2	B	Data Positive (Conductor 1 in twisted pair).
3	A	Data Negative (Conductor 2 in twisted pair).
4	B	Data Positive (Conductor 1 in twisted pair).

X2		Description
5	+24V	Power supply for the module (24 V d.c. ±10%).
6	0V	The power can be taken from the drive's internal power supply (see drive manuals), or an external power supply. On-board power supply shuts off if the voltage drops below 11 V.
7	DG	PROFIBUS cable data ground (optional 3rd conductor). Connected to module earth via a 1 MΩ/15 nF RC network.
8	SH	PROFIBUS cable shield. Internally connected to module earth.

General:

- All materials are UL/CSA approved
- Complies with EMC Standards EN 50081-2 and EN 50082-2

Appendix C – Technical Data

Appendix D – Ambient Conditions

Ambient Conditions, Operation

Ambient operating conditions refer to the conditions the option module is subjected to when installed for stationary use.

Air Temperature: 0 to +50 °C

Relative Humidity: 5 to 95%, no condensation allowed. Maximum allowed relative humidity is 60% in the presence of corrosive gases.

Contamination Levels:

Chemical gases: IEC 721-3-3, Class 3C2

Solid particles: IEC 721-3-3, Class 3S2

Installation Site Altitude: 0 to 2000 m. If the installation site is above 2000 m, contact local ABB representative.

Vibration: Max 0.3 mm (2 to 9 Hz), max 1 m/s² (9 to 200 Hz) sinusoidal (IEC 68-2-6)

Shock: Max 70 m/s², 22 ms (IEC 68-2-27)

Ambient Conditions, Storage

Ambient storage conditions refer to the conditions the option module is subjected to during storage in the protective package.

Temperature: -40 to +70 °C.

Relative Humidity: Less than 95%, no condensation allowed

Atmospheric Pressure: 70 to 106 kPa

Vibration: Max 0.3 mm (2 to 9 Hz), max 1 m/s² (9 to 200 Hz) sinusoidal (IEC 68-2-6)

Shock: Max 100 m/s², 11 ms (IEC 68-2-27)

Ambient Conditions, Transportation

Ambient transportation conditions refer to the conditions the option module is subjected to during transportation in the protective package.

Temperature: -40 to +70 °C

Relative Humidity: Less than 95%, no condensation allowed.

Atmospheric Pressure: 60 to 106 kPa

Vibration: Max 3.5 mm (2 to 9 Hz), max 15 m/s² (9 to 200 Hz) sinusoidal (IEC 68-2-6)

Shock: Max 100 m/s², 11 ms (IEC 68-2-27)

Bump: Max 300 m/s², 6 ms (IEC 68-2-29)

Free Fall: 250 mm

Appendix D – Ambient Conditions



NPBA-12/EN
3BFE 64341 588 R0125 REV A
EFFECTIVE: 01.01.2001

ABB Industry Oy

Drives
P.O.Box 184
FIN-00381 Helsinki
FINLAND
Telephone: +358 10 222 000
Fax: +358 10 222 2681
Internet: www.abb.com/automation

ABB Automation Inc.

Drives
16250 West Glendale Drive
New Berlin, WI 53151
USA
Telephone: 262 785-3416
800 243-4384
Fax: 262 785-8525