

PC10 Basic wiring diagram

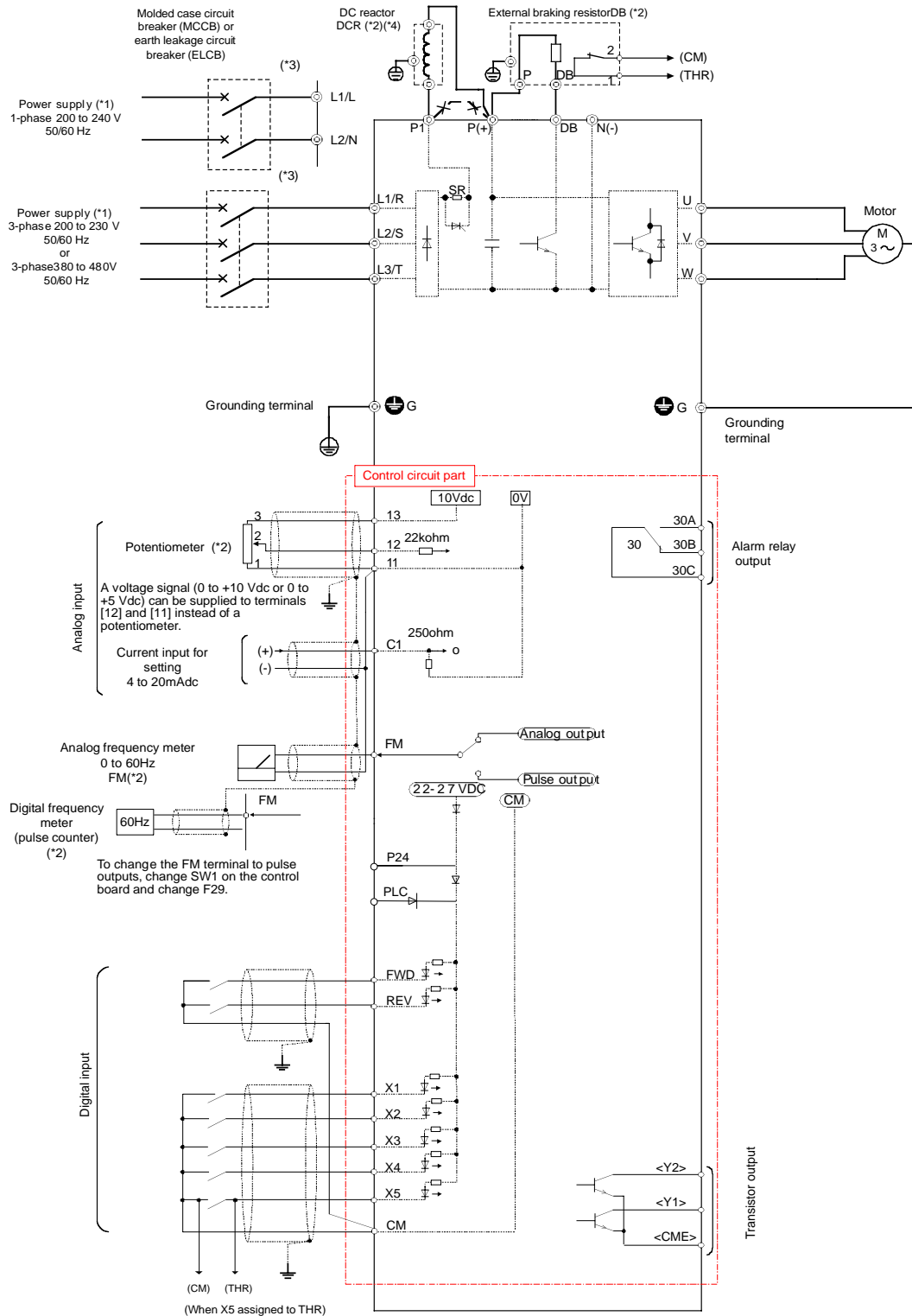

- *1) Source voltage must be suitable for the rated voltage of the drive.
- *2) Optional part. Use when necessary.
- *3) Peripheral equipment. Use when necessary.
- *4) To connect a DC reactor (DCR) for power factor correcting, remove the jumper between the P1 and P (+) terminals.