

Basic Connection Diagram (Sink Logic: Mainly American)

GP10 20HP (VT) 15HP (CT) and above

Up to 15HP (VT) 10HP (CT)

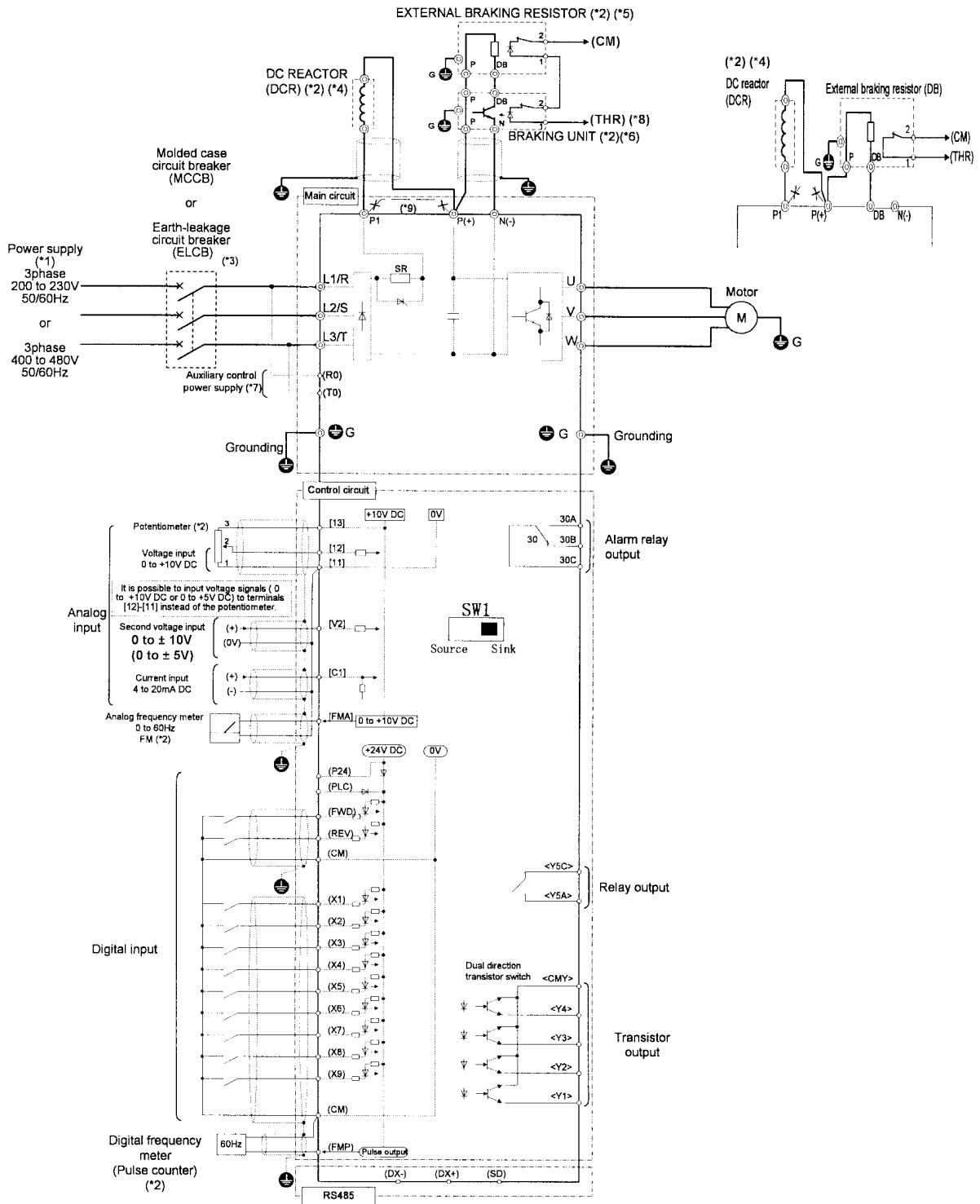

Note: The control circuit common terminals [1 1], (CM) and <CME> are isolated

(*1) Use a drive with rated voltage matching the power supply voltage.

(*2) Option. Use as required.

(*3) Use this peripheral device when necessary.

(*4) Remove the jumper wire (*9) between P1 and P(+) before connecting a DC REACTOR.

(*5) Be sure to use the braking unit (option)(*6) when connecting the external braking resistor (option)(*5)

(*6) Connect the braking unit to P(+) and N(-). The auxiliary terminals [1] and [2] have polarity. Connect them as shown in the diagram above.

(*7) The drive can be operated without connecting the auxiliary control power supply.

(*8) Terminal (X1) to (X9) can be preset (THR) (E01 to E09: 9).