

ABB Drives

Installation and Start-up Guide

DeviceNet Adapter Module
NDNA-02



DeviceNet Adapter Module
NDNA-02

**Installation and
Start-up Guide**

3AFY 58919829 R0325 REV B
EFFECTIVE: 1.10.2001

Safety Instructions

Overview

This chapter states the safety instructions that must be followed when installing and operating the NDNA-02 DeviceNet Adapter Module. The material in this chapter must be studied before attempting any work on, or with, the unit.

Warnings and Notes

This manual distinguishes two sorts of safety instructions. Warnings are used to inform of conditions which can, if proper steps are not taken, lead to a serious fault condition, physical injury and death. Notes are used when the reader is required to pay special attention or when there is additional information available on the subject. Notes are less crucial than Warnings, but should not be disregarded.

Warnings Readers are informed of situations that can result in serious physical injury and/or serious damage to equipment with the following symbols:



Dangerous Voltage Warning: warns of situations in which a high voltage can cause physical injury and/or damage equipment. The text next to this symbol describes ways to avoid the danger.



General Warning: warns of situations which can cause physical injury and/or damage equipment by means other than electrical. The text next to this symbol describes ways to avoid the danger.



Electrostatic Discharge Warning: warns of situations in which an electrostatic discharge can damage equipment. The text next to this symbol describes ways to avoid the danger.

Notes Readers are notified of the need for special attention or additional information available on the subject with the following symbols:

CAUTION!

Caution aims to draw special attention to a particular issue.

Note:

Note gives additional information or points out more information available on the subject.

Safety Instructions

General Safety Instructions



WARNING! All electrical installation and maintenance work on the drive should be carried out by qualified electricians.

The drive and adjoining equipment must be properly earthed.

Do not attempt any work on a powered drive. After switching off the mains, always allow the intermediate circuit capacitors 5 minutes to discharge before working on the frequency converter, the motor or the motor cable. It is good practice to check (with a voltage indicating instrument) that the drive is in fact discharged before beginning work.

The motor cable terminals of the drive are at a dangerously high voltage when mains power is applied, regardless of motor operation.

There can be dangerous voltages inside the drive from external control circuits even when the drive mains power is shut off. Exercise appropriate care when working with the unit. Neglecting these instructions can cause physical injury and death.



WARNING! There are several automatic reset functions in the drive. If selected, they reset the unit and resume operation after a fault. These functions should not be selected if other equipment is not compatible with this kind of operation, or dangerous situations can be caused by such action.

More Warnings and Notes are printed at appropriate instances along the text.

Table of Contents

Safety Instructions

Overview	iii
Warnings and Notes	iii
General Safety Instructions	iv

Table of Contents

Chapter 1 – Introduction to This Guide

Overview	1-1
Intended Audience	1-1
What This Guide Contains	1-1
Conventions Used in This Guide	1-2

Chapter 2 – Overview

Overview	2-1
DeviceNet Bus Topology	2-1
The NDNA-02 DeviceNet Adapter Module	2-2
Compatibility	2-3
Delivery Check	2-3
Warranty and Liability Information	2-3

Chapter 3 – Mechanical Installation

Overview	3-1
Mounting Outside the Drive	3-1
Mounting Inside the Drive	3-2

Chapter 4 – Electrical Installation

Overview	4-1
General Cabling Instructions	4-1
Earthing the Module	4-1
DIP Switch Settings	4-2
NDNA-02 Connections	4-5
Drive Connection	4-5
DeviceNet Connection	4-6

*Table of Contents***Chapter 5 – Programming**

Overview	5-1
Configuring the System	5-1
DeviceNet Connection Configuration	5-1
Control Locations	5-1

Chapter 6 – Communication

Overview	6-1
Introduction to DeviceNet	6-1
Object Modelling and Functional Profiles	6-1
Assembly Object	6-1
Parameter Handling	6-6
EDS Files	6-6
Editing EDS Files	6-7

Chapter 7 – Fault Tracing

Overview	7-1
NDNA-02 Status Codes	7-1
Status LEDs	7-2
Installation Problems	7-3
Drive Setup	7-3
PLC Programming	7-3
Scanner Fault Indications	7-3

Appendix A – Technical Data

DDCS Link	A-1
Fieldbus Link	A-2
NDNA-02	A-3

Appendix B – Ambient Conditions

Ambient Conditions, Operation	B-1
Ambient Conditions, Storage	B-1
Ambient Conditions, Transportation	B-1

Appendix C – Statement of Compliance

Chapter 1 – Introduction to This Guide

Overview

This chapter contains a description of the *Installation and Start-up Guide* for the NDNA-02 DeviceNet Adapter Module.

Intended Audience

The Guide is intended for the people who are responsible for installing, commissioning and using a DeviceNet Adapter Module with an ABB drive. The reader is expected to have a basic knowledge of electrical fundamentals, electrical wiring practices, the drive, the use of the drive control panel, and the DeviceNet protocol.

What This Guide Contains

The installation and start-up of the NDNA-02 DeviceNet Adapter Module are introduced in this Guide.

It is assumed that the drive is installed and ready to operate before starting the installation of the adapter module. For more information on the installation and start-up procedures of the drive, please refer to its user documentation.

Safety Instructions are featured in the first few pages of this Guide. Safety Instructions describe the formats for various warnings and notations used within this Guide. This chapter also states the safety instructions which apply to the installation and operation of the NDNA-02 Module.

Chapter 1 – Introduction to This Guide contains a short description of the Guide.

Chapter 2 – Overview contains a short description of the DeviceNet protocol and the NDNA-02 DeviceNet Adapter Module, a delivery checklist, and information on the manufacturer's warranty.

Chapter 3 – Mechanical Installation contains placing and mounting instructions for the module.

Chapter 4 – Electrical Installation contains wiring, bus termination, DIP setting and earthing instructions.

Chapter 5 – Programming explains how to program the drive before the communication through the adapter module can be started.

Chapter 6 – Communication contains a description of the DeviceNet functionality supported by the NDNA-02. This chapter also explains how to configure the Scanner.

Chapter 7 – Fault Tracing describes how to fault diagnose the DeviceNet connection during installation, commissioning, and normal operation.

Chapter 1 – Introduction to This Guide

Appendix A contains Technical Data.

Appendix B contains a specification of the ambient conditions allowed during transportation, storage and use of the NDNA-02.

Appendix C contains a Statement of Compliance.

Conventions Used in This Guide

<i>Bit-Strobe Message</i>	The Bit-Strobe Command is an I/O Message that is transmitted by the Master. A Bit-Strobe Command Message has multi-cast capabilities. Multiple Slaves can receive and react to the same Bit-Strobe Command (multi-cast capabilities). The Bit-Strobe Response is an I/O Message that a Slave transmits back to the Master when the Bit-Strobe Command is received.
<i>Change of State/Cyclic Message</i>	The Change of State/Cyclic Message is transmitted by either the Master or the Slave. A Change of State/Cyclic Message is directed towards a single specific node (point-to-point). An Acknowledge Message may be returned in response to this message.
<i>Communication Module</i>	Communication Module is a name for a device (e.g. a fieldbus adapter) through which the drive is connected to an external serial communication network (e.g. a fieldbus). The communication with the communication module is activated with a drive parameter.
<i>Data Sets and Data Words</i>	Data sets are clusters of data sent through the DDCS link between the NDNA-02 Adapter Module and the drive. Each data set consists of three 16-bit words, ie. data words. The Control Word (sometimes called the Command Word) and the Status Word, References and Actual Values (see <i>Chapter 6</i>) are types of data words; the contents of some data words are user-definable. For information, see the drive documentation.
<i>EDS File</i>	The Electronic Data Sheet (EDS) file identifies the properties of the device to the DeviceNet Scanner. Each type of drive and application program requires its own EDS file.
<i>Input</i>	In the ODVA DeviceNet specification the word 'input' is used to describe data flow from a device into to the network. In this manual, however, the word 'input' is used to describe data flow to a device such as the NDNA-02.
<i>I/O Assembly Selection</i>	Smart networked devices (like the NDNA-02) can produce and/or consume more than one I/O value. Typically, they will produce and/or consume one or more I/O value, as well as status and diagnostic information. Each piece of data communicated by a device is represented by an attribute of one of the device's internal objects. Communicating multiple pieces of data (attributes) across a single I/O connection requires that the attributes be grouped or assembled together into a single block.

<i>MAC ID</i>	Every node on DeviceNet network has to have a unique identifier. This node number is called MAC ID on device net (Media Access Control ID).
<i>NDNA-02 DeviceNet Adapter Module</i>	The NDNA-02 Adapter Module is one of the optional fieldbus adapter modules available for ABB drives. The NDNA-02 is a device through which an ABB drive is connected to a DeviceNet serial communication bus.
<i>ODVA</i>	ODVA stands for Open DeviceNet Vendor Association. ODVA is an independent organisation that promotes interoperativity between different manufacturers DeviceNet products. ABB is an Associate Member at the ODVA.
<i>Output</i>	In the ODVA DeviceNet specification the word 'output' is used to describe data flow from the network into a device. In this manual, however, the word 'output' is used to describe data flow from a device such as the NDNA-02.
<i>Parameter</i>	A parameter is an operating instruction for the drive. Parameters can be read and programmed with the drive control panel, or through the NDNA-02 Module.
<i>Poll Message</i>	<p>Most of the DeviceNet Scanners and NDNA-02 V2.x support 3 different data services. These are Poll, Bit-Strobe and Change of State/Cyclic messages.</p> <p>The Poll Command is an I/O Message that is transmitted by the Master. A Poll Command is directed towards a single, specific Slave (point-to-point, NDNA-02 always acts as a Slave). A Master must transmit a separate Poll Command Message for each one of its Slaves that is to be polled. The Poll Response is an I/O Message that a Slave transmits back to the Master when the Poll Command is received.</p>
<i>Scanlist</i>	The DeviceNet Scanner communicates with the DeviceNet Slaves in a user-defined order. This order of communication is the scanlist. The scanlist contains a complete list of the Slave nodes, and the order in which the Slaves are accessed.

Chapter 1 – Introduction to This Guide

Chapter 2 – Overview

Overview

This chapter contains a short description of a DeviceNet bus topology, the NDNA-02 Adapter Module, a delivery checklist, and warranty information.

Further information can be obtained from www.odva.org.

DeviceNet Bus Topology

The DeviceNet network has a linear bus topology. Terminating resistors are required on each end of the trunk line. Drop lines as long as 6 metres (20 feet) each are permitted, allowing one or more nodes to be attached. DeviceNet allows branching structures only on drop lines. An example of an allowable topology is shown in Figure 2-1.

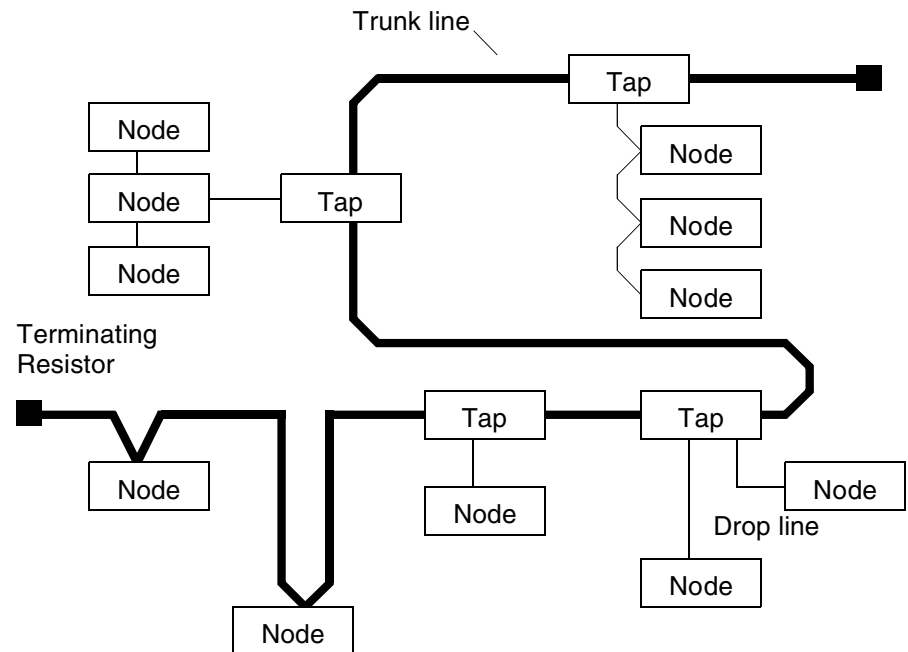

Figure 2-1 DeviceNet bus topology.

The maximum length of trunk cable depends on the data rate and on the type of the cable used (see Appendix A).

Terminating Resistor

The DeviceNet network should be terminated at both ends of the trunk cable with a 121 Ω , ¼ W, 1% Metal Film resistor. Connect this resistor between the two signal wires (CAN_H, CAN_L) on the DeviceNet cable.

The NDNA-02 DeviceNet Adapter Module

The NDNA-02 DeviceNet Adapter Module is an optional device for ABB drives which enables the connection of the drive to a DeviceNet system. The drive is considered as a slave in the DeviceNet network. Through the NDNA-02 DeviceNet Adapter Module it is possible to:

- Give control commands to the drive (Start, Stop, Run enable, etc.)
- Feed a motor speed or torque reference to the drive
- Give a process actual value or a process reference to the PID controller of the drive
- Read status information and actual values from the drive
- Read and write drive parameter values
- Reset a drive fault.

The NDNA-02 acts as a Class 2 slave only with predefined master-slave connection set services. These include the Explicit Messaging, the Poll-Response service, the Bit-Strobe service and the Change of State/Cyclic service. The DeviceNet commands and services supported by the NDNA-02 DeviceNet Adapter Module are discussed in Chapter 6. Please refer to the user documentation of the drive as to which commands are supported by the drive.

The adapter module is mounted onto a standard mounting rail inside or outside the drive unit, depending on drive type and configuration. See the user's manual of the drive for module placement options.

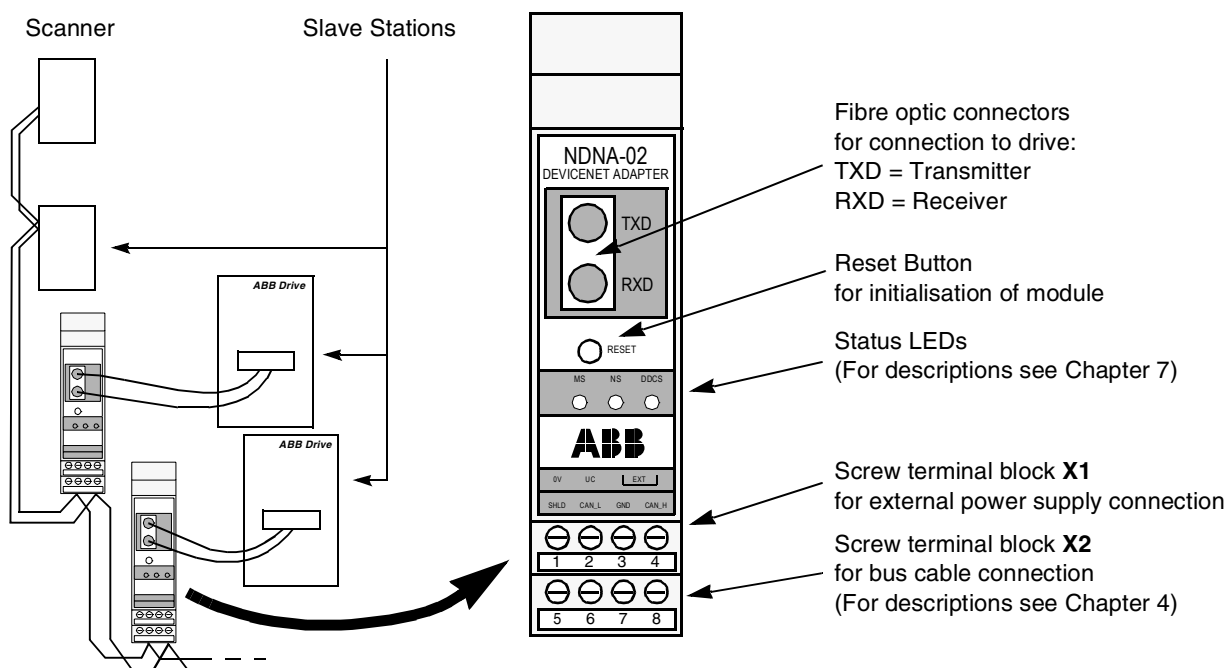

Figure 2-2 The construction of the DeviceNet link and the NDNA-02 Adapter Module.

- Compatibility** The NDNA-02 is compatible with:
- ACS 400
 - ACS 600 SingleDrive
 - ACS 600 MultiDrive
 - ACS 600 MotionControl (ACP 600)
 - ACS 600 CraneDrive (ACC 600)
 - ACS 600 Programmable
 - ACS 6000
 - DCS 500
 - DCS 600
 - ACS 1000
 - All scanners that work according to ODVA DeviceNet specifications. (The NDNA-02 has been tested with the Allen-Bradley 1747-SDN scanner module.)

- Delivery Check** The option package for the NDNA-02 DeviceNet Adapter Module contains:
- DeviceNet Adapter Module, Type NDNA-02
 - Two pairs (four pieces) of fibre optic cables for connecting the adapter to the drive
 - Mounting rail
 - This manual, the *NDNA-02 Installation and Start-up Guide*.

- Warranty and Liability Information** The warranty for your ABB drive and options covers manufacturing defects. The manufacturer carries no responsibility for damage due to transport or unpacking.
- In no event and under no circumstances shall the manufacturer be liable for damages and failures due to misuse, abuse, improper installation, or abnormal conditions of temperature, dust, or corrosives, or failures due to operation above rated capacities. Nor shall the manufacturer ever be liable for consequential and incidental damages.
- The period of manufacturer's warranty is 12 months, and not more than 18 months, from the date of delivery. Extended warranty may be available with certified start-up. Contact your local distributor for details.
- Your local ABB Drives company or distributor may have a different warranty period, which is specified in their sales terms, conditions, and warranty terms.
- If you have any questions concerning your ABB drive, contact your local distributor or ABB Drives office.
- The technical data and specifications are valid at the time of printing. ABB reserves the right to subsequent alterations.

Chapter 2 – Overview

Chapter 3 – Mechanical Installation

Overview

This chapter contains module mounting instructions. Depending on the drive, the module can be installed either inside or outside the drive housing or cabinet. See the user's manual of the drive for module placement options.

Mounting Outside the Drive

Choose the location for the module. Note the following:

- The cabling instructions in Chapter 4 must be followed.
- The ambient conditions should be taken into account (see Appendix B). The degree of protection of the module is IP 20.
- Observe the free space requirements for the module (see the figure below) and the drive (see the drive documentation).
- Module earth is connected to the mounting rail by means of an earthing clip (see the figure below). The mounting rail onto which the option module is to be mounted must be earthed to a noiseless earth. If the rail is not mounted on a properly earthed base, a separate earthing conductor must be used. The conductor must be as short as possible and its cross-sectional area must be 6 mm^2 at least. **Note:** No solid copper conductor may be used (stranded wire allowed only).

Mounting instructions:

1. Switch off all dangerous voltages in the enclosure that the module is to be mounted in.
2. Fasten the rail and ensure the proper earthing as described above.
3. Push the module onto the rail. The module can be released by pulling the locking spring with a screwdriver (see below).

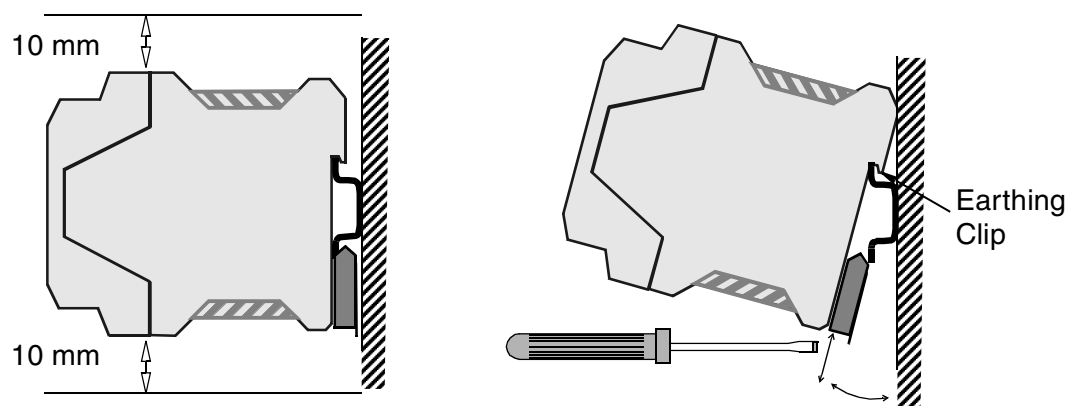

**Mounting Inside
the Drive**

The work inside the drive should be carried out by a qualified electrician only.



WARNING! Pay attention to the slowly discharging voltage of the capacitor bank and the voltages that are connected from external control circuits to the inputs and outputs of the drive.



WARNING! Do not touch the printed circuit boards. The integrated circuits are extremely sensitive to electrostatic discharge.

Mounting instructions:

1. Stop the drive.
2. Switch off the power supply of the drive and all dangerous voltages connected to the inputs and outputs.
3. Wait for five minutes to ensure that the capacitors in the intermediate circuit have discharged.
4. Remove the front cover of the drive.
5. Ensure that the mains cable, motor cable and capacitor bank (UDC+ and UDC–) are not powered.
6. Locate the position for the module (see the drive documentation). Fasten the mounting rail to its place if not already installed. Observe the free space requirements for the module (see the figure above).
7. Push the module onto the rail. The module can be released by pulling the locking spring with a screwdriver (see the figure above).

Chapter 4 – Electrical Installation

Overview

This chapter contains:

- general cabling instructions
- module earthing instructions
- instructions of setting the module node number and communication speed (baud rate)
- instructions for connecting the module to the drive and to the DeviceNet bus.



WARNING! Before installation, switch off the drive power supply. Wait five minutes to ensure that the capacitor bank of the drive is discharged. Switch off all dangerous voltages connected from external control circuits to the inputs and outputs of the drive.

General Cabling Instructions

Bus cables are specified in *Appendix A – Technical Data*.

Arrange the bus cables as far away from the motor cables as possible. Avoid parallel runs. Use bushings at cable entries.

Handle fibre optic cables with care. When unplugging optic cables, always grab the connector, not the cable itself. Do not touch the ends of the fibres with bare hands as the fibre is extremely sensitive to dirt.

The maximum long term tensile load for the fibre optic cables is 1 N. The minimum short term bend radius is 25 mm.

Earthing the Module

The NDNA-02 module earth is connected to the rail onto which the module is mounted. If the rail is fastened to an earthed metallic assembly plate, the module is automatically earthed, and no external earthing wire is needed. If the rail is fastened to a base that is not earthed, the rail must be connected to the nearest earthing terminal. However, the earthing wire should not be connected to the same terminal as the power cable screens. (See the mounting instructions in Chapter 3.)

DIP Switch Settings

The DIP switches SW1 and SW2 on the NDNA circuit board can be used to select the node number, Scanner Idle Mode, and baud rate for the module.

Setting switch SW1:8 to ON enables DIP switch selection. In this case, the corresponding configuration parameters (in the fieldbus parameter group; see Chapter 5) only act as read-only indicators. If SW1:8 is set to OFF (default), the node number and baud rate are selected through the module configuration parameters (see Chapter 5).

Setting switch SW2:3 to ON (NDNA-01) enables the NDNA-02 module to be used as replacement for NDNA-01 modules with software version V2.0. In this case the original NDNA-01 EDS file must be used.

Setting switch SW2:4 to ON (FREEZE) enables the drive to continue operation according to the last-received valid Control Word and References in case the DeviceNet Scanner is switched to Idle mode (eg. off-line). With SW2:4 in the OFF (STOP) position, the drive will stop when the Scanner is switched to Idle mode. For more information, refer to the drive manuals (communication loss fault functions).

Notes:

- The Scanner Idle Mode function is supported from version V2.2 onwards.
 - The Module Mode function is supported from version V2.3 onwards.
 - Switches SW2:3 and SW2:4 are always effective independent of SW1:8.
-

The figures below show how the DIP switches on the circuit board can be accessed.

- ① Press down the clips on top and bottom of the module.



Bottom View

- ② Pull the PCB outwards. (Stoppers prevent the PCB from being completely removed.)

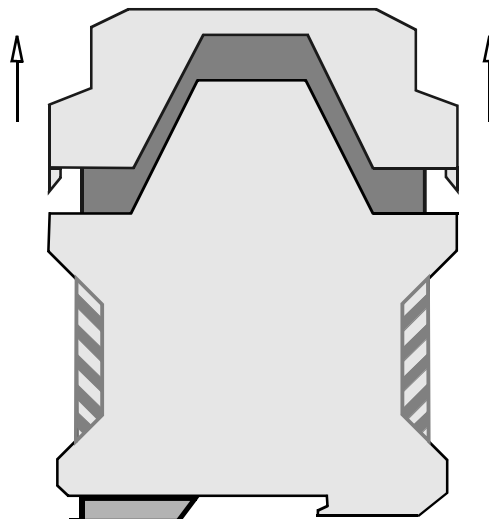

Side View

- ③ Make the required settings.

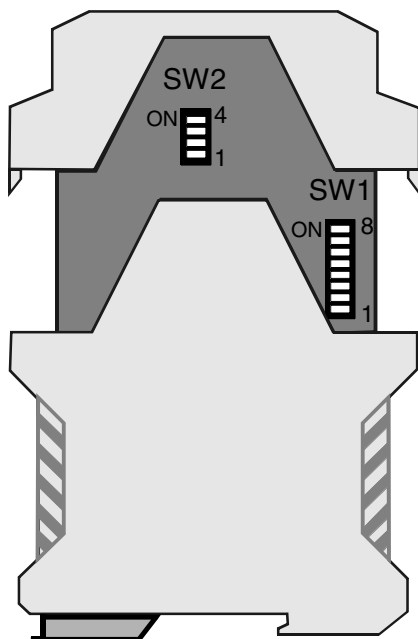

Chapter 4 – Electrical Installation

Function	SW1
SW1 and SW2 enabled – node no. and baud rate selected with DIP switches.	
*SW1 and SW2 disabled – node no. and baud rate selected with parameters. (Default)	

Node No.	Binary	SW1
1	000001	
2	000010	
...
63 (Default)	111111	

Baud Rate	Binary	SW2
125 kbit/s (Default)	xx00	
250 kbit/s	xx01	
500 kbit/s	xx10	

Module Mode	Binary	SW2
NDNA-02 (Default)	x0xx	
NDNA-01	x1xx	

Scanner Idle Mode	Binary	SW2
STOP (Default)	0xxx	
FREEZE	1xxx	

- ④ Finally, close the module by sliding the PCB back until the clips lock into their recesses.

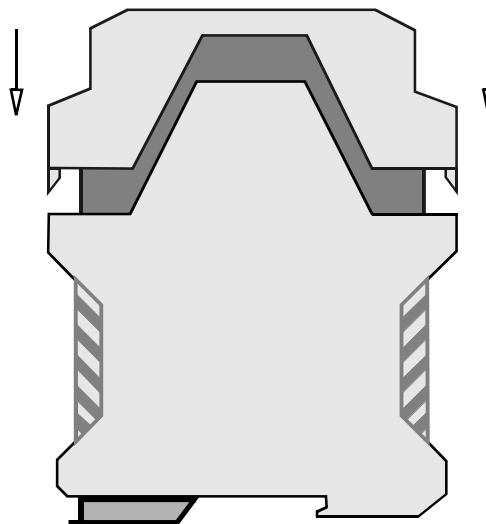

NDNA-02 Connections

Drive Connection

The NDNA-02 module is connected to the drive using a fibre optic cable link. Consult the drive documentation as to the corresponding terminals inside the drive.

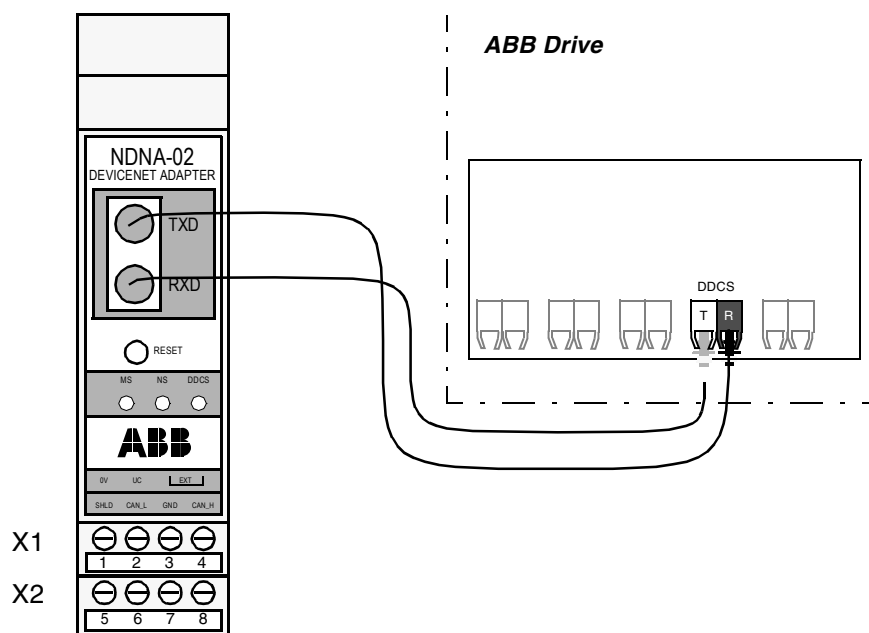

Figure 4-1 Fibre optic link connecting the NDNA-02 to the drive.

Chapter 4 – Electrical Installation

DeviceNet Connection The bus cable and the external power supply are connected to terminal blocks X1 and X2 on the NDNA-02.

The terminal blocks are described below.

X1		Description	
1	0 V	DC GND	Power supply ground (0 V). If the power to the module is supplied through the DeviceNet network, this terminal should be left unconnected.
2	UC	+24 VDC	+24 V ±10% (80 mA) d.c. supply to the module. The power can be taken from the drive's internal power supply (see drive manuals), a dedicated external power supply, or through the DeviceNet network. The on-board power supply is disabled if the voltage drops below 11 V.
3	EXT	DC GND	These terminals should be connected together if the power to the module is supplied through the DeviceNet network. This makes the NDNA-02 a non-isolated node.
4		CAN GND	
X2		Description	
5	SHLD	Network cable shield.	
6	CAN_L	CAN_L bus line.	
7	GND	DeviceNet bus ground (digital ground).	
8	CAN_H	CAN_H bus line.	

DeviceNet Bus Termination The DeviceNet bus line must be terminated with 121 ohm resistors connected between the CAN_L and CAN_H wires at each end as shown below.

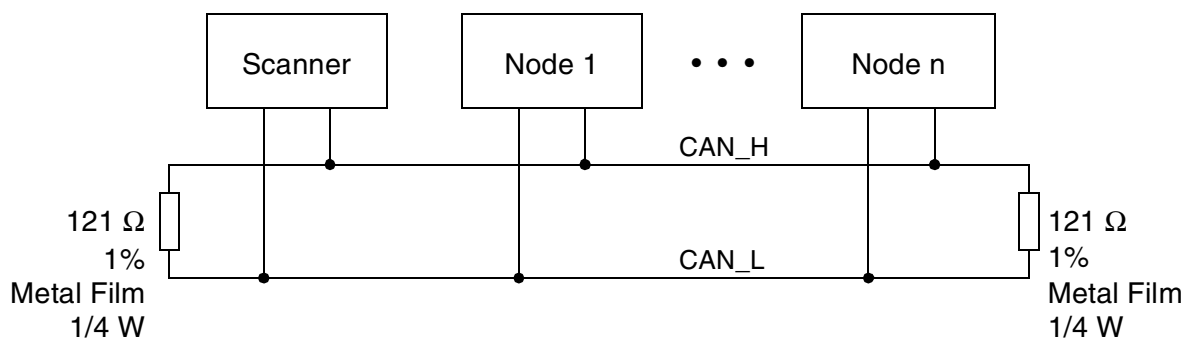

Connection Examples

Isolated Node Powered from a Dedicated Power Supply

5-pin Micro-style Connector

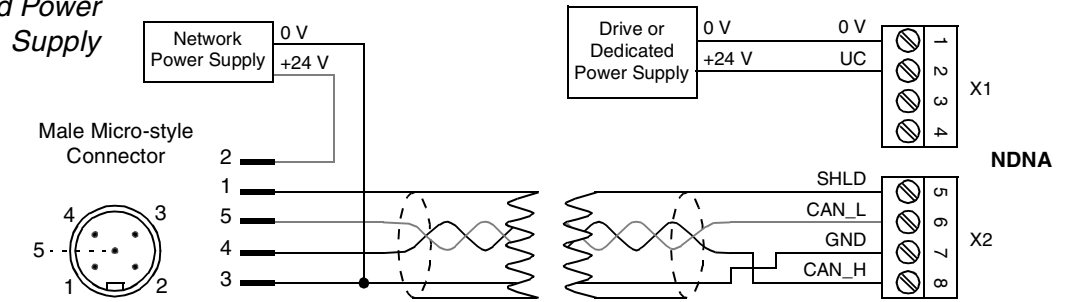

5-pin Mini-style Connector

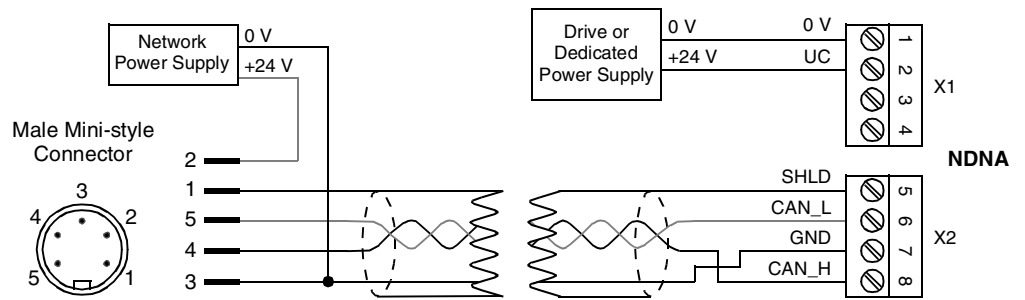

Standard Open-style Screw Connector

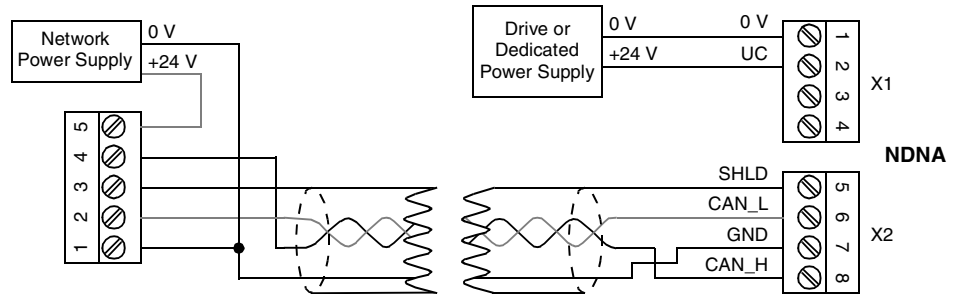

Non-isolated Node Powered from the Network

Standard Open-style Screw Connector

Note: Use this connection only if power supply is connected to CAN ground, and the CAN bus is short.

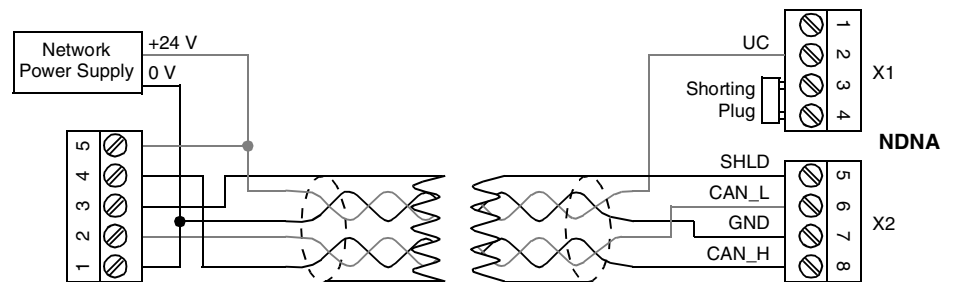

Chapter 4 – Electrical Installation

Chapter 5 – Programming

Overview	This chapter gives information on configuring the NDNA-02 DeviceNet Adapter Module.
Configuring the System	<p>After the NDNA-02 DeviceNet Adapter Module has been mechanically and electrically installed according to the instructions in Chapters 3 and 4, the drive must be prepared for communication with the module and Scanner.</p> <p>Please refer to the Scanner documentation for information on configuring the system for communication with the NDNA-02. Configuration (EDS) files for the NDNA-02 are available from your local ABB representative.</p>
DeviceNet Connection Configuration	<p>The detailed procedure of activating the module for communication with the drive is dependent on the drive type. (Normally, a parameter must be adjusted to activate the communication. See the drive documentation.)</p> <p>As communication between the drive and the NDNA-02 is established, several configuration parameters are copied to the drive. These parameters (shown in Table 5-1) must be checked first and adjusted if necessary. The alternative selections for these parameters are discussed in more detail below the table.</p> <hr/> <p>Note: The new settings take effect only when the module is powered up or the RESET button pressed for the next time.</p> <hr/> <p>Note: The grouping, numbering, and adjustment procedure of parameters vary from drive to drive. See the drive documentation for information.</p> <hr/>
Control Locations	ABB drives can receive control information from multiple sources including digital inputs, analogue inputs, the drive control panel and a communication module (e.g. NDNA-02). ABB drives allow the user to separately determine the source for each type of control information (Start, Stop, Direction, Reference, Fault Reset, etc.). In order to give the fieldbus Scanner the most complete control over the drive, the communication module must be selected as source for this information. See the user documentation of the drive for information on the selection parameters.

Chapter 5 – Programming

Table 5-1 The NDNA-02 configuration parameters.

Fieldbus Par. No.	Parameter Name	Alternative Settings	Default Setting
1	FIELD BUS	NDNA-02 V2.x	NDNA-02 V2.x
2*	MAC ID	0 ... 63	63
3*	BAUD RATE	(0) 125 kBit/s; (1) 250 kBit/s; (2) 500 kBit/s	(0) 125 kBit/s
4	STATUS	(0) SELF TEST; (1) NO CONNECT; (2) CONNECTED; (3) TIMEOUT; (4) DUP. MAC ERR; (5) BUS_OFF; (6) COM. ERROR; (7) WRONG ASMBLY	Read only (parameter). The module shows value NO CONNECT after first power-up.
5	PROFILE SELECTION	(0) ABB DRIVES; (1) CSA 2.8/3.0	(0) ABB DRIVES (1) CSA 2.8/3.0 (ACS 600 3.0 or before)
6	POLL OUTPUT SELECT	(0) BASIC SPEED; (1) TRANSPARENT; (2) PARAMETERS; (3) MUL. DATASETS	(0) BASIC SPEED
7	POLL/COS INPUT SEL		
8	COS DATA OUTPUT		
9	BIT STROBE OUTPUT		
10	DATASET INDEXES	(0) FBA DSET 1; (1) FBA DSET 10	(0) FBA DSET 1
11	SPEED REF. SCALE	0 ... 32767	1500
12	SPEED ACT. SCALE	0 ... 32767	1500
13	ABB DRIVES STOP M	(0) COAST STOP; (1) RAMP STOP	(0) COAST STOP
14	RAMP STOP LEVEL	0 ... 20000	1000
15	NO. OF DATASETS	1 ... 20	1

*If DIP switches are enabled (SW1:8 is ON), this parameter is read-only. See Chapter 4.

Note: The Default values are used when the module is connected to the drive for the first time. The parameters in the fieldbus group must be set up for the current application.

Note: Some of the assembly selections are not valid for all the drive types. If an incorrect assembly is selected, the module state parameter will show value WRONG ASMBLY after power-up. See next paragraph for correct selections.

- 01 MODULE TYPE** Shows the connected communication option module type and version.
- 02 MAC ID** Identifies the MAC ID for the node.
- 0 ... 63**
On a DeviceNet network, each node is identified by a unique node number. This node number is between 0 and 63, and is called MAC ID.
-
- Note:** If DIP switches are enabled (SW1:8 is ON), this parameter is read-only. See Chapter 4.
-
- Note:** Changing this value through the DeviceNet network will reset the module's DeviceNet communication.
-
- 03 BAUD RATE** Sets the baud rate for the DeviceNet interface. This is user selectable, but must be the same on every node on the DeviceNet network.
- 125 kBit/s; 250 kBit/s; 500 kBit/s**
-
- Note:** If DIP switches are enabled (SW1:8 is ON), this parameter is read-only. See Chapter 4.
-
- 04 STATUS** This Status parameter indicates the status of the DeviceNet module. See Chapter 7 for more detailed information.
- SELF TEST; NO CONNECT; CONNECTED; TIME-OUT; DUP. MAC ERR; BUS OFF; COM. ERROR; WRONG ASMBLY**
- 05 PROFILE SELECTION** Chooses the communication profile between the drive and the module. See the drive manual for correct setting.
- CSA 2.8/3.0**
should be selected for ACS 600 with Standard Application Program version CSA 2.8 or CSA 3.0.
- ABB DRIVES**
should be selected for other drive types.
- Assembly Selections* The following table describes the different I/O assembly selections supported by different drive types. Detailed information about the I/O data format of the different assemblies is given in Chapter 6.

Assembly selection	Supported by
BASIC SPEED	All the drive types except ACS 1000
TRANSPARENT	All the drive types
PARAMETERS	All the drive types except ACS 400 and ACS 600 3.0
MUL. DATASETS	All the drive types except ACS 400 and ACS 600 3.0

Chapter 5 – Programming

06 POLL OUTPUT SELECT This parameter chooses the I/O Assembly format for the data that is sent as a reply to Poll command.

BASIC SPEED; TRANSPARENT; PARAMETERS; MUL. DATASETS

07 POLL/COS INPUT SEL This parameter chooses the I/O Assembly format that is interpreted when receiving a Poll command or a COS/Cyclic message.

BASIC SPEED; TRANSPARENT; PARAMETERS; MUL. DATASETS

Note: In order that the drive can be controlled via the NDNA-02, either the Poll or COS/Cyclic connection has to be allocated with an input assembly that enables control (not PARAMETERS). If the COS/cyclic is selected, the heartbeat/sendrate of the scanner should be set to a minimum of 2500 ms to avoid timeout errors.

08 COS DATA OUTPUT This parameter chooses the I/O Assembly format for the data that is sent as a COS/Cyclic message.

BASIC SPEED; TRANSPARENT; PARAMETERS; MUL. DATASETS

09 BIT STROBE OUTPUT This parameter chooses the I/O Assembly format for the data that is sent as a reply to a bit-strobe message.

BASIC SPEED; TRANSPARENT; PARAMETERS

Note: The bit-strobe assembly does not include selections where the data size is larger than 8 bytes.

10 DATASET INDEXES Defines the offset for data set indexes (numbers). See the drive documentation for information.

FBA DSET 1 (no offset)

The first data set sent from the master to the drive (the Control Word) is Data Set 1 (DS1).

FBA DSET 10 (offset 9)

The first data set sent from the master to the drive (the Control Word) is Data Set 10 (DS10).

11 SPEED REF. SCALE Defines the scaling factor for the speed reference value.

0 ... 32767

In the ODVA Drive Profile, the speed reference unit and resolution is 1 rpm. The integer reference value (Reference 1 in the first input dataset) transmitted by the NDNA-02 to the drive is determined in the following way:

$$\text{Reference 1} = \frac{\text{DeviceNet speed reference} \times 20000}{\text{SPEED REF. SCALE}}$$

In order to have the drive's internal reference following the DeviceNet reference, SPEED REF. SCALE has to be set according to the speed scaling parameters of the drive.

Note: Only used together with the BASIC SPEED assembly.

Example 1: ACS 600 with Standard Application Program, DTC mode
Parameter 11.05 EXT REF 1 MAX (which corresponds to reference 1 value 20000) is set to 1250 rpm. The value for SPEED REF. SCALE can be derived in the following way:

$$20000 = \frac{1250 \text{ rpm} \times 20000}{\text{SPEED REF. SCALE}}$$

which means that the scaling must be 1250 in order for the DeviceNet rpm speed reference to correspond to the drive's internal rpm reference.

Example 2: ACS 600 with Standard Application Program, Scalar control mode

When an asynchronous motor runs at its nominal frequency without load, its speed should be approximately equal to its synchronous speed. Assume that the nominal frequency is 50 Hz and synchronous speed is 1500 rpm. Parameter 11.05 is set 25 Hz (maximum reference in rpm ~750 if slip is not considered). The value for SPEED REF. SCALE can be derived in the following way:

$$20000 = \frac{750 \text{ rpm} \times 20000}{\text{SPEED REF. SCALE}}$$

which means that the scaling must be 750 in order for the DeviceNet rpm speed reference to correspond to the drive's internal Hz reference as closely as possible.

Note: Other drives and application programs may have a different parameter for speed reference scaling.

12 SPEED ACT. SCALE Defines the scaling factor for speed actual value.

0 ... 32767

In the ODVA Drive Profile, the speed actual unit and resolution is 1 rpm. The integer speed or frequency actual value (speed or frequency selected to be Actual 1 value in first output dataset) received by the NDNA-02 from the drive is handled in the following way by the NDNA-02 module:

$$\text{DeviceNet speed actual} = \frac{\text{Actual 1} \times \text{SPEED ACT. SCALE}}{20000}$$

In order to have the DeviceNet speed actual value following the actual motor speed value, SPEED ACT. SCALE has to be set according to the speed scaling parameters in the drive.

Note: Only used together with the BASIC SPEED assembly.

Example 1: ACS 600 Standard Application Program, DTC mode
Parameter 20.01 MIN SPEED is set to -1000 rpm and 20.02 MAX SPEED is set to 1250 rpm. The Actual 1 value is selected to be speed (1.02). The value for SPEED ACT. SCALE can be derived in the following way:

$$1250 \text{ rpm} = \frac{\begin{array}{c} \text{(Actual 1 value with 1250 rpm)} \\ \downarrow \\ 20000 \times \text{speed act. scale} \end{array}}{20000}$$

which means that the scaling must be 1250 in order for the DeviceNet rpm actual speed value to correspond the motor speed.

Example 2: ACS 600 Standard Application Program, Scalar control mode

When an asynchronous motor runs at its nominal frequency without load, its speed should be approximately its synchronous speed. Assume that the nominal frequency is 50 Hz and synchronous speed is 1500 rpm. The Actual 1 value is selected to be frequency (1.03). The value for SPEED ACT. SCALE can be derived in the following way:

$$1500 \text{ rpm} = \frac{\begin{array}{c} \text{(50 Hz output frequency, scaling 1 Hz = 100)} \\ \downarrow \\ 5000 \times \text{speed act. scale} \end{array}}{20000}$$

which means that the scaling must be 6000 in order for the DeviceNet rpm actual speed value to correspond to the motor speed as closely as possible.

Note: Other drives and application programs may have a different parameter for speed actual scaling.

13 ABB DRIVES STOP M

This parameters defines the stop mode to be used with the BASIC SPEED I/O assembly. The corresponding drive parameters have no effect in fieldbus control if ABB Drives Communication Profile is used.

COAST STOP

If COAST STOP is selected, the drive coasts down when RunFwd is set to 0.

RAMP STOP

If RAMP STOP is selected, the drive ramps down when RunFwd is set to 0.

Note: Only used together with the BASIC SPEED assembly and the ABB DRIVES communication profile.

Upon a RAMP STOP, the NDNA-02 activates the RAMP_OUT_ZERO bit in the ABB Drives Profile Control Word and observes the Actual 1 value (speed or frequency must be selected). When the Actual 1 value goes below the value defined by Fieldbus Parameter 14 RAMP STOP LEVEL, the NDNA-02 coast-stops the motor.

14 RAMP STOP LEVEL

Defines the level where the RAMP_OUT_ZERO bit is released and coast stop is activated.

0 ... 20000

The value of RAMP STOP LEVEL corresponds to the Actual 1 value and its scaling.

Note: Only used together with the BASIC SPEED assembly and the ABB DRIVES communication profile.

For example, when frequency is selected as dataset 2 value 1 in the ACS 600 drive, value 250 in RAMP STOP LEVEL equals 2.5 Hz. Likewise, when speed is selected as dataset 2 value 1, and actual speed is scaled in the drive so that the value of 20000 equals 1500 rpm, the value of 1000 in RAMP STOP LEVEL equals 75 rpm.

15 NO. OF DATASETS

This parameter defines the number of data sets (each consisting of three words, or six bytes) transmitted and received. Please note that different drives support different numbers of data sets; see the drive documentation.

1 ... 20

Note: The setting of this parameter can only be changed if the MUL. DATASETS assembly is selected at one of the configuration parameters 6, 7 or 8. The minimum value is in that case 2 (i.e. 2 data sets in each direction). Otherwise this parameter is read only, indicating the number of data sets in use. The number of data sets in use depends on the drive type (value 1 in case of ACS400 and ACS600 with application program version CSA 2.8/3.0) or selected assembly (value 1 in case of BASIC SPEED assembly and TRANSPARENT assembly; value 2 in case of PARAMETERS assembly).

Chapter 5 – Programming

Chapter 6 – Communication

Overview

This chapter describes the DeviceNet communication protocol for the NDNA-02 and the configuration of the scanner. For detailed information on DeviceNet communication, refer to ODVA DeviceNet Specifications Release 2.0.

Introduction to DeviceNet

DeviceNet is a protocol based on CAN technology. CAN specifies the physical layer interface. DeviceNet specifies the wiring, and the data transfer through CAN.

The NDNA-02 is a device acting as a Group 2 Only Server realising the Predefined Master Slave Connection Set functionality. The Offline Connection Set functionality and UCMM are not supported.

Object Modelling and Functional Profiles

One of the main features of DeviceNet is Object modelling. A group of Objects can be described with a Functional Profile. The NDNA-02 realises the ODVA AC/DC Drive Functional Profile with additional features. The supported Objects and their Services and Attributes are detailed in Appendix C.

Assembly Object

I/O Assembly Instances may also be referred to as Block Transfer of data. Intelligent devices, such as the NDNA-02, realising a Functional Profile have several objects. Since it is not possible to transmit more than one Object data through a single Connection, it is practical and more efficient to group Attributes from different Objects into a single I/O connection (for example a Polled Connection) using the Assembly Object. The Assembly Object acts as a tool for grouping these attributes.

The Assembly Selections described above are in fact Instances of the Assembly Object Class. The NDNA-02 uses Static Assemblies (in other words, fixed groupings of different object data only). These are predefined and cannot be changed.

The NDNA-02 communicates with the drive mainly using fast cyclic data set communication. The size and meaning of the data transmitted via data sets is predefined. Refer to the drive programming manual for explanation of the data set contents.

The following tables describe the predefined assembly instances supported by the NDNA-02.

Chapter 6 – Communication

**BASIC SPEED
Assembly**

BASIC SPEED Assembly is defined by ODVA AC/DC Drive Profile.
The format of the input assembly is:

Instance 20/101								
Byte	Bit 7	Bit 6	Bit 5	Bit 4	Bit 3	Bit 2	Bit 1	Bit 0
0						Fault Reset		Run Fwd
1								
2	Speed Reference (Low Byte)							
3	Speed Reference (High Byte)							

The format of the output assembly is:

Instance 70/105								
Byte	Bit 7	Bit 6	Bit 5	Bit 4	Bit 3	Bit 2	Bit 1	Bit 0
0						Running 1		Faulted
1	DDCS error							
2	Speed Actual Value (Low Byte)							
3	Speed Actual Value (High Byte)							

The unit of speed reference and actual is rpm. See SPEED REF. / ACT.
SCALE for scaling.

Note: If the BASIC SPEED assembly is used, it must be ensured that the following settings are in effect:

- Data Set 2 Word 2 (Data Word 2.2; Actual Value 1) is speed or frequency.
- External control location selection is set to either COMM. MODULE or EXT1.
- RUN ENABLE selection parameter is set to COMM. MODULE with ACS 600 Standard Application Program CSA 2.8 or CSA 3.0 in order to have an ODVA Drive Profile-compliant control logic.
- Speed or frequency reference and actual values are scaled correctly both in the drive and in the NDNA-02.
- Actual values and scaling values are set according to the programming manual of the drive.

Note: The BASIC SPEED assembly is not supported by ACS 1000.

**TRANSPARENT
Assembly**

The format of the input assembly is:

Instance 102									Data Set	Data Word
Byte	Bit 7	Bit 6	Bit 5	Bit 4	Bit 3	Bit 2	Bit 1	Bit 0		
0	Control Word (Low Byte)								DS1	DW1.1
1	Control Word (High Byte)									
2	Reference 1 (Low Byte)									DW1.2
3	Reference 1 (High Byte)									
4	Reference 2 (Low Byte)									DW1.3
5	Reference 2 (High Byte)									

The format of the output assembly is:

Instance 106									Data Set	Data Word
Byte	Bit 7	Bit 6	Bit 5	Bit 4	Bit 3	Bit 2	Bit 1	Bit 0		
0	Status Word (Low Byte)								DS2	DW2.1
1	Status Word (High Byte)									
2	Actual Value 1 (Low Byte)									DW2.2
3	Actual Value 1 (High Byte)									
4	Actual Value 2 (Low Byte)									DW2.3
5	Actual Value 2 (High Byte)									

**PARAMETERS
Assembly**

The format of the input assembly is:

Instance 103									Data Set	Data Word
Byte	Bit 7	Bit 6	Bit 5	Bit 4	Bit 3	Bit 2	Bit 1	Bit 0		
0	Reference 3 (Low Byte)								DS3	DW3.1
1	Reference 3 (High Byte)									
2	Reference 4 (Low Byte)									DW3.2
3	Reference 4 (High Byte)									
4	Reference 5 (Low Byte)									DW3.3
5	Reference 5 (High Byte)									

The format of the output assembly is:

Instance 107									Data Set	Data Word
Byte	Bit 7	Bit 6	Bit 5	Bit 4	Bit 3	Bit 2	Bit 1	Bit 0		
0	Actual Value 3 (Low Byte)								DS4	DW4.1
1	Actual Value 3 (High Byte)									
2	Actual Value 4 (Low Byte)									DW4.2
3	Actual Value 4 (High Byte)									
4	Actual Value 5 (Low Byte)									DW4.3
5	Actual Value 5 (High Byte)									

Chapter 6 – Communication

MUL. DATASETS Assembly The MUL. DATASETS (Multiple Data Sets) Assembly is a combination of the TRANSPARENT and PARAMETERS Assemblies.

The format of the input and output assemblies is shown below. The actual number of data sets used is selected with NDNA configuration parameter 15 NO. OF DATASETS. Refer to the drive documentation for information on how the Control Word and the References are used for controlling the drive, and on how Actual Signals are selected.

Instance 104 (Input)									Data Set*	Data Word*	
Byte	Bit 7	Bit 6	Bit 5	Bit 4	Bit 3	Bit 2	Bit 1	Bit 0			
0	Control Word (Low Byte)								DS1	DW1.1	
1	Control Word (High Byte)										
2	Reference 1 (Low Byte)										DW1.2
3	Reference 1 (High Byte)										
4	Reference 2 (Low Byte)										
5	Reference 2 (High Byte)										
6	Reference 3 (Low Byte)								DS3	DW3.1	
7	Reference 3 (High Byte)										
8	Reference 4 (Low Byte)										DW3.2
9	Reference 4 (High Byte)										
10	Reference 5 (Low Byte)										
11	Reference 5 (High Byte)										
12	Reference 6 (Low Byte)								DS5...	DW5.1	
13	Reference 6 (High Byte)										
...											
118	Reference 59 (Low Byte)								...DS39	DW39.3	
119	Reference 59 (High Byte)										

*If required (by drive application program), the data sets may be numbered so that the first data set is DS 10. See description of NDNA configuration parameter 10 DATASET INDEXES in Chapter 5.

Instance 108 (Output)									Data Set*	Data Word*
Byte	Bit 7	Bit 6	Bit 5	Bit 4	Bit 3	Bit 2	Bit 1	Bit 0		
0	Status Word (Low Byte)								DS2	DW2.1
1	Status Word (High Byte)									
2	Actual Value 1 (Low Byte)									DW2.2
3	Actual Value 1 (High Byte)									
4	Actual Value 2 (Low Byte)									DW2.3
5	Actual Value 2 (High Byte)									
6	Actual Value 3 (Low Byte)								DS4	DW4.1
7	Actual Value 3 (High Byte)									DW4.2
8	Actual Value 4 (Low Byte)									
9	Actual Value 4 (High Byte)									DW4.3
10	Actual Value 5 (Low Byte)									
11	Actual Value 5 (High Byte)								DS6...	DW6.1
12	Actual Value 6 (Low Byte)									
13	Actual Value 6 (High Byte)								...	
118	Actual Value 59 (Low Byte)								...DS40	DW40.3
119	Actual Value 59 (High Byte)									

*If required (by drive application program), the data sets may be numbered so that the first data set is DS 11. See description of NDNA configuration parameter 10 DATASET INDEXES in Chapter 5.

Note: When using the BASIC SPEED Assembly, the NDNA-02 transforms the ODVA defined data representation into one according to ABB Drives Profile or CSA2.8/3.0. When using the TRANSPARENT, PARAMETERS or MUL. DATASETS Assembly, the transformation is disabled. Refer to the drive documentation and previous chapter concerning the data transmitted in Transparent Assemblies.

Parameter Handling

With the NDNA-02, drive parameters can also be accessed. (Access to the drive parameters requires the Full EDS file – see further below). The function is implemented by employing the so-called Explicit Messaging properties of the DeviceNet protocol. Explicit Messaging makes use of objects consisting of three parts, *Class*, *Instance*, and *Attribute*.

Class is always 101 (65h). *Instance* and *Attribute* correspond to the drive parameter Group and Index in the following way:

- *Instance* = Parameter Group (0...99)
- *Attribute* = Parameter Index + 100 (101...199)

For example, Parameter 99.01 is accessed as follows:

- *Class* = 101 = 0x65
- *Instance* = 99 = 0x63
- *Attribute* = 101 = 0x66.

EDS Files

Electronic Data Sheet (EDS) files specify the properties of the device for the DeviceNet Scanner. The device is identified by the Scanner by means of the Product Type and Product Code definitions.

The allowable Product Types are defined by the ODVA DeviceNet specification. In the EDS files for the NDNA-02, only two Product Types are used:

- Product Type 2 = AC Drives
- Product Type 13 = DC Drives

To enable the use of different ABB drive types on the same DeviceNet network, a unique Product Code has been given to each drive and/or application program.

Product Code	Drive Type/Application Program
1	ACS 600 Standard Application Program 5.x
2	ACS 400
3	ACS 600 Standard Application Program CSA2.8/3.0
4	ACP 600 (ACS 600 Motion Control Application Program)
5	ACS 600 System Application Program
6	DCS 600
7	DCS 500
8	ACS 600 Application Program Template
9	ACS 600 Pump and Fan Control (PFC) Application Program
10	ACS 1000
11	DCS 400
12	Other ABB Drive
13	ACS 6000 Asynchronous Drive
14	ACS 6000 Twin Application
15	ACS 6000 Synchronous Drive
16	ACS 6000c Cycloconverter

Product Code	Drive Type/Application Program
17	ACS 600 Winder Application
18	ACS 600 Inline Application
19	ACS 600 Crane Application

The EDS files are available in Limited and Full formats. The Limited EDS files include the I/O Assembly configuration properties and the definition of the parameters in the fieldbus parameter group (see Chapter 5) only. The Limited EDS files can be used with the corresponding drive and/or application program independent of the application program revision.

The Full EDS files are intended for applications where access to the drive parameters via the DeviceNet network is required. The Full EDS files for ABB drives are specific to each drive type and application program revision. The Full EDS files are available from an ABB representative on request.

Editing EDS Files

By default, an EDS file is configured for polled connection and the Basic Speed Assembly for the input and output data. If any other configuration is required, the EDS file should be edited using a text editor such as Notepad or Wordpad, and saved as a text file. The following paragraphs describe the editing procedure.

Go to the '\$ -- FILE --' section and update the fields 'ModDate' and 'ModTime'. Increment the revision number (eg. from 0.2 to 0.3).

Updating these fields is very important as the DeviceNet configurator will not accept files with the same revision and/or modification date as the ones currently imported.

Go to the '\$ -- I/O INFO --' section and edit the selections in the fields 'Default', 'PollInfo', 'StrobeInfo' and 'COSInfo'. Each field contains three selections: connection type, type of Input Assembly, and type of Output Assembly.

The allowable connection types are Poll, Strobe, COS and Cyclic. Multiple simultaneous connections can be selected. (Note that the Strobe connection is not possible with the Multiple Data Sets Assembly.) Change the selection in the 'Default' field to the required value, eg. 0x0001 for Poll only, 0x0003 for Poll and Strobe, 0x0005 for Poll and COS, etc. The value at 'Default' should also be inserted into the 'PollInfo', 'StrobeInfo' and 'COSInfo' fields.

The numbers of the selected Input and Output Assemblies refer to the numbers in the sections '\$ Input Connections' and '\$ Output Connections' respectively.

Chapter 6 – Communication

The definitions of the input and output connections are predefined and do not require editing except for output connection 2. If output connection 2 is to be used in Strobe connection, the '\$ Size in Bytes' field should be set to 6. If input or output connection 4 ("Multiple Data Sets") is selected, '\$ Size in Bytes' should be changed such that the field equals the value of fieldbus configuration parameter **15 NO. OF DATASETS** multiplied with 6 (since each data set contains 6 bytes).

Do not edit the parameter section under '-- Parameter Class --'. Parameter editing is complicated and can easily cause syntax errors which result in the Scanner rejecting the file.

Chapter 7 – Fault Tracing

Overview

This chapter gives diagnostic information for finding out the root causes and corrections to the most common problems with the NDNA-02 module.

NDNA-02 Status Codes

This Status parameter indicates the status of the DeviceNet module.

SELF TEST

The module is initialising and performing self-test.

NO CONNECT

The module has completed its power-up sequence, and is waiting for a DeviceNet Scanner or the Manager software to establish a connection.

CONNECTED

The DeviceNet module is connected and communicating with a DeviceNet Scanner or Manager software.

TIME-OUT

The DeviceNet Scanner has stopped communicating with the NDNA-02 module. The Scanner might have been powered down.

Note: Timeout is only observed with I/O connections (Poll, Bit-strobe, COS/Cyclic) and not with explicit messaging connection.

DUP. MAC ERR

The module has observed another device with the same MAC ID in the network. Change the MAC ID value and switch the module power off and on.

BUS OFF

The module has detected an error on the DeviceNet wire physical communication, and is disconnected. To clear this state, switch the module power off and on.

COM. ERROR

Some other communication error (receive buffer overflow for example) has been detected by the module. Try switching the module power off and on. Also check the connections and increase Scanner interscan cycles.

WRONG ASMBLY

The drive does not support the chosen I/O assembly. See the I/O assembly selection parameter settings.

Status LEDs

There are three status LEDs on the NDNA-02 module, labelled *DDCS*, *NS* (Network Status) and *MS* (Module Status). The LEDs are bicolour (green/red) with white diffused lens.

The LED indications are as follows:

LED	Mode	Description
DDCS	Off	Not powered
	Flashing Green	DDCS initialisation in progress
	Green	DDCS communication established
	Flashing Red	DDCS communication errors
	Red	<ul style="list-style-type: none"> • DDCS communication failed, or • Module fault
NS	Off	Not on-line/Not powered: <ul style="list-style-type: none"> • Not powered (see <i>MS</i> LED), or • Dup_MAC_ID test not completed yet
	Flashing Green	On-line, but without connections in the established state: <ul style="list-style-type: none"> • Dup_MAC_ID test completed but no established connections to other nodes, or • Not allocated to a master
	Green	Link OK. On-line with connections in the established state. Allocated to a master
	Flashing Red	One or more connections are in timed-out state
	Red	Critical link failure. The module has detected an error that has rendered it incapable of communicating on the network (Duplicate MAC ID, or Bus-off)
MS	Off	Not powered
	Flashing Green	Stand-by. Module needs commissioning due to incomplete or incorrect configuration. E.g. wrong assembly selected
	Green	Operating in a normal condition
	Red	Unrecoverable fault
	Flashing Red–Green	Self test in progress

Installation Problems

Verify all the connections on the module:

- DeviceNet and power cables are connected to terminal blocks X1 and X2 as described in Chapter 4.
- DeviceNet power cable (if used) has sufficient 24 V d.c. regulated power connected to it.
- Fibre optic cables are connected between the correct channel of the drive and the NDNA-02 module.
- Check that the fibre optic cable connector colours match the drive and the NDNA-02 module connector colours.

Drive Setup

The fieldbus parameter group is not shown on the panel:

- Enable the NDNA-02 by setting the corresponding drive parameter.

The NDNA-02 is using default values:

- Verify that the fieldbus parameter group is set up correctly. If so, turn off and on the power to the NDNA module. This makes the module re-read its setup parameters.

Drive actual values can be read, but the control commands (start/stop or reference) do not go through:

- Check that the control location parameters of the drive are set to use the NDNA-02 as the source of the required command.
- Check that the drive is in REMOTE control.

PLC Programming

The PLC program is beyond ABB Drives support. Contact the manufacturer for assistance.

Scanner Fault Indications

Refer to scanner documentation. The latest revision is available at Allen-Bradley internet homepage <http://www.ab.com>.

Chapter 7 – Fault Tracing

Appendix A – Technical Data

DDCS Link

Compatible Devices: All ABB Fieldbus Adapter modules, ABB ACS 400, ACS/ACP/ACF 600, DCS 500, DCS 600, ACS 1000 Drives.

Size of the Link: 2 stations

Medium: Fibre optic cable

- Construction: Plastic core, diameter 1 mm, sheathed with plastic jacket
- Attenuation: 0.31 dB/m
- Maximum Length between Stations: 10 m
- Specifications:

Parameter	Minimum	Maximum	Unit
Storage Temperature	-55	+85	°C
Installation Temperature	-20	+70	°C
Short Term Tensile Force		50	N
Short Term Bend Radius	25		mm
Long Term Bend Radius	35		mm
Long Term Tensile Load		1	N
Flexing		1000	cycles

Topology: Point-to-point

Serial Communication Type: Asynchronous, half Duplex

Transfer Rate: 4 Mbit/s

Protocol: Distributed Drives Communication System (DDCS)

Connectors: Blue – receiver; grey – transmitter

Appendix A – Technical Data

Fieldbus Link

Compatible Devices: Any ODVA compliant DeviceNet scanner supporting Poll - Response and/or Bit - Strobe commands to Class-2 Only Slaves

Medium: Shielded, twisted pair RS485 cable

- Termination: 121 Ω , 1%, Metal Film, 1/4 W
- DeviceNet Cables:
YR-29790 (Thick DeviceNet Cable)
YR-29832 (Thin DeviceNet Cable)
- Maximum Bus Length: 1200 m

Topology: Multi-drop

Serial Communication Type: Asynchronous, half Duplex

Transfer Rate: 125, 250 or 500 kBit/s

Protocol: DeviceNet

NDNA-02

Enclosure: Plastic, dimensions 100 × 22.5 × 115 mm (H×W×D); degree of protection IP20

Mounting: Onto a standard mounting rail

Settings: Through drive parameters and/or DIP switches

Current Consumption: 70 mA at 24 V d.c.

Connectors:

- Light transmitter (grey) and receiver (blue) (Hewlett-Packard Versatile Link) for connection to the drive
- Two Combicon MSTBT 2,5/4-ST (4-pole, cross-section 2.5 mm² max.) screw terminal blocks for CAN network and power supply connection:

X1		Description	
1	0 V	DC GND	Power supply ground (0 V). If the power to the module is supplied through the DeviceNet network, this terminal should be left unconnected.
2	UC	+24 VDC	+24 V ±10% (70 mA) d.c. supply to the module. The power can be taken from the drive's internal power supply (see drive manuals), a dedicated external power supply, or through the DeviceNet network. The on-board power supply is disabled if the voltage drops below 11 V.
3	EXT	DC GND	These terminals should be connected together if the power to the module is supplied through the DeviceNet network. This makes the NDNA-02 a non-isolated node.
4		CAN GND	

X2		Description	
5	SHLD	Network cable shield.	
6	CAN_L	CAN_L bus line.	
7	GND	CAN bus ground (digital ground).	
8	CAN_H	CAN_H bus line.	

General:

- All materials are UL/CSA approved
- Complies with EMC Standards EN 50081-2 and EN 50082-2

Appendix A – Technical Data

Appendix B – Ambient Conditions

Ambient Conditions, Operation

Ambient operating conditions refer to the conditions the option module is subjected to when installed for stationary use.

Air Temperature: 0 to +50 °C

Relative Humidity: 5 to 95 %, no condensation allowed. Maximum allowed relative humidity is 60 % in the presence of corrosive gases.

Contamination Levels:

Chemical gases: IEC 60721-3-3, Class 3C2

Solid particles: IEC 60721-3-3, Class 3S2

Installation Site Altitude: 0 to 2000 m. If the installation site is above 2000 m, contact local ABB representative.

Vibration: Max 0.3 mm (2 to 9 Hz), max 1 m/s² (9 to 200 Hz) sinusoidal (IEC 60068-2-6)

Shock: Max 70 m/s², 22 ms (IEC 60068-2-27)

Ambient Conditions, Storage

Ambient storage conditions refer to the conditions the option module is subjected to during storage in the protective package.

Temperature: -40 to +70 °C.

Relative Humidity: Less than 95 %, no condensation allowed

Atmospheric Pressure: 70 to 106 kPa

Vibration: Max 0.3 mm (2 to 9 Hz), max 1 m/s² (9 to 200 Hz) sinusoidal (IEC 60068-2-6)

Shock: Max 100 m/s², 11 ms (IEC 60068-2-27)

Ambient Conditions, Transportation

Ambient transportation conditions refer to the conditions the option module is subjected to during transportation in the protective package.

Temperature: -40 to +70 °C

Relative Humidity: Less than 95 %, no condensation allowed.

Atmospheric Pressure: 60 to 106 kPa

Vibration: Max 3.5 mm (2 to 9 Hz), max 15 m/s² (9 to 200 Hz) sinusoidal (IEC 60068-2-6)

Shock: Max 100 m/s², 11 ms (IEC 60068-2-27)

Bump: Max 300 m/s², 6 ms (IEC 60068-2-29)

Free Fall: 250 mm

Appendix B – Ambient Conditions

Appendix C – Statement of Compliance

General Device Data	Conforms to DeviceNet Specification	Volume I - Release	2	Volume II - Release	2		
	Vendor Name	ABB Industry					
	Device Profile Name	AC/DC Drive					
	Product Name	NDNA-02 V2.1					
	Product Catalog Number						
	Product Revision	Rev. A					
DeviceNet Physical Conformance Data	Network Power Consumption (Max)	<u>0.25 A @ 11V dc (worst case)</u>					
	Connector Style	Open-Hardwired	<input type="checkbox"/>	Sealed-Mini	<input type="checkbox"/>		
		Open-Pluggable	<input checked="" type="checkbox"/>	Sealed-Micro	<input type="checkbox"/>		
	Isolated Physical Layer	Yes	<input checked="" type="checkbox"/>				
		No	<input type="checkbox"/>				
	LEDs Supported	Module	<input checked="" type="checkbox"/>	Combo Mod/Net	<input type="checkbox"/>		
		None <input type="checkbox"/>	Network	<input checked="" type="checkbox"/>	I/O	<input checked="" type="checkbox"/>	
	MAC ID Setting	DIP Switch	<input checked="" type="checkbox"/>	Software Settable	<input checked="" type="checkbox"/>		
		Other	<i>Through DeviceNet, control panel and DIPs</i>				
	Default MAC ID	63					
	Communication Rate Setting	DIP Switch	<input checked="" type="checkbox"/>	Software Settable	<input checked="" type="checkbox"/>		
		Other	<i>Through DeviceNet, control panel and DIPs</i>				
Communication Rates Supported	125k bit/s	<input checked="" type="checkbox"/>	500k bit/s	<input checked="" type="checkbox"/>			
	250k bit/s	<input checked="" type="checkbox"/>					
DeviceNet Communication Data	Device Network Behavior Check All That Apply	Group 2 Client	<input type="checkbox"/>	Group 2 Only Client	<input type="checkbox"/>		
		Group 2 Server	<input type="checkbox"/>	Group 2 Only Server	<input checked="" type="checkbox"/>		
		Peer-To-Peer	<input type="checkbox"/>	Tool (not a Device)	<input type="checkbox"/>		
	UCMM Explicit Message Groups Supported	Group 1	<input type="checkbox"/>	Group 2	<input type="checkbox"/>	Group 3	<input type="checkbox"/>
		Dynamic I/O Message Groups (Peer to Peer)	Group 1	<input type="checkbox"/>	Group 2	<input type="checkbox"/>	Group 3
	Default I/O Data Address Path	Input: Class	4	Inst. 70	Attr. 3		
		Output: Class	4	Inst. 20	Attr. 3		
	Fragmented Explicit Messaging Supported	Yes	<input checked="" type="checkbox"/>	No	<input type="checkbox"/>		
		If yes, Acknowledge TimeOut	<u>1000 ms</u>				
	Typical Target Addresses						
	Consumption	Service	16	Class	3	Inst. 1	Attr. 1
	Production	Service	14	Class	3	Inst. 1	Attr. 1

DeviceNet Required		Identity Object 0x01				
Object Implementation	Object Class	ID	Description	Get	Set	Value Limits
<input type="checkbox"/> None Supported	Attributes Open	1	Revision	<input checked="" type="checkbox"/>	<input type="checkbox"/>	
		2	Max instance	<input type="checkbox"/>	<input type="checkbox"/>	
		3	Number of Instances	<input type="checkbox"/>	<input type="checkbox"/>	
		4	Optional attributes list	<input type="checkbox"/>	<input type="checkbox"/>	
		5	Optional services list	<input type="checkbox"/>	<input type="checkbox"/>	
		6	Max Id of class attributes	<input type="checkbox"/>	<input type="checkbox"/>	
		7	Max Id of instance attributes	<input type="checkbox"/>	<input type="checkbox"/>	
		DeviceNet Services		Parameter Options		
<input type="checkbox"/> None Supported	Services	<input type="checkbox"/>	Get_Attributes_All			
		<input type="checkbox"/>	Reset			
		<input checked="" type="checkbox"/>	Get_Attribute_Single			
		<input type="checkbox"/>	Find_Next_Object_instance			
Object Instance		ID	Description	Get	Set	Value Limits
	Attributes Open	1	Vendor	<input checked="" type="checkbox"/>	<input type="checkbox"/>	46
		2	Device type	<input checked="" type="checkbox"/>	<input type="checkbox"/>	2 / 19
		3	Product code	<input checked="" type="checkbox"/>	<input type="checkbox"/>	01 = ACS600 02 = ACS400 03 = ACS600_O 04 = ACP600 05 = ACN600 06 = DCS600 07 = DCS500 08 = ACT600 09 = ACH600 10 = ACS1000 11 = DCS400 12 = Unknown
		4	Revision	<input checked="" type="checkbox"/>	<input type="checkbox"/>	2.00
		5	Status (bits supported)	<input checked="" type="checkbox"/>	<input type="checkbox"/>	bits: 0, 2
		6	Serial number	<input checked="" type="checkbox"/>	<input type="checkbox"/>	1
		7	Product name	<input checked="" type="checkbox"/>	<input type="checkbox"/>	NDNA-02 Version V2.1
		8	State	<input type="checkbox"/>	<input type="checkbox"/>	
		9	Config. Consistency Value	<input type="checkbox"/>	<input type="checkbox"/>	
		10	Heartbeat Interval	<input type="checkbox"/>	<input type="checkbox"/>	
		DeviceNet Services		Parameter Options		
	Services	<input type="checkbox"/>	Get_Attributes_All			
		<input checked="" type="checkbox"/>	Reset	1		
		<input checked="" type="checkbox"/>	Get_Attribute_Single			
		<input type="checkbox"/>	Set_Attribute_Single			
Vendor Specific Additions		If yes, fill out the Vendor Specific Additions form.		Yes	<input type="checkbox"/>	
				No	<input checked="" type="checkbox"/>	

Get to indicate that attribute value is returned by the use of Get_Attribute_Single service.
 Set to indicate that attribute value is written to by the use of Set_Attribute_Single service.

DeviceNet Required		Message Router Object 0x02				
Object Implementation	Object Class	ID	Description	Get	Set	Value Limits
	Attributes Open	1	Revision	<input type="checkbox"/>	<input type="checkbox"/>	
		4	Optional attribute list	<input type="checkbox"/>	<input type="checkbox"/>	
<input checked="" type="checkbox"/>	None Supported	5	Optional service list	<input type="checkbox"/>	<input type="checkbox"/>	
		6	Max ID of class attributes	<input type="checkbox"/>	<input type="checkbox"/>	
		7	Max ID of instance attributes	<input type="checkbox"/>	<input type="checkbox"/>	
		DeviceNet Services		Parameter Options		
	Services	<input type="checkbox"/>	Get_Attributes_All			
		<input type="checkbox"/>	Get_Attribute_Single			
<input checked="" type="checkbox"/>	None Supported					
Object Instance	Object Class	ID	Description	Get	Set	Value Limits
	Attributes Open	1	Object list	<input type="checkbox"/>	<input type="checkbox"/>	
		2	Maximum connections supported	<input type="checkbox"/>	<input type="checkbox"/>	
<input checked="" type="checkbox"/>	None Supported	3	Number of active connections	<input type="checkbox"/>	<input type="checkbox"/>	
		4	Active connections list	<input type="checkbox"/>	<input type="checkbox"/>	
		DeviceNet Services		Parameter Options		
	Services	<input type="checkbox"/>	Get_Attributes_All			
		<input type="checkbox"/>	Get_Attribute_Single			
<input checked="" type="checkbox"/>	None Supported					
Vendor Specific Additions		If yes, fill out the Vendor Specific Additions form.		Yes	<input type="checkbox"/>	
				No	<input checked="" type="checkbox"/>	

Get to indicate that attribute value is returned by the use of Get_Attribute_Single service.

Set to indicate that attribute value is written to by the use of Set_Attribute_Single service.

DeviceNet Required		DeviceNet Object 0x03				
Object Class		ID	Description	Get	Set	Value Limits
Attributes	Open	1	Revision	<input checked="" type="checkbox"/>	<input type="checkbox"/>	
Implementation						
<input type="checkbox"/> None Supported						
			DeviceNet Services		Parameter Options	
Services		<input checked="" type="checkbox"/>	Get_Attribute_Single			
<input type="checkbox"/> None Supported						
Object Instance		ID	Description	Get	Set	Value Limits
Attributes	Open	1	MAC ID	<input checked="" type="checkbox"/>	<input checked="" type="checkbox"/>	
		2	Baud rate	<input checked="" type="checkbox"/>	<input checked="" type="checkbox"/>	
		3	BOI	<input checked="" type="checkbox"/>	<input checked="" type="checkbox"/>	
		4	Bus-off counter	<input checked="" type="checkbox"/>	<input checked="" type="checkbox"/>	
		5	Allocation information	<input checked="" type="checkbox"/>	<input type="checkbox"/>	
		6	MAC ID switch changed	<input type="checkbox"/>	<input type="checkbox"/>	
		7	Baud rate switch changed	<input type="checkbox"/>	<input type="checkbox"/>	
		8	MAC ID switch value	<input type="checkbox"/>	<input type="checkbox"/>	
		9	Baud rate switch value	<input type="checkbox"/>	<input type="checkbox"/>	
			DeviceNet Services		Parameter Options	
Services		<input checked="" type="checkbox"/>	Get_Attribute_Single			
		<input checked="" type="checkbox"/>	Set_Attribute_Single			
		<input checked="" type="checkbox"/>	Allocate M/S connection set			
		<input checked="" type="checkbox"/>	Release M/S connection set			
<input type="checkbox"/> None Supported						
Vendor Specific Additions		If yes, fill out the Vendor Specific Additions form.		Yes	<input type="checkbox"/>	
				No	<input checked="" type="checkbox"/>	

Get to indicate that attribute value is returned by the use of Get_Attribute_Single service.
 Set to indicate that attribute value is written to by the use of Set_Attribute_Single service.

DeviceNet Required		Connection Object 0x05				
Object Implementation	Object Class	ID	Description	Get	Set	Value Limits
	Attributes Open	1	Revision	<input checked="" type="checkbox"/>	<input type="checkbox"/>	
<input type="checkbox"/> None Supported						
			DeviceNet Services	Parameter Options		
Services			<input type="checkbox"/> Reset			
			<input type="checkbox"/> Create			
<input type="checkbox"/> None Supported			<input type="checkbox"/> Delete			
			<input checked="" type="checkbox"/> Get_Attribute_Single			
			<input type="checkbox"/> Find_Next_Object_Instance			
Object Instance	Predefined M/S Connections		Peer to Peer Connections		Max Instances	
<i>Complete the Object Instance section for each Instance type supported. Indicate Production trigger, Transport type and Transport Class supported for Dynamic I/O.</i>	Explicit Message		<input checked="" type="checkbox"/>	Explicit Message	<input type="checkbox"/>	Total
	Polled		<input type="checkbox"/>	Server		Client
	Bit Strobed		<input type="checkbox"/>	Dynamic I/O	<input type="checkbox"/>	Total
	Change of State		<input type="checkbox"/>	Server		Client
	Cyclic		<input type="checkbox"/>			
	Production trigger(s)		Cyclic	<input type="checkbox"/>	COS	<input type="checkbox"/>
Transport type(s)		Server	<input checked="" type="checkbox"/>			Client <input type="checkbox"/>
Transport class(es)			<input type="checkbox"/>	2	<input type="checkbox"/>	3 <input checked="" type="checkbox"/>
		ID	Description	Get	Set	Value Limits
Attributes Open		1	State	<input checked="" type="checkbox"/>	<input type="checkbox"/>	
		2	Instance type	<input checked="" type="checkbox"/>	<input type="checkbox"/>	
		3	Transport Class trigger	<input checked="" type="checkbox"/>	<input type="checkbox"/>	
		4	Produced connection ID	<input checked="" type="checkbox"/>	<input type="checkbox"/>	
		5	Consumed connection ID	<input checked="" type="checkbox"/>	<input type="checkbox"/>	
		6	Initial comm. characteristics	<input checked="" type="checkbox"/>	<input type="checkbox"/>	
		7	Produced connection size	<input checked="" type="checkbox"/>	<input type="checkbox"/>	
		8	Consumed connection size	<input checked="" type="checkbox"/>	<input type="checkbox"/>	
		9	Expected packet rate	<input checked="" type="checkbox"/>	<input checked="" type="checkbox"/>	
		12	Watchdog time-out action	<input checked="" type="checkbox"/>	<input checked="" type="checkbox"/>	
		13	Produced connection path length	<input checked="" type="checkbox"/>	<input type="checkbox"/>	
		14	Produced connection path	<input checked="" type="checkbox"/>	<input type="checkbox"/>	
		15	Consumed connection path length	<input checked="" type="checkbox"/>	<input type="checkbox"/>	
		16	Consumed connection path	<input checked="" type="checkbox"/>	<input type="checkbox"/>	
		17	Production inhibit time	<input checked="" type="checkbox"/>	<input type="checkbox"/>	
			DeviceNet Services	Parameter Options		
Services			<input checked="" type="checkbox"/> Reset			
			<input type="checkbox"/> Delete			
			<input type="checkbox"/> Apply_Attributes			
			<input checked="" type="checkbox"/> Get_Attribute_Single			
			<input checked="" type="checkbox"/> Set_Attribute_Single			
Vendor Specific Additions		If yes, fill out the Vendor Specific Additions form.		Yes	<input type="checkbox"/>	
				No	<input checked="" type="checkbox"/>	

Get to indicate that attribute value is returned by the use of Get_Attribute_Single service.
 Set to indicate that attribute value is written to by the use of Set_Attribute_Single service.

DeviceNet Required		Connection Object 0x05				
Object Implementation	Object Class	ID	Description	Get	Set	Value Limits
	Attributes Open	1	Revision	<input checked="" type="checkbox"/>	<input type="checkbox"/>	
<input type="checkbox"/> None Supported						
			DeviceNet Services		Parameter Options	
Services			<input type="checkbox"/> Reset			
			<input type="checkbox"/> Create			
<input type="checkbox"/> None Supported			<input type="checkbox"/> Delete			
			<input checked="" type="checkbox"/> Get_Attribute_Single			
			<input type="checkbox"/> Find_Next_Object_Instance			
Object Instance		Predefined M/S Connections		Peer to Peer Connections		Max Instances
<i>Complete the Object Instance section for each Instance type supported. Indicate Production trigger, Transport type and Transport Class supported for Dynamic I/O.</i>		Explicit Message	<input type="checkbox"/>	Explicit Message	<input type="checkbox"/>	Total
		Polled	<input type="checkbox"/>	Server		Client
		Bit Strobed	<input type="checkbox"/>	Dynamic I/O	<input type="checkbox"/>	Total
		Change of State	<input checked="" type="checkbox"/>	Server		Client
		Cyclic	<input type="checkbox"/>			
Production trigger(s)		Cyclic	<input type="checkbox"/>	COS	<input type="checkbox"/>	App. trig. <input type="checkbox"/>
Transport type(s)		Server	<input type="checkbox"/>			Client <input type="checkbox"/>
Transport class(es)			<input type="checkbox"/>	2	<input type="checkbox"/>	3 <input type="checkbox"/>
		ID	Description	Get	Set	Value Limits
Attributes Open		1	State	<input checked="" type="checkbox"/>	<input type="checkbox"/>	
		2	Instance type	<input checked="" type="checkbox"/>	<input type="checkbox"/>	
		3	Transport Class trigger	<input checked="" type="checkbox"/>	<input type="checkbox"/>	
		4	Produced connection ID	<input checked="" type="checkbox"/>	<input type="checkbox"/>	
		5	Consumed connection ID	<input checked="" type="checkbox"/>	<input type="checkbox"/>	
		6	Initial comm. characteristics	<input type="checkbox"/>	<input type="checkbox"/>	
		7	Produced connection size	<input checked="" type="checkbox"/>	<input type="checkbox"/>	
		8	Consumed connection size	<input checked="" type="checkbox"/>	<input type="checkbox"/>	
		9	Expected packet rate	<input checked="" type="checkbox"/>	<input checked="" type="checkbox"/>	
		12	Watchdog time-out action	<input checked="" type="checkbox"/>	<input type="checkbox"/>	
		13	Produced connection path length	<input checked="" type="checkbox"/>	<input type="checkbox"/>	
		14	Produced connection path	<input checked="" type="checkbox"/>	<input type="checkbox"/>	
		15	Consumed connection path length	<input checked="" type="checkbox"/>	<input type="checkbox"/>	
		16	Consumed connection path	<input checked="" type="checkbox"/>	<input type="checkbox"/>	
		17	Production inhibit time	<input checked="" type="checkbox"/>	<input type="checkbox"/>	
			DeviceNet Services		Parameter Options	
Services			<input checked="" type="checkbox"/> Reset			
			<input type="checkbox"/> Delete			
			<input type="checkbox"/> Apply_Attributes			
			<input checked="" type="checkbox"/> Get_Attribute_Single			
			<input checked="" type="checkbox"/> Set_Attribute_Single			
Vendor Specific Additions				If yes, fill out the Vendor Specific Additions form.	Yes <input type="checkbox"/>	No <input checked="" type="checkbox"/>

Get to indicate that attribute value is returned by the use of Get_Attribute_Single service.
 Set to indicate that attribute value is written to by the use of Set_Attribute_Single service.

DeviceNet Required		Connection Object 0x05				
Object Implementation	Object Class	ID	Description	Get	Set	Value Limits
	Attributes Open	1	Revision	<input checked="" type="checkbox"/>	<input type="checkbox"/>	
<input type="checkbox"/> None Supported						
			DeviceNet Services	Parameter Options		
Services			<input type="checkbox"/> Reset			
			<input type="checkbox"/> Create			
<input type="checkbox"/> None Supported			<input type="checkbox"/> Delete			
			<input checked="" type="checkbox"/> Get_Attribute_Single			
			<input type="checkbox"/> Find_Next_Object_Instance			
Object Instance	Predefined M/S Connections			Peer to Peer Connections		Max Instances
<i>Complete the Object Instance section for each Instance type supported. Indicate Production trigger, Transport type and Transport Class supported for Dynamic I/O.</i>	Explicit Message		<input type="checkbox"/>	Explicit Message		<input type="checkbox"/> Total
	Polled		<input type="checkbox"/>	Server		Client
	Bit Strobed		<input type="checkbox"/>	Dynamic I/O		<input type="checkbox"/> Total
	Change of State		<input type="checkbox"/>	Server		Client
	Cyclic		<input checked="" type="checkbox"/>			
	Production trigger(s)		Cyclic	<input type="checkbox"/>	COS	<input type="checkbox"/>
Transport type(s)		Server	<input type="checkbox"/>			Client <input type="checkbox"/>
Transport class(es)			<input type="checkbox"/>	2	<input type="checkbox"/>	3 <input type="checkbox"/>
		ID	Description	Get	Set	Value Limits
Attributes Open		1	State	<input checked="" type="checkbox"/>	<input type="checkbox"/>	
		2	Instance type	<input checked="" type="checkbox"/>	<input type="checkbox"/>	
		3	Transport Class trigger	<input checked="" type="checkbox"/>	<input type="checkbox"/>	
		4	Produced connection ID	<input checked="" type="checkbox"/>	<input type="checkbox"/>	
		5	Consumed connection ID	<input checked="" type="checkbox"/>	<input type="checkbox"/>	
		6	Initial comm. characteristics	<input type="checkbox"/>	<input type="checkbox"/>	
		7	Produced connection size	<input checked="" type="checkbox"/>	<input type="checkbox"/>	
		8	Consumed connection size	<input checked="" type="checkbox"/>	<input type="checkbox"/>	
		9	Expected packet rate	<input checked="" type="checkbox"/>	<input checked="" type="checkbox"/>	
		12	Watchdog time-out action	<input checked="" type="checkbox"/>	<input type="checkbox"/>	
		13	Produced connection path length	<input checked="" type="checkbox"/>	<input type="checkbox"/>	
		14	Produced connection path	<input checked="" type="checkbox"/>	<input type="checkbox"/>	
		15	Consumed connection path length	<input checked="" type="checkbox"/>	<input type="checkbox"/>	
		16	Consumed connection path	<input checked="" type="checkbox"/>	<input type="checkbox"/>	
		17	Production inhibit time	<input checked="" type="checkbox"/>	<input type="checkbox"/>	
			DeviceNet Services	Parameter Options		
Services			<input checked="" type="checkbox"/> Reset			
			<input type="checkbox"/> Delete			
			<input type="checkbox"/> Apply_Attributes			
			<input checked="" type="checkbox"/> Get_Attribute_Single			
			<input checked="" type="checkbox"/> Set_Attribute_Single			
Vendor Specific Additions				Yes	<input type="checkbox"/>	
If yes, fill out the Vendor Specific Additions form.				No	<input checked="" type="checkbox"/>	

Get to indicate that attribute value is returned by the use of Get_Attribute_Single service.
 Set to indicate that attribute value is written to by the use of Set_Attribute_Single service.

DeviceNet Required		Connection Object 0x05						
Object Implementation	Object Class	ID	Description	Get	Set	Value Limits		
	Attributes Open	1	Revision	<input checked="" type="checkbox"/>	<input type="checkbox"/>			
<input type="checkbox"/> None Supported								
			DeviceNet Services	Parameter Options				
Services			<input type="checkbox"/> Reset					
			<input type="checkbox"/> Create					
<input type="checkbox"/> None Supported			<input type="checkbox"/> Delete					
			<input checked="" type="checkbox"/> Get_Attribute_Single					
			<input type="checkbox"/> Find_Next_Object_Instance					
Object Instance	Predefined M/S Connections			Peer to Peer Connections		Max Instances		
<i>Complete the Object Instance section for each Instance type supported. Indicate Production trigger, Transport type and Transport Class supported for Dynamic I/O.</i>	Explicit Message			<input type="checkbox"/>	Explicit Message	<input type="checkbox"/> Total		
	Polled			<input type="checkbox"/>	Server	Client		
	Bit Strobed			<input checked="" type="checkbox"/>	Dynamic I/O	<input type="checkbox"/> Total		
	Change of State			<input type="checkbox"/>	Server	Client		
	Cyclic			<input type="checkbox"/>				
Production trigger(s)		Cyclic	<input type="checkbox"/>	COS	<input type="checkbox"/>	App. trig. <input type="checkbox"/>		
Transport type(s)		Server	<input type="checkbox"/>			Client <input type="checkbox"/>		
Transport class(es)			<input type="checkbox"/>	2	<input type="checkbox"/>	3 <input type="checkbox"/>		
		ID	Description	Get	Set	Value Limits		
Attributes	Open	1	State	<input checked="" type="checkbox"/>	<input type="checkbox"/>			
		2	Instance type	<input checked="" type="checkbox"/>	<input type="checkbox"/>			
		3	Transport Class trigger	<input checked="" type="checkbox"/>	<input type="checkbox"/>			
		4	Produced connection ID	<input checked="" type="checkbox"/>	<input type="checkbox"/>			
		5	Consumed connection ID	<input checked="" type="checkbox"/>	<input type="checkbox"/>			
		6	Initial comm. characteristics	<input checked="" type="checkbox"/>	<input type="checkbox"/>			
		7	Produced connection size	<input checked="" type="checkbox"/>	<input type="checkbox"/>			
		8	Consumed connection size	<input checked="" type="checkbox"/>	<input type="checkbox"/>			
		9	Expected packet rate	<input checked="" type="checkbox"/>	<input checked="" type="checkbox"/>			
		12	Watchdog time-out action	<input checked="" type="checkbox"/>	<input type="checkbox"/>			
		13	Produced connection path length	<input checked="" type="checkbox"/>	<input type="checkbox"/>			
		14	Produced connection path	<input checked="" type="checkbox"/>	<input type="checkbox"/>			
		15	Consumed connection path length	<input checked="" type="checkbox"/>	<input type="checkbox"/>			
		16	Consumed connection path	<input checked="" type="checkbox"/>	<input type="checkbox"/>			
		17	Production inhibit time	<input checked="" type="checkbox"/>	<input type="checkbox"/>			
					DeviceNet Services	Parameter Options		
		Services			<input checked="" type="checkbox"/> Reset			
			<input type="checkbox"/> Delete					
			<input type="checkbox"/> Apply_Attributes					
			<input checked="" type="checkbox"/> Get_Attribute_Single					
			<input checked="" type="checkbox"/> Set_Attribute_Single					
Vendor Specific Additions				If yes, fill out the Vendor Specific Additions form.	Yes <input type="checkbox"/>	No <input checked="" type="checkbox"/>		

Get to indicate that attribute value is returned by the use of Get_Attribute_Single service.
 Set to indicate that attribute value is written to by the use of Set_Attribute_Single service.

DeviceNet Required		Connection Object 0x05						
Object Implementation	Object Class	ID	Description	Get	Set	Value Limits		
	Attributes Open	1	Revision	<input checked="" type="checkbox"/>	<input type="checkbox"/>			
<input type="checkbox"/> None Supported								
			DeviceNet Services	Parameter Options				
Services			<input type="checkbox"/> Reset					
			<input type="checkbox"/> Create					
<input type="checkbox"/> None Supported			<input type="checkbox"/> Delete					
			<input checked="" type="checkbox"/> Get_Attribute_Single					
			<input type="checkbox"/> Find_Next_Object_Instance					
Object Instance	Predefined M/S Connections			Peer to Peer Connections		Max Instances		
<i>Complete the Object Instance section for each Instance type supported. Indicate Production trigger, Transport type and Transport Class supported for Dynamic I/O.</i>	Explicit Message		<input type="checkbox"/>	Explicit Message		<input type="checkbox"/> Total		
	Polled		<input checked="" type="checkbox"/>	Server		Client		
	Bit Strobed		<input type="checkbox"/>	Dynamic I/O		<input type="checkbox"/> Total		
	Change of State		<input type="checkbox"/>	Server		Client		
	Cyclic		<input type="checkbox"/>					
	Production trigger(s)		Cyclic	<input type="checkbox"/>	COS	<input type="checkbox"/>	App. trig. <input type="checkbox"/>	
Transport type(s)		Server	<input type="checkbox"/>			Client <input type="checkbox"/>		
Transport class(es)			<input type="checkbox"/>	2	<input type="checkbox"/>	3 <input type="checkbox"/>		
		ID	Description	Get	Set	Value Limits		
Attributes	Open	1	State	<input checked="" type="checkbox"/>	<input type="checkbox"/>			
		2	Instance type	<input checked="" type="checkbox"/>	<input type="checkbox"/>			
		3	Transport Class trigger	<input checked="" type="checkbox"/>	<input type="checkbox"/>			
		4	Produced connection ID	<input checked="" type="checkbox"/>	<input type="checkbox"/>			
		5	Consumed connection ID	<input checked="" type="checkbox"/>	<input type="checkbox"/>			
		6	Initial comm. characteristics	<input type="checkbox"/>	<input type="checkbox"/>			
		7	Produced connection size	<input checked="" type="checkbox"/>	<input type="checkbox"/>			
		8	Consumed connection size	<input checked="" type="checkbox"/>	<input type="checkbox"/>			
		9	Expected packet rate	<input checked="" type="checkbox"/>	<input checked="" type="checkbox"/>			
		12	Watchdog time-out action	<input checked="" type="checkbox"/>	<input type="checkbox"/>			
		13	Produced connection path length	<input checked="" type="checkbox"/>	<input type="checkbox"/>			
		14	Produced connection path	<input checked="" type="checkbox"/>	<input type="checkbox"/>			
		15	Consumed connection path length	<input checked="" type="checkbox"/>	<input type="checkbox"/>			
		16	Consumed connection path	<input checked="" type="checkbox"/>	<input type="checkbox"/>			
		17	Production inhibit time	<input checked="" type="checkbox"/>	<input type="checkbox"/>			
					DeviceNet Services	Parameter Options		
		Services			<input checked="" type="checkbox"/> Reset			
			<input type="checkbox"/> Delete					
			<input type="checkbox"/> Apply_Attributes					
			<input checked="" type="checkbox"/> Get_Attribute_Single					
			<input checked="" type="checkbox"/> Set_Attribute_Single					
Vendor Specific Additions				If yes, fill out the Vendor Specific Additions form.	Yes	<input type="checkbox"/>		
					No	<input checked="" type="checkbox"/>		

Get to indicate that attribute value is returned by the use of Get_Attribute_Single service.
 Set to indicate that attribute value is written to by the use of Set_Attribute_Single service.

DeviceNet Required		Assembly Object 0x04				
Object Class	ID	Description	Get	Set	Value Limits	
Attributes Open	1	Revision	<input checked="" type="checkbox"/>	<input type="checkbox"/>		
<input type="checkbox"/> None Supported	2	Max instance	<input checked="" type="checkbox"/>	<input type="checkbox"/>	20 – 108	
		DeviceNet Services		Parameter Options		
Services	<input type="checkbox"/>	Create				
	<input type="checkbox"/>	Delete				
<input type="checkbox"/> None Supported	<input checked="" type="checkbox"/>	Get_Attribute_Single				
Object Instance		Instance Type		Instance Id(s)		
<i>The Object Instance section must be completed for each instance type implemented.</i>		Static Input	<input checked="" type="checkbox"/>	70, 105, 106, 107, 108		
		Static Output	<input type="checkbox"/>			
Object Class	ID	Description	Get	Set	Value Limits	
Attributes Open	1	Number of members in list	<input type="checkbox"/>	<input type="checkbox"/>		
	2	Member list	<input type="checkbox"/>	<input type="checkbox"/>		
<input type="checkbox"/> None Supported	3	Data	<input checked="" type="checkbox"/>	<input type="checkbox"/>		
		DeviceNet Services		Parameter Options		
Services	<input type="checkbox"/>	Delete				
	<input checked="" type="checkbox"/>	Get_Attribute_Single				
<input type="checkbox"/> None Supported	<input type="checkbox"/>	Set_Attribute_Single				
	<input type="checkbox"/>	Get_Member				
	<input type="checkbox"/>	Insert_Member				
	<input type="checkbox"/>	Remove_Member				
Vendor Specific Additions		If yes, fill out the Vendor Specific Additions form.	Yes	<input type="checkbox"/>		
			No	<input checked="" type="checkbox"/>		



Get to indicate that attribute value is returned by the use of Get_Attribute_Single service.



Set to indicate that attribute value is written to by the use of Set_Attribute_Single service.

DeviceNet Required		Assembly Object 0x04				
Object Implementation	Object Class	ID	Description	Get	Set	Value Limits
<input type="checkbox"/> None Supported	Attributes Open	1	Revision	<input checked="" type="checkbox"/>	<input type="checkbox"/>	
		2	Max instance	<input checked="" type="checkbox"/>	<input type="checkbox"/>	20 – 108
		DeviceNet Services		Parameter Options		
<input type="checkbox"/> None Supported	Services	<input type="checkbox"/>	Create			
		<input type="checkbox"/>	Delete			
		<input checked="" type="checkbox"/>	Get_Attribute_Single			
Object Instance		Instance Type		Instance Id(s)		
<i>The Object Instance section must be completed for each instance type implemented.</i>		Static Input		<input type="checkbox"/>		
		Static Output		<input checked="" type="checkbox"/> 20, 101, 102, 103, 104		
		ID	Description	Get	Set	Value Limits
<input type="checkbox"/> None Supported	Attributes Open	1	Number of members in list	<input type="checkbox"/>	<input type="checkbox"/>	
		2	Member list	<input type="checkbox"/>	<input type="checkbox"/>	
		3	Data	<input checked="" type="checkbox"/>	<input checked="" type="checkbox"/>	
		DeviceNet Services		Parameter Options		
<input type="checkbox"/> None Supported	Services	<input type="checkbox"/>	Delete			
		<input checked="" type="checkbox"/>	Get_Attribute_Single			
		<input checked="" type="checkbox"/>	Set_Attribute_Single			
		<input type="checkbox"/>	Get_Member			
		<input type="checkbox"/>	Insert_Member			
		<input type="checkbox"/>	Remove_Member			
Vendor Specific Additions		If yes, fill out the Vendor Specific Additions form.		Yes	<input type="checkbox"/>	
				No	<input checked="" type="checkbox"/>	



Get to indicate that attribute value is returned by the use of Get_Attribute_Single service.



Set to indicate that attribute value is written to by the use of Set_Attribute_Single service.

DeviceNet Required		Acknowledge Handler Object 0x2B				
Object Implementation	Object Class	ID	Description	Get	Set	Value Limits
	Attributes Open	1	Revision	<input checked="" type="checkbox"/>	<input type="checkbox"/>	
<input type="checkbox"/>	None Supported	2	Max instance	<input checked="" type="checkbox"/>	<input type="checkbox"/>	
		DeviceNet Services		Parameter Options		
	Services	<input type="checkbox"/>	Create			
		<input type="checkbox"/>	Delete			
<input type="checkbox"/>	None Supported	<input checked="" type="checkbox"/>	Get_Attribute_Single			
Object Instance		Section		Information		Max Instance ID
<i>The Object Instance section must be completed for each instance type implemented.</i>		Instance type		Static		<input checked="" type="checkbox"/>
				Dynamic		<input type="checkbox"/>
Object Implementation	Object Class	ID	Description	Get	Set	Value Limits
	Attributes Open	1	Acknowledge Timer	<input checked="" type="checkbox"/>	<input checked="" type="checkbox"/>	
		2	Retry Limit	<input checked="" type="checkbox"/>	<input checked="" type="checkbox"/>	
		3	COS Producing Conn. Inst.	<input checked="" type="checkbox"/>	<input checked="" type="checkbox"/>	
		4	Ack List Size	<input checked="" type="checkbox"/>	<input type="checkbox"/>	
		5	Ack List	<input checked="" type="checkbox"/>	<input type="checkbox"/>	
		6	Data with Ack Path List	<input checked="" type="checkbox"/>	<input type="checkbox"/>	
<input type="checkbox"/>	None Supported	7	Data with Ack Path List	<input checked="" type="checkbox"/>	<input type="checkbox"/>	
		DeviceNet Services		Parameter Options		
	Services	<input type="checkbox"/>	Delete			
		<input checked="" type="checkbox"/>	Get_Attribute_Single			
<input type="checkbox"/>	None Supported	<input checked="" type="checkbox"/>	Set_Attribute_Single			
		<input type="checkbox"/>	Add_Ack_Data_Path			
		<input type="checkbox"/>	Delete_Ack_Data_Path			
Vendor Specific Additions		If yes, fill out the Vendor Specific Additions form.		Yes	<input type="checkbox"/>	
				No	<input checked="" type="checkbox"/>	

Get to indicate that attribute value is returned by the use of Get_Attribute_Single service.

Set to indicate that attribute value is written to by the use of Set_Attribute_Single service.

DeviceNet Open Object Implementation	OBJECT NAME	AC/DC Motor Data		OBJECT ID 0 x 28		
	Object Class	ID	Description	Get	Set	Value Limits
	Attributes	1	Revision	<input checked="" type="checkbox"/>	<input type="checkbox"/>	
		2	Max instance	<input checked="" type="checkbox"/>	<input type="checkbox"/>	

	Code (Hex)	Service Description	Parameter Type/Options
Services	0x0E	Get_Attribute_Single	

Object Instance	ID	Description	Get	Set	Value Limits
Attributes	3	Motor Type	<input checked="" type="checkbox"/>	<input checked="" type="checkbox"/>	USINT 0 – 10
	6	Rated Current	<input checked="" type="checkbox"/>	<input checked="" type="checkbox"/>	UINT 0 – 65535
	7	Rated Voltage	<input checked="" type="checkbox"/>	<input checked="" type="checkbox"/>	UINT 0 – 2000
	8*	Rated Power	<input checked="" type="checkbox"/>	<input checked="" type="checkbox"/>	UDINT 0 – 5000000
	9*	Rated Frequency	<input checked="" type="checkbox"/>	<input checked="" type="checkbox"/>	UINT 0 – 300
	15*	Base Speed	<input checked="" type="checkbox"/>	<input checked="" type="checkbox"/>	UINT 0 – 18000

*Not supported by DC Drive

	Code (Hex)	Service Description	Parameter Options
Services	0x0E	Get_Attribute_Single	
	0x10	Set_Attribute_Single	

Vendor Specific Additions	If yes, fill out the Vendor Specific Additions form.	Yes	<input type="checkbox"/>
		No	<input checked="" type="checkbox"/>

Get to indicate that attribute value is returned by the use of Get_Attribute_Single service.
 Set to indicate that attribute value is written to by the use of Set_Attribute_Single service.

DeviceNet Open	OBJECT NAME	Control Supervisor		OBJECT ID 0 x 29		
	Object Class	ID	Description	Get	Set	Value Limits
Object Implementation	Attributes	1	Revision	<input checked="" type="checkbox"/>	<input type="checkbox"/>	
		2	Max instance	<input checked="" type="checkbox"/>	<input type="checkbox"/>	1

	Code (Hex)	Service Description	Parameter Type/Options
Services	0x0E	Get_Attribute_Single	

Object Instance	ID	Description	Get	Set	Value Limits
Attributes	3	Run1	<input checked="" type="checkbox"/>	<input checked="" type="checkbox"/>	BOOL 0, 1
	7	Running1	<input checked="" type="checkbox"/>	<input type="checkbox"/>	BOOL 0, 1
	10	Faulted	<input checked="" type="checkbox"/>	<input type="checkbox"/>	BOOL 0, 1
	12	Fault Rst	<input checked="" type="checkbox"/>	<input checked="" type="checkbox"/>	BOOL 0, 1

	Code (Hex)	Service Description	Parameter Options
Services	0x05	Reset	
	0x0E	Get_Attribute_Single	
	0x10	Set_Attribute_Single	

Vendor Specific Additions	If yes, fill out the Vendor Specific	Yes	<input type="checkbox"/>
	Additions form.	No	<input checked="" type="checkbox"/>

Get to indicate that attribute value is returned by the use of Get_Attribute_Single service.
 Set to indicate that attribute value is written to by the use of Set_Attribute_Single service.

DeviceNet Open Object Implementation	OBJECT NAME	AC/DC Drive		OBJECT ID 0 x 2A		
	Object Class	ID	Description	Get	Set	Value Limits
	Attributes	1	Revision	<input checked="" type="checkbox"/>	<input type="checkbox"/>	
		2	Max instance	<input checked="" type="checkbox"/>	<input type="checkbox"/>	

	Code (Hex)	Service Description	Parameter Type/Options
Services	0x0E	Get_Attribute_Single	

Object Instance	ID	Description	Get	Set	Value Limits
Attributes	4	Net Ref	<input checked="" type="checkbox"/>	<input checked="" type="checkbox"/>	BOOL 0, 1
	6	Drive Mode	<input checked="" type="checkbox"/>	<input checked="" type="checkbox"/>	USINT 0
	7	Speed Actual	<input checked="" type="checkbox"/>	<input type="checkbox"/>	INT
	8	Speed Ref	<input checked="" type="checkbox"/>	<input checked="" type="checkbox"/>	INT
	29	Ref From Net	<input checked="" type="checkbox"/>	<input type="checkbox"/>	BOOL 0, 1 0 = Local 1 = DeviceNet

	Code (Hex)	Service Description	Parameter Options
Services	0x0E	Get_Attribute_Single	
	0x10	Set_Attribute_Single	

Vendor Specific Additions	If yes, fill out the Vendor Specific Additions form.	Yes	<input type="checkbox"/>
		No	<input checked="" type="checkbox"/>

Get to indicate that attribute value is returned by the use of Get_Attribute_Single service.
 Set to indicate that attribute value is written to by the use of Set_Attribute_Single service.

- Extension to Open Object
- Vendor Specific Object

Vendor	OBJECT NAME	ABB Drives		OBJECT ID 0 x 64		
Specific	Object Class	ID	Description	Get	Set	Value Limits
Object Implementation	Attributes	1	Revision	<input checked="" type="checkbox"/>	<input type="checkbox"/>	
		2	Max instance	<input checked="" type="checkbox"/>	<input type="checkbox"/>	

	Code (Hex)	Service Description	Parameter Type/Options
Services	0x0E	Get_Attribute_Single	

Object Instance	ID	Description	Get	Set	Value Limits
Attributes	100	Aux_CW	<input checked="" type="checkbox"/>	<input checked="" type="checkbox"/>	UINT
	101	Aux_SW	<input checked="" type="checkbox"/>	<input type="checkbox"/>	UINT
	102	ABB_CW	<input checked="" type="checkbox"/>	<input checked="" type="checkbox"/>	UINT
	103	ABB_SW	<input checked="" type="checkbox"/>	<input type="checkbox"/>	UINT
	104	ABB_Ref1	<input checked="" type="checkbox"/>	<input checked="" type="checkbox"/>	INT
	105	ABB_ACT1	<input checked="" type="checkbox"/>	<input type="checkbox"/>	INT
	106	ABB_Ref2	<input checked="" type="checkbox"/>	<input checked="" type="checkbox"/>	INT
	107	ABB_ACT2	<input checked="" type="checkbox"/>	<input type="checkbox"/>	INT
	108	DSET3_1	<input checked="" type="checkbox"/>	<input checked="" type="checkbox"/>	INT
	109	DSET3_2	<input checked="" type="checkbox"/>	<input checked="" type="checkbox"/>	INT
	110	DSET3_3	<input checked="" type="checkbox"/>	<input checked="" type="checkbox"/>	INT
	111	DSET4_1	<input checked="" type="checkbox"/>	<input type="checkbox"/>	INT
	112	DSET4_2	<input checked="" type="checkbox"/>	<input type="checkbox"/>	INT
113	DSET4_3	<input checked="" type="checkbox"/>	<input type="checkbox"/>	INT	

	Code (Hex)	Service Description	Parameter Options
Services	0x0E	Get_Attribute_Single	
	0x10	Set_Attribute_Single	

- Get** to indicate that attribute value is returned by the use of Get_Attribute_Single service.
- Set** to indicate that attribute value is written to by the use of Set_Attribute_Single service.

- Extension to Open Object
- Vendor Specific Object

Vendor	OBJECT NAME	ABB Drives Parameters		OBJECT ID 0 x 65		
Specific	Object Class	ID	Description	Get	Set	Value Limits
Object	Attributes	1	Revision	<input checked="" type="checkbox"/>	<input type="checkbox"/>	
Implementation		2	Max instance	<input checked="" type="checkbox"/>	<input type="checkbox"/>	1 – 99 = Parameter Group > instance number

Services	Code (Hex)	Service Description	Parameter Type/Options
	0x0E	Get_Attribute_Single	

Object Instance	ID	Description	Get	Set	Value Limits
Attributes	101 – 199	Parameter within group	<input checked="" type="checkbox"/>	<input checked="" type="checkbox"/>	INT

Services	Code (Hex)	Service Description	Parameter Options
	0x0E	Get_Attribute_Single	
	0x10	Set_Attribute_Single	

- Get** to indicate that attribute value is returned by the use of Get_Attribute_Single service.
- Set** to indicate that attribute value is written to by the use of Set_Attribute_Single service.



ABB Industry Oy

Drives
P.O.Box 184
FIN-00381 Helsinki
FINLAND
Telephone: +358 10 222 000
Fax: +358 10 222 2681
Internet: www.abb.com

ABB Automation Inc.

Drives & Power Products
16250 West Glendale Drive
New Berlin, WI 53151
USA
Telephone: 262 785-8378
800 243-4384
Fax: 262 780-5135

NDNA-02/EN
3AFY 58919829 R0325 REV B
EFFECTIVE: 1.10.2001