



www.saftronics.com

DG2+ & DF8+
Isolation Module Kit
AA1174

Saftronics, Inc.

5580 Enterprise Pkwy., Ft. Myers, FL 33905

Telephone: (941) 693-7200

Fax: (941) 693-2431

www.saftronics.com

P/N 027-1174

REV 07/01

AA1174 ISOLATION MODULE KIT

DESCRIPTION

The AA1174 option modules provide an opto-isolated interface between the input auto & manual control signals and the DF8+ or DG2+ Single Phase DC Controller. The modules are offered in four separate kits (see Table 1).

KIT P/N	WIRING HARNESS	MOUNTING HARDWARE	NEMA AUTO/MAN SWITCH
FAA1174-DF8 C	X	X	
FAA1174-DF8 N	X	X	X
FAA1174-DG2 C	X w/Resistor	X	
FAA1174-DG2 N	X w/Resistor	X	X

TABLE 1

Using the AA1174 Isolation Module, the DF8+ and the DG2+ can operate in the auto mode from either a jumper selectable voltage, or 4-20mA signal source. In the case of the DG2+, a (+) 0-10VDC or 4-20mA input provides an isolated (+) 0-10VDC output. For the DF8+, a bipolar input of (+/-) 0-10VDC will result in an isolated (+/-) 0-10VDC output for bi-directional operation, as well as (+) 0-10VDC or 4-20mA for unidirectional applications. A contact controlled, on board relay, allows switching between manual and auto operation for both modes.

The modules require a regulated power supply of (\pm)12VDC or (\pm)15VDC with dropping resistor on the +15VDC input. This supply is usually available from the controller.

SPECIFICATIONS

Input Power - (\pm)12VDC or (\pm)15VDC with a 22W 1W dropping resistor on the +15VDC Input

Controller	Signal Input	Input Resistance	Isolated Output
DG2+	(+)0-10VDC	1M Ohm	(+)0-10VDC
	4-20mA	100 Ohm	(+)0-10VDC
DF8+	(+/-)0-10VDC	1M Ohm	(+/-)0-10VDC
	(+)0-10VDC	1M Ohm	(+)0-10VDC
	4-20mA	100 Ohm	(+)0-10VDC

TABLE 2

SPECIFICATIONS con't

Input/Output Isolation Voltage -	500VDC
Input/Output Isolation Resistance -	>10 ⁹ Ohms
Environmental -	(-)10 C - (+)50 C

INSTALLATION

Power down controller and proceed as follows. Referring to Fig. 1, 2 & 3, using the appropriate kit (see Table 1), install the AA1174 module using the provided hardware and wiring harness*. For the DG2+ C or N, the harness includes a 22 Ohm 1 Watt resistor (see Fig. 2). Place jumper J2 on the AA1174 in the proper position, pins 1 & 2 for input voltage operation or pins 2 & 3 for 4-20mA. In NEMA 4 kits (DF8+N & DG2+N), a manual/auto switch is included and may be mounted through the front cover and wired accordingly.

***Note - When installing the harness on the DF8+ (Fig. 1), the wire from terminal 2 on the AA1174 must be soldered to the left most PIN of the VR3 regulator. Use extreme caution not to damage any components and use the appropriate soldering temp.**

Complete input wiring, see Fig. 3, in accordance with the application requirements. All signal wiring should be 2 conductor shielded and run separately from all power and AC control wiring. Insure the completed assembly meets all electrical codes and regulations.

Power up controller and check for proper operation.

IMPORTANT!

- i – The GND reference on J1 terminal block is electrically isolated from IGND on J3 terminal block.**
- ii - The AA1174 is factory calibrated and should not require field adjustment – if special calibration is required or the module is not functioning properly, proceed as follows.**

A1174 SET-UP AND CALIBRATION

The following equipment is required:

Digital voltmeter

(+) 0-10VDC or (+/-) 0-10VDC signal source

4-20mA source

SET-UP FOR VOLTAGE SOURCE

- 1) With the AA1174 installed on the controller and with the controller powered down jumper J1-1 to J1-3 and J1-9 to J1-20, place the factory provided jumper between pins 1 & 2 (voltage) of J2.
- 2) Apply power to the drive (with motor disconnected) and adjust RV1 (offset) (see Fig. 1 or 2) so that the voltage between J3-1 (Vout) and J3-3 (IGND) reads 0 Volts DC.
- 3) Jumper J1-5 to J1-6 for auto mode (Vout should still read 0 Volts DC $\pm 0.25V$). Remove the jumpers from J1-1 to J1-3 and J1-9 to J1-20.
- 4) Connect voltage source (+) 0-10VDC or (+/-) 0-10VDC to J1-20 (auto Vin) and J1-9 (GND). Adjust the input to full scale, +10VDC and adjust RV2 (gain) so that the output voltage J3-1 (Vout) to J3-3 (IGND) reads +10VDC.

Note: The RV2 gain adjustment will allow a range of 0.9 to 1.9 of the input, i.e. $V_{out} = 0.9-1.9 \times \text{Auto } V_{in}$ for scaling.

SET-UP FOR 4-20mA SOURCE

- 1) With power off, jumper J1-5 to J1-6 (auto/man) and place the factory provided jumper between pins 2 & 3 of J2.
- 2) Connect a 4-20mA source between J1-14 (auto 4-20mA) and J1-7 (GND). With power applied to the controller and with 4mA input, adjust RV1 (offset), so that the voltage between J3-1 (Vout) and J3-3 (IGND) reads 0 VDC.
- 3) Next apply 20mA and with RV2 (gain) adjust voltage out J3-1 (Vout) to J3-3 (IGND) to read +10VDC.

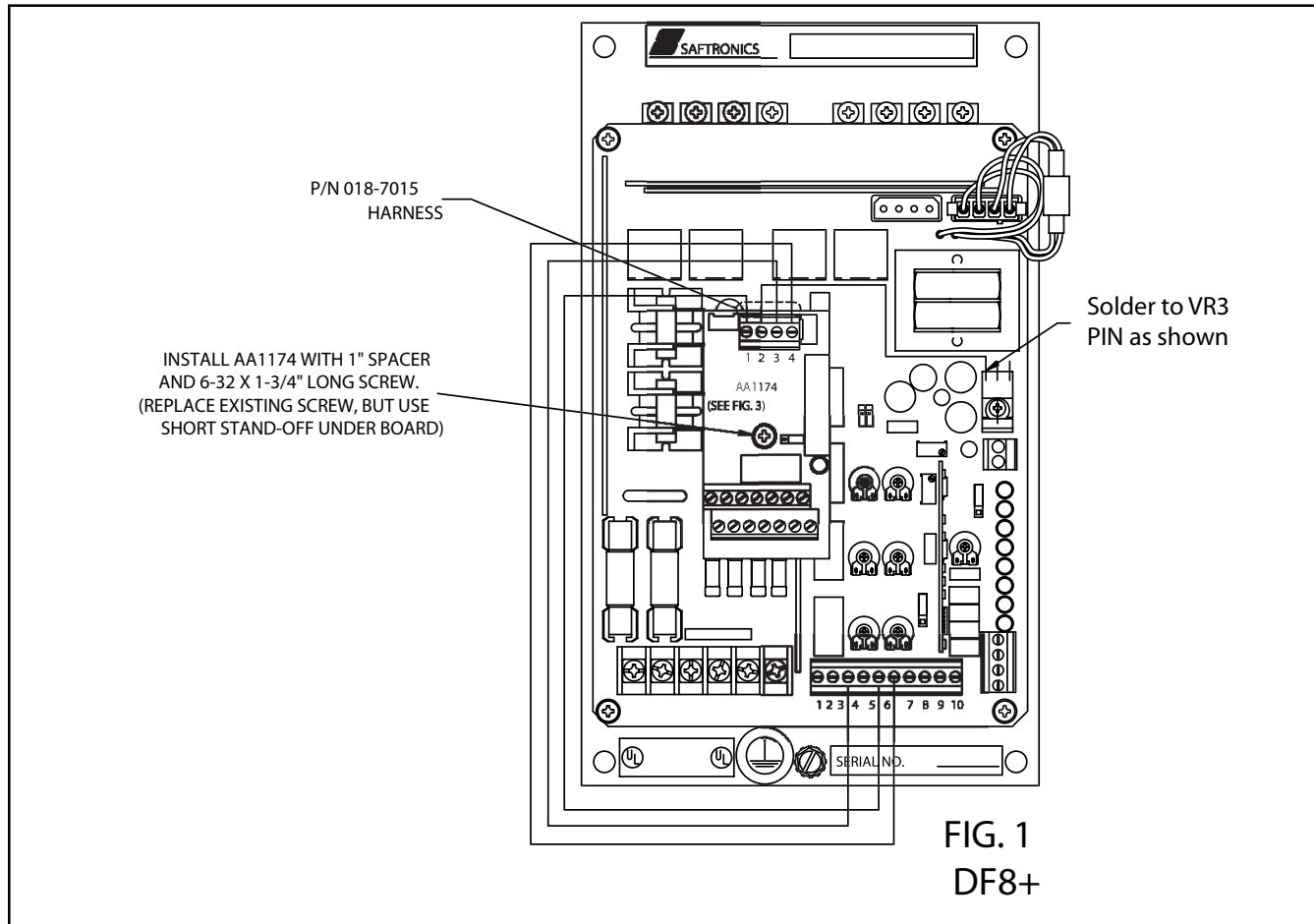

FIG. 1
DF8+

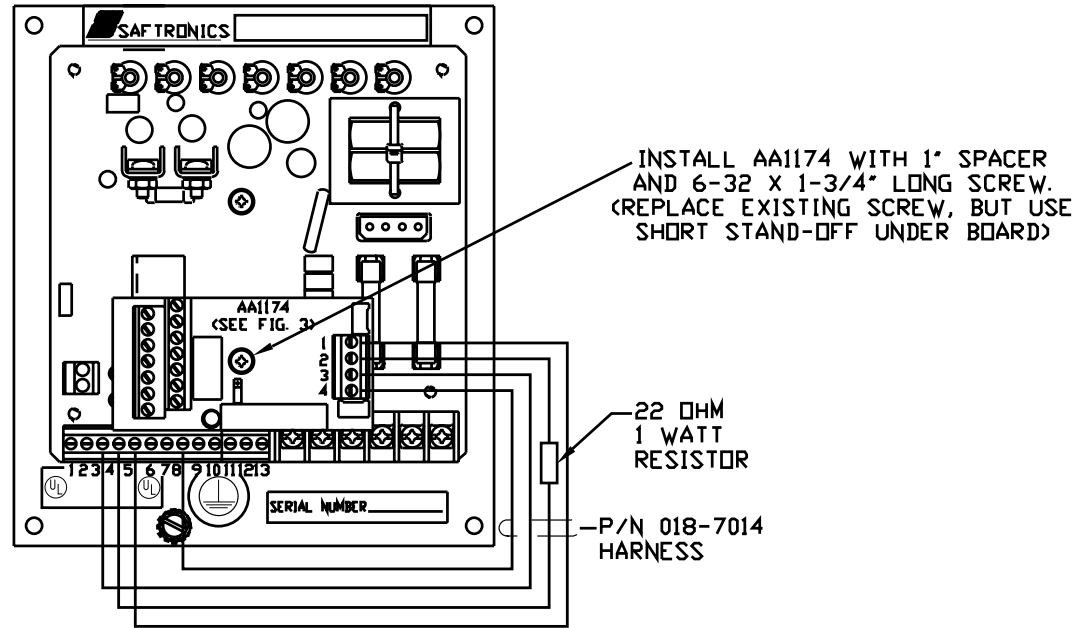
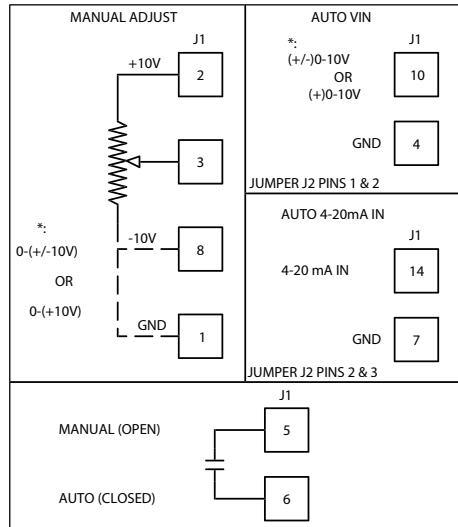

FIG. 2
DG2+



*=DF8+ ONLY

J1 CONNECTIONS

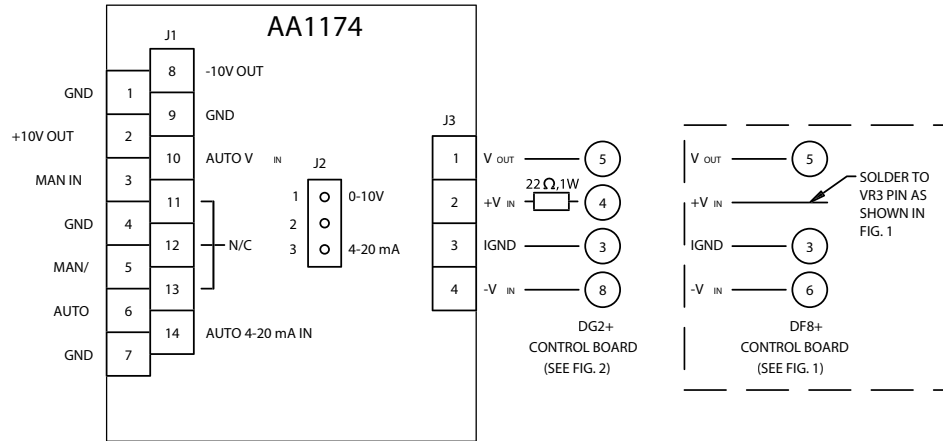

FIG. 3