

## 1/6 through 5 HP Adjustable Speed, DC Motor Controllers

- 1/6 - 5 HP
- 115 or 230 V, Single Phase
  - Reconnectable
- Four Quadrant Regenerative
- Selectable Deadband
- AC Line Starting
- DC Tachometer Feedback
- Run Contact
- Configurations
  - Open Chassis
  - "Bookcase" Style
  - NEMA 4/12
- NEC & NEMA Compliance
- UL & cUL Listed

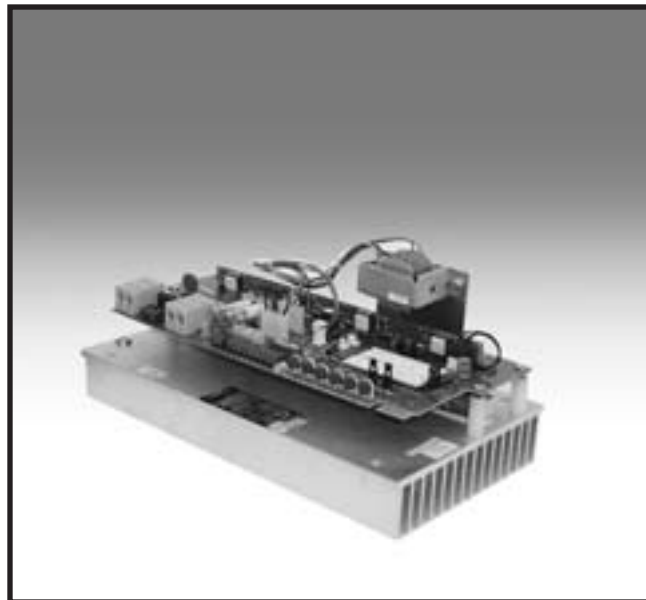

FIGURE 1. Series 2240 Controller

Series 2240 units are offered in a variety of standard models based on the three functional groups as shown in Tables 1-3. These units differ from the 2230 series in that they expand horsepower range with capacities up to 5 HP while offering adequate space to facilitate mounting a wide range of optional features. Model numbers that include a "P" suffix identify enclosed units assembled by adding a top cover

assembly to a basic chassis unit. Top cover assemblies P1, P2 and P3 include integral operator controls. Top cover control P0 does not and is therefore intended for remote control operation. The top cover assemblies may be factory installed or, if desired, easily added to the basic chassis models as field-installed kits. All models are reconnectable for either a 115V or 230V AC power source.

TABLE 1. MODEL TYPES

TABLE 1: SERIES 2240 NEMA 4/12 ENCLOSED UNITS WITH INTEGRAL OPERATOR CONTROLS

| HORSEPOWER RANGE (1) |       | MODEL NUMBER | FUNCTION   |
|----------------------|-------|--------------|--|
| 115V                 | 230V  |              |  |
| 1/6-1                | 1/2-5 | 2242P1 (2)   | Run, Stop, Jog                                     |
| 1/6-1                | 1/2-5 | 2242BP1 (2)  | Run, Stop, Jog<br>Armature Contactor<br>Run and DB |

TABLE 2: SERIES 2240 NEMA 4/12 ENCLOSED UNITS WITHOUT OPERATOR CONTROLS

| HORSEPOWER RANGE (1) |       | MODEL NUMBER | FUNCTION                                       |
|----------------------|-------|--------------|--|
| 115V                 | 230V  |              |  |
| 1/6-1                | 1/2-5 | 2242P0 (2)   | Run-Stop                                       |
| 1/6-1                | 1/2-5 | 2242BP0 (2)  | Run, Stop,<br>Armature Contactor<br>Run and DB |

TABLE 3: SERIES 2240 BASIC CHASSIS UNITS WITHOUT OPERATOR CONTROLS

| HORSEPOWER RANGE (1) |       | MODEL NUMBER | FUNCTION                                       |
|----------------------|-------|--------------|--|
| 115V                 | 230V  |              |  |
| 1/6-1                | 1/2-5 | 2242         | Run-Stop                                       |
| 1/6-1                | 1/2-5 | 2242B        | Run, Stop,<br>Armature Contactor<br>Run and DB |

NOTES: (1) Units are shipped calibrated for the maximum horsepower rating. Units may be calibrated for other standard ratings by the removal of jumpers in accordance with instructions provided. Standard ratings are:  
All 2240 models are also rated 5 HP at 230V.  
Units are shipped connected for 230V.  
Units may be easily reconnected for 115V.  
All units are bidirectional  
(2) Includes option 1170A, Cooling Fan, as standard.

# 2240



## REGENERATIVE SINGLE-PHASE DC SERIES

### PRINCIPLES OF OPERATION

Regenerative adjustable speed drives also known as four-quadrant drives, are capable of controlling not only the speed and direction of motor rotation, but also the direction of motor torque. This is illustrated by Figure 2.

The term regenerative describes the ability of the drive under braking conditions to convert the mechanical energy of the motor and connected load into electrical energy which is returned (or regenerated) to the AC power source.

When the drive is operating in Quadrants I and III, both motor rotation and torque are in the same direction and it functions as a conventional nonregenerative unit. The unique characteristics of a regenerative drive are apparent in Quadrants II and IV. In these quadrants, the motor torque opposes the direction of motor rotation which provides a controlled braking or retarding force. A high performance regenerative drive, such as the Series 2230/2240, is able to switch rapidly from motoring to braking modes while simultaneously controlling the direction of motor rotation.

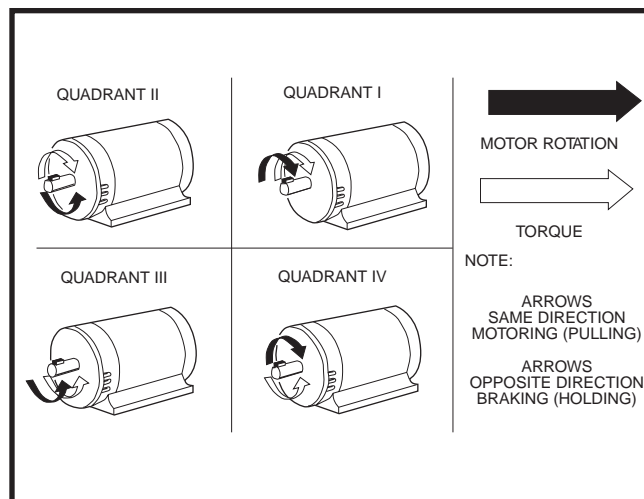

FIGURE 2. Four-Quadrant Drives

### DESIGN FEATURES AND FUNCTIONS

- Construction** — The die-cast aluminum alloy base assembly forms the basic Series 2240 open chassis which includes regulator electronics, AC line fuse, power conversion and protective circuitry as a totally functional, self contained unit. The entire back surface of the Model 2242 base is a unique, pin configuration heatsink with omni-directional heat dissipation characteristics. This allows vertical or horizontal wall mounting as best suits the available space. All open models are cooled by natural convection. Conduit entry is provided in the base by two 3/4-14 NPT tapped holes, one each on the top and bottom.

Enclosed models consist of the basic chassis with the addition of a screw fixed cover which is gasketed with an oil resistant synthetic rubber gasket to exclude contaminants. Basic enclosed units are TENV, NEMA 4 and 12. All models with integral operator controls also include flexible boots to seal the operator control switches and a seal for the motor speed potentiometer.

*Model 2242, when rated five horsepower as an enclosed unit, requires the addition of Option 1170A cooling fan assembly. This is included when an enclosed controller is ordered.*

Series 2240 unit covers are molded of high strength Noryl® engineering plastic. An aperture in the cover permits mounting a blank panel for remote control models or various standard or optional local operator control panels. *Where a hinged cover is desired, Option 1638 provides a kit permitting easy field installation.*

- Full-Wave Power Conversion** — Dual full-wave converter configuration, consists of eight SCRs connected in back to back bridges of four SCRs each. The SCR's are rated 600 PIV minimum.

## DESIGN FEATURES AND FUNCTIONS (Continued)

3. **Voltage Transient Protection** — Metal oxide suppressor with RC snubbers across the AC line input and a second RC snubber across the DC output.
4. **AC Line Protection** — A 100,000 ampere interrupting capacity AC line fuse provides instantaneous protection from peak loads and fault currents. This line fuse is located inside the controller. A molded-case magnetic-trip circuit breaker (Option 1010) is available for Model 2242 Controllers, which provides a manual disconnection to the controller, and also provides automatic instantaneous trip protection from a peak load.
5. **AC Line Power** — Controllers are reconnectable for 115 or 230 VAC, single-phase, 50 or 60 Hertz.
6. **Safety Features** — UL listed and cUL (Canadian UL). Requires mandatory restart after power interruption.
7. **AC Line Starting** — Provision is included to defeat the mandatory restart after power interruption to permit run-stop control of the units by external AC line contactor.
8. **Deadband Selection** — This will help to eliminate “creeping” motor speed with zero speed reference signal. It gives a non-adjustable  $\pm 2\%$  deadband around zero speed.
9. **Field Supply** — Transient protected, full-wave and half-wave field supply.
10. **Operator Controls** — Units with a “P1” suffix in the catalog number contain a motor speed potentiometer and a Run-Stop-Jog switch. The speed potentiometer is reconnectable for unidirectional or bidirectional operation.
11. **Static Reversing** — Solid state, electronic reversal of the motor armature. No reversing contacts to burn, arc or wear.
12. **Static Braking** — Provides smooth regeneration braking of the DC drive motor. Braking is effective whenever the manual speed control potentiometer is reset to command a reduction in speed or change in the direction of motor rotation.
13. **DC Tachometer Feedback** — Unit includes terminals to accept a 5.5 to 100VDC/1000 RPM (1750 RPM maximum) signal from a motor mounted DC tachometer generator for improved speed regulation.
14. **External Current (Torque) Control** — Terminals are provided for external forward and reverse current limit (torque) control.
15. **Diagnostic LED**— A dual color LED, green for power on, red for current limit is provided.
16. **Customer Use Run Contacts** — Form A normally open contact rated five amps at 115 VAC or 30 VDC coordinated with run command may be used for external control and indicating devices. May be applied as pushbutton seal-in or a drive “run” contact.
17. **Hybrid Circuitry** — Miniature components in a custom surface mount assembly, improve reliability and make possible more features in the smallest possible mechanical configuration.
18. **Option Connectors** — These connectors are provided for options that fit in a space provided inside the controller.
19. **Dynamic Braking** — Standard feature of model numbers with a “B” suffix. Dynamic braking provides exponential rate braking of the DC motor armature. Included is a DB resistor with an anti-plug circuit to prevent restarting the controller until the braking cycle is complete, thereby preventing a potentially damaging contact arcing. The DB resistor is rated for stopping a typical load, when the external machine inertia does not exceed that of the motor armature, as shown in Table 5.
20. **Control Voltage** — A transformer coupled 24 VDC power supply provides non-isolated control power for all magnetic control logic and operator controls.
21. **DIP Switch Settings** — An 8-position DIP Switch is used to program the controller for various applications and operations.
22. **Motor Contactor** — Controller model numbers with a ‘B’ suffix, e.g., 2231B, 2242BPO, have a DC magnetic armature contactor, which disconnects both motor armature leads from the controller. An antiplug circuit ensures that the contactor does not make or break DC from the SCR bridge.



FIGURE 4. Series 2240 Controller

# 2240



## REGENERATIVE SINGLE-PHASE DC SERIES

### RATINGS AND CHARACTERISTICS

#### OPERATING CONDITIONS

1. **Line Voltage Variation**..... ±10% of rated
2. **Line Frequency Variation**..... ± 2 Hz
3. **Ambient Temperature (1)**.....0°C to 40°C  
(32°F to 104°F)
4. **Altitude (Standard)**.....1000 meters  
(3300 feet) Maximum
5. **Relative Humidity** .....95% Noncondensing

Notes: (1) 0°C to 55°C (32°F to 131°F) maximum in enclosed ..... areas where chassis models are mounted.

#### RATINGS

1. **Horsepower Range** .....1/6 to 5 HP
2. **Power Source** .....115 or 230 VAC  
Single-Phase, 50 or 60 Hz
3. **Operating Voltages** .....(See Table 3)
4. **Service Factor**.....1.0
5. **Duty** .....Continuous
6. **Overload Capacity (Armature Circuit)**.....150% for 1 Minute
7. **Line Fuse Interrupting Capacity** .....100,000 Amps.
8. **Reference Power Supply (Non-Isolated)**..... ±10VDC
9. **Run Speed Potentiometer** .....10K ohms, 1/2W
10. **Current/Torque Reference Potentiometer**.....10K ohms, 1/2W

TABLE 2. COVER ASSEMBLIES WITH LOCAL OPERATOR CONTROLS

| Cover Model Number | Control Elements      |                 |
|--------------------|-----------------------|-----------------|
|                    | Toggle Switches       | Potentiometer   |
| P0                 | None                  | None            |
| P1                 | Run-Stop-Jog (1), (2) | Motor Speed (3) |

- Notes: (1) Maintained in Run and Stop positions  
 (2) Jog Speed is set by the Run Speed Potentiometer  
 (3) Motor Speed Potentiometer is 100-0-100% (Reconnectable for 0-100%)

#### ADJUSTMENTS

Potentiometer adjustments are provided for:

1. **Current Limit** .....10 to 150% Full-Load Torque  
(Independent forward and reverse circuits)
2. **Maximum Speed** .....50 to 100% of Motor Base Speed
3. **IR (Load) Compensation** .....10% Boost
4. **Acceleration** .....0.2 to 30 Seconds
5. **Deceleration** .....0.2 to 30 Seconds
6. **Deadband (Yes or No Adjustment)**.....0 or ±2%
7. **Jog Speed** .....0 to 100% of Motor Base Speed

#### PERFORMANCE CHARACTERISTICS

1. **Controlled Speed Range** — Zero to motor base speed. Speed range with respect to specified regulation is listed in Table 4. See Catalog Section E for continuous duty application limitations of DC motors.
2. **Speed Regulation** — Regulation percentages shown in Table 4 are of motor base speed under steady-state conditions.
3. **Efficiency** — (Rated Speed / Rated Load)
  - (a) Controller SCR regulator .....98%
  - (b) Complete drive with motor (typical).....85%
4. **Current Ripple Frequency** .....120 Hz (60 Hz line)  
100 Hz (50 Hz line)
5. **Controller Bandwidth (Responsiveness)** .....5 Hz

TABLE 3. OPERATING VOLTAGES

| Power Source (Single-Phase) | Output VDC |         | Control Reference Voltage | Magnetic Control Voltage |
|-----------------------------|------------|---------|---------------------------|--------------------------|
|                             | Armature   | Field   |                           |                          |
| 115V, 50 or 60 Hz           | 0-90       | 50/100  | 0 to ±10 VDC              | 24 VDC                   |
| 230V, 50 or 60 Hz           | 0-180      | 100/200 |                           |                          |

TABLE 4. SPEED REGULATION CHARACTERISTICS

| Regulation Method                              | Variable        |                   |                           |                   | Speed Range |
|--|-----------------|-------------------|---------------------------|-------------------|-------------|
|  | Load Change 95% | Line Voltage ±10% | Field Heating Cold/Normal | Temperature ±10°C |             |
| Standard Voltage Feedback with IR Compensation | 2%              | ±1%               | 5-12%                     | ±2%               | 50:1        |
| Tachometer Feedback with 5 PY DC Tach          | 0.5%            | ±1%               | 0.2%                      | ±2%               | 200:1       |



## REGENERATIVE SINGLE-PHASE DC SERIES

### RATINGS & CHARACTERISTICS (Continued)

**TABLE 5. DYNAMIC BRAKING CHARACTERISTICS (1) (2)**

| Component          | Model | Rated Voltage | Rated Horsepower |     |     |     |     |     |     |     |     |     |
|--------------------|-------|---------------|------------------|-----|-----|-----|-----|-----|-----|-----|-----|-----|
|                    |       |               | 1/6              | 1/4 | 1/3 | 1/2 | 3/4 | 1   | 1½  | 2   | 3   | 5   |
| Braking Torque (%) | 2231  | 115V          | 180              | 129 | 103 | 66  | 44  | 34  | N/A | N/A | N/A | N/A |
|                    |       | 230V          | N/A              | N/A | N/A | 278 | 200 | 138 | 93  | 66  | N/A | N/A |
|                    | 2232  | 115V          | 300              | 214 | 171 | 111 | 74  | 57  | N/A | N/A | N/A | N/A |
|                    |       | 230V          | N/A              | N/A | N/A | 462 | 316 | 218 | 146 | 103 | 79  | N/A |
|                    | 2242  | 115V          | 600              | 429 | 343 | 222 | 148 | 114 | N/A | N/A | N/A | N/A |
|                    |       | 230V          | N/A              | N/A | N/A | 923 | 632 | 436 | 293 | 207 | 159 | 96  |
| Stops Per Minute   | 2231  | 115V          | 15               | 12  | 11  | 8   | 6   | 2   | N/A | N/A | N/A | N/A |
|                    |       | 230V          | N/A              | N/A | N/A | 8   | 6   | 1   | 1   | 1   | N/A | N/A |
|                    | 2232  | 115V          | 9                | 6   | 5   | 5   | 4   | 4   | N/A | N/A | N/A | N/A |
|                    |       | 230V          | N/A              | N/A | N/A | 5   | 4   | 4   | 3   | 3   | 2   | N/A |
|                    | 2242  | 115V          | 15               | 12  | 10  | 10  | 7   | 7   | N/A | N/A | N/A | N/A |
|                    |       | 230V          | N/A              | N/A | N/A | 10  | 7   | 7   | 5   | 5   | 3   | 2   |

NOTE: (1) Ratings shown for units with contactor board.  
 (2) High inertia loads may extend braking time and cause the wattage rating of the dynamic braking resistors to be exceeded.

**TABLE 6. CONTROLLER WEIGHTS**

| Unit               | Weight lbs. (kgs.) |
|--------------------|--------------------|
| 2242               | 8.20 (3.72)        |
| 2242B              | 8.90 (4.04)        |
| 2242P0<br>2242P1   | 12.50 (5.67)       |
| 2242BP0<br>2242BP1 | 13.20 (5.99)       |

**TABLE 7. TYPICAL APPLICATION DATA**

| Component   |                     | Ratings       |       |       |       |       |       |       |       |       |       |      |
|---|---------------------|---------------|-------|-------|-------|-------|-------|-------|-------|-------|-------|------|
| Rated Horsepower (HP)                                     |                     | 1/6           | 1/4   | 1/3   | 1/2   | 3/4   | 1     | 1-1/2 | 2     | 3     | 5     |      |
| Rated Kilowatts (kW)                                      |                     | 0.124         | 0.187 | 0.249 | 0.373 | 0.560 | 0.746 | 1.120 | 1.492 | 2.238 | 3.730 |      |
| 1-Phase AC Input (Full-Load)                              | Line Amps           | 115V Unit     | 3.9   | 5.0   | 6.0   | 8.7   | 12.4  | 15.8  | -     | -     | -     | -    |
|   |                     | 230V Unit     | -     | -     | -     | 4.2   | 5.9   | 8.8   | 12.6  | 15.8  | 22.0  | 32.0 |
|   | KVA                 |               | 0.48  | 0.58  | 0.71  | 1.00  | 1.40  | 2.00  | 3.00  | 4.00  | 5.00  | 8.0  |
| DC Output (Full-Load)                                     | Motor Armature Amps | 90V           | 2.0   | 2.8   | 3.5   | 5.4   | 8.1   | 10.5  | -     | -     | -     | -    |
|   |                     | 180V          | -     | -     | -     | 2.6   | 3.8   | 5.5   | 8.2   | 11.6  | 15.1  | 25.0 |
|   | Motor Field Amps    | 2231/<br>2232 | 1.0   | 1.0   | 1.0   | 1.0   | 1.0   | 1.0   | 1.0   | 1.0   | 1.0   | -    |
|   |                     | 2242          | 2.0   | 2.0   | 2.0   | 2.0   | 2.0   | 2.0   | 2.0   | 2.0   | 2.0   | 2.0  |
| Full Load Torque (lb-ft) with 1750 RPM base Speed Motors  |                     | 0.5           | 0.75  | 1.0   | 1.5   | 2.2   | 3.0   | 4.5   | 6.0   | 9.0   | 15.0  |      |
| Minimum Transformer KVA for Voltage Matching or Isolation |                     | 0.5           | 0.75  | 0.75  | 1.0   | 1.5   | 2.0   | 3.0   | 5.0   | 7.5   | 10.0  |      |

# 2240



## REGENERATIVE SINGLE-PHASE DC SERIES

### DIMENSIONS

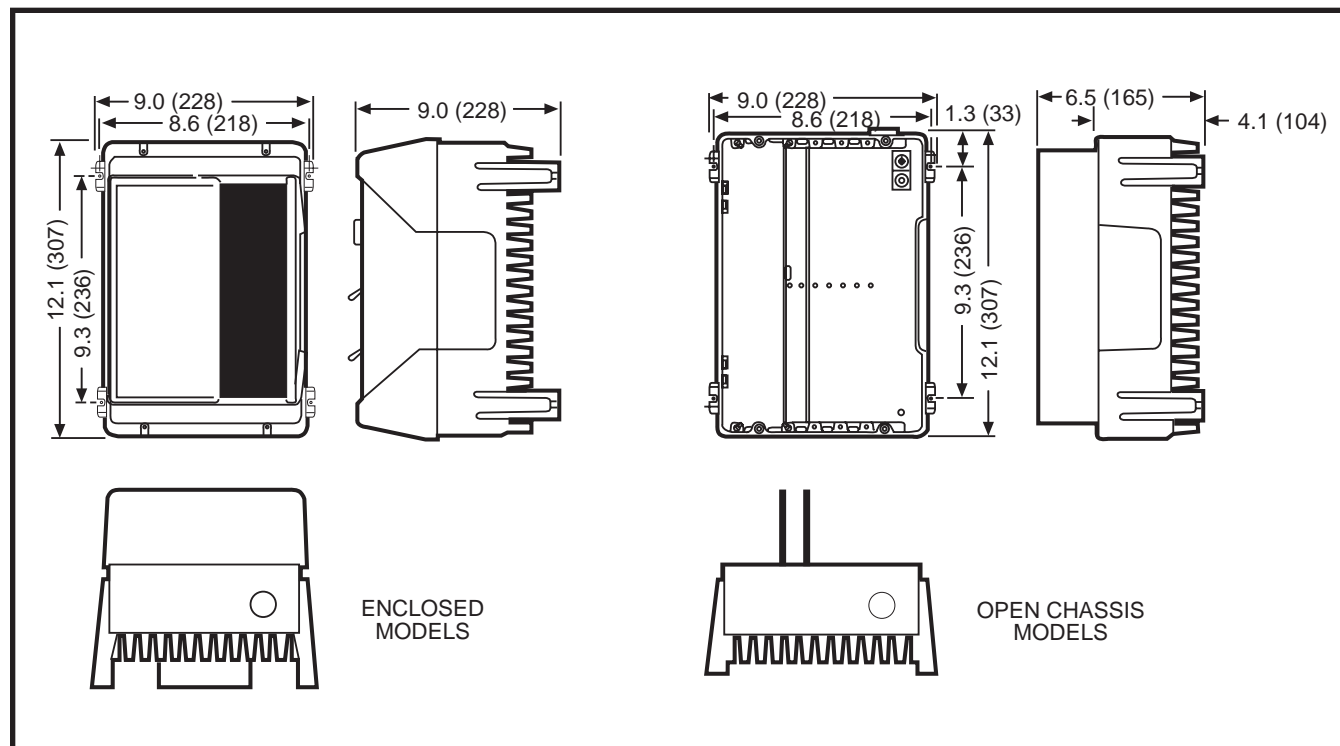

FIGURE 9. Series 2240 dimensions

### OPTIONS

The versatility of Series 2240 controllers for various applications can be extended by selecting one or more of the listed options. Most can be easily added in the field via simplified instructions provided. Table 8 lists the options in functional groups along with information on allowable combinations and installation complexity.

TABLE 8. ALLOWABLE OPTION COMBINATIONS

| Remarks   | Option Group | Option Number | Option Code           | Option   |
|---|--------------|---------------|-----------------------|--|
| <b>Enclosure Options</b> — Choice of any or all within this group. May be combined with options from any other group.   | A            | 1170A         | XK                    | Fan Assembly (5 HP Units Only)<br>(Required When Enclosed Model 2242 is Operated at 5 HP Rating) |
|   | A            | 1638          | XK                    | Hinge kit to allow the cover to swing open   |
| <b>Options Used To Convert Open Chassis Units into Units Into Enclosed Package Controllers</b> — Choice of one within this group. May be combined with options from any other groups. | B            | 1639          | XK                    | Cover Assembly, Blank Type P0  |
|   | B            | 1639C         | XK                    | Cover Assembly, Type P1  |
| <b>Power Options</b>  | C            | 1001          | XK                    | Armature Contactor With Dynamic Braking (May be Combined With All Options In This Group)         |
|   | C            | 1010          | XK                    | Circuit Breaker — Two Pole   |
| <b>Input Signal Options</b> — Choice of one within this group.  | D            | 1036          | XK, P                 | Four-Quadrant Acceleration/Deceleration  |
|   | D            | 1048          | XK                    | Limit Switch Reversing   |
|   | D            | 1052          | XK                    | Isolated Input   |
| <b>Feedback Options</b> — Choice of one within this group.  | E            | 1190          | XK                    | Torque Taper   |
|   | E            | 1670          | XK                    | Pulse Tachometer Feedback/Follower   |
| <b>External Options</b> — Choice of any or all within this group.   | G            | 1120          | K                     | Operator Control Station — Remote  |
|   | G            | 1120A         | K                     | Motor Speed Potentiometer, Ten-Turn With Analog Dial   |
|   | G            | 1120B         | K                     | Motor Speed Potentiometer, One-Turn  |
|   | G            | 1120C         | K                     | Motor Speed Potentiometer, Ten-Turn With Digital Dial  |
|   | G            | 1166          | K                     | Extra Equipment Manuals  |
| G   | 1611         | K             | Option Guide Card Kit |  |

XK—Factory or Field Kit, K—Field Kit, P—Plug-In Option

## OPTION DESCRIPTIONS

| Option Number | Description   |
|---------------|---|
| 1001          | <b>Motor Contactor with Dynamic Braking</b> —<br>The basic series 2240 controller is designed for bidirectional operation without an armature contactor. This option provides a two pole armature contactor which is necessary whenever the application requires a positive disconnection of the rectified armature source from the motor on a stop command. This option also includes a dynamic braking resistor which provides exponential rate braking of the DC motor armature and an anti-plug circuit to prevent restarting the controller until the braking cycle is complete. The dynamic braking resistor is rated for stopping a typical load, when the external machine inertia does not exceed that of the motor armature, as shown in Table 5. |
| 1010          | <b>AC Line Circuit Breaker, Two Pole</b> —<br>Provides a two-pole, magnetic only, fast trip circuit breaker as a means of manually disconnecting the Model 2242 controller from the AC line. The high interrupting capacity fuse in the basic unit is retained as primary short circuit protection.   |
| 1036          | <b>Four-Quadrant Acceleration/Deceleration</b> —<br>This option board has four adjustment potentiometers consisting of a forward acceleration potentiometer, a forward deceleration potentiometer, a reverse acceleration potentiometer and a reverse deceleration potentiometer. The potentiometers have an adjustment range of .3 to 30 seconds. Also, the board has a bypass mode to disable the four potentiometers on the option board and switch to the two potentiometers (acceleration and deceleration) on the control board.<br>This option board mounts on the control board and does not take up the option slot in the casting base.   |
| 1048          | <b>Limit Switch Reversing</b> —<br>This option board allows interfacing the controller with a variety of external devices, such as limit switches, push buttons and potentiometers. There are two speed potentiometers on this board, one for forward speed and one for reverse speed. These internal potentiometers can be switched out if external potentiometers are required. In addition, this board will allow a controlled stop feature with an adjustable speed dropout.  |
| 1052          | <b>Isolated Input and Follower</b> —<br>This option board isolates the motor speed potentiometer from the non-isolated controller for operator and equipment safety. Also, it will allow the controller to follow a 4-20 DCMA current signal and a wide range of DC voltage signals ( $\pm 0.5$ to $\pm 500$ VDC). This makes the option ideal for following signal transducers, motor shunts, DC tachometer generators and the armature voltage from DC motors.  |
| 1120          | <b>Control Station</b> —<br>Provides a standard remote control station for separate mounting by the user. Control elements are provided mounted within the station and wired to a terminal board.   |
| 1120A         | <b>Potentiometer, Ten-Turn Motor Speed (Analog Dial)</b> —<br>Provides a ten-turn, 2W potentiometer, knob and analog counting dial for separate mounting by user.   |
| 1120B         | <b>Potentiometer, Single-Turn Motor Speed Assembly</b> —<br>Provides a single-turn, 2W potentiometer, knob and dial wired to a terminal board for separate mounting by user.  |
| 1120C         | <b>Potentiometer, Ten-Turn Motor Speed (Digital Dial)</b> —<br>Provides a ten-turn, 2W potentiometer, with digital counting indicator dial assembly for separate mounting by user.  |
| 1170A         | <b>Fan Assembly</b> —<br>All 2242 enclosed models (used for 5 HP) require this fan assembly when operated at the five horsepower rating in a 40°C environment. Option includes a special base assembly/air baffle with a 24 VDC fan powered by a power supply within the Model 2242. This option may also be used for ratings less than five horsepower when open chassis models must operate in environments greater than 55°C, and enclosed models above 40°C.  |
| 1190          | <b>Torque Taper</b> —This option consists of a plug-in circuit board. This board provides an inverse-linear speed-torque relationship when operating in the braking (regenerative) mode, and provides constant torque in the motoring mode of operation. Motoring torque and braking torque are individually adjustable as well as forward and reverse torque taper.<br>Applications include the following:<br>1. Winders where the material being wound travels at a constant speed during winder roll buildup.<br>2. Unwinders, since this option provides relatively constant holdback tension ( $\pm 20\%$ ) from full roll to empty roll.  |
| 1611          | <b>Option Card Guide Kit</b> —<br>This option is required when mounting the option cards in the 2242 enclosure or if the option cards are mounted external.   |
| 1638          | <b>Hinge Kit, Enclosure Cover</b> —<br>Model 2242 enclosed controllers include a screw fixed, gasket cover which is removable for increased accessibility during installation, troubleshooting or repair. When desired the cover may also be provided with optional hinges making servicing more convenient. This option may be provided factory installed or a kit is offered for simple field installation.   |
| 1639          | <b>Cover Kit, Blank Type "P0"</b> —<br>Provides an enclosed blank (no operator devices) cover for field conversion of open chassis models into an enclosed unit for remote control.   |
| 1639C         | <b>Cover Kit, Type "P1" (Run-Stop-Jog)</b> —<br>Provides an enclosed (run-stop-jog switch with motor speed potentiometer) cover for field conversion of open chassis models into an enclosed unit for local control.  |
| 1670          | <b>Pulse Tachometer Feedback/Follower</b> —<br>This option interfaces the controller to a pulse train for speed reference or as a feedback signal. It allows the use of a 60 tooth gear for either speed reference or feedback. It is capable of providing digital pulse tach reference and/or feedback functions. The sensor can be a magnetic pickup (2 wire), proximity sensor (3 wire), AC tachometer generator (18 cycles/revolution), two-phase AC tachometer generator, or digital tachometer generator or encoder (240 pulses/revolution). Note: two phase AC tachometer generator can be used for follower or feedback applications, but not both.   |